

(19) Japan Patent Office (JP)

(12) PATENT APPLICATION PUBLICATION (A)

(11) Patent Application Publication No. H10-324191

(43) Publication Date December 8, 1998 (Heisei 10)

(51) Int. Cl.⁶ Ident. Code
B 60 Q 1/076

FI
B 60 Q 1/06 D

Examination Request: Not Made

Total No. of Claims: 4 FD (Total 8 pages)

(21) Application No. H9-151649

(22) Date of Filing May 26, 1997 (Heisei 9)

(71) Applicant 000002082
Suzuki Motor Corporation
300 Takatsuka-cho
Hamamatsu-shi, Shizuoka-ken
Japan

(72) Inventor KATO, Masahiro
c/o Suzuki Motor Corporation
300 Takatsuka-cho
Hamamatsu-shi, Shizuoka-ken

(74) Agent TAKAHASHI, Isamu
Patent Attorney

(54) Title of Invention
HEADLIGHT OPTICAL AXIS CONTROL DEVICE FOR MOTORCYCLE

(57) [ABSTRACT]

[Problem] To stably ensure a beam irradiation range of the headlight even when the pitch angle, bank angle, steering angle, and the like are changed while driving a motorcycle.

[Resolution Means]

A headlight optical axis control device 10 is provided with potentiometers 121 and 122 that detect a pitch angle θ_p , an angle speed sensor 14 that detects a bank angle θ_b , a steering angle sensor 16 that detects a steering angle θ_s , a vehicle speed sensor 18 that detects a vehicle speed v , step motors 22x, 22y, 22z that pivot the optical axis of the headlight 20 in a pitch angle direction D_p , a bank angle direction D_b , and a steering angle direction D_s , and a control unit 24 that finds a pitch angle direction correction

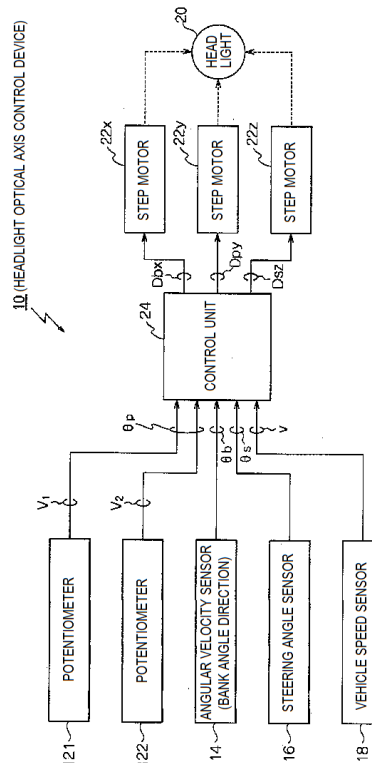

amount D_{py} , a bank angle direction correction amount D_{bx} , and a steering angle direction correction amount D_{sz} based on the detected pitch angle θ_p , bank angle θ_b , steering angle θ_s , and vehicle speed v , and corrects the angle of the optical axis through the step motors $22x$, $22y$, and $22z$.

[Scope of Claims]

[Claim 1]

A headlight optical axis control device for a motorcycle, comprising:
a pitch angle sensor that detects a pitch angle;
an actuator that pivots an optical axis of the headlight in the pitch angle direction; and
a control unit that finds a pitch angle direction correction amount based on the pitch angle detected by the pitch angle sensor and corrects the angle of the optical axis through the actuator.

[Claim 2]

A headlight optical axis control device for a motorcycle, comprising:
a bank angle sensor that detects a bank angle;
an actuator that pivots an optical axis of the headlight in the bank angle direction;
a control unit that finds a pitch angle direction correction amount based on the bank angle detected by the bank angle sensor and corrects the angle of the optical axis through the actuator.

[Claim 3]

A headlight optical axis control device for a motorcycle, comprising:
a pitch angle sensor that detects a pitch angle;
a bank angle sensor that detects a bank angle;
a vehicle speed sensor that detects a speed of a vehicle;
an actuator that pivots an optical axis of the headlight in directions of the pitch angle, the bank angle, and a steering angle; and
a control unit that finds a pitch angle direction correction amount, bank angle direction correction amount, and steering angle direction correction amount based on the pitch angle, bank angle, and vehicle speed detected by the pitch angle sensor, bank angle sensor, and vehicle speed sensor, and corrects the angle of the optical axis through the actuator.

[Claim 4]

A headlight optical axis control device of a motorcycle, comprising:
a pitch angle sensor that detects a pitch angle;
a bank angle sensor that detects a bank angle;
a steering angle sensor that detects a steering angle;
a vehicle speed sensor that detects a speed of a vehicle;
an actuator that pivots an optical axis of the headlight in directions of the pitch angle, the bank angle, and a steering angle; and
a control unit that finds a pitch angle direction correction amount, bank angle direction correction amount, and steering angle direction correction amount based on the pitch angle, bank angle, steering angle, and vehicle speed detected by the pitch angle sensor, bank angle sensor, steering angle sensor and vehicle speed sensor, and corrects the angle of the optical axis through the actuator.

[DETAILED DESCRIPTION OF THE INVENTION]

[0001]

[Technical Field of the Invention] The present invention relates to a headlight optical axis control device to keep the optical axis of a headlight of a motorcycle at a desirable angle at all times.

[0002]

[Conventional Art] In motorcycles, headlight optical axis control devices that change the optical axis of the headlight according to a vehicle speed, steering angle, bank angle, and the like have been known (Japanese Unexamined Patent Application Publication No. 63-53137, Japanese Unexamined Patent Application Publication No. 07-195794, and the like). For example, a headlight irradiates into the distance at the time of high speed, irradiates to near distance at low speed by vertically moving the headlight according to the vehicle speed, and also the headlight is swung to the right and left according to the steering and banking angles.

[0003]

[Problem to be Solved by the Invention] However, there have been the following problems in the conventional headlight optical axis control devices.

[0004] The pitch angle of a motorcycle more likely changes due to acceleration or deceleration of speed and unevenness of the road surface compared to four-wheel vehicle. However, there was no device to change the beam irradiation range of the headlight according to the pitch angle.

Therefore, the beam irradiation range of the headlight sways without being fixed when the headlight is vertically moved according to changes in the pitch angle while driving a motorcycle.

[0005] With a motorcycle, when the vehicle body is tilted in the direction of the bank angle, the beam irradiation range of the headlight flattens as illustrated in FIG. 10. This is because the optical axis of the headlight is slightly downward in the horizontal direction, and also the light flux of the headlight is not a conical shape having the optical axis as the center line, but the light flux spreads in an elliptical cone shape with a long axis in the horizontal direction. However, because the device that swings the headlight to the right and left according to the steering and banking angles swings the headlight in a direction of the steering angle, i.e., the headlight is just simply swung to the right when turning right and swung to the left when turning left, there is no solution effect on flattening of the irradiation range of the headlight. Note that, a right turn includes proceeding around a right curve, and a left turn includes proceeding around a left curve in the present specification.

[0006]

[Object of the Invention] Accordingly, an object of the present invention is to provide a headlight optical axis control device that can stably ensure a beam irradiation range of a headlight even when pitch, bank, steering angles or the like change while driving a motorcycle.

[0007]

[Means to Solve the Problem] A headlight optical axis control device for a motorcycle, according to claim 1 is provided with a pitch angle sensor that detects a pitch angle, an actuator that pivots an optical axis of the headlight in the pitch angle direction, and a control unit that finds a pitch angle direction correction amount based on the pitch angle detected by the pitch angle sensor and corrects the angle of the optical axis through the actuator.

[0008] The pitch angle sensor detects the change of the pitch angle due to an inclination of the

vehicle body. The control unit finds a pitch angle direction correction amount based on the pitch angle detected by the pitch angle sensor. The actuator pivots the optical axis of the headlight in a direction of the pitch angle according to the pitch angle direction correction amount output from the control unit. Thereby, even when the pitch angle is changed by the inclination of the vehicle body, the beam irradiation range of the head light is immediately corrected by suppressing the vertical movement of the optical axis of the headlight.

[0009] A headlight optical axis control device according to claim 2 is provided with a bank angle sensor that detects a bank angle, an actuator that pivots an optical axis of the headlight in the bank angle direction, and a control unit that finds a bank angle direction correction amount based on the bank angle detected by the bank angle sensor and corrects the angle of the optical axis through the actuator.

[0010] The bank angle sensor detects the change of the bank angle due to inclination of the vehicle body. The control unit finds a bank angle direction correction amount based on the bank angle detected by the bank angle sensor. The actuator pivots the optical axis of the headlight in a direction of the bank angle according to the bank angle direction correction amount output from the control unit. Thereby, even when the bank angle is changed due to the inclination of the vehicle body, flattening does not occur in the beam irradiation range of the headlight. This is because the long axis of the light flux spreading in the elliptical cone shape is kept in the horizontal direction at all times.

[0011] A headlight optical axis control device of a motorcycle according to claim 3 is provided with a pitch angle sensor that detects a pitch angle, a bank angle sensor that detects a bank angle, a vehicle speed sensor that detects a speed of a vehicle, an actuator that turns an optical axis of the headlight in directions of the pitch angle, the bank angle, and a steering angle, and a control unit that finds a pitch angle direction correction amount, bank angle direction correction amount, and steering angle direction correction amount based on the pitch angle, bank angle, and the vehicle speed detected by the pitch angle sensor, bank angle sensor, and vehicle speed sensor, and corrects the angle of the optical axis through the actuator.

[0012] This headlight optical axis control device is applied to a motorcycle where the headlight is fixed to the vehicle body, and by finding the steering direction correction amount in addition to the pitch angle direction correction amount and the bank angle direction correction amount, the angle of the optical axis can be corrected through the actuator for any inclination of the vehicle body.

[0013] A headlight optical axis control device of a motorcycle according to claim 4 is provided with a pitch angle sensor that detects a pitch angle, a bank angle sensor that detects a bank angle, a steering angle sensor that detects a steering angle, a vehicle speed sensor that detects a speed of a vehicle, an actuator that pivots an optical axis of the headlight in directions of the pitch angle, the bank angle, and a steering angle, and a control unit that finds a pitch angle direction correction amount, bank angle direction correction amount, and steering angle direction correction amount based on the pitch angle, bank angle, steering angle, and vehicle speed detected by the pitch angle sensor, bank angle sensor, steering angle sensor and vehicle speed sensor, and corrects the angle of the optical axis through the actuator.

Explore Litigation Insights

Docket Alarm provides insights to develop a more informed litigation strategy and the peace of mind of knowing you're on top of things.

Real-Time Litigation Alerts



Keep your litigation team up-to-date with **real-time alerts** and advanced team management tools built for the enterprise, all while greatly reducing PACER spend.

Our comprehensive service means we can handle Federal, State, and Administrative courts across the country.

Advanced Docket Research



With over 230 million records, Docket Alarm's cloud-native docket research platform finds what other services can't. Coverage includes Federal, State, plus PTAB, TTAB, ITC and NLRB decisions, all in one place.

Identify arguments that have been successful in the past with full text, pinpoint searching. Link to case law cited within any court document via Fastcase.

Analytics At Your Fingertips



Learn what happened the last time a particular judge, opposing counsel or company faced cases similar to yours.

Advanced out-of-the-box PTAB and TTAB analytics are always at your fingertips.

API

Docket Alarm offers a powerful API (application programming interface) to developers that want to integrate case filings into their apps.

LAW FIRMS

Build custom dashboards for your attorneys and clients with live data direct from the court.

Automate many repetitive legal tasks like conflict checks, document management, and marketing.

FINANCIAL INSTITUTIONS

Litigation and bankruptcy checks for companies and debtors.

E-DISCOVERY AND LEGAL VENDORS

Sync your system to PACER to automate legal marketing.