



US005546395A

United States Patent [19]

[11] Patent Number: **5,546,395**

Sharma et al.

[45] Date of Patent: **Aug. 13, 1996**

[54] **DYNAMIC SELECTION OF COMPRESSION RATE FOR A VOICE COMPRESSION ALGORITHM IN A VOICE OVER DATA MODEM**

FOREIGN PATENT DOCUMENTS

488865A2 6/1992 European Pat. Off. .
63-054052 8/1988 Japan .
2210237 1/1989 United Kingdom .

[75] Inventors: **Raghu N. Sharma**, North Oaks; **Jeffrey P. Davis**, Ham Lake; **Timothy D. Gunn**, Mounds View; **Ping Li**, New Brighton, all of Minn.; **Sidhartha Maitra**; **Ashish A. Thanawala**, both of Saratoga, Calif.

OTHER PUBLICATIONS

European Search Report for Application No. EP 93403164 completed on Sep. 21, 1995 by Examiner Lambley; 4 pages. S. Casale et al., "Statistical Voice/High-Speed Data Multiplexing on a 64 KBIT/S Channel," IEEE, pp. 459-464, dated 1991.

[73] Assignee: **Multi-Tech Systems, Inc.**, Mounds View, Minn.

T. Komiya et al, "An Approach to the Multifunction Graphic Terminal for the ISDN Environment", IEEE, pp. 32-36, dated 1988.

(List continued on next page.)

[21] Appl. No.: **346,421**

Primary Examiner—Wellington Chin
Assistant Examiner—Chau T. Nguyen
Attorney, Agent, or Firm—Schwegman, Lundberg, Woessner & Kluth, P.A.

[22] Filed: **Nov. 29, 1994**

Related U.S. Application Data

[63] Continuation-in-part of Ser. No. 271,496, Jul. 7, 1994, and a continuation-in-part of Ser. No. 2,467, Jan. 8, 1993, Pat. No. 5,452,289.

[57] ABSTRACT

[51] Int. Cl.⁶ **H04J 3/22; G10L 5/00**
[52] U.S. Cl. **370/84; 370/118; 370/112; 375/246; 395/2.28**

The present invention includes software and hardware components to enable digital data communication over standard telephone lines. The present invention converts analog voice signals to digital data, compresses that data and places the compressed speech data into packets for transfer over the telephone lines to a remote site. A voice control digital signal processor (DSP) operates to use one of a plurality of speech compression algorithms which produce a scaleable amount of compression. The rate of compression is inversely proportional to the quality of the speech the compression algorithm is able to reproduce. The higher the compression, the lower the reproduction quality. The selection of the rate of compression is dependent on such factors as the speed or data bandwidth on the communications connection between the two sites, the data demand between the sites and amount of silence detected in the speech signal. The voice compression rate is dynamically changed as the aforementioned factors change. A negotiation handshake protocol is described which enables the two sites to negotiate the compression rate based on such factors.

[58] **Field of Search** 370/94.1, 110.1, 370/118, 112, 79, 76, 82, 84, 24; 395/2, 2.2, 2.21, 2.28, 2.3, 2.31; 381/29, 32, 36, 30, 41; 375/245, 246; 455/72; 341/51

[56] References Cited

U.S. PATENT DOCUMENTS

Re. 34,034 8/1992 O'Sullivan 379/59
3,304,372 2/1967 Filipowsky et al. .
3,789,165 1/1974 Campanella et al. 179/170
3,904,830 9/1975 Every, Sr. et al. .
3,973,081 8/1976 Hutchins 395/2.28
3,997,732 12/1976 Every, Sr. et al. 179/18
4,100,377 7/1978 Flanagan 179/15
4,107,471 8/1978 Reed 179/15

(List continued on next page.)

4 Claims, 7 Drawing Sheets

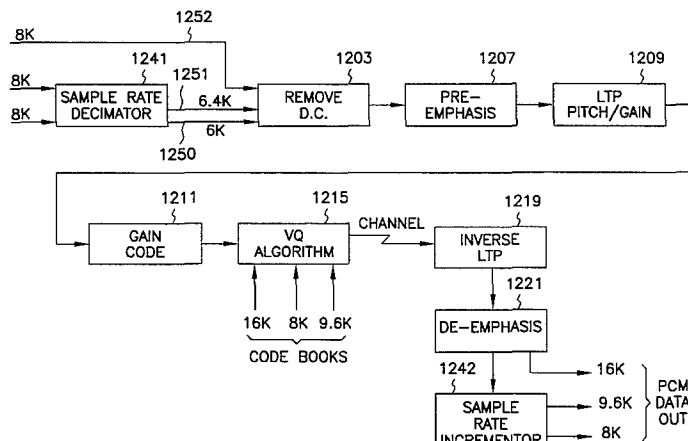

U.S. PATENT DOCUMENTS

4,205,202	5/1980	Kahn	370/81	5,046,188	9/1991	Molnar	379/94
4,284,850	8/1981	Clingenpeel	370/81	5,051,720	9/1991	Kittirutsunetorn	340/310
4,354,273	10/1982	Araseki et al.	375/245	5,062,133	10/1991	Melrose	379/94
4,377,860	3/1983	Godbole	370/84	5,065,425	11/1991	Lecomte et al.	379/93
4,403,322	9/1983	Kato et al.	370/110	5,081,647	1/1992	Bremer	375/5
4,425,661	1/1984	Moses et al.	375/1	5,083,310	1/1992	Drory	395/2.21
4,445,213	4/1984	Baugh et al.	370/94	5,086,471	2/1992	Tanaka et al.	381/36
4,476,559	10/1984	Brolin et al.	370/110	5,099,472	3/1992	Townsend et al.	370/32.1
4,479,195	10/1984	Herr et al.	364/900	5,107,519	4/1992	Ishikawa	375/27
4,479,213	10/1984	Galand et al.	370/118	5,115,429	5/1992	Hluchyj et al.	370/94.1
4,495,620	1/1985	Steele et al.	370/118	5,121,385	6/1992	Tominaga et al.	370/80
4,500,987	2/1985	Hasegawa	370/60	5,127,001	6/1992	Steagall et al.	370/62
4,524,244	6/1985	Faggin et al.		5,127,041	6/1992	O'Sullivan	379/59
4,534,024	8/1985	Maxemchuk et al.	370/85	5,132,966	7/1992	Hayano et al.	370/79
4,546,212	10/1985	Crowder, Sr.	179/2	5,136,586	8/1992	Greenblatt	370/110
4,578,537	3/1986	Faggin et al.	179/2	5,138,662	8/1992	Amano et al.	395/2.28
4,587,651	5/1986	Nelson et al.	370/88	5,146,470	9/1992	Fujii et al.	375/103
4,593,389	6/1986	Wurzburg et al.	370/110	5,150,410	9/1992	Bertrand	380/28
4,609,788	9/1986	Miller et al.	179/170.6	5,151,937	9/1992	Chujo et al.	379/410
4,629,829	12/1986	Puhl et al.	379/58	5,153,897	10/1992	Sumiyoshi et al.	375/8
4,652,703	3/1987	Lu et al.	379/339	5,162,812	11/1992	Aman et al.	375/34
4,660,218	4/1987	Hashimoto	379/93	5,177,734	1/1993	Cummiskey et al.	370/32
4,670,874	6/1987	Sato et al.	370/110.1	5,182,762	1/1993	Shirai et al.	375/122
4,697,281	9/1987	O'Sullivan	379/59	5,187,591	2/1993	Guy et al.	358/425
4,700,341	10/1987	Huang	370/80	5,187,692	2/1993	Haneda et al.	367/135
4,707,831	11/1987	Weir et al.	370/94	5,193,110	3/1993	Jones et al.	379/94
4,718,082	1/1988	Parker et al.	379/98	5,195,130	3/1993	Weiss et al.	379/90
4,740,963	4/1988	Eckley	370/110.1	5,208,812	5/1993	Dudek et al.	370/100.1
4,750,169	6/1988	Carse et al.	370/109	5,208,850	5/1993	Kino	379/88
4,751,510	6/1988	De Saint Michel et al.	340/825.07	5,214,656	5/1993	Chung et al.	371/43
4,751,736	6/1988	Gupta et al.	395/2.21	5,228,026	7/1993	Albrow et al.	370/29
4,757,527	7/1988	Beniston et al.	379/410	5,233,660	8/1993	Chen	381/38
4,764,955	8/1988	Galand et al.	379/411	5,235,595	8/1993	O'Dowd	370/94.1
4,807,250	2/1989	Tanaka	375/245	5,249,218	9/1993	Sainton	379/59
4,809,271	2/1989	Kondo et al.	370/110.1	5,258,983	11/1993	Lane et al.	370/118
4,813,040	3/1989	Futato	370/111	5,261,027	11/1993	Taniguchi et al.	395/2
4,827,085	5/1989	Yaniv et al.	178/18	5,263,019	11/1993	Chu	370/32
4,835,765	5/1989	Bergmans et al.	370/32	5,272,695	12/1993	Makino et al.	370/32.1
4,839,802	6/1989	Wonak et al.	364/200	5,276,703	1/1994	Budin et al.	375/1
4,845,746	7/1989	Li	379/411	5,278,900	1/1994	Van Gerwen et al.	379/410
4,847,900	7/1989	Wakim	379/424	5,282,197	1/1994	Kreitzer	370/76
4,862,449	8/1989	Hoefkens et al.	370/32	5,283,638	2/1994	Engberg et al.	348/14
4,866,732	9/1989	Carey et al.	375/1	5,283,819	2/1994	Glick et al.	379/90
4,887,265	12/1989	Felix	370/94.1	5,289,539	2/1994	Maruyama	379/410
4,890,282	12/1989	Lambert et al.	370/79	5,295,136	3/1994	Ashley et al.	370/32
4,901,333	2/1990	Hodgkiss	375/98	5,305,312	4/1994	Fornek et al.	370/62
4,905,282	2/1990	McGlynn et al.	380/48	5,307,413	4/1994	Denzer	380/49
4,912,758	3/1990	Arbel	379/388	5,309,562	5/1994	Li	
4,914,650	4/1990	Sriram	370/60	5,313,498	5/1994	Sano	375/103
4,926,448	5/1990	Kraul et al.	375/121	5,317,604	5/1994	Osterweil	375/122
4,932,048	6/1990	Kenmochi et al.	379/67	5,319,682	6/1994	Clark	375/122
4,935,954	6/1990	Thompson et al.	379/89	5,327,520	7/1994	Chen	395/2
4,942,569	7/1990	Maeno	370/60	5,329,472	7/1994	Sugiyama	364/724
4,953,210	8/1990	McGlynn et al.	380/48	5,341,374	8/1994	Lewen et al.	370/85.4
4,965,789	10/1990	Bottau et al.	370/79	5,343,473	8/1994	Cidon et al.	370/85.6
4,972,457	11/1990	O'Sullivan	379/59	5,343,521	8/1994	Jullien et al.	379/410
4,972,462	11/1990	Shibata	379/89	5,371,853	12/1994	Kao et al.	395/2.32
4,972,483	11/1990	Carey	395/2.21	5,406,560	4/1995	Kondo et al.	375/245
4,977,591	12/1990	Chen et al.	379/410	5,414,796	5/1995	Jacobs	395/2.3
4,991,169	2/1991	Davis et al.	370/77				
4,995,059	2/1991	Ishikawa	375/27				
4,998,241	3/1991	Brox et al.	370/32.1				
5,001,710	3/1991	Gawrys et al.	370/110.1				
5,001,745	3/1991	Pollock	379/96				
5,005,183	4/1991	Carey et al.	375/1				
5,008,926	4/1991	Misholi	379/89				
5,014,232	5/1991	André	364/724				
5,020,058	5/1991	Holden et al.	370/109				
5,036,513	7/1991	Greenblatt	370/125				

OTHER PUBLICATIONS

- D. Gulick et al., "Interface for the ISDN to Your PC with A Voice/Data Board", *Electronic Design*, pp. 85-88, dated Dec. 10, 1987.
- S. Sasaki et al., "Variable Rate Voice Coding System", IEEE, pp. 364-367, dated 1992.
- AT&T Microelectronics, "High Speed Data Pump Chip Sets", published in Dec. 1991.
- AT&T Microelectronics, "WE DSP16C Digital Signal Processor/CODEC Preliminary Data Sheet" 32 pages, May

AT&T Microelectronics, "T7540 Digital Telephone CODEC Data Sheet Addendum", pp. 1-4, published in Jul., 1991.

AT&T Microelectronics, "T7540 Digital Telephone CODEC Preliminary Data Sheet", pp. 1-64, published in Jan., 1991.

Zilog Intelligent Peripheral Controllers, "Z84C01 Z80 CPU with Clock Generator/Controller," pp. 43-73, published in 1991.

Zilog Intelligent Peripheral Controllers, "Z84C90 CMOS Z80 KIO Serial/Parallel/counter/timer," pp. 205-224, published in 1991.

U.S. West Caller ID publication, received Jul. 18, 1994, one page.

J. D. Mills, et al., "A Data and Boice System for the General Service Telephone Network," *IECON*, pp. 1143-1148, 1987.

Copy of European Search Report (Application No. EP 94304742), completed Jun. 8, 1995 by Examiner Mikkelsen.

"TechTips—A Periodic Round-up of Technical Applications, Notes, and Information on MultiTech's Data Communications Products" by MultiTech Systems, vol. 2, No. 2, May 1992.

"MultiX25—X.25 PAD, The New MultiX25 PAD 8 Port X.25 Packet Assembler/Disassembler for Public and Private Data Networks," by MultiTech Systems. Mar. 1992 (2 pages).

Y. Akaiwa et al., "An Integrated Voice and Data Radio Access System," 1992, pp. 255-258, IEEE.

CCITT V.42, "Error-Correcting Procedures for DCES Using Asynchronous-to-Synchronous Conversion", vol. VIII, pp. 296-370, dated 1988.

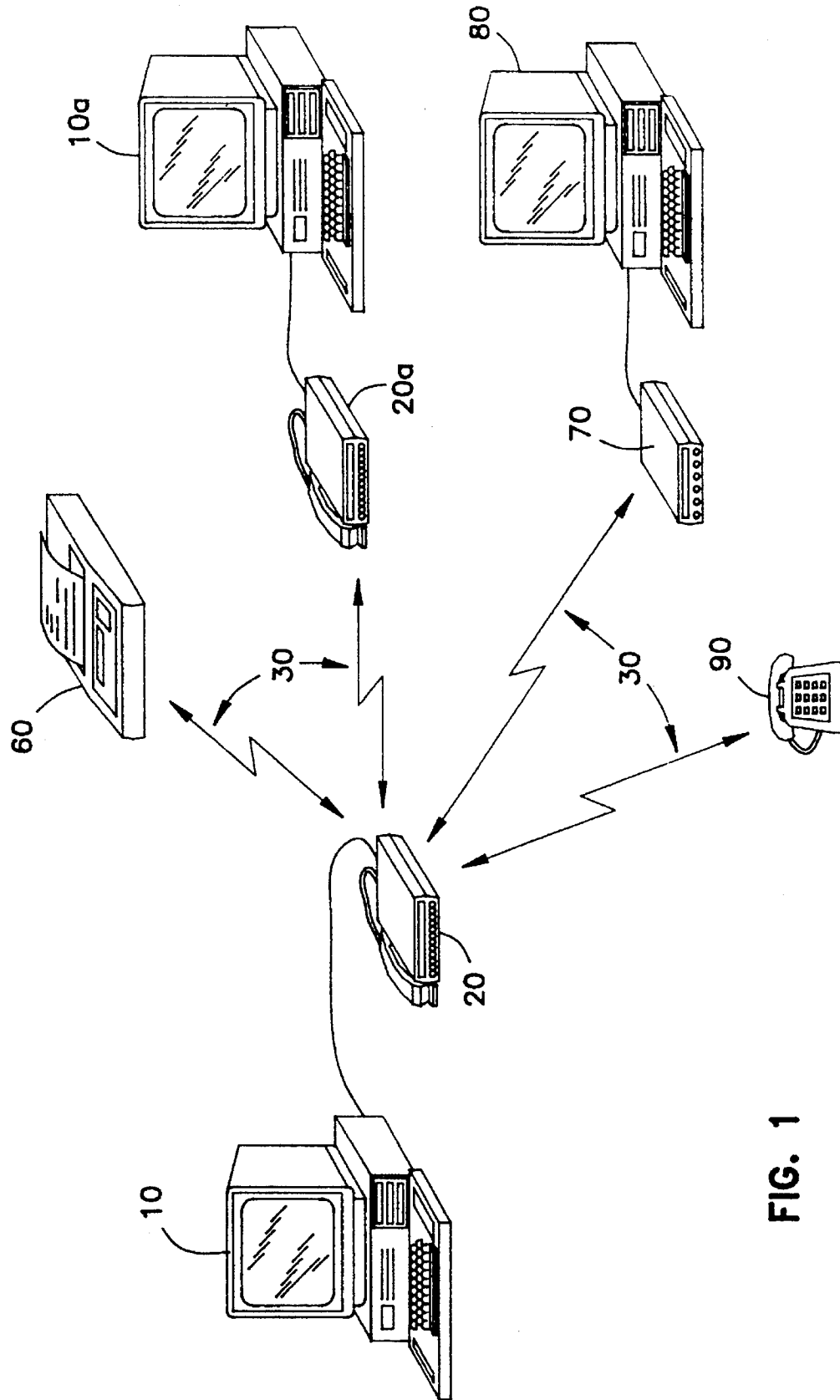

FIG. 1

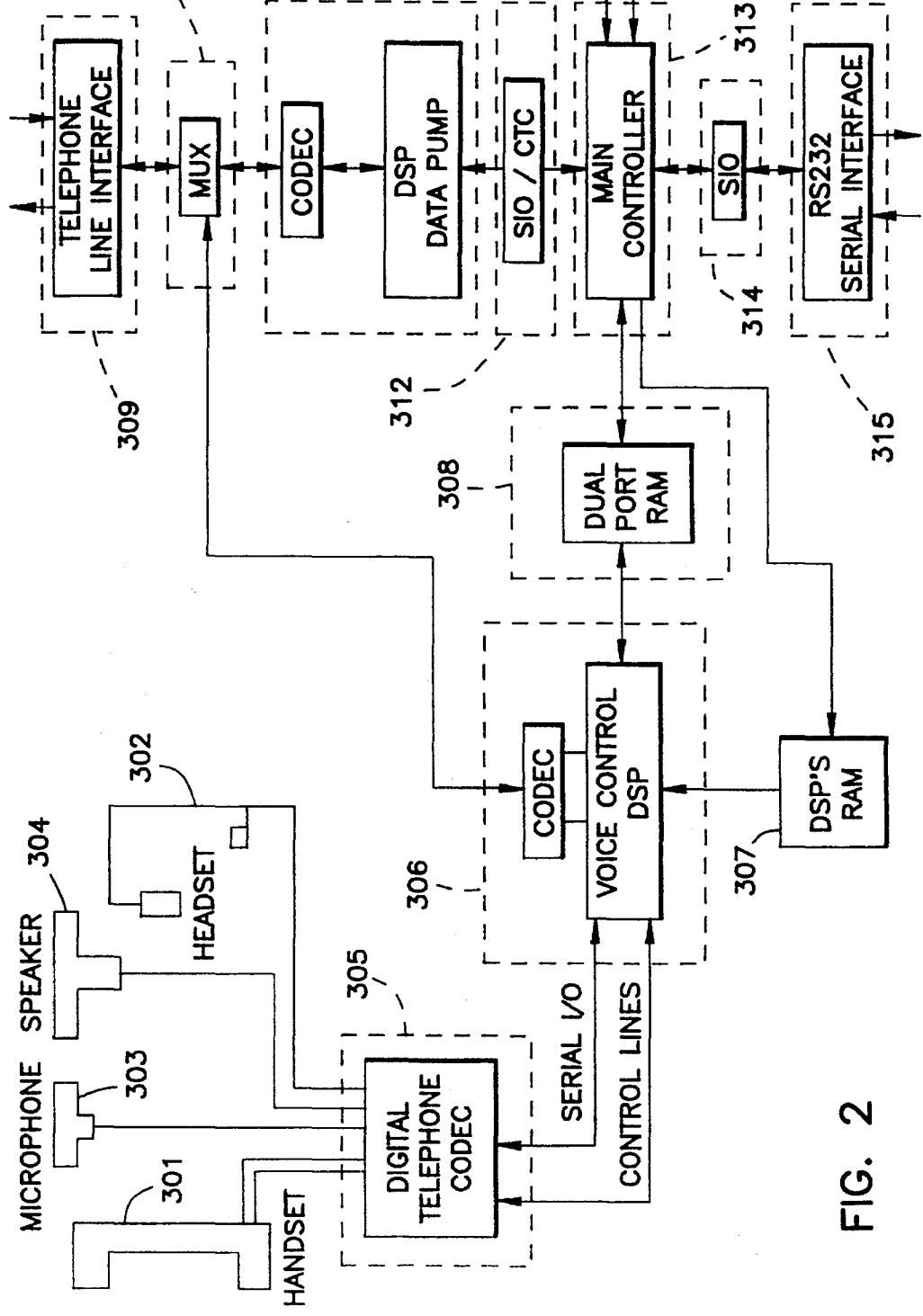

FIG. 2

Explore Litigation Insights

Docket Alarm provides insights to develop a more informed litigation strategy and the peace of mind of knowing you're on top of things.

Real-Time Litigation Alerts



Keep your litigation team up-to-date with **real-time alerts** and advanced team management tools built for the enterprise, all while greatly reducing PACER spend.

Our comprehensive service means we can handle Federal, State, and Administrative courts across the country.

Advanced Docket Research



With over 230 million records, Docket Alarm's cloud-native docket research platform finds what other services can't. Coverage includes Federal, State, plus PTAB, TTAB, ITC and NLRB decisions, all in one place.

Identify arguments that have been successful in the past with full text, pinpoint searching. Link to case law cited within any court document via Fastcase.

Analytics At Your Fingertips



Learn what happened the last time a particular judge, opposing counsel or company faced cases similar to yours.

Advanced out-of-the-box PTAB and TTAB analytics are always at your fingertips.

API

Docket Alarm offers a powerful API (application programming interface) to developers that want to integrate case filings into their apps.

LAW FIRMS

Build custom dashboards for your attorneys and clients with live data direct from the court.

Automate many repetitive legal tasks like conflict checks, document management, and marketing.

FINANCIAL INSTITUTIONS

Litigation and bankruptcy checks for companies and debtors.

E-DISCOVERY AND LEGAL VENDORS

Sync your system to PACER to automate legal marketing.