

INTERNATIONAL
STANDARD

ISO/IEC
11172-1

First edition
1993-08-01

**Information technology — Coding of
moving pictures and associated audio for
digital storage media at up to about
1,5 Mbit/s —**

**Part 1:
Systems**

*Technologies de l'information — Codage de l'image animée et du son
associé pour les supports de stockage numérique jusqu'à environ
1,5 Mbit/s —*

Partie 1: Systèmes



Reference number
ISO/IEC 11172-1:1993(E)

Contents

Page

Foreword.....	iii
Introduction.....	iv
Section 1: General.....	1
1.1 Scope.....	1
1.2 Normative references.....	1
Section 2: Technical elements.....	3
2.1 Definitions.....	3
2.2 Symbols and abbreviations.....	11
2.3 Method of describing bit stream syntax.....	13
2.4 Requirements.....	15
Annexes	
A Description of the system coding layer.....	29
B List of patent holders.....	50

© ISO/IEC 1993

All rights reserved. No part of this publication may be reproduced or utilized in any form or by any means, electronic or mechanical, including photocopying and microfilm, without permission in writing from the publisher.

ISO/IEC Copyright Office • Case Postale 56 • CH1211 Genève 20 • Switzerland

Printed in Switzerland.

Foreword

ISO (the International Organization for Standardization) and IEC (the International Electrotechnical Commission) form the specialized system for worldwide standardization. National bodies that are members of ISO or IEC participate in the development of International Standards through technical committees established by the respective organization to deal with particular fields of technical activity. ISO and IEC technical committees collaborate in fields of mutual interest. Other international organizations, governmental and non-governmental, in liaison with ISO and IEC, also take part in the work.

In the field of information technology, ISO and IEC have established a joint technical committee, ISO/IEC JTC 1. Draft International Standards adopted by the joint technical committee are circulated to national bodies for voting. Publication as an International Standard requires approval by at least 75 % of the national bodies casting a vote.

International Standard ISO/IEC 11172-1 was prepared by Joint Technical Committee ISO/IEC JTC 1, *Information technology*, Sub-Committee SC 29, *Coded representation of audio, picture, multimedia and hypermedia information*.

ISO/IEC 11172 consists of the following parts, under the general title *Information technology — Coding of moving pictures and associated audio for digital storage media at up to about 1,5 Mbit/s*:

- *Part 1: Systems*
- *Part 2: Video*
- *Part 3: Audio*
- *Part 4: Compliance testing*

Annexes A and B of this part of ISO/IEC 11172 are for information only.

Introduction

Note -- Readers interested in an overview of the MPEG Systems layer should read this Introduction and then proceed to annex A, before returning to the clauses 1 and 2. Since the system target decoder concept is referred to throughout both the normative and informative clauses of this part of ISO/IEC 11172, it may also be useful to refer to clause 2.4, and particularly 2.4.2, where the system target decoder is described.

The systems specification addresses the problem of combining one or more data streams from the video and audio parts of this International Standard with timing information to form a single stream. Once combined into a single stream, the data are in a form well suited to digital storage or transmission. The syntactical and semantic rules imposed by this systems specification enable synchronized playback without overflow or underflow of decoder buffers under a wide range of stream retrieval or receipt conditions. The scope of syntactical and semantic rules set forth in the systems specification differ: the syntactical rules apply to systems layer coding only, and do not extend to the compression layer coding of the video and audio specifications; by contrast, the semantic rules apply to the combined stream in its entirety.

The systems specification does not specify the architecture or implementation of encoder or decoders. However, bitstream properties do impose functional and performance requirements on encoders and decoders. For instance, encoders must meet minimum clock tolerance requirements. Notwithstanding this and other requirements, a considerable degree of freedom exists in the design and implementation of encoders and decoders.

A prototypical audio/video decoder system is depicted in figure 1 to illustrate the function of an ISO/IEC 11172 decoder. The architecture is not unique -- System Decoder functions including decoder timing control might equally well be distributed among elementary stream decoders and the Medium Specific Decoder -- but this figure is useful for discussion. The prototypical decoder design does not imply any normative requirement for the design of an ISO/IEC 11172 decoder. Indeed non-audio/video data is also allowed, but not shown.

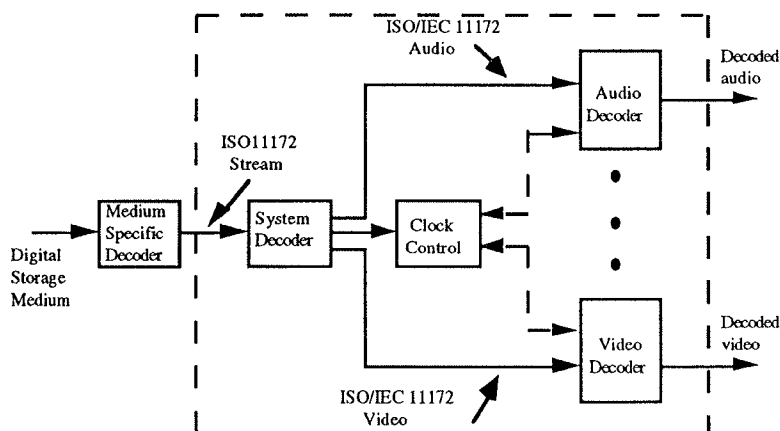

Figure 1 -- Prototypical ISO/IEC 11172 decoder

The prototypical ISO/IEC 11172 decoder shown in figure 1 is composed of System, Video, and Audio decoders conforming to Parts 1, 2, and 3, respectively, of ISO/IEC 11172. In this decoder the multiplexed coded representation of one or more audio and/or video streams is assumed to be stored on a digital storage medium (DSM), or network, in some medium-specific format. The medium specific format is not governed by this International Standard, nor is the medium-specific decoding part of the prototypical ISO/IEC 11172 decoder.

The prototypical decoder accepts as input an ISO/IEC 11172 multiplexed stream and relies on a System Decoder to extract timing information from the stream. The System Decoder demultiplexes the stream, and the elementary streams so produced serve as inputs to Video and Audio decoders, whose outputs are decoded video and audio signals. Included in the design, but not shown in the figure, is the flow of timing information among the System Decoder, the Video and Audio Decoders, and the Medium Specific Decoder.

The Video and Audio Decoders are synchronized with each other and with the DSM using this timing information.

ISO/IEC 11172 multiplexed streams are constructed in two layers: a system layer and a compression layer. The input stream to the System Decoder has a system layer wrapped about a compression layer. Input streams to the Video and Audio decoders have only the compression layer.

Operations performed by the System Decoder either apply to the entire ISO/IEC 11172 multiplexed stream ("multiplex-wide operations"), or to individual elementary streams ("stream-specific operations"). The ISO/IEC 11172 system layer is divided into two sub-layers, one for multiplex-wide operations (the pack layer), and one for stream-specific operations (the packet layer).

0.1 Multiplex-wide operations (pack layer)

Multiplex-wide operations include the coordination of data retrieval off the DSM, the adjustment of clocks, and the management of buffers. The tasks are intimately related. If the rate of data delivery off the DSM is controllable, then DSM delivery may be adjusted so that decoder buffers neither overflow nor underflow; but if the DSM rate is not controllable, then elementary stream decoders must slave their timing to the DSM to avoid overflow or underflow.

ISO/IEC 11172 multiplexed streams are composed of packs whose headers facilitate the above tasks. Pack headers specify intended times at which each byte is to enter the system decoder from the DSM, and this target arrival schedule serves as a reference for clock correction and buffer management. The schedule need not be followed exactly by decoders, but they must compensate for deviations about it.

An additional multiplex-wide operation is a decoder's ability to establish what resources are required to decode an ISO/IEC 11172 multiplexed stream. The first pack of each ISO/IEC 11172 multiplexed stream conveys parameters to assist decoders in this task. Included, for example, are the stream's maximum data rate and the highest number of simultaneous video channels.

0.2 Individual stream operations (packet layer)

The principal stream-specific operations are 1) demultiplexing, and 2) synchronizing playback of multiple elementary streams. These topics are discussed next.

0.2.1 Demultiplexing

On encoding, ISO/IEC 11172 multiplexed streams are formed by multiplexing elementary streams. Elementary streams may include private, reserved, and padding streams in addition to ISO/IEC 11172 audio and video streams. The streams are temporally subdivided into packets, and the packets are serialized. A packet contains coded bytes from one and only one elementary stream.

Both fixed and variable packet lengths are allowed subject to constraints in 2.4.3.3 and in 2.4.5 and 2.4.6.

On decoding, demultiplexing is required to reconstitute elementary streams from the ISO/IEC 11172 multiplexed stream. This is made possible by stream_id codes in packet headers.

0.2.2 Synchronization

Synchronization among multiple streams is effected with presentation time stamps in the ISO/IEC 11172 multiplexed stream. The time stamps are in units of 90kHz. Playback of N streams is synchronized by adjusting the playback of all streams to a master time base rather than by adjusting the playback of one stream to match that of another. The master time base may be one of the N decoders' clocks, the DSM or channel clock, or it may be some external clock.

Because presentation time-stamps apply to the decoding of individual elementary streams, they reside in the packet layer. End-to-end synchronization occurs when encoders record time-stamps at capture time, when the time stamps propagate with associated coded data to decoders, and when decoders use those time-stamps to schedule presentations.

Synchronization is also possible with DSM timing time stamps in the multiplexed data stream.

Explore Litigation Insights

Docket Alarm provides insights to develop a more informed litigation strategy and the peace of mind of knowing you're on top of things.

Real-Time Litigation Alerts



Keep your litigation team up-to-date with **real-time alerts** and advanced team management tools built for the enterprise, all while greatly reducing PACER spend.

Our comprehensive service means we can handle Federal, State, and Administrative courts across the country.

Advanced Docket Research



With over 230 million records, Docket Alarm's cloud-native docket research platform finds what other services can't. Coverage includes Federal, State, plus PTAB, TTAB, ITC and NLRB decisions, all in one place.

Identify arguments that have been successful in the past with full text, pinpoint searching. Link to case law cited within any court document via Fastcase.

Analytics At Your Fingertips



Learn what happened the last time a particular judge, opposing counsel or company faced cases similar to yours.

Advanced out-of-the-box PTAB and TTAB analytics are always at your fingertips.

API

Docket Alarm offers a powerful API (application programming interface) to developers that want to integrate case filings into their apps.

LAW FIRMS

Build custom dashboards for your attorneys and clients with live data direct from the court.

Automate many repetitive legal tasks like conflict checks, document management, and marketing.

FINANCIAL INSTITUTIONS

Litigation and bankruptcy checks for companies and debtors.

E-DISCOVERY AND LEGAL VENDORS

Sync your system to PACER to automate legal marketing.