

*In addition to varying the time of incubation, the amount of thrombin and the temperature of incubation (up to 37°C) may also be varied to determine the optimum conditions for cleavage of a particular fusion protein.*

## ENZYMATIC CLEAVAGE OF MATRIX-BOUND GST FUSION PROTEINS

### ALTERNATE PROTOCOL 2

In this alternate protocol, GST fusion proteins that contain a thrombin cleavage site are bound to glutathione-agarose as described in UNIT 16.7. Prior to elution from the matrix, thrombin is added and the protein of interest is cleaved from the GST carrier. The cleaved protein is collected in the wash buffer and the GST carrier remains bound to the beads, permitting easy and efficient physical separation of the reaction products.

### Additional Materials

*For recipes, see Reagents and Solutions in this unit (or cross-referenced unit); for common stock solutions, see APPENDIX 2; for suppliers, see APPENDIX 4.*

GST fusion protein bound to glutathione-agarose beads (UNIT 16.7)  
1% (v/v) Triton X-100 in phosphate-buffered saline (PBS; APPENDIX 2)  
GST wash buffer: 50 mM Tris-Cl (pH 7.5)/150 mM NaCl  
GST elution buffer: 50 mM Tris-Cl (pH 8.0)/5 mM reduced glutathione  
20- or 50- ml screw-cap tube

1. Wash GST fusion protein bound to glutathione-agarose beads with 20 vol of 1% Triton X-100 in PBS, using a 20- or 50-ml screw-cap tube. Centrifuge 10 sec in a tabletop centrifuge at 500×g, room temperature, to pellet the beads. Carefully remove and discard the supernatant. Resuspend the beads in 20 vol Triton X-100 buffer and repeat wash.
2. After the second centrifugation, carefully remove and discard the supernatant. Resuspend the beads in 20 vol GST wash buffer.
3. Pellet the beads and discard the supernatant. Resuspend the beads in 20 vol thrombin cleavage buffer. Repeat the centrifugation and resuspend the beads in ≤1 ml thrombin cleavage buffer.

*Although it is easier to wash the beads in large volumes, the amount of thrombin cleavage buffer to use in the cleavage reaction is best kept to a minimum.*

4. Remove a small aliquot of resuspended beads and add an equal volume of 2× SDS sample buffer. Store at -20°C until analyzed by SDS-PAGE (step 7).

*This sample is used to estimate the amount of fusion protein bound to the beads.*

5. Add thrombin to the remaining bead slurry at a ratio of 1% (w/w) thrombin to the estimated amount of bound fusion protein. Incubate 1 hr at 25°C.

*As in solution cleavage, the amount of thrombin, time, and temperature of incubation can be adjusted to optimize the cleavage efficiency.*

6. Elute the cleaved and released protein by washing the beads with 1 bed volume of GST wash buffer. Centrifuge as in step 1 to pellet beads and collect supernatant. Repeat five times, but keep each wash fraction separate. Remove 20-μl aliquots from each wash fraction for SDS-PAGE.
7. Elute bound GST by repeating step 6 with GST elution buffer instead of GST wash buffer. Remove 20-μl aliquots from each fraction and analyze by SDS-PAGE to determine extent of cleavage. Include the aliquot of beads from step 4 on this gel.

If cleavage is incomplete, the time of incubation and/or the amount of enzyme can be increased.

Because this is an analytical-scale experiment, it is easiest to discard these beads after one use. Upon scaling up the procedure, the beads can be regenerated, as described in *Reagents and Solutions*, UNIT 16.7.

### ALTERNATE PROTOCOL 3

## ENZYMATIC CLEAVAGE OF FUSION PROTEINS WITH ENTEROKINASE

Enterokinase (also called enteropeptidase) is a mammalian trypsin-like serine protease that displays a high degree of specificity for the sequence (Asp)<sub>4</sub>-Lys, cleaving on the carboxy-terminal side of the lysine residue of the recognition sequence. Although in mammals the enzyme has evolved to recognize and cleave this sequence from the amino-termini of trypsinogens, it has been shown that enterokinase is also capable of cleaving fusion proteins that are expressed in bacteria and that contain this recognition sequence inserted between the carrier protein and the carboxy-terminal fusion partner. Enterokinase is capable of cleaving fusion proteins under a wide range of reaction conditions, with pH ranging from 4.5 to 9.5 and temperatures ranging from 4° to 45°C. Enterokinase is also extremely tolerant of the nature of the amino acid residue in the P1' position (except that the peptide bond between Lys-Pro at this position is totally refractory to cleavage; E. LaVallie and L. Racie, unpub. observ.). At sufficiently low ionic strength, enterokinase can cleave fusion proteins at a weight ratio of 1:500 to 1:2000. At these ratios, typical cleavage reactions are carried out for 16 to 24 hr at 37°C, but these parameters (time, temperature, and enzyme/substrate ratio) can be adjusted as needed.

The thioredoxin fusion vector pTRXFUS (UNIT 16.8) encodes an enterokinase cleavage site immediately preceding the polylinker cloning region. Proteins produced as Trx fusions using this system can be subsequently released by incubation with enterokinase, leaving their authentic amino-terminal sequence. The protocol below describes the use of bovine enterokinase in this application.

### *Additional Materials*

*For recipes, see Reagents and Solutions in this unit (or cross-referenced unit); for common stock solutions, see APPENDIX 2; for suppliers, see APPENDIX 4.*

- 1 mg/ml thioredoxin fusion protein (UNIT 16.8) in 50 mM Tris-Cl (pH 8.0)/1 mM CaCl<sub>2</sub>
- 10 µg/ml bovine enterokinase (Biozyme EK-3 grade) in 50 mM Tris-Cl (pH 8.0)/1 mM CaCl<sub>2</sub>

**NOTE:** Many commercial preparations of enterokinase (bovine or porcine), with the exception of the source listed, are extremely impure and tend to be contaminated with, among other things, trypsin and chymotrypsin which can extensively degrade the fusion protein. It is recommended that only commercial enterokinase of the highest quality be used.

1. Perform a pilot experiment to monitor the efficiency of cleavage with various ratios of enterokinase to fusion protein. Prepare five reactions:

*Reactions 1 to 4:* 20 µl of 1 mg/ml fusion protein, 1 µl, 2 µl, 5 µl, and 10 µl of 10 µg/ml bovine enterokinase, and 50 mM Tris-Cl (pH 8.0)/1 mM CaCl<sub>2</sub>, to a total of 30 µl.

*Reaction 5:* 20 µl of 1 mg/ml fusion protein and 10 µl of 50 mM Tris-Cl (pH 8.0)/1 mM CaCl<sub>2</sub> (mock digestion).

Incubate samples ≥ 16 hr at 37°C.

*The fusion protein must be (at least) partially purified prior to digestion with enterokinase because the enzyme is inactive in crude bacterial lysates.*

2. Stop the reaction by adding 30  $\mu$ l of 2 $\times$  SDS sample buffer to each reaction. Boil 10 min.

*For larger-scale applications, the reaction can be stopped by adding p-aminobenzamide (PABA) to 5 mM. PABA is a competitive inhibitor of most intestinal serine proteases. It should provide protection from nonspecific proteolysis of the reaction products by contaminants in the enzyme preparation before the protein of interest is purified further.*

3. Load 10  $\mu$ l of each sample onto an SDS-polyacrylamide gel to analyze the extent of cleavage. Adjust enterokinase concentration and length of incubation accordingly to accomplish complete digestion.
4. Scale up the reaction components linearly to digest a larger amount of fusion protein.

*Calcium ions marginally increase the efficiency of cleavage, but their presence sometimes promotes fusion protein degradation by stimulating contaminating proteolytic activities. If degradation of the cleaved fusion protein occurs, omit calcium and add 5 mM EDTA to the cleavage reaction to try to eliminate the problem.*

## CHEMICAL CLEAVAGE OF FUSION PROTEINS USING CYANOGEN BROMIDE

## BASIC PROTOCOL 2

Cyanogen bromide (CNBr) has been used to cleave proteins at methionine residues for many years. CNBr has been used industrially for the production of both somatostatin (Itakura et al., 1977) and insulin (Chance et al., 1981). The reaction is typically carried out at low pH in 70% formic acid, and cleavage occurs at the C-terminal side of methionine residues. The protein concentration is relatively unimportant, as the CNBr is in vast excess for hydrolysis. The technique is useful only if the protein of interest lacks methionine residues. Cleavage with CNBr is usually efficient, but side chain modifications and nonspecific cleavages are common upon prolonged incubation at low pH. These problems, along with the potential for reduction of intramolecular disulfide bonds during treatment with 70% formic acid, can be minimized by replacing the formic acid with 6 M guanidine-HCl/0.2 M HCl.

**CAUTION:** Cyanogen bromide is extremely toxic. It should only be used in a properly ventilated fume hood. Exercise appropriate caution in its use and disposal.

### Materials

*For recipes, see Reagents and Solutions in this unit (or cross-referenced unit); for common stock solutions, see APPENDIX 2; for suppliers, see APPENDIX 4.*

- 1 mg/ml fusion protein
- 50 mg/ml cyanogen bromide (CNBr)/70% (v/v) formic acid
- 70% (v/v) formic acid
- 1 $\times$  SDS sample buffer (UNIT 10.2)

Additional reagents and equipment for SDS-PAGE (UNIT 10.2)

1. Perform a pilot experiment to determine minimum incubation time. Lyophilize two 50- $\mu$ l aliquots of fusion protein solution. Resuspend one aliquot in 50  $\mu$ l of 50 mg/ml CNBr/70% formic acid. Resuspend the other in 50  $\mu$ l of 70% formic acid *without* CNBr. Incubate at room temperature.
2. At 0, 8, 24, and 48 hr, remove a 5- $\mu$ l aliquot and lyophilize.

## Protein Expression

### 16.4.11

3. Resuspend all aliquots in 20  $\mu$ l of 1 $\times$  SDS sample buffer, boil 10 min, and load onto an SDS-polyacrylamide gel.
4. Based on analysis of the gel, determine the minimum incubation time necessary to completely cleave the protein.

*The protocol can be easily scaled up to accommodate larger amounts of fusion protein. Some proteins are resistant to cleavage with cyanogen bromide. In such cases, or when the fusion protein to be cleaved is insoluble, guanidine-HCl can be added to the reaction at a final concentration of 6 M.*

#### ALTERNATE PROTOCOL 4

### CHEMICAL CLEAVAGE OF FUSION PROTEINS USING HYDROXYLAMINE

Hydroxylamine cleaves proteins at Asn-Gly bonds and can be used as a reagent for chemical cleavage of fusion proteins. This cleavage site is less common than that for cyanogen bromide, and therefore the presence of a susceptible bond in the protein of interest is less likely. One disadvantage is that the released carboxy-terminal fusion partner will retain a glycine residue at its amino terminus, which is unacceptable in some applications. Also, the reaction requires incubation of the fusion protein at alkaline pH, which may cause modification of some amino acid side chains. Finally, protein digestions by this technique are usually incomplete due to the nature of the cleavage mechanism (E.L., unpub. observ.), reducing yield and possibly complicating post-cleavage purification of the desired protein product. However, the technique does have advantages: speed, economy, and the ability to perform digestions under denaturing conditions (e.g., 6 M guanidine-HCl) for otherwise insoluble fusion proteins.

**CAUTION:** Hydroxylamine is potentially explosive if mishandled. Be sure to follow all precautions indicated by the manufacturer.

#### *Additional Materials*

*For recipes, see Reagents and Solutions in this unit (or cross-referenced unit); for common stock solutions, see APPENDIX 2; for suppliers, see APPENDIX 4.*

- 1 mg/ml fusion protein in 10 mM Tris·Cl (pH 8.0)/150 mM NaCl
- 2 $\times$  hydroxylamine cleavage solution (see recipe)
- Guanidine-HCl (optional)
- 2 $\times$  SDS sample buffer (UNIT 10.2)
- Boiling water bath

1. Perform a pilot experiment to determine minimum incubation time. Mix 50  $\mu$ l of 1 mg/ml fusion protein in 10 mM Tris·Cl (pH 8.0)/150 mM NaCl with 50  $\mu$ l of 2 $\times$  hydroxylamine cleavage solution in a 1.5-ml microcentrifuge tube. Incubate at 45°C.

*If the fusion protein is insoluble, guanidine-HCl can be added to the cleavage reaction at a final concentration of 6 M. This may also help in cases where a particular Asn-Gly bond appears to be resistant to cleavage.*

2. At 0, 2, 4, 8, 16, and 24 hr, remove 10- $\mu$ l aliquots from the cleavage reaction and mix with 10  $\mu$ l of 2 $\times$  SDS sample buffer. Freeze each tube on dry ice until all time points have been collected.
4. Heat samples 10 min in a boiling water bath. Load all samples onto an SDS-polyacrylamide gel to analyze the extent of cleavage.
5. Determine the minimum incubation time necessary for maximum cleavage.

*If cleavage after 24 hr is still poor, add guanidine-HCl to 6 M final, increase hydroxylamine concentration to 3 M final, or both.*

## CHEMICAL CLEAVAGE OF FUSION PROTEINS BY HYDROLYSIS AT LOW pH

This method exploits the fact that the Asp-Pro bond is labile at low pH. Hydrolysis of this peptide bond occurs at elevated temperatures (37° to 40°C) under acidic conditions (pH 2.5). Nonspecific cleavages can occur upon prolonged incubation under these conditions, and it is necessary to determine empirically the minimum length of time necessary for cleavage. Like the other chemical cleavage methods described in this unit, the reaction conditions are somewhat harsh and may result in denaturation or modification of the protein. On the other hand, this treatment allows insoluble fusion proteins to be cleaved by acid hydrolysis of Asp-Pro bonds in the presence of 6 M guanidine·HCl. To use this procedure the amino acid sequence of the carboxy-terminal fusion partner should first be examined carefully to verify the absence of other Asp-Pro bonds. The released protein will retain a proline residue at its amino-terminus.

This method will potentially cleave any protein containing an Asp-Pro bond. The GST fusion vector pGEX1 (UNIT 16.7, and Fig. 16.7.1 therein) contains an Asp-Pro cleavage site encoded by the *Bam*HI site of the polylinker cloning region, so fusions at this site will result in fusion proteins that can be released from GST using this protocol.

### Additional Materials

For recipes, see *Reagents and Solutions* in this unit (or cross-referenced unit); for common stock solutions, see APPENDIX 2; for suppliers, see APPENDIX 4.

Fusion protein containing an Asp-Pro bond between the component domains  
70% (v/v) formic acid  
13% (v/v) acetic acid  
0.1 M Tris base  
Guanidine·HCl

1. Perform a pilot experiment to determine optimal hydrolysis conditions. Prepare four reaction mixtures:

*Reaction 1:* ~20 µg fusion protein in 70% formic acid

*Reaction 2:* ~20 µg fusion protein in 70% formic acid/6 M guanidine·HCl

*Reaction 3:* ~20 µg fusion protein in 13% acetic acid

*Reaction 4:* ~20 µg fusion protein in 13% acetic acid/6 M guanidine·HCl.

Incubate all samples at 37°C.

2. At 0, 24, 48, and 72 hr, remove a 5-µg aliquot of each reaction mixture and lyophilize to dryness.

*The 0 time point can serve as the negative control.*

3. Resuspend the hydrolyzed protein in 20 µl of 1× SDS sample buffer and neutralize by gradual addition of 0.1 M Tris base until the sample turns from yellow to blue. Analyze samples on a tricine SDS-polyacrylamide gel for extent of digestion.
4. Choose the mildest condition and shortest incubation time that give the desired extent of cleavage. Scale up to larger amounts of fusion protein accordingly.

*There is a great deal of variation in the susceptibility of Asp-Pro bonds to cleavage. Some Asp-Pro bonds cleave readily under mild conditions, whereas others are resistant to cleavage and require incubation in stronger acid conditions and/or strong denaturants to attain hydrolysis. Even under strong conditions, some Asp-Pro bonds remain uncleaved and others may not be cleaved to completion, i.e., they may be cleaved in only a fraction of the proteins. However, to avoid unwanted denaturation or modification of the protein of interest, it is important to determine the mildest conditions that give the desired degree of cleavage.*

## REAGENTS AND SOLUTIONS

Use deionized, distilled water in all recipes and protocol steps. For common stock solutions, see APPENDIX 2; for suppliers, see APPENDIX 4.

### *Hydroxylamine cleavage solution, 2×*

4 M hydroxylamine  
0.4 M CHES buffer  
Adjust pH to 9.5 with NaOH  
Prepare fresh

### *Thrombin cleavage buffer*

50 mM Tris·Cl, pH 7.5  
150 mM NaCl  
2.5 mM CaCl<sub>2</sub>  
Store indefinitely at -20°C

## COMMENTARY

### **Background Information**

The use of fusion proteins in *Escherichia coli* for production of proteins from other organisms is becoming increasingly popular. The principal advantages of fusion proteins include high expression levels, ease of purification, and ease of detection with biochemical or immunological reagents. However, early protein fusion methods fused the target protein to the carboxy-terminus of *E. coli*  $\beta$ -galactosidase; such proteins are usually insoluble, have restricted usefulness (except as antigens for antibody production), and require refolding of the protein in an attempt to retain biological activity. The development of improved fusion protein expression systems that are often capable of producing properly folded and biologically active proteins in *E. coli*, such as the MBP system (UNIT 16.6), the GST system (UNIT 16.7), and the Trx system (UNIT 16.8), has increased the need for suitable methods of separating the protein of interest from the so-called carrier protein. Such separation is desirable only after the carrier domain has been exploited for its particular attributes—e.g, to facilitate specific purification or detection, or to enhance stability or solubility. Subsequent site-specific cleavage of the carrier domain from the correctly folded protein of interest then allows evaluation of the biological activity of the protein without potential interference from a covalently-attached fusion partner.

Over the years, many different enzymatic and chemical methods for site-specific cleavage of polypeptides have been developed (Gross, 1967; Spande et al., 1970; Maroux et al., 1971; Landon, 1977; Nagai and Thøgersen, 1984; Chang, 1985; Szoka et al., 1986; Smith and Johnson, 1988; Gearing, et al., 1989; Ham-

mond et al., 1991). The choice of cleavage reagents for those expression vectors obtained from molecular biology suppliers that are used “off the shelf” will usually be dictated by the recognition sequences that lie at their respective fusion junctions. For example, MBP vectors (UNIT 16.6; Maina et al., 1988) are designed for factor Xa cleavage, GST vectors (UNIT 16.7) offer a choice of factor Xa, thrombin, or acid cleavage, and the Trx vector (UNIT 16.8; LaVallie et al., 1993a) utilizes enterokinase for cleavage. However, it is important to remember that these vectors, or any other fusion protein expression vector, can be manipulated by the user to include junction amino acids that will allow enzymatic or chemical hydrolysis with other cleavage reagents.

### **Critical Parameters and Troubleshooting**

The cleavage methods described in this unit have been chosen based upon their specificity, efficiency, and reagent availability. Ultimately, the choice of cleavage reagent will depend upon many factors. First of all, the primary sequence of the protein of interest must be scrutinized to identify sequences that will be susceptible to the cleavage reagents in question. Because of the highly restricted specificity in the case of the proteases described in the preceding protocols, the occurrence of such additional sites is unlikely. However, the use of chemical cleavage methods or less specific proteases such as trypsin (Lys↓ or Arg↓) requires careful consideration of the composition of the protein of interest to avoid unwanted fragmentation of the product. Secondly, the physical characteristics of the fusion protein are an important consideration in choosing an

appropriate cleavage method. Fusion proteins that are insoluble generally require a chemical cleavage method that allows incubation in the presence of protein denaturants such as guanidine-HCl or urea followed by proper refolding. Conversely, soluble fusion proteins should be cleaved under conditions where denaturation is minimized to preserve their structure and/or biological activity. In addition, some cleavage methods require incubation at pH extremes, which may result in modifications to some of the side chains or aggregation and precipitation of the protein and may ultimately be deleterious to the usefulness of the cleaved product.

When the fusion protein is produced in a soluble fashion, enzymatic cleavage protocols are preferred for many reasons. These reactions are carried out under mild conditions of neutral pH, low ionic strength, and moderate temperature (25° to 37°C). Such conditions approximate physiological environments and typically should be least harmful to the integrity of the protein. The high degree of specificity exhibited by these proteases ensures a low probability of unwanted cleavage elsewhere in the protein of interest. Finally, the extent of enzymatic cleavage typically can be altered by modulating parameters such as amount of enzyme, substrate concentration, and length of incubation.

The use of proteases sometimes causes problems, however. The most common problem is unwanted secondary proteolysis or degradation of the fusion protein by contaminating proteolytic activities in the cleavage reaction. Degradation may be caused by *E. coli* proteases that have not been purified away from the fusion protein prior to cleavage. Such contaminants can often be alleviated by additional purification prior to enzymatic digestion. Alternatively, the unwanted proteolytic activity may result from a contaminant in the enzyme preparation itself. These enzymes are serine proteases that have been purified from natural sources, so it is probable that they are contaminated with other proteases that copurify in trace amounts. For example, even highly purified enterokinase from bovine intestine contains trace amounts of tryptic and chymotryptic activity that can cause minor secondary proteolysis of thioredoxin fusion proteins (LaVallie et al., 1993a). This degradation can be reduced by omitting Ca<sup>++</sup> ions from the digestion and using EDTA to chelate residual Ca<sup>++</sup>. The best solution to this problem, however, is to use a recombinant source of enzyme produced in cell

culture; such enzymes are free of contaminating proteases found in intestinal preparations (LaVallie et al., 1993b and unpub. observ.).

Another potential problem that has been observed with some enzymatic cleavages is cleavage at sites other than the anticipated peptide bonds. This has been reported for factor Xa (Nagai and Thøgersen, 1987; Lauritzen et al., 1991) and thrombin (Chang, 1985); enterokinase has been observed to cleave at subsites that resemble the (Asp)<sub>4</sub>-Lys recognition sequence when the substrate is denatured or otherwise improperly folded (Light et al., 1980, E. LaVallie and L. Racie, unpub. observ.). Almost always, this relaxed site specificity can be minimized by decreasing the enzyme/substrate ratio and/or the time of incubation. There are also more exotic strategies; for example, reversible acylation of the fusion protein has been used to eliminate nonspecific cleavage by factor Xa (Wearne, 1990).

Although it is less desirable than enzymatic digestion in most circumstances, chemical cleavage of fusion proteins is sometimes necessary and may be advantageous in certain applications. This is in spite of the significant disadvantages. First, chemical cleavage procedures almost universally employ harsh conditions, such as pH extremes or high temperatures, that can denature the fusion protein and/or modify amino acid side chains (e.g., deamidation of Asn residues and oxidation of Met residues). Second, cleavage specificity tends to be limited to single amino acids or, at most, dipeptide sequences, greatly decreasing the utility of chemical reagents in site-specific cleavage of large polypeptide substrates. Even this low degree of specificity is not absolute, and low levels of side reactions at alternate sites have been noted for hydroxylamine (Bornstein and Balian, 1970; Steinman et al., 1974) and cyanogen bromide (Langley and Smith, 1971). Even acidic cleavage of Asp-Pro bonds is sometimes accompanied by nonspecific peptide bond hydrolysis when incubation is prolonged (Landon, 1977). Third, using chemical cleavage reagents involves the danger of working with hazardous compounds such as cyanogen bromide and hydroxylamine. Extreme care must be used in the storage, use, and disposal of these reagents. Material Safety Data Sheets (MSDSs) should be obtained from the manufacturer for any of these compounds and should be read carefully.

In spite of these shortcomings, however, specific chemical hydrolysis of junction peptide bonds in fusion proteins is preferred for

some applications. For instance, fusion proteins that are produced in an insoluble form cannot be cleaved enzymatically unless they have been solubilized and refolded, but site-specific cleavage of the protein domains often can be accomplished using chemical hydrolysis in the presence of strong chaotropic agents such as guanidine-HCl (Landon, 1977; Szoka et al., 1986; Villa et al., 1989). Chemical cleavages are also useful when a soluble fusion protein is refractory to cleavage under nondenaturing conditions using either enzymatic or chemical cleavage methods. Other advantages of chemical cleavage reagents are economy, purity, and wide availability.

### Anticipated Results

Enzymatic digestion of fusion proteins is sensitive to many different parameters such as temperature, pH, ionic strength, buffer composition, substrate concentration, enzyme concentration, and length of incubation. Optimum parameters must be determined empirically for each fusion protein. However, if the fusion protein is of adequate purity and the cleavage site is accessible, in most cases the standard conditions described in the protocols will give satisfactory cleavage.

Chemical cleavages are much more forgiving of small variations in reaction conditions, and cleavage should be attainable using the reaction conditions given. However, the extent of protein modifications caused by these general reaction conditions may often be significant to the ultimate usefulness of the cleaved protein. Reaction parameters may be adjusted as described to minimize any modifications or secondary cleavages that may occur.

With any of these methods, complete digestion of the fusion protein is often difficult to attain, and cleavage efficiencies of 70% to 80% should be considered satisfactory.

### Time Considerations

Fusion protein cleavage can be accomplished in hours or days, depending upon the reagents used and the reaction conditions. For factor Xa, thrombin, and enterokinase, the enzyme-to-substrate ratio and substrate concentration are often chosen so the digestions are usually complete in 8 to 24 hr. By contrast, chemical cleavages are often highly variable in the amount of time necessary for total cleavage. Overnight digestion under standard conditions is common for cyanogen bromide and acid cleavages, whereas hydroxylamine cleavages are often complete in 2 to 4 hr.

### Literature Cited

- Bornstein, P. and Balian, G. 1970. The specific nonenzymatic cleavage of bovine ribonuclease with hydroxylamine. *J. Biol. Chem.* 245:4854-4856.
- Bornstein, P. and Balian, G. 1977. Cleavage at Asn-Gly bonds with hydroxylamine. *Methods Enzymol.* 47:132-145.
- Chance, R.E., Hoffman, J.A., Kroeff, E.P., Johnson, M.G., Schirmer, E.W., Bromer, W.W., Ross, M.J., and Wetzel, R. 1981. The production of human insulin using recombinant DNA technology and a new chain combination procedure. *In* Peptides: Synthesis-Structure-Function (D.H. Rich and E. Gross, eds.), pp. 721-728. Pierce Chemical, Rockford, Ill.
- Chang, J.-Y. 1985. Thrombin specificity. *Eur. J. Biochem.* 151:217-224.
- Gearing, D.P., Nicola, N.A., Metcalf, D., Foote, S., Willson, T.A., Gough, N.M., and Williams, R.L. 1989. Production of leukemia factor in *Escherichia coli* by a novel procedure and its use in maintaining embryonic stem cells in culture. *BioTechnology* 7:1157-1161.
- Gross, E. 1967. The cyanogen bromide reaction. *Methods Enzymol.* 11:238-255.
- Hammond, P.M., Atkinson, T., Sherwood, R.F., and Scawen, M.D. 1991. Manufacturing new-generation proteins. Part I: The technology. *BioPharm.* 4:16-23.
- Itakura, K., Hirose, T., Crea, R., Riggs, A.D., Heyneker, H.L., Bolivar, F., and Boyer, H.W. 1977. Expression in *Escherichia coli* of a chemically synthesized gene for the hormone somatostatin. *Science* 198:1056-1063.
- Langley, T.J. and Smith, E.L. 1971. Sequence of bovine liver glutamate dehydrogenase. IV. Cyanogen bromide peptides. *J. Biol. Chem.* 246:3789-3801.
- Landon, M. 1977. Cleavage at aspartyl-prolyl bonds. *Methods Enzymol.* 47(E):145-149.
- Lauritzen, C., Tüchsen, E., Hansen, P.E., and Skovgaard, O. 1991. BPTI and N-terminal extended analogues generated by Factor Xa cleavage and cathepsin C trimming of a fusion protein expressed in *Escherichia coli*. *Prot. Expr. Purif.* 2:372-378.
- LaVallie, E.R., DiBlasio, E.A., Kovacic, S., Grant, K.L., Schendel, P.F., and McCoy, J.M. 1993a. A thioredoxin gene fusion system that circumvents inclusion body formation in the *E. coli* cytoplasm. *BioTechnology* 11:187-193.
- LaVallie, E.R., Rehemtulla, A., Racie, L.A., DiBlasio, E.A., Ferez, C., Grant, K.L., Light, A., and McCoy, J.M. 1993b. Cloning and functional expression of a cDNA encoding the catalytic subunit of bovine enterokinase. *J. Biol. Chem.* 268:23311-23317.
- Light, A., Savithri, H. S., and Liepnieks, J.J. 1980. Specificity of bovine enterokinase toward protein substrates. *Anal. Biochem.* 106:199-206.

- Maina, C.V., Riggs, P.D., Grandea, A.G., Slatko, B.E., Moran, L.S., Tagliamonte, J.A., McReynolds, L.A., and Guan, C. 1988. An *Escherichia coli* vector to express and purify foreign proteins by fusion to and separation from maltose-binding protein. *Gene* 74:365-373.
- Maroux, S., Baratti, J., and Desnuelle, P. 1971. Purification and specificity of porcine enterokinase. *J. Biol. Chem.* 246:5031-5039.
- Nagai, K. and Thøgersen, H. C. 1984. Generation of  $\beta$ -globin by sequence-specific proteolysis of a hybrid protein in *Escherichia coli*. *Nature* 309:810-812.
- Nagai, K. and Thøgersen, H. C. 1987. Synthesis and sequence-specific proteolysis of hybrid proteins produced in *Escherichia coli*. *Methods Enzymol.* 153:461-481.
- Smith, D.B. and Johnson, K.S. 1988. Single-step purification of polypeptides expressed in *Escherichia coli* as fusions with glutathione S-transferase. *Gene* 67:31-40.
- Spande, T.F., Witkop, B., Degani, Y., and Patchornik, A. 1970. Selective cleavage and modification of peptides and proteins. *Adv. Prot. Chem.* 24:97-260.
- Steinman, H.M., Naik, V.R., Abernethy, J.L., and Hill, R.L. 1974. Bovine erythrocyte superoxide dismutase: Complete amino acid sequence. *J. Biol. Chem.* 249:7326-7338.
- Szoka, P.R., Schreiber, A.B., Chan, H., and Murthy, J. 1986. A general method for retrieving components of a genetically engineered fusion protein. *DNA* 5:11-20.
- Villa, S., DeFazio, G., and Canosi, U. 1989. Cyanogen bromide cleavage at methionine residues of polypeptides containing disulfide bonds. *Anal. Biochem.* 177:161-164.
- Wearne, S.J. 1990. Factor Xa cleavage of fusion proteins: Elimination of nonspecific cleavage by reversible acylation. *FEBS Lett.* 263:23-26.

---

Contributed by Edward R. LaVallie  
and John M. McCoy  
Genetics Institute  
Cambridge, Massachusetts

Donald B. Smith (thrombin cleavage)  
University of Edinburgh  
Edinburgh, Scotland

Paul Riggs (denaturing fusion proteins)  
New England Biolabs  
Beverly, Massachusetts

# Expression and Purification of *lacZ* and *trpE* Fusion Proteins

## BASIC PROTOCOL

Fusion proteins are commonly used as a source of antigen for producing antibodies and in many cases can be useful for biochemical analyses. This unit describes how to express fusion proteins and prepare extracts for both applications.

Two widely used expression systems for producing large amounts of proteins in *E. coli* are presented. One system expresses *lacZ* fusions using the pUR series of vectors (UNIT 1.5; Rütger and Müller-Hill, 1983) and the other expresses *trpE* fusions using the pATH vectors (Koerner et al., 1990). The gene of interest is first subcloned into either a pUR or pATH vector in the correct reading frame. The correct transformant is selected, grown, and then induced with either IPTG or IAA. The method for preparing extracts—i.e., sonication of cells in the presence of protease inhibitors—is suitable for both types of fusion proteins, as well as for other types of proteins overexpressed in *E. coli*. The extracts are checked for the presence of fusion protein on an SDS-polyacrylamide gel.

### Materials

- pUR (UNIT 1.5) or pATH (GenBank file name M32985) vectors
- E. coli* C600, HB101, RR1 or equivalent (Table 1.4.5)
- LB plates and medium containing 50 µg/ml ampicillin (UNIT 1.1)
- 100 mM IPTG (store at -20°C)
- M9 plates and medium containing 50 µg/ml ampicillin, 0.5% Casamino acids, 10 µg/ml thiamine, and with/without 20 µg/ml tryptophan (supplemented M9; UNIT 1.1)
- 2.5 mg/ml indoleacrylic acid (IAA) in 95% ethanol (store at -20°C)
- Phosphate-buffered saline (PBS; APPENDIX 2), ice-cold
- HEMGN buffer, ice-cold
- 50 mg/ml lysozyme in 0.25 M Tris·Cl, pH 8.0 (store at -20°C)
- HEMGN buffer/8 M guanidine·HCl (prepare 100 ml and store at 4°C)
- HEMGN buffer/1 M guanidine·HCl (prepare 500 ml and store at 4°C)
- Sorvall RC-5B centrifuge with GSA rotor (or equivalent) and 200-ml bottles
- Sorvall Omnispin clinical centrifuge (or equivalent) and 15-ml conical tubes
- Sonicator with a microtip
- Sorvall SS-34 rotor (or equivalent) and 50-ml tubes
- Ultracentrifuge with Beckman 60Ti rotor (or equivalent) and tubes
- Dialysis tubing, MWCO 12,000 to 14,000 (APPENDIX 3)
- Additional reagents and equipment for subcloning of DNA fragments (UNITS 1.4 & 3.16), transformation of competent *E. coli* cells (UNIT 1.8), quantitation of proteins by the Bradford method (UNIT 10.1), and SDS-PAGE (UNIT 10.2)

### Subclone, grow, and induce cells

To express *lacZ* fusion proteins using pUR vectors:

- 1a. Subclone gene of interest into a pUR vector in the correct reading frame, transform competent *E. coli* cells, and select transformants on LB/ampicillin plates.
 

*E. coli* C600, HB101, and RR1 (Bolivar et al., 1977) have been used successfully as hosts for pUR expression vectors.
- 2a. Inoculate 2 to 5 ml LB/ampicillin medium with a single colony containing the expression vector. Grow overnight at 37°C with shaking.
- 3a. Add 1 ml of the overnight culture to 400 ml LB/ampicillin medium in a 2-liter flask.

Grow at 37°C with vigorous shaking until OD<sub>600</sub> reaches 0.5.

- 4a. Add 1.6 ml of 100 mM IPTG (0.4 mM final). Grow cells an additional 2 hr.

*IPTG is a nonmetabolizable analog of lactose, the natural inducer of the lac promoter.*

*To express trpE fusion proteins using pATH vectors:*

- 1b. Subclone gene of interest into a pATH vector in the correct reading frame, transform competent *E. coli* cells, and select transformants on supplemented M9/tryptophan plates.

- 2b. Inoculate 2 to 5 ml supplemented M9/tryptophan medium with a single colony containing the expression vector. Grow overnight at 37°C with shaking.

*E. coli RRI (Bolivar et al., 1977) has been used successfully for expressing trpE fusions; C600 and HB101 have also been used.*

*Inclusion of tryptophan in the medium represses expression of the trp operon. If fusion protein production is toxic for the host cell, repression of expression will promote maintenance of the plasmid in cells prior to induction.*

- 3b. Add 1 ml of the overnight culture to 400 ml supplemented M9 medium *without* tryptophan. Grow at 37°C with vigorous shaking until OD<sub>600</sub> reaches 0.5.

- 4b. Add 1.6 ml of 2.5 mg/ml IAA (10 µg/ml final). Grow an additional 2 hr.

*Growth of cells in medium without tryptophan induces expression of the trp operon. The addition of IAA to the medium further induces expression (Morse et al., 1969). IAA is an analog of the co-repressor tryptophan and competes with tryptophan for binding to trp repressor protein. The IAA-repressor complex is unable to bind to the trp operator and repress transcription, thereby allowing high levels of expression (Joachimiak et al., 1983).*

#### **Prepare protein extracts**

Perform all steps on ice or at 4°C.

5. Split the cell culture into two 200-ml centrifuge bottles. Harvest cells by centrifugation for 10 min in a Sorvall RC-5B using a GSA rotor at 5000 rpm (4000 × g) and discard supernatant.
6. Resuspend each pellet in 5 ml PBS by pipetting up and down. Transfer each to a 15-ml conical centrifuge tube.
7. Centrifuge 10 min in a Sorvall Omnispin clinical centrifuge at 3500 rpm (3000 × g) and discard supernatant.
8. Resuspend cells in 2 ml HEMGN buffer with protease inhibitors. Add 20 µl of 50 mg/ml lysozyme (0.5 mg/ml final). Incubate 15 to 30 min on ice.
9. Disrupt the cells by sonicating two times for 15 sec each using a microtip, placing the sample on ice between rounds of sonication. Pool the lysate into one 50-ml centrifuge tube.

*Hold the tube containing the sample so the tip of the sonicator probe is at the surface of the solution. Adjust the output level of the sonicator to the minimum setting required to achieve vigorous churning of the solution without creating foam.*

*Alternatively, a cup sonicator may be used. The advantage is that it is easier to keep the extract cold during sonication by filling the cup with ice water. The major disadvantage is that DNA is not as completely sheared, resulting in a lysate that is more viscous, thereby making it more difficult to get good separation between the soluble and insoluble fractions during subsequent centrifugation. Sonicate two times for 30 sec each if using a cup sonicator.*

10. Centrifuge cell lysate 15 min in a Sorvall SS-34 rotor at 15,000 rpm ( $27,000 \times g$ ).
11. Pour off the supernatant and save (check for the presence of the fusion protein and its biological activity in step 17). Save the pellet, which usually contains almost all of the induced protein in an insoluble form. To prepare soluble protein, proceed to the next step.

*The insoluble material from this step can be used for purification of the fusion protein by gel electrophoresis.*

#### **Solubilize the fusion protein**

12. Resuspend the pellet in 2 ml HEMGN buffer with protease inhibitors.  
*The pellet is usually very viscous and can be difficult to resuspend. Scrape the pellet off the side of the tube using a pipettor and pipet up and down a few times. Resuspension of the pellet can be aided by further sonication.*
13. Add 2 ml HEMGN buffer/8 M guanidine-HCl (4 M final guanidine). Incubate with gentle shaking 30 min at 4°C.
14. Centrifuge 30 min in a precooled ultracentrifuge using a Beckman 60Ti rotor at 35,000 rpm ( $87,000 \times g$ ).
15. Transfer the supernatant to dialysis tubing and dialyze in three steps, each  $\geq 3$  hr to overnight: first, against 500 ml HEMGN buffer/1 M guanidine-HCl, and then twice against 1 liter HEMGN buffer excluding guanidine.

*Only the protease inhibitors PMSF and sodium meta-bisulfite are necessary in the dialysis buffer (see reagents and solutions); the others are relatively expensive and have been safely omitted at this step. During dialysis about half of the protein in the extract will come out of solution as the guanidine is removed, resulting in the formation of a large amount of white precipitate.*

16. Transfer all material in the dialysis bag to a centrifuge tube and centrifuge 5 min in an SS-34 rotor at 10,000 rpm ( $12,000 \times g$ ) to remove insoluble material. Save the supernatant (~4 ml), which should be a clear, colorless solution with a protein concentration of ~1 mg/ml. (The fusion protein typically constitutes between 1% and 10% of the total protein.) Save the insoluble pellet, which usually contains most of the fusion protein and can be used for gel purifying the protein.

*This pellet fraction usually contains a higher percentage of the fusion protein than the first insoluble fraction of the lysate (from step 11).*

17. Determine the protein concentration of the supernatant and pellet from the cell lysate (steps 11 and 12) and of the final supernatant and pellet after guanidine extraction (step 16) by the Bradford method. Check the results of the induction by SDS-PAGE, loading 5 to 10  $\mu$ g of protein per lane.

*For analysis of fusion protein production, it is useful to compare extracts containing the fusion protein with control extracts prepared from uninduced cells or from cells containing the expression vector with no insert. The molecular weight of the  $\beta$ -gal protein is 116 kDa, and the trpE protein is 37 kDa. The molecular weight of the fusion protein can be predicted from the length of the open reading frame ligated to the vector sequences.*

## REAGENTS AND SOLUTIONS

### *HEMGN buffer*

100 mM KCl  
25 mM HEPES, pH 7.6  
0.1 mM EDTA, pH 8.0  
12.5 mM MgCl<sub>2</sub>  
10% glycerol  
0.1% Nonidet P-40

Prepare 2 liters of the above solution. For resuspending the cells (step 8) and resuspending the pellet (step 12), take 10 ml and add 10  $\mu$ l of each of the following just before using (save the remainder of the 2 liters for dialysis):

1 M dithiothreitol (DTT; 1 mM final)  
2 mg/ml aprotinin (2  $\mu$ g/ml final)  
1 mg/ml leupeptin (1  $\mu$ g/ml final)  
1 mg/ml pepstatin in methanol (1  $\mu$ g/ml final)  
100 mM phenylmethylsulfonyl fluoride (PMSF) in ethanol (0.1 mM final)  
100 mM sodium *meta*-bisulfite (0.1 mM final)

*The last five ingredients are protease inhibitors. Solutions of DTT, aprotinin, leupeptin, and pepstatin should be stored at -20°C. PMSF solution should be stored at 4°C. Sodium meta-bisulfite should be made fresh and stored on ice during use.*

*For dialysis, only PMSF and sodium meta-bisulfite are necessary for protease inhibition (see annotation to step 15). DTT should be included in all the dialysis buffers.*

## COMMENTARY

### Background Information

The production of fusion proteins in *E. coli* has become a widely used technique among molecular biologists. The principle advantages of this strategy for overproducing proteins are the relative ease of constructing the appropriate expression vector and the large amounts of protein that can be produced. A potential disadvantage of fusion proteins is that they are usually predominantly present in the insoluble fraction of the cell lysate. However, the insolubility of fusion proteins is actually beneficial for their most common application, producing protein for use as an antigen for generating antibodies, because the insolubility of the protein can be used as a significant purification step prior to final purification by preparative-scale SDS-PAGE (*UNIT 10.5*; Rio et al., 1986; Spindler et al., 1984). In addition, insolubility of fusion proteins may protect them from degradation by host cells.

In many cases, fusion proteins have also been used to study the biochemical properties of the induced protein. For example, *lacZ* fusions have been used to study the DNA binding activities of several proteins (Johnson and Herskowitz, 1985; Desplan et al., 1985; Kadonaga et al., 1987), and *trpE*

fusions have been used to characterize the properties of reverse transcriptase (Tanese et al., 1985) and a protein-tyrosine kinase (Sadowski et al., 1986).

An advantage of using fusion proteins for biochemical studies is that the  $\beta$ -gal or *trpE* moiety can be used as a means of identifying the protein. Antibodies directed against the  $\beta$ -gal or *trpE* protein can be used for affinity purification of the protein or to follow the protein during chromatographic fractionation (Rüther and Müller-Hill, 1983; Johnson and Herskowitz, 1985). Of course, a potential problem in using fusion proteins for biochemical analyses is that the properties of the native protein may be significantly altered because of inclusion of the foreign residues encoded by *trpE* or *lacZ*. Therefore, if the major goal is to purify the protein to study its enzymatic or other biochemical activities, a different type of expression vector containing little or no coding sequence downstream of the translation start site might be more suitable (*UNITS 16.2 & 16.3*).

### Critical Parameters and Troubleshooting

Typically, fusion proteins are expressed at

a very high level in the induced cell using the methods described in this protocol. However, if expression of the expected product is low, it can sometimes be attributed to extreme toxicity caused by the induced protein or by protein instability (or both). One approach that is usually successful in overcoming the toxicity problem is to keep the cell density low prior to induction. If a small amount of fusion protein production kills the cells, the cells that are making protein productively before induction will be lost during growth of an overnight culture, and the culture will be overtaken by cells that have lost the plasmid or by cells containing mutations that prevent expression of the protein. To circumvent this problem, the amount of ampicillin in the medium can be increased (up to 200  $\mu\text{g/ml}$ ), and an overnight culture should not be used to inoculate the 400-ml culture. Instead, start a 2-ml culture from a fresh plate and let it grow 2 to 3 hr until it reaches mid-log phase. Pour the small culture into 400 ml fresh medium and grow to an  $\text{OD}_{600}$  of 0.5 (this usually takes 4 to 5 hr).

Proteolysis sometimes occurs in fusion proteins at or near the junction of the  $\beta$ -gal or *trpE* sequences and the heterologous sequences. Most commonly, proteolysis occurs within the cell after induction. This can be tested by checking the amounts of full-length protein and breakdown products at various times after induction. Whole cells can be lysed by boiling in 1 $\times$  SDS sample buffer and then loaded onto an SDS-polyacrylamide gel (a sample prepared in this way is very viscous and difficult to load on a gel; the viscosity can be reduced by sonication). Shorter induction times may increase the ratio of full-length protein to breakdown products, although the total amount of protein will be lower.

Alternatively, proteolysis can occur during preparation of the extract. To check this, compare the relative amounts of full-length protein and truncated versions from various stages in making the extract with the state of the protein immediately after harvesting the cells. If a significant amount of proteolysis occurs during preparation of the extract, try more or different kinds of protease inhibitors (see the Boehringer Mannheim catalog for the different types of protease inhibitors). The use of protease-deficient mutants of *E. coli* might also be useful (Buell et al., 1985).

Other potential problems are complete insolubility of the fusion protein even after guanidine treatment or loss of biochemical

activity due to the guanidine denaturation. The guanidine denaturation/renaturation method described here works quite well for most proteins. However, each protein has some unique characteristics and this method cannot be expected to be optimal in every case. For both problems, one thing to try is to use urea as a denaturant rather than guanidine. Although guanidine and urea denature proteins by a similar mechanism (forming hydrogen bonds with amino acid residues, leading to disruption of the secondary and tertiary structure of the protein), some proteins may respond differently to the two denaturants. The insoluble fraction of the lysate can be resuspended in urea at concentrations up to 8 M, then dialyzed in steps to gradually reduce the urea concentration. In some cases, over-expressed proteins can be solubilized without any denaturant by extraction with high salt (Johnson and Herskowitz, 1985; Gross et al., 1976). If the protein cannot be solubilized or recovered with any activity, try expressing the protein in a different type of construct. Smaller proteins might be more stable or more soluble expressed from other constructs while retaining the domains required for biological activity (Tanese et al., 1985; Desplan et al., 1985). Other approaches that may result in improved solubility are to shorten the time of induction or to perform the induction at a lower temperature. In some cases the solubility of the expressed protein has been increased by inducing for 30 min at 30°C.

### Anticipated Results

A 400-ml culture of *E. coli* will yield 15 mg to 20 mg of total protein. About two-thirds of the total protein will be in the soluble fraction of the lysate, and one-third in the insoluble fraction (step 11). The induced protein usually represents ~1% of the soluble protein and 10% to 20% of the insoluble protein. Therefore, a typical yield from a 400-ml culture is between 0.5 mg and 1 mg of induced protein. The guanidine denaturation/renaturation procedure usually solubilizes half of the protein in the pellet, and, on average, the fusion protein is ~5% to 10% of the total in the guanidine-extracted supernatant. The material that precipitates during removal of guanidine by dialysis is ~25% to 50% induced protein.

### Time Considerations

It takes 2 to 3 hr to grow a 400-ml culture to an  $\text{OD}_{600}$  of 0.5 starting with an overnight

culture. The cells are usually grown an additional 2 hr after induction. Preparation of the protein extract requires ~3 hr to reach the first dialysis step which can then go 3 hr to overnight. Analysis of the protein extract takes 1 to 2 days.

### Literature Cited

- Bolivar, F. Rodriguez, R.L., Greene, T.J., Betlach, M.C., Heyneker, H.L., Boyer, H.W. 1977. Construction and characterization of new cloning vehicles. II. A multipurpose cloning system. *Gene* 2:95-113.
- Buell, G., Schulz, M.F., Selzer, G., Chollet, A., Movva, N.R., Semon, D., Escanez, S., and Kawishima, E. 1985. Optimizing the expression in *E. coli* of a synthetic gene encoding somatomedin-C (IGF-I). *Nucl. Acids Res.* 13:1923-1938.
- Desplan, C., Theis, J., and O'Farrell, P.H. 1985. The *Drosophila* developmental control gene, engrailed, encodes a sequence-specific DNA binding activity. *Nature (London)* 318:2513-2522.
- Gross, C., Engbaek, F., Flammang, T., and Burgess, R. 1976. Rapid micromethod for the purification of *Escherichia coli* ribonucleic acid polymerase and the preparation of bacterial extracts active in ribonucleic acid synthesis. *J. Bacteriol.* 128:382-389.
- Joachimiak, A., Schevitz, R.W., Kelley, R.L., Yanofsky, C., and Sigler, P.B. 1983. Functional inferences from crystals of *Escherichia coli* *trp* repressor. *J. Biol. Chem.* 258:12641-12643.
- Johnson, A.D. and Herskowitz, I. 1985. A repressor (MAT $\alpha$ 2 product) and its operator control expression of a set of cell type specific genes in yeast. *Cell* 42:237-247.
- Kadonaga, J.T., Carner, K.R., Masiarz, F.R., and Tjian, R. 1987. Isolation of cDNA encoding transcription factor Sp1 and functional analysis of the DNA binding domain. *Cell* 51:1079-1090.
- Koerner, T.J., Hill, J.E., Myers, A.M., and Tzagoloff, A. 1990. High-expression vectors with multiple

cloning sites for construction of *trpE*-fusion genes: pATH vectors. *Methods Enzymol.* In press.

- Morse, D.E., Mosteller, R.D., Baker, R.F., and Yanofsky, C. 1969. Direction of in vivo degradation of tryptophan messenger RNA—a correction. *Nature (London)* 223:40-43.
- Rio, D.C., Laski, F.A., and Rubin, G.M. 1986. Identification and immunological analysis of biologically active *Drosophila* P element transposase. *Cell* 44:21-32.
- Rüther, U. and Müller-Hill, B. 1983. Easy identification of cDNA clones. *EMBO J.* 2:1791-1794.
- Sadowski, I., Stone, J.C., and Pawson, T. 1986. A noncatalytic domain conserved among cytoplasmic protein-tyrosine kinases modifies the kinase function and transforming activity of Fujinami Sarcoma Virus P130<sup>gag-*fp*s</sup>. *Mol. Cell. Biol.* 6:4396-4408.
- Spindler, K.R., Rossner, D.S.E., and Berk, A.J. 1984. Analysis of Adenovirus transforming proteins from early regions 1A and 1B with antisera to inducible fusion antigens produced in *Escherichia coli*. *J. Virol.* 49:132-141.
- Tanese, N., Roth, M., and Goff, S.G. 1985. Expression of enzymatically active reverse transcriptase in *Escherichia coli*. *Proc. Natl. Acad. Sci. U.S.A.* 82:4944-4948.

### Key Reference

Koerner et al., 1990. See above.

*Contains a complete description of the different *trpE* expression vectors as well as a thorough discussion of potential problems involved in maximizing expression.*

---

Contributed by Timothy Hoey  
University of California  
Berkeley, California

## Expression and Purification of Maltose-Binding Protein Fusions

The maltose-binding protein (MBP) vectors allow the expression and purification of a protein encoded by a cloned gene by fusing it to MBP, which is encoded by the *malE* gene of *Escherichia coli* (Fig. 16.6.1). This method uses the strong, inducible *tac* promoter and the *malE* translation initiation signals to give high-level expression of the cloned gene, and isolation of the fusion protein is facilitated by an affinity purification for MBP (Kellerman and Ferenci; Fig. 16.6.2).

The gene or open reading frame of interest is subcloned into one of the MBP vectors—pMAL-c2 or pMAL-p2—so the coding sequence of interest is fused in-frame to the 3' end of the *malE* gene. The vector pMAL-c2 has an exact deletion of the *malE* signal sequence which leads to cytoplasmic expression of the fusion protein. Fusion plasmids made with this vector usually give a higher yield of fusion protein than those made with pMAL-p2. The vector pMAL-p2 contains the normal signal sequence of the *malE* gene, which potentially directs the fusion protein through the cytoplasmic membrane to the periplasm. This promotes proper folding and disulfide bond formation for some proteins and allows purification from the periplasm (Hsiung et al., 1986; Lauritzen et al., 1991).

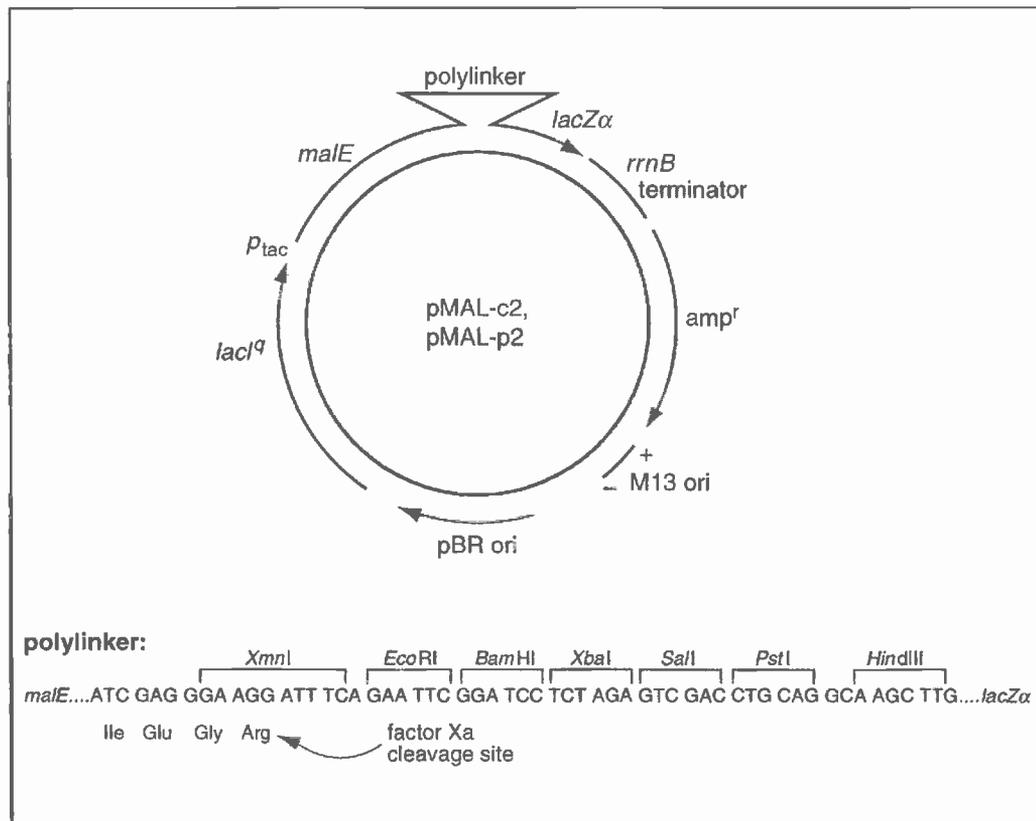

**Figure 16.6.1** pMAL vectors. The vectors contain the inducible  $p_{tac}$  promoter positioned to transcribe a *malE-lacZ* gene fusion. The *lacI* gene encodes the *lac* repressor, which turns off transcription from  $p_{tac}$  until IPTG is added. The polylinker provides several restriction endonuclease sites for inserting the gene of interest so it is fused to the *malE* gene. The *rrnB* terminators prevent transcription from  $p_{tac}$  from interfering with plasmid replication or maintenance functions. pMAL-c2 (6646 base pairs) has an exact deletion of the *malE* signal sequence. pMAL-p2 (6721 base pairs) includes the *malE* signal sequence. Arrows indicate the direction of transcription. Restriction sites indicated are unique.

The MBP vectors also include a sequence that encodes the four-amino-acid recognition site for the specific protease factor Xa. The site is placed so it can be used to separate the protein of interest from MBP after affinity purification. Factor Xa cuts after arginine in the sequence Ile-Glu(or Asp)-Gly-Arg. Depending on which restriction endonuclease site is used to insert the gene of interest, this means that few or no amino acids encoded by the vector are present on the protein of interest after cleavage by factor Xa (see UNIT 16.4B).

The basic protocol of this unit outlines subcloning the sequence encoding the protein of interest into an MBP vector, and expressing and purifying the protein from the cytoplasm. The first support protocol provides a pilot experiment for analyzing the solubility, affinity for the amylose resin, and export of a particular fusion protein. The alternate protocol gives instructions for purifying a fusion protein from the periplasm for fusions that are

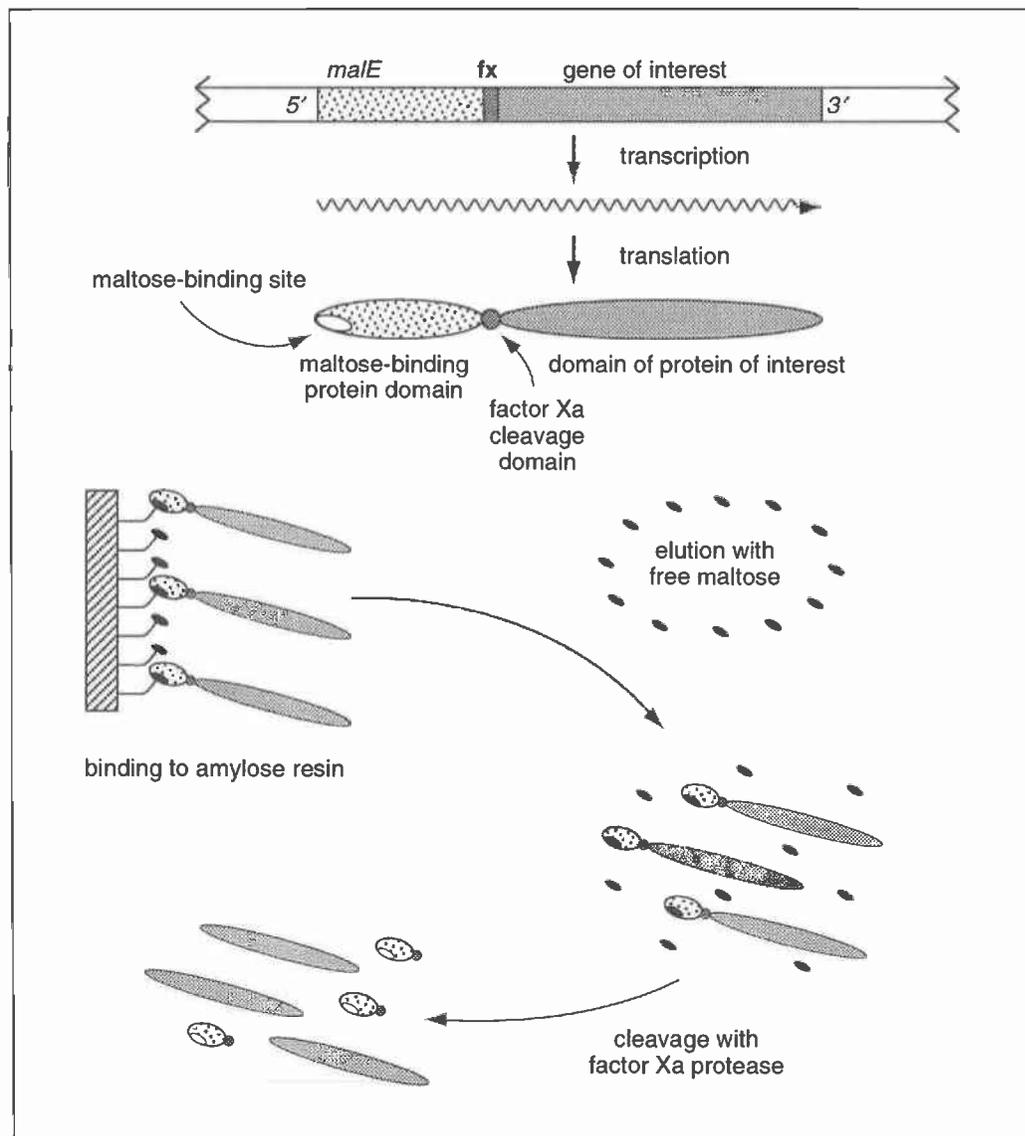

**Figure 16.6.2** Schematic representation of expression and purification of a protein using the MBP vectors. "fx" denotes the sequence coding for the recognition site of factor Xa. The gene of interest is cloned 3' to the *malE* gene and expressed, cells are lysed, and the extract is poured over a column of amylose resin. The MBP fusion protein binds to the column and the remaining proteins in the cell extract are washed through the column (Kellerman and Ferenci, 1982). The fusion protein is eluted with free maltose and then cleaved with factor Xa to separate MBP from the protein of interest. Modified from Maina et al., 1988 with permission of Elsevier Science Publishing.

made in the signal sequence vector and are exported. Methods for cleaving the purified fusion protein with factor Xa and for preparing a fusion protein for factor Xa cleavage when the cleavage site is initially blocked are provided in *UNIT 16.4B*. The second and third support protocols detail two different chromatographic methods for separating the protein of interest from MBP after factor Xa cleavage.

## **CONSTRUCTION, EXPRESSION, AND PURIFICATION OF MBP FUSION PROTEINS**

The sequence encoding the protein of interest is subcloned into an MBP vector. Cells bearing the fusion plasmid are grown, the *tac* promoter is induced with isopropyl-1-thio- $\beta$ -D-galactoside (IPTG), and the cells are harvested. A crude cell extract is prepared and passed over a column containing an agarose resin derivatized with amylose (a polysaccharide consisting of maltose subunits). The fusion protein binds to the column because of MBP's affinity for amylose, is eluted with free maltose, and is analyzed by SDS-PAGE (Fig. 16.6.2).

### **Materials**

*For recipes, see Reagents and Solutions in this unit (or cross-referenced unit); for common stock solutions, see APPENDIX 2; for suppliers, see APPENDIX 4.*

- pMAL-c2 and/or pMAL-p2 (New England Biolabs; see Fig. 16.6.1)
- Escherichia coli* TB1 (New England Biolabs) or any transformable strain of *E. coli* (see Table 1.4.5)
- LB plates and medium containing 0.2% glucose and 100  $\mu$ g/ml ampicillin (*UNIT 1.1*)
- LB plates containing 100  $\mu$ g/ml ampicillin, 0.3 mM isopropyl-1-thio- $\beta$ -D-galactoside (IPTG), and 80  $\mu$ g/ml Xgal (*UNIT 1.1*)
- 1 $\times$  and 2 $\times$  SDS sample buffer (*UNIT 10.2*)
- 0.1 M IPTG
- Column buffer, without and with 10 mM maltose
- Coomassie brilliant blue solution (*UNIT 10.1*)
- Amylose resin (New England Biolabs)
- Beckman JS-4.2 and JA-17 rotors (or equivalents)
- Sonicator
- 2.5  $\times$  10-cm column
- Centricon or Centriprep concentrator *or* stirred-cell concentrator (Amicon), *or* equivalent
- Boiling water bath
- Additional reagents and equipment for replica plating (*UNIT 1.3*), subcloning of DNA fragments (*UNITS 1.4 & 3.16*), preparing miniprep plasmid DNA (*UNIT 1.6*), restriction mapping (*UNIT 3.2*), quantitation of protein by the Bradford method (*UNIT 10.1*), and SDS-PAGE (*UNIT 10.2*)

**NOTE:** A kit containing the pMAL vectors, TB1, amylose resin, factor Xa, anti-MBP serum, MBP as a gel marker, and an MBP fusion as a factor Xa control is available from New England Biolabs.

### **Obtain and grow the fusion plasmid**

1. Subclone target gene or open reading frame into pMAL-c2 and/or pMAL-p2 so it is in the same translational reading frame as the *malE* gene of the vector (see Fig. 16.6.1). The insert should have a stop codon at the end of the coding sequence, and if the *XmnI* site is used, the first three bases of the insert should not code for a proline residue.

If an appropriate restriction site is not available at the 5' end of the gene, one must be introduced, e.g., by oligonucleotide-directed mutagenesis (UNIT 8.1), by cloning with synthetic oligonucleotides (UNIT 3.16), by PCR (UNIT 15.1), or by generating half restriction sites (UNIT 15.7).

If a stop codon is not present at the end of the open reading frame, a linker containing a stop codon can be inserted into one of the downstream polylinker sites after step 2. A proline codon immediately following the arginine codon of the factor Xa site will preclude separation of MBP from the protein of interest, as factor Xa cannot cleave the Arg-Pro bond (Nagai and Thøgersen, 1984, 1987).

2. Transform *E. coli* TB1 with the ligated vector + insert and plate on LB/glucose/ampicillin. Incubate overnight at 37°C.
3. Replica plate transformants onto an LB/glucose/ampicillin master plate and an LB/ampicillin/IPTG/Xgal indicator plate. Incubate 8 to 16 hr at 37°C. Identify transformants on the indicator plate (positive transformants are white, those with vector alone are blue). Recover clones with inserts from the corresponding spot on the master plate.

*The vectors are lethal to E. coli when  $p_{lac}$  is induced, so screening for inserts cannot be done with IPTG and Xgal in the transformation plates. For directional cloning (UNIT 3.16), the ligation efficiency is usually so high that the screen is unnecessary.*

4. Prepare miniprep DNA from candidate transformants and confirm the presence and orientation of the insert by restriction mapping.
5. Inoculate 10 ml LB/glucose/ampicillin medium with a single colony containing the fusion plasmid. Grow overnight at 37°C with shaking.
6. Inoculate 1 liter LB/glucose/ampicillin medium with 10 ml overnight culture (a 1:100 dilution). Grow at 37°C, shaking, to  $2 \times 10^8$  cells/ml ( $OD_{600} = 0.4$  to 0.6).
7. Remove a 1-ml sample, microcentrifuge 2 min, and discard supernatant. Resuspend cells in 50  $\mu$ l of 1 $\times$  SDS sample buffer and set aside on ice for analysis in steps 20 and 21 (uninduced cells).

#### ***Induce the promoter and harvest the cells***

8. Add 3 ml of 0.1 M IPTG (0.3 mM final) to remainder of culture. Incubate 2 hr at 37°C with good aeration.
9. Remove another 1-ml sample, microcentrifuge 2 min, and discard supernatant. Resuspend cells in 100  $\mu$ l of 1 $\times$  SDS sample buffer, and set aside on ice for analysis in steps 20 and 21 (induced cells).
10. Centrifuge remaining cells 20 min at  $4000 \times g$  (4200 rpm in a JS-4.2 rotor), 4°C, and discard supernatant.
11. Resuspend cells in 50 ml column buffer. Freeze sample at -70°C (or overnight at -20°C). Thaw in cold water.

*Freezing weakens the cells so that lysis occurs more readily. Slow freezing overnight at -20°C is more effective than quick freezing at -70°C. This step can be omitted, but doing so necessitates more sonication in step 12.*

12. Put cell suspension in a plastic or metal tube and place in an ice-water bath. Sonicate using short bursts to avoid heating the extract (if sonicator has a "pulse" mode, use a 50% duty cycle). Monitor release of protein by adding 10  $\mu$ l sonicate to 1.5 ml Coomassie brilliant blue to obtain a Bradford reaction. Check protein concentration

every 30 sec of sonication time. Continue sonication until released protein reaches a maximum (usually ~1 to 3 min of sonication time).

13. Centrifuge the sonicated cells 20 min at  $14,000 \times g$  (10,000 rpm in a JA-17 rotor), 4°C. Discard pellet.
14. Remove a 5- $\mu$ l sample of the supernatant (crude extract), add 5  $\mu$ l of 2 $\times$  SDS sample buffer, and set aside on ice for analysis in steps 20 and 21. Save the rest of the supernatant for passage over the amylose resin column in step 16.

#### ***Purify and analyze the fusion protein***

15. Pour amylose resin in a  $2.5 \times 10$ -cm column. Wash with 8 column volumes of column buffer.

*The amount of resin needed depends on the amount of fusion protein produced. The resin binds about 3 mg/ml bed volume; a column of ~15 ml should be sufficient for a yield of  $\leq 45$  mg fusion protein/liter culture. A 50-ml syringe plugged with silanized glass wool can be substituted for the column, but the glass wool should cover the bottom of the syringe (not just fill the tip) to achieve an acceptable flow rate.*

16. Dilute crude extract 1:5 with column buffer. Load at a flow rate of ~1 ml/min [ $10 \times$  (diameter of column in cm)<sup>2</sup> ml/hr].
17. Wash with 12 column volumes of column buffer.
18. Elute fusion protein with column buffer/10 mM maltose, collecting ten to twenty 3-ml fractions. Assay fractions for protein by the Bradford method or by measuring the  $A_{280}$ .

*The fractions containing the MBP fusion should have easily detectable protein. The fusion protein starts to elute after ~5 ml. Proteins that contain tyrosine and/or tryptophan residues absorb at 280 nm, so  $A_{280}$  measurements can often be used instead of the Bradford method to detect protein.*

19. Pool the protein-containing fractions. If necessary, concentrate to ~1 mg/ml in a Centricon or Centriprep concentrator or stirred-cell concentrator.
20. Remove 3  $\mu$ g eluted protein and mix with an equal volume of 2 $\times$  SDS sample buffer. Heat uninduced cells, induced cells, crude extract, and eluted protein 5 min in a boiling water bath.
21. Electrophorese on an SDS-polyacrylamide gel. Load 20  $\mu$ l uninduced and induced cell samples, all 10  $\mu$ l crude extract sample, and ~3  $\mu$ g eluted protein.

*If the fusion protein is present in the crude extract, but absent from the maltose-eluted fraction, use the following pilot experiment (first support protocol) to determine if the fusion protein is soluble and has affinity for the amylose resin.*

### **SUPPORT PROTOCOL 1**

#### **PILOT EXPERIMENT TO CHARACTERIZE THE BEHAVIOR OF AN MBP FUSION PROTEIN**

This is a small-scale experiment to determine the behavior of a particular MBP fusion protein. It can be used either as a pilot experiment or to troubleshoot the basic protocol. The protocol results in five (pMAL-c2) or seven (pMAL-p2) samples: uninduced and induced cells, a crude extract of the soluble proteins, a suspension of the insoluble material, a sample of protein that binds to the amylose resin, and (if the fusion was made with pMAL-p2) a periplasmic fraction prepared by the cold osmotic shock procedure and the cells that remain after osmotic shock.

### **Additional Materials**

For recipes, see *Reagents and Solutions* in this unit (or cross-referenced unit); for common stock solutions, see APPENDIX 2; for suppliers, see APPENDIX 4.

Cells containing fusion plasmid (basic protocol)

30 mM Tris·Cl/20% sucrose, pH 8.0

0.5 M EDTA, pH 8.0 (APPENDIX 2)

5 mM MgSO<sub>4</sub>, ice-cold

### **Grow, induce, and harvest the cells**

1. Inoculate 80 ml LB/glucose/ampicillin medium with cells containing the fusion plasmid (e.g., a 1:100 dilution from an overnight culture from step 3, basic protocol).
2. Grow at 37°C with good aeration to  $2 \times 10^8$  cells/ml ( $OD_{600} = 0.4$  to 0.6).
3. Remove a 1-ml sample, microcentrifuge 2 min, and discard supernatant. Resuspend cells in 50  $\mu$ l of 1 $\times$  SDS sample buffer and place on ice for analysis in step 12 (uninduced cells).
4. Add 0.24 ml of 0.1 mM IPTG (0.3 mM final) to remaining culture. Continue incubation 2 hr at 37°C.
5. Remove a 1-ml sample, microcentrifuge 2 min, and discard supernatant. Resuspend cells in 100  $\mu$ l of 1 $\times$  SDS sample buffer and place on ice for analysis in step 12 (induced cells).

*Take samples at 1 and 3 hr to help determine optimum expression time.*

6. Divide culture into two aliquots (samples A and B). Centrifuge 10 min at  $7000 \times g$  (7000 rpm in a JA-17 rotor), 4°C, and discard supernatant.
7. Resuspend one pellet (sample A) in 5 ml column buffer. Resuspend the other pellet (sample B) in 10 ml of 30 mM Tris·Cl/20% sucrose, pH 8.0 (8 ml for each 0.1 g cells, wet weight).

### **Prepare samples A and B**

For sample A (pMAL-c2 and pMAL-p2):

- 8a. Freeze sample in a dry ice/ethanol bath or at  $-20^\circ\text{C}$  and thaw in cold water. Put cell suspension in a plastic or metal tube, place in an ice-water bath, and sonicate using short bursts as in step 12 of the basic protocol.
- 9a. Centrifuge the cells 20 min at  $14,000 \times g$  (10,000 rpm in a JA-17 rotor), 4°C. Decant supernatant (crude extract) and save on ice for analysis in steps 11a and 12. Resuspend pellet (insoluble matter) in 5 ml column buffer and save on ice for analysis in step 12.
- 10a. Place 200  $\mu$ l amylose resin in a 1.5-ml tube and microcentrifuge briefly. Remove supernatant by aspiration and discard. Resuspend resin in 1.5 ml column buffer, then microcentrifuge briefly and discard supernatant. Repeat this wash and resuspend the resin in 200  $\mu$ l column buffer.
- 11a. Mix 100  $\mu$ l crude extract with 50  $\mu$ l amylose resin slurry. Incubate 15 min on ice. Microcentrifuge the sample 1 min, then remove supernatant and discard. Wash pellet with 1 ml column buffer, microcentrifuge 1 min, and resuspend the resin (bound protein) in 50  $\mu$ l of 1 $\times$  SDS sample buffer. Save for analysis in step 12.

*For sample B (pMAL-p2 only):*

- 8b. Add 20  $\mu$ l of 0.5 M EDTA, pH 8.0 (1 mM final) and incubate 5 to 10 min at room temperature with shaking or stirring.
- 9b. Centrifuge the cells 10 min at  $7000 \times g$  (7000 rpm in a JA-17 rotor), 4°C. Remove and discard all the supernatant.
- 10b. Resuspend pellet in 10 ml ice-cold 5 mM MgSO<sub>4</sub>. Shake or stir 10 min in an ice bath.
- 11b. Centrifuge the cells 10 min at  $14,000 \times g$  (10,000 rpm in a JA-17 rotor), 4°C. Save the supernatant (cold osmotic shock fluid). Resuspend pellet (shocked cells) in 5 ml column buffer.

#### **Analyze samples by SDS-PAGE**

12. Add 5  $\mu$ l of 2 $\times$  SDS sample buffer to 5  $\mu$ l crude extract, insoluble matter, and (for pMAL-p2) shocked cells. Add 10  $\mu$ l of 2 $\times$  SDS sample buffer to 10  $\mu$ l cold osmotic shock fluid. Heat these samples, along with the uninduced and induced cell samples and the amylose resin sample, 5 min in a boiling water bath. Microcentrifuge 2 min.
13. Load the samples on a 10% SDS-polyacrylamide gel as follows: 20  $\mu$ l uninduced cells, 20  $\mu$ l induced cells, 10  $\mu$ l crude extract, 10  $\mu$ l insoluble matter, 20  $\mu$ l bound protein, and (for pMAL-p2 fusions only) 20  $\mu$ l osmotic shock fluid and 10  $\mu$ l shocked cells. Electrophorese.

*If fusion protein is present in cold osmotic shock fluid, use the purification procedure in the following alternate protocol.*

*If desired, prepare an immunoblot (UNIT 10.8) and develop with anti-MBP serum (New England Biolabs) and, if available, serum directed against the protein of interest.*

#### **ALTERNATE PROTOCOL**

#### **PURIFICATION OF FUSION PROTEINS FROM THE PERIPLASM**

This protocol is useful if the protein of interest is exported and must be purified from the periplasm. The method includes preparation of a periplasmic fraction by cold osmotic shock followed by affinity purification as in the Basic Protocol.

#### **Additional Materials**

*For recipes, see Reagents and Solutions in this unit (or cross-referenced unit); for common stock solutions, see APPENDIX 2; for suppliers, see APPENDIX 4.*

Cells containing fusion plasmid (basic protocol)

30 mM Tris-Cl/20% (w/v) sucrose, pH 8.0

0.5 M EDTA, pH 8.0 (APPENDIX 2)

5 mM MgSO<sub>4</sub>

1 M Tris-Cl, pH 7.4 (APPENDIX 2)

Beckman JA-14 rotor (or equivalent)

1. Inoculate 1 liter LB/glucose/ampicillin medium with cells containing the fusion plasmid (e.g., a 1:100 dilution from an overnight culture from step 3, basic protocol).
2. Grow to  $2 \times 10^8$  cells/ml ( $OD_{600} = 0.4$  to  $0.6$ ).
3. Add 3 ml of 0.1 M IPTG (0.3 mM final). Incubate cells 2 hr at 37°C with good aeration.
4. Centrifuge the cells 10 min at  $7000 \times g$  (7000 rpm in a JA-14 rotor), 4°C, and discard supernatant.

5. Resuspend cells in 400 ml of 30 mM Tris·Cl/20% sucrose, pH 8.0 (80 ml for each gram of cells, wet weight). Add 0.8 ml of 0.5 M EDTA, pH 8.0 (1 mM final) and incubate 5 to 10 min at room temperature with shaking or stirring.
6. Centrifuge the cells 10 min at  $10,000 \times g$  (8000 rpm in a JA-14 rotor), 4°C. Remove all supernatant and resuspend pellet in 400 ml ice-cold 5 mM MgSO<sub>4</sub>. Shake or stir 10 min in an ice bath.
7. Centrifuge again as in step 6. Save the supernatant (cold osmotic shock fluid) and add to it 8 ml of 1 M Tris·Cl, pH 7.4.
8. Prepare amylose resin column as in step 15 of the basic protocol. Load cold osmotic shock fluid on column at a flow rate of ~1 ml/min [ $10 \times (\text{diameter of column in cm})^2$  ml/hr].
9. Recover and analyze protein fractions as in steps 17 to 21 of the basic protocol.

## PURIFYING THE CLEAVED PROTEIN BY ION EXCHANGE CHROMATOGRAPHY

**SUPPORT  
PROTOCOL 2**

After factor Xa cleavage (*UNIT 16.4B*), the protein of interest can be separated from MBP, factor Xa, and trace contaminants by Sepharose ion-exchange chromatography. Cleaved fusion protein amounts of  $\leq 25$  mg can be purified by this procedure, which can also be scaled up for larger amounts.

### *Additional Materials*

*For recipes, see Reagents and Solutions in this unit (or cross-referenced unit); for common stock solutions, see APPENDIX 2; for suppliers, see APPENDIX 4.*

Fusion protein cleaved with factor Xa (*UNIT 16.4B*)

20 mM Tris·Cl/25 mM NaCl, pH 8.0

DEAE-Sepharose or Q-Sepharose resin

20 mM Tris·Cl/500 mM NaCl, pH 8.0

1 × 10-cm column

Additional reagents and equipment for purification of proteins by conventional chromatography (*UNIT 10.10*)

1. Dialyze fusion protein cleaved with factor Xa two or three times against  $\geq 100$  vol of 20 mM Tris·Cl/25 mM NaCl, pH 8.0.
2. Wash ~6 ml Sepharose resin twice in 20 ml of 20 mM Tris·Cl/25 mM NaCl, letting resin settle and pouring off supernatant between washes.
3. Pour resin into a 1 × 10-cm column to give a bed volume of 5 ml with a 6 to 7-cm bed height. Wash with 15 ml of 20 mM Tris·Cl/25 mM NaCl.
4. Load dialyzed fusion protein onto column. Collect 2.5-ml fractions of the column flow-through.
5. Wash column with 3 to 5 column volumes of 20 mM Tris·Cl/25 mM NaCl. Continue collecting 2.5-ml fractions.
6. Start a gradient of 20 mM Tris·Cl/25 mM NaCl to 20 mM Tris·Cl/500 mM NaCl, pH 8.0. Collect 1-ml fractions.
7. Identify protein-containing fractions by the Bradford method or by measuring  $A_{280}$ .

*MBP elutes as a sharp peak at 100 to 150 mM NaCl. Factor Xa elutes at ~400 mM NaCl. The target protein may flow through the column, or it may elute during the gradient.*

**Protein  
Expression**

**16.6.8**

- Analyze relevant fractions by SDS-PAGE. Pool fractions containing the target protein free of MBP and concentrate as needed.

## PURIFYING THE CLEAVED PROTEIN BY AFFINITY CHROMATOGRAPHY

In this method, all the protein from the factor Xa cleavage reaction (UNIT 16.4B) is bound to hydroxylapatite and the maltose is washed away from the bound protein. This step is a substitute for dialysis, which is impractical for removing all traces of maltose from the MBP binding site (Silhavy et al., 1975). The protein mixture is then passed over a fresh amylose column and the MBP binds to the column, allowing the protein of interest to be collected in the flow-through. Although this protocol requires two steps, no dialysis is needed and both columns are step-eluted, so the procedure is fairly simple. It should be carried out at room temperature to avoid precipitation of the 0.5 M sodium phosphate buffer. This method does not remove factor Xa or any trace contaminants, and any MBP that has been denatured or otherwise damaged will not bind to the amylose column. The procedure is written for  $\geq 25$  mg, and can be scaled up for larger amounts.

### Additional Materials

For recipes, see *Reagents and Solutions* in this unit (or cross-referenced unit); for common stock solutions, see APPENDIX 2; for suppliers, see APPENDIX 4.

Hydroxylapatite resin  
Fusion protein cleaved with factor Xa (UNIT 16.4B)  
0.5 M sodium phosphate, pH 7.2  
1 or  $1.5 \times 10$ -cm column

Additional reagents and equipment for hydroxylapatite chromatography (UNIT 2.10)

- Swell 1 g hydroxylapatite in column buffer for 15 min. Wash resin three times in column buffer by swirling it, then letting it settle 1 min. Pour off milky supernatant.

*This washes the resin and removes the "fines" that can cause the column to flow slowly.*

- Pour hydroxylapatite into a 1 or  $1.5 \times 10$ -cm column.

*The larger-diameter column will give a faster flow rate.*

- Load fusion-protein cleaved with factor Xa onto the column. Wash column with 80 ml column buffer.

*This step removes the maltose.*

- Elute protein with 20 ml of 0.5 M sodium phosphate, pH 7.2. Collect 2-ml fractions. Assay for protein by the Bradford method or by measuring the  $A_{280}$ .

*Most of the protein usually elutes in the first 8 ml.*

- Prepare 15-ml amylose column as in step 15 of the basic protocol.

- Load hydroxylapatite-eluted protein onto the amylose column. Reapply flow-through two times. Collect final flow-through as 5-ml fractions. Wash column with 50 ml column buffer, continuing to collect 5-ml fractions. Assay for protein by the Bradford method or by measuring the  $A_{280}$ . Concentrate the protein as needed.

*Most of the protein flows through in the first 35 ml. Protein should be free of MBP and consist of target protein and factor Xa.*

## REAGENTS AND SOLUTIONS

Use deionized, distilled water in all recipes and protocol steps. For common stock solutions, see APPENDIX 2; for suppliers, see APPENDIX 4.

### Column buffer

Per liter:

20 ml 1.0 M Tris-Cl, pH 7.4 (20 mM final)

11.7 g NaCl (0.2 M final)

2.0 ml 0.5 M EDTA (1 mM final)

0.7 ml 2-ME (optional; 10 mM final)

1 ml 1 M NaN<sub>3</sub> (optional; 1 mM final)

Store ~1 month at room temperature

### Isopropyl-1-thio- $\beta$ -D-galactoside, 0.1 M

1.41 g isopropyl- $\beta$ -D-thiogalactoside (IPTG)

H<sub>2</sub>O to 50 ml

Filter sterilize and store ~1 year at 4°C

### 0.5 M sodium phosphate buffer, pH 7.2

A: 69.0 g NaH<sub>2</sub>PO<sub>4</sub>·H<sub>2</sub>O, to 1 liter with H<sub>2</sub>O

B: 134.0 g Na<sub>2</sub>HPO<sub>4</sub>·7H<sub>2</sub>O, to 1 liter with H<sub>2</sub>O

Mix 117 ml A with 383 ml B

Store indefinitely at room temperature

## COMMENTARY

### Background Information

The maltose binding protein (MBP) vectors (Fig. 16.6.1) were constructed as a way of expressing and purifying a cloned protein or peptide by fusing it to maltose-binding protein, coded for by the *malE* gene of *Escherichia coli* (Guan et al., 1988; Bedouelle and Duplay, 1988; Maina et al., 1988). The vectors have the strong, inducible *tac* promoter (Amann and Brosius, 1985) expressing the *malE* gene (with or without its signal sequence), fused to the *lacZ $\alpha$*  gene. When present, the signal peptide on pre-MBP directs fusion proteins to the periplasm. Restriction endonuclease sites between *malE* and *lacZ $\alpha$*  are available for insertion of the coding sequence of interest in a way that interrupts the *malE-lacZ $\alpha$*  fusion.

The *p<sub>tac</sub>* region of these plasmids is from pTP201 (T. Poteet, unpub. observ.; the same construction as pKK207-1, Amann & Brosius, 1985), with a fragment carrying *lacI<sup>q</sup>* (*EcoRI*-*BanI* partial-digest product, filled in with Klenow fragment) adjacent upstream from *p<sub>tac</sub>*. The *lacI<sup>q</sup>* gene codes for the *lac* repressor, which keeps expression from *p<sub>tac</sub>* low in the absence of isopropyl-1-thio- $\beta$ -D-galactoside (IPTG) induction. The *malE* region is the *HinII* (filled in) fragment of *malE* (Duplay et al., 1984). The vector backbone is from *AvaI* (filled in) to *EcoRI* (filled in) of pKK233-2 (Amann

& Brosius, 1985). This gives the vectors a pBR322-like copy number. The vectors also include the origin of DNA replication of bacteriophage M13 from the plasmid pZ150 (Zagursky and Berman, 1984), to facilitate the production of single-stranded DNA for sequencing or mutagenesis (UNIT 1.15).

Insertion of the target sequences downstream of *malE* interrupts the *malE-lacZ $\alpha$*  fusion. This allows use of the blue-to-white screen for inserts when transforming into an  $\alpha$ -complementing *E. coli* host, such as TB1 or JM107, and plating on Xgal plates (Yanisch-Perron et al., 1985; UNIT 1.4). Because the vectors are lethal to *E. coli* when *p<sub>tac</sub>* is induced, screening for inserts cannot be done with IPTG in the transformation plates. The screen can be accomplished by picking colonies with a sterile toothpick or by replica plating onto an LB/ampicillin master plate and an LB/ampicillin/IPTG/Xgal indicator plate.

### Choice of MBP vector

If little is known about the protein of interest, the best strategy is to construct fusions in both vectors and empirically determine which is best. However, some information about the protein, if available, may help guide the choice of vector. The vector lacking the signal sequence, pMAL-c2, produces a cytoplasmic fu-

sion protein and has several advantages. Most importantly, it generally gives at least a four-fold higher yield than pMAL-p2. In addition, unstable proteins are often more stable when expressed from pMAL-c2 than when expressed from pMAL-p2, suggesting that there is more protease activity in the periplasm. Moreover, cytoplasmic expression can sometimes circumvent the instability and folding problems caused by the attempt to export cytoplasmic proteins (Bedouelle and Duplay, 1988; Gentz et al., 1988).

However, there are cases where use of the signal sequence vector, pMAL-p2, may prove advantageous. Some foreign proteins cannot fold correctly when expressed in the *E. coli* cytoplasm, and are produced in an inactive or unstable form. Secretion into the periplasm has been used to promote proper folding of such proteins (Hsiung et al., 1986; Lauritzen et al., 1991). In particular, the *E. coli* cytoplasm is a reducing environment, so disulfide bonds do not usually form until the cells are lysed to make a crude extract. This may allow abnormal disulfide bonds to form (e.g., interchain rather than intrachain). *E. coli* proteins do, however, form disulfide bonds in the periplasm, and in fact an accessory protein that catalyzes this process in *E. coli* has been described (Bardwell et al., 1991). Thus, for some foreign proteins, secretion into the periplasm can provide a protein-folding pathway that more closely mimics the native environment of the protein of interest. For these reasons, pMAL-p2 may be the vector of choice for proteins that are secreted in their native host or have disulfide bonds. In addition, in spite of the lower yield of fusion protein when expressed from pMAL-p2 relative to pMAL-c2, the number of different *E. coli* proteins in the periplasm is much lower than in the cytoplasm. This makes export to the periplasm a purification step, and the number of different proteins present in trace amounts in the affinity-purified protein is probably lower for fusion proteins purified from the periplasm.

#### *Separation of the protein from MBP*

After purification of the fusion protein, the MBP domain can be separated from the protein of interest by cleavage with factor Xa protease (UNIT 16.4B; Nagai and Thøgersen, 1984, 1987). About 50% of the time, the cleavage reaction works on the native fusion protein as it is eluted from the column. The remaining 50% of the cases break down into two categories: fusion proteins that do not cut with factor Xa and

fusion proteins that are cleaved at secondary sites within the protein of interest (see Troubleshooting). Many fusion proteins that do not cut with factor Xa after elution from the amylose column can be cleaved after denaturation and removal of the denaturant (UNIT 16.4B).

Once the fusion protein has been cleaved with factor Xa, the two domains can be separated chromatographically. Sepharose chromatography has an advantage over the affinity method, because it provides for the removal of factor Xa and any other trace contaminants. For Sepharose and most other chromatography resins, there is an equivalent HPLC method that increases the resolution of this step (UNIT 10.13).

#### **Troubleshooting**

One problem that is often encountered when expressing foreign proteins in *E. coli* (including MBP fusion proteins) is that the expressed protein is unstable. In these cases, conditions for expression and crude extract preparation can be optimized in a number of ways. The time allowed for expression can be shortened to 1 hr, which usually decreases the yield by half but can lead to a higher proportion of full-length fusion protein. In addition, the stability of a particular fusion protein can show large differences among different strain backgrounds. Apparently, different laboratory strains of *E. coli* differ a good deal in the levels and types of proteases that are produced.

If the fusion protein is being expressed cytoplasmically (in pMAL-c2), the use of *E. coli* protease mutants such as *lon* and *htpR* can reduce the degree of degradation (Baker et al., 1984; I. Hall and P. Riggs, unpub. observ.). In addition, some cytoplasmically expressed proteins are stabilized by using a host deficient in the chaperonin *DnaJ* (Straus et al., 1988; Reidhaar-Olson et al., 1990). It is possible that fusions that are exported to the periplasm might be stabilized by using a *degP* mutant (Strauch and Beckwith, 1988) or a *tsp* mutant (Silber et al., 1992). These mutations also could lead to stabilization of a cytoplasmically expressed fusion protein because such proteins are exposed to periplasmic proteases upon cell lysis. Similarly, fusion proteins being prepared from either the cytoplasm or the periplasm might be stabilized by using an *ompT* mutant, which lacks an outer membrane protease that has been shown to cleave prokaryotic and eukaryotic proteins during the preparation of crude extracts (Grodberg and Dunn, 1988; Sugimura and Higashi, 1988). Often, most of the degradation of MBP fusion proteins takes place in

vivo or during harvesting the cells and preparing the crude extract; once the crude extract is made, most proteins are fairly stable. However, if a fusion protein is unstable in the crude extract, the addition of protease inhibitors could help. One reason for the EDTA in the column buffer is to chelate calcium and inhibit the activity of calcium-dependent proteases once the cells are lysed.

A second problem sometimes seen when expressing MBP fusion proteins is that high levels of fusion protein can lead to the formation of insoluble aggregates. If a fusion protein is insoluble, lowering the temperature of expression and/or the level of induction of *p<sub>lac</sub>* sometimes yields soluble fusion protein (e.g., induction with 10 to 100  $\mu$ M IPTG at  $\leq 30^\circ\text{C}$ ; Tagaki et al., 1988; Schein, 1989). Similarly, switching to a different host strain can result in large differences in the proportion of a particular fusion protein that is soluble (M. Southworth, S. Levitt, and F. Perler, unpub. observ.). However, there are cases when no conditions can be found that result in soluble fusion protein expression. In these cases, the fusion protein can usually be solubilized by dissolving it in 6 M guanidine-HCl or 8 M urea, and then dialyzing away the denaturant. The fusion protein can then be applied to the amylose column for affinity purification. Alternatively, the denatured protein can be purified by conventional means (Nagai and Thøgersen, 1987). One advantage to the latter approach is that insoluble protein is usually very stable and can be purified away from proteases before it is refolded.

A third problem seen with MBP fusion proteins is failure to cleave with factor Xa. There are two possible explanations for this failure. The first involves the primary sequence of the cleavage site. Although factor Xa has a low degree of discrimination for the residue that follows the arginine in its recognition site, it will not cleave if that residue is a proline. The second explanation involves the three-dimensional conformation of the fusion protein. For some fusions, the factor Xa site can be blocked by the protein of interest. In this case, cleavage can often be obtained by denaturing the fusion protein to render the site accessible. However, some proteins remain resistant to cleavage, presumably because the protein quickly refolds into a factor Xa-resistant conformation upon removal of the denaturant. Cleavage can sometimes be facilitated by inserting a spacer between the factor Xa site and the protein of

interest, but this results in extra residues (encoded by the spacer) attached to the amino-terminus of the protein of interest.

Another problem that sometimes arises during factor Xa cleavage is proteolysis at secondary sites within the protein of interest. This problem often (but not always) coincides with instability in *E. coli* during expression of the fusion protein (P. Riggs and I. Hall, unpub. observ.). Cleavage at arginines that are not in the factor Xa site has been observed (Nagai and Thøgersen, 1987; Lauritzen et al., 1991). Because there are arginine residues in other positions that are not cleaved, it is thought that the three-dimensional structure of the protein is important in determining these secondary cleavage sites. Cleavage at lysine residues has also been observed, and can be blocked by reversible acylation of lysine residues at the  $\epsilon$ -amino group (Wearne, 1990).

### Anticipated Results

Fusion protein expressed from pMAL-c2 usually constitutes 20% to 40% of the total cellular protein. Fusion protein expressed from pMAL-p2 usually constitutes 5% to 10% of the total cellular protein. In both cases, a band corresponding to the fusion protein can often be seen by running small samples of uninduced and induced cells on an SDS-polyacrylamide gel (e.g., 400  $\mu$ l of cells at  $\text{OD}_{600} = 0.5$ ; first support protocol). The yield of fusion protein from the affinity purification ranges from  $\leq 1$  mg to 100 mg/liter culture at  $\text{OD}_{600} = 1.0$ ; the remaining fusion protein is present in the column flow-through. The yield varies greatly depending upon the sequences fused to *malE*. In cases where the yield has been compared directly, pMAL-c2 (no signal sequence) gives from 4- to 15-fold more protein in the affinity purification than pMAL-p2.

Approximately 70% of the time, a fusion protein is reasonably stable and will yield  $\geq 1$  mg/liter culture in the affinity purification. When the fusion protein is insoluble or unstable, changing the conditions of expression has helped  $\sim 5\%$  of the time. The rest of the time, affinity purification yields little or no fusion protein. In most of these cases, the fusion protein does not bind well to the column, perhaps because the target protein either blocks or distorts the binding site of MBP. In this situation, it is probably best to purify large amounts of fusion protein by conventional means (*UNITS 10.9-10.16*) or to try a different expression system.

## Time Considerations

Growth of the cells, expression of the fusion protein, and harvest of the cells takes 6 to 7 hr. After harvest, the cells resuspended in column buffer can be stored at  $-20^{\circ}\text{C}$  for  $\geq 1$  month. The thawed cell suspension should be stored for as short a time as possible, but once the crude extract is made and diluted 1:5 with column buffer, the fusion protein is usually reasonably stable at  $4^{\circ}\text{C}$ . After sonication and centrifugation of the cell debris, the crude extract (or the diluted crude extract) can again be frozen at  $-20^{\circ}\text{C}$  for  $\geq 1$  month. Affinity chromatography takes  $\sim 9$  hr and should be done in one day, if at all possible; if the fusion protein is left on the column too long, it starts to lose affinity for the amylose matrix. This may be due to maltose that is released from the column by trace amounts of amylase that are purified from *E. coli* along with the fusion protein. The purified protein can be stored for short periods of time (1 day) at  $4^{\circ}\text{C}$ , or at  $-20^{\circ}\text{C}$  for long-term storage. Many proteins denature after freezing and thawing, so freezing in small aliquots or with the addition of 50% glycerol is recommended.

## Literature Cited

- Amann, E. and Brosius, J. 1985. 'ATG vectors' for regulated high-level expression of cloned genes in *Escherichia coli*. *Gene* 40:183-190.
- Baker, T.A., Grossman, D., and Gross, C.A. 1984. A gene regulating the heat shock response in *Escherichia coli* also affects proteolysis. *Proc. Natl. Acad. Sci. U.S.A.* 81:6779-6783.
- Bardwell, J.C.A., McGovern, K., and Beckwith, J. 1991. Identification of a protein required for disulfide bond formation in vivo. *Cell* 67:581-589.
- Bedouelle, H. and Duplay, P. 1988. Production in *Escherichia coli* and one-step purification of bifunctional hybrid proteins which bind maltose. *Eur. J. Biochem.* 171:541-549.
- Duplay, P., Bedouelle, H., Fowler, A., Zabin, I., Saurin, W., and Hofnung, M. 1984. Sequences of the *malE* gene and of its product, the maltose-binding protein of *Escherichia coli* K12. *J. Biol. Chem.* 259:10606-10613.
- Gentz, R., Kuys, Y., Zwieb, C., Taatjes, D., Taatjes, H., Bannwarth, W., Stueber, D., and Ibrahim, I. 1988. Association of degradation and secretion of three chimeric polypeptides in *Escherichia coli*. *J. Bacteriol.* 170:2212-2220.
- Grodberg, J. and Dunn, J.J. 1988. *ompT* encodes the *Escherichia coli* outer membrane protease that cleaves T7 RNA polymerase during purification. *J. Bacteriol.* 170:1245-1253.
- Guan, C., Li, P., Riggs, P.D., and Inouye, H. 1987. Vectors that facilitate the expression and purification of foreign peptides in *Escherichia coli* by fusion to maltose-binding protein. *Gene* 67:21-30.
- Hsiung, H.M., Mayne, N.G., and Becker, G.W. 1986. High level expression, efficient secretion, and folding of human growth hormone in *Escherichia coli*. *BioTechnology* 4:991-995.
- Kellerman, O.K. and Ferenci, T. 1982. Maltose binding protein from *E. coli*. *Methods Enzymol.* 90:459-463.
- Lauritzen, C., Tüchsen, E., Hansen, P.E., and Skovgaard, O. 1991. BPTI and N-terminal extended analogues generated by Factor Xa cleavage and cathepsin C trimming of a fusion protein expressed in *Escherichia coli*. *Prot. Expr. Purif.* 2:372-378.
- Maina, C.V., Riggs, P.D., Granda, A.G. III, Slatko, B.E., Moran, L.S., Tagliamonte, J.A., McReynolds, L.A., and Guan, C. 1988. A vector to express and purify foreign proteins in *Escherichia coli* by fusion to, and separation from, maltose binding protein. *Gene* 74:365-373.
- Nagai, K. and Thøgersen, H.C. 1984. Generation of  $\beta$ -globin by sequence-specific proteolysis of a hybrid protein produced in *Escherichia coli*. *Nature* 309:810-812.
- Nagai, K. and Thøgersen, H.C. 1987. Synthesis and sequence-specific proteolysis of hybrid proteins produced in *Escherichia coli*. *Methods Enzymol.* 153:461-481.
- Neu, H.C. and Heppel, L.A. 1965. The release of enzymes from *Escherichia coli* by osmotic shock and during the formation of spheroplasts. *J. Biol. Chem.* 240:3685-3692.
- Reidhaar-Olson, J.F., Parsell, D.A., and Sauer, R.T. 1990. An essential proline in  $\lambda$  repressor is required for resistance to intracellular proteolysis. *Biochemistry* 29:7563-7571.
- Schein, C.H. 1989. Production of soluble recombinant proteins in bacteria. *BioTechnology* 7:1141-1149.
- Silber, K.R., Keiler, K.C., and Sauer, R.T. 1992. Tsp: A tail-specific protease that selectively degrades proteins with nonpolar C termini. *Proc. Natl. Acad. Sci. U.S.A.* 89:295-299.
- Silhavy, T.J., Szmelcman, S., Boos, W., and Schwartz, M. 1975. On the significance of the retention of ligand by protein. *Proc. Natl. Acad. Sci. U.S.A.* 72:2120-2124.
- Strauch, K.L. and Beckwith, J. 1988. An *Escherichia coli* mutation preventing degradation of abnormal periplasmic proteins. *Proc. Natl. Acad. Sci. U.S.A.* 85:1576-1580.
- Straus, D.B., Walter, W.A., and Gross, C.A. 1988. *Escherichia coli* heat shock gene mutants are defective in proteolysis. *Genes Dev.* 2:1851-1858.
- Sugimura, K. and Higashi, N. 1988. A novel outer-membrane-associated protease in *Escherichia coli*. *J. Bacteriol.* 170:3650-3654.

Takagi, H., Morinaga, Y., Tsuchiya, M., Ikemura, G., and Inouye, M. 1988. Control of folding of proteins secreted by a high expression secretion vector, pIN-III-ompA: 16-fold increase in production of active subtilisin E in *Escherichia coli*. *Bio/Technology* 6:948-950.

Wearne, S.J. 1990. Factor Xa cleavage of fusion proteins: Elimination of nonspecific cleavage by reversible acylation. *FEBS Lett.* 263:23-26.

Yanisch-Perron, C., Vieira, J., and Messing, J. 1985. Improved M13 phage cloning vectors and host strains: Nucleotide sequences of the M13mp18 and pUC19 vectors. *Gene* 33:103-119.

Zagursky, R.J. and Berman, M.L. 1984. Cloning vectors that yield high levels of single stranded DNA for rapid DNA sequencing. *Gene* 27:183-191.

---

Contributed by Paul Riggs  
New England Biolabs  
Beverly, Massachusetts

**Protein  
Expression**

---

**16.6.14**

# Expression and Purification of Glutathione-S-Transferase Fusion Proteins

UNIT 16.7

BASIC  
PROTOCOL

This unit describes how pGEX vectors can be used in bacterial systems to express foreign polypeptides as fusions with glutathione-S-transferase (GST). In general, such fusion proteins are soluble and are easily purified from lysed cells under nondenaturing conditions by absorption with glutathione-agarose beads, followed by elution in the presence of free glutathione. Potential applications of the pGEX vectors include the expression and purification of individual polypeptides (including short peptides) for use as immunogens and as biochemical and biological reagents, and in the construction of cDNA expression libraries.

The screening procedure given here has the advantage (over restriction analysis of plasmid DNA, for example) of rapidly identifying transformants that express fusion proteins, and also revealing whether such fusion proteins are readily purified by the affinity absorption step. If true transformants are likely to be rare because of a high background with the vector alone, screening is better conducted by DNA hybridization to lysed colonies (UNITS 6.3 & 6.4) or by immunological screening (UNITS 6.7 & 6.8).

This protocol describes production and screening of pGEX transformants and purification of milligram quantities of fusion proteins from 1-liter cultures. UNIT 16.4B describes removal of the GST portion of a fusion protein by cleavage with site-specific proteases. Because the vagaries of heterologous protein expression in *Escherichia coli* are such that the basic protocol for purifying fusion proteins may not always suffice, Critical Parameters and Troubleshooting describe several modifications to the expression and purification protocol that may be useful in cases where fusion proteins are insoluble or unstable.

Each pGEX vector contains an open reading frame encoding GST, followed by unique restriction endonuclease sites for *Bam*HI, *Sma*I, and *Eco*RI, followed in turn by termination codons in all three frames (Fig. 16.7.1). The cloning sites are present in a different reading frame in each of the three vectors, so the vector in which the foreign polypeptide will be expressed in-frame with GST must be chosen first. pGEX2T or pGEX3X should be used if the GST carrier is eventually to be removed by site-specific proteolysis (UNIT 16.4B). Fusion proteins produced using pGEX1 can be cleaved by chemical hydrolysis at low pH (UNIT 16.4B).

## Materials

For recipes, see *Reagents and Solutions* in this unit (or cross-referenced unit); for common stock solutions, see APPENDIX 2; for suppliers, see APPENDIX 4.

- pGEX vector (pGEX1 from Amrad or pGEX2T and pGEX3X from Pharmacia Biotech)
- Transformation-competent *Escherichia coli* (UNIT 1.8)
- LB plates containing 50 µg/ml ampicillin (UNIT 1.1)
- LB medium containing 10 µg/ml ampicillin (UNIT 1.1)
- 100 mM isopropyl-1-thio-β-D-galactoside (IPTG), filter sterilized
- Phosphate-buffered saline (PBS; APPENDIX 2), ice-cold
- Glutathione-agarose bead slurry (see recipe)
- 2× SDS sample buffer (UNIT 10.2)
- 10% (v/v) Triton X-100
- 50 mM Tris·Cl (pH 8.0)/5 mM reduced glutathione (freshly prepared; pH 7.5, final)
- Glycerol
- 37°C shaking incubator
- Beckman JA-10 and JA-20 rotors (or equivalents)
- Probe sonicator (with 2- and 5-mm-diameter probes)

Protein  
Expression

## 16.7.1

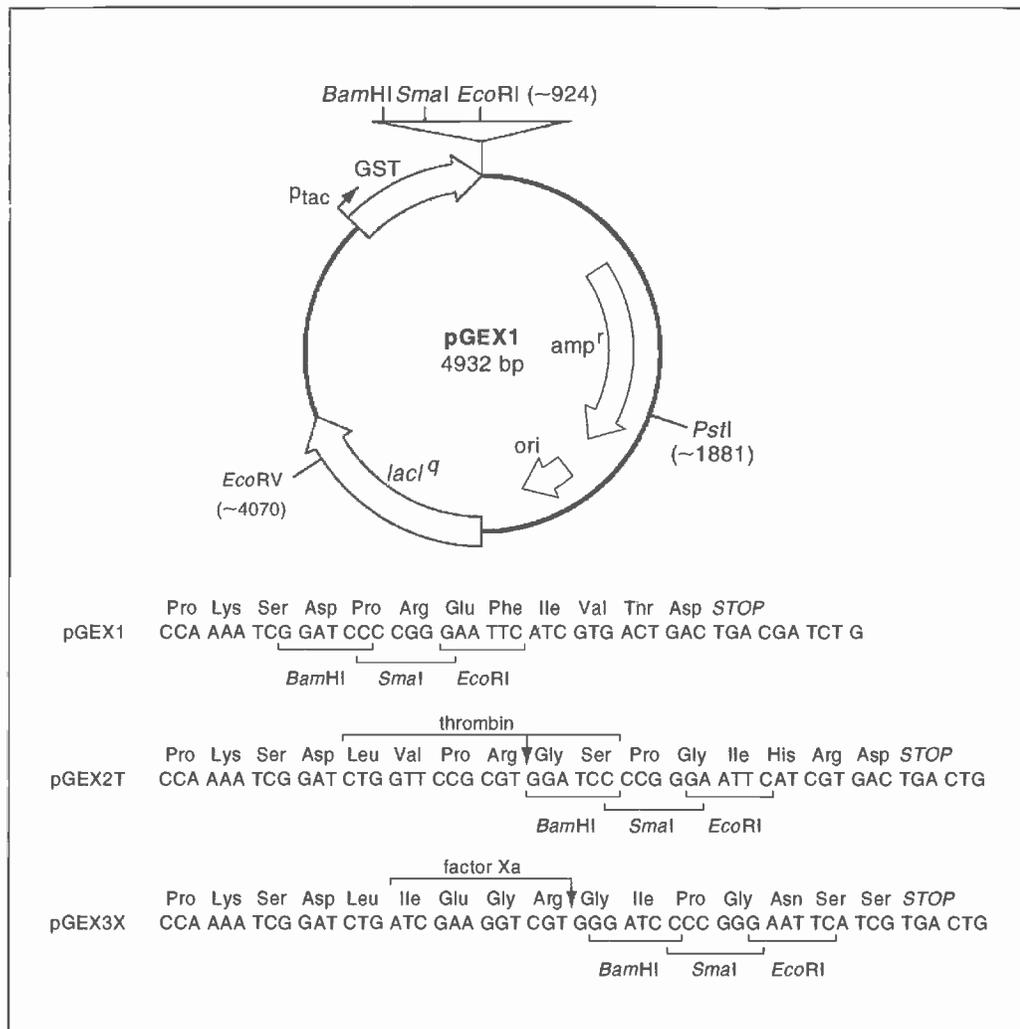

**Figure 16.7.1 pGEX1.** pGEX1 is a fusion-protein expression vector that expresses a cloned gene as a fusion protein to GST. The *lac* repressor (product of the *lacI* gene) binds to the  $\mu_{tac}$  promoter, repressing the expression of GST fusion protein. Upon induction with IPTG, derepression occurs and GST fusion protein is expressed. The gene of interest can be inserted into the polylinker located at the end of the GST gene. The polylinker sequences are shown below the map of pGEX1, where the restriction endonuclease cloning sites are bracketed. The polylinker of pGEX2T and pGEX3X contains protease cleavage sites so the cloned protein can be released from the GST moiety (or "carrier"). The recognition sequences for thrombin and factor Xa are bracketed above the polylinker sequences, with the actual cleavage site between Arg and Gly. The nucleotide sequence of pGEX1 is available under Genbank accession number M21676.

Additional reagents and equipment for subcloning DNA fragments (UNITS 1.4 & 3.16), SDS-PAGE (UNIT 10.2), and Coomassie blue staining (UNIT 10.6)

### Produce and analyze transformants

1. Subclone the chosen DNA fragment into the appropriate pGEX vector in the correct reading frame, transform competent *E. coli* cells, and select transformants on LB/ampicillin plates. Incubate plates 12 to 15 hr at 37°C.

*Include a control of vector ligated to itself in the absence of insert DNA. Unless the insert DNA is being cloned with ends generated by digestion with two different restriction endonucleases, treat the vector with phosphatase after digestion to minimize screening. Any standard *E. coli* strain should be suitable for this transformation because the *lacI<sup>q</sup>* repressor allele that controls expression of the fusion protein via the *tac* promoter (a *trp/lac* promoter fusion) is present on each pGEX vector.*

- Pick transformant colonies into 2 ml LB/ampicillin medium and streak out onto a master LB/ampicillin plate. Inoculate a control tube with bacteria transformed with the parental pGEX vector. Incubate the master plate 12 to 15 hr at 37°C. Grow liquid cultures with vigorous agitation in a 37°C shaking incubator until visibly turbid (3 to 5 hr).

*The number of transformants to be screened can be judged from the number over background obtained with the self-ligated vector alone.*

- Induce fusion protein expression by adding 100 mM IPTG to 0.1 mM. Continue incubation another 1 to 2 hr.
- Transfer liquid cultures to labeled microcentrifuge tubes, microcentrifuge 5 sec at maximum speed, room temperature, and discard supernatants. Resuspend pellets in 300 µl ice-cold PBS. Remove 10 µl to labeled tubes (for use in step 7).

*Except where noted, keep all samples and tubes on ice.*

- Lyse cells using a probe sonicator with a 2-mm-diameter probe. Microcentrifuge 5 min at maximum speed, 4°C, to remove insoluble material. Transfer supernatants to fresh tubes.

*Lysis is complete when the cloudy cell suspension becomes translucent. The frequency and intensity of sonication should be adjusted so no frothing occurs and so lysis is complete in 10 sec. For a Tekmar Sonic Disruptor with a microtip probe, the output frequency should be set to the microtip limit noted on the dial. An alternative to sonication that may be useful when large numbers of samples have to be processed is lysis by repeated cycles of freezing in dry ice followed by thawing at 20°C. However, fusion proteins are more likely to suffer degradation with the freeze-thaw method.*

- Add 50 µl of 50% slurry of glutathione-agarose beads to each supernatant and mix gently  $\geq 2$  min at room temperature. Add 1 ml PBS, vortex briefly, microcentrifuge 5 sec at maximum speed, room temperature to collect beads, and discard supernatants. Repeat the PBS wash twice.
- Add an equal volume of 1× SDS sample buffer to the washed beads, and 30 µl to the 10-µl samples of resuspended whole cells (from step 4). Heat 3 min at 100°C, vortex briefly, and load onto a 10% SDS-polyacrylamide gel. Run the gel for the appropriate time and stain with Coomassie blue solution to visualize the parental GST (made in control cells carrying a pGEX vector) and the fusion protein (Fig. 16.7.2).

*Ideally, transformants expressing the desired fusion protein will be identified by the absence from total cellular proteins of the 27.5-kDa molecule specified by parental pGEX vectors, and by the presence of a novel, larger species. Where two orientations of the insert DNA are possible, the relative mobilities of the new species should distinguish between them; otherwise, conventional restriction endonuclease analysis will be required (UNIT 3.1). If the fusion protein has adsorbed to the glutathione-agarose beads, proceed to large-scale purification as in steps 8 to 15. If, on the other hand, the fusion protein is absent from the purified material, it may be insoluble; see Critical Parameters and Troubleshooting for a discussion of this problem and for instances where neither the 27.5-kDa protein nor a larger fusion protein is visible (perhaps indicating toxicity or instability of the fusion protein). Interpretation is sometimes complicated when unstable fusion proteins break down and release the 27.5-kDa GST moiety. Such cases are usually recognized by the reduced level of the 27.5-kDa species, and by the series of larger, partial proteolytic fragments above it.*

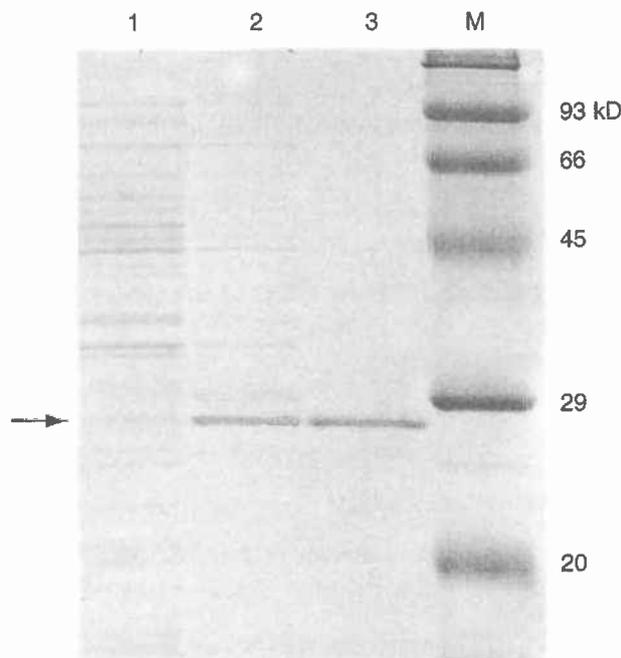

**Figure 16.7.2** Stained protein gel showing expression of GST. The total cell lysate of a pGEX1 transformant is shown before IPTG induction (lane 1) and after IPTG induction (lane 2). The GST protein after elution from glutathione-agarose beads is shown at the position indicated by the arrow (lane 3). The lane marked M contains molecular-weight markers for sizes indicated.

#### ***Purify fusion proteins on a large scale***

8. Inoculate a colony of the pGEX transformant into 100 ml LB/ampicillin medium and grow 12 to 15 hr at 37°C in a shaking incubator.
9. Dilute this culture 1:10 into 1 liter fresh LB/ampicillin medium, split between two 2-liter flasks, and grow 1 hr at 37°C.
10. Add 100 mM IPTG to 0.1 mM (final) and continue incubation an additional 3 to 7 hr.

*By optimizing growth conditions, the yield of fusion protein may be greatly improved. Investigate the effects of delaying the addition of IPTG and altering the induction period. For example, if the fusion protein is not detrimental to the growth of the bacteria, and the protein is stable, the yield may be improved by increasing the duration of the induction period. However, if the protein is detrimental to the cells, the yield may be improved by delaying the addition of IPTG until the culture is more dense (i.e., when more cells are present) and also by decreasing the duration of induction, to decrease cell loss during this period.*

11. Centrifuge 10 min at 5000 × g (~5500 rpm in a Beckman JA-10 rotor), room temperature, to collect cells. Discard supernatant and resuspend pellet in 10 to 20 ml ice-cold PBS.
12. Immerse the tube in ice and lyse cells using a probe sonicator with a 5-mm-diameter probe.

*Lysis can be detected as a change in color from a rich straw brown (intact cells) to a dull gray-brown (lysed cells). Adjust the frequency and intensity of sonication so lysis occurs in ~30 sec, without frothing. Excessive sonication can result in contamination of purified fusion protein with other proteins. Lysis by freeze-thaw is a slower alternative.*

13. Add 10% Triton X-100 to 1% (final) and mix. Centrifuge 5 min at 10,000 × g (~9500 rpm in a Beckman JA-20 rotor), 4°C, to remove insoluble material and intact cells. Alternatively, it may be convenient to microcentrifuge 1.5-ml aliquots for 5 min at top speed, 4°C. Collect supernatants (carefully avoiding the pellets) and pool them.

*Triton X-100 is added to the lysed cells to minimize association of fusion protein with*

*bacterial proteins, and thus to prevent appearance of these contaminants in the final preparation.*

14. Add supernatant to 1 ml of 50% slurry of glutathione-agarose beads and mix gently  $\geq 2$  min at room temperature. Wash by adding 50 ml ice-cold PBS, mixing, and centrifuging 10 sec in a tabletop centrifuge at  $500 \times g$ , room temperature. Repeat the wash two more times. Resuspend the beads in a small volume (1 to 2 ml) of ice-cold PBS and transfer to a 1.5-ml microcentrifuge tube.

*The capacity of glutathione-agarose is  $\geq 8$  mg protein/ml swollen beads.*

*To remove the GST carrier by protease cleavage, see UNIT 16.4B.*

15. Centrifuge 10 sec at  $500 \times g$ , room temperature, to collect beads; discard supernatant. Elute fusion protein by adding 1 ml of 50 mM Tris-Cl (pH 8.0)/5 mM reduced glutathione. Mix gently 2 min, centrifuge 10 sec at  $500 \times g$ , and collect supernatant. Repeat elution two to three times and analyze each fraction by SDS-PAGE. Store eluted protein in aliquots containing 10% glycerol at  $-70^\circ\text{C}$ .

*The majority of fusion protein should appear in the first two elutions. If a concentrated solution of the fusion protein is required, elution can be carried out while the beads are immobilized in a small column. See Critical Parameters and Troubleshooting regarding problems with contamination, instability, or yield. The concentration of glutathione in the elution buffer may be increased to 10 or 15 mM if the fusion protein is not quantitatively eluted using the lower concentration. Determine the yield of fusion protein by measuring the absorbance at 280 nm. For the GST carrier,  $A_{280} = 1$  corresponds to a protein concentration of 0.5 mg/ml.*

## REAGENTS AND SOLUTIONS

*Use deionized, distilled water in all recipes and protocol steps. For common stock solutions, see APPENDIX 2; for suppliers, see APPENDIX 4.*

### *Glutathione-agarose bead slurry*

Preswell *S*-linkage glutathione-agarose beads (Sigma or Pharmacia Biotech) 1 hr in 10 vol phosphate-buffered saline (PBS, APPENDIX 2). Wash twice with PBS and store as a 50% (v/v) slurry  $\leq 1$  month at  $4^\circ\text{C}$ .

*The beads can be recycled by boiling 5 min in PBS containing 1% SDS (Frangioni and Neel, 1993), but should then only be used to purify the same fusion protein to prevent cross-contamination.*

## COMMENTARY

### **Background Information**

The pGEX vectors are designed so that foreign polypeptides can be expressed in *Escherichia coli* in a form that allows them to be purified rapidly under nondenaturing conditions (Smith and Johnson, 1988). Foreign polypeptides are expressed as fusions to the C terminus of glutathione-*S*-transferase (GST), a common 26-kDa cytoplasmic protein of eukaryotes. The GST gene used to generate the pGEX vectors was originally cloned from the parasitic helminth, *Schistosoma japonicum* (Smith et al., 1986).

The fusion proteins typically remain soluble within the bacteria and can be purified from

lysed cells because of the affinity of the GST moiety for glutathione immobilized on agarose beads. Recovery of the fusion proteins is by elution with free reduced glutathione at neutral pH.

The main advantage of this system for expressing and recovering foreign proteins from *E. coli* is that most fusion proteins remain soluble; native proteins expressed in *E. coli* often denature and precipitate. Furthermore, denaturing conditions are not required at any stage during purification, and consequently, foreign polypeptides may retain their functional activities and antigenicity. Additional features are the efficiency and rapidity of puri-

fication, the high level of inducible expression achieved with the strong tac promoter, and the broad range of suitable bacterial hosts (because the pGEX vectors carry the *lacI<sup>q</sup>* repressor allele). Furthermore, the GST carrier is small compared to other carriers (e.g.,  $\beta$ -galactosidase), and lacks the immunological complications of fusion proteins containing fragments of protein A. (Peptides containing protein A are likely to interact and/or combine with a wide variety of antibodies, but the GST moiety will not interfere with specific antibody-antigen interactions.)

The main determinant for successful purification of foreign polypeptides using the pGEX system is solubility of the fusion protein. To some extent, this can only be discovered empirically. More difficulties are encountered as the size of the desired fusion protein increases (particularly when >50 kDa), or when the protein contains regions that are strongly hydrophobic or highly charged (D.B.S. and L.M.C., unpub. observ.). Insoluble fusion proteins can sometimes be coaxed into solution (see Troubleshooting) or can otherwise be purified after solubilization in denaturing reagents.

If necessary, the GST moiety can be removed from fusion proteins by cleavage with site-specific proteases (UNIT 16.4B). Note however, that often the GST carrier does not compromise the antigenicity or functional activity of the foreign polypeptide. Modified versions of the original pGEX vectors have been produced that simplify cloning, cleavage or detection of fusion proteins (for review, see Smith, 1993).

### Critical Parameters and Troubleshooting

Contamination of fusion proteins by host cell proteins is usually a sign that sonication has been too severe, perhaps because denaturation exposes regions on proteins that are more likely to cause aggregation. Some contaminating species may represent degraded fragments of the fusion protein that bind to glutathione. Such fragments are not easy to eliminate, except by increasing the stability of the fusion protein. The addition of protease inhibitors [e.g., 1% (w/v) aprotinin and 1 mM phenylmethylsulfonyl fluoride (PMSF)] may help in this regard, and inclusion of 50 to 100 mM EDTA in the lysis buffer has also been beneficial. The *E. coli* host strain can have a major and unpredictable effect on stability, and it is worth testing several different strains, including the protease-deficient *lon*<sup>-</sup> strains (D.B.S.

and L.M.C., unpub. observ.; UNIT 1.4). Alternatively, degradation of fusion proteins can be minimized by adding isopropyl-1-thio- $\beta$ -D-galactoside (IPTG) later in the course of the culture and keeping the induction period to a minimum. The overall yield of fusion protein can sometimes be improved by increasing the quantity of glutathione-agarose beads, minimizing the volume of liquid during absorption, and extending the period of absorption to 1 hr.

Insolubility of fusion proteins can be addressed by several means. In some cases, growth of cells at 30°C is sufficient to alter solubility (D.B.S., unpub. observ.), but in other cases it may be necessary to investigate the effect of mild detergent treatment after cell lysis. Examples of conditions under which binding of GST to glutathione-agarose is unaffected are 1% Triton X-100, 1% Tween-20, 1% CTAB, 10 mM DTT, and 0.03% SDS. Alternatively, fusion proteins can be solubilized in 1% to 2% Sarkosyl prior to sonication; they can be solubilized in 2% to 4% Triton X-100 prior to binding to glutathione agarose (Frangioni and Neel, 1993). Even if a fusion protein is largely insoluble, it may be possible to purify the small proportion that is still soluble, with a yield of perhaps 50  $\mu$ g/liter. Otherwise, a fusion protein that is abundant, but stubbornly insoluble, can be purified by gel filtration after solubilization under denaturing conditions or by electroelution from a gel after SDS-PAGE.

A different approach is to express the polypeptide as smaller fragments, particularly if it is possible to express parts of the protein that do not contain severely hydrophobic or highly charged regions. If the fusion protein is not of the expected size, it may be worth sequencing across the cloning site to ensure that the reading frame of the vector and the insert are matched. There is a hairpin in GST sequences near the cloning sites, so a sequencing primer complementary to either the extreme 3' end of the GST gene or to sequences within the DNA insert should be used.

### Anticipated Results

Yields of fusion protein vary from more typical yields of 1 to 3 mg/liter up to 10 mg/liter, and can be as low as 50  $\mu$ g/liter if most of the fusion protein is insoluble. The single affinity chromatography step can generate fusion protein preparations that are >90% pure.

### Time Considerations

A full day is required to screen colonies of transformants for expression of fusion proteins,

although continuous attention is not required. Large-scale purification and cleavage of fusion proteins require another day of intermittent work. Cells can be stored as pellets at  $-70^{\circ}\text{C}$  before lysis, although with fusion proteins that are unstable, this may be undesirable. Purification is best completed in one session.

### Literature Cited

- Frangioni, J.V. and Neel, B.G. 1993. Solubilization and purification of enzymatically active glutathione-S-transferase (pGEX) fusion proteins. *Anal. Biochem.* 210:179-187.
- Smith, D.B. 1993. Purification of glutathione-S-transferase fusion proteins. *Methods Mol. Cell Biol.* 4:220-229.
- Smith, D.B., Davern, K.M., Board, P.G., Tiu, W.U., Garcia, E.G., and Mitchell, G.F. 1986. Mr 26,000 antigen of *Schistosoma japonicum* recognized by resistant WEHI 129/J mice is a parasite glutathione S-transferase. *Proc. Natl. Acad. Sci. U.S.A.* 83:8703-8707.

### Key Reference

- Smith et al., 1986. See above.  
*Original description of the pGEX system.*
- Smith, 1993. See above.  
*Summary of modified pGEX vectors and alternative purification methods.*
- Smith, D.B. and Johnson, K.S. 1988. Single-step purification of polypeptides expressed in *Escherichia coli* as fusions with glutathione S-transferase. *Gene* 67:31-40.  
*First description of GST fusion system.*

---

Contributed by Donald B. Smith  
University of Edinburgh  
Edinburgh, Scotland

Lynn M. Corcoran  
Walter & Eliza Hall Institute  
Victoria, Australia

# Expression and Purification of Thioredoxin Fusion Proteins

This unit describes a gene fusion expression system that uses thioredoxin, the product of the *Escherichia coli trxA* gene, as the fusion partner. The system is particularly useful for high-level production of soluble fusion proteins in the *E. coli* cytoplasm; in many cases heterologous proteins produced as thioredoxin fusion proteins are correctly folded and display full biological activity. Although the thioredoxin gene fusion system is routinely used for protein production, high-level production of peptides—i.e., for use as antigens—is also possible because the prominent thioredoxin active-site loop is a very permissive site for the introduction of short amino acid sequences (10 to 30 residues in length). The inherent thermal stability of thioredoxin and its susceptibility to quantitative release from the *E. coli* cytoplasm by osmotic shock can also be exploited as useful tools for thioredoxin fusion protein purification. In addition, a more generic method for purification of any soluble thioredoxin fusion employs a modified form of thioredoxin (called “His-patch Trx”), which has been designed to bind to metal chelate resins. Protein fusions to His-patch Trx can usually be purified in a single step from cell lysates (see Strategic Planning).

The basic protocol outlines the construction of a fusion of *trxA* to any desired gene and expression of the fusion protein in an appropriate host strain at 37°C. Additional protocols describe *E. coli* cell lysis using a French pressure cell and fractionation (first support protocol), osmotic release of thioredoxin fusion proteins from the *E. coli* cytoplasm (second support protocol), and heat treatment to purify some thioredoxin fusion proteins (third support protocol).

## STRATEGIC PLANNING

The thioredoxin gene fusion expression vectors pTRXFUS and hpTRXFUS, both of which carry the *E. coli trxA* gene (Fig. 16.8.1), are used for high-level production of C-terminal fusions to thioredoxin. The vector hpTRXFUS differs from pTRXFUS in that it contains a modified *E. coli trxA* gene which produces a mutant protein (“His-patch” thioredoxin) that can specifically bind to metal chelate matrices charged with nickel or cobalt, otherwise known as native metal-chelate affinity chromatography (MCAC; UNIT 10.11B). The *trxA* translation termination codon has been replaced in both vectors by DNA encoding a ten-residue peptide linker sequence that includes an enterokinase (enteropeptidase; LaVallie et al., 1993a) cleavage site. This highly specific site can be cleaved with enterokinase following purification of the fusion protein to release the protein of interest from its thioredoxin fusion partner (cleavage of the fusion protein is covered in UNIT 16.4B). Immediately downstream of the DNA encoding the enterokinase site in pTRXFUS and hpTRXFUS lies a DNA polylinker sequence containing a number of unique restriction endonuclease sites that can be used for forming in-frame translational fusions of any desired gene to *trxA*. Downstream of the DNA polylinker lies the *E. coli aspA* transcription terminator. Replication of these vectors is controlled by a modified colE1 replication origin similar to that found in pUC vectors (Norrande et al., 1983). Plasmid selection and maintenance is ensured by the presence of the  $\beta$ -lactamase gene on the vector. The vector pALtrxA-781 (Fig. 16.8.1) is very similar to pTRXFUS. However in this plasmid the *trxA* gene is followed by a translation termination codon, and the sequences encoding the enterokinase-site peptide linker are absent. A unique *RsrII* site, present in both pALtrxA-781 and pTRXFUS, allows for the easy insertion of short peptide-encoding DNA sequences into *trxA* within the region that encodes the active-site loop.

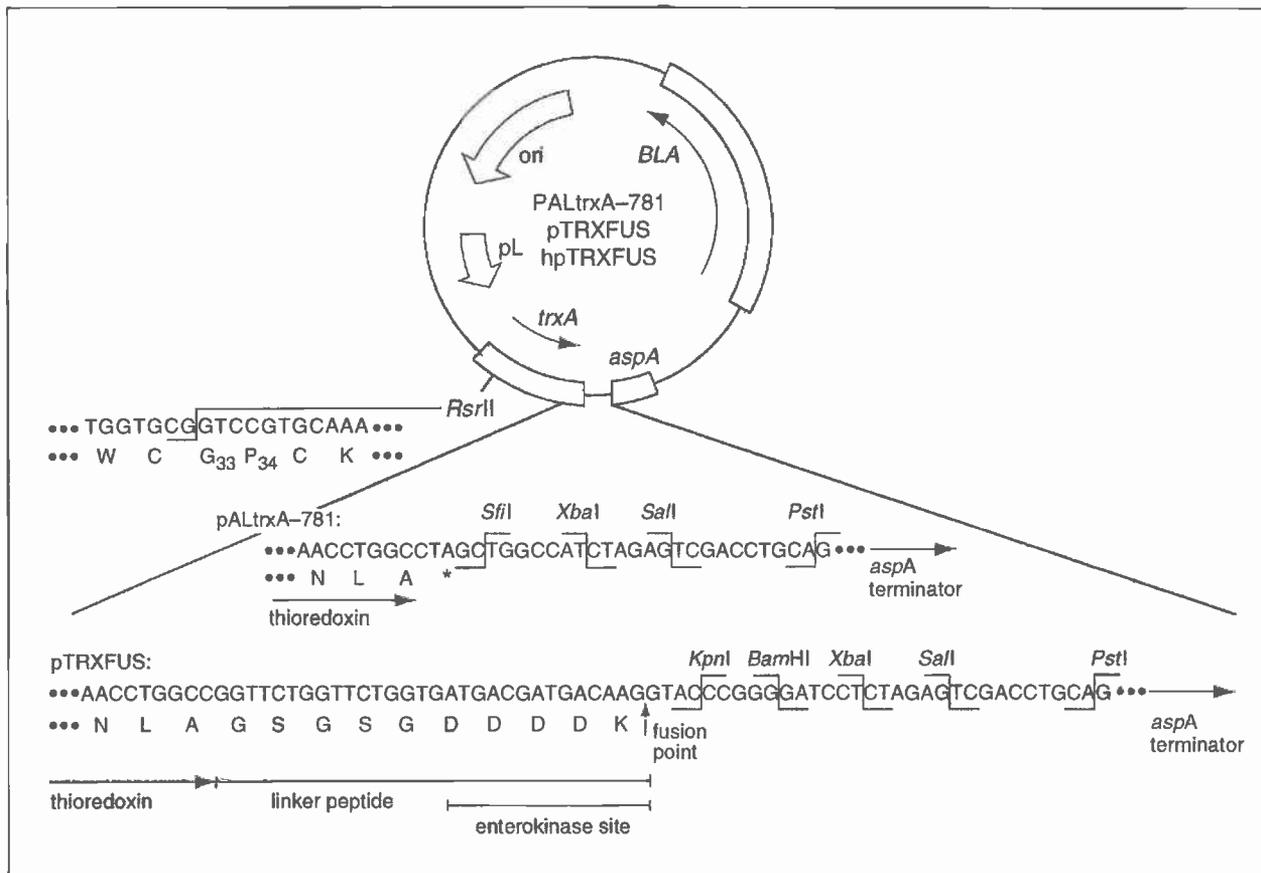

**Figure 16.8.1** Thioredoxin gene fusion expression vectors pTRXFUS, hpTRXFUS, and pALtrxA-781. pALtrxA-781 contains a polylinker sequence at the 3' end of the *trxA* gene. pTRXFUS and hpTRXFUS contain a linker region encoding a peptide that includes the enterokinase cleavage site between the *trxA* gene and the polylinker. The sequence surrounding the active site loop of thioredoxin has a single *RsrII* site that can be used to insert peptide coding sequence. The asterisk indicates a translational stop codon. Abbreviations: *trxA*, *E. coli* thioredoxin gene; *BLA*,  $\beta$ -lactamase gene; *ori*, *colE1* replication origin; *pL*, bacteriophage  $\lambda$  major leftward promoter; *aspA* terminator, *E. coli* aspartate amino-transferase transcription terminator.

pTRXFUS, hpTRXFUS, and pALtrxA-781 carry the strong bacteriophage  $\lambda$  promoter pL (Shimatake and Rosenberg, 1981) positioned upstream of the *trxA* gene. Transcription initiation at the pL promoter is controlled by the intracellular concentration of  $\lambda$  repressor protein (cI). UNIT 16.3 describes  $\lambda$  strains that carry either a temperature-sensitive form of cI (cI<sup>857</sup>) or a wild-type cI repressor protein. cI<sup>857</sup>-containing strains can be used for heat inductions of pL at 42°C; alternatively, in the strains carrying the wild-type repressor, pL can be induced by a prior induction of the *E. coli* SOS stress response. However, it is often desirable to express heterologous genes in *E. coli* at temperatures considerably lower than 42°C, or under conditions where cells are not undergoing a physiological stress. Strains GI698, GI724 and GI723 were designed to allow the growth and induction of pL expression vectors, including pTRXFUS, hpTRXFUS, and pALtrxA-781, under mild conditions over a wide range of temperatures (see Table 16.8.1; Mieschendahl et al., 1986). Each of these strains carries a wild-type allele of cI stably integrated into the *E. coli* chromosome at the nonessential *ampC* locus. A synthetic *trp* promoter integrated into *ampC* upstream of the cI gene in each strain directs the synthesis of cI repressor only when intracellular tryptophan levels are low. When tryptophan levels are high, synthesis of cI is switched off; therefore, the presence of tryptophan in the growth medium of GI698, GI723, or GI724 will block expression of  $\lambda$  repressor and thus will turn on pL. Because

**Table 16.8.1** *E. coli* Strains for Production of Thioredoxin Fusion Proteins at Varying Temperatures

Strain	Desired production temperature (°C)	Pre-induction growth temperature (°C)	Induction period (hr)
GI698	15	25	20
GI698	20	25	18
GI698	25	25	10
GI724	30	30	6
GI724	37	30	4
GI723	37	37	5

the three strains carry ribosome-binding sequences of different strengths at the 5'-end of their respective cI genes, they maintain intracellular concentrations of  $\lambda$  repressor that increase in the order GI698 < GI724 < GI723. The choice of which strain to use for a particular application is dependent on the desired culture conditions as described below.

Although some thioredoxin fusion proteins produced at 37°C are insoluble, expression at lower temperatures can often result in the fusion protein being produced in a soluble form. Each of the three pL host strains GI698, GI723, and GI724 is suitable for the production of thioredoxin fusion proteins over a particular temperature range. Table 16.8.1 indicates the correct strain for expression of thioredoxin fusion proteins at any temperature between 15°C and 37°C. The induction protocol at any of these temperatures is the same as that described in the basic protocol for induction of GI724 at 37°C, except the preinduction growth temperature and the length of the induction period vary according to the strain used and the temperature chosen. Cultures should be grown at the indicated preinduction growth temperature until they reach a density of 0.4 to 0.6 OD<sub>550</sub>/ml. They should then be moved to the desired induction temperature and induced by the addition of 100 µg/ml tryptophan.

Low-temperature inductions are best performed in strain GI698. However, this strain makes only enough cI repressor protein to maintain the vectors in an uninduced state at temperatures below 25°C. GI698 should therefore never be grown above 25°C when it carries a pL plasmid. A nonrefrigerated water bath can be maintained below room temperature by placing it in a 4°C room and setting the thermostat to the desired temperature.

It is often a good idea to collect timepoints during the course of a long induction period and to fractionate cells from these timepoints using the procedure in the first support protocol (steps 9 to 13). Although a particular fusion protein may be soluble during the early part of an induction, during the later phases of induction, it may become unstable or its concentration inside the cell may exceed a critical threshold above which it will precipitate and appear in the insoluble fraction.

**CONSTRUCTION AND EXPRESSION OF A THIOREDOXIN  
FUSION PROTEIN**

This protocol describes construction and subsequent expression of a gene fusion between *trxA* (encoding thioredoxin) and a gene encoding a particular protein or peptide. After a clone carrying the correct fusion sequence is constructed, analyzed, and isolated, cultures are grown and expression is induced. The protocol is described in terms of the *E. coli* host strain GI724 with expression at 30°C; it may also be applied to strains GI698 and GI723 (also available from Genetics Institute) for expression at other temperatures by using the parameters specified in Table 16.8.1 (see Strategic Planning).

**Materials**

*For recipes, see Reagents and Solutions in this unit (or cross-referenced unit); for common stock solutions, see APPENDIX 2; for suppliers, see APPENDIX 4.*

- DNA fragment encoding desired sequence
- Thioredoxin expression vectors (Fig. 16.8.1): pTRXFUS or pALtrxA-781 (Genetics Institute or Invitrogen) or hpTRXFUS (Genetics Institute)
- E. coli* strain GI724 (Genetics Institute or Invitrogen), grown in LB medium and made competent (UNIT 1.8)
- LB medium (UNIT 1.1)
- IMC plates containing 100 µg/ml ampicillin (see recipe)
- CAA/glycerol/ampicillin 100 medium (see recipe)
- IMC medium containing 100 µg/ml ampicillin (see recipe)
- 10 mg/ml tryptophan (see recipe)
- SDS-PAGE sample buffer (see recipe)
- 30°C convection incubator
- 18 × 50-mm culture tubes
- Roller drum (New Brunswick Scientific)
- 250-ml culture flask
- 70°C water bath
- Microcentrifuge, 4°C
- Additional reagents and equipment for subcloning of DNA fragments (UNIT 3.16), transforming competent *E. coli* cells (UNIT 1.8), preparing miniprep DNA (UNIT 1.6), restriction mapping (UNIT 3.2), direct sequencing of plasmid DNA (UNITS 7.3 & 7.4), SDS-PAGE (UNIT 10.2), and Coomassie brilliant blue staining (UNIT 10.6)

**Construct the *trxA* gene fusion**

1. Use DNA fragment encoding the desired sequence to construct either an in-frame fusion to the 3'-end of the *trxA* gene in pTRXFUS or hpTRXFUS, or a short peptide insertion into the unique *RsrII* site of pALtrxA-781.

*A precise fusion of the desired gene to the enterokinase linker sequence in pTRXFUS or hpTRXFUS can be made by using the unique KpnI site trimmed to a blunt end with the Klenow fragment of E. coli DNA polymerase. The desired gene can usually be adapted to this blunt-end construct by using a synthetic oligonucleotide duplex ligated between it and any convenient downstream restriction site close to the 5' end of the gene. When designing the fusion junction, note that enterokinase is able to cleave —DDDDK↓X—, where X is any amino acid residue except proline. Synthetic oligonucleotides encoding short peptides for insertion into the thioredoxin active-site loop at the RsrII site will insert only in the desired orientation, because the RsrII sticky end consists of three bases.*

2. Transform the ligation mixture containing the new thioredoxin fusion plasmid into competent GI724 cells. Plate transformed cells onto IMC plates containing 100 µg/ml

ampicillin to select transformants. Incubate plates in a 30°C convection incubator until colonies appear.

*Strains GI698, GI723, and GI724 are all healthy prototrophs that can grow under a wide variety of growth conditions, including rich and minimal media and a broad range of growth temperatures (see Table 16.8.1). These strains can be prepared for transformation with pL-containing vectors by growing them in LB medium at 37°C. LB medium may also be used for these strains during the short period of outgrowth immediately following transformation. This growth period of 30 min to 1 hr is often used to express drug resistance phenotypes before plating out plasmid transformations onto solid medium. Subsequently, however, these strains should be grown only on minimal or tryptophan-free rich media, such as IMC medium containing 100 µg/ml ampicillin (for expression of the fusion protein) or CAA/glycerol/ampicillin 100 medium (for plasmid DNA preparations). Except during transformation, LB medium should never be used with these three strains when they carry pL plasmids because LB contains tryptophan. The pL promoter is extremely strong and should be maintained in an uninduced state until needed so that expression of the protein will not lead to selection of mutant or variant cells with lower expression due to undesirable genetic selections or rearrangements in the expression strain.*

3. Grow candidate colonies in 5 ml CAA/glycerol/ampicillin 100 medium overnight at 30°C. Prepare minipreps of plasmid DNA and check for correct gene insertion into pTRXFUS by restriction mapping.
4. Sequence plasmid DNA of candidate clones to verify the junction region between thioredoxin and the gene or sequence of interest.

#### **Induce expression**

5. Streak out frozen stock culture of GI724 containing thioredoxin expression plasmid to single colonies on IMC plates containing 100 µg/ml ampicillin. Grow 20 hr at 30°C.

*Occasionally there is induction of pL plasmids grown in GI698 and GI724 at 37°C, even in medium containing no tryptophan. Such induction appears to be a temperature-dependent phenomenon. If growth at 37°C prior to pL induction is essential, then GI723 should be used as the host strain because GI723 produces higher levels of cI repressor than both GI698 and to GI724. Otherwise, plasmid-containing GI698 should be grown at 25°C and plasmid-containing GI724 should be grown at 30°C prior to induction (see Table 16.8.1).*

6. Pick a single fresh, well-isolated, colony from the plate and use it to inoculate 5 ml IMC medium containing 100 mg/ml ampicillin in an 18 × 150-mm culture tube. Incubate overnight at 30°C on a roller drum.
7. Add 0.5 ml overnight culture to 50 ml fresh IMC medium containing 100 µg/ml ampicillin in a 250-ml culture flask (1:100 dilution). Grow at 30°C with vigorous aeration until absorbance at 550 nm reaches 0.4 to 0.6 OD/ml (~3.5 hr).
8. Remove a 1-ml aliquot of the culture (uninduced cells). Measure the absorbance at 550 nm and harvest the cells by microcentrifuging 1 min at maximum speed, room temperature. Carefully remove all the spent medium with a pipet and store the cell pellet at -80°C.
9. Induce pL by adding 0.5 ml of 10 mg/ml tryptophan (100 µg/ml final) to remaining cells immediately.
10. Incubate 4 hr at 37°C. At hourly intervals during this incubation, remove 1-ml aliquots of the culture and harvest cells as in step 8.

11. Harvest the remaining cells from the culture 4 hr post-induction by centrifuging 10 min at 3000 rpm (e.g., in a Beckman J6 rotor), 4°C. Store the cell pellet at -80°C.

*Procedures for further analysis of these cells are outlined in the support protocols.*

#### **Verify induction**

12. Resuspend the pellets from the induction intervals (steps 8 and 10) in 200 µl of SDS-PAGE sample buffer/OD<sub>550</sub> cells. Heat 5 min at 70°C to completely lyse the cells and denature the proteins. Run the equivalent of 0.15 OD<sub>550</sub> cells per lane (30 µl) on an SDS-polyacrylamide gel.
13. Stain the gel 1 hr with Coomassie brilliant blue. Destain the gel and check for expression.

*Most thioredoxin fusion proteins are produced at levels that vary from 5% to 20% of the total cell protein. The desired fusion protein should exhibit the following characteristics: it should run on the gel at the mobility expected for its molecular weight; it should be absent prior to induction; and it should gradually accumulate during induction, with maximum accumulation usually occurring 3 hr post-induction at 37°C.*

### **SUPPORT PROTOCOL 1**

#### **E. COLI LYSIS USING A FRENCH PRESSURE CELL**

A small 3.5-ml French pressure cell can be used as a convenient way to lyse *E. coli* cells. The whole-cell lysate can be fractionated into soluble and insoluble fractions by microcentrifugation. Other lysis procedures may be used—for example, sonication (UNITS 4.4 & 16.6) or treatment with lysozyme-EDTA (UNIT 4.4).

#### **Additional Materials**

*For recipes, see Reagents and Solutions in this unit (or cross-referenced unit); for common stock solutions, see APPENDIX 2; for suppliers, see APPENDIX 4.*

Cell pellet from 4-hr post-induction culture (basic protocol)

20 mM Tris·Cl, pH 8.0 (APPENDIX 2), 4°C

Lysis buffer: 20 mM Tris·Cl (pH 8.0) with protease inhibitors (optional)—0.5 mM phenylmethylsulfonyl fluoride (PMSF), 1 mM *p*-aminobenzamidine (PABA), and 5 mM EDTA

French press and 3.5-ml mini-cell (Fig. 16.8.2; SLM Instruments), 4°C

#### **Lyse the cells**

1. Resuspend cell pellet from 4-hr post-induction culture in 20 mM Tris·Cl, pH 8.0, to a concentration of 5 OD<sub>550</sub>/ml.

*Protease inhibitors can be included in the resuspension if desired. Cells can also be resuspended at densities of 100 OD<sub>550</sub>/ml or greater; however, at high densities cell lysis may be less efficient.*

2. Place 1.5 ml resuspended cell pellet in the French pressure cell. Hold the cell upside down with the base removed, the piston fully extended downwards, and the outlet valve handle that holds the nylon ball seal in the open position (loose).

*Before filling the pressure cell, check that the nylon ball, which seals the outlet port and sits on the end of the outlet valve handle, is not deformed. If it is, replace it with a new one. Both the condition of the nylon ball and its seat in the pressure cell body are critical for the success of the procedure.*

3. Bring the liquid in the pressure cell to the level of the outlet port by raising the piston slowly to expel excess air from the cell. With the outlet valve open and at the same time maintaining the piston in position, install the pressure cell base. Gently close the outlet valve.

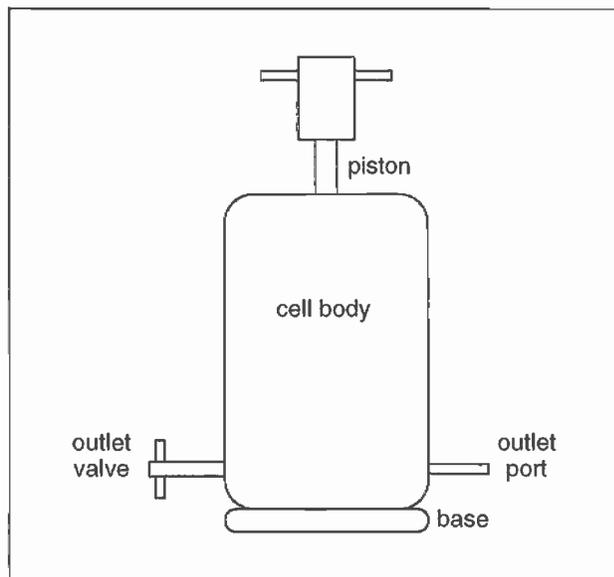

**Figure 16.8.2** French pressure cell, equipped with 3.5-ml mini-cell.

**CAUTION:** Do not over-tighten the valve as this will deform the nylon ball and may irreparably damage its seat on the pressure cell body.

4. Turn the sealed cell right side up and place it in the hydraulic press.
5. Turn the pressure regulator on the press fully counter-clockwise to reset it to zero pressure. Set the ratio selector to medium. Turn on the press.

**CAUTION:** The larger (50-ml) pressure cell is usually used with the selector set on high. The small (3.5-ml) cell is only used on medium ratio.

6. Slowly turn the pressure regulator clockwise until the press just begins to move. Allow the press to compress the piston. It will stop moving after a few seconds.
7. Position a collection tube under the pressure cell outlet. Slowly increase the pressure in the cell by turning the pressure regulator clockwise. Monitor the reading on the gauge and increase the pressure to 1000 on the dial, corresponding to an internal cell pressure of 20,000 lb/in<sup>2</sup>.
8. While continuously monitoring the gauge, very slowly open the outlet valve until lysate begins to trickle from the outlet.

*The lysate should flow slowly and smoothly, and the cell pressure should not drop more than 100 divisions on the dial.*

*At 20,000 lb/in<sup>2</sup> and 5 OD<sub>550</sub>/ml, cell lysis will be complete after one passage through the press. Lower pressures and/or higher cell densities may require a second passage.*

#### **Fractionate the lysate**

9. Remove a 100- $\mu$ l aliquot of the lysate and freeze at  $-80^{\circ}\text{C}$  (whole-cell lysate).
10. Fractionate the remainder of the lysate by microcentrifuging 10 min at maximum speed,  $4^{\circ}\text{C}$ .
11. Remove a 100- $\mu$ l aliquot of the supernatant and freeze at  $-80^{\circ}\text{C}$  (soluble fraction). Discard the remainder of the supernatant.

*Because this is a pilot experiment, it would not produce enough material to warrant saving any remaining supernatant.*

12. Resuspend the pellet in an equivalent volume of lysis buffer. Remove a 100- $\mu$ l aliquot and freeze at  $-80^{\circ}\text{C}$  (insoluble fraction).
13. Lyophilize the 100- $\mu$ l aliquots to dryness in a Speedvac evaporator. Solubilize in 100  $\mu$ l SDS-PAGE sample buffer. Analyze 30- $\mu$ l samples by SDS-PAGE.

*This crude fractionation provides a fairly reliable indication of whether a protein has folded correctly. Usually proteins in the soluble fraction have adopted a correct conformation and proteins in the insoluble fraction have not. However, occasionally proteins found in the soluble fraction are not truly soluble; instead they form aggregates that do not pellet in the microcentrifuge. Conversely, sometimes a protein found in the insoluble fraction may be there because it has an affinity for cell wall components and cell membranes, and it may not be intrinsically insoluble. Occasionally proteins can be recovered from these insoluble fractions by extracting with agents such as mild detergents.*

## SUPPORT PROTOCOL 2

### OSMOTIC RELEASE OF THIOREDOXIN FUSION PROTEINS

Thioredoxin and some thioredoxin fusion proteins can be released with good yield from the *E. coli* cytoplasm by a simple osmotic shock procedure.

#### *Additional Materials*

*For recipes, see Reagents and Solutions in this unit (or cross-referenced unit); for common stock solutions, see APPENDIX 2; for suppliers, see APPENDIX 4.*

Cell pellet from 4-hr post-induction cultures (basic protocol)  
20 mM Tris·Cl (pH 8.0)/2.5 mM EDTA/20% (w/v) sucrose, ice-cold  
20 mM Tris·Cl (pH 8.0)/2.5 mM EDTA, ice-cold

1. Resuspend cell pellet from 4-hr post-induction cultures at a concentration of 5  $\text{OD}_{550}/\text{ml}$  in ice-cold 20 mM Tris·Cl (pH 8.0)/2.5 mM EDTA/20% sucrose. Incubate 10 min on ice.
2. Microcentrifuge 30 sec at maximum speed,  $4^{\circ}\text{C}$ , to pellet the cells.
3. Discard the supernatant and gently resuspend the cells in an equivalent volume of ice-cold 20 mM Tris·Cl (pH 8.0)/2.5 mM EDTA. Incubate 10 min on ice and mix occasionally by inverting the tube.

*Osmotic release from the cytoplasm occurs at this stage.*

4. Microcentrifuge 30 sec at maximum speed,  $4^{\circ}\text{C}$ . Save the supernatant (osmotic shockate). Resuspend the cell pellet in an equivalent volume 20 mM Tris·Cl (pH 8.0)/2.5 mM EDTA (retentate).
5. Lyophilize 100- $\mu$ l aliquots of osmotic shockate and retentate to dryness in a Speedvac evaporator.
6. Solubilize each in 100  $\mu$ l SDS-PAGE sample buffer. Analyze 30- $\mu$ l aliquots by SDS-PAGE.

*The osmotic shock procedure provides a substantial purification step for some thioredoxin fusion proteins. This procedure will remove most of the contaminating cytoplasmic proteins as well as almost all of the nucleic acids. However the shockate will contain as contaminants about half of the cellular elongation factor-Tu (EFTu) and most of the *E. coli* periplasmic proteins.*

## PURIFICATION OF THIOREDOXIN FUSION PROTEINS BY HEAT TREATMENT

Wild-type thioredoxin is resistant to prolonged incubations at 80°C. A subset of thioredoxin fusion proteins also exhibit corresponding thermal stability, and heat treatment at 80°C can sometimes be used as an initial purification step. Under these conditions the majority of contaminating *E. coli* proteins are denatured and precipitated.

### *Additional Materials*

*For recipes, see Reagents and Solutions in this unit (or cross-referenced unit); for common stock solutions, see APPENDIX 2; for suppliers, see APPENDIX 4.*

Cell pellet from 4-hr post-induction cultures (basic protocol)  
20 mM Tris-Cl (pH 8.0)/2.5 mM EDTA  
80°C water bath  
10-ml glass-walled tube

1. Resuspend cell pellet from 4-hr post-induction cultures at a concentration of 100 OD<sub>550</sub>/ml in 20 mM Tris-Cl (pH 8.0)/2.5 mM EDTA.

*It is important to start off with a high protein concentration in the lysate to ensure efficient precipitation of denatured proteins.*

2. Lyse the cells at 20,000 lb/in<sup>2</sup> in a French pressure cell as described in steps 2 to 8 of the first support protocol. Collect whole-cell lysate in a 10-ml glass-walled tube.
3. Incubate whole-cell lysate 10 min at 80°C. Remove 100- $\mu$ l aliquots after 30 sec, 1 min, 2 min and 5 min and plunge immediately into ice. At 10 min plunge the remaining heated lysate into ice.

*A glass-walled tube (not plastic) provides good thermal conductivity to provide a rapid rise in temperature to 80°C and then a rapid drop in temperature to 4°C. A suitable volume to use in a 10-ml glass tube is 1.5 ml lysate. For large-scale work, a glass-walled vessel should be used and the lysate should be mixed well during both heat treatment and cooling.*

4. Microcentrifuge the aliquots 10 min at maximum speed, 4°C to pellet heat-denatured, precipitated proteins.
5. Remove 2- $\mu$ l aliquots of the supernatants and add 28  $\mu$ l SDS-PAGE sample buffer. Analyze the samples by SDS-PAGE to determine the heat stability of the fusion protein and the minimum time of heat treatment required to obtain a good purification.

## REAGENTS AND SOLUTIONS

Use deionized, distilled water in all recipes and protocol steps. For common stock solutions, see APPENDIX 2; for suppliers, see APPENDIX 4.

### **Casamino Acids (CAA), 2% (w/v)**

20 g Casamino Acids (Difco certified)  
H<sub>2</sub>O to 1 liter  
Autoclave or filter sterilize through a 0.45- $\mu$ m filter  
Store  $\leq$ 2 months at room temperature

*Do not use technical-grade Casamino Acids because it has a higher NaCl content.*

### **CAA/glycerol/ampicillin 100 medium**

800 ml 2% (w/v) Casamino Acids (see recipe; 1.6% final)  
100 ml 10 $\times$  M9 salts (see recipe; 1 $\times$  final)  
100 ml 10% (v/v) glycerol (sterile; 1% final)  
1 ml 1 M MgCl<sub>2</sub> (sterile; 1 mM final)  
0.1 ml 1 M CaCl<sub>2</sub> (sterile; 0.1 mM final)  
1 ml 2% (w/v) vitamin B1 (sterile; 0.002% final)  
10 ml 10 mg/ml ampicillin (sterile; 100  $\mu$ g/ml final)  
Prepare fresh

### **IMC medium**

200 ml 2% (w/v) Casamino Acids (see recipe; 0.4% final)  
100 ml 10 $\times$  M9 salts (see recipe; 1 $\times$  final)  
40 ml 20% (w/v) glucose (sterile; 0.5% final)  
1 ml 1 M MgCl<sub>2</sub> (sterile; 1 mM final)  
0.1 ml 1 M CaCl<sub>2</sub> (sterile; 0.1 mM final)  
1 ml 2% (w/v) vitamin B1 (sterile; 0.002% final)  
658 ml glass-distilled H<sub>2</sub>O (sterile)  
10 ml 10 mg/ml ampicillin (sterile; optional; 100  $\mu$ g/ml final)  
Use fresh

### **IMC plates**

15 g agar [Difco; 1.5% (w/v)]  
4 g casamino acids [Difco-certified; 0.4% (w/v)]  
858 ml glass-distilled H<sub>2</sub>O (sterile)  
Autoclave 30 min  
Cool in a 50°C water bath  
100 ml 10 $\times$  M9 salts (see recipe; 1 $\times$  final)  
40 ml 20% (w/v) glucose (sterile; 0.5% final)  
1 ml 1 M MgCl<sub>2</sub> (sterile; 1 mM final)  
0.1 ml 1 M CaCl<sub>2</sub> (sterile; 0.1 mM final)  
1 ml 2% (w/v) vitamin B1 (sterile; 0.002% final)  
10 ml 10 mg/ml ampicillin (sterile; optional; 100  $\mu$ g/ml final)  
Mix well and pour into Petri plates  
Store  $\leq$ 1 month at 4°C

### **M9 salts, 10 $\times$**

60 g Na<sub>2</sub>HPO<sub>4</sub> (0.42 M)  
30 g KH<sub>2</sub>PO<sub>4</sub> (0.24 M)  
5 g NaCl (0.09 M)  
10 g NH<sub>4</sub>Cl (0.19 M)  
H<sub>2</sub>O to 1 liter

*continued*

Adjust pH to 7.4 with NaOH  
Autoclave or filter sterilize through a 0.45- $\mu$ m filter  
Store  $\leq$ 6 months at room temperature

#### **SDS-PAGE sample buffer**

15% (v/v) glycerol  
0.125 M Tris-Cl, pH 6.8 (APPENDIX 2)  
5 mM Na<sub>2</sub>EDTA  
2% (w/v) SDS  
0.1% (w/v) bromphenol blue  
1% (v/v) 2-mercaptoethanol (2-ME; add immediately before use)  
Store indefinitely at room temperature

#### **Tryptophan, 10 mg/ml**

Heat 500 ml glass-distilled H<sub>2</sub>O to 80°C. Stir in 5 g L-tryptophan until dissolved. Filter sterilize the solution through a 0.45  $\mu$ m filter and store  $\leq$ 6 months in the dark at 4°C.

## COMMENTARY

### **Background Information**

Two significant problems plague researchers who hope to express heterologous proteins in *Escherichia coli*: inefficient initiation of translation of many eukaryotic mRNA sequences on bacterial ribosomes (Stormo et al., 1982), and proteins that often form insoluble aggregates, called inclusion bodies, that are composed of misfolded or denatured proteins (Mitraki and King, 1989). Although successful protocols for refolding eukaryotic proteins from inclusion bodies can be developed, the process is always uncertain and usually time-consuming; in most instances it is preferable to prevent inclusion-body formation in the first place. The use of *trxA* fusions provides a solution to both problems.

Inefficient initiation of translation of eukaryotic messages in *E. coli* can often be improved by modifying sequences at the 5' end of the gene. A more reliable technique that avoids the problem entirely is to use a gene fusion strategy in which the gene of interest is linked in-frame to the 3' end of a highly translated partner gene. In this case protein synthesis always initiates on the same efficiently translated fusion partner mRNA, thus high-level expression is assured. Some earlier gene fusion expression systems, for example the *trpE* and *lacZ* systems described in UNIT 16.5, offer very reliable ways of producing large quantities of any desired eukaryotic protein. However, these gene fusion systems still suffer from the pervasive inclusion-body problem. They are thus mainly useful for the production of antigens, rather than correctly folded, biologically active proteins. More recently the maltose binding

protein (MBP) and glutathione-S-transferase (GST) gene fusion expression systems (see UNITS 16.6 & 16.7) have proven more successful in producing soluble fusion proteins; these systems retain the translation advantage of the earlier fusion systems. Apart from the obvious advantages in making a correctly folded product, the synthesis of soluble fusion proteins also allows for the development of generic purification schemes based on some unique property of the fusion partner.

Why would any particular eukaryotic protein produced in the *E. coli* cytoplasm be more soluble when it is linked to a fusion partner than it would be by itself? It is likely that physical properties of the fusion partner protein are important, with efficient self-folding and high solubility being useful in this role. It is possible that some good fusion partners (proteins that fold efficiently and are highly soluble), by virtue of their desirable physical qualities, are able to keep folding intermediates of linked heterologous proteins in solution long enough for them to adopt their correct final conformations. In this respect the fusion partner may serve as a covalently joined chaperon protein, in many ways fulfilling the role of authentic chaperon proteins (McCoy, 1992), analogous to the covalent chaperon role proposed for the N-terminal pro regions of a number of protein precursors (Silen et al., 1989; Shinde et al., 1993).

Many of the known properties of *E. coli* thioredoxin (Holmgren, 1985) suggested that it would make a particularly effective fusion partner in an expression system. First, thioredoxin, when overproduced from plasmid vec-

tors, can accumulate to 40% of the total cellular protein, yet even at these expression levels all of the protein remains soluble. Second, the molecule is small (11,675 M<sub>r</sub>) and would contribute a relatively modest amount to the total mass of any fusion protein, in contrast to other systems such as the *lacZ* system. Third, the tertiary structure of thioredoxin (Katti et al., 1990) reveals that both the N- and C-termini of the molecule are accessible on the surface and in good position to link to other proteins. The structure also shows that the molecule has a very tight fold, with >90% of its primary sequence involved in strong elements of secondary structure. This provides an explanation for thioredoxin's observed high thermal stability ( $T_m$  85°C), and suggests that the molecule might possess the robust folding characteristics that could make it a good fusion partner protein. In support of this view, complete thioredoxin domains are found in a number of naturally occurring multidomain proteins, including *E. coli* DsbA (Bardwell et al., 1991), the mammalian endoplasmic reticulum proteins ERp72 (Mazzarella et al., 1990), and protein disulfide isomerase (PDI; Edman et al., 1985). These proteins can all be considered as natural precedents for thioredoxin fusion proteins.

The synthesis of small peptides in *E. coli* is often difficult, with the products frequently being extensively degraded or insoluble. The thioredoxin tertiary structure revealed that the characteristic active site, —CGPC—, protrudes from the body of the protein as a surface loop, with few interactions with the rest of the molecule. The loop does not seem to contribute to the overall stability of thioredoxin, so the production of peptides as insertions at this site was an attractive possibility. In this location they would be protected from host-cell amino- and carboxypeptidases, and thioredoxin's high solubility should help keep them in solution. In addition, the conformation of peptides inserted at this position would be constrained, which could be an advantage for applications in which it is desirable for the peptide to adopt a particular form.

Thioredoxin has indeed proven to be an excellent partner for the production of soluble fusion proteins in the *E. coli* cytoplasm (LaVallie et al., 1993b). Figure 16.8.3 demonstrates the production of soluble fusion proteins between thioredoxin and eleven human and murine cytokines and growth factors using the *trx*A vectors. All of these mammalian proteins had been previously produced in *E. coli* only

as insoluble inclusion bodies. As thioredoxin fusions, the growth factors are not only made in a soluble form, but in most cases they are also biologically active in *in vitro* assays.

Experience gained while working with these and a number of other *trx*A fusion proteins shows that two further characteristics of thioredoxin can be exploited as purification tools. The first is the inherent thermal stability of the molecule, a property that is retained by some thioredoxin fusion proteins. This enables heat treatment to be used as an effective purification step. The second additional property relates to thioredoxin's cellular location. Although *E. coli* thioredoxin is a cytoplasmic protein, it has been shown to occupy a special position within the cell—it is primarily located on the cytoplasmic face of the adhesion zones that exist between the inner and outer membranes of the *E. coli* cell envelope (Lunn and Pigiet, 1982). From this location thioredoxin is quantitatively released to the exterior of the cell by simple osmotic shock or freeze/thaw treatments, a remarkable property that is retained by some thioredoxin fusion proteins, thus providing a simple purification step.

A more generic method for purification of any soluble thioredoxin fusion employs a modified form of thioredoxin (called "His-patch Trx"), which has been designed to bind to metal chelate resins (E.A. DiBlasio, J.M. McCoy, and E.R. LaVallie, manuscript in preparation).

### Critical Parameters

Lack of protein solubility leading to inclusion-body formation in *E. coli* is a complex phenomenon with many contributing factors: simple insolubility as a result of high-level expression, insolubility of protein-folding intermediates, lack of appropriate bacterial chaperon proteins, and lack of glycosylation mechanisms in the bacterial cytoplasm. Fusion of heterologous proteins to thioredoxin or to other fusion partners can help address most of these solubility issues. However, another important factor contributing to inclusion body formation is the inability to form essential disulfide bonds in the reducing environment of the bacterial cytoplasm, which leads to incorrect folding. Thermal lability of even correctly folded heterologous proteins in the absence of these stabilizing disulfide cross-links is a significant problem, so the expression of fusion genes should be attempted over a wide range of temperatures, even as low as 15°C (the limit for *E. coli* growth is ~8°C). Thermal denaturation is

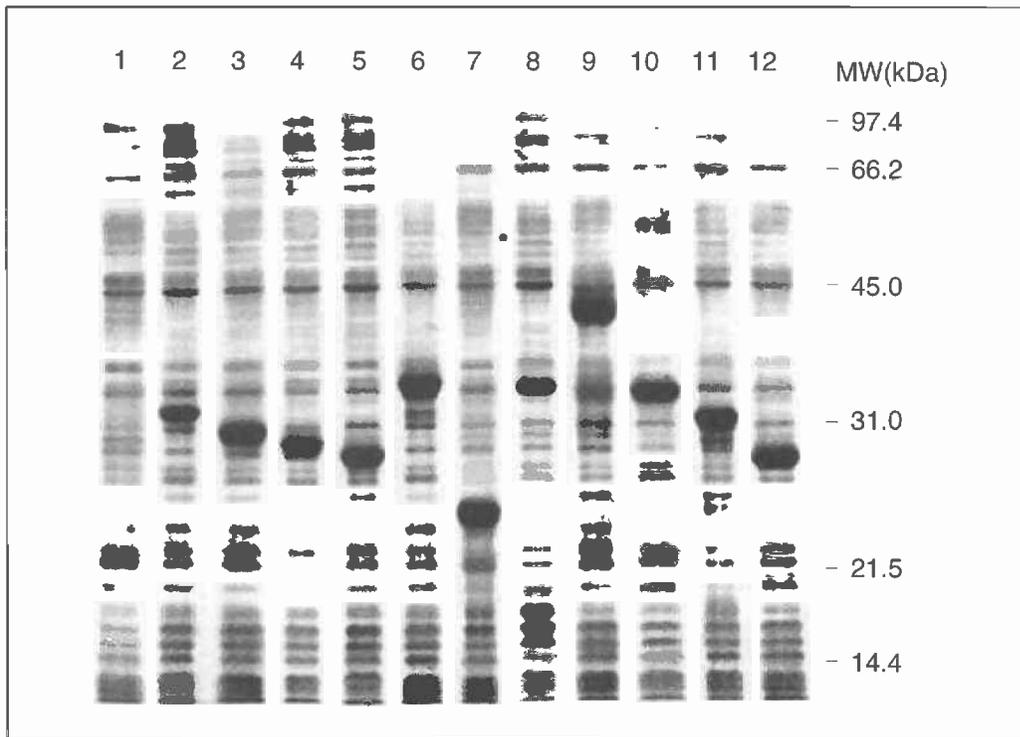

**Figure 16.8.3** Expression of thioredoxin gene fusions. The gel shows proteins found in the soluble fractions derived from *E. coli* cells expressing eleven different thioredoxin gene fusions. Lane 1, host *E. coli* strain GI724 (negative control, 37°C); lane 2, murine interleukin-2 (IL-2; 15°C); lane 3, human IL-3 (15°C); lane 4, murine IL-4 (15°C); lane 5, murine IL-5 (15°C); lane 6, human IL-6 (25°C); lane 7, human MIP-1a (37°C); lane 8, human IL-11 (37°C); lane 9, human macrophage colony-stimulating factor (M-CSF; 37°C); lane 10, murine leukemia inhibitory factor (LIF; 25°C); lane 11, murine steel factor (SF; 37°C); and lane 12, human bone morphogenetic protein-2 (BMP-2; 25°C). Temperatures in parentheses are the production temperature chosen for expressing each fusion. This is a 10% SDS-polyacrylamide gel, stained with Coomassie brilliant blue.

a time-dependent process, so it is also prudent to monitor the solubility of the expressed fusion protein over the time course of induction.

A great many proteins contain distinct structural domains. For example, hormone receptor proteins usually have an extracellular ligand-binding domain, a transmembrane region, and an intracellular effector domain. Sometimes expressing these domains individually as fusion proteins can yield better results than expressing the entire protein. The exact positions chosen for boundaries of the domains to be expressed in the fusion protein are important and can be determined from a knowledge of the tertiary structure of the protein of interest, by homology comparisons with similar proteins, by limited proteolysis or other domain-mapping experiments, or empirically by generating multiple fusions that test different boundary positions.

It is important to be consistent in treating samples for loading on gels. For example, using different heating conditions from one experi-

ment to the next can result in a mobility shift for the protein of interest.

### Anticipated Results

Thioredoxin fusion protein yields are usually in the range of 5% to 20% of total cell protein. At these expression levels a 1-liter induction culture in a shaker flask will yield ~3 g (wet weight) of cells, 300 mg total protein, and 15 to 60 mg of thioredoxin fusion protein. The final recovered yield will depend on factors such as solubility of the fusion protein and the efficiency of downstream purification procedures.

### Time Considerations

From a single colony on a plate, the basic induction protocol requires an overnight growth to prepare a liquid inoculum and a 3.5-hr preinduction growth at 30°C the next day, followed by a 4-hr 37°C induction period. These times are significantly longer if lower induction temperatures are required (see Table

16.8.1). Lysis of a sample in the French pressure cell should require  $\leq 5$  min, and both the heat-treatment and osmotic-shock procedures require  $<1$  hr each. SDS-PAGE takes 2.5 hr.

### Literature Cited

- Bardwell, J.C.A., McGovern, K., and Beckwith, J. 1991. Identification of a protein required for disulfide bond formation in vivo. *Cell* 67:581-589.
- Edman, J.C., Ellis, L., Blacher, R.W., Roth, R.A., and Rutter, W.J. 1985. Sequence of protein disulphide isomerase and implications of its relationship to thioredoxin. *Nature* 317:267-270.
- Holmgren, A. 1985. Thioredoxin. *Ann. Rev. Biochem.* 54:237-271.
- Katti, S.K., LeMaster, D.M., and Eklund, H. 1990. Crystal structure of thioredoxin from *Escherichia coli* at 1.68 angstroms resolution. *J. Mol. Biol.* 212:167-184.
- LaVallie, E.R., Rehemtulla, A., Racie, L.A., DiBlasio, E.A., Ferenz, C., Grant, K.L., Light, A., and McCoy, J.M. 1993a. Cloning and functional expression of a cDNA encoding the catalytic subunit of bovine enterokinase. *J. Biol. Chem.* 268:23311-23317.
- LaVallie, E.R., DiBlasio, E.A., Kovacic, S., Grant, K.L., Schendel, P.F., and McCoy, J.M. 1993b. A thioredoxin gene fusion expression system that circumvents inclusion body formation in the *E. coli* cytoplasm. *Bio/Technology* 11:187-193.
- Lunn, C.A. and Pigiet, V.P. 1982. Localization of thioredoxin from *Escherichia coli* in an osmotically sensitive compartment. *J. Biol. Chem.* 257:11424-11430.
- Mazzarella, R.A., Srinivasan, M., Haugejorden, S.M., and Green, M. 1990. ERp72, an abundant luminal endoplasmic reticulum protein, contains three copies of the active site sequences of protein disulfide isomerase. *J. Biol. Chem.* 265:1094-1101.
- McCoy, J.M. 1992. Heat-shock proteins and their potential uses for pharmaceutical protein production in microorganisms. In *Stability of Protein Pharmaceuticals, Part B.* (T. Ahern and M. Manning, eds.) pp 287-316. Plenum Press, New York.
- Mieschendahl, M., Petri, T., and Hanggi, U. 1986. A novel prophage independent trp regulated lambda pL expression system. *Bio/Technology* 4:802-808.
- Mitraki, A. and King, J. 1989. Protein folding intermediates and inclusion body formation. *Bio/Technology* 7:690-697.
- Norrander, J., Kempe, T., and Messing, J. 1983. Construction of improved M13 vectors using oligonucleotide-directed mutagenesis. *Gene* 26:101-106.
- Shimatake, H. and Rosenberg, M. 1981. Purified  $\lambda$  regulatory protein cII positively activates promoters for lysogenic development. *Nature* 292:128-132.
- Shinde, U., Chatterjee, S., and Inouye, M. 1993. Folding pathway mediated by an intramolecular chaperone. *Proc. Natl. Acad. Sci. U.S.A.* 90:6924-6928.
- Silen, J.L., Frank, D., Fujishige, A., Bone, R., and Agard, D.A. 1989. Analysis of prepro- $\alpha$ -lytic protease expression in *Escherichia coli* reveals that the pro region is required for activity. *J. Bacteriol.* 171:1320-1325.
- Stormo, G.D., Schneider, T.D., and Gold, L. 1982. Characterization of translation initiation sites in *E. coli*. *Nucl. Acids Res.* 10:2971-2996.

---

Contributed by John McCoy  
and Edward LaVallie  
Genetics Institute  
Cambridge, Massachusetts

# EXPRESSION OF PROTEINS IN INSECT CELLS USING BACULOVIRUS VECTORS

## Overview of the Baculovirus Expression System

Baculoviruses have emerged as a popular system for overproducing recombinant proteins in eukaryotic cells (Luckow and Summers, 1988; Miller et al., 1986; Miller, 1988; Luckow, 1991). Several factors have contributed to this popularity. First, unlike bacterial expression systems, the baculovirus-based system is a eukaryotic expression system and thus uses many of the protein modification, processing, and transport systems present in higher eukaryotic cells. In addition, the baculovirus expression system uses a helper-independent virus that can be propagated to high titers in insect cells adapted for growth in suspension cultures, making it possible to obtain large amounts of recombinant protein with relative ease. The majority of this overproduced protein remains soluble in insect cells, in contrast to the insoluble proteins often obtained from bacteria. Furthermore, the viral genome is large (~130 kbp) and thus can accommodate large segments of foreign DNA. Finally, baculoviruses are non-infectious to vertebrates, and their promoters have been shown to be inactive in most mammalian cells (Carbonell et al., 1985), which gives them a possible advantage over other systems when expressing oncogenes or potentially toxic proteins.

This unit gives an overview of the baculovirus expression system. A comprehensive guide describing further details can be found in O'Reilly et al. (1992).

### BACULOVIRUS LIFE CYCLE

Currently, the most widely used baculovirus expression system utilizes a lytic virus known as *Autographa californica* nuclear polyhedrosis virus (AcMNPV; hereafter called baculovirus). This virus is the prototype of the family *Baculoviridae*. It is a large, enveloped, double-stranded DNA virus that infects arthropods. The baculovirus expression system takes advantage of some unique features of the viral life cycle (Fig. 16.9.1). See Doerfler and Bohm (1986) for a comprehensive review.

As with mammalian DNA viruses, the bacu-

lovirus life cycle is divided temporally into immediate early, early, late, and very late phases. Viruses enter the cell by adsorptive endocytosis and move to the nucleus, where their DNA is released. DNA replication begins ~6 hr after infection and is followed by viral assembly in the nucleus of the infected cell. Two types of viral progeny are produced during the life cycle of the virus: extracellular virus particles (nonoccluded viruses) during the late phase and polyhedra-derived virus particles (occluded viruses) during the very late phase of infection. Extracellular virus is released from the cell by budding, beginning at ~12 hr postinfection, and is produced at a logarithmic rate until 20 hr postinfection, after which production drops off. Polyhedra-derived virus, on the other hand, appears in the nucleus at ~18 hr postinfection and continues to accumulate as late as 72 hr postinfection, or until the cells lyse. Occluded viral particles are embedded in proteinaceous viral occlusions called polyhedra within the nucleus of infected cells. The polyhedrin protein (29 kDa) is the major protein component of the occlusion bodies.

The polyhedrin protein serves an important function for the survival and propagation of the virus in nature. Because baculoviruses are lytic, they quickly kill their insect host after infection. The polyhedrin protein serves to sequester, and thereby protect, hundreds of virus particles from proteolytic inactivation by the decomposing host tissue. The virus is transmitted when occlusion bodies are ingested by a new host as it feeds on a contaminated food source. The polyhedrin protein dissolves in the alkaline environment of the new host's gut and the occluded virus is released. This virus infects the gut epithelial cells and virus replication takes place. Nonoccluded virus is then produced and budded from the infected gut cells. At this point, the virus spreads throughout the tissues of its new host. Although the polyhedrin protein is essential for survival of the virus in nature, it is dispensable for virus survival and propagation in tissue culture cells.

## BACULOVIRUS EXPRESSION SYSTEM

The baculovirus expression system takes advantage of several facts about polyhedrin protein: (1) that it is expressed at very high levels in infected cells, constituting more than half of the total cellular protein late in the infectious cycle; (2) that it is nonessential for infection and replication of the virus, meaning that the recombinant virus does not require any helper function; and (3) that viruses lacking the polyhedrin gene have a plaque morphology that is distinct from that of viruses containing the gene. Recombinant baculoviruses are generated by replacing the polyhedrin gene with a foreign gene through homologous recombina-

tion. In this system, the distinctive plaque morphology provides a simple visual screen for identifying the recombinants.

To produce a recombinant virus that expresses the gene of interest, the gene is first cloned into a transfer vector (see discussion below under Choosing a Baculovirus Transfer Vector). Most baculovirus transfer vectors contain the polyhedrin promoter followed by one or more restriction enzyme recognition sites for foreign gene insertion. Once cloned into the transfer vector, the gene is flanked both 5' and 3' by viral-specific sequences. Next, the recombinant vector is transfected along with wild-type viral DNA into insect cells. In a homologous recombination event, the foreign gene is

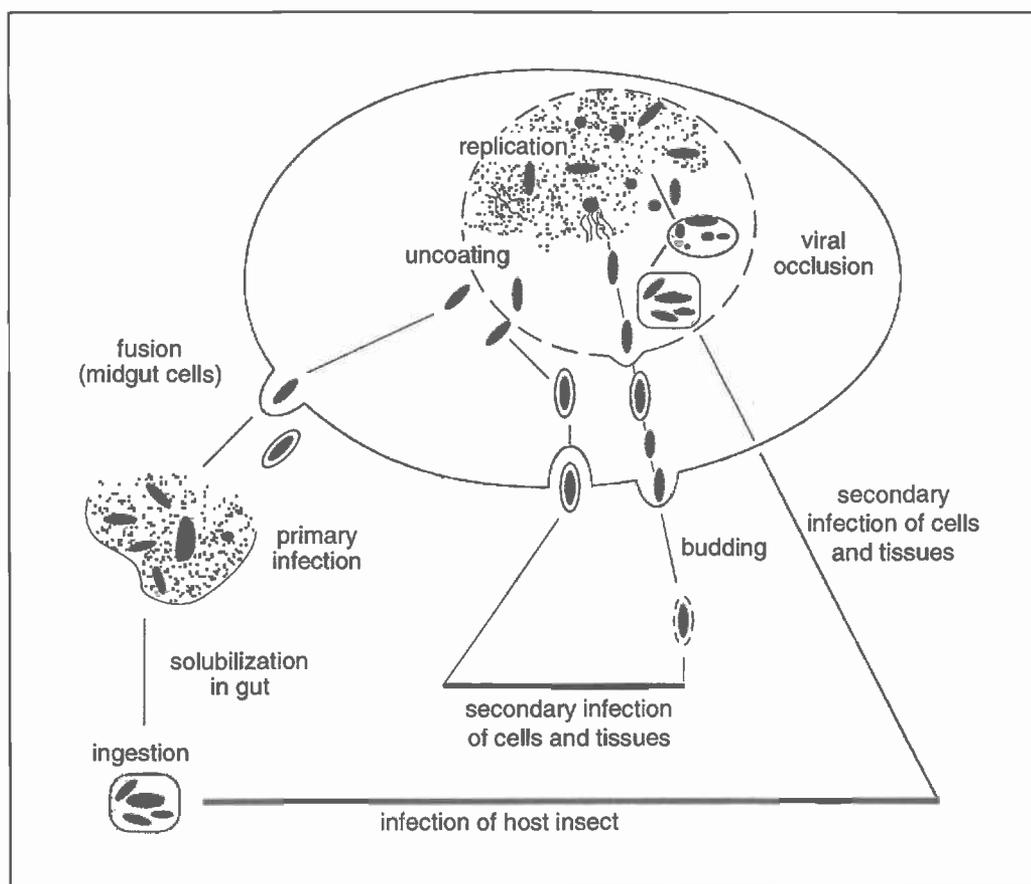

**Figure 16.9.1** Baculovirus life cycle. Viruses enter cells by adsorptive endocytosis and move to the nucleus where their DNA is released. Both DNA replication and viral assembly take place in the nuclei of infected cells to generate two types of viral progeny. These include extracellular (nonoccluded) virus particles and polyhedra-derived (occluded) virus particles. Extracellular virus is released from the cell by budding, starting at ~12 hr postinfection and ending ~36 hr postinfection. Polyhedra-derived virus, on the other hand, appears later (~18 hr postinfection) and accumulates in the nuclei of infected cells ≤72 hr postinfection or until cellular lysis. Polyhedra-derived virus is embedded in proteinaceous viral occlusions, the major protein component of which is the viral polyhedrin protein. Secondary infection of cells and tissues occurs by two pathways. In the first, the extracellular virus, once budded from the site of primary infection, is free to infect neighboring cells by the pathway just described. Alternatively, polyhedra-derived virus is released from occlusion bodies after an infected food source is ingested by a new host. Reproduced from Summers and Smith (1987) with permission from the Texas Agricultural Experiment Station.

inserted into the viral genome and the polyhedrin gene is replaced. Thus recombinant viruses lack the polyhedrin gene and in its place contain the inserted gene, whose expression is under the control of the polyhedrin promoter.

Homologous recombination between circular wild-type DNA and the recombinant plasmid DNA occurs at a low frequency (typically 0.1% to 0.5%). This limitation was recently overcome by the development of viruses having *Bsu*36I restriction sites positioned within an essential gene—*Open Reading Frame (ORF) 1629*—which is downstream of the AcMNPV polyhedrin gene—and also in the upstream *ORF 603*—in such a way that digestion releases a fragment containing a sequence necessary for virus growth (Kitts and Possee, 1993). When insect cells are cotransfected with an appropriate recombinant transfer plasmid and linearized *ORF 1629*-deleted baculovirus DNA, the necessary *ORF 1629* is provided by the transfer plasmid through homologous recombination. The vast majority of the progeny viruses, in many cases >99.9%, that are derived from these cotransfections contain the repaired virus with the target gene, thus minimizing the need to screen and plaque-purify recombinants. Several companies (PharMingen, Invitrogen, Clontech, and Novagen; see APPENDIX 4) market linearized *ORF 1629*-deleted AcMNPV DNA. To further facilitate the identification of recombinants, several of these commercially available baculovirus DNAs contain the bacterial *lacZ* gene, which codes for  $\beta$ -galactosidase in lieu of the AcMNPV polyhedrin gene, thereby allowing *lacZ*-negative recombinants to be distinguished visually from any residual nonrecombinant viruses via a plaque assay. Nonrecombinant viruses form blue plaques on Xgal plates because they contain a functional *lacZ* gene, whereas recombinants form colorless, opaque plaques. Recombinant viruses can also be identified by DNA hybridization and polymerase chain reaction (PCR) amplification.

Another rapid and efficient method for generating recombinant baculoviruses uses site-specific transposition to insert foreign genes by homologous recombination into a bacmid propagated in *E. coli* rather than in insect cells. In this case, recombinant viral DNA is isolated from individual bacterial colonies and is free of any wild-type viral DNA. Upon transfection of insect cells, recombinant virus is generated free of parental nonrecombinant virus, thereby eliminating the need for multiple rounds of plaque purification. This is the basis of the BAC-TO-BAC baculovirus expression system,

which is available commercially from Life Technologies.

## POSTTRANSLATIONAL MODIFICATION OF PROTEINS IN INSECT CELLS

Because baculoviruses infect invertebrate cells, it is possible that the processing of proteins produced by them is different from the processing of proteins produced by vertebrate cells. Although this seems to be the case for some posttranslational modifications, it is not the case for others. For example, two of the three posttranslational modifications of the tyrosine protein kinase, pp60<sup>c-src</sup>, that occur in higher eukaryotic cells (myristylation and phosphorylation of serine 17) also take place in insect cells. However, another modification of pp60<sup>c-src</sup> observed in vertebrate cells, phosphorylation of tyrosine 527, is almost undetectable in insect cells (Piwnicka-Worms et al., 1990).

In addition to myristylation, palmitylation has been shown to take place in insect cells. However, it has not been determined whether all or merely a subfraction of the total recombinant protein contains these modifications. Cleavage of signal sequences, removal of hormonal prosequences, and polyprotein cleavages have also been reported, although cleavage varies in its efficiency. Internal proteolytic cleavages at arginine- or lysine-rich sequences have been reported to be highly inefficient, and alpha-amidation, although it does not occur in cell culture, has been reported in larvae and pupae (Hellers et al., 1991). In most of these cases a cell- or species-specific protease may be necessary for cleavage. Protein targeting seems conserved between insect and vertebrate cells. Thus, proteins can be secreted and localized faithfully to either the nucleus, cytoplasm, or plasma membrane. Although much remains to be learned about the nature of protein glycosylation in insect cells, proteins that are glycosylated in vertebrate cells will also generally be glycosylated in insect cells. However, with few exceptions the N-linked oligosaccharides in insect cell-derived glycoproteins are only high-mannose type and are not processed to complex-type oligosaccharides containing fucose, galactose, and sialic acid. O-linked glycosylations have been even less well characterized in *Sf9* cells, but have been shown to occur. For further information on posttranslational modifications of proteins and protein processing in insect cells, see Davidson et al. (1990), O'Reilly et al. (1992), Jarvis and Sum-

mers (1992), Grabenhorst et al. (1993), James et al. (1995), Jarvis and Finn (1995), Davis and Wood (1995), and Ogonah et al. (1996).

## STEPS FOR OVERPRODUCING PROTEINS USING THE BACULOVIRUS SYSTEM

The use of the baculovirus expression system is presented in detail in *UNIT 16.10 & 16.11*. The following steps comprise a brief overview (also see Fig. 16.9.2).

1. Clone the gene of interest into the appropriate baculovirus expression vector and cotransfect with linearized baculoviral DNA (available from various vendors). Alternatively, purify circular wild-type baculovirus DNA (*UNIT 16.10*, Alternate Protocol 1).

2. Cotransfect baculovirus DNA with the recombinant baculovirus plasmid into *Sf9* insect cells (*UNIT 16.10*, Basic Protocol 2).

3. Collect the medium, which contains the baculoviral particles (*UNIT 16.10*, Basic Protocol 2), and plaque the virus on *Sf9* cells to separate recombinant from nonrecombinant virus (*UNIT 16.10*, Basic Protocol 4). This and subsequent rounds of plaque purification are optional when linearized virus that contains a lethal deletion is used (e.g., BaculoGold from Pharmingen), as in that case >99.9% of all amplified virus particles will be recombinant because of selection pressure.

4. Amplify the virus stock by infecting fresh insect cells (*UNIT 16.10*, Basic Protocol 3) and determine titer of the amplified virus stock (*UNIT 16.10*, Basic Protocol 4).

5. Express the protein of interest by infecting a new batch of insect cells with the high-titer baculovirus stock (*UNIT 16.11*, Basic Protocol 1). Determine the expression level of the recombinant protein of interest and analyze its biological activity (*UNIT 16.11*, Support Protocols 1 & 2).

## CHOOSING A BACULOVIRUS TRANSFER VECTOR

The majority of available baculovirus vectors are pUC-based and confer ampicillin resistance. Most contain the polyhedrin gene promoter and insertion site(s) for cloning a foreign gene of interest, flanked by viral sequences that lie 5' to the promoter and 3' to the foreign gene insert. These flanking sequences facilitate homologous recombination between the vector and baculovirus DNA. Other baculovirus vectors contain the p10 promoter, another strong, very late promoter, or the basic protein promoter expressed late in the infection process. Some vectors are designed to express more than

one heterologous gene or to express genes as fusions to N-terminal signal sequences or leader peptides, which facilitate secretion and purification of the recombinant protein. For more information on these vectors, see Table 16.9.1, O' Reilly et al. (1992), and relevant catalogs from Pharmingen, Clontech, Invitrogen, Novagen, Life Technologies, and Stratagene.

A major consideration when choosing the appropriate baculovirus expression vector is whether to express the recombinant protein as a fusion or nonfusion protein in insect cells. Fusion proteins containing a specific tag have the advantage of easy purification and detection. For nonfusion proteins, there are several vectors available—notably pVL1392 and pVL1393 (Pharmingen and Invitrogen)—each of which contains a polylinker in the opposite orientation from the other. These vectors are derived from pAcYM1 (Matsuura et al., 1987) and pAcCL29 (Livingston and Jones, 1989) and differ only in the order of the cloning sites. Other nonfusion vectors include pBacPAK8 and pBacPAK9 (Clontech), pBac-1 (Novagen), and pAcSG2 (Pharmingen). To express the protein as a polyhistidine fusion protein, there are several available vectors: pAcHLT-A, -B, and -C (Pharmingen), pBlueBacHis-A, -B, and -C (Invitrogen), and pBac-2cp (Novagen). These vectors allow easy purification of the recombinant protein using a nickel-chelating resin (*UNIT 10.11B*). To express the protein as a glutathione-S-transferase (GST) fusion protein, the pAcGHLT-A, -B, and -C vectors are commercially available (Pharmingen). These produce an N-terminal GST fusion protein. As with all fusion protein vectors, the gene of interest has to be cloned in the proper reading frame with respect to the tag.

Secretion of recombinant proteins into insect cell medium simplifies purification and characterization of expressed recombinant proteins. The ease of purification is further enhanced by the use of serum-free medium. There are several vectors that contain signal sequences under strong polyhedrin-promoter control that direct the nascent polypeptide chain toward the secretory pathway of the cell. The sequences to be expressed are inserted downstream with respect to the signal sequences to generate a fusion gene that is transcribed under strong polyhedrin-promoter control. The secretion of biologically active protein from insect cells is the final step in a complex pathway of posttranslational modifications performed in the endoplasmic reticulum (ER)

and the Golgi complex (GC). Proteins destined for secretion are first cotranslationally translocated into the lumen of the ER, where initial steps of carbohydrate processing occur. Later, the protein is transported to the GC, where further modifications take place. During

translocation, the amino-terminal leader peptide sequence is, in most cases, proteolytically removed. The major determinants for the final form of posttranslational modification of a protein are its primary structure and the conformation presented to successive processive steps.

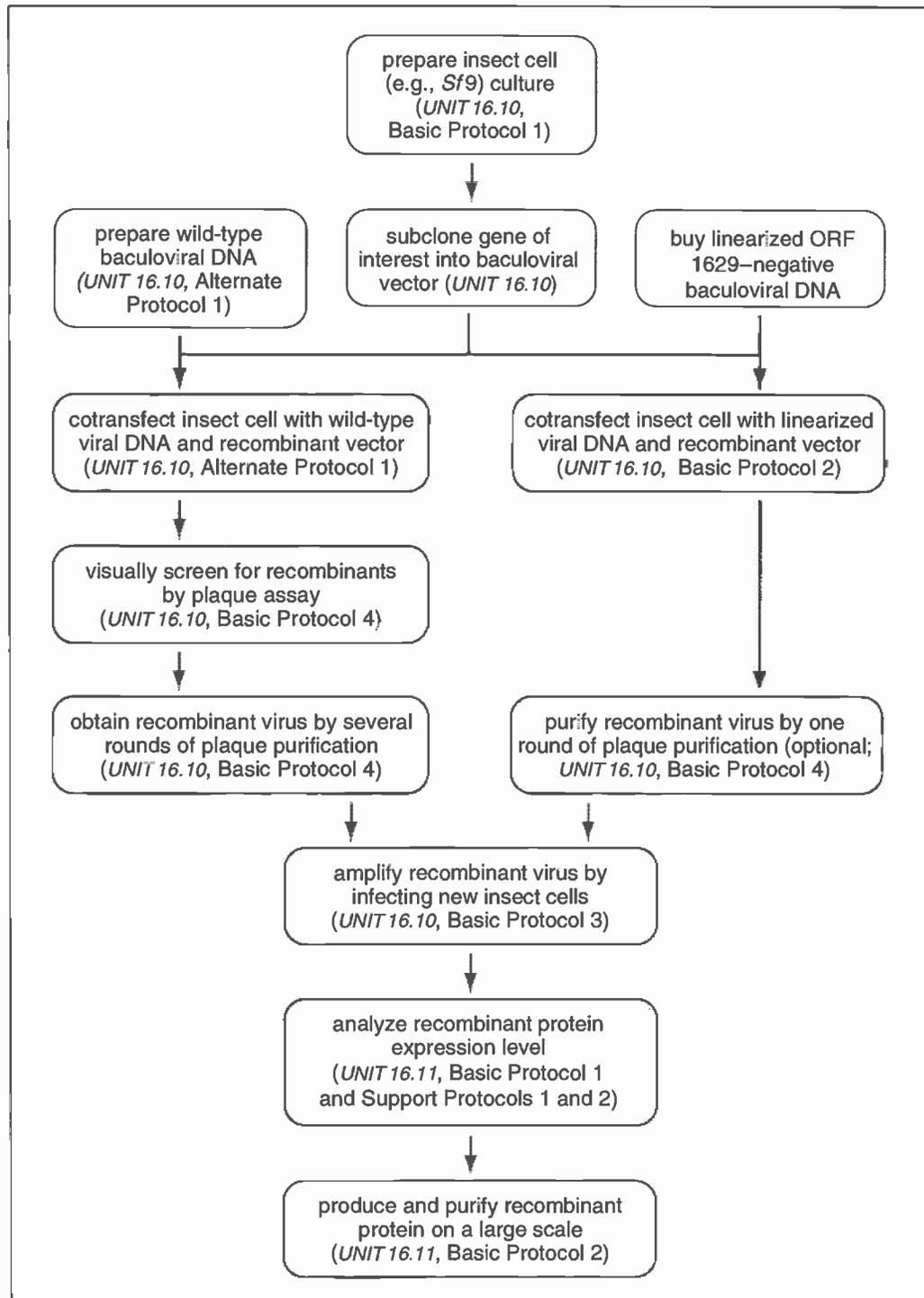

**Figure 16.9.2** Flow chart for the expression of proteins in insect cells using the baculovirus system. The flow chart describes the production of recombinants using circular wild-type baculovirus DNA and the more recently developed linearized *ORF 1629*-negative variants. The use of linearized baculovirus DNA, now widely accepted, simplifies the whole protocol and produces viral-infection stocks with little or no background of nonrecombinants, which may be used directly without plaque purification.

**Table 16.9.1** Baculoviral Expression Vectors<sup>a</sup>

Vector	Promoter	Promoter type	Fusion protein	Features	Source <sup>b</sup>
<b>Polyhedrin locus–based</b>					
<i>Single-baculovirus promoter vectors</i>					
pVL1392/1393 (pair)	P	VL	No	Standard transfer vectors	PG, IN
pAcSG2	P	VL	— <sup>c</sup>	Recommended for large inserts	PG
pAcMP2/3 (pair)	BP	L	No	Facilitates post-translational modifications	PG
pAcUW21	P	VL	No	Polyhedrin gene, F1 origin	PG
pBacPak 8/9 (pair)	P	VL	No	Standard transfer vectors	CT
pBAC-1	P	VL	— <sup>c</sup>	F1 origin	NG
pBacgus-1	P	VL	— <sup>c</sup>	<i>gus</i> reporter gene	NG
pBlue Bac III	P	VL	No	<i>lacZ</i> gene	IN
pAcGHLT-A, B, C (set)	P	VL	Yes	GST and 6×His tags, thrombin cleavage site	PG
pAcHLT-A, B, C (set)	P	VL	Yes	6×His tag, thrombin cleavage site	PG
pBac-2cp	P	VL	Yes	6×His and S tags, F1 origin	NG
pBACgus-2cp	P	VL	Yes	6×His and S tags, F1 origin, <i>gus</i> reporter gene	NG
pBlue Bac His, A, B, C (set)	P	VL	Yes	<i>lacZ</i> gene, 6×His tag	IN
pAc 360	P	VL	Yes	Translational fusion with polyhedrin gene	IN
pAcG1	P	VL	Yes	GST tag	PG
pAcG2T	P	VL	Yes	GST tag, thrombin cleavage site	PG
pAcG3X	P	VL	Yes	GST tag, factor Xa cleavage site	PG
BioColors BV Control (set)	P	VL	Yes	Fusion with GFP or its variants	PG
BioColors His (set)	P	VL	Yes	Fusion with GFP or its variants, 6×His tag, thrombin cleavage site	PG
<i>Secretory-signal vectors</i>					
pAcGP67, A, B, C (set)	P	VL	Yes	gp67 signal sequence for secretion	PG
pAcSecG2T	P	VL	Yes	gp67 signal sequence for secretion, GST tag	PG
pPbac	P	VL	Yes	Placental AKP signal sequence for secretion	SG
pMbac	P	VL	Yes	Melittin signal sequence for secretion	SG
pBac surf-1	P	VL	Yes	gp67 signal sequence for secretion, F1 origin	NG
<i>Ligation-independent cloning vectors</i>					
pAcSG2-LIC	P	VL	No	LIC site for fast PCR cloning	PG
pAcGST-LIC-2T	P	VL	No	GST tag, thrombin cleavage, and LIC sites	PG
pAcGST1-LIC	P	VL	No	GST tag, LIC site	PG

continued

**Table 16.9.1** Baculoviral Expression Vectors<sup>a</sup>, continued

Vector	Promoter	Promoter type	Fusion protein	Features	Source <sup>b</sup>
pBACgus-2cp LIC	P	VL	No	<i>gus</i> reporter gene, 6×His and S tags, thrombin cleavage site, F1 origin, LIC site	NG
pBAC-2cp LIC	P	VL	No	6×His and S tags, thrombin cleavage site, F1 origin, LIC site	NG
<i>Multiple baculovirus promoter vectors</i>					
pAcUW51	P, p10	VL	No	Expression of 2 foreign genes, F1 origin	PG
p2Bac	P, p10	VL	No	Expression of 2 foreign genes	IN
pAcAB3	P, p10	VL	No	Expression of 3 foreign genes	PG
pAcAB4	P, p10	VL	No	Expression of 4 foreign genes	PG
pAcUW31	P, p10	VL	No	Expression of 2 foreign genes, M13 origin	CT
pBAC4x-1	P, p10	VL	— <sup>c</sup>	Expression of 4 foreign genes, F1 origin	NG
pBACgus 4x-1	P, p10	VL	— <sup>c</sup>	Expression of 4 foreign genes, <i>gus</i> reporter gene, F1 origin	NG
<b>p10 locus-based</b>					
<i>Single-baculovirus promoter plasmids</i>					
pAcUW1	p10	VL	No	Standard p10 locus vector	PG
<i>Multiple promoter vector</i>					
pAcUW32/43 (pair)	P, p10	VL	No	Expression of 2 foreign genes, F1 origin	PG
<b>Bacmid expression vectors</b>					
FastBac1	P	VL	No	Bacmid expression system	LT
FastBacHT A,B,C (set)	P	VL	Yes	Bacmid expression system, 6×His tag	LT

<sup>a</sup>Abbreviations: 6×His, six-histidine (tag); BP, basic protein (promoter); CT, Clontech; GFP, green fluorescent protein; GST, glutathione-S-transferase (tag); *gus*, β-glucuronidase; IN, Invitrogen; L, late (promoter); LIC, ligation-independent cloning; LT, Life Technologies; NG, Novagen; P, polyhedrin; PG, Pharmingen; SG, Stratagene; S tag, peptide tag from Novagen; VL, very late (promoter).

<sup>b</sup>See APPENDIX 4 for source addresses and telephone numbers.

<sup>c</sup>Fusion protein optional.

Each secreted protein will present its own characteristics and potential problems for efficient secretion in a biologically active form. In general, the protein produced by baculovirus-infected insect cells carries modifications that are very similar to those of the native protein. With no need for cell lysis, purification of the secreted recombinant proteins is extremely easy. For an example of a recombinant protein expressed and purified in this way, see Murphy et al. (1993). Several vectors have been developed that utilize the gp67 secretory sequence of the baculovirus envelope protein: pAcGP67-A, -B, or -C (Pharmingen) and pBac surf-1 (Novagen). Two additional vectors, pMbac and

pPbac (Stratagene), have insertions, respectively, of the melittin and human placental alkaline phosphatase secretory signal sequences. Additionally, these two vectors contain a p10-promoter-driven *lacZ* gene, allowing color selection of recombinants on Xgal plates.

To improve screening of recombinant baculoviruses when using wild-type AcMNPV DNA, pBlueBacIII (Invitrogen), derived from pJVNheI (Vialard et al., 1990), was developed. pBlueBacIII has a multiple cloning site and contains two promoters—the polyhedrin promoter and the early-to-late (ETL) promoter—downstream with respect to which the *lacZ* gene has been inserted. As with the other bacu-

lovirus vectors, the gene of interest is cloned downstream of the polyhedrin promoter, which then controls synthesis of the recombinant protein. The recombinant virus is plaqued using agarose overlays containing 150  $\mu\text{g}/\text{ml}$  Xgal; the plaques are visualized as described in Basic Protocol 4 of *UNIT 16.10*. Recombinant viruses generate plaques that are blue and lack occlusion bodies.

### CHOOSING A BACULOVIRUS DNA

There are several methods for generating recombinant baculovirus. Initially it was required that researchers cotransfect the recombinant transfer vector with wild-type baculovirus DNA, generate a supernatant containing recombinant baculovirus, and screen out the nonrecombinant wild-type virus background through several rounds of plaque purification. This was a time-consuming process requiring technical expertise developed over a long period of time. The development of modified linearized baculovirus DNA allowed the generation of an initial viral stock containing little or no nonrecombinant virus, thus abolishing the need for plaque purification. The principle of this technique lies in the construction of a modified type of baculovirus DNA which, after linearization, contains a lethal deletion and no longer codes for any viable virus. Cotransfection of the linearized baculoviral DNA with a complementing plasmid construct

rescues the lethal deletion of the essential gene—*ORF 1629*—that lies downstream of the AcMNPV polyhedrin gene of the baculovirus DNA (see Fig. 16.9.3). Therefore, the baculovirus transfer vector must be polyhedrin-locus based to rescue this deficiency. This means that the flanking sequences of its promoter region must be derived from the polyhedrin locus of the AcMNPV wild-type virus, otherwise it will not recombine with the polyhedrin locus of linearized *ORF 1629*-deleted baculoviral DNA. Protocols for both methods are covered in *UNIT 16.10*, which also discusses a new baculovirus variant allowing the gene of interest to be cloned directly into the baculovirus genome, thus obviating the need for transfer vectors.

Another method for avoiding the time-consuming purification by plaque assay is the BAC-TO-BAC system (Life Technologies). The gene of interest is cloned into a donor plasmid, pFastBac 1, and transformed into competent *E. coli* cells containing a helper plasmid and a baculovirus shuttle vector (bacmid). pFastBac 1 contains Tn7 sites, and is transposed into the bacmid using functions supplied by the helper plasmid in *trans*. The recombinant bacmid is isolated from the competent bacteria by miniprep and transfected into insect cells using a cationic lipid reagent (CellFECTIN). Screening for recombinants is done in *E. coli* and can therefore be done much more quickly

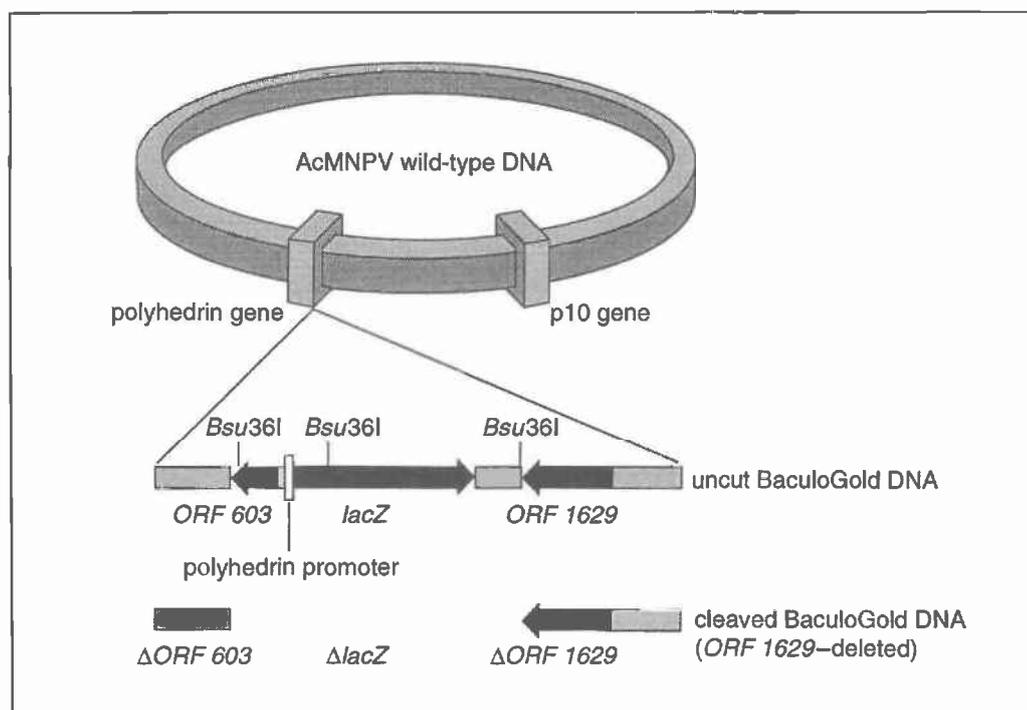

**Figure 16.9.3** Generation and purification of recombinant baculovirus.

than via multiple rounds of plaque purification, as is done in generation of recombinant baculovirus using wild-type virus.

## REAGENTS, SOLUTIONS, AND EQUIPMENT FOR THE BACULOVIRUS SYSTEM

Reagents and solutions commonly used for expression of proteins using baculovirus vectors are summarized below. See *APPENDIX 4* for supplier contact information.

1. *Suitable insect cell lines.* Sf9 cells are derived from the ovaries of the fall armyworm (*Spodoptera frugiperda*) and are available from American Type Culture Collection, Pharmingen, or Invitrogen. A similar cell line, Sf21, is available from the same vendors. As an alternative to *S. frugiperda* cell lines, the *Trichoplusia ni* High Five line, derived from *T. ni* egg-cell homogenates, is available from Invitrogen. Several proteins have been reported to have significantly higher expression using this *T. ni* cell line. Additionally, High Five cells have a rapid doubling time as adherent cultures and adapt quickly to serum-free media.

2. *Fully prepared TNM-FH insect medium.* This will contain trace metals, lactalbumin hydrolysate, yeastolate, 10% fetal bovine serum (FBS), and gentamicin. The medium can be purchased from Pharmingen and several other vendors. It can also be prepared from Grace's insect-cell culture medium (available at 1× and 2× concentration in powdered or liquid form from Life Technologies). For instructions on preparing media from individual components, see O'Reilly et al. (1992). FBS is available from many vendors. Obtain and test different lots of serum from a number of suppliers. The lot that promotes the best growth rate and cell viability should be purchased in bulk. See *APPENDIX 3F* for additional discussion of FBS. Alternatively, a serum-free insect cell culture medium can be purchased from several vendors (BaculoGold medium from Pharmingen, Sf-900 II from Life Technologies, or ExCell 401 from JRH Biosciences). These synthetic, low-protein media are recommended for secreted proteins and facilitate subsequent purification.

3. *Incubator at 27°C ± 1°C.* CO<sub>2</sub> is not required and humidification is optional. The Biological Oxygen Demand (B.O.D.) low-temperature incubator (VWR Scientific) or the larger Isotemp (Fisher) are good examples.

4. *Magnetic spinner flasks.* These are available in a variety of sizes from Techne or Bellco.

5. *Stir plate for multiple spinners.* This is available from Techne or Bellco.

6. *SeaKem ME agarose.* (FMC Bioproducts).

7. *60-mm, 100-mm, and 150-mm tissue culture plates.* (Falcon or Corning).

8. *Antibiotics (optional).* Gentamicin (available from numerous vendors) and amphotericin B (Fungizone from Flow Laboratories) are used.

9. *Microscope.* Either an inverted light microscope or a dissecting microscope is required.

10. *Appropriate cloning vectors.* These are available from many vendors (see Table 16.9.1). Several additional vectors, a manual of methods, and wild-type baculovirus DNA are also available upon request from Dr. Max D. Summers, Department of Entomology, Texas Agricultural Experiment Station, Texas A & M University, College Station, Texas 77843 (Phone: 409-845-9730). It is necessary to sign a licensing agreement before the material will be sent. Commercial kits are available from Pharmingen, Invitrogen, Clontech, Novagen and Stratagene.

11. *Linearized ready-to-use baculovirus DNA.* This can be purchased from many of the same vendors.

## LITERATURE CITED

- Carbonell, L.F., Klowden, M.J., and Miller, L.K. 1985. Baculovirus-mediated expression of bacterial genes in dipteran and mammalian cells. *J. Virol.* 56:153-160.
- Davidson, D.J.C., Fraser, M.J., and Castellino, F.J. 1990. Oligosaccharide processing in the expression of human plasminogen cDNA by lepidopteran insect (*Spodoptera frugiperda*) cells. *Biochemistry* 29:5584-5590.
- Davis, T.R. and Wood, H.A. 1995. Intrinsic glycosylation potentials of insect-cell cultures and insect larvae. *In Vitro Cell. Dev. Biol. Animal* 31:659-663.
- Doerfler, W. and Bohm, P. 1986. *The Molecular Biology of Baculoviruses.* Springer-Verlag, New York.
- Hellers, M., Gunne, H., and Steiner, H. 1991. Expression and post-translational processing of preprocecropin-A using a baculovirus vector. *Eur. J. Biochem.* 199:435-439.
- Grabenhorst, E., Hofer, B., Nimitz, M., Jager, V., and Contradt, H.S. 1993. Biosynthesis and secretion of human interleukin-2 glycoprotein variants from baculovirus-infected insect Sf21 cells: Characterization of polypeptides and post-translational modifications. *Eur. J. Biochem.* 215:189-197.
- James, D.C., Freedman, R.B., Hoare, M., Ogonah, O.W., Rooney, B.C., Larionov, O.A. 1995. N-glycosylation of recombinant human interferon-

γ produced in different animal expression systems. *BioTechnology* 13:592-596.

- Jarvis, D.L. and Finn, E.E. 1995. Biochemical analysis of the N-glycosylation pathway in baculovirus-infected lepidopteran insect cells. *Virology* 212:500-511.
- Jarvis, D.L. and Summers, M.D. 1992. Baculovirus expression vectors. In *Recombinant DNA Vaccines: Rationale and Strategies* (R.E. Isaacson, ed.) pp. 265-291. Marcel Dekker, New York.
- Kitts, P.A. and Possee, R.D. 1993. A method for producing recombinant baculovirus expression vectors at high frequency. *BioTechniques* 14:810-817.
- Livingston, C. and Jones, I. 1989. Baculovirus expression vector with single-strand capability. *Nucl. Acids Res.* 17:2366.
- Luckow, V.A. 1991. Cloning and expression of heterologous genes in insect cells with baculovirus vectors. In *Recombinant DNA Technology and Applications* (A. Prokop, R.K. Bajpai, and C. Ho, eds.) pp. 97-152. McGraw-Hill, New York.
- Luckow, V.A. and Summers, M.D. 1988. Trends in the development of baculoviral expression vectors. *BioTechnology* 6:47-55.
- Matsuura, Y., Possee, R.D., and Bishop, D.H.L. 1987. Baculovirus expression vectors: The requirements for high level expression of proteins, including glycoproteins. *J. Gen. Virol.* 68:1233-1250.
- Miller, L.K. 1988. Baculoviruses as gene expression vectors. *Annu. Rev. Microbiol.* 42:177-199.
- Miller, D.W., Safer, P., and Miller, L.K. 1986. An insect baculovirus host vector for high-level expression of foreign genes. In *Genetic Engineering, Vol. 8* (J.K. Setlow and A. Hollaender, eds.) pp. 277-298. Plenum, New York.
- Murphy, C.I., McIntire, J.R., Davis, D.R., Hodgdon, H., Seals, J.R., and Young, E. 1993. Enhanced expression, secretion, and large-scale purification of recombinant HIV-1 gp120 in insect cells using the baculovirus egt and p67 signal peptides. *Protein Expr. Purif.* 4:349-357.
- Ogonah, O.W., Freedman, R.B., Jenkins, N., Patel, K., and Rooney, B.C. 1996. Isolation and characterization of an insect cell line able to perform complex N-linked glycosylation on recombinant proteins. *BioTechnology* 14:197-202.
- O'Reilly, D.R., Miller, L.K., and Luckow, V.A. 1992. *Baculovirus Expression Vectors*. W.H. Freeman, New York.
- Piwnica-Worms, H., Williams, N.G., Cheng, S.H., and Roberts, T.M. 1990. Regulation of pp60 c-src and its association with polyoma virus middle T antigen in insect cells. *J. Virol* 64:61-68.
- Summers, M.D. and Smith, G.E. 1987. *A manual of methods for baculovirus vectors and insect cell culture procedures*. Texas Agricultural Experiment Station Bulletin No.1555. College Station, Texas.
- Vialard, J., Lalumiere, M., Vernet, T., Briedis, D., Alkhatib, G., Henning, D., Levin, D., and Richardson, C. 1990. Synthesis of the membrane fusion and hemagglutinin proteins of measles virus, using a novel baculovirus vector containing the β-galactosidase gene. *J. Virol* 64:37-50.

#### KEY REFERENCE

O'Reilly et al. See above.

*A guide assembled to aid researchers using the baculoviral expression system, containing detailed protocols for using this system effectively.*

---

Contributed by Cheryl Isaac Murphy  
Aquila Biopharmaceuticals  
Worcester, Massachusetts

Helen Piwnica-Worms  
Washington University School of Medicine  
St. Louis, Missouri

Stefan Grünwald  
Pharming  
San Diego, California

William G. Romanow  
Corning Costar  
Portsmouth, New Hampshire

# Maintenance of Insect Cell Cultures and Generation of Recombinant Baculoviruses

UNIT 16.10

This unit describes the maintenance and care of insect cell cultures as well as the generation, purification, and storage of recombinant baculoviruses. Procedures are included for maintenance and subculturing of insect cells (see Basic Protocol 1) and cotransfection of insect cells with linearized baculovirus DNA and recombinant transfer plasmid containing the gene of interest (see Basic Protocol 2). In the event that the linearized virus is not available, wild-type baculovirus (AcMNPV) DNA may be used to produce recombinant baculoviruses (see Alternate Protocol 1). A procedure is also included for the generation of recombinant baculoviruses using a novel method, direct cloning (see Alternate Protocol 2), which eliminates the need to first clone the gene of interest into a baculoviral transfer vector. Preparation of baculovirus infection stocks from both monolayer and suspension cultures is also described (see Basic Protocol 3). Finally, a protocol is given for a plaque assay to be used for determining the titer of baculoviral stocks as well as for selection of recombinants and plaque purification (see Basic Protocol 4).

**NOTE:** All reagents and equipment coming into contact with live cells must be sterile and proper sterile technique should be used accordingly.

## MAINTENANCE AND CULTURE OF INSECT CELLS

This protocol describes how to maintain and subculture *Spodoptera frugiperda* (Sf9) cells in both monolayer and suspension (spinner) cultures, in either serum-containing or serum-free medium. A culture of insect cells is begun using frozen Sf9 cells. Cultures are maintained by subculturing and their viability is checked periodically. Aliquots of these cultures can be frozen in a liquid nitrogen freezer for long-term storage.

### Materials

TNM-FH insect medium (see recipe) containing 10% fetal bovine serum (FBS), with and without 20% (v/v) DMSO

*Spodoptera frugiperda* (Sf9) cells (ATCC #CRL 1711) derived from fall armyworm ovaries (also see UNIT 16.9)

70% ethanol

0.4% trypan blue stain (Life Technologies)

Serum-free insect cell culture medium (BaculoGold Protein-Free Insect Medium from Pharmingen; Sf-900 II from Life Technologies; or ExCell 401 from JRH Biosciences)

60-mm tissue culture plates or 25-cm<sup>2</sup> flasks

27°C incubator (humidification optional)

Spinner culture flasks (for suspension cultures; Techne or Bellco)

Stir plate for multiple spinner flasks (Techne or Bellco)

Beckman GPR centrifuge with GH-3.7 horizontal rotor (or equivalent)

Screw-top cryostat freezing vials

Liquid nitrogen freezer

Additional reagents and equipment for counting cells with a hemacytometer (APPENDIX 3F)

**BASIC  
PROTOCOL 1**

**Protein  
Expression**

**16.10.1**

Supplement 38

Contributed by Cheryl Isaac Murphy, Helen Piwnica-Worms, Stefan Grünwald, and William G. Romanow

Current Protocols in Molecular Biology (1997) 16.10.1-16.10.17

Copyright © 1997 by John Wiley & Sons, Inc.

BEQ 1016  
Page 250

### ***Begin culture of Sf9 cells***

1. Place 3 ml TNM-FH medium containing 10% FBS in a 60-mm tissue culture plate or 25-cm<sup>2</sup> flask.
2. Thaw a frozen ampule of Sf9 cells rapidly in a 37°C water bath by moving it back and forth by hand. When ampule contents are almost completely thawed, immerse ampule in 70% ethanol to sterilize the outside.
3. Break the neck of the ampule and transfer contents to 60-mm tissue culture plate or 25-cm<sup>2</sup> flask from step 1. Rock plate gently by hand to distribute the cells evenly and incubate 2 to 3 hr at 27°C until cells have attached.
4. Remove old medium and replace with 3 ml fresh TNM-FH/10% FBS. Continue incubation, feeding culture every 3 days (by removing old medium and replacing with fresh) until cells reach confluency (form a packed monolayer).

*It is important to hold the plates at an angle and remove and add medium at one corner so as not to dislodge the cells from the monolayer.*

### ***Maintain and subculture monolayer cultures***

5. Remove the old medium from a confluent plate or flask of Sf9 cells and resuspend cells by gently spritzing them with medium from a pipet.
6. Count the cells using a hemacytometer designed for tissue culture cells (APPENDIX 3F).

*Each cell in a small square of the hemacytometer is equivalent to 10<sup>4</sup> cells/ml.*

7. Seed 1–2 × 10<sup>6</sup> cells from step 5 in new 60-mm plates or 25-cm<sup>2</sup> flasks and rock to evenly distribute the cells (or use a larger plate or flask with more medium if preparing a larger culture of cells). Add fresh TNM-FH/10% FBS to bring the volume to 3 ml.
8. Incubate at 27°C, feeding the culture every 3 days with TNM-FH/10% FBS, until the cells reach confluency.

### ***Maintain and subculture suspension cultures***

9. Remove medium and resuspend cells from confluent monolayer culture as described in step 5. Count the cells using a hemacytometer (APPENDIX 3F).
10. Seed cells in a spinner culture flask at ~4–5 × 10<sup>5</sup> cells/ml. Incubate at 27°C with constant stirring on a stir plate set at 60 to 80 rpm. Leave the side-arm caps slightly loosened to ensure adequate aeration.
11. Count cells every 2 to 3 days using a hemacytometer (APPENDIX 3F). Subculture when cells reach a concentration of 2–2.5 × 10<sup>6</sup> cells/ml by transferring the appropriate number of cells to a new flask containing fresh TNM-FH/10% FBS to achieve a final density of 4–5 × 10<sup>5</sup> cells/ml.

*Alternatively, pour out the appropriate volume of cell suspension and replace it with fresh medium.*

12. Determine cell viability by adding 0.1 ml of 0.4% trypan blue to 1 ml log-phase cells and examining the cells under a microscope at low power. Count the number of cells that take up trypan blue (dead cells) and count the total number of cells, then calculate the percentages of dead cells and viable cells.

*A healthy culture of cells should be >97% viable. To maintain a sufficient transfer of oxygen to the cells in suspension, a minimum ratio of surface area to volume of culture must be maintained (Maiorella et al., 1988). If this value decreases, the cells will not grow exponentially and will stop growing at a lower cell density. This ratio is adequate for a 100-ml culture grown in a 100-ml spinner flask, but decreases when larger spinner flasks*

are used at maximum volume. Thus, to maintain sufficient oxygen transfer, smaller volumes should be used in the larger flasks unless an outside source of air is introduced into the flask (UNIT 16.11).

#### **Adapt cells to serum-free medium**

13. Subculture monolayer cells (from step 5) or suspension cells (from step 11) into medium composed of one part complete TNM-FH/10% FBS and one part serum-free medium (BaculoGold, Sf-900 II, or ExCell 401). Allow cells to grow to confluency (monolayer cultures) or to a density of  $2-3 \times 10^6$  cells/ml (suspension cultures).

*Other commercially available serum- or protein-free media besides BaculoGold. Sf-900 II, and ExCell 401 may be used. The final choice of serum-free medium should be based on a comparison of cell growth curves and production of recombinant protein in different media.*

14. Repeat the subculture and growth procedure as in step 13 using a medium composed of one part FBS-containing complete medium and three parts serum-free medium.
15. Repeat the subculture and growth procedure as in step 13 using a medium composed of one part FBS-containing complete medium and between 7 and 9 parts serum-free medium.
16. Subculture the cells into serum-free medium.

*Cells may adapt slowly to serum-free medium and may require several passages before growth rates and viability return to normal.*

#### **Freeze cells**

17. Count cells to be frozen from an exponentially growing culture using a hemacytometer (APPENDIX 3F).
18. Centrifuge cells 10 min at  $1000 \times g$  (2000 rpm in a GH-3.7 rotor), room temperature, and discard supernatant.
19. Resuspend cell pellet at  $1-2 \times 10^7$  cells/ml in TNM-FH/10% FBS. Add an equal volume of TNM-FH/10% FBS containing 20% DMSO and place cells on ice. Dispense 1-ml aliquots of this cell suspension into screw-top cryostat freezing vials and incubate 1 hr at  $-20^\circ\text{C}$ , then overnight at  $-70^\circ\text{C}$ .

*Alternatively, cells can be frozen using serum-free medium (with and without DMSO) if the cells have been adapted to serum-free medium as described in steps 13 to 16.*

20. Transfer frozen cells to a liquid nitrogen freezer for long-term storage.

### **COTRANSFECTION OF INSECT CELLS USING LINEARIZED BACULOVIRAL DNA**

One of the most commonly used methods of introducing baculovirus and transfer-plasmid DNA into susceptible insect cells is to coprecipitate the DNA with calcium phosphate and present the mixture to insect cells. For cotransfection, prepare  $\geq 10 \mu\text{g}$  of purified plasmid DNA. Care must be taken that the plasmid is as clean as possible. With impure plasmids, cells may lyse shortly after transfection, resulting in a lower viral titer. At  $\sim 24$  hr post-transfection, Sf9 cell viability should be greater than 97%.

It should be noted that this protocol is optimized for use with Pharmingen linear DNA. Clontech and Invitrogen (see APPENDIX 4) have their own protocols for use with the linear DNA that they offer.

**BASIC  
PROTOCOL 2**

**Protein  
Expression**

**16.10.3**

## Materials

*Spodoptera frugiperda* (Sf9) cells growing in tissue culture at 50% to 70% confluence or growing in suspension culture at  $1\text{--}1.5 \times 10^6$  cells/ml (see Basic Protocol 1)

TNM-FH insect medium (see recipe) containing 10% fetal bovine serum (FBS)

Linearized ORF 1629–deleted AcMNPV DNA (e.g., BaculoGold from Pharmingen; see Fig. 16.9.3)

Recombinant baculovirus transfer vector containing gene of interest (UNIT 16.9)

Transfection buffer B (see recipe)

Control transfer vector: pVL1392-Xyle (Pharmingen)

Transfection buffer A (see recipe)

500 mM catechol/50 mM sodium bisulfate

60-mm tissue culture plates

27°C incubator (humidification optional)

Inverted microscope

15-ml conical centrifuge tubes

Beckman GPR centrifuge with GH-3.7 horizontal rotor (or equivalent), 4°C

Additional reagents and equipment for amplification of viral supernatants to produce baculoviral stocks (see Basic Protocol 3) and plaque assay of baculovirus (see Basic Protocol 4)

## Prepare cells and DNA

1. In each of three 60-mm tissue culture plates seed  $2 \times 10^6$  Sf9 cells in TNM-FH medium containing 10% FBS. Incubate in a 27°C incubator until cells attach.

*Cell attachment should be done on a flat and even surface, allowing the cells to attach firmly, which usually takes ~5 min. If cells do not attach after that time, either they are not healthy or the wrong plates (e.g., petri dishes that have not been tissue culture treated) have been used.*

*The quality of the insect cells is very important and only rapidly dividing cells should be used.*

2. While cells are attaching, combine in a microcentrifuge tube 0.5 µg linearized ORF 1629–deleted AcMNPV DNA and 2 to 5 µg recombinant baculovirus transfer vector containing the gene of interest. Mix well by gently vortexing or flicking the tube. Let mixture sit 5 min, then add 1 ml transfection buffer B.
3. Prepare positive control by combining, in a microcentrifuge tube, 0.5 µg linearized ORF 1629–deleted AcMNPV DNA and 2 µg pVL1392-Xyle control transfer vector DNA. Mix well by gently vortexing or flicking the tube. Let mixture sit 5 min, then add 1 ml transfection buffer B.
4. Label the first plate (from step 1) as the cotransfection plate. Aspirate old medium and replace with 1 ml transfection buffer A, making sure that the entire surface of the plate is covered to prevent the cells from drying out.
5. Label the second plate (from step 1) as the positive control. Aspirate old medium and replace with 1 ml of transfection buffer A, as in step 4.
6. Label the third plate (from step 1) as negative control. Aspirate old medium and replace with 3 ml fresh TNM-FH/10% FBS, without adding any DNA.

of 0.1. Incubate 3 to 5 days at 27°C, examining plates periodically with an inverted microscope for the presence of occlusion bodies.

*Dr. Max D. Summers provides a manual with his materials that includes details for these procedures. Pharmingen provides similar documentation with its wild-type baculovirus. Also see O'Reilly et al. (1992).*

*MOI is equal to plaque-forming units (pfu; see Basic Protocol 4) divided by the number of cells (pfu/cell). If the supplier of the virus does not provide adequate information regarding pfu, this can be determined by plaque assay (see Basic Protocol 4).*

*Occlusion bodies are highly refractile, giving them a yellowish-green crystalline appearance that is readily detected under a light microscope.*

2. When occlusion bodies are observed in most cells, pool the viral supernatant (~30 ml per plate) in six 50-ml conical tubes. Centrifuge 10 min at  $1000 \times g$  (2000 rpm in GH-3.7), 4°C, then pour viral supernatant into six new tubes. Repeat centrifugation to completely remove any remaining cells.

*Sterile technique is not required in this step nor for any of the remaining steps of this protocol.*

3. Place 6 to 35 ml of viral supernatant in each of an appropriate number of ultracentrifuge tubes for the SW-27 or SW-28 rotor and balance the tubes. Underlay with 3 ml sucrose cushion solution. Precool the ultracentrifuge and rotor to 4°C.

*The amount of sucrose cushion may have to be increased for larger volumes of viral supernatant.*

4. Centrifuge 60 min at  $100,000 \times g$  (24,000 rpm in an SW-27 or -28 rotor), 4°C, to pellet the virus. Pour off supernatants and invert tubes on a Kimwipe to drain as much liquid as possible.

#### ***Separate virus from cellular contaminants (if necessary)***

5. Examine the viral pellets carefully. If the viral pellet is pure (i.e., has a light bluish appearance), proceed to DNA isolation (step 11). If the pellet appears yellowish, separate the virus from cellular contaminants by steps 6a to 10a or 6b to 10b.

#### ***To purify viral pellet by sucrose-gradient fractionation***

- 6a. Add 2 ml of  $0.1 \times$  TE buffer to one of the viral pellets and repeatedly pipet up and down with a Pasteur pipet to resuspend. Transfer the buffer with the resuspended virus to a second tube containing a pellet and repeat the resuspension, then repeat in turn for each pellet until all pellets are pooled in the same 2 ml.

*If pellet is difficult to resuspend, incubate preparation overnight at 4°C.*

- 7a. Place 25% and 56% sucrose solutions in  $0.1 \times$  TE buffer in the reservoirs of a gradient maker and prepare two linear 25% to 56% sucrose gradients in SW-41 ultracentrifuge tubes.

*If a gradient maker is unavailable, simply layer the 25% sucrose carefully atop the 56% sucrose to form a step gradient. Some investigators report that a step gradient gives a sharper band.*

- 8a. Carefully layer 1 ml of the pooled viral suspension on top of each sucrose gradient. Centrifuge 90 min at  $100,000 \times g$  (28,000 rpm in an SW-41 rotor), 4°C.

*After centrifugation, virus should be visible as a broad bluish-white band inside the gradient.*

- 9a. Using a Pasteur pipet, transfer the viral bands to a new SW-41 ultracentrifuge tube. Add enough 0.1× TE buffer to fill the tube (~35 ml), then centrifuge 30 min at  $100,000 \times g$  (28,000 rpm in an SW-41 rotor), 4°C, to pellet the virus. Decant supernatant and invert tube on a Kimwipe to drain as much liquid as possible.
- 10a. Resuspend the virus pellet in 9 ml extraction buffer and transfer 4.5-ml aliquots to two 15-ml polypropylene centrifuge tubes. Proceed to step 11.

*To purify viral pellet by microcentrifugation*

- 6b. Add 3 ml extraction buffer to one of the viral pellets and repeatedly pipet up and down with a Pasteur pipet to resuspend. Transfer the buffer with the resuspended virus to a second tube containing a pellet and repeat the suspension, then repeat in turn for each pellet until all pellets are pooled in the same 3 ml.

*If pellet is difficult to resuspend, incubate preparation overnight at 4°C.*

- 7b. Transfer 1.5 ml viral suspension into each of two 1.5-ml microcentrifuge tubes. Microcentrifuge 5 min at maximum speed and pool supernatants in one 15-ml polypropylene centrifuge tube.
- 8b. Resuspend each pellet in 1 ml extraction buffer.
- 9b. Microcentrifuge the pellets 5 min at maximum speed and combine the two supernatants with the pooled supernatants in the 15-ml tube.
- 10b. Bring volume in the 15-ml tube to 9 ml with extraction buffer and transfer 4.5-ml aliquots to two new 15-ml polypropylene centrifuge tubes. Proceed to step 11.

*Isolate DNA from purified virions*

11. Add 200 µl of 10 mg/ml proteinase K to each tube and incubate 1 to 2 hr at 50°C.
12. Add 0.5 ml of 10% N-lauroylsarcosine to each tube and incubate 2 hr or overnight at 50°C.
13. Extract DNA twice with an equal volume of 25:24:1 phenol/chloroform/isoamyl alcohol (see *UNIT 2.1* for additional details on extraction of DNA).

*Extreme care should be taken to be as gentle as possible to avoid shearing the DNA at this point. Use a wide-bore Pasteur pipet and mix DNA solutions by inverting the tubes rather than by vortexing.*

14. Transfer the aqueous phase containing the DNA to another 15-ml tube using a wide-mouth 5- to 10-ml pipet. Add 10 ml of ice-cold 100% ethanol to each tube and mix gently by inverting the tubes several times. Incubate 10 min at -80°C (see *UNIT 2.1* for additional details on ethanol precipitation of DNA).
15. Centrifuge 20 min at  $1500 \times g$  (2500 rpm in GH-3.7 rotor), 4°C, and discard supernatant. Rinse the DNA pellet with 70% ethanol and air dry pellet for 30 to 60 min. Resuspend pellet in 800 µl of 1× TE buffer.
16. Transfer 400 µl of the resuspended DNA to each of two microcentrifuge tubes and reprecipitate the DNA by adding 40 µl of 3 M sodium acetate and 2 vol of ice-cold 100% ethanol to each tube. Incubate 10 min at -80°C.
17. Microcentrifuge 10 min and discard supernatant. Rinse DNA pellet with 70% ethanol and air dry pellet. Resuspend DNA in 0.3 to 1.0 ml of 1× TE buffer.
18. Quantitate DNA by measuring  $A_{260}$  (*APPENDIX 3D*) and calculate yield. Store the circular wild-type baculoviral DNA at 4°C (stable for several months).

*This method should yield 50 to 100 µg viral DNA per ten 150-mm dishes. If difficulty is encountered resuspending the DNA, heat mixture for ~15 min at 65°C.*

### **Transfect cells**

7. Add 1 ml of the solution prepared in step 2 (containing the vector with the gene of interest) drop-by-drop to the cotransfection plate. After every three to five drops, gently rock the plate back and forth to mix the drops with the medium.

*During this procedure, a fine calcium phosphate/DNA precipitate should form. The quality of the precipitate that is optimal for transfection can be assessed visually. It should be of a fine white milky appearance.*

8. Add 1 ml of the solution prepared in step 3 (containing the positive control vector) drop-by-drop to the positive control plate, repeating the procedure in step 7.
9. Incubate all three plates 4 hr in a 27°C incubator.

*The time of exposure to the calcium precipitate is critical for optimal transfection results. If the incubation time is too long, cell viability will be dramatically reduced. For different cell lines, the optimal incubation time varies. For Sf9 cells, the optimal time is 4 hr.*

10. After 4 hr, remove the medium from the cotransfection plate and the positive control plate (but not the negative control plate). Add 3 ml fresh TNM-FH/10% FBS to each plate, rock the plate back and forth several times, then remove all the medium again. Add 3 ml of fresh TNM-FH/10% FBS to each plate and incubate all three plates 4 to 5 days at 27°C.

*It is not necessary to change the medium of the negative control plate.*

### **Check for successful transfection**

11. After 4 days, check the three plates for signs of infection using an inverted microscope. Compare the negative and positive controls to the cotransfection plate.

*Infected cells are much larger than uninfected cells and have enlarged nuclei. Because they stop dividing early in infection, their cell density will be much lower as compared to the uninfected population. Furthermore, infected cells do not attach well to the plate and a high percentage of them will float in the medium. Many of these infection signs may not be visible at this time because the virus titer during the cotransfection is usually low. A further amplification step (see below) may be needed to visualize these changes.*

12. After 5 days, collect the supernatants of the cotransfection and positive control plates. Determine viral titer by plaque screening (see Basic Protocol 4).

*Alternatively, cotransfection efficiency may be assessed by endpoint dilution assay (see Basic Protocol 4, step 7 annotation).*

13. Check the expression of the protein of interest by lysing the transfected cells (for recombinant proteins that are not secreted) or using an aliquot of the supernatant (for recombinant proteins that are secreted), and performing an appropriate assay.

*Unless a sensitive assay is available for the protein of interest, expression of the recombinant protein may not be detectable at this stage.*

14. Assay for cells expressing the XylE protein in the positive control plate by adding 100 µl of 500 mM catechol/50 mM sodium bisulfate.

*Infected cells expressing XylE protein will turn bright yellow in ~5 min.*

15. Transfer the transfection supernatants from each plate to sterile conical 15-ml centrifuge tubes and centrifuge 10 min at 1000 × g (2000 rpm in GH-3.7 rotor), 4°C. Transfer viral supernatant to new sterile tubes and store at 4°C in the dark.

16. Amplify viral supernatant to produce a high-titer virus stock for production of the recombinant protein by infection of insect cells (see Basic Protocol 3).

*Alternatively, a single recombinant virus, obtained by plaque purification (see Basic Protocol 4), may be used for virus amplification.*

## GENERATION OF RECOMBINANT BACULOVIRUS USING WILD-TYPE BACULOVIRAL DNA

As an alternative to linearized ORF 1629–deleted baculoviral DNA, circular wild-type AcMNPV DNA can be used for cotransfection of insect cells with baculoviral transfer plasmids (also see Basic Protocol 2). However, recombination efficiency is dramatically lower (usually around 0.1% to 0.2%) as compared to that obtained with linearized DNA. The technique described here thus requires the identification and purification of recombinants by multiple rounds of plaque assay.

The following protocol describes how to isolate and purify AcMNPV wild-type baculoviral DNA, which can then be used to cotransfect susceptible insect cells (e.g., *Sf9*) with an appropriate plasmid vector to generate recombinant baculoviruses. The cotransfection of wild-type baculovirus DNA and recombinant transfer plasmid should be performed as described in Basic Protocol 2 (using wild-type baculoviral DNA instead of linearized ORF 1629–negative AcMNPV DNA). To facilitate screening between wild-type and recombinant viral plaques, pBlueBacIII (Invitrogen) or pVL1393-Xyle (Pharmingen) can be used as a positive control, making it possible to visualize differences between nonrecombinant wild-type viral plaques and recombinant viral plaques.

Wild-type baculovirus available upon request from Dr. Max D. Summers, Department of Entomology, Texas Agricultural Experiment Station, Texas A & M University, College Station, Texas 77843 (Phone: 409-845-9730).

### *Additional Materials (also see Basic Protocol 2)*

- Wild-type baculovirus (Dr. Max D. Summers, see above, or Pharmingen)
- Sucrose cushion solution (see recipe)
- 0.1× and 1× TE buffer, pH 7.4 (APPENDIX 2)
- 25% and 56% (w/v) sucrose (ultrapure) in 0.1× TE buffer (filter sterilize and store up to 1 month at 4°C)
- Extraction buffer (see recipe)
- 10 mg/ml proteinase K (prepare fresh)
- 10% *N*-lauroylsarcosine (sodium salt; filter sterilize and store up to 1 year at 4°C)
- 25:24:1 phenol/chloroform/isoamyl alcohol (UNIT 2.1)
- 100% (ice-cold) and 70% (room temperature) ethanol
- 3 M sodium acetate, pH 5.2 (APPENDIX 2)
- 150-mm tissue culture dishes
- 50-ml conical centrifuge tubes
- Beckman GPR centrifuge with GH-3.7 horizontal rotor (or equivalent), 4°C
- Beckman ultracentrifuge with SW-27 or SW-28 rotor and SW-41 rotor (or other ultracentrifuge with equivalent rotors), 4°C, and appropriate tubes
- Sucrose gradient maker
- 15-ml polypropylene centrifuge tubes
- 50°C water bath
- 5- or 10-ml wide-mouth pipets
- Additional reagents and equipment for phenol/chloroform extraction and ethanol precipitation of DNA (UNIT 2.1) and quantitating DNA by absorbance spectrometry (APPENDIX 3D)

### *Prepare viral supernatant and collect virus*

1. Seed at least ten 150-mm plates with  $2.0 \times 10^7$  *Sf9* cells/plate in 30 ml TNM-FH medium containing 10% FBS. Incubate 1 hr at 27°C to allow the cells to attach firmly, then infect them with AcMNPV wild-type virus at a multiplicity of infection (MOI)

19. Cotransfect *Sf9* cells with the circular wild-type baculoviral DNA and a baculoviral transfer plasmid containing a gene of interest as in Basic Protocol 2, substituting the wild-type DNA for the linearized ORF 1629–deleted DNA in step 2 of that protocol.

*Recombination efficiency is dramatically lower with wild-type DNA as compared to that obtained with linearized DNA. The technique described here thus requires the identification and purification of recombinants by multiple rounds of plaque assay (see Basic Protocol 4).*

### GENERATION OF RECOMBINANT BACULOVIRUSES BY DIRECT CLONING

This protocol describes the generation of recombinant virus by direct cloning methods (see Fig. 16.10.1), which may be applicable to the production of high-diversity expression libraries in baculovirus. Two modified AcMNPV baculoviruses—vEHuni and vECuni—have been constructed that have two *Bsu36I* sites downstream, respectively, of the *hsp70* promoter and the synthetic promoter *PcapminXIV* (Lu and Miller, 1996). Cleavage of the *Bsu36I* sites produces overhanging TTA ends, which are filled in by incubation with the Klenow fragment of DNA polymerase I in presence of dTTP, thus leaving a TT overhang. Ready-to-use vEHuni and vECuni baculoviral DNA can be purchased from Pharmingen. The gene to be cloned must be flanked by *EcoRI* sites and the *EcoRI* ends produced by cleavage at these sites have to be partially filled in with Klenow fragment in the presence of dATP to leave AA overhangs. The gene can then be cloned directly into the vEHuni or vECuni genome.

### ALTERNATE PROTOCOL 2

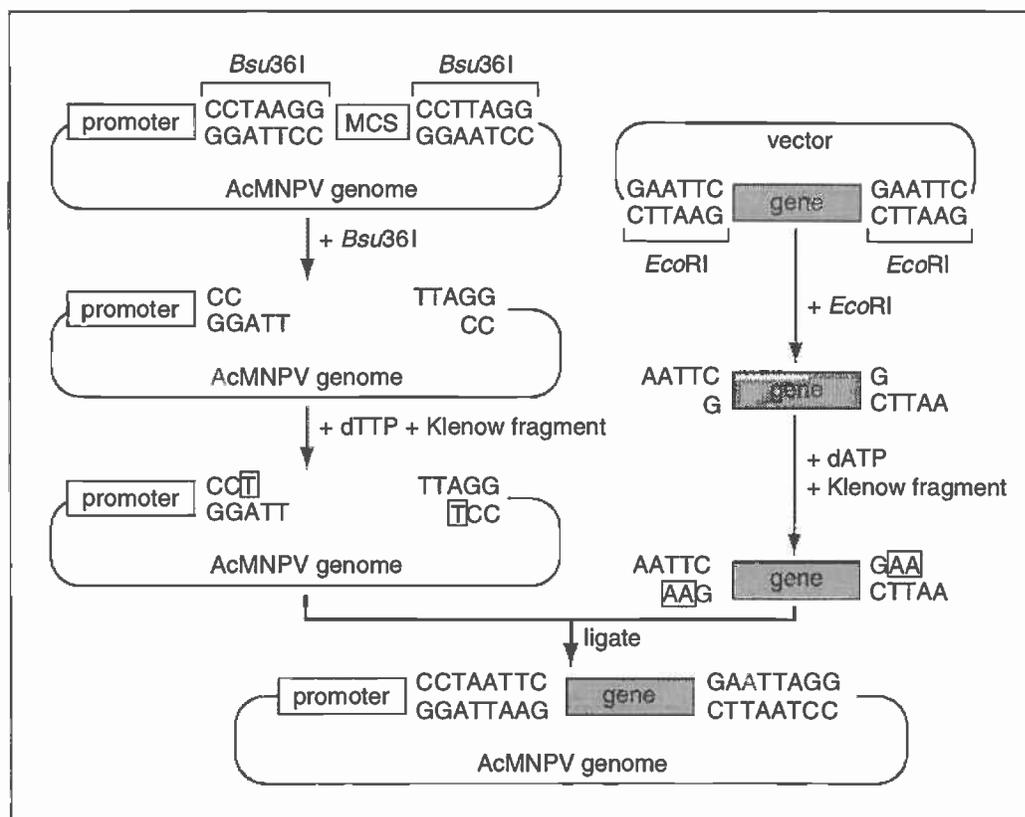

**Figure 16.10.1** Direct cloning of a gene of interest into baculovirus DNA. At the left is a diagram representing an AcMNPV recombinant containing two different *Bsu36I* sites. Digestion of this viral DNA with *Bsu36I* followed by a partial fill-in reaction with dTTP and Klenow fragment of DNA polymerase I generates a linear viral DNA with TT overhanging ends. At the right, a foreign gene with flanking *EcoRI* sites is digested with *EcoRI* to generate overhanging ends, which are then partially filled in using dATP. The resulting AA overhanging ends are then compatible with the TT overhanging ends of the viral DNA. The viral DNA and foreign gene DNAs are then combined, ligated, and transfected into insect cells.

### Protein Expression

### 16.10.9

*Additional Materials (also see Basic Protocol 2)*

Purified vector containing gene of interest, flanked by *EcoRI* sites  
Klenow fragment of DNA polymerase I (UNIT 3.5)  
Reaction buffer for Klenow fragment (see recipe)  
25:24:1 phenol/chloroform/isoamyl alcohol (UNIT 2.1)  
1× TE buffer (APPENDIX 2)  
vEHuni or vECuni (Pharming), linearized, partially filled in by Klenow  
fragment treatment, and containing TTA ends  
T4 DNA ligase (UNIT 3.14)  
15°C water bath

Additional reagents and equipment for agarose gel electrophoresis (UNIT 2.5A) and  
phenol/chloroform extraction and ethanol precipitation of DNA (UNIT 2.1)

1. Digest vector containing gene of interest with *EcoRI* in a total volume of 50 µl for 16 hr at 37°C and isolate gene of interest that contains flanking *EcoRI* sites by agarose gel electrophoresis (UNIT 2.5A).

*If gene of interest does not contain flanking EcoRI sites, a polymerase chain reaction with specific primers containing EcoRI sites can be used to insert flanking EcoRI sites. Alternatively, EcoRI linkers can be ligated to the purified gene.*

2. In a total volume of 50 µl, incubate up to 5 µg of *EcoRI*-digested and purified gene of interest with 5 U Klenow fragment in reaction buffer for Klenow fragment for 20 min at 37°C.
3. Extract reaction mix with 1 vol of 25:24:1 phenol/chloroform/isoamyl alcohol, then ethanol precipitate DNA and resuspend in 10 µl of 1× TE buffer (UNIT 2.1).
4. In a total volume of 50 µl, mix 0.5 µg vEHuni or vECuni DNA with 0.1 to 1 µg of the treated gene fragment from step 3 (to obtain an ~1:60 molar ratio of baculoviral DNA to gene fragment), and add 2 U T4 DNA ligase. Incubate overnight at 15°C.

*The ligated AcNPV DNA is now ready to be transfected into susceptible insect cells.*

5. Transfect the entire ligation mixture from step 4 into  $2 \times 10^6$  *Sf9* cells as described in Basic Protocol 2.

*The ligation mixture from this protocol replaces the reaction mixture composed of ORF 1629-deleted AcMNPV DNA and recombinant baculovirus transfer vector used in step 2 of Basic Protocol 2. As in Basic Protocol 2, use pVLI392-Xyle as a control.*

*To purify recombinant plaques obtained by direct cloning, see Basic Protocol 4.*

**BASIC  
PROTOCOL 3**

**PREPARATION OF BACULOVIRUS STOCKS**

This protocol describes how to prepare a large-scale stock of wild-type or recombinant AcMNPV virus from either monolayer or suspension culture. Growing insect cells (*Sf9*) are infected with virus at a low MOI (<1.0). A viral stock is obtained by harvesting the culture supernatant when the majority of cells show cytopathic effects (~4 to 5 days postinfection). Viral stocks can be stored at 4°C, but must be shielded from light to maintain the viral titer. Liquid nitrogen freezing is recommended for long-term storage. Plaque assay should be used to determine the titer of viral stocks.

**Materials**

*Sf9* cells in monolayer culture (see Basic Protocol 1, step 5) or suspension culture  
(see Basic Protocol 1, step 11)  
TNM-FH insect medium (see recipe) containing 10% fetal bovine serum (FBS)

Maintenance of  
Insect Cell  
Cultures and  
Generation of  
Recombinant  
Baculoviruses

16.10.10

Baculoviral inoculum, wild-type (UNIT 16.9) or recombinant (e.g., supernatant from cotransfected *Sf9* cells; see Basic Protocol 2), pfu determined by plaque assay (see Basic Protocol 4)

150-mm tissue culture dishes

27°C incubator (humidification optional)

Inverted microscope

Beckman GPR centrifuge with GH-3.7 horizontal rotor (or equivalent), 4°C

Screw-top cryostat freezing vials

Liquid nitrogen freezer

500-ml spinner culture flasks (Techne or Bellco)

Stir plate for multiple spinner flasks (Techne or Bellco)

#### *To amplify virus from monolayer cultures*

- 1a. Seed two 150-mm plates with  $1.8 \times 10^7$  *Sf9* cells/dish maintained in TNM-FH medium containing 10% FBS. Incubate 1 hr in a 27°C incubator to allow cells to attach.
- 2a. While cells are attaching, add the viral inoculum to 30 ml of fresh TNM-FH/10% FBS in sufficient quantity to achieve an MOI of 0.1 to 1. When cells have attached, remove the medium from the plates and add 15 ml of this virus-containing medium to each plate.

*MOI is defined as pfu/cell. The volume of viral inoculum needed to infect a given number of cells equals  $MOI \times (\text{number of cells/titer of viral stock in pfu/ml})$ .*

- 3a. Incubate cells with virus-containing medium for several days at 27°C. Examine the cells daily under an inverted microscope for signs of infection—i.e., cytopathic effects (if occlusion body–negative recombinant viruses are used) or occlusion bodies (if wild-type baculovirus or occlusion body–positive recombinant viruses are used).

*Occlusion bodies are highly refractile, giving them a yellowish-green crystalline appearance that is readily detected under a light microscope.*

- 4a. When the majority of cells show cytopathic effects or occlusion bodies (usually 4 to 5 days postinfection) transfer the cells to sterile tubes, centrifuge 10 min at  $1000 \times g$  (2000 rpm in a GH-3.7 rotor), 4°C, and transfer supernatant to new, sterile tubes. Dispense several 1-ml aliquots into screw-top cryostat freezing vials and freeze them in a liquid nitrogen freezer for long-term storage. Keep the remaining stock at 4°C in the dark for short-term storage.

*This protocol should result in ~40 ml of a virus stock at  $1 \times 10^8$  to  $3 \times 10^8$  pfu/ml.*

*If the virus to be amplified is a single plaque isolate (see Basic Protocol 4), place the agarose plug in a microcentrifuge tube containing 0.5 ml TNM-FH/10%FBS and rotate the tube overnight at 4°C. Infect fresh *Sf9* cells as in step 1a using  $2 \times 10^6$  cells in a 100-mm flask and incubate 1 hr at 27°C. Add 8 ml of TNM-FH/10% FBS medium and incubate them for 4 days at 27°C. Harvest the virus as in step 4a. Determine the viral titer by plaque assay (see Basic Protocol 4) and amplify the virus by repeating steps 1a to 3a to obtain a high-titer stock. Virus stocks can also be prepared in serum-free insect cell culture medium if the cells have been adapted to serum-free medium (see Basic Protocol 1). Follow steps 1a to 4a but use serum-free culture medium instead of TNM-FH/10% FBS medium.*

#### *To amplify virus from suspension cultures*

- 1b. Grow *Sf9* cells in a 500-ml spinner culture bottle with 50 ml TNM-FH/10% FBS to a density of  $\sim 1 \times 10^6$  cells/ml (see Basic Protocol 1).

**Sf21* cells (see UNIT 16.9) may be used instead of *Sf9* cells. They are grown in the same way as *Sf9* cells.*

- 2b. Centrifuge cells 10 min at  $1000 \times g$ , room temperature, and discard supernatant. Resuspend cell pellet in 10 to 20 ml fresh TNM-FH/10% FBS. Add viral inoculum at an MOI of 0.1 to 0.5.

*See annotation to step 2a regarding how to calculate the volume of viral inoculum needed.*

- 3b. Add cells back to spinner flask and bring volume to 100 ml with TNM-FH/10% FBS. Incubate 3 to 4 days at  $27^{\circ}\text{C}$  with constant stirring on a stir plate set at 60 to 80 rpm. Leave the side-arm caps slightly loosened to ensure adequate aeration. Periodically remove aliquots of the suspension and examine microscopically for cytopathic effects and occlusion bodies.
- 4b. When the majority of cells show cytopathic effects or occlusion bodies (usually 4 to 5 days postinfection) transfer the cells to sterile tubes, centrifuge 10 min at  $1000 \times g$ ,  $4^{\circ}\text{C}$ , and transfer supernatant to new sterile tubes. Dispense several 1-ml aliquots into screw-top cryostat freezing vials and freeze them in a liquid nitrogen freezer for long-term storage. Keep the remaining stock at  $4^{\circ}\text{C}$  in the dark for short-term storage.

*Virus stocks can also be prepared in suspension by growing insect cells (Sf9, Sf21, and High Five) in serum-free or protein-free insect cell culture medium in either a 100-ml spinner flask or a 500-ml spinner flask filled only to 250 ml until the cell density is  $1-2 \times 10^6$  cells/ml. Virus should be added at an MOI of 0.1 to 0.5 directly to the suspension culture, the cells incubated 4 to 5 days, and the virus harvested as in step 4b.*

## BASIC PROTOCOL 4

### TITERING BACULOVIRUS STOCKS USING PLAQUE ASSAY

This protocol describes how to titer viral stocks using the plaque-assay procedure. When preparing new viral stocks or when carrying out infections for protein production and protein analyses, it is important to know the titer of a viral stock, which is expressed in plaque-forming units per milliliter (pfu/ml). In this procedure, serial dilutions of viral stock are used to infect exponentially growing Sf9 cells. After removing the viral supernatant, the cells are covered with an agarose overlay and incubated 6 to 10 days. Plaques are counted visually to determine the viral titer. To become familiar with the morphological differences between plaques produced by wild-type virus versus those produced by recombinant virus, it is helpful to first practice plaquing  $\beta$ -Gal recombinant virus alongside wild-type virus (in a manner analogous to that used with plaque purification of bacteriophage; UNIT 1.11). This greatly facilitates screening of recombinant viruses encoding the gene of interest. It is possible to distinguish a wild-type plaque from a recombinant plaque by holding the plate overhead and looking at the bottom of the plate directly. Regions surrounding wild-type plaques will look grayish-white, whereas recombinant plaques will not. After identifying putative recombinant viral plaques by one of these methods, pick several plaques and place the agarose plugs in 1-ml serum-free medium. Vortex and store up to several months at  $4^{\circ}\text{C}$  until needed.

#### Materials

Exponentially growing Sf9 cells (see Basic Protocol 1) in monolayer culture  
TNM-FH insect cell medium (see recipe) with and without 10% fetal bovine serum (FBS)

Baculoviral stock

Agarose overlay (prepare 30 min before use in step 5; see recipe)

Trypan blue overlay (optional; see recipe)

60-mm tissue culture plates

$27^{\circ}\text{C}$  incubator (humidification optional)

1.5-ml screw-top cryostat tube

1. Dilute a culture of exponentially growing Sf9 cells to  $\sim 5 \times 10^5$  cells/ml in TNM-FH medium containing 10% FBS. Seed cells onto 60-mm tissue culture plates at two different densities— $2 \times 10^6$  and  $1.5 \times 10^6$  cells/plate—several hours before plating. Set up duplicate plates for each dilution of viral stock. Incubate in 27°C incubator.

*Duplicates of each dilution are required because of the variability encountered using plaque assays. Thus, there will be four plates for each dilution: two with  $2 \times 10^6$  cells and two with  $1.5 \times 10^6$  cells. Generally, a total of three viral dilutions are plated, necessitating a total of twelve dishes for each stock being titered (six with  $2 \times 10^6$  cells and six with  $1.5 \times 10^6$  cells).*

*The density of the cell monolayer is critical to the success of the plaque assay. If the plaques are too small after 5 days, the initial cell density was too high. If the plaques are large and diffuse, the initial cell density was too low. Use a series of cell densities to find the optimal plating cell density for the particular cell line being used.*

2. When ready to plate, make 5-ml serial dilutions of the baculoviral stocks in TNM-FH medium/10% FBS as follows, depending on the nature of the viral stock:

high-titer viral stock— $10^{-6}$ ,  $10^{-7}$ , and  $10^{-8}$  dilutions

transfection supernatant from circular AcMNPV DNA— $10^{-4}$ ,  $10^{-5}$ , and  $10^{-6}$  dilutions

transfection supernatant from linear AcMNPV DNA— $10^{-1}$  and  $10^{-2}$  dilutions

single plaque pick-ups— $10^{-1}$ ,  $10^{-2}$ , and  $10^{-3}$  dilutions.

*Making serial dilutions is analogous to titering phage stocks (see UNIT 1.11).*

3. Remove medium from cells (from step 1) with a sterile pipet. Add 1 ml of each viral dilution to duplicate plates and incubate 1 hr at 27°C. Rock the plates when adding the virus inoculum to ensure even infection of the cells.

*It is important to hold the plates at an angle and remove and add medium at one corner so not to dislodge the cells from the monolayer.*

4. After 1 hr incubation, prepare the agarose overlay.

*The agarose overlay keeps the virus released from the infected cells from diffusing far from the site where the initial infection took place. Thus, only cells immediately neighboring the cell of primary infection are subsequently infected by progeny virus. When enough cells in the immediate vicinity of the primary infection are lysed, a plaque (or hole in the cell monolayer) results.*

5. Remove the viral supernatant from the cells with a sterile pipet and add 4 ml agarose overlay. Allow the agarose to harden on the plates for 10 to 20 min at room temperature (to allow condensation to escape). Wrap the plates individually with Parafilm (to avoid desiccation) and incubate 6 to 8 days at 27°C.

*If the recombinant virus contains a lacZ gene—e.g., as in recombinants derived from pBlueBacIII (Invitrogen) or pAC360  $\beta$ -Gal (available from Dr. Max Summers; see Alternate Protocol 1)—150  $\mu$ g/ml of Xgal (from 20 mg/ml stock prepared in sterile dimethylformamide; stable for several months at  $-20^\circ\text{C}$ ) should be added to the agarose before it hardens. Recombinant plaques will then develop a bright blue color and will be easily distinguished from nonrecombinants.*

*If a humidified 27°C incubator is used, it is not necessary to wrap the plates with Parafilm.*

*If plaques are not clearly visible after 1 week, the plates can be incubated longer, because plaques continue to form for up to 2 weeks. If no plaques are visible after 2 weeks, the cells were probably plated at too high a density and should be replated at a lower density (between  $1 \times 10^6$  and  $1.3 \times 10^6$  cells/plate).*

6. On plates containing plaques that are well formed and easily visualized, count the number of plaques at each dilution within a set. Calculate the viral titer (pfu/ml).

*Ten plaques at a  $10^{-7}$  dilution or one plaque at a  $10^{-8}$  dilution gives a titer of  $10^8$  pfu/ml.*

7. If difficulties are encountered visualizing plaques, stain with trypan blue as follows. Prepare the trypan blue overlay and dispense 1 ml on plates that have been incubated for 6 to 8 days so that plaques are well formed. Incubate the plates overnight at 27°C to allow the dye to diffuse into the dead cells. Count the number of blue plaques and determine the viral titer.

*The dead cells within a plaque will take up the trypan blue dye but the surrounding live cells will exclude the dye.*

*Another procedure for determining virus titer is by endpoint dilution (O'Reilly et al., 1992). In this method, a series of viral dilutions are made and used to infect cells in microtiter wells. Each well is then scored for the presence or absence of viral infection and a 50% endpoint is determined. However, results from this method are often more difficult to interpret than plaque assays when titrating recombinant virus stocks. Wild-type virus is very easy to score because of the accumulation of occlusion bodies, but recombinant-virus infection can sometimes be difficult to score because of the lack of occlusion bodies.*

## REAGENTS AND SOLUTIONS

*Use deionized, distilled water in all recipes and protocol steps. For common stock solutions, see APPENDIX 2; for suppliers, see APPENDIX 4.*

### **Agarose overlay**

- 40 ml 2× Grace's insect medium, supplemented (Life Technologies)
- 10 ml fetal bovine serum (FBS), heat-inactivated 30 min at 56°C
- 0.25 ml 10 mg/ml gentamicin (Life Technologies; optional)
- 50 ml 1% (w/v) agarose stock (sterile; see recipe)

Mix the first three ingredients together, filter sterilize, and equilibrate to 42°C. Microwave the 1% agarose ~2 min until liquid and equilibrate to 42°C. Mix the two solutions just prior to the end of the 1-hr viral incubation (see Basic Protocol 4, step 3). Use immediately (this solution cannot be stored).

*This is enough for 24 60-mm tissue culture dishes, using 4 ml/plate. The optimal temperature for equilibration is 42°C. If the overlay is too hot, the cells will lyse; if it is too cool the agarose will solidify into clumps, making visual screening difficult.*

### **Agarose stock, 1% (w/v)**

Place 0.5 g SeaKem agarose (FMC Bioproducts) into each of ten 100-ml Wheaton bottles. Add 50 ml distilled water to each bottle, close loosely, and autoclave 20 min. When the solutions have cooled, tighten lids. Store indefinitely at room temperature.

*SeaKem agarose is recommended over SeaPlaque agarose for plaque assays because it can be used at a lower concentration. High concentrations of agarose tend to obscure the plaques or even kill the underlying insect cells.*

### **Extraction buffer**

- 100 mM Tris·Cl, pH 7.5 (APPENDIX 2)
  - 90 mM EDTA
  - 200 mM KCl
- Filter sterilize and store up to 1 year at 4°C

### **Reaction buffer for Klenow fragment**

- 10 mM Tris·Cl, pH 7.5 (APPENDIX 2)
  - 10 mM MgCl<sub>2</sub>
  - 10 mM dATP
- Store up to 2 years at -20 °C

### **Sucrose cushion solution**

25% (w/v) sucrose  
5 mM NaCl  
10 mM EDTA  
Store up to 1 month at 4°C

### **TNM-FH medium**

To 500 ml 1× Grace's insect medium supplemented with yeastolate and lactalbumin hydrolysate (Life Technologies), add 5 ml 10 mg/ml gentamicin (optional), and 50 ml heat-inactivated fetal bovine serum (FBS; 10% final; see below). Filter sterilize. Incubate a 5-ml sample 2 days at 37°C to check sterility; store remainder at 4°C until manufacturer's expiration date.

For medium with 20% DMSO, add sterilized (autoclaved) DMSO to 20% (v/v).

*TNM-FH medium with and without FBS is needed for the protocols throughout this unit. TNM-FH medium including FBS and antibiotics can be obtained from several vendors (e.g., Pharmingen).*

*To heat-inactivate FBS, incubate 30 min at 56°C and store in 50-ml aliquots at -20°C (stable ≥1 year).*

### **Transfection buffer A**

To unsupplemented 1× Grace's insect medium (Life Technologies) add fetal bovine serum (FBS) to 10% and filter sterilize. Prepare fresh for each transfection and store in 10-ml aliquots.

*Transfection buffer A is also sold by Pharmingen.*

### **Transfection buffer B**

25 mM HEPES, pH 7.1  
125 mM CaCl<sub>2</sub>  
140 mM NaCl  
Filter sterilize and store in 10-ml aliquots up to 6 months at 4°C

*Transfection buffer B is also sold by Pharmingen.*

### **Trypan blue overlay**

Prepare a 1% (w/v) trypan blue solution in distilled water and filter sterilize. Microwave 1% agarose (see recipe) 2 min until liquid and equilibrate solution to 42°C. In parallel, equilibrate the 1% trypan blue solution to 42°C. Add 4 ml of the trypan blue solution to 50 ml of 1% agarose and mix well. Use immediately (this solution cannot be stored).

## **COMMENTARY**

### **Background Information**

Although recent research has provided more knowledge of the molecular biology of protein expression in insect cells using the baculovirus system, the ability of a given recombinant virus to produce large quantities of foreign proteins must still be determined empirically. Levels of expression have been reported to vary from 1 to 500 mg of recombinant protein/liter (assuming that 1 liter contains  $2 \times 10^9$  cells). In general, recombinant proteins comprise 1% to 5% of total cell protein.

There are, however, several factors that may influence gene expression in the baculovirus

system that should be taken into account when selecting a transfer plasmid and constructing the recombinant gene. Plasmids derived from the vector pVL941 (e.g., pVL1393 and pBlue-BacIII) contain an ATT in place of the original polyhedrin translation initiation codon ATG. Beames et al. (1991) have reported that translation can initiate at the ATT in these vectors. This results in the fusion of polyhedrin amino-terminal sequences to some of the heterologous proteins produced by these vectors if the foreign gene is cloned into the same reading frame as the ATT. The lengths of the 5' and 3' untranslated regions of foreign genes expressed using

this system have varied greatly. The significance of these sequences for transcriptional and translational efficiencies is unknown, and the standard practice is to keep their length to a minimum. One advantage of this expression system, however, is that it is unnecessary to precisely engineer sequences 5' to the initiation codon for efficient expression, as often must be done for bacterial expression systems, although the presence of an A at -3 (relative to AUG at +1, +2, and +3) may be important (O'Reilly et al., 1992). In addition, the inserted gene does not have to carry its own polyadenylation signal because the polyhedrin-gene polyadenylation signal is present in most expression vectors.

Because no intron-containing genes have been identified for baculovirus, it is recommended that inserted genes be derived either from cDNAs or genomic clones lacking introns. Reports in the literature, however, indicate that proper splicing may occur in some cases. For example, Jeang et al. (1987) reported preferential and proper processing of the small T antigen splicing signals when the SV40 virus early region was cloned into the baculovirus expression vector.

Finally, if the recombinant protein contains a signal peptide, it may be expressed more efficiently in insect cells if it is fused to a heterologous signal peptide in place of the homologous one. The human immunodeficiency virus envelope protein gp120 is expressed and secreted at a much higher level when fused to signal peptides derived from baculovirus proteins (Murphy et al., 1993). Some transfer vectors that contain signal peptide coding regions are available commercially (see Table 16.9.1). However, this approach does not necessarily result in higher levels of protein production for every recombinant protein (Jarvis et al., 1993).

### Critical Parameters and Troubleshooting

*Sf9* cells have a doubling time of 18 to 24 hr in TNM-FH medium/10% FBS and should be subcultured two to three times per week. *Sf9* cells should be grown at 27°C. As carbon dioxide is not essential, the cells can actually be grown on the benchtop as long as room temperature remains within the range of 25° to 30°C. Medium should be equilibrated to room temperature before use. Gentamicin is optional and can be added to the medium if contamination is a problem.

*Sf9* cells are adapted for growth in monolayer or suspension cultures. Trypsin is not

required to detach them from monolayer cultures. *Sf9* cells may be repeatedly transferred between monolayer and suspension cultures without noticeable changes in viability or growth rate. It is easiest to carry cells and maintain their viability when they are carried in suspension rather than in monolayer cultures. A 50-ml culture of cells in a 100-ml spinner flask is routinely carried and used to subculture and seed monolayer cultures when needed.

For preparing viral stocks, low MOIs (e.g., 0.1) should be used. When this is the case the virus goes through multiple rounds of replication and infection and there is less chance for mutant viruses or defective interfering particles to form. When infecting for high levels of protein production, a high MOI (between 5 and 10) is recommended in monolayer cultures. For large suspension cultures (>100 ml), an MOI of 1 or 2 is sufficient. The virus is stable for 6 months at 4°C but must be shielded from light to maintain the titer (Jarvis and Garcia, 1994). Placement of 1 ml of each stock in liquid nitrogen is recommended for long-term storage.

It is highly recommended that linear wild-type DNA be used for cotransfection. This greatly simplifies the screening procedure and saves time in obtaining a pure recombinant viral stock. If circular wild-type DNA is used, it is important to purify the recombinant viral DNA through several rounds of plaque assay.

Degradation by mechanical shearing and by nuclease contamination are the major problems encountered when trying to purify viral DNA from intact virions. Use of wide-mouth 5- or 10-ml pipets or Pasteur pipets with the necks broken off to handle the viral DNA helps to avoid shearing. In addition, tubes containing viral DNA should be mixed by inversion rather than by vortexing when performing phenol extractions and ethanol precipitations, and the purified DNA should be stored at 4°C rather than frozen and thawed.

It is very useful to practice visualizing recombinant plaques using the  $\beta$ -Gal recombinant virus as described in Basic Protocol 4. As mentioned, screening for recombinants is the most time-consuming and variable part of the entire expression system. The cell density at the time of plaquing seems to be the most critical parameter for achieving good plaques in the shortest period of time. Thus, it is helpful to seed duplicate plates at a couple of different cell densities. A perfect plaque assay will yield easily visualized plaques within 6 to 8 days.

## Anticipated Results

### Maintenance and culture of insect cells

When grown at 27°C, healthy insect cells should double every 18 to 24 hr. Healthy, logarithmically growing cells will be maintained in suspension cultures most readily when they are cultured at densities between  $5 \times 10^5$  and  $2 \times 10^6$  cells/ml. Cell viability should be ~97%.

### Cotransfection

After 5 days, 20% to 100% of the cells should be showing signs of infection. Infected cells are of increased size with enlarged nuclei. They stop dividing and do not attach well to the plate. Many of the signs of infection may not be obvious if the transfection efficiency results in a low viral titer. In this case, it is necessary to amplify the virus in order to verify the success of the cotransfection. When generating recombinant baculovirus using wild-type baculoviral DNA (see Alternate Protocol 1), the recombination frequency will be 0.1% to 0.2%. This method requires selection based upon identification of viral occlusion bodies. The direct cloning method (see Alternate Protocol 2) results in ~99% recombinant virus with ~50% containing the foreign gene in the correct orientation.

Plaques can generally be identified within 5 to 10 days post-infection and counted to determine viral titers. When individual plaques are picked to isolate recombinant virus, the resulting viral titer is generally low ( $5 \times 10^5$  pfu/ml) and will need to be amplified several times to produce a high-titer stock.

### Time Considerations

Purification of wild-type viral DNA takes ~7 days to complete. Subcloning and large-scale production of recombinant DNA should take 1 to 2 weeks. The transfection procedure takes 1 day, and the transfection supernatant is harvested after 4 to 5 days. Plaquing takes 1 day, and it generally takes 1 week before the plaques are sufficiently formed to begin screening. Screening takes an additional day. It takes 4 to 5 days from the time of infecting Sf9 cells with a plaque to the time of harvesting the culture supernatant for an expanded virus stock. Purifying recombinants takes from <1 week to 3 weeks, depending on whether linear DNA was used in the transfection and whether several rounds of plaquing are required to purify recombinant virus from wild-type virus.

## Literature Cited

- Beames, B., Braunagel, S., Summers, M.D., and Lanford, R.E. 1991. Polyhedrin initiator codon altered to AUU yields unexpected fusion protein from a baculovirus vector. *BioTechniques* 11:378-383.
- Jarvis, D.L. and Garcia, A. 1994. Long-term stability of baculoviruses stored under various conditions. *BioTechniques* 16:508-513.
- Jarvis, D.L., Summers, M.D., Garcia, A., and Bohlmeier, D.A. 1993. Influence of different signal peptides and prosequences on expression and secretion of human tissue plasminogen activator in the baculovirus system. *J. Biol. Chem.* 268:16754-16762.
- Jeang, K., Giam, C., Nerenberg, M., and Khoury, G. 1987. Abundant synthesis of functional T cell leukemia virus type I p40x protein in eucaryotic cells by using a baculovirus expression vector. *J. Virol.* 61:708-713.
- Lu, A. and Miller, L.K. 1996. Generation of recombinant baculoviruses by direct cloning. *BioTechniques* 21:63-68.
- Maiorella, B., Inlow, D., Shauger, A., and Harano, D. 1988. Large-scale insect cell culture for recombinant protein production. *BioTechnology* 6:1406-1410.
- Murphy, C.L., McIntire, J.R., Davis, D.R., Hodgdon, H., Seals, J.R., and Young, E. 1993. Enhanced expression, secretion, and large-scale purification of recombinant HIV-I gp120 in insect cells using the baculovirus egt and p67 signal peptides. *Protein Expr. Purif.* 4:349-357.
- O'Reilly, D.R., Miller, L.K., and Luckow, V.A. 1992. *Baculovirus Expression Vectors*. W.H. Freeman, New York.

## Key Reference

O'Reilly et al. 1992. See above.

*A guide assembled to aid researchers using the baculoviral expression system, containing detailed protocols for using this system effectively.*

---

Contributed by Cheryl Isaac Murphy  
Aquila Biopharmaceuticals  
Worcester, Massachusetts

Helen Piwnica-Worms  
Washington University School of Medicine  
St. Louis, Missouri

Stefan Grünwald  
Pharmingen  
San Diego, California

William G. Romanow  
Corning Costar  
Portsmouth, New Hampshire

# Expression and Purification of Recombinant Proteins Using the Baculovirus System

UNIT 16.11

This unit describes how to analyze protein expression in cells infected with recombinant baculovirus on a small scale for optimizing protein production (see Basic Protocol 1 and Support Protocols 1 and 2), how to maximize and scale up recombinant protein production (see Basic Protocol 2), and how to purify recombinant proteins (see Basic Protocol 3; see Alternate Protocol). Before proceeding with large-scale expression, it is recommended that the putative recombinants obtained be assayed for their ability to produce the protein of interest. This will exclude the possibility of using a recombinant virus that does not produce the protein of interest, and will, in the long run, save time. Basic Protocol 1 details the expression of protein on a small scale for further analysis. In order to optimize protein expression, it is very important to determine the time course of maximum protein expression (see Support Protocol 1). If the recombinant protein is expressed in small quantities and cannot be visualized without radiolabeling, a metabolic labeling of infected insect cells is advised (see Support Protocol 2). After the recombinant protein expression has been characterized on a small scale, Basic Protocol 2 describes how to scale up protein expression. If purification of the recombinant protein is needed and it is expressed as a fusion protein with either a polyhistidine (6×His) or glutathione-*S*-transferase (GST) tag, it can be purified in a single step according to Basic Protocol 3 or the Alternate Protocol.

## SMALL-SCALE EXPRESSION FOR INITIAL ANALYSIS

In this procedure, *Sf9* cells (UNITS 16.9 & 16.10) are infected with an expanded recombinant virus stock and can be analyzed 2 to 3 days later. The assays employed depend on the nature of the protein being produced. This protocol gives some suggested approaches but is certainly not comprehensive. Screening should be individually tailored to the properties of the protein being overproduced and the availability of detection reagents.

### Materials

- Spodoptera frugiperda* (*Sf9*) cells (UNIT 16.10)
- TNM-FH insect medium (see recipe in UNIT 16.10) containing 10% fetal bovine serum (FBS)
- High-titer recombinant baculovirus stocks (UNIT 16.10)
- Phosphate-buffered saline (PBS; APPENDIX 2)
- 1× SDS sample buffer (UNIT 10.2)
- 60-mm tissue culture plates
- 27°C incubator (humidification optional)
- 15-ml polypropylene centrifuge tubes
- Beckman GPR centrifuge with GH-3.7 rotor (or equivalent), 4°C
- Boiling water bath or 100°C heating block
- Sonicator
- Additional reagents for quantitating protein using the Bradford method (UNIT 10.1) and preparing insect cell cultures and viral stocks (UNIT 16.10)

### Prepare and process cultures

1. Seed  $2.5 \times 10^6$  *Sf9* cells into 60-mm tissue culture plates with 3 ml TNM-FH medium containing 10% FBS. Incubate 1 hr at 27°C to allow cells to attach.

*Prepare one plate for each viral stock to be tested and one plate as an uninfected control.*

**BASIC  
PROTOCOL 1**

**Protein  
Expression**

**16.11.1**

Contributed by Cheryl Isaac Murphy, Helen Piwnica-Worms, Stefan Grünwald,  
and William G. Romanow

*Current Protocols in Molecular Biology* (1997) 16.11.1-16.11.12  
Copyright © 1997 by John Wiley & Sons, Inc.

Supplement 38

BEQ 1016  
Page 267

2. Replace the medium with fresh TNM-FH/10% FBS medium and add 0.1 ml high-titer baculovirus stock to the appropriate plates at an MOI of 1 to 10. Incubate 3 days at 27°C.
3. Harvest cells by gently dislodging them from the plates and transfer cells and culture medium to 15-ml polypropylene centrifuge tubes.
4. Centrifuge 10 min at 1000 × g (2000 rpm in a GH-3.7 rotor), 4°C.

*If the protein of interest is a secreted protein*

- 5a. Transfer the culture supernatants to new tubes.
- 6a. Determine the protein concentrations in the supernatants using the Bradford method (UNIT 10.1). Proceed to analysis (step 7).

*Supernatants may be frozen up to several months at -80°C.*

*If the protein of interest is an intracellular protein*

- 5b. Discard the supernatants. Rinse cells by resuspending the cell pellets gently in PBS, centrifuging again as in step 4, then discarding the supernatants.
- 6b. Add 500 µl of 1× SDS sample buffer to each pellet and boil 5 to 10 min by placing the tube in a boiling water bath or 100°C heating block. Sonicate samples if they are too viscous because of the presence of DNA. Continue to sonicate until viscosity clears, then determine the protein concentration in each sample using the Bradford method. Proceed to analysis (step 7).

*Sonication times will vary with individual sonicators.*

*Alternatively, lyse cell pellets in 0.5 ml of an appropriate lysis buffer (which may differ according to cell type; an example would be the insect cell lysis buffer in Reagents and Solutions) supplemented with protease inhibitors. Lysis buffers containing EDTA must not be used with 6×His fusion products. Microcentrifuge 10 min at 4°C to clarify the lysates and transfer supernatants to new tubes. Add 100 µl of each lysate to 100 µl of 2× SDS sample buffer and boil 3 min in boiling water bath. Freeze remaining lysate up to several months at -80°C.*

### Analyze proteins

7. Analyze the proteins in each sample by one of the following methods.
  - a. *Immunoblotting* (UNIT 10.8): Load 20 to 40 µg total cell protein per lane on a one-dimensional SDS-polyacrylamide gel. Remember to include the uninfected control.
  - b. *Coomassie brilliant blue staining* (UNIT 10.6): Load 20 to 40 µg total cell protein per lane on a one-dimensional SDS-polyacrylamide gel. If the recombinant virus is not pure, recombinant protein will be detected only if it is produced at very high levels in the infected cells.
  - c. *Functional assays*: Use any assay that is typically used to monitor the protein of interest—e.g., mobility-shift DNA-binding assays (for a DNA-binding protein; UNIT 12.2), in vitro kinase assays (for a protein kinase), nucleotide-binding assays (for a protein that binds nucleotides), or thymidine-incorporation assays (for a protein that is a growth factor).
  - d. *Metabolic labeling of recombinant proteins*: See Support Protocol 2.

*If there are no easy assays for monitoring the recombinant protein produced by the baculovirus, then the putative recombinants should be monitored for the presence or absence of the foreign gene. A simple dot hybridization technique is given in Summers and Smith (1987); alternatively PCR amplification can be used (Chapter 15 of this manual and O'Reilly et al., 1992). Several companies (e.g., Invitrogen and Clontech) sell PCR primers that will work for most baculovirus vectors.*

- Interpret results to identify which of the putative recombinant stocks is an actual recombinant that produces the desired protein. Plaque-purify recombinants so they are free from any contaminating wild-type virus (if they were not produced with a linearized baculoviral DNA; see *UNIT 16.10*). Prepare a large viral stock and titer the recombinant virus (*UNIT 16.10*).

## DETERMINING TIME COURSE OF MAXIMUM PROTEIN PRODUCTION

Because expression of the recombinant protein is regulated by the polyhedrin promoter, which is activated very late in the lytic cycle of the virus, the recombinant protein will be expressed late as well. Recombinant proteins are usually detected between 15 and 24 hr postinfection and accumulate until ~40 hr postinfection, at which time their accumulation levels off. Because individual proteins display differences in their stability within insect cells, it is recommended that the time course of protein accumulation be charted for each protein expressed using this system. The following protocol describes how to determine when an intracellular recombinant protein is maximally produced by harvesting and analyzing cells at various times after infection.

### *Additional Materials (also see Basic Protocol 1)*

Wild-type baculovirus (available from Dr. Max D. Summers; see *UNIT 16.10*, Alternate Protocol 1)

- Seed  $3 \times 10^6$  Sf9 cells/plate into fifteen 60-mm tissue culture plates, each containing 3 ml TNM-FH medium with 10% FBS. Incubate 1 hr at 27°C to allow cells to attach, then infect seven plates with wild-type baculovirus and seven plates with recombinant virus, each at an MOI of 10. Leave one plate as an uninfected control.

*Alternatively, Sf9 cells can be cultured in suspension in three 100-ml spinner flasks. When cells reach a density of  $1.5 \times 10^6$  cells/ml, infect one flask with recombinant virus and one with wild-type virus, leaving one as an uninfected culture. Use an MOI of 1 to 2.*

- Harvest cells at various times (from ~15 to 72 hr) postinfection by transferring cells and culture supernatants to centrifuge tubes and centrifuging 10 min at  $1000 \times g$  (2000 rpm in a GH-3.7 rotor), 4°C. Harvest the uninfected cells at 15 hr postinfection.

*If cells are growing in suspension, remove 2-ml aliquots at each time point and process the cells and supernatants in the same way as for the monolayer cultures discussed here.*

- Process and analyze the cells (if the recombinant protein is not secreted) or supernatants (if the recombinant protein is secreted) as in Basic Protocol 1.

*When staining with Coomassie brilliant blue (see Basic Protocol 1, step 9b), look for a protein that appears as a function of time postinfection with the recombinant virus but not with the wild-type virus. The protein must be reasonably abundant for this method to be successful.*

## METABOLIC LABELING OF RECOMBINANT PROTEINS

Metabolic labeling in vivo is a sensitive way to detect recombinant proteins, because at the time the recombinant protein is expressed, host protein synthesis is essentially terminated. Thus, all label is incorporated into late-viral-specific proteins, including the protein of interest. The most commonly used procedure for radiolabeling proteins is the incorporation of [<sup>35</sup>S]methionine and [<sup>35</sup>S]cysteine, both of which are essential amino acids. For better results, the intracellular pool of these two amino acids should be depleted prior to radiolabeling. This can be achieved by preincubating the cells in methionine/cysteine-free medium for 30 min. The efficiency of incorporation depends on the number of methionines and cysteines in the particular protein of interest. After labeling, the cells are lysed. The proteins are resolved by SDS-PAGE and visualized by autoradiography.

### SUPPORT PROTOCOL 1

### SUPPORT PROTOCOL 2

#### Protein Expression

#### 16.11.3

**Additional Materials** (also see *Basic Protocol 1*)

Wild-type baculovirus (available from Dr. Max D. Summers; see *UNIT 16.10*, Alternate Protocol 1)

Methionine-free or methionine-free/cysteine-free Grace's insect cell culture medium (Life Technologies)

EXPRE<sup>35</sup>S<sup>35</sup>S, containing [<sup>35</sup>S]methionine and [<sup>35</sup>S]cysteine (>1000 Ci/mmol; Du Pont NEN)

Additional reagents and equipment for one-dimensional SDS-PAGE (*UNIT 10.2*) and autoradiography (*APPENDIX 3A*)

1. Seed  $2.5 \times 10^6$  cells into 60-mm tissue culture plates containing 3 ml TNM-FH medium with 10% FBS. Prepare one plate to be infected with each putative recombinant virus and one control plate to be infected with wild-type baculovirus.
2. Incubate 1 hr at 27°C to allow cells to attach. Aspirate medium, then add 1 ml recombinant virus or 1 ml of medium containing wild-type virus at an MOI of 5 to 10. Incubate 1 hr at room temperature.
3. Remove the medium from each plate by aspiration. Add 3 ml TNM-FH/10% FBS medium to the cells and incubate 24 to 48 hr at 27°C.
4. Carefully remove medium from each plate, then rinse cells once with methionine-free or methionine-free/cysteine-free medium. Add 1 ml of methionine-free or cysteine-free medium to each plate. Incubate cells 30 min at 27°C, then add 0.25 to 0.5  $\mu$ Ci of EXPE<sup>35</sup>S<sup>35</sup>S per plate and incubate 3 to 4 hr at 27°C.

*It is important to hold the plates at an angle and remove and add medium at one corner so as not to dislodge the cells from the monolayer.*

5. Transfer cells and culture supernatant from each plate to a separate 15-ml polypropylene centrifuge tube and centrifuge 10 min at  $1000 \times g$  (2000 rpm in a GH-3.7 rotor), 4°C.
6. Process and analyze the cells (if the recombinant protein is not secreted) or the supernatant (if the recombinant protein is secreted) according to the appropriate procedures in *Basic Protocol 1* (see *Basic Protocol 1*, steps 5a or 5b, 6a or 6b, and 7).

*If an antibody is available, it is recommended that the labeled lysates be immunoprecipitated (UNIT 10.16) prior to boiling in SDS sample buffer and resolution by SDS-PAGE. Immunoprecipitation will help detect the recombinant protein if it comigrates with a labeled host or late-viral-specific protein.*

*Polyhedra (UNIT 16.9) are solubilized only under very alkaline conditions (0.1 M final NaOH concentration). Without prior disruption under alkaline conditions, <10% of polyhedra will be solubilized in SDS sample buffer.*

7. Visualize proteins by autoradiography (*APPENDIX 3A*). Inspect the autoradiogram for protein of the expected molecular weight that appears in cells infected with recombinant baculovirus but not with wild-type baculovirus.

## LARGE-SCALE PRODUCTION OF RECOMBINANT PROTEINS

This protocol describes how to maximize and scale up recombinant protein production in *Sf9* cells. The cells are grown in suspension in serum-free medium in 1- to 10-liter spinner flasks (Techne or Bellco). They are then infected with recombinant virus and harvested and analyzed at the time of optimum protein accumulation (see Support Protocol 1).

### Materials

*Spodoptera frugiperda* (*Sf9*) cells (UNIT 16.10)

Serum-free insect cell culture medium (e.g., BaculoGold medium from Pharmingen, *Sf*-900 II from Life Technologies, or ExCell 401 from JRH Biosciences)

High-titer recombinant baculovirus (UNIT 16.10)

1- to 10-liter spinner flasks (Techne or Bellco)

Two-port cap assemblies for spinner flasks (Techne or Bellco)

Silicone tubing (Cole-Palmer) with  $\frac{3}{16}$ -in. (0.48-cm) inner diameter (i.d.),  $\frac{5}{16}$ -in. (0.8-cm) outer diameter (o.d.), and  $\frac{1}{16}$ -in. (0.16-cm) wall

0.2- $\mu$ m filter units (Millipore)

4-in. (10.16-cm) cable ties (Cole-Palmer)

Tension tool (Cole-Palmer)

Stir plate for multiple spinner flasks (Techne or Bellco)

27°C incubator

Air-supply pump (Bellco)

Additional reagents and equipment for preparing insect cell cultures and viral stocks (UNIT 16.10)

1. Grow *Sf9* cells in suspension culture and adapt to serum-free medium (see UNIT 16.10, Basic Protocol 1).
2. Prepare spinner flasks to be used for scale-up of *Sf9* cells by attaching the appropriately sized two-port cap to one side arm and a plain cap to the other sidearm. Put a short (~6-in. or 15-cm) piece of tubing on the air-vent port and attach a filter to the end. Secure the tubing to the port and to the filter with cable ties using the tension tool.

*Refer to Figure 16.11.1 for these procedures.*

3. Put a longer piece of tubing (1 to 2 feet or 30 to 60 cm) on the air-supply port and attach a 0.2- $\mu$ m filter unit to the end. Secure with cable ties. Attach another piece of tubing to the other end of the filter with a cable tie. Cover the end of the tubing with aluminum foil.

*The length of the silicone tubing attached to the air-supply port will depend on the distance between the sidearm and the air-supply pump in the incubator.*

*Several sizes of two-port cap assemblies are available for Bellco spinner flasks. The smallest size fits the 1-liter flask and the next larger size fits the 3-liter flask. The largest size fits the 6-, 8-, and 15-liter flasks.*

4. Loosen the cap on the side arm opposite to the two-port assembly a quarter turn and autoclave flask 1 hr.
5. Seed the autoclaved flask with *Sf9* cells adapted to serum-free medium (from step 1). Fill the flask to between half full and full (e.g., 1.5 to 3 liters in a 3-liter flask), adding enough serum-free medium to make a final cell density of  $5\text{--}6 \times 10^5$  cells/ml.

*If enough cells are available, flasks can be seeded at densities up to  $1.5 \times 10^5$  cells/ml.*

### 16.11.5

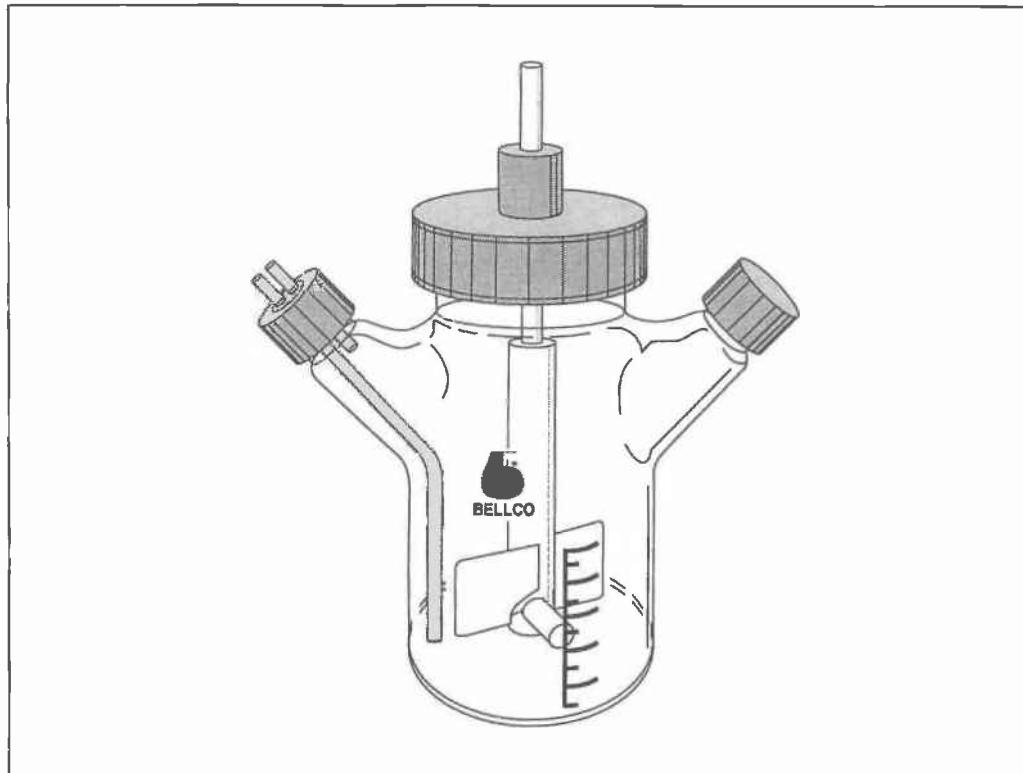

**Figure 16.11.1** Bellco spinner flask with two-port cap assembly.

6. Place the flask on a stir plate for spinner flasks in a 27°C incubator. Set the stir speed at 80 rpm. Remove the aluminum foil from the air-intake tube and attach the end of the tube to the air-supply pump. Turn on the pump and set to the lowest setting.

*A flow rate of 500 to 700 ml/min works well with these flasks; the larger flasks require a higher flow rate than the smaller ones. It is recommended that the pump flow rate be measured empirically before hooking it up to the flask or that a flow meter be attached between the pump and the flask.*

7. Grow the cells to a density of  $\sim 1.5 \times 10^6$  cells/ml. Working in a laminar-flow hood, add virus at a multiplicity of infection (MOI) of 1 to 2 directly to the flask through the side arm.
8. Place the flask on the magnetic stir plate at 27°C and connect the air supply. Incubate the culture for the optimal amount of time determined in Support Protocol 1.
9. Process the supernatant for secreted proteins or the cells for intracellular proteins.

*There are many protein purification methods available and the choice of which ones to use depends on the nature of the recombinant protein expressed. For additional information see Chapter 10 or Coligan et al. (1997).*

**PURIFICATION OF RECOMBINANT PROTEINS CONTAINING A POLYHISTIDINE (6×HIS) TAG**

The pAcHLT-A-, B-, and C- transfer vectors (Pharmlingen) and the pBlueBacHis -A, -B, and -C vectors (Invitrogen) contain DNA that encodes an N-terminal tag of six histidine residues, followed by an extended multiple cloning site (MCS). The MCS is in a different reading frame in each of the vectors to simplify cloning. The expressed recombinant protein will be a 6×His fusion protein suitable for affinity purification on Ni-NTA agarose. Approximately 1 to 2 mg of 6×His recombinant fusion protein is routinely obtained per liter of insect cell culture.

**Materials**

Insect cell lysis buffer (see recipe) containing 1× protease inhibitors (see recipe for 50×)

Ni-NTA agarose (Qiagen)

6×His wash buffer (see recipe)

6×His elution buffer (see recipe) containing imidazole as either a step or linear gradient

Beckman GPR centrifuge with GH-3.7 horizontal rotor (or equivalent), 4°C

Sorvall centrifuge and SS-34 rotor (or equivalent) or 0.2 μm filter

Suitable chromatography column

Additional reagents and equipment for preparing insect cell cultures and viral stocks (UNIT 16.10) and quantitation of protein by absorbance spectrometry (APPENDIX 3D)

**Harvest and lyse cells**

1. Infect the desired amount of cells (e.g.,  $5 \times 10^6$  cells per 100-mm plate) with the amplified recombinant virus at an MOI of 5 to 10. Cultivate 3 to 5 days and examine for typical signs of infection (UNIT 16.10).
2. Harvest the cells and supernatant from infected plate(s) by gently spritzing the cells with a sterile pipet to resuspend. Transfer to a centrifuge tube.
3. Centrifuge 10 min at  $1000 \times g$  (2000 rpm in a GH-3.7 rotor), 4°C. If the protein of interest is a secreted protein, transfer the supernatant to a new tube and proceed to purification (step 6). If the protein of interest is an intracellular protein, discard the supernatant, then rinse the cells by resuspending the cell pellet gently in PBS, repeating the centrifugation, and discarding the supernatant.
4. Lyse the cells by adding 1 ml of insect cell lysis buffer containing 1× protease inhibitors for every  $1 \times 10^7$  cells and incubating 45 min on ice.

*Choice of lysis buffer may vary with cell type, but EDTA-containing lysis buffers must not be used with 6×His fusion proteins.*

5. Clarify the lysate by centrifuging 30 min at  $40,000 \times g$  (18,000 rpm in an SS-34 rotor), 4°C to pellet the cellular debris or filter the lysate through a 0.2-μm filter.
6. Gently resuspend the Ni-NTA agarose and pour into a suitable chromatography column. Allow the beads to settle and the column to drain, then wash twice with 3 to 5 column volumes of 6×His wash buffer to remove the ethanol preservative. Allow the column to drain.

*One ml of Ni-NTA agarose will bind ~5 to 10 mg of 6×His fusion protein.*

7. Apply clarified lysate to column. Adjust the column flow rate to a maximum of 5 column volumes per hour.

*Keep the flowthrough fraction to run on SDS-PAGE (UNIT 10.2) in case the binding capacity of the Ni-NTA agarose was exceeded.*

8. Wash the column with 10 bed volumes of 6×His wash buffer and allow the column to drain while periodically monitoring the  $A_{280}$ . Repeat washing (~4 times) until the  $A_{280}$  of the column effluent is <0.01. Discard the washes.
9. Add 3 bed volumes of the 6×His elution buffer (including imidazole either as a step or a linear gradient) to the column. Adjust the column flow rate to a maximum of 1 ml/min per ml of resin beads. Allow the column to drain completely while collecting the eluted fractions.

*The optimal amount of imidazole (0.1 M to 0.5 M) needed for elution will vary on the basis of the properties of the bound protein, and should be empirically determined by the researcher.*

*Pharmingen has also introduced the BioColors-His baculovirus transfer vector set, which allows the production of a fusion protein consisting of the desired gene product along with one of several derivatives of the *Aquorea victoria* green fluorescent protein (GFP; see UNIT 9.7C) and a histidine affinity tag. Under UV light, such a recombinant fusion protein can be visualized during the entire purification process, which facilitates the establishment of an optimized purification procedure.*

#### ALTERNATE PROTOCOL

#### PURIFICATION OF RECOMBINANT PROTEINS CONTAINING A GST TAG

Several baculovirus vectors are commercially available that allow the expression of glutathione-S-transferase (GST)-tagged fusion proteins, which greatly facilitate the purification of recombinant proteins. Pharmingen's pAcGHLT-A-, -B, and -C transfer vectors, for example, encode N-terminal 6×His and GST tags followed by an extended MCS. The MCS is in a different reading frame in each of the vectors to simplify cloning. Because the GST vectors also contain a 6×His sequence, the expressed recombinant protein will be a 6×His-containing GST fusion protein. This feature allows affinity purification using either glutathione agarose beads or Ni-NTA agarose. A thrombin cleavage site following the affinity tags allows for the proteolytic cleavage of the GST-6×His fusion partner from the protein of interest.

The GST purification method is based on the remarkable selectivity and affinity of recombinant proteins equipped with a GST affinity tag toward glutathione immobilized on a resin. The expressed GST fusion proteins are authentically processed, and may be purified without the use of detergents under completely nondenaturing conditions. Purifications to >90% homogeneity are easily achieved in a single step by affinity chromatography using glutathione agarose beads. The affinity of GST for glutathione is so strong that it allows a highly efficient separation of GST fusion proteins from contaminating polypeptides even under nondenaturing conditions.

Although addition of a 6×His or GST tag to a recombinant protein may greatly simplify purification, these methods do not work for all proteins and should be tried on a small scale first.

#### *Additional Materials (also see Basic Protocol 3)*

- Glutathione agarose beads (Pharmingen or Sigma)
- PBS wash buffer (Pharmingen)
- GST elution buffer (see recipe)
- 50 mM Tris·Cl, pH 8.0 (APPENDIX 2)
- Thrombin, bovine (e.g., Sigma or Boehringer Mannheim)
- Additional reagents and equipment for dialysis (APPENDIX 3C)

### ***Purify GST fusion protein***

1. Prepare clarified solution of recombinant protein (see Basic Protocol 3, steps 1 to 5).
2. Gently resuspend the glutathione agarose beads and pour slurry into a suitable chromatography column. Allow the beads to settle and the column to drain. Wash twice with 3 to 5 bed volumes of PBS wash buffer to remove the ethanol preservative, then allow the column to drain.
3. Apply the clarified solution of recombinant proteins to the column. Adjust column flow rate to a maximum of 5 ml/min per ml of beads.

*Keep the flowthrough fraction to run on SDS-PAGE (UNIT 10.2) in case the binding capacity of the glutathione beads was exceeded.*

3. Wash the column twice with 5 bed volumes of PBS wash buffer. Allow the column to drain and discard the washes.
4. Add 3 bed volumes of GST elution buffer to the column. Adjust the column flow rate to a maximum of 1 ml/min per ml of beads. Allow the column to drain completely while collecting the eluted fraction.

*The addition of 150 mM NaCl, 5 mM CaCl<sub>2</sub> (or for some proteins 5 mM MgCl<sub>2</sub>), and 0.1% 2-mercaptoethanol is optional but may be required for the solubility of some proteins.*

5. Remove the free glutathione by dialysis (APPENDIX 3C) for  $\geq 4$  hr against 100 vol of 50 mM Tris·Cl (pH 8.0) at 4°C. Change dialysis buffer after 2 hr.

### ***Perform thrombin cleavage***

6. Add 200  $\mu$ g (10 thrombin units) of bovine thrombin per mg of purified GST or 6×His fusion protein containing a thrombin cleavage site.
7. Mix, then incubate at room temperature up to 12 hr.

*In many cases a 20- to 60-min incubation will be sufficient.*

8. Add 2 vol of a 50% (v/v) slurry of glutathione agarose beads at the end of the cleavage reaction.

*This directly removes GST and uncleaved GST fusion protein. Similarly, 6×His and uncleaved 6×His fusion protein may be removed by directly adding Ni-NTA agarose at the end of the cleavage reaction.*

9. Incubate 30 min at 4°C, then centrifuge 10 min at 5000  $\times$  g (2250 rpm in an SS-34 rotor), 4°C. Retain the supernatant and freeze at  $-80^{\circ}\text{C}$ .

*The supernatant will contain the purified protein as well as thrombin and can be stored frozen at  $-80^{\circ}\text{C}$ . Some proteins may require the addition of BSA or glycerol (50% final concentration) for stability.*

*Thrombin cleaves in 50 mM Tris·Cl buffer and does not require specific metal ions for its activity (Haun and Moss, 1993; Wu et al., 1992). However, Guan and Dixon (1991) have recommended using a buffer containing 50 mM Tris·Cl (pH 8.0), 150 mM NaCl, 2.5 mM CaCl<sub>2</sub>, and 0.1% 2-mercaptoethanol for efficient cleavage.*

*An efficient thrombin cleavage primarily depends on the sequence of the thrombin consensus site and the three-dimensional structure surrounding that site. The thrombin cleavage consensus site is XXP(K/R)\*BB, where X stands for hydrophobic apolar amino acids, P stands for proline, (K/R) symbolizes that both lysine and arginine work in this position, and B stands for nonacidic amino acids. The (\*) symbolizes the cleavage position, which is at the carboxy-terminal side of the arginine or the lysine residue. The thrombin site used in the pAcGHLT and pAcHLT vectors is LVPR\*GS. A BamHI site codes for the amino acids GS within the cloning site and allows the insertion of the desired gene within the thrombin coding sequence. This cloning strategy allows release of nearly authentic proteins after thrombin cleavage.*

## REAGENTS AND SOLUTIONS

Use deionized, distilled water in all recipes and protocol steps. For common stock solutions, see APPENDIX 2; for suppliers, see APPENDIX 4.

### **GST elution buffer**

Dissolve 42 mg of reduced dry glutathione in 40 ml of 50 mM Tris-Cl, pH 8.0 (APPENDIX 2). Divide into small aliquots and store up to 6 months at  $-20^{\circ}\text{C}$ .

### **6×His elution buffer**

50 mM sodium phosphate, pH 8.0 (APPENDIX 2)  
300 mM NaCl  
10% (v/v) glycerol  
Imidazole to make either a step or linear gradient for elution  
Prepare using distilled water and filter sterilize  
Store up to 6 months at  $4^{\circ}\text{C}$ .

*A maximum concentration of 0.5 M imidazole is recommended for the final elution. The concentration of imidazole should be determined empirically by the researcher.*

### **6×His wash buffer**

50 mM sodium phosphate, pH 8.0 (APPENDIX 2)  
300 mM NaCl  
10% (v/v) glycerol  
Prepare using distilled water and filter sterilize  
Store up to 6 months at  $4^{\circ}\text{C}$ .

*For a more stringent wash, the pH may be adjusted to 6.0 and 0.8 to 40 mM imidazole may be added. The concentration of imidazole should be determined empirically by the researcher.*

### **Insect cell lysis buffer, 1×**

10 mM Tris-Cl, pH 7.5 (APPENDIX 2)  
130 mM NaCl  
1% (v/v) Triton X-100  
10 mM NaF  
10 mM sodium phosphate, pH 7.5 (APPENDIX 2)  
10 mM sodium pyrophosphate  
Prepare using distilled water and filter sterilize  
Store up to 6 months at  $4^{\circ}\text{C}$ .  
Add 50× protease inhibitor cocktail (see recipe) to 1× before use

### **Protease inhibitor cocktail, 50×**

Prepare in 100% ethanol  
800  $\mu\text{g/ml}$  benzamidine  
500  $\mu\text{g/ml}$  phenanthroline  
500  $\mu\text{g/ml}$  aprotinin  
500  $\mu\text{g/ml}$  leupeptin  
500  $\mu\text{g/ml}$  pepstatin A  
50 mM PMSF  
Vortex to resuspend insoluble constituents before use  
Store up to 6 months at  $-20^{\circ}\text{C}$ .

## COMMENTARY

### Background Information

There are many protein purification methods available, and the choice of which to use depends on the nature of the recombinant protein expressed (for additional information see Chapter 10). Suspension (spinner) cultures are often more convenient to use for protein expression than monolayer cultures and densities of up to  $10^7$  cells/ml with >97% viability can be achieved. Suspension cultures are also preferred when growing large quantities of cells (e.g., to prepare large viral stocks or large quantities of recombinant protein), because the entire process can be carried out in one flask. For small-scale procedures, by contrast, monolayer cultures are preferred because they seem less susceptible to contamination and can more easily be assessed to monitor the progress of viral infections. Monolayer cultures are absolutely required for transfections as well as for plaquing viral supernatants, and they are also preferred for preparing viral stocks or producing recombinant protein.

Most cell lines are readily adaptable to serum-free medium when in suspension. The use of serum-free medium has several advantages. First, cells can be grown to higher cell densities in serum-free medium. Second, serum-free medium is more consistent and less expensive than serum-supplemented medium. In addition, serum-free medium has a low protein content, which aids in the purification of secreted recombinant proteins. It should be determined empirically which cell line and medium formulation is most productive for the particular recombinant protein of interest. *Spodoptera frugiperda* (*Sf9*, *Sf21*) cells grown in serum-free medium are more sensitive to centrifugation, stick more tightly to plasticware, undergo a growth lag when seeded at too low a density, and cannot be passaged more than ~50 times.

In regard to purification, secreted recombinant proteins are much easier to purify than nonsecreted proteins, because the ratio between recombinant protein and host proteins in the medium is much higher than in lysates, especially when protein-free medium has been used. The general strategy for purifying protein from the medium depends on the nature of the recombinant protein. If an antibody against the desired protein is available in large quantities, it can be used for affinity purification. Otherwise conventional ion-exchange chromatography may perform equally well.

### Critical Parameters

The efficiency of heterologous gene expression in the baculovirus system can differ 1000-fold as a result of the intrinsic nature of the gene and the encoded protein. Modifying the heterologous gene will generally influence gene expression by only 2- to 5-fold. Researchers should not feel compelled to modify their gene excessively. For some general rules regarding the improvement of gene expression, see O'Reilly et al. (1992). When expressing protein, a time-course experiment should be conducted to determine peak protein production.

To optimize for protein production, it is recommended that log-phase *Sf9* cells be infected at high multiplicity of infections (MOIs)—e.g., 5 to 10 for monolayer culture and 1 to 2 for suspension culture. Cells to be infected should be >97% viable. Use of high-quality media and FBS also seems to contribute to high protein yields.

The most common method for radiolabeling protein involves incorporating [ $^{35}$ S]methionine or [ $^{35}$ S]cysteine. To improve results, the intracellular pool of these essential amino acids should be depleted prior to radiolabeling by incubating the cells in methionine/cysteine-free medium. If an antibody is available, the labeled lysate should be immunoprecipitated to help detect the recombinant protein if it comigrates with a labeled host protein.

To maximize large-scale production of recombinant proteins, *Sf9* cells should be grown in suspension in serum-free medium. Flasks should remain <50% full, or be vented, to ensure proper oxygenation. Cells should be grown to a density of  $1.5 \times 10^6$  cells/ml before infecting at an MOI of 1 to 2.

Purification of recombinant proteins can be simplified by expressing them with either a GST or 6×His tag. When purifying these proteins via affinity chromatography, the flow-through fractions should be retained for analysis by SDS-PAGE. Analysis of these fractions may help in troubleshooting poor affinity binding.

The addition of a 6×His or GST tag to a recombinant protein may greatly simplify purification; however, these methods do not work for all recombinant proteins and should be tried on a small scale first.

### Anticipated Results

When expressing proteins in the baculovirus system one can expect, typically, to produce up

to 1 to 5 mg of protein per liter of insect-cell culture. However, it is extremely important to note that gene expression can vary 1000-fold as a result of the intrinsic nature of the protein. Recombinant protein levels can vary from 1% to 50% of the total insect-cell protein. When using an MOI >1, it is expected that most cells in the culture will become infected at the same time and thus produce protein within the same time frame. A time course can be run to test for peak protein production. Cells infected during log-phase growth with a high surface-to-volume ratio to allow for proper gas exchange will produce protein optimally.

Approximately 1 to 2 mg of 6×His and GST fusion protein are routinely obtained per liter of insect-cell culture. Affinity purifications to >90% homogeneity are easily achieved using single-step affinity purification with Ni-NTA or glutathione agarose.

### Time Considerations

It takes 1.5 to 2 weeks to obtain a spinner culture from a frozen vial of Sf9 cells. A viral stock can be obtained in ~4 days and plaqued in 1 day. It takes ~1 week before the plaques are formed and ready to be counted.

It takes an additional 2 days to infect Sf9 cells to obtain cells or medium for protein analysis. Analyzing for the recombinant protein after harvesting should take 1 to 3 days. Finally, it will take ~4 days to complete the time course and another 2 to 3 days to harvest and analyze the infected cell pellets or culture supernatants.

### Literature Cited

Coligan, J.E., Dunn, B.M., Ploegh, H.L., Speicher, D.W., and Wingfield, P.T. (eds.) 1997. *Current Protocols in Protein Science*. John Wiley & Sons, New York.

Guan, K. and Dixon, J.E. 1991. Eukaryotic proteins expressed in *Escherichia coli*: An improved thrombin cleavage and purification procedure of fusion proteins with glutathione S-transferase. *Anal. Biochem.* 192:262-267.

Haun, R.S. and Moss, J. 1993. Ligation-independent cloning of glutathione S-transferase fusion genes for expression in *Escherichia coli*. *Gene* 112:37-43.

O'Reilly, D.R., Miller, L.K., and Luckow, V.A. 1992. *Baculovirus Expression Vectors*. W.H. Freeman, New York.

Summers, M.D. and Smith, G.E. 1987. *A manual of methods for baculovirus vectors and insect cell culture procedures*. Texas Agricultural Experiment Station Bulletin No. 1555. College Station, Texas.

Wu, H., White, G.C., Workman, E.F., Jenzano, J.W., and Lundblad, R.L. 1992. Affinity chromatography of platelets on immobilized thrombin: retention of catalytic activity by platelet-bound thrombin. *Thrombosis Res.* 67:419-427.

### Key Reference

O'Reilly et al., 1992. See above.

*A laboratory manual that will aid researchers in the expression and purification of recombinant proteins using the baculovirus system.*

---

Contributed by Cheryl Isaac Murphy  
Aquila Biopharmaceuticals  
Worcester, Massachusetts

Helen Piwnica-Worms  
Washington University School of Medicine  
St. Louis, Missouri

Stefan Grünwald  
Pharmingen  
San Diego, California

William G. Romanow  
Corning Costar  
Portsmouth, New Hampshire

# EXPRESSION OF PROTEINS IN MAMMALIAN CELLS

## Overview of Protein Expression in Mammalian Cells

The techniques of gene isolation, modification, and transfer into appropriate host cells have provided a powerful means to study gene expression and to evaluate protein structure and function. These techniques make it possible to produce large amounts of proteins that previously could be isolated in only minute quantities and allow the generation of proteins with specific, designed alterations.

As described elsewhere in this manual (Chapter 9), mammalian cells are often used as hosts for expression of genes obtained from higher eukaryotes because the signals for synthesis, processing, and secretion of these proteins are usually recognized. Mammalian expression of foreign genes has been used for many purposes including: (1) confirmation that genes isolated by different approaches can direct the synthesis of a desired protein, (2) evaluation of the effect of specific mutations introduced into genes, (3) direct isolation of genes based on screening or selecting recipient cells for production of a particular protein, (4) production of large amounts of proteins that normally are available in only limited quantity, and (5) analysis of physiologic consequences of expression of specific proteins.

The units that follow in Sections III and IV describe three vector systems or strategies for introducing foreign genes into mammalian cells (additional transfection methods can be found in *UNITS 9.1-9.4*). The first method relies upon COS cells for rapid, transient expression of protein from specific vectors (*UNIT 16.13*). The second method relies upon Chinese hamster ovary (CHO) cells; in this procedure, a targeted gene is cotransfected with a selectable marker, becomes stably integrated into the host cell chromosome, and is subsequently amplified (*UNIT 16.14*). The third system relies upon vaccinia viral vectors in a transient expression system (*UNITS 16.15-16.19*). The systems described in these units differ in the ways in which DNA is introduced into the cell, in the particular vectors used with each system, and in their suitability for particular cell types.

The criteria for choosing a certain system include these considerations: whether DNA can be introduced directly by transfection methods or needs to be introduced by viral-mediated transfer, the identity of the control elements that can direct efficient mRNA expression and protein synthesis, and whether a particular host cell is appropriate for expression of the gene of interest. If it is necessary to produce a large amount of protein for a long period of time, the CHO system should be utilized. When transient expression is appropriate, the choice of which system to use depends upon the particular experiment. When a high transfection efficiency is necessary, the vaccinia system is appropriate because every cell can be infected with the virus and gene of interest; however, this system suffers from the disadvantage that the cells die within one to two days. If a lower transfection efficiency is sufficient and if it is desirable that the cells continue to grow for several days, COS cells should be used.

### VIRAL-MEDIATED GENE TRANSFER

Many viruses that infect mammalian cells have evolved mechanisms to usurp the protein synthesis machinery of the host to produce their viral proteins. The ability to engineer the genetic material of these viruses has made it possible to place desired coding regions under the control of the viral expression elements and to produce infectious virus particles that direct high levels of foreign gene expression. Viral-mediated gene transfer provides a convenient, efficient means to introduce foreign DNA into the majority of recipient cells. In addition, for many viruses, viral replication yields multiple copies of template DNA that can serve to increase the total amount of transcript made by the foreign gene.

Because some viruses can infect a range of cell types derived from different species, viral-mediated gene transfer often allows the convenient introduction of foreign genes into a variety of different cells. Representative

**Table 16.12.1** Expression Levels and Uses for Different Mammalian Cell Expression Systems<sup>a</sup>

Cell line	Expression method	Typical expression level (µg/ml)	Primary use
<i>Monkey cells</i>			
CV1	SV40 virus infection	1-10	Expression of wild-type and mutant proteins
COS	Transient DNA/DEAE-dextran transfection	1	Cloning by expression in mammalian cells; rapid characterization of cDNA clones; expression of mutant proteins
CV1	Transient DNA/DEAE-dextran transfection	0.05	
<i>Murine fibroblasts</i>			
C127	BPV stable transformant	1-5	High-level constitutive protein expression
3T3	Retrovirus infection	0.1-0.5	Gene transfer into animals; expression in different cell types
<i>Other cells</i>			
CHO(DHFR <sup>-</sup> )	Stable DHFR <sup>+</sup> transformant	0.01-0.05	
	Amplified MTX <sup>r</sup>	10	High-level constitutive protein expression
Primate	Vaccinia virus infection	1	Production of vaccines; expression of toxic proteins
	EBV vector	n.a.	Cloning by expression

<sup>a</sup>Abbreviations: BPV, bovine papilloma virus; EBV, Epstein-Barr virus.

expression levels obtained from SV40 recombinant viruses, retroviruses, and vaccinia viruses are shown in Table 16.12.1 in comparison to other expression strategies. A more detailed review of the different eukaryotic viral vectors can be found in Muzyczka (1989).

Most viral expression systems have certain common limitations. The first is size of the inserted sequence. If the sequence is too large, it may not be packaged properly into the viral genome (maximal insert sizes for SV40 and retroviruses are 2.5 kb and 6 kb, respectively) and/or may be subjected to rearrangement upon propagation of the viral stock. The second limitation is the cytopathic effect of some viruses on the host cell, which limits expression to a relatively short period of time. Third, the variability in gene expression depends on multiple parameters. The reasons for this are not completely clear but depend upon proper translation, processing, and modification of the resulting protein; thus, there is a large degree of

variability in the success with any particular DNA insert.

UNITS 16.15-16.19 address one viral vector system, vaccinia virus, which has demonstrated success. Vaccinia virus is most useful for the production of proteins (such as regulatory factors) that are potentially toxic to the cell.

### TRANSIENT EXPRESSION

The efficiency of expression from transient transfection depends on the number of cells that take up the transfected DNA, the gene copy number, and the expression level per gene. Most methods of DNA transfer allow 5% to 50% of the cells in the population to acquire DNA and express it transiently over a period of several days to several weeks. Eventually, however, because cells containing the foreign DNA grow more slowly, they are lost from the population. Although this gradual decrease in the amount of expression occurs, transient expression offers a convenient means to compare

expression from different vectors and to verify that any given expression plasmid is functional before initiating the more laborious procedure of isolating and characterizing stably transfected cell lines. Because they do not require isolation of clones of cells with the vector integrated at different sites, transient expression experiments are not subject to the differences such position effects can have on expression levels. In addition, transient expression experiments preclude the possibility of selecting cells that harbor mutations either in the transfected DNA or elsewhere in the host chromosome (which may influence results).

Transient DNA transfection is most frequently used to: (1) verify the identity of cloned genes based on their ability to express a particular activity, (2) rapidly study the effect of engineered mutations on either gene activity or protein function, and (3) isolate genes from cDNA libraries constructed in mammalian expression vectors based on their ability to express a particular activity in cells. The limitations of transient expression are that it is difficult to scale up for production of large quantities of protein (>1 mg), that it is difficult to study the consequences of gene expression only in the portion of the total population that has been transfected, and that the high copy number is eventually lethal; this lethality may significantly affect results.

*UNIT 16.13* describes procedures and vectors used for transient expression in COS cells. This cell line is most frequently used for transient expression and is derived from African green monkey kidney cells by transformation with an origin-defective simian virus 40 (SV40). COS cells express high levels of the SV40 large tumor (T) antigen which is required to initiate viral DNA replication at the origin of SV40. T antigen-mediated replication can amplify the copy number of plasmids containing the SV40 origin of replication to >100,000 per cell, which results in high expression levels from the transfected DNA.

### STABLE DNA TRANSFECTION

If a selection procedure is applied after DNA transfection, it is possible to isolate cells that have stably integrated the foreign DNA into their genome (see *UNIT 9.5* for an additional discussion). Different cell lines exhibit different frequencies of stable transformation and vary in their capacity to incorporate foreign DNA. In most cases, the limiting factor for obtaining stable transformants is the frequency of DNA integration, not the frequency of DNA

uptake. Cells selected for by incorporation and expression of one genetic marker will frequently incorporate a second gene provided on an independent plasmid during transfection; this ability to incorporate two separate plasmids into the chromosome has been termed cotransformation. During this process, transfected DNA molecules usually become ligated inside the cell and subsequently integrate as a unit via nonhomologous recombination into host chromosomal DNA.

Different cell lines and transfection methods yield varying frequencies of cotransformation. For example, the frequency of stable cotransformation in CHO cells is lower than that observed in mouse L cells, possibly because mouse L cells are able to incorporate more DNA into their genome than CHO cells. Cotransformation using calcium phosphate-mediated DNA transfection is very efficient, whereas cotransformation by fusion of bacterial protoplasts (containing two independent plasmids) with mammalian cells is very rare. When cotransformation is inefficient, it is desirable to engineer both the selectable marker and the gene of interest into the same plasmid. A number of vectors that facilitate this procedure have been constructed (Kaufman, 1990a).

Stable transformants are usually selected by their ability to confer resistance to cytotoxic drugs. Such resistance can be recessive or dominant. Genes conferring dominant drug resistance can be used independently of the host cell line. Frequently, selectable marker genes are derived from bacterial genes for which there is no mammalian counterpart. For example, the Tn5 neomycin phosphotransferase gene encoding resistance to the antibiotic G418, or the *Escherichia coli* hygromycin phosphotransferase gene encoding resistance to hygromycin have been engineered to be expressed and selected in mammalian cells.

Genes conferring recessive drug resistance require a particular host that is deficient in the activity being selected. Many recessive genetic selectable markers encode enzymes involved in the purine and pyrimidine biosynthetic pathways. When de novo biosynthesis for purines or pyrimidines is inhibited, cells can utilize purine or pyrimidine salvage pathways, providing the salvage enzymes (i.e., thymidine kinase, hypoxanthine-guanine phosphoribosyltransferase, adenine phosphoribosyltransferase, or adenosine kinase) necessary for the conversion of nucleoside precursors to the corresponding nucleotides are present (Fig 16.12.1). These salvage enzymes are not required for cell

growth when de novo purine or pyrimidine biosynthesis is functional; thus, cells deficient in a particular salvage pathway are viable under normal growth conditions. However, when drugs that inhibit de novo biosynthesis (such as methotrexate) are added, the cells die. Cells that acquire the capability to express the deficient activity (i.e., the missing salvage enzyme) via gene transfer can be selected for under these conditions. In a complementary manner, in cells that are defective in de novo biosynthetic pathways and have functional salvage pathways, it is possible to select for expression of the defective gene (e.g., dihydrofolate reductase or aspartate transcarbamylase) in the de novo pathway by removal of nucleosides from the growth medium.

## AMPLIFICATION OF TRANSFECTED DNA

Frequently, it is desirable to increase expression by selecting for increased copy number of the transfected DNA within the host chromosome. The ability to coamplify transfected DNA has permitted a 100- to 1000-fold increase in the expression of the proteins encoded by transfected DNA. Although there are over twenty selectable and amplifiable genes that have been described (Kaufman, 1990a), the most experience and success has occurred when methotrexate selection has been used for amplification of transfected dihydrofolate reductase genes. UNIT 16.14 describes the use of dihydrofolate reductase-deficient CHO cells to obtain high-level expression of heterologous

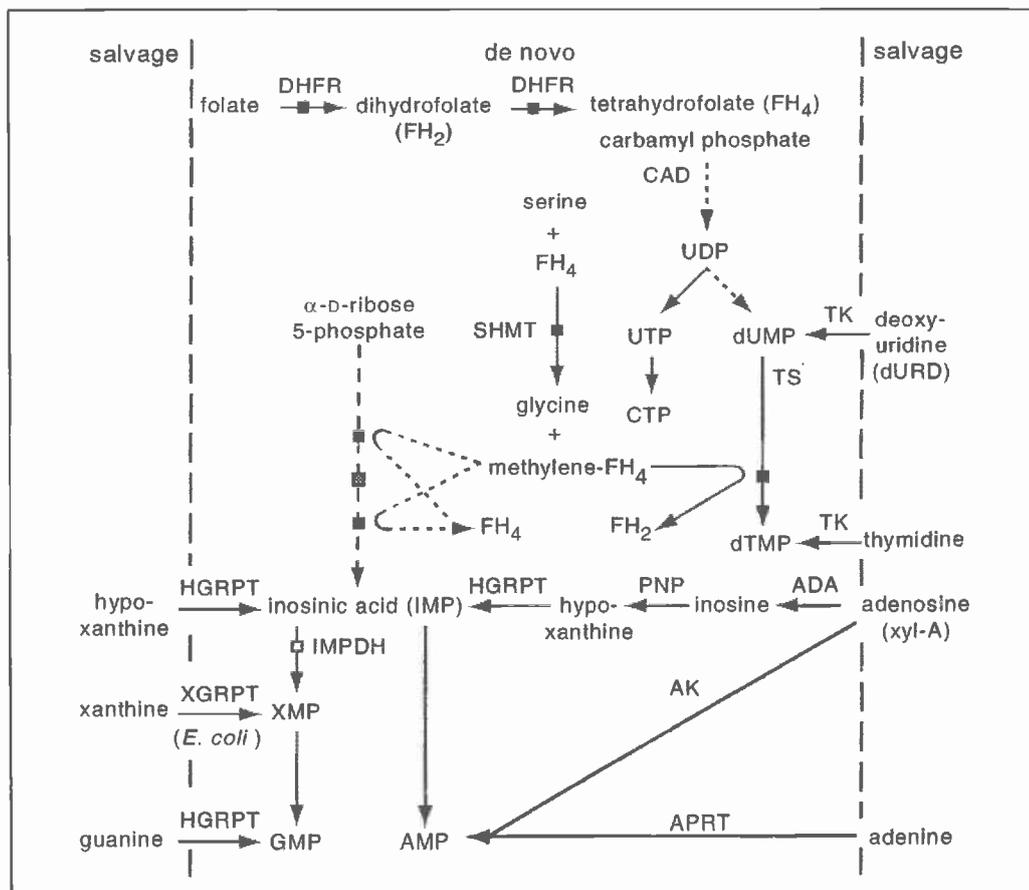

**Fig. 16.12.1** Purine and pyrimidine biosynthetic pathways. The solid arrows indicate single reactions. Dashed arrows indicate multiple reactions. Solid squares indicate reactions inhibited by methotrexate. The hatched square indicates the primary reaction inhibited by azaserine. The open square indicates the reaction inhibited by mycophenolic acid. Abbreviations used for enzymes involved in de novo biosynthetic pathways: **DHFR**, dihydrofolate reductase; **CAD**, carbamoyl-phosphate synthetase, aspartate transcarbamoylase, and dihydroorotase; **SHMT**, serine hydroxymethyl transferase; **TS**, thymidylate synthetase; **IMPDH**, inosine-monophosphate dehydrogenase. Abbreviations used for enzymes involved in salvage pathways: **TK**, thymidine kinase; **ADA**, adenosine deaminase; **PNP**, purine nucleoside kinase; **AK**, adenosine kinase; **APRT**, adenosine phosphoribosyltransferase; **HGRPT**, hypoxanthine-guanine phosphoribosyltransferase; **XGRPT**, *E. coli* xanthine-guanine phosphoribosyltransferase. Other abbreviations: **FH**, tetrahydrofolate; **xyl A**, 9- $\beta$ -D-xylofuranosyl adenine. This figure has been adapted from Kaufman (1987).

genes through coamplification by selection for methotrexate resistance.

## EXPRESSION VECTORS

Although a wide variety of expression vectors have been described over the past 5 years, it is difficult to compare results from different vectors used in different laboratories with different inserts. Most mammalian cell expression vectors are designed to accommodate cDNAs rather than large genomic fragments because the small size of cDNA clones makes them more convenient to manipulate. Today most useful vectors contain multiple elements including: (1) an SV40 origin of replication for amplification to high copy number in COS monkey cells, (2) an efficient promoter element for high-level transcription initiation, (3) mRNA processing signals such as mRNA cleavage and polyadenylation sequences, and frequently intervening sequences as well, (4) polylinkers containing multiple restriction endonucleases sites for insertion of foreign DNA, (5) selectable markers that can be used to select cells that have stably integrated the plasmid DNA, and (6) plasmid backbone sequences to permit propagation in bacterial cells.

In addition to the previously mentioned properties, most vectors also contain an inducible expression system that is regulated by an external stimulus. Sequences from a number of promoters that are required for induced transcription have been identified and engineered into expression vectors to obtain inducible expression. Several useful inducible vectors have been based on induction by  $\beta$ -interferon, heat-shock, heavy metal ions, and steroids such as glucocorticoids (Kaufman, 1990b). If the effect of an expressed protein on a particular cellular process is being studied, it is important to determine that the inducing stimulus does not interfere with that cellular process. It is also important to know the factor of induction (i.e., the difference between the basal and induced level of expressed protein) as well as the maximal achievable expression level. In many cases, the factor of induction may be large but the maximal level of expression very low compared to expression from a strong constitutive promoter.

## CHOICE OF EXPRESSION SYSTEM

In evaluating which approach to take in expressing a gene, it is most important to con-

sider the goals of the expression work. If expression is required to demonstrate that a clone has some functional activity or to characterize this activity, then transient expression in COS cells is often the most convenient approach. If a large quantity of protein (>1 mg) is required, then stable coamplification in CHO cells is generally the most desirable approach. If the gene is potentially cytotoxic, high-level expression may be approached through vaccinia virus vectors or inducible promoter-vector systems. If there is a particular requirement for the host to produce the protein properly then that requirement will dictate the choice of the host. It is unusual that proteins do require host-specific posttranslational modifications. However, if this does occur, it is usually desirable to study expression of the gene in a variety of host cells, and a retrovirus vector would be the system of choice.

## TROUBLESHOOTING

If protein expression from the heterologous gene cannot be detected, it is important to examine the vector system in detail. In this sequence, each point should be satisfactorily addressed before proceeding to the next step.

1. Confirm the expected structure of the vector using restriction mapping (*UNITS 3.1 & 3.2*) and, if necessary, DNA sequencing (*UNITS 7.4 & 7.5*).
2. Determine transfection efficiency by including a positive control—e.g., the same vector with another insert.
3. Ensure that the RNA is of the expected size and amount compared to an appropriate control by preparing RNA (*UNITS 4.1, 4.2, & 9.8*) and analyzing it by northern hybridization (*UNIT 4.9*).
4. Use a completely different expression vector or system (*UNITS 16.13-16.18*) if the RNA transcript of the correct size cannot be detected in the transfected cells, as it is always possible that some unforeseen situation may result in aberrant splicing (Wise et al., 1989).
5. Determine if the coding region may contain a point mutation or other lesion that keeps it from encoding a full-length protein by carrying out *in vitro* translation to produce protein (*UNIT 10.17*) using mRNA isolated from transfected cells and using RNA transcribed by *in vitro* transcription (i.e., SP6; *UNIT 3.8*) of a vector containing the cDNA insert.

## LITERATURE CITED

Kaufman, R.J. 1987. High level production of proteins in mammalian cells. *In Genetic Engineering: Principles and Methods* (J.K. Setlow, ed.) pp. 155-198. Plenum, New York.

Kaufman, R.J. 1990a. Selection and coamplification of heterologous genes in mammalian cells. *Methods Enzymol.* 185:537-566.

Kaufman, R.J. 1990b. Overview of vectors used for expression in mammalian cells. *Methods Enzymol.* 185:487-511.

Muzyczka, N. (ed.) 1989. *Eukaryotic Viral Expression Vectors: Current Topics in Microbiology and Immunology*. Springer-Verlag, Berlin.

Wise, R.J., Orkin, S.H., and Collins, T. 1989. Aberrant expression of platelet-derived growth factor A-chain cDNAs due to cryptic splicing of RNA transcripts in COS-1 cells. *Nucl. Acid Res.* 17:6591-6601.

---

Contributed by Randal J. Kaufman  
University of Michigan  
Ann Arbor, Michigan

# Transient Expression of Proteins Using COS Cells

UNIT 16.13

**BASIC  
PROTOCOL**

This unit describes the use of COS cells to efficiently produce a desired protein in a short period of time. These cells express high levels of the SV40 large tumor (T) antigen, which is necessary to initiate viral DNA replication at the SV40 origin. Three factors contribute to make COS cell expression systems appropriate for the high-level, short-term expression of proteins: (1) the high copy number achieved by SV40 origin-containing plasmids in COS cells 48 hr posttransfection, (2) the availability of good COS cell expression/shuttle vectors, and (3) the availability of simple methods for the efficient transfection of COS cells. Each COS cell transfected with DNA encoding a cell-surface antigen (in the appropriate vector) or cytoplasmic protein will express several thousand to several hundred thousand copies of the protein 72 hr posttransfection. If the transfected DNA encodes a secreted protein, up to 10  $\mu$ g of protein can be recovered from the supernatant of the transfected COS cells 1 week posttransfection. COS cell transient expression systems have also been used to screen cDNA libraries, to isolate cDNAs encoding cell-surface proteins, secreted proteins, and DNA binding proteins, and to test protein expression vectors rapidly prior to the preparation of stable cell lines (UNIT 9.5).

This transfection protocol is a modification of that presented in UNIT 9.2 and gives conditions for optimal transfection of COS cells (see UNIT 9.9 for additional details). The main difference between this procedure and that in UNIT 9.2 is the composition of the DEAE-dextran/chloroquine solution, which is prepared here in PBS, not TBS, and contains chloroquine to prevent the acidification of endosomes presumed to carry the DEAE-dextran/DNA into the cell. (This acidification results in acid hydrolysis of the DNA, giving rise to mutations and destruction of the DNA.) With this protocol, 40% to 70% of the cells can be routinely transfected.

## Materials

- Appropriate vector (see commentary)
- COS-7 cells to be transfected (see critical parameters; ATCC #CRL1651)
- Dulbeccos minimum essential medium with 10% calf serum (DMEM-10 CS; UNIT 9.4)
- DMEM with 10% NuSerum (Collaborative Research #55000) (DMEM-10 NS; UNIT 9.4), 37°C
- Phosphate-buffered saline (PBS; APPENDIX 2)
- DEAE-dextran/chloroquine solution: PBS containing 10 mg/ml DEAE-dextran (Sigma #D9885) + 2.5 mM chloroquine (Sigma #C6628)
- 10% dimethyl sulfoxide (DMSO; Sigma #D5879) in PBS
- 0.5 mM EDTA in PBS
- 100-mm tissue culture dishes
- Humidified 37°C, 6% CO<sub>2</sub> incubator
- Phase-contrast microscope
- Sorvall RT-6000B rotor (or equivalent)
- Additional reagents and equipment for subcloning DNA (UNIT 3.16), preparing miniprep DNA (UNIT 1.6), and purifying DNA by CsCl/ethidium bromide equilibrium centrifugation (UNITS 1.7 & 9.1)

1. Subclone the gene of interest into the appropriate vector to obtain the desired recombinant DNA. Purify the recombinant DNA by a miniprep procedure (5-ml culture) or by CsCl/ethidium bromide centrifugation.

**Protein  
Expression**

**16.13.1**

Supplement 38

Contributed by Alejandro Aruffo

*Current Protocols in Molecular Biology* (1997) 16.13.1-16.13.7

Copyright © 1997 by John Wiley & Sons, Inc.

2. Seed COS-7 cells in DMEM-10 CS at ~20% confluence per 100-mm dish the day prior to transfection (so they will be ~50% confluent the next day). Grow cells overnight in a CO<sub>2</sub> incubator (6% CO<sub>2</sub>) at 37°C to ~50% confluence.

*A confluent dish of COS-7 cells (~10<sup>6</sup> cells) is usually split 1:5 on the day prior to transfection to give 2 × 10<sup>5</sup> cells/100-mm dish in 10 ml of DMEM-10 CS.*

3. Just before use (for each 100-mm dish of COS cells to be transfected), thoroughly mix 5 ml of 37°C DMEM-10 NS with 0.2 ml of DEAE-dextran/chloroquine solution. Add 5 to 10 µg recombinant DNA and mix.

*It is important that the DEAE-dextran be well mixed with the media before adding the DNA—otherwise, the DNA, a negatively charged polymer, will form large precipitates with DEAE-dextran, a positively charged polymer. These large precipitates cannot be taken up by the cell, resulting in a reduced transfection efficiency. When larger dishes are used, the amount of medium/DEAE/DNA should be sufficient to easily cover the cells and should include 400 µg/ml DEAE-dextran, 100 µM chloroquine, and 1 to 2 µg/ml DNA in DMEM-10 NS.*

*Either CsCl-purified (UNIT 1.7) or miniprep (UNIT 1.6) plasmid DNA can be used for the transfections. If miniprep DNA is used, use 1/5 of the miniprep per transfection. DNA can also be prepared as described in the second support protocol of UNIT 9.1.*

4. Aspirate medium from COS cells and for each 100-mm dish, add DMEM-10 NS/DEAE-dextran/DNA prepared in step 3. Incubate cells 3 to 4 hr in a CO<sub>2</sub> incubator at 37°C. Observe the cells using a phase-contrast microscope.

*The DEAE-dextran will cause cells to retract and become vacuolated. Efficiency of transfection increases with longer incubation periods; on the other hand, so does cell death. The 3- to 4-hr incubation suggested here is a good starting point. However, several time points should be tried to optimize transfection of the particular population of cells used.*

5. Aspirate DMEM/DEAE-dextran/DNA and add 5 ml of 10% DMSO (prepared in PBS). Incubate cells 2 min at room temperature.

*The DMSO shock results in increased transfection efficiencies. Without this step, transfection efficiencies might be lower by a factor of two or more.*

6. Aspirate DMSO and add 10 ml DMEM-10 CS. Grow cells overnight (12 to 20 hr) in a CO<sub>2</sub> incubator at 37°C.

7. Passage (split and replat) each 100-mm dish of transfected COS cells into two new 100-mm dishes. Grow cells in a CO<sub>2</sub> incubator at 37°C as described in step 8a or 8b.

*After transfection, the COS cells will look unhealthy. Passaging them the day after transfection facilitates recovery, resulting in better levels of protein expression. In addition, DEAE-dextran treatment makes the cells sticky, and passaging the cells the morning after transfection restores their adhesion characteristics so that they may be once again lifted by a gentle treatment with PBS and EDTA (see step 8b).*

- 8a. When expressing secreted proteins, add 5 ml DMEM-10 CS 96 hr (4 days) after completing step 7 and incubate 4 days. Harvest the medium, remove dead cells and debris by centrifuging 10 min in a Sorvall RT-6000B rotor at ~2000 rpm (~1000 × g), room temperature, and save the supernatant (see anticipated results). Detect secreted proteins by metabolic labeling (UNIT 10.18) and immunoprecipitation (UNIT 10.16), immunoaffinity chromatography (UNIT 10.11), radioimmunoassay (UNIT 11.16), western blotting (UNIT 10.8), or bioassay (UNIT 9.5).

*Do not aspirate the old medium prior to addition of 5 ml DMEM-10 CS because this medium contains the secreted protein. Addition of extra medium 96 hr posttransfection results in better yield of expressed protein; however, it also increases the level of total*

protein (since the medium contains 10% serum), which could complicate protein purification. To eliminate this problem, COS cells can be placed in serum-free medium 10 to 12 hr after they have been replated although (in our hands) this results in a 10-fold lower yield of expressed protein than in the presence of serum. Thus, unless it is absolutely necessary to remove additional contaminating protein, serum should be present in the medium even at reduced levels (1% to 2%).

- 8b. When expressing cell-surface or intracellular proteins, aspirate medium from cells 72 hr (3 days) after transfection in step 6. Add 5 ml PBS, swirl, and aspirate PBS. Add 5 ml of 0.5 mM EDTA in PBS and incubate 15 min in a CO<sub>2</sub> incubator at 37°C. Lift cells from the dish by gently dislodging them with a Pasteur pipet. Stain cell-surface proteins with the appropriate fluorescent antibody and detect by microscopy or flow cytometry (Yokoyama, 1991).

*Transfected COS cells will tend to clump when lifted from the dish. Pipetting the cells up and down will tend to disrupt these clumps. More effective dispersion of the clumps can be obtained by forcing the cells through a 100- $\mu$ M nylon mesh.*

## COMMENTARY

### Background Information

#### COS cells

COS cells are African green monkey kidney cells (CV-1) that have been transformed with an origin-defective SV40 virus, which has integrated into COS cell chromosomal DNA. Therefore, COS cells produce wild-type SV40 large T antigen but no viral particles. Since SV40 large T antigen is the only viral protein required in *trans* (i.e., its coding sequence need not be located on the DNA molecule on which it acts) for viral replication, SV40 origin-containing plasmids replicate in these cells to a high copy number (10,000 to 100,000 copies/cell) 48 hr posttransfection. If the plasmid carries a cDNA or genomic insert encoding a desired protein (under the control of the appropriate promoter), COS cells will express the protein at relatively high levels over a short period of time. Transfected COS cells produce protein in a burst that starts ~24 hr posttransfection and can last for up to a week. However, due to the excessive burden placed on the transfected cell by the replicating plasmid and the high levels of protein production, the transfected cells typically either die or lose the plasmid a week after transfection.

COS cells were developed by Yakov Gluzman (1981) as a host for the propagation of SV40 virus early-region mutants. The first SV40 origin-containing plasmids to be used in conjunction with COS cells were made by Lusky and Botchan (1981). Short-term expression systems using both COS cells and SV40 origin-containing plasmids were initially used to identify DNA sequences required for tran-

scription of the human  $\alpha$ 1-globin gene (Mellon et al., 1981).

COS cells were first used to produce cell-surface and secreted proteins by Rose and Bergmann (1982), who looked at the expression of wild-type and mutant vesicular stomatitis virus glycoprotein in transfected cells. This technique was subsequently used to study the expression of insulin (Laub and Rutter, 1983), somatostatin (Warren and Shields, 1984), and acetylcholine receptors (Mishina et al., 1984). These experiments demonstrated that COS cells could be used to express biologically active cell-surface and secreted proteins. Furthermore, these proteins were correctly processed although they are normally not produced by COS cells.

COS cell expression was initially used to screen a cDNA library to isolate a cDNA encoding human granulocyte/macrophage colony-stimulating factor (Wong et al., 1985). This was subsequently extended to isolation of cDNAs encoding cell-surface proteins (Seed and Aruffo, 1987; Aruffo and Seed, 1987a) and DNA-binding proteins (Tsai et al., 1989).

The expressed protein produced in COS cells is, in most cases, biologically active. However, although COS cells are able to carry out some posttranslational modifications, they may not modify the expressed protein in exactly the same way as the cell that would normally produce it. For example, COS cells do not express the  $\alpha$ -(1,3)fucosyltransferase which is capable of transferring fucose to either sialyl or asialyl precursors (Goelz et al., 1990). In addition, insufficient posttranslational modification occurs in the case of lymphocyte cell-surface

proteins, which tend to be underglycosylated in COS cells (Aruffo and Seed, 1987b). This might be due to an overburdening of the COS cell glycosylation machinery by the high levels of protein expression and/or by the lack of enzymes required to carry out the full posttranslational modifications.

An alternative to COS cells is provided by WOP cells (Dailey and Basilico, 1985), which are mouse 3T3 cells transformed by an origin-defective polyoma virus. Like COS cells, they produce no viral particles. However, they produce polyoma large T antigen and are therefore capable of replicating a plasmid containing a polyoma origin of replication to a copy number that is typically ten times lower than that obtained in COS cells. WOP cells are also more delicate than COS cells, making them harder to transfect. For these two reasons, COS cells should be used whenever possible. However, WOP cells should be used in those cases where a monoclonal antibody which is used to identify and/or purify the protein being expressed cross-reacts with COS cell proteins. This situation has arisen when transient expression in COS cells was carried out in order to clone a human

protein with a mouse anti-human monoclonal antibody that also recognizes the equivalent monkey protein (Seed et al., 1987). In this situation, the mouse cell line presented a useful alternative to COS cells by avoiding monoclonal antibody cross-reactivity.

#### Vectors

The main requirements of any COS cell expression/shuttle vector are: (1) an SV40-derived origin of replication, (2) appropriate eukaryotic transcription regulatory elements (i.e., enhancer, promoter, and polyadenylation signal sequences), (3) a prokaryotic origin of replication, and (4) a prokaryotic genetic marker for selection in *Escherichia coli*. A particularly useful example of such a vector is CDM8 (Fig. 16.13.1; Seed, 1987). The eukaryotic transcription element of CDM8 is composed of the cytomegalovirus (CMV) enhancer-promoter, with an SV40 virus-derived intron and polyadenylation signal; the CMV promoter is a *cis* element (i.e., one that is located adjacent to the DNA it acts on) that directs transcription of the DNA subcloned downstream from it. The prokaryotic genetic

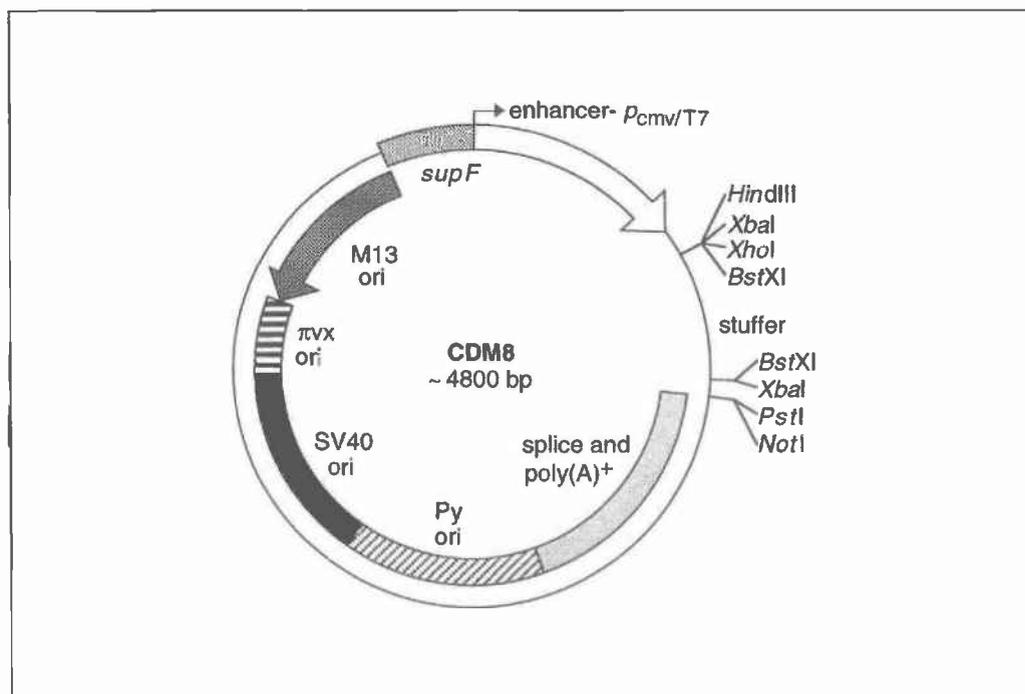

**Figure 16.13.1** CDM8. CDM8 (Seed, 1987) is a COS cell expression/shuttle vector that contains an SV40-derived origin of replication (SV40 ori), eukaryotic transcription regulatory elements [splice and poly(A)<sup>+</sup>], a prokaryotic origin of replication ( $\pi$ vx; derived from the pBR322 ori), and a prokaryotic genetic marker (*supF*). In addition, CDM8 contains an M13 origin of replication (M13 ori), a T7 RNA polymerase promoter ( $P_{CMV/T7}$ ), and a polyoma-derived origin of replication (Py ori). Any restriction endonuclease sites shown can be used for cloning, but the inserted fragment must have its 5' end nearest the enhancer  $P_{CMV/T7}$ . The stuffer sequence is used to detect a size difference after a restriction digest.

marker in CDM8 is provided by the *supF* (amber suppressor) gene. CDM8 is propagated in host bacterial cells containing helper plasmid P3, which contains amber mutations in the genes responsible for tetracycline and ampicillin resistance (*UNIT 1.4*). (P3 has been introduced into many *E. coli* strains.) When CDM8 is transformed into an *E. coli* strain containing P3 (*UNIT 1.8*), the amber mutations are suppressed, rendering the host resistant to tetracycline and ampicillin. In addition to these elements, the CDM8 expression/shuttle vector contains an M13 origin of replication so that it can be used for the production of single-stranded DNA (*UNIT 1.15*), a T7 RNA polymerase promoter for preparation of mRNA in vitro (*UNIT 3.8*), and a polyoma virus-derived origin of replication which permits plasmid replication in WOP cells.

Other vectors commonly used for COS cell transient expression include pXM (Yang et al., 1986) and pDC201 (Sims et al., 1988). These two plasmids contain the adenovirus-2 major late promoter and tripartite mRNA leader. This element acts in conjunction with the adenovirus VA RNA (also produced by the vectors) to increase the translatability of the mRNA encoding the desired protein. It is thought that adenovirus VA RNAs increase translation efficiency of mRNAs containing the major late promoter tripartite leader by facilitating the interaction between mRNA and a 43S ribosomal protein translation preinitiation complex (Kaufman, 1985).

### Critical Parameters

Efficiency of transfection depends critically on the length of time that the cells (COS or other cells) are incubated in the presence of DEAE-dextran/DNA. Longer periods of time result in higher transfection efficiencies. However, the DEAE-dextran/chloroquine solution is quite toxic to cells and in general, cells should not be in its presence for >4 hr. In the past, DEAE-dextran transfections were carried out in the absence of serum, because a precipitate of unknown composition that seemed to be very toxic formed in DEAE-dextran/calf serum mixtures. Medium containing 10% NuSerum, on the other hand, does not form this precipitate and tends to enhance the ability of the cells to tolerate DEAE-dextran; thus NuSerum should always be included in transfection medium.

Efficiency of transfection can also be affected by the quality of the DNA and the age of the DEAE-dextran/chloroquine solution. It is preferable to use CsCl-purified or other

highly purified DNA whenever possible (*UNIT 1.7*). However, miniprep DNA (*UNIT 1.6*) or DNA purified using a pZ523 column (5'→3') or by other methods can also be used. The DEAE-dextran chloroquine solution can be kept at 4°C for several months but it is wise to prepare it fresh about every 3 months.

COS cells can be obtained from the American Type Culture Collection; several sublines exist including COS-1 and COS-7. The COS-7 subline is recommended because it produces a higher plasmid copy number. These cells grow as a monolayer in DMEM-10 CS in a humidified 37°C, 5% CO<sub>2</sub> incubator; however, the ATCC grows its COS cells in DMEM-10 fetal calf serum (FCS). Since FCS is significantly more expensive than CS, changing the growth medium is worthwhile. The change from FBS to CS should be done slowly over 1 to 2 weeks.

Because the growth characteristics, transfectability, and protein expression properties of COS cells change with time and with repeated subculturing, and because these changes tend not to favor the production of high levels of proteins, it is prudent to freeze aliquots of the original COS cell stock in DMEM-10 CS/10% DMSO for later use in a -70°C freezer for 24 hr and then transfer them to a -150°C (liquid nitrogen) freezer. COS cells grow rapidly requiring passage every 4 to 5 days; typically, a confluent plate of cells is split 1 to 10.

To obtain good levels of transient protein production from transfected COS cells, it is very important to replat the transfected cells onto new dishes with fresh medium the morning after transfection. In addition to enhancing protein production, replating the transfected cells allows lifting of the cells from the dish using only PBS/EDTA (without trypsin). This is very important when transient expression by COS cells is used to produce cell-surface proteins.

### Anticipated Results

The basic protocol should yield transfection efficiencies of 40% to 70%. When COS cells are being used to produce cell-surface or intracellular proteins, it can be expected that each transfected cell will express several thousand copies of this protein (10,000 to 100,000 copies/cell) 72 hr posttransfection. If COS cells are used to produce secreted proteins, up to 1 µg/ml of protein can be recovered from the supernatant of a 100-mm dish of transfected cells 1 week posttransfection. However, the amount of protein produced by COS cells can vary dramatically depending on the protein being pro-

duced. This was the case when COS cells were used to produce soluble immunoglobulin fusion forms of cell-surface proteins (Aruffo et al., 1990). In this case, one of the fusion proteins, CD8 immunoglobulin, was secreted from COS cells at high levels (1 µg/ml) while the other, CD44 immunoglobulin, was secreted very poorly if at all. It was found that the CD44 fusion protein was sequestered inside the cell. To obtain efficient secretion of the CD44 fusion protein, it was necessary to change the amino-terminal signal sequence of the CD44 fusion protein. Interestingly, the native cell-surface forms of both CD8 and CD44 are expressed equally efficiently on the surface of transfected COS cells. For some of these immunoglobulin fusion proteins, 0.5 ml of medium contained plenty of protein (~500 ng) after concentration using a protein A-affinity matrix. In some cases, it is possible to use such COS cell supernatants directly without further purification (Aruffo et al., 1990).

### Time Considerations

It is important not to transfect the cells too soon after replating; >8 to 12 hr should pass between the time the cells are seeded on the plate and the time of transfection. Once the transfection has started, the DEAE-dextran/DNA mixture should be left on the cells for a minimum of 2 hr and a maximum of 4 hr; because the mixture increases transfection efficiency it should remain in contact with the cells as long as they appear viable. After transfection, the cells look quite unhealthy and 12 to 24 hr posttransfection, they should be replated in new dishes with fresh medium.

The peak of plasmid replication in transfected COS cells occurs 48 to 72 hr posttransfection. Protein production starts 24 hr posttransfection but peaks 72 to 96 hr posttransfection. Thus, when expressing cell-surface or cytoplasmic proteins, the cells should be harvested 72 to 96 hr posttransfection. However, transfected cells continue to produce protein for up to a week posttransfection and when expressing secreted proteins, the supernatants should be harvested a week posttransfection.

### Literature Cited

- Aruffo, A. and Seed, B. 1987a. Molecular cloning of a CD28 cDNA by a high-efficiency COS cell expression system. *Proc. Natl. Acad. Sci. U.S.A.* 84:8573-8577.
- Aruffo, A. and Seed, B. 1987b. Molecular cloning of two CD7 (T cell leukemia antigen) cDNAs by a COS cell expression system. *EMBO J.* 6:3313-3316.

- Aruffo, A., Stamenkovic, I., Melnick, M., Underhill, C.B., and Seed, B. 1990. CD44 is the principal cell-surface receptor for hyaluronate. *Cell* 61:1303-1313.
- Dailey, L. and Basilico, C.J. 1985. Sequences in the polyoma virus DNA regulatory region involved in viral DNA replication and early gene expression. *J. Virol.* 54:739-749.
- Gluzman, Y. 1981. SV-40 transformed simian cells support the replication of early SV40 mutants. *Cell* 23:175-182.
- Goelz, S.E., Hession, C., Goff, D., Griffiths, B., Tizard, R., Newman, B., Chi-Rosso, G., and Lobb, R. 1990. ELFT: A gene that directs the expression of an ELAM-1 ligand. *Cell* 63:1349-1356.
- Kaufman, R.J. 1985. Identification of the components necessary for adenovirus translational control and their utilization in cDNA expression vectors. *Proc. Natl. Acad. Sci. U.S.A.* 82:689-693.
- Laub, O. and Rutter, W.J. 1983. Expression of the human insulin gene and cDNA in a heterologous mammalian system. *J. Biol. Chem.* 258:6043-6050.
- Lusky, M. and Botchan, M. 1981. Inhibition of SV40 replication in simian cells by specific pBR322 DNA sequences. *Nature (Lond.)* 293:79-81.
- Mellon, P., Parker, V., Gluzman, Y., and Maniatis, T. 1981. Identification of DNA sequences required for transcription of the human  $\alpha$ 1-globin gene in a new SV40 host-vector system. *Cell* 27:279-288.
- Mishina, M., Kurosaki, T., Tobimatsu, T., Morimoto, Y., Noda, M., Yamamoto, T., Terao, M., Lindstrom, J., Takahashi, T., Kuno, M., and Numa, S. 1984. Expression of functional acetylcholine receptor from cloned cDNAs. *Nature (Lond.)* 307:604-608.
- Rose J.K. and Bergmann, J.E. 1982. Expression from cloned cDNA of cell-surface, secreted forms of the glycoprotein of vesicular stomatitis virus in eucaryotic cells. *Cell* 30:753-762.
- Seed, B. 1987. An LFA-3 cDNA encodes a phospholipid-linked membrane protein homologous to its receptor CD2. *Nature (Lond.)* 329:840-842.
- Seed, B. and Aruffo, A. 1987. Molecular cloning of the CD2 antigen, the T cell erythrocyte receptor, by a rapid immunoselection procedure. *Proc. Natl. Acad. Sci. U.S.A.* 84:3365-3369.
- Sims, J.E., March, C.J., Cosman, D., Widmer, M.B., MacDonald, H.R., McMahan, C.J., Grubin, C.E., Wignall, J.M., Jackson, J.L., Call, S.M., Friend, D., Alpert, A.R., Gillis, S., Urdal, D.L., and Dower, S.K. 1988. cDNA expression cloning of the IL-1 receptor, a member of the immunoglobulin superfamily. *Science* 241:585-589.
- Tsai, F., Martin, D.I.K., Zon, L.I., D'Andrea, D., Wong, G.G., and Orkin, S.H. 1989. Cloning of cDNA for the major DNA-binding protein of the erythroid lineage through expression in mam-

- malian cells. *Nature (Lond.)* 339:446-451.
- Warren, T.G. and Shields, D. 1984. Expression of preprosomatostatin in heterologous cells: Biosynthesis, posttranslational processing, and secretion of mature somatostatin. *Cell* 39:547-555.
- Wong, G.G., Witek, J.S., Temple, P.A., Wilkens, K.M., Leary, A.C., Luxenber, D.P., Jones, S.S., Brown, E.L., Kay, R.M., Orr, E.C., Shoemaker, C., Golde, D.W., Kaufman, R.J., Hewick, R.M., Wang, E.A., and Clark, S.C. 1985. Human GM-CSF: Molecular cloning of the complementary DNA and purification of the natural and recombinant proteins. *Science* 228:810-815.
- Yang, Y., Ciarletta, A.B., Temple, P.A., Chung, M.P., Kovacic, S., Witek-Giannotti, J.S., Leary, A.C., Kriz, R., Donahue, R.E., Wong, G.G., and Clark, S.C. 1986. Human IL-3 (multi-CSF): Identification by expression cloning of a novel hematopoietic growth factor related to murine IL-3. *Cell* 47:3-10.
- Yokoyama, W.M. 1991. Flow cytometry analysis using the Becton Dickinson FACScan. In *Current Protocols in Immunology* (J.E. Coligan, A.M. Kruisbeek, D.H. Margulies, E.M. Shevach, and W. Strober, eds.) pp. 5.4.1-5.4.15. Greene Publishing and Wiley-Interscience, New York.

### Key Reference

Warren and Shields. 1984. See above.

*This article shows that COS cells can be used as an efficient, short-term, mammalian expression system for the production of proteins.*

---

Contributed by Alejandro Aruffo  
Bristol-Myers Squibb  
Seattle, Washington

# Amplification Using CHO Cell Expression Vectors

UNIT 16.14

The ability to select for integration of plasmid DNA into the host chromosome allows the generation of stably transfected cell lines. With transfection of a selectable marker linked to a nonselectable target gene (or by cotransfection of the two unlinked genes), high-level expression of the desired gene is obtained by selecting for amplification of the selectable marker.

This unit presents two systems for gene amplification and expression. The first basic protocol describes the dihydrofolate reductase (DHFR) selection system while the second is based on selection of the glutamine synthetase (GS) gene. The DHFR system is probably more widely used, and results in very high levels of amplification (up to 1000 copies per cell in some cases) and expression; however, the DHFR amplification process is lengthy and may require several months to isolate and characterize a stable, amplified line. In contrast, the GS system typically requires only a single round of selection for amplification to achieve maximal expression levels. In this system the length of time necessary to isolate stably amplified clones from the primary transfectants is dramatically reduced to 2 months or less.

## AMPLIFICATION USING DIHYDROFOLATE REDUCTASE

**BASIC  
PROTOCOL**

The pED series of dicistronic vectors (Fig. 16.14.1) can be used to obtain high-level expression of a targeted gene in stably transfected cells. These vectors carry a cloning sequence for insertion of the target gene followed by the selectable and amplifiable marker gene, dihydrofolate reductase (DHFR). Alternatively, a plasmid expressing the gene of interest and a plasmid expressing DHFR can be cotransfected. DHFR-deficient CHO cells transformed with the appropriate vector(s) are selected by ability to grow in nucleoside-free medium. Subsequent selective cycling in the presence of increasing concentrations of methotrexate (MTX)—a potent inhibitor of DHFR function—results in amplification of the integrated DNA and increased expression of the desired gene product.

### Materials

pED (Kaufman et al., 1991) expressing appropriate cDNA; *or* pCVSVEII-DHFR or pAd26SV(A) (Kingston et al., 1984; Kaufman and Sharp, 1982a) and a separate vector expressing appropriate cDNA

CHO DXB11 or CHO DG44 cell lines (available from Lawrence Chasin, Columbia University) or CHO GRA (available from Randal Kaufman, Genetics Institute)

Complete ADT medium

10% glycerol

Dialyzed fetal calf serum (FCS; see reagents and solutions)

Complete  $\alpha^-$  medium ( $\alpha^-$  medium with 10% dialyzed FCS)

Sterile vacuum grease

0.05% trypsin/0.6 mM EDTA in PBS, 37°C

2% methylene blue in 50% ethanol (optional)

Methotrexate

Cloning cylinders (see reagents and solutions)

Additional reagents and equipment for subcloning (UNIT 3.16) and for  $\text{CaPO}_4$ -mediated transfection (UNIT 9.1) electroporation, (UNIT 9.3), or liposome-mediated transfection (UNIT 9.4)

**NOTE:** All incubations are performed in a humidified 37°C, 5%  $\text{CO}_2$  incubator.

**Protein  
Expression**

**16.14.1**

Supplement 18

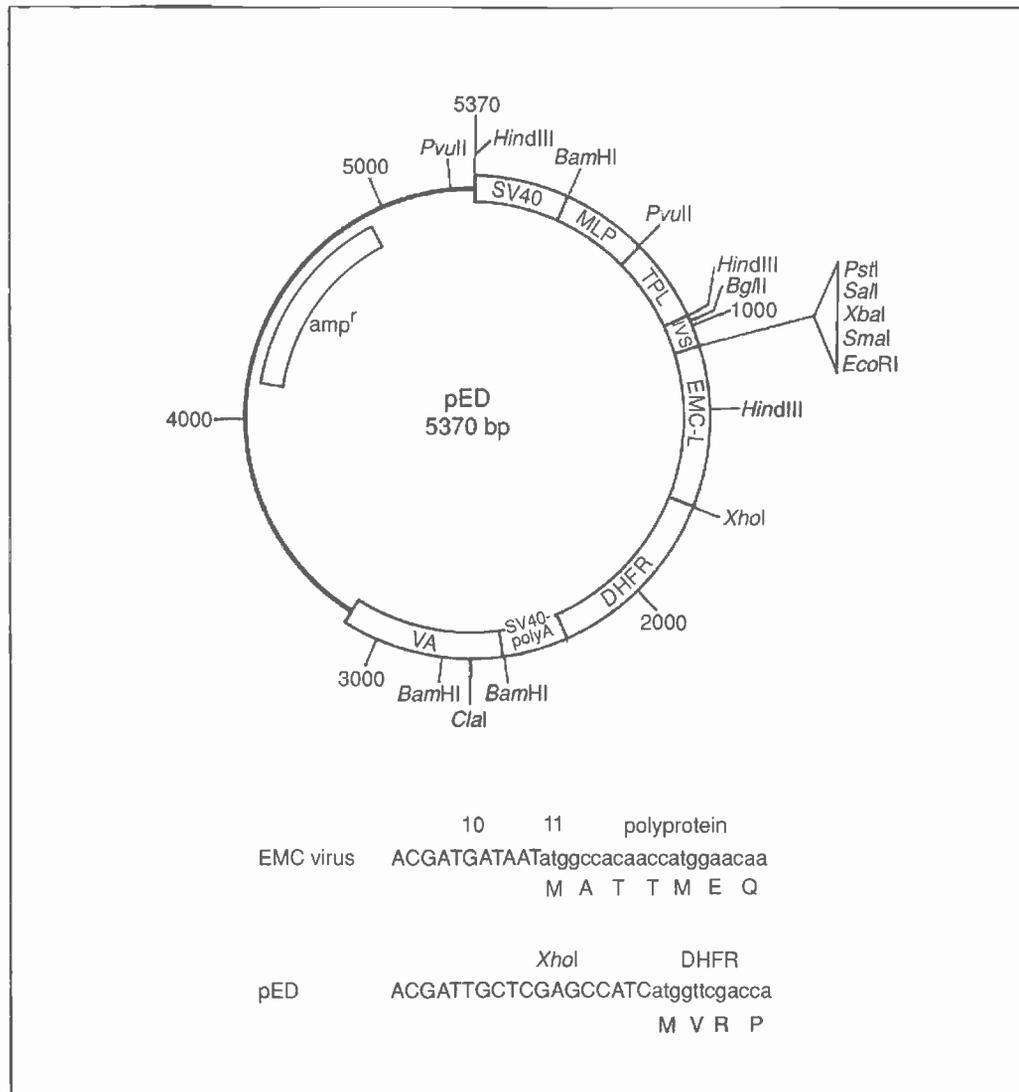

**Figure 16.14.1** Map of dicistronic mRNA expression vector pED. The components of the 5360-bp pED expression vector in the pUC18 background are indicated as follows: SV40, *Hind*III-*Pvu*II fragment containing the SV40 origin of replication and enhancer element; MLP, adenovirus major late promoter from the *Xho*I site (15.83 map units, m.u.) to the 5' cap site (16.55 m.u.); TPL, 180 bp of the first two and  $\frac{2}{3}$  of the third leaders from adenovirus major late mRNAs; IVS, a hybrid intron composed of the 5' splice site from the first leader of adenovirus major late mRNAs and a 3' splice site from an immunoglobulin gene; *Pst*I and *Eco*RI unique cloning sites; EMC-L, the 5' untranslated leader from EMC virus (nucleotides 260-827); DHFR, a murine DHFR coding region; SV40-polyA, the SV40 early polyadenylation signal; VA, the adenovirus VAI RNA gene from the *Hpa*I (28.02 m.u.) to the *Bal*I (29.62 m.u.); and  $\beta$ -lactamase, a selectable gene for propagation in *E. coli*. Below is indicated the sequence junction of the EMC-L and DHFR as compared to the context of the AUG 11 which is initiation codon for the EMC virus polyprotein. A unique *Xho*I restriction site is available for insertion of other coding regions to be translated from the EMC virus leader.

### Transfect CHO cells

1. The day before transfection, split a confluent dish of CHO cells 1:15 in complete ADT medium.
2. Transfect the cells with 5 to 10  $\mu$ g plasmid DNA (per dish) from step 1, using either electroporation (UNIT 9.3), the calcium phosphate technique (UNIT 9.1), or liposome-mediated transfection (UNIT 9.4). The calcium phosphate treatment followed by glycerol shock works well for CHO DX B11 cells. A 3-min shock with 10% glycerol should be performed 4 to 6 hr after the DNA precipitate is placed on the cells. The

gene can then be introduced into pED that also contains a DHFR gene. Alternatively, if a pED vector is unavailable, it is possible to introduce the desired gene by cotransfection using two separate plasmids. In this latter case, transfected DNA should contain the plasmid whose amplification is desired and a plasmid expressing the DHFR gene from a strong promoter [e.g., pCVSVEII-DHFR or pAdD26SV(A)]. Use a 5:1 molar ratio of the gene of interest to the DHFR gene.

*It is not necessary to physically link the DHFR gene to the gene whose amplification is desired. The two genes will integrate in the same region of the chromosome and will coamplify (Kaufman and Sharp, 1982b). Using one-fifth the molar amount of the DHFR gene makes it likely that most of the selected cell lines will contain the gene of interest in an intact form as well as the DHFR gene.*

- 3a. *For cells transfected by electroporation or calcium phosphate:* Allow the cells to reach confluence after transfection. This should occur after 2 to 3 doublings in 2 days. Split each dish 1:15 into  $\alpha^-$  medium containing 10% dialyzed FCS (complete  $\alpha^-$  medium).
- 3b. *For cells transfected using liposomes:* Add 5 ml complete  $\alpha^-$  medium and incubate overnight. Remove medium, wash twice with 37°C PBS, add 5 ml complete  $\alpha^-$  medium, and incubate 2 days. Dilute cells 1:10 or 1:15 into complete  $\alpha^-$  medium without ADT.

*Complete  $\alpha^-$  medium (containing no added nucleosides) is a selective medium, as cells need DHFR to synthesize necessary nucleosides. Use of dialyzed serum is necessary to avoid addition of nucleosides present in normal FCS. Note that methotrexate is *not* needed for selection.*

4. Incubate cells 10 to 12 days if proceeding from step 3a or 14 days if proceeding from step 3b. Move the dishes as infrequently as possible during this time to prevent formation of sibling colonies.

*Cells can float away from their original colonies, land elsewhere on the dish, and produce a colony of their own. This should be minimized, as picking and analyzing two such sibling colonies is inefficient (they presumably are identical).*

#### **Pick stable colonies**

5. Ten to fourteen days after placing the cells in selective medium, check the dishes for colonies. Colonies can be seen by holding the dish above one's head at an angle to the overhead lights and looking for opaque patches. Circle such patches with a laboratory marker so that they can easily be located and examined in the phase contrast microscope.

*In order to determine how well the transfection worked, one of the transfected dishes can be stained with methylene blue. To stain, first aspirate off the medium, then place ~2 ml of a 2% methylene blue solution (made up in 50% ethanol) on each dish. Wait 2 min, then pour the dye solution off and wash off the residual methylene blue by dipping the dish in a bucket of cold water. In order to have good success picking colonies for stable lines, each dish should have several heavily staining colonies as well as 10 more smaller colonies.*

6. Select the colonies to be picked. Circle the chosen colonies with a laboratory marker to determine where to place the cloning cylinders.

*Choose only large, healthy colonies. Colonies should have ~500 cells, and the cells should appear to be compact and polygonal. Colonies with many flat and spread-out cells should be avoided, as this morphology indicates that they are not making very much DHFR. Pick ~20 colonies so that in the end there will be many stably transfected cell lines available for amplification. Keep track of which dish a colony comes from,*

as colonies from the same dish may be siblings. This is most easily done by numbering the dishes and using that number in the name of the colony that has been picked.

It is also possible at this point to pool large numbers of transformants that have integrated the vector into different sites. Because different integration sites have quite different potentials for amplification, one can use sequential increases in MTX resistance to select cells rapidly that have amplified the gene to high copy number.

7. Coat one end of a cloning cylinder with sterile vacuum grease by touching the cylinder to grease that has been autoclaved in a glass petri dish. Gently place the cylinder around the colony to be picked (Fig. 16.14.2).

*Make certain that there is not too much grease on the end of the cloning cylinder—use a sufficient amount of grease to form a thin film between the cloning cylinder and the tissue culture dish, but do not allow the grease to cover any of the colony. The cloning cylinder is most easily positioned using bent forceps sterilized by flaming in ethanol immediately prior to use.*

8. Using a sterile Pasteur pipet, rinse the colony with 37°C trypsin/EDTA by filling and emptying the cloning cylinder (Fig. 16.14.2).

*Care must be taken to avoid knocking the cylinder over, and also to avoid scraping cells off the colony with the end of the Pasteur pipet. Hold the Pasteur pipet as close to vertical as possible in order to avoid knocking the cloning cylinder. A little trypsin can be left in the well after rinsing.*

9. Add 3 drops of 37°C trypsin/EDTA to the cloning cylinder. Wait 1 min. Fill the cloning cylinder with medium and repeatedly run the contents of the cylinder in and out through a Pasteur pipet in order to remove the trypsinized cells from the dish and disperse them. Plate the cells in a 40-mm dish.

10. As the cells grow out, split them frequently (every 4 to 5 days or so) so that they do not form large colonies. The central cells in large colonies do not fare well.

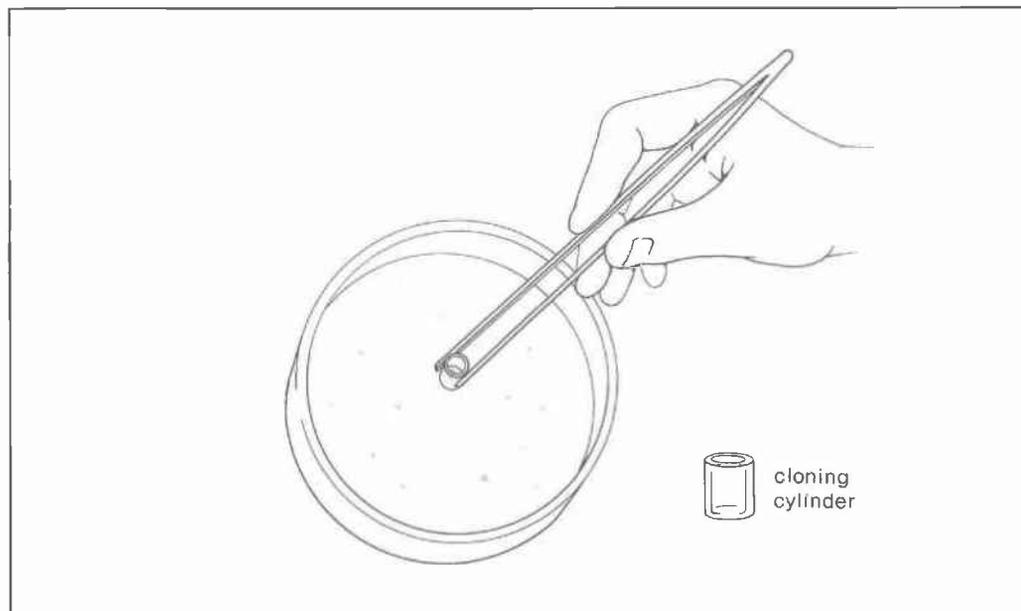

Figure 16.14.2 Placement of cloning cylinder around CHO colony.

### ***Amplify stable transfectant***

Amplification is a long process. Before amplifying a stable transfectant, one should be sure that the gene of interest has indeed been integrated into the cell in a functional form. This can be done by examining the cellular DNA by Southern analysis (UNIT 2.9), by examining the cellular RNA (Chapter 4), or most easily in many cases by using a functional assay for the introduced protein. Some cell lines amplify more readily than others (chromosome location of the introduced DNA appears to play a role), and the gene of interest can rearrange or mutate during the process. These considerations make it prudent to amplify six or more stable transfectants or pools of cells containing the gene of interest at the same time.

11. Split a confluent dish of cells growing in complete  $\alpha^-$  medium 1:6 into complete  $\alpha^-$  supplemented with 0.005  $\mu\text{M}$  methotrexate (2 dishes).

*CAUTION: Use gloves when handling methotrexate as it is carcinogenic.*

*The addition of methotrexate to the medium increases the level of selection, as methotrexate is a potent inhibitor of DHFR. Empirically, 0.005  $\mu\text{M}$  methotrexate requires ~4-fold more DHFR to be made in the cell than does complete  $\alpha^-$  medium with no methotrexate. By splitting the cells into this medium, one is selecting for cells making elevated levels of DHFR. This is generally accomplished by increasing the copy number of the transfected DHFR gene.*

12. The cells should grow to confluence fairly readily. When they do, split them 1:6 again. The cells will probably grow more slowly and take on a flat, spread-out morphology. This indicates that they are starved for DHFR.

*Cells grow well immediately after splitting into a higher level of methotrexate because they have an endogenous reserve of nucleosides that needs to be depleted before the selection takes place.*

13. Keep splitting the cells 1:6 into complete  $\alpha^-$  supplemented with 0.005  $\mu\text{M}$  methotrexate. When their rate of growth increases and when they begin to take on a more normal morphology, increase the degree of the split to 1:8, then 1:10, then 1:15. When the cells grow to confluence in 3 days from a 1:15 split and have regained a polygonal morphology, they are ready for the next amplification step.

*It is possible that cells will immediately grow well in 0.005  $\mu\text{M}$  methotrexate, indicating that they are already making enough DHFR to survive at this level of selection. If so, switch immediately to 0.02  $\mu\text{M}$  methotrexate. Many researchers start out by placing the DHFR-containing cell line in 0.005, 0.02, and 0.05  $\mu\text{M}$  methotrexate (at step 11) to see at what level the initial recombinant lines can survive.*

14. Repeat the above process (steps 12 and 13) using complete  $\alpha^-$  supplemented with 0.02  $\mu\text{M}$  methotrexate.
15. Continue amplifying by increasing the level of methotrexate in the medium by 4-fold increments. Continue until the cells are growing in 20 to 80  $\mu\text{M}$  methotrexate. The cells should now contain 500 to 2000 copies of the transfected gene.

*Be sure to freeze samples of the cells at each amplification step to avoid having to go back to the beginning in the event of contamination. Each amplification step should take 3 to 4 weeks. Use of methotrexate levels above 80  $\mu\text{M}$  does not result in much further amplification, as the ability of the cell to transport the drug becomes limiting.*



## AMPLIFICATION BY CLONING AT EACH SELECTIVE STEP

The above procedure is straightforward and does not require very much hands-on time. It does not, however, necessarily result in a clonal cell line at the end of each passage. The protocol requires a long time (9 to 12 months) to generate an amplified line. One may clone lines from the final amplified line to see whether some clones express more of a desired protein than others. Alternatively, one may amplify by cloning cells at every step and selecting for those that retain high levels of production of the protein of interest. This is a particularly attractive approach if the desired protein is secreted and easily assayed from the medium. This second approach may result in an overproducing line more rapidly, but it requires substantially more effort. If this approach is desired, substitute the following for steps 11 to 14 of the basic protocol.

- 11a. Split a confluent dish of cells growing in complete  $\alpha^-$  medium 1:15 into complete  $\alpha^-$  supplemented with 0.02  $\mu\text{M}$  methotrexate (8 dishes) and into complete  $\alpha^-$  supplemented with 0.08  $\mu\text{M}$  methotrexate (7 dishes). Feed every 4 days with the appropriate selective medium.

*The goal of this step is to find individual cells that have amplified the DHFR gene enough to grow in a significantly higher level of methotrexate. These cells will expand into colonies during the 10- to 12-day incubation. As described in step 4, sibling colonies must be avoided, so dishes should be disturbed as little as possible.*

- 12a. Check the dishes for colonies after 10 to 12 days and pick healthy colonies, as in steps 5 to 10 of the basic protocol.

- 13a. Expand the colonies and check for the level of expression of the desired product. Choose a colony that is producing good levels of the desired product, and repeat steps 11a and 12a using levels of methotrexate 16- and 64-fold higher than the level of methotrexate in which the colony is growing.

*Each of these rounds will take ~1 month, and after three to four rounds, the cells should be growing in 80  $\mu\text{M}$  methotrexate and contain highly amplified sequences.*

## AMPLIFICATION USING GLUTAMINE SYNTHETASE

In the glutamine synthetase (GS) gene amplification system, a cDNA or genomic coding sequence is inserted into the multilinker cloning site of the plasmid pEE14 (Fig. 16.14.3) such that it is expressed from the powerful hCMV promoter-enhancer. pEE14 also contains a glutamine synthetase gene that can be used as a dominant selectable marker in a variety of cell lines including CHO K1. The GS gene expressed from the plasmid confers resistance to a low level of the GS inhibitor methionine sulfoximine (MSX). CHO cells transformed with the vector are selected for lines containing increased numbers of copies of the vector using increased levels of MSX in a single round of amplification.

### Materials

Plasmid vector pEE14 (Celltech)

Complete Glasgow modified Eagle medium containing 10% dialyzed FCS (GMEM-10)

CHO K1 cell line (ATCC #CCL61)

100 mM L-methionine sulfoximine (MSX; Sigma) prepared in PBS (filter sterilize and store in aliquots at  $-20^\circ\text{C}$ ; handle carefully)

Additional reagents and equipment for subcloning (UNIT 3.16),  $\text{CaPO}_4$ -mediated transfection and glycerol shock (UNIT 9.1), and cloning by limiting dilution (UNIT 11.8)

## ALTERNATE PROTOCOL

## BASIC PROTOCOL

Protein  
Expression

16.14.7

*NOTE:* All incubations are performed in a humidified, 37°C, 5% CO<sub>2</sub> incubator.

1. Subclone the target gene into the appropriate site within the polylinker of plasmid pEE14 (Fig. 16.14.3).
2. Maintain CHO K1 cells growing exponentially in complete GMEM-10. The day before transfection, trypsinize the cells and seed several 9-cm petri dishes at 10<sup>6</sup> cells per dish.
3. Introduce 10 µg circular plasmid DNA (per dish) from step 1 into the cells using calcium phosphate-mediated transfection followed by glycerol shock. "Mock"-transfect several plates without added DNA.
4. After 24 hr, replace the medium with fresh complete GMEM-10 containing MSX at a final concentration of 25 µM (selective medium).

*CAUTION: MSX is toxic and should be handled carefully.*

5. After 4 to 5 days, refeed the plates with fresh selective medium and wait for MSX-resistant colonies to appear, typically two weeks after infection.
6. Score the number of MSX-resistant colonies on transfected and "mock"-transfected plates.

*There should be 20 to 30 colonies per plate on transfected dishes and <5 colonies per "mock"-transfected plate.*

7. Isolate several independent transfected cell lines producing significant amounts of the desired product as in steps 6 to 11 of the basic protocol for amplification using DHFR. Plate out each cell line on several petri dishes at a density of ~10<sup>6</sup> cells per dish in complete GMEM-10. Incubate 24 hr.

*Whenever trypsinizing GS-selected cells, leave the cells for 24 hr to recover before reapplying MSX. In our experience, independent transfectants amplify more efficiently than pools of transfectants.*

8. Replace the medium with fresh selective medium containing various concentrations of MSX, ranging between 100 µM and 1 mM.
9. Incubate the dishes 10 to 14 days, changing the medium once during this time.

*After this time considerable cell death should have occurred and colonies resistant to the higher levels of MSX should have appeared. The maximum concentration of MSX at which colonies survive will depend on the particular initial transfectant, but is typically between 250 µM and 500 µM.*

10. Isolate the colonies at the highest MSX concentration yielding several discrete colonies. The colonies can either be picked and assayed individually or all colonies from one initial cell line can be pooled and assayed together.

*The increased production rate can be up to 10-fold in this first round of amplification. It is not normally appropriate to select for subsequent rounds of amplification because the production rate does not usually increase significantly at higher levels of MSX.*

11. Clone the amplified cells with high production rates by limiting-dilution cloning.

## REAGENTS AND SOLUTIONS

### *Cloning cylinders*

Glass or metal cloning cylinders can be purchased (e.g., stainless steel Penicylinders, Fisher #07-9075). Place clean cylinders well rinsed in distilled water in 95% ethanol. Sterilize by flaming immediately prior to use. Alternatively, disposable cloning cylinders can be prepared by cutting off the fat end of a 200- $\mu$ l pipettor tip ~1 cm from the large end with a razor blade. Sterilize by autoclaving.

### *Complete ADT medium*

$\alpha^-$  medium (GIBCO/BRL #320-2561) supplemented with:

- 10  $\mu$ g/ml adenosine (Sigma)
- 10  $\mu$ g/ml deoxyadenosine (Sigma)
- 10  $\mu$ g/ml thymidine (Sigma)
- 10% FCS

*It is convenient to prepare stocks of the nucleosides for addition to the medium. Adenosine (1 mg/ml), deoxyadenosine (1 mg/ml), and thymidine (4 mg/ml) stocks are prepared using distilled water, and are filter sterilized.*

### *Complete GMEM-10*

*Add the following in order given, using aseptic technique:*

- 500 ml Glasgow modified Eagle medium (GMEM) without tryptose phosphate broth (GIBCO/BRL #32-1710 but made *without* glutamine; must be made to order as it is not a stock item)
- 5 ml 100 $\times$  nonessential amino acids (GIBCO/BRL #32-1140)
- 5 ml G+A (see below)
- 5 ml 100 mM sodium pyruvate (GIBCO/BRL #320-1360)
- 10 ml 50 $\times$  nucleoside mix (see below)
- 50 ml *dialyzed* FCS (see below)
- 5 ml 5000 U/ml of penicillin/streptomycin (GIBCO/BRL #600-5070)

*It is essential to use dialyzed FCS when performing GS selection because serum contains significant amounts of glutamine.*

### *Dialyzed fetal calf serum (FCS)*

Purchase from commercial supplier (e.g., GIBCO/BRL #014-06400 or J.R.H. Biosciences #12-10377) or prepare as follows:

1. Heat inactivate FCS at 56°C for 60 min.
2. Soak Spectrapor dialysis tubing (MWCO 6000 to 8000) in PBS (*APPENDIX 2*). Remove, rinse tubing, clip one end closed, and fill with FCS.
3. Dialyze 6 to 8 hr in cold room against PBS. Change dialysis solution at least once.
4. Filter sterilize using a 0.02-mm filter and store frozen (–20°C) in 50-ml aliquots.

### *Glutamate + asparagine (G+ A)*

- 600 mg L-glutamic acid (Sigma)
  - 600 mg L-asparagine (Sigma)
  - H<sub>2</sub>O to 100 ml
- Filter sterilize using a 2- $\mu$ m filter and store at 4°C

### **Methotrexate**

Dissolve methotrexate to 5 mM in  $\alpha^-$  medium and filter sterilize. Store at  $-20^\circ\text{C}$  in a foil-wrapped container.

*It is important to make a large 5 mM stock solution before starting amplification, then dilute that stock solution in  $\alpha^-$  medium for the various levels of selective media. The potency of methotrexate can vary somewhat from lot to lot, making it desirable to use one stock throughout the amplification process.*

**CAUTION:** *Methotrexate is a carcinogen and should be handled only with gloves and in a fume hood.*

### **50 $\times$ nucleoside mix**

35 mg adenosine (Sigma)

35 mg guanosine (Sigma)

35 mg cytidine (Sigma)

35 mg uridine (Sigma)

35 mg thymidine (Sigma)

H<sub>2</sub>O to 100 ml

Filter sterilize and store at  $-20^\circ\text{C}$  in 10-ml aliquots

## **COMMENTARY**

### **Background Information**

**Gene amplification.** When mammalian cells are placed in an environment that requires an increase in a normally constitutive gene product, cells that survive in many cases do so because of an increase in copy number of the gene. This process has been termed gene amplification and involves large regions of the chromosome, so that not only the selected gene becomes amplified, but the surrounding regions as well. Amplification was first detected when cells were treated with increasing concentrations of methotrexate, and the copy number of the resident DHFR gene was analyzed in the surviving cells (Alt et al., 1978). This observation, combined with the observation that cotransfected segments of DNA tend to integrate in the same chromosomal location (Wigler et al., 1978), has resulted in the ability to amplify any desired gene. Notable among the many reports of amplified genes in mammalian cells are *E. coli* XGPRT (Ringold et al., 1981), hepatitis B surface antigen (Christman et al., 1982), mouse *c-myc* (Wurm et al., 1986), tissue inhibitor of metalloproteinases using glutamine synthetase (GS) selection (Cockett et al., 1990), CD4 T lymphocyte glycoprotein (Davis et al., 1990), and human initiation factor 2 $\alpha$  using DHFR selection (eIF-2 $\alpha$ ; Kaufman et al., 1991).

Until recently, gene amplification was achieved by cotransfection of a vector carrying a selectable marker gene with another

vector carrying the nonselectable gene of interest. In this process called cotransformation, separate DNA molecules become ligated and cointegrate as a unit by nonhomologous recombination into the host chromosome (Wigler et al., 1978). Amplification of the region of DNA containing the selectable gene and the target gene is accomplished by incubating the cells in increasing amounts of a specific inhibitory drug. However, varying DNA transfection methods and cell lines can yield dramatically different frequencies of cotransformation with different plasmids. Consequently, new (since 1990) expression vectors have been developed that contain both the selectable gene and a transcription unit for the inserted target gene linked on the same plasmid. Various approaches in constructing these plasmids have been used to ensure adequate expression of both the selectable and nonselectable marker.

**CHO cells.** Many amplifiable selection markers are now available for use in mammalian cells (see Table 16.14.1; Kaufman, 1989, 1990). Although various cell lines (including monkey COS-1 and NIH 3T3) can be used for gene amplification, many protocols rely upon the use of Chinese hamster ovary (CHO) cells. The advantages of CHO cells for heterologous gene expression are (1) amplified genes that are integrated into host chromosome may be stably maintained, even in the absence of continued drug selection; (2) a variety of proteins have been expressed at

high levels (Ringold et al., 1981; Cockett et al., 1990; Davis et al., 1990; Kaufman et al., 1991); and (3) volumes of CHO cells have been scaled up to >5000 liters. Two of the most successful strategies employing CHO cells—the dihydrofolate reductase (DHFR) and glutamine synthetase (GS) gene amplification systems—are described below.

**Amplification using dihydrofolate reductase vectors.** DHFR catalyzes the conversion of folate to tetrahydrofolate, which is required for purine, amino acid, and nucleoside biosynthesis. The folic acid analogue methotrexate (MTX) binds and inhibits DHFR, causing cell death. Surviving populations of cells exposed to sequentially increasing concentrations of MTX contain increased levels of DHFR that result from gene amplification. The pED (DHFR) vector produces a transcript containing the target gene in the 5' position and the selectable marker in the 3' position of the transcript. This vector has been optimized for translation of the selectable gene in the 3' position by use of specific sequences from the encephalomyocarditis (EMC) virus that promote internal ribosome binding and translation initiation (Kaufman et al., 1991). The development of CHO cell lines (e.g., CHO DG44) that are deleted for the endogenous DHFR genes greatly increases the ease of amplification using DHFR (Urlaub and Chasin, 1980; Urlaub et al., 1983). Amplification of exogenous genes has been accomplished either by using cells and vectors that express a normal DHFR gene (Ringold et al., 1981; Kaufman and Sharp, 1982a; Kaufman

et al., 1991), or by using vectors that encode a DHFR gene partially resistant to methotrexate and normal CHO cells (Christman et al., 1982; Kaufman et al., 1991).

**Amplification using glutamine synthetase vectors.** GS provides the only pathway for synthesis of glutamine in mammalian cells (using glutamate and ammonia as substrates); thus, in a glutamine-free medium, GS is an essential enzyme. CHO cells contain endogenous GS enzyme, but concentrations of methionine sulfoximine (MSX) in excess of 20 to 25  $\mu$ M are sufficient not only to inhibit wild-type levels of GS but also to prevent the growth of the majority of natural variants that arise by amplification of the endogenous GS genes. Hence, essentially all nontransfected cells are killed when grown in media containing MSX at these levels. The GS vector pEE14 carries both the selectable GS marker and the nonselectable target gene, each transcribed from a separate promoter. The target gene is cloned into the multilinker cloning site with transcription initiating from the powerful human cytomegalovirus (hCMV-MIE) promoter-enhancer sequence, while transcription of the GS gene is driven from an SV40 late promoter (Cockett et al., 1989). The GS "minigene" in pEE14 permits sufficient GS expression to allow transformants to survive at low levels of MSX, and increased levels of MSX select cells that have undergone amplification of vector sequences integrated into the cell genome. The appropriate choice of MSX concentration for initial selection together with the use of a weakly expressed GS gene

**Table 16.14.1** Amplifiable Markers for Mammalian Cells

Selection	Gene
Adenosine, alanosine, and 2'-deoxycoformycin	Adenosine deaminase
Adenine, azaserine, and cofomycin	Adenylate deaminase
$\beta$ -aspartyl hydroxamate or albizzin	Asparagine synthetase
PALA	Aspartate transcarbamoylase
Methotrexate	Dihydrofolate reductase
Methionine sulfoximine	Glutamine synthetase
Cadmium	Metallothionein
$\alpha$ -difluoromethylornithine	Ornithine decarboxylase
Multiple drugs	P-glycoprotein 170
6-azauridine or pyrazofuran	UMP synthetase
Mycophenolic acid	Xanthine-guanine phosphoribosyltransferase

typically selects cell lines containing multiple copies of the vector. The combination of the hCMV promoter to drive the gene of interest and the GS-selection system usually provides relatively high levels of expression after only a single round of selection following gene amplification.

### Critical Parameters

For this approach to be successful, the gene of interest must be integrated in a functional form in the original cell line. It is also crucial that the gene of interest not rearrange during amplification. These two criteria may be difficult to achieve if the expressed gene is cytotoxic when overproduced. This problem can be circumvented by expressing the gene of interest from an inducible promoter and thus amplifying the gene in an "off" state (Wurm et al., 1986).

The key to obtaining high-level expression in primary transfectants is to screen as many as possible (typically ~100 lines) since the site of integration of the vector in the host cell genome has a profound influence on expression levels. To get good results on amplification, it is also important to screen a number of lines (e.g., 5 to 10 high producers), as again the integration site influences the frequency of amplification. Once high-producing lines have been isolated, it is often useful to reclone these to ensure a homogeneous population of cells, in order to increase the likelihood that the productivity will be maintained over long periods of culture. The selective agent should be present throughout these procedures and only when frozen stocks of re-cloned amplified cells have been secured may selection be relaxed if it is important to choose lines that are stable without selective agent. Finally, it may again be necessary to screen a number of lines to identify ones that are stable without selective agent.

### Anticipated Results

*Dihydrofolate reductase.* Cell lines containing >100 copies of an exogenous gene can be produced. The levels of mRNA and protein obtained depend upon the target gene to be expressed, but can constitute up to 5% of total protein synthesis (Kaufman, 1991).

*Glutamine synthetase.* Introduction of pEE14-based vectors using the CaPO<sub>4</sub>-mediated transfection usually leads to multiple copies of the vector becoming integrated in the genome (up to 200 copies). The copy

number can increase up to 30-fold in one round of selection for amplification (Cockett et al., 1989). The amount of product made depends both on the individual transfectant and on the protein being expressed, but can be up to 10 µg protein/10<sup>6</sup> cells per 24-hr period from primary transfectants for some proteins. On amplification, protein expression can parallel the increase in copy number but is likely to reach a plateau, usually after a single round of amplification for many secreted proteins, probably because the secretion apparatus is saturated. Final yields of secreted proteins from overgrown cultures have been 180 mg/liter for tissue inhibitor of metalloproteinases (TIMP), and up to 120 mg/liter for secreted variants of the rat CD4 protein (Davis et al., 1990). pEE14 has also been used successfully to express an integral membrane protein (Harfst et al., 1992).

### Time Considerations

*DHFR.* Transfection and detection of stably transformed colonies takes 2 weeks. It will take ~2 additional weeks to expand the colonies and analyze them to ensure that they contain the gene of interest. Amplification of the resultant stable lines may take up to 6 months by the standard protocol. If cells are cloned at every step, as described in the alternate protocol, the amplification process can take as little as 3 months.

*GS.* Transfection and analysis of initial cell lines takes ~4 weeks (as for DHFR selection). Selection for vector amplification and screening of resultant cell lines typically takes an additional 4 to 6 weeks; there is usually no advantage in undergoing further rounds of selection.

### Literature Cited

- Alt, F.W., Kellems, R.E., Bertino, J.R., and Schimke, R.T. 1978. Selective multiplication of dihydrofolate reductase genes in methotrexate-resistant variants of cultured mammalian cells. *J. Biol. Chem.* 253:1357-1370.
- Bebbington, C.R. and Hentschel, C.C.G. 1987. The use of vectors based on gene amplification for the expression of cloned genes in mammalian cells. *In DNA Cloning, Volume III* (D. Glover, ed.). Academic Press, San Diego.
- Christman, J.K., Gerber, M., Price, P.M., Flordellis, C., Edelman, J. and Acs, G. 1982. Amplification of expression of hepatitis B surface antigen in 3T3 cells cotransfected with a dominant-acting gene and cloned viral DNA. *Proc. Natl. Acad. Sci. U.S.A.* 79:1815-1819.

pp. 16-18  
See 09-2-11 '08

- Cockett, M.I., Bebbington, C.R., and Yarranton, G.T. 1990. High-level expression of tissue inhibitor of metalloproteinases in Chinese hamster ovary cells using glutamine synthetase gene amplification. *Bio/Technology* 8:662-667.
- Davis, S.J., Ward, H.A., Puklavec, M., Willis, A.C., Williams, A.F., and Barclay, A.N. 1990. High-level expression in Chinese hamster ovary cells of soluble forms of CD4 T lymphocyte glycoprotein including glycosylation variants. *J. Biol. Chem.* 265:10410-10418.
- Harfst, E., Johnstone, A.P., Gout, I., Taylor, A.H., Waterfield, M.D., and Nussey, S.S. 1992. The use of amplifiable high-expression vector pEE14 to study the interactions of autoantibodies with recombinant human thyro trophin receptor. *Mol. Cell Endocrinol.* 83:117-123.
- Hayward, B.E., Hussain, A., Wilson, R.H., Lyons, A., Woodcock, V., McIntosh, B., and Harris, T.J.R. 1986. The cloning and nucleotide sequence of cDNA for an amplified glutamine synthetase gene from the Chinese hamster. *Nucl. Acids Res.* 14:999-1008.
- Kaufman, R.J. 1989. Selection and coamplification. *Meth. Enzymol.* 185:537-566.
- Kaufman, R.J. 1990. Strategies for expressing high-level expression in mammalian cells. *Technique* 2:221-236.
- Kaufman, R.J. and Sharp, P.A. 1982a. Amplification and expression of sequences cotransfected with a modular dihydrofolate reductase complementary DNA gene. *J. Mol. Biol.* 159:601-621.
- Kaufman, R.J. and Sharp, P.A. 1982b. Construction of a modular dihydrofolate reductase cDNA gene: Analysis of signals utilized for efficient expression. *Mol. Cell. Biol.* 2:1304-1319.
- Kaufman, R., Davies, M., Wasley, L., and Michnik, D. 1991. Improved vectors for stable expression of foreign genes in mammalian cells by use of internal ribosomal entry site from EMC virus. *Nucl. Acids Res.* 19:4485-4490.
- Kingston, R.E., Kaufman, R.J., and Sharp, P.A. 1984. Regulation of transcription of the adenovirus E1a promoter by E1a gene products: Absence of sequence specificity. *Mol. Cell. Biol.* 4:1970-1977.
- Ringold, G., Dieckman, B., and Lee, F. 1981. Coexpression and amplification of dihydrofolate reductase cDNA and the *Escherichia coli* XGPRT gene in Chinese hamster ovary cells. *J. Mol. Appl. Genet.* 1:165-175.
- Sanders, P.G. and Wilson R.H. 1984. Amplification and cloning of the Chinese hamster glutamine synthetase gene. *EMBO J.* 3:65-71.
- Stephens, P.E. and Cockett, M.I. 1989. The construction of a highly efficient and versatile set of mammalian expression vectors. *Nucl. Acids Res.* 17:7110.
- Urlaub, G. and Chasin, L.A. 1980. Isolation of Chinese hamster cell mutants deficient in dihydrofolate reductase activity. *Proc. Natl. Acad. Sci. U.S.A.* 77:4216-4220.
- Urlaub, G., Kas, E., Carothers, A.M., and Chasin, L.A. 1983. Deletion of the diploid dihydrofolate locus from cultured mammalian cells. *Cell* 33:405-412.
- Wigler, M., Silverstein, S., Lee, L., Pellicer, A., Cheng, Y., and Axel, R. 1977. Transfer of purified herpes virus thymidine kinase gene to cultured mouse cells. *Cell* 11:223-232.
- Wurm, F.W., Gwinn, K.A., and Kingston, R.E. 1986. Inducible overproduction of the mouse *c-myc* gene in mammalian cells. *Proc. Natl. Acad. Sci. U.S.A.* 83:5414-5418.

### Key References

- Kaufman et al., 1991. See above.  
*Describes the construction and application of dicistronic DHFR vectors that allow stable, high-level expression of inserted cDNAs by selection for methotrexate resistance in both DHFR-containing and DHFR-deficient cells.*
- Cockett et al., 1990. See above.  
*Describes the construction of vectors that provide for high-level expression using the GS gene-amplification system.*

---

Contributed by Robert E. Kingston  
 Massachusetts General Hospital  
 and Harvard Medical School  
 Boston, Massachusetts

Randal J. Kaufman (DHFR)  
 Genetics Institute  
 Cambridge, Massachusetts

C. R. Bebbington and M. R. Rolfe (GS)  
 Celltech Ltd.  
 Slough, United Kingdom



# EXPRESSION OF PROTEINS IN MAMMALIAN CELLS USING VACCINIA VIRAL VECTORS

## Overview of the Vaccinia Virus Expression System

Vaccinia virus was introduced in 1982 as a vector for transient expression of genes in mammalian cells (Panicali and Paoletti, 1982; Mackett et al., 1982). This expression system differs from others in that transcription occurs in the cytoplasm of the cell rather than in the nucleus. As a vector, vaccinia virus has a number of useful characteristics, including a capacity that permits cloning large fragments of foreign DNA (>20 kbp), retention of infectivity after insertion of foreign DNA, a wide host range, a relatively high level of protein synthesis, and "appropriate" transport, secretion, processing, and posttranslational modifications as dictated by the primary structure of the expressed protein and the cell type used. For example, *N*- and *O*-glycosylation, phosphorylation, myristylation, and cleavage, as well as assembly of expressed proteins, occur in an apparently faithful manner.

Laboratory applications of vaccinia virus vectors include production of biologically active proteins in tissue culture, analysis of mutant forms of proteins, and determination of transport and processing signals. In addition, recombinant vaccinia viruses have been important for immunological studies (Benink and Yewdell, 1990). Infected cells can serve as targets to analyze the antigenic specificity of cytotoxic T cells. Recombinant viruses can also be used to infect animals in order to determine cell-mediated and humoral responses to specific proteins.

Several variations of the vaccinia vector system have been developed. Most commonly, after obtaining the virus stock (UNIT 16.16), the gene of interest is placed under control of a vaccinia virus promoter and integrated into the genome of vaccinia so as to retain infectivity (UNIT 16.17). Alternatively, expression can be achieved by transfecting a plasmid containing the vaccinia promoter-controlled gene into a cell that has been infected with wild-type vaccinia. These recombinant viruses are then characterized using various methods (UNIT 16.18). In still another variation, the bacteriophage T7 RNA polymerase gene can be integrated into the genome of vaccinia so that a gene controlled by a T7 promoter, either

in a transfected plasmid or a recombinant vaccinia virus, will be expressed.

### VACCINIA REPLICATION CYCLE

Vaccinia is the prototypal member of the Orthopoxvirus genus of the *Poxviridae* family. Poxviruses differ from other eukaryotic DNA viruses in that they replicate in the cytoplasm rather than in the nucleus. Vaccinia virus has a linear, double-stranded DNA genome of nearly 200,000 bp that encodes most or all proteins needed for replication and transcription in the cytoplasm.

The replication cycle of poxviruses is represented in Figure 16.15.1. The virus particle or virion consists of a complex core structure surrounded by a lipoprotein envelope. Remarkably, all proteins necessary for transcription of the early class of genes are packaged with the genome in the core. These include a multisubunit, DNA-dependent RNA polymerase, an early transcription factor, capping and methylating enzymes, and a poly(A) polymerase. The transcription system is activated upon infection and early mRNAs and proteins can be detected within the first hour. The early mRNAs closely resemble their eukaryotic counterparts—they are capped, methylated, polyadenylated, and of discrete size. Termination of transcription occurs ~50 bases after the sequence TTTTNT (where N can be any nucleotide; the termination signal is actually recognized as UUUUUNU in the nascent RNA). There is no evidence for splicing or other kinds of processing involving RNA cleavage.

DNA replication begins within a few hours postinfection and leads successively to the intermediate and late phases of gene expression. Early, intermediate, and late genes have different promoter sequences and utilize different transcription factors. The early transcription factor is itself a product of late genes, and the late gene transactivators are intermediate gene products. Although not yet characterized, the factors needed for intermediate gene transcription appear to be early gene products.

The mRNAs transcribed from late genes

differ from typical early mRNAs as follows. First, the termination signal UUUUUNU is not recognized at the late phase; consequently the mRNAs are long and heterogeneous in length, making procedures like northern blotting virtually useless. Second, the 5' ends of late mRNAs contain a capped poly(A) leader of ~35 nucleotides that is probably the result of an RNA polymerase slippage mechanism within the conserved TAAAT at the initiation site. The mRNAs transcribed from intermediate genes have not yet been well characterized.

Many early proteins are not synthesized later than ~6 hr postinfection (unless an inhibitor of DNA replication such as cytosine arabinoside is added) because of the cessation of early gene transcription and the relatively short half-life of all mRNAs at late times. Some genes, however, have tandem early and late promoters so that they are expressed throughout the growth cycle. Either because of intrinsic promoter strength, DNA copy number, or a prolonged period of expression (>20 hr), much more protein is made from the strongest late promoters than from the strong-

est early promoters. The relative strength and duration of expression of intermediate gene promoters have not been fully analyzed.

## EFFECTS OF VACCINIA INFECTION

Vaccinia virus can productively infect most mammalian and avian cell lines, with a few exceptions such as Chinese hamster ovary (CHO) cells. Infection generally results in rapid inhibition of host nucleic acid and protein synthesis. Inhibition of host protein synthesis is dramatic and probably results from several factors whose identities are unknown; the relative contribution of each factor may depend on the virus multiplicity, cell type, and time of analysis. At the time of maximal late gene expression, host protein synthesis has been largely suppressed, facilitating the identification of viral or recombinant proteins by pulse-labeling with radioactive amino acids.

In fibroblasts, the initial cytopathic effect—which is obvious by several hours postinfection—is cell rounding. Nevertheless, the majority of cells remain intact for ≥48 hr.

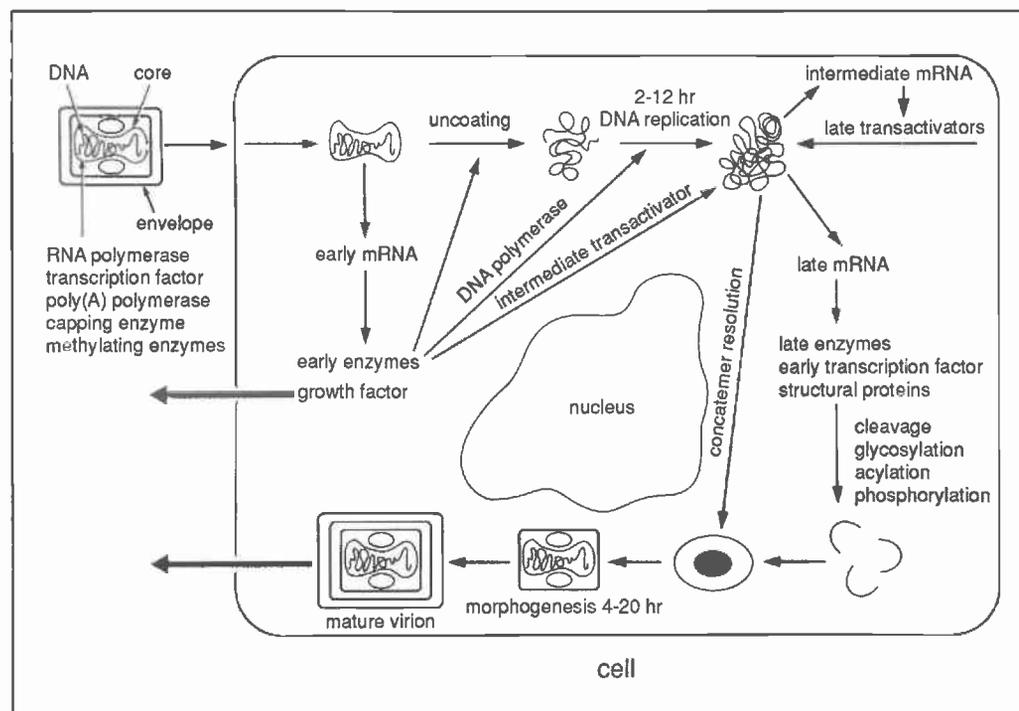

**Figure 16.15.1** Replication cycle of vaccinia virus. After entry of vaccinia virus into the cells, early genes are expressed, leading to secretion of several proteins (including a growth factor), uncoating of the virus core, synthesis of DNA polymerase (and other replication proteins), RNA polymerase subunits, and transcriptional transactivators of the intermediate class of genes. After DNA replication, intermediate mRNAs are made, some of which encode late transcriptional transactivators, leading to expression of late genes. The latter encode structural proteins, enzymes, and early transcription factors which are packaged in the assembling virus particles. Some of the mature virions are wrapped in Golgi-derived membranes and are released from the cell. The bold arrows indicate the products that exit the cell. Reprinted with permission from Raven Press.

Useful mutant strains of vaccinia virus that express proteins well but do not cause cytopathic effects or inhibit host gene expression have not been identified. Approximately 100 to 200 plaque-forming units (pfu), equivalent to ~2500 to 5000 particles, are made per cell within a 20- to 40-hr period. With the commonly used vaccinia virus WR strain, >95% of the infectious virus remains cell-associated. With some other vaccinia virus strains, notably IHD-J, larger amounts of extracellular virus are produced.

## VACCINIA VECTOR EXPRESSION SYSTEM

Genes or cDNAs containing open reading frames derived from prokaryotic, eukaryotic, or viral sources have been expressed using vaccinia virus vectors. The gene of interest is usually placed next to a vaccinia promoter and this expression cassette is then inserted into the virus genome by homologous recombination (UNIT 16.17). Use of poxvirus promoters is essential because cellular and other viral promoters are not recognized by the vaccinia transcriptional apparatus. Strong late promoters are preferable when high levels of expression are desired.

An early or compound early/late promoter, however, may be of use if it is desirable to express proteins prior to the occurrence of major cytopathic effects, or when the purpose is to make cells that express antigens in association with major histocompatibility class I molecules so they form cytotoxic T cell targets or prime animals for a cytotoxic T cell response. (The ability of vaccinia viral vectors to direct this type of antigen presentation seems to diminish late in infection.) Transcripts originating early will terminate after the sequence TTTTNT; thus, any cryptic TTTTNT termination motifs within the coding sequence of the gene should be altered by mutagenesis if an early poxvirus promoter is used (Earl et al., 1990). To mimic vaccinia virus mRNAs, untranslated leader and 3'-terminal sequences are usually kept short.

A number of plasmids have been designed with restriction endonuclease sites for insertion of foreign genes downstream of vaccinia promoters (UNIT 16.17). The expression cassette is flanked by vaccinia DNA to permit homologous recombination when the plasmid is transfected into cells that have previously been infected with wild-type vaccinia virus. The flanking vaccinia virus DNA is chosen so

that recombination will not interrupt an essential viral gene.

Without selection, the ratio of recombinant to parental vaccinia virus is usually ~1:1000. Although this frequency is high enough to permit the use of plaque hybridization (UNITS 6.3 & 6.4) or immunoscreening (UNIT 6.7) to pick recombinant viruses, a variety of methods to facilitate recombinant-virus identification have been employed. Three widely used selection or screening techniques are described in UNIT 16.17. Most commonly, the expression cassette is flanked by segments of the vaccinia thymidine kinase (TK) gene so that recombination results in inactivation of TK. Virus with a TK<sup>-</sup> phenotype can then be distinguished from those with a TK<sup>+</sup> phenotype by infecting a TK<sup>-</sup> cell line in the presence of 5-bromodeoxyuridine (5-BrdU), which must be phosphorylated by TK to be lethally incorporated into the virus genome. Alternatively, recombinant viruses can be selected by the co-expression of a bacterial antibiotic resistance gene such as guanine phosphoribosyltransferase (*gpt*). Finally, co-expression of the *Escherichia coli lacZ* gene allows color screening of recombinant virus plaques with Xgal (UNIT 16.17).

## STEPS FOR EXPRESSION OF GENES USING VACCINIA VECTORS

The expression of genes using the vaccinia expression system is presented in detail in UNITS 16.16-16.18 and outlined in the flowchart in Figure 16.15.2. A brief overview is presented below.

1. Prepare a stock of wild-type or bacteriophage T7 RNA polymerase-expressing vaccinia virus while subcloning the gene of interest into a plasmid transfer vector (UNITS 16.16 & 16.17).
2. Infect cells with vaccinia virus and transfect with the recombinant plasmid (UNIT 16.17).
3. Lyse the cells and plaque the virus under suitable selection or screening conditions (UNIT 16.17).
4. Pick plaques and confirm the presence and/or expression of the foreign gene (UNIT 16.18).
5. Amplify the plaque and prepare recombinant virus stock (UNIT 16.17).
6. Infect cells and analyze proteins synthesized (UNIT 16.18).

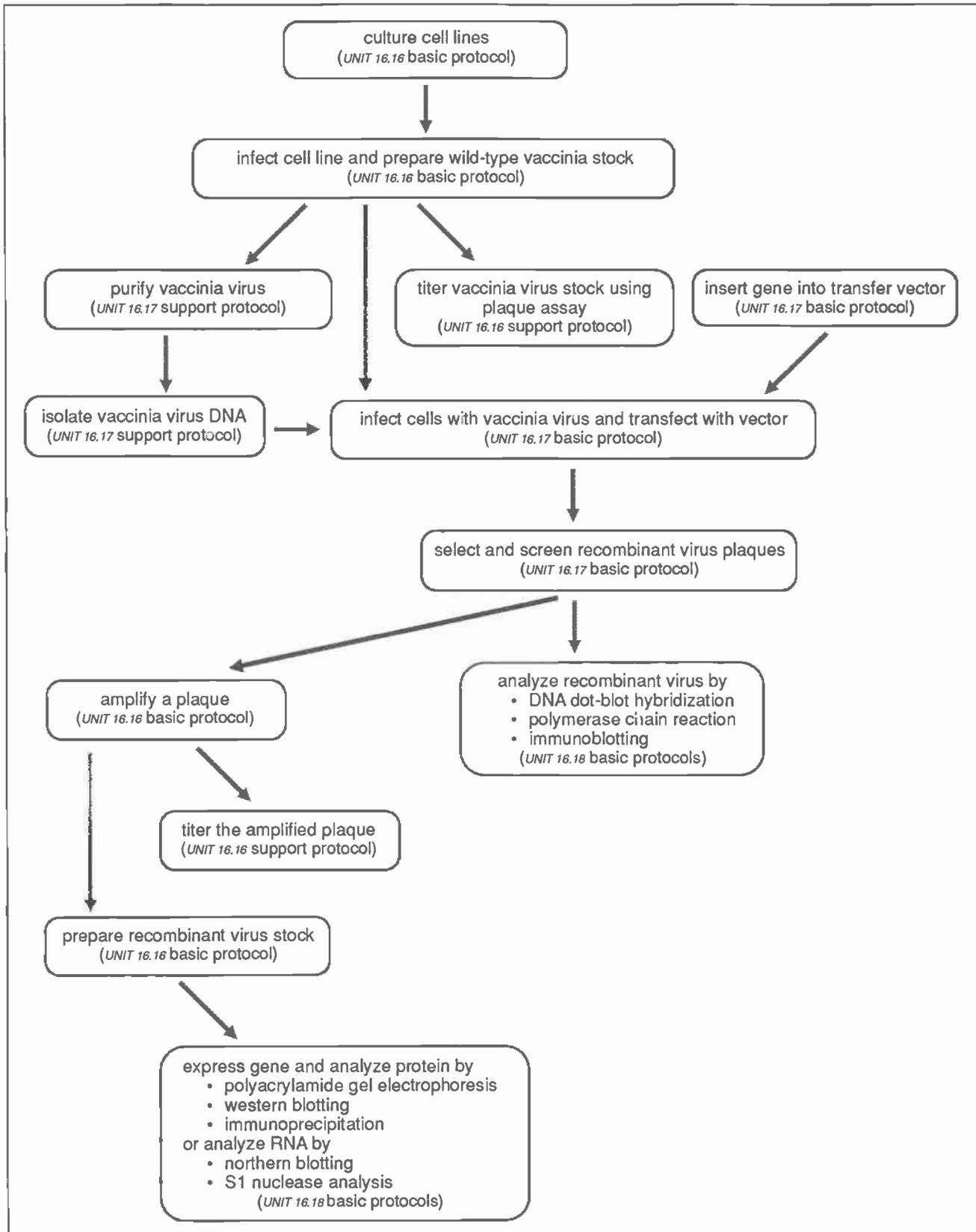

**Figure 16.15.2** Flowchart showing protocols used to express genes using the recombinant vaccinia virus system.

**Overview of the  
Vaccinia Virus  
Expression System**

**16.15.4**

## SAFETY PRECAUTIONS FOR USING VACCINIA

Vaccinia virus is not to be confused with either variola virus, another member of the Orthopoxvirus genus that caused smallpox prior to its eradication, or with varicella virus, a herpes virus that causes chicken pox. Vaccinia virus was used as a live vaccine to prevent smallpox and therefore many of us already have been immunized with vaccinia. A residual scar, commonly on the upper arm, may be evidence of that vaccination.

To prevent laboratory infections, the Centers for Disease Control (CDC) and the National Institutes of Health (NIH) recommend that all individuals who come in contact with vaccinia virus receive vaccinations at 10-year intervals. The CDC has supplied vaccine for such purposes when requested by qualified health workers. Eczema or an immunodeficiency disorder in the laboratory worker or a close contact, however, may be a contraindication to vaccination *which should only be given under medical supervision*. Recently, the benefits of routine vaccination for healthy investigators have also been questioned (Wenzel and Nettelman, 1989; Baxby, 1989). Vaccinia virus is very stable and parenteral inoculation, ingestion, and droplet or aerosol exposure of mucous membranes are the primary hazards to laboratory or animal care personnel. Standard safety level 2 (BL-2) practices and class I or II biological safety cabinets should be employed (Richardson and Barkley, 1988). Institutional biosafety offices should be contacted to determine current policy regarding vaccination and physical containment.

Additional precautions may be necessary for expression of certain genes such as toxins or large segments of other viral genomes, and guidelines for recombinant DNA work should be consulted. Approval of local biosafety committees may be necessary.

## Literature Cited

- Bennink, J.R. and Yewdell, J.W. 1990. Recombinant vaccinia viruses as vectors for studying T lymphocyte specificity and function. *Curr. Topics Microbiol. Immunol.* 163:153-184.
- Baxby, D. 1989. Smallpox vaccination for investigators. *Lancet.* 2:919.
- Earl, P.L., Hügin, A.W., and Moss, B. 1990. Removal of cryptic poxvirus transcription termination signals from the human immunodeficiency virus type 1 envelope gene enhances expression and immunogenicity of a recombinant vaccinia virus. *J. Virol.* 64:2448-2451.
- Mackett, M., Smith, G.L., and Moss, B. 1982. Vaccinia virus: A selectable eukaryotic cloning and expression vector. *Proc. Natl. Acad. Sci. U.S.A.* 79:7415-7419.
- Panicali, D. and Paoletti, E. 1982. Construction of poxviruses as cloning vectors: Insertion of the thymidine kinase gene from herpes simplex virus into the DNA of infectious vaccinia virus. *Proc. Natl. Acad. Sci. U.S.A.* 79:4927-4931.
- Richardson, J.H. and Barkley, W.E. 1988. Biosafety in Microbiological and Biomedical Laboratories. Health and Human Services Publication #(NIH) 88-8395, U.S. Government Printing Office, Washington, D.C.
- Wenzel, R.P. and Nettelman, M.D. 1989. Smallpox vaccination for investigators using vaccinia recombinants. *Lancet.* 2:630-631.

## Key References

- Moss, B. 1990a. Poxviridae and their replication. *In* Virology (B.N. Fields, D.M. Knipe, R.M. Chanock, M.S. Hirsch, J.L. Melnick, T.P. Monath, and B. Roizman, eds.) pp. 2079-2111. Raven Press, New York.
- Moss, B. 1990b. Regulation of vaccinia virus transcription. *Annu. Rev. Biochem.* 59:661-688.
- Provides a description of capping, methylation, and polyadenylation.*
- Moss, B. and Flexner, C. 1987. Vaccinia virus expression vectors. *Annu. Rev. Immunol.* 5:305-325.

---

Contributed by Bernard Moss  
and Patricia L. Earl  
National Institute of Allergy  
and Infectious Diseases  
Bethesda, Maryland

# Preparation of Cell Cultures and Vaccinia Virus Stocks

The first and second basic protocols describe the maintenance of cell lines used with vaccinia virus. Some of these cell lines are then used in the third basic protocol to prepare a vaccinia virus stock. A support protocol provides a method for determining the virus titer using a plaque assay.

Because vaccinia virus has a broad host range, there is considerable latitude in the selection of cell lines; those described in the first two basic protocols below have been found to give good results. BS-C-1 cells give the best results for a plaque assay whereas HeLa cells are preferred for preparation of virus stocks. CV-1 cells can be used for both procedures, but they are generally used for transfection (UNIT 16.17). Human TK<sup>-</sup> 143B cells are used when TK selection is employed (UNIT 16.17), but they can be used for transfection as well as for a plaque assay. Table 16.16.1 presents a summary of the uses for specific cell lines.

**NOTE:** Carry out all procedures in this unit using sterile technique, preferably in a tissue culture hood.

## BASIC PROTOCOL

### CULTURE OF MONOLAYER CELLS

Frozen cells are thawed and grown in appropriate complete medium containing twice the maintenance amount of serum (see below). When the cells are confluent, they are treated with trypsin/EDTA, diluted, and maintained in appropriate complete medium containing 10% FCS (see Table 16.16.2).

#### Materials

Frozen ampule of cells (Table 16.16.1): BS-C-1 (ATCC #CCL26), CV-1 (ATCC #CCL70), or HuTK<sup>-</sup> 143B (ATCC #CRL8303) cells

70% ethanol

Start-up medium (Table 16.16.2): complete MEM-20, complete DMEM-20, or complete MEM-20/BrdU

Maintenance medium (Table 16.16.2): complete MEM-10, complete DMEM-10, or complete MEM-10/BrdU

**Table 16.16.1** Cell Lines Used in Specific Vaccinia Protocols

Cell line	Use <sup>a</sup>	Procedure
HeLa S3	Virus stock preparation	UNIT 16.16 basic protocol
	Purification of vaccinia virus	UNIT 16.17 support protocol
	Amplification of a plaque	UNIT 16.17 basic protocol
BS-C-1	Plaque assay	UNIT 16.16 support protocol
	XGPRT selection	UNIT 16.17 basic protocol
CV-1	Transfection	UNIT 16.17 basic protocol
	Virus stock preparation (optional)	UNIT 16.16 basic protocol
	Plaque assay (optional)	UNIT 16.16 support protocol
HuTK <sup>-</sup> 143B	TK selection	UNIT 16.17 basic protocol
	Plaque assay (optional)	UNIT 16.16 support protocol
	Transfection (optional)	UNIT 16.17 basic protocol

<sup>a</sup>The preferred use(s) for each cell line is listed first; if optional is indicated, the cell line can be used for the indicated procedure but the results may not be as good as those from the preferred cell line.

Phosphate-buffered saline (PBS; *APPENDIX 2*; optional)  
 0.25% trypsin/0.02% EDTA (trypsin/EDTA; Quality Biological #18-112-1), 37°C  
 25-cm<sup>2</sup> and 150-cm<sup>2</sup> flasks  
 Humidified 37°C, 5% CO<sub>2</sub> incubator

***Begin the culture***

1. Thaw the frozen ampule of cells in a 37°C water bath.
2. Sterilize the ampule tip with 70% ethanol, break the neck, and transfer the cells with a pipet into a 25-cm<sup>2</sup> flask containing 5 ml of start-up medium. Rotate the flask to evenly distribute the cells and place overnight in a CO<sub>2</sub> incubator at 37°C.
3. Aspirate the start-up medium and replace with appropriate maintenance medium. Return cells to the CO<sub>2</sub> incubator at 37°C and check daily for confluency. When the cells are a confluent monolayer, trypsinize and transfer to a 150-cm<sup>2</sup> flask as in steps 4 to 8.

*Cells should be passaged when they become confluent. Generally, if cells are split 1:20, they reach confluence in 1 week and need not be counted.*

***Maintain the culture***

4. Aspirate medium from a confluent cell monolayer.
5. Wash cells once with PBS or trypsin/EDTA by covering cells with the solution and pipetting it off (to remove remaining serum from the cells).
6. Overlay cells with 37°C trypsin/EDTA using a volume that is just enough to cover the monolayer (e.g., 1.5 ml for a 150-cm<sup>2</sup> flask). Allow to sit 30 to 40 sec (cells should become detached) and shake the flask to completely detach cells.
7. Add 8.5 ml appropriate maintenance medium. Pipet the cell suspension up and down several times to disrupt clumps (these cells are ready for passage).
8. Remove 0.5 ml of cell suspension and add it to a new 150-cm<sup>2</sup> flask containing 30 ml maintenance medium. Rotate the flask to evenly distribute the cells and place in a CO<sub>2</sub> incubator at 37°C until the cells are confluent (~1 week). Maintain the cells by splitting ~1:20 in maintenance medium at approximately weekly intervals.

*Cells can be maintained in smaller flasks if desired. If so, volumes should be adjusted proportionately.*

**Table 16.16.2** Media Used for Growth and Maintenance of Cell Lines<sup>a</sup>

Cell line	Maintenance medium <sup>a</sup>	Start-up medium <sup>a</sup>
BS-C-1	Complete MEM-10	Complete MEM-20
CV-1	Complete DMEM-10	Complete DMEM-20
HuTK <sup>-</sup> 143B	Complete MEM-10/BrdU	Complete MEM-20/BrdU
HeLa S3	Complete spinner medium-5	Complete MEM-10

<sup>a</sup>See reagents and solutions for recipes.

## **CULTURE OF SUSPENSION CELLS**

HeLa S3 cells are maintained in complete spinner medium-5.

### **Materials**

HeLa S3 cells (ATCC #CCL2.2)  
Complete MEM-10  
Complete spinner medium containing 5% horse serum (complete spinner medium-5)  
0.25% trypsin/0.02% EDTA (trypsin/EDTA; Quality Biological #18-112-1), 37°C  
25-cm<sup>2</sup> flasks  
Humidified 37°C, 5% CO<sub>2</sub> incubator  
50-ml centrifuge tubes  
Sorvall H-6000A rotor (or equivalent)  
100- or 200-ml vented spinner bottles (Bellco #1965) and caps with filters (Bellco #A523-A59)  
Hemocytometer (UNIT 1.2)

### **Begin the culture**

1. Thaw frozen ampule of cells and transfer to a 25-cm<sup>2</sup> flask as in steps 1 and 2 of the first basic protocol, using 5 ml complete MEM-10. Place overnight in a CO<sub>2</sub> incubator at 37°C.
2. Aspirate medium. Overlay with 0.5 ml of 37°C trypsin/EDTA; let sit 30 to 40 sec.  
*Since these cells do not attach firmly to the flask, they should not be washed prior to trypsinization.*
3. Add 10 ml complete spinner medium-5 and transfer cells to a 50-ml centrifuge tube. Centrifuge 5 min in a Sorvall H-6000A rotor at 2500 rpm (1800 × g), room temperature, and discard supernatant.
4. Suspend cell pellet in 5 ml complete spinner medium-5 by pipetting up and down to disrupt clumps.
5. Add 50 ml complete spinner medium-5 to a 100- or 200-ml vented spinner bottle and transfer cell suspension to this bottle.
6. Remove 1 ml cell suspension and count the cells using a hemacytometer. Add complete spinner medium-5 to adjust the cell density to 3-4 × 10<sup>5</sup> cells/ml. Place cells in a 37°C incubator without CO<sub>2</sub> and stir continuously.  
*The initial high density is used because some cells are not viable.*
7. At daily intervals, count cells again and add complete spinner medium-5 to adjust concentration to 3-4 × 10<sup>5</sup> cells/ml. Return cells to incubator—when cells have grown for 2 successive days, proceed to steps 8 to 9.

### **Maintain the culture**

8. Remove 1 ml cell suspension and count the cells using a hemacytometer.
9. When the density is 4-5 × 10<sup>5</sup> cells/ml, dilute the cells to 1.5 or 2.5 × 10<sup>5</sup> cells/ml with complete spinner medium-5 for alternate day or daily feeding respectively. Place vented spinner bottle containing cells in 37°C incubator without CO<sub>2</sub> and stir continuously. Passage every 1 to 2 days.

*HeLa S3 cells are grown and maintained in complete spinner medium-5 in vented spinner bottles at 37°C without CO<sub>2</sub>. Cells are diluted with fresh medium at 1- to 2-day intervals to keep the cell density between 1.5 × 10<sup>5</sup> and 5 × 10<sup>5</sup> cells/ml. Horse serum is used because it is cheaper than FCS and may give less cell clumping.*

## PREPARATION OF A VACCINIA VIRUS STOCK

To prepare a vaccinia virus stock, HeLa S3 cells from a spinner culture are plated the day before infection and allowed to attach. They are then infected with trypsinized virus. After several days, the infected cells are harvested and lysed during repeated freeze-thaw cycles. The virus stock is then aliquotted and stored at  $-70^{\circ}\text{C}$ . The support protocol describes how to titer this stock.

*Materials*

HeLa S3 cells from suspension culture (second basic protocol)  
Complete MEM-10 and -2.5,  $37^{\circ}\text{C}$   
Vaccinia virus (ATCC #VR1354 or other source)  
0.25 mg/ml trypsin (2 $\times$  crystallized and salt-free; Worthington; filter sterilize and store at  $-20^{\circ}\text{C}$ )  
Hemocytometer (UNIT 1.2)  
Sorvall H-6000A rotor (or equivalent)  
150-cm<sup>2</sup> tissue culture flask

1. Count HeLa S3 cells from a suspension culture using a hemacytometer.
2. Centrifuge  $5 \times 10^7$  cells 5 min in an H-6000A rotor at 2500 rpm (1800  $\times$  g), room temperature, and discard supernatant.
3. Resuspend cells in 25 ml of  $37^{\circ}\text{C}$  complete MEM-10, dispense in one 150-cm<sup>2</sup> flask, and place overnight in a CO<sub>2</sub> incubator at  $37^{\circ}\text{C}$  (for infection the following day).

*Increase the number of HeLa cells proportionately if more than one 150-cm<sup>2</sup> flask is to be infected.*

4. Just prior to use, mix an equal volume of vaccinia virus stock and 0.25 mg/ml trypsin, and vortex vigorously. Incubate 30 min in a  $37^{\circ}\text{C}$  water bath, vortexing at 5- to 10-min intervals during the incubation.

*Virus stocks are usually at a titer of  $\sim 2 \times 10^9$  pfu/ml but may be significantly lower depending on the source.*

*Vortexing usually breaks up any clumps of cells. However, if there are still visible clumps, chill to  $0^{\circ}\text{C}$  and sonicate 30 sec on ice (UNIT 16.17). Sonication can be repeated several times but the sample should be allowed to cool on ice between sonications.*

5. Dilute trypsinized virus in complete MEM-2.5 to  $2.5\text{--}7.5 \times 10^7$  pfu/ml. Decant or aspirate medium from the 150-cm<sup>2</sup> flask of HeLa cells and add 2 ml diluted, trypsinized virus. Place 2 hr in a CO<sub>2</sub> incubator at  $37^{\circ}\text{C}$ , rocking flask by hand at 30-min intervals.

*The optimal multiplicity of infection (MOI) is 1 to 3 pfu/HeLa cell. Multiplicities of 0.1 pfu/HeLa cell may be necessary if the titer of the initial virus stock is low. The trypsinized virus must be diluted  $\geq 10$ -fold to avoid detaching the cells.*

6. Overlay cells with 25 ml complete MEM-2.5 and place 3 days in a CO<sub>2</sub> incubator at  $37^{\circ}\text{C}$ .
7. Detach the infected cells from the flask by shaking and pour or pipet into a sterile plastic screw-cap tube. Centrifuge 5 min at 1800  $\times$  g,  $5^{\circ}$  to  $10^{\circ}\text{C}$ , and discard supernatant.
8. Resuspend cells in 2 ml complete MEM-2.5 (per 150-cm<sup>2</sup> flask) by gently pipetting or vortexing.

**SUPPORT  
PROTOCOL**

9. Lyse the cell suspension by freeze-thaw cycling as follows: freeze in dry ice/ethanol, thaw in a 37°C water bath, and vortex. Carry out the freeze-thaw cycling a total of three times.
10. Keep the virus stock on ice while dividing it into 0.5- to 2-ml aliquots. Store the aliquots at -70°C.

**TITERING A VACCINIA VIRUS STOCK USING A PLAQUE ASSAY**

Serial dilutions of the trypsinized virus stock prepared as described in the third basic protocol are used to infect the appropriate cell line. After several days growth, the medium is removed and the cells are stained with crystal violet. Plaques appear as 1- to 2-mm-diameter areas of diminished staining due to the retraction, rounding, and detachment of infected cells.

*Additional Materials*

- BS-C-1 cells from confluent monolayer culture (first basic protocol)
- Virus stock (third basic protocol)
- 0.1% crystal violet (Sigma #C3886) in 20% ethanol (store indefinitely at room temperature)
- 6-well 35-mm tissue culture dishes

1. Trypsinize confluent monolayer of BS-C-1 cells as described in steps 4 to 7 of the first basic protocol.
2. Count the cells using a hemacytometer.
3. Seed wells of 6-well tissue culture dishes with BS-C-1 cells in complete MEM-10 to  $5 \times 10^5$  cells per well—each well should contain 2 ml. Place overnight in a CO<sub>2</sub> incubator at 37°C to reach confluency.
4. Trypsinize virus stock as in step 4 of the third basic protocol.
5. Make nine 10-fold serial dilutions (*UNIT 1.11*) of the trypsinized virus in complete MEM-2.5, using a fresh pipet for each dilution.
6. Remove medium from BS-C-1 cells and infect cells in duplicate wells with 0.5 ml of the 10<sup>-7</sup>, 10<sup>-8</sup>, and 10<sup>-9</sup> trypsinized virus dilutions. Place 1 to 2 hr in a CO<sub>2</sub> incubator at 37°C, rocking dish at 15- to 30-min intervals to keep cells moist.
7. Overlay cells in each well with 2 ml complete MEM-2.5 and place 2 days in a CO<sub>2</sub> incubator at 37°C.
8. Remove medium and add 0.5 ml of 0.1% crystal violet to each well. Incubate 5 min at room temperature.
9. Aspirate crystal violet and allow wells to dry.
10. Determine the titer by counting plaques within the wells and multiplying by the dilution factor.

*Most accurate results are obtained from wells with 20 to 80 plaques. In determining the titer, take into account the 1:1 dilution of the virus stock with trypsin.*

## REAGENTS AND SOLUTIONS

### **Complete DMEM-10 or -20**

*Dulbeccos minimum essential medium (DMEM; Quality Biological #12-103-5) containing:*

10% or 20% fetal calf serum (FCS; Hazelton Biologics #12-10378)  
0.03% glutamine  
100 U/ml penicillin and 100 µg/ml streptomycin sulfate

Add supplements from stock solutions prepared in water at the following initial concentrations: 3% glutamine (100×; Research Plus), and 20,000 U/ml penicillin and 20 mg/ml streptomycin (200×; ICN Immunobiologicals). Filter sterilize stock solutions. Store 100× glutamine 4 months at 4°C and 200× penicillin/streptomycin 4 months at -20°C.

*Fetal calf serum is added at 10% to complete medium for maintenance of cells and at 20% to encourage initial growth upon thawing. See Chapter 9 introduction for a full discussion concerning media preparation and use of serum (heat-inactivation, screening, etc.).*

### **Complete MEM-2.5, -10, or -20**

*Minimum essential medium (MEM; Quality Biological #12-106-5) containing:*

2.5%, 10%, or 20% FCS (Hazelton Biologics #12-10378)  
0.03% glutamine  
100 U/ml penicillin and 100 µg/ml streptomycin sulfate

*Add supplements from stock solutions as described above for complete DMEM. See also annotation to DMEM recipe concerning growth versus maintenance levels of serum.*

### **Complete MEM-10/BrdU or -20/BrdU**

Prepare as for complete MEM-10 or -20 (see above) and add 5 mg/ml of 5-bromodeoxyuridine (BrdU) to 25 µg/ml final. Prepare the 5 mg/ml BrdU stock solution (200×) in water and filter sterilize. Store in the dark at -20°C. After thawing 5 mg/ml BrdU, vortex to be sure it is in solution before adding to MEM.

### **Complete spinner medium-5**

MEM spinner medium (Quality Biological #12-209-SP)  
5% horse serum (Hazelton Biologics #12-44978)

*Supplements are supplied in MEM spinner medium by Quality Biological.*

## COMMENTARY

### **Background Information**

An overview of the vaccinia life cycle and expression system is presented in *UNIT 16.15*.

Because HeLa cells consistently give high yields of virus, they are routinely used for preparation of virus stocks. HeLa S3 cells as obtained from the ATCC grow well in monolayer culture but can be put into suspension culture. After repeated passages in suspension, they do not adhere well to flasks and grow poorly in monolayer cultures. Our laboratory prefers HeLa cells adapted to suspension culture because large numbers can be grown in a single bottle. However, suspension cultures require more maintenance than

monolayer cultures and the latter may be preferred.

Suspension cells are allowed to form a monolayer before infection to increase the chances of cell-to-cell spread if not all cells are infected with the viral inoculum. Thus, good yields of virus may be obtained even if the inoculum is <1 pfu/cell. HeLa cells—even those adapted to monolayer culture—are fairly round to begin with and therefore show little visible evidence of infection. BS-C-1 cells, by contrast, are long and spindle-shaped but round up dramatically a few hours after infection. This property accounts for the highly visible plaques obtained with BS-C-1 cells.

The Western Reserve (WR) strain of vaccinia virus (ATCC #VR1354) is widely used for laboratory studies. It gives high yields of cell-associated virus, discrete plaques, and is well adapted to mice and other laboratory animals. Other strains of vaccinia virus are available from the ATCC and private sources.

Horse serum is used for growth of HeLa cells in suspension because it is cheaper than FCS and may give less cell clumping. Horse serum is used in spinner medium for growth of HeLa cells in suspension. All monolayer cells are grown in medium with FCS.

### Critical Parameters

Proper maintenance of actively growing cell lines is important in order to achieve efficient infections and high yields of virus. This is especially true for HeLa S3 cell suspension cultures which should be maintained at  $1.5-5 \times 10^5$  cells/ml; this requires passaging every 1 to 2 days. HeLa cells can achieve a density of  $8-10 \times 10^5$  cells/ml, but upon dilution there will be a lag before optimal growth is resumed; prolonged maintenance at high density will lead to cell death. HeLa S3 cells adapted to grow in suspension cultures do not grow well in monolayer cultures. However, the cells will adhere to flasks, which allows the cells to be infected on the following day using the third basic protocol.

Since most progeny viruses remain cell-associated, infected cells must be disrupted by freeze-thaw cycling and trypsinization. These procedures are important for releasing virus from the host cells. An entire stock of virus can be subjected to freeze-thaw cycling but only the portion to be used should be trypsin-

ized. Sonication also helps in disaggregating virus but is usually unnecessary if the virus stock has been trypsinized.

Although vaccinia virus is relatively stable, stocks should be kept on ice while in use and should be stored at  $-70^\circ\text{C}$ . A vaccinia virus stock should have a stable titer for many years when stored at this temperature. Although the stock can be frozen and thawed several times without loss of infectivity, storing in aliquots is recommended.

### Anticipated Results

A vaccinia stock should have a titer of  $\geq 1-2 \times 10^9$  pfu/ml. The viral stock should have a stable titer for many years when stored as indicated above.

### Time Considerations

Actively growing cells should be prepared in advance, as it will take  $\geq 1$  week to revive frozen cells. For preparation of a vaccinia virus stock, infected cells should be incubated for 3 days. During this period, the BS-C-1 cells for plaque titration can be prepared. For a small volume of stock (i.e., from one 150-cm<sup>2</sup> flask), harvesting and freeze-thaw cycling can be done in  $< 1$  hr. Determination of the titer of a virus stock requires 2 days of incubation to allow for development of plaques.

---

Contributed by Patricia L. Earl, Norman Cooper, and Bernard Moss  
National Institutes of Allergy  
and Infectious Diseases  
Bethesda, Maryland

# Generation of Recombinant Vaccinia Viruses

UNIT 16.17

The first basic protocol describes how to infect cells with wild-type vaccinia virus and then transfect them with a plasmid-transfer vector to generate a recombinant virus. The first support protocol presents a method for purifying vaccinia virus, and the second support protocol provides a method for isolating viral DNA, which can be used during transfection. Selection and screening methods used to obtain isolated plaques are presented in the second basic protocol. The third basic protocol describes how the isolated plaques can be amplified.

HeLa S3 cells are used for large-scale growth of vaccinia virus. However, several other cell lines may be required for plaque purification and amplification. For TK selection, HuTK<sup>-</sup> 143B cells are used; for XGPRT selection, BS-C-1 cells are used. CV-1 cells are used for transfection. BS-C-1 or CV-1 cells can be used for determination of virus titer (UNIT 16.16).

**CAUTION:** Proceed carefully and follow biosafety level 2 (BL-2) practices when working with vaccinia virus (UNIT 16.15 for safety precautions).

**NOTE:** Carry out all procedures for preparation of virus in a tissue culture hood.

## TRANSFECTION OF INFECTED CELLS WITH A VACCINIA VECTOR

**BASIC  
PROTOCOL**

The foreign gene of interest is subcloned into a plasmid transfer vector (Figs. 16.17.1-16.17.4) so that it is flanked by DNA from a nonessential region of the vaccinia genome. This recombinant plasmid is then transfected into cells that have been infected with wild-type vaccinia virus. Homologous recombination between the vaccinia and plasmid DNA generates a recombinant virus (Fig. 16.17.1). The recombinant virus is obtained in a cell lysate which is then subjected to several rounds of plaque purification using appropriate selection and/or screening protocols (second basic protocol).

### Materials

pSC11, pMJ601, pTKgptF1S, or other suitable vector (Table 16.17.1;

Figs. 16.17.2-16.17.4)

CV-1 cells (UNIT 16.16)

Complete minimum essential medium containing 10% and 2.5% fetal calf serum (complete MEM-10 and -2.5; UNIT 16.16)

Wild-type vaccinia virus stock (UNIT 16.16)

0.25 mg/ml trypsin (2× crystallized and salt-free; Worthington; filter sterilize and store at -20°C)

Transfection buffer

2.5 M CaCl<sub>2</sub>

25-cm<sup>2</sup> tissue culture flask

Humidified 37°C, 5% CO<sub>2</sub> incubator

12 × 75-mm polystyrene tube

Disposable scraper or rubber policeman, sterile

Sorvall H-6000A rotor (or equivalent)

Additional reagents and equipment for subcloning (UNIT 3.16)

1. Subclone the gene of interest into the polylinker in pSC11, pMJ601, pTKgptF1S, or other suitable vector.
2. Seed a 25-cm<sup>2</sup> flask with 1 × 10<sup>6</sup> CV-1 cells in complete MEM-10. Place in a CO<sub>2</sub> incubator at 37°C and grow to near confluency (usually overnight).

**Protein  
Expression**

**16.17.1**

**Table 16.17.1** Vaccinia Virus Transfer Vectors

Vector	Promoter <sup>a</sup>	Unique restriction sites	Flanking DNA	Selection/screening	Reference
pGS20	<i>p</i> <sub>7.5</sub> (E/L)	<i>Bam</i> HI, <i>Sma</i> I <sup>b</sup>	TK	TK <sup>-</sup>	Mackett et al., 1984
pGS61	<i>p</i> <sub>7.5</sub>	<i>Bam</i> HI, <i>Hind</i> III	TK	TK <sup>-</sup>	Smith et al., 1987
pGS62	<i>p</i> <sub>7.5</sub>	<i>Bam</i> HI, <i>Sma</i> I, <i>Eco</i> RI	TK	TK <sup>-</sup>	Smith et al., 1987
pVV3	<i>p</i> <sub>7.5</sub>	Polylinker	TK	TK <sup>-</sup>	Rice et al., 1985
pBCB01, 2, 3 <sup>c</sup>	<i>p</i> F	Polylinker	TK	TK <sup>-</sup>	Boyle et al., 1989
pBCB06	<i>p</i> <sub>7.5</sub>	Polylinker	TK	TK <sup>-</sup>	Boyle et al., 1989
pSC11 <sup>d</sup>	<i>p</i> <sub>7.5</sub>	<i>Sma</i> I <sup>b</sup>	TK	TK <sup>-</sup> /β-gal	Chakrabarti et al., 1985
pSC11ss <sup>d</sup>	<i>p</i> <sub>7.5</sub>	<i>Stu</i> I, <i>Sal</i> I	TK	TK <sup>-</sup> /β-gal	Earl et al., 1990
pCF11	<i>p</i> <sub>7.5</sub>	<i>Sma</i> I <sup>b</sup>	<i>Hind</i> III C	β-gal	Flexner et al., 1987
pYF6	<i>p</i> <sub>7.5</sub>	<i>Sma</i> I <sup>b</sup>	HA	HA <sup>-</sup> , β-gal	Flexner et al., 1987
pPro18	<i>p</i> <sub>7.5</sub>	<i>Sma</i> I <sup>b</sup>	HA	HA <sup>-</sup>	Shida et al., 1987
pTK-7.5A	<i>p</i> <sub>7.5</sub>	Polylinker	<i>Hind</i> III <sup>e</sup> F	TK <sup>+</sup>	Coupar et al., 1988
pTK-7.5B	<i>p</i> <sub>7.5</sub>	Polylinker	<i>Hind</i> III F	TK <sup>+</sup>	Coupar et al., 1988
pUVI	<i>p</i> <sub>11</sub> (L)	Polylinker <sup>f</sup>	TK	TK <sup>-</sup> /β-gal	Falkner et al., 1987
pTK-gpt-F1s, 2s, 3s <sup>d</sup>	<i>p</i> <sub>11</sub>	Polylinker	TK	TK <sup>-</sup> or gpt	Falkner & Moss, 1988
pJ16 <sup>f</sup>	<i>P</i> <sub>11</sub> , <i>P</i> <sub>25</sub> (E)	Multiple	TK	TK <sup>-</sup>	Tsao et al., 1988
p1200	CAE I (L)	<i>Cla</i> I	TK	TK <sup>-</sup>	Patel et al., 1988
pMP528HRH	<i>p</i> H6 (E/L)	<i>Xho</i> I, <i>Kpn</i> I, <i>Sma</i> I <sup>b</sup>	<i>Hind</i> III K	Host range	Perkus et al., 1989
pHES1, 2, 3	<i>p</i> H6	Polylinker <sup>g</sup>	<i>Hind</i> III K	Host range	Perkus et al., 1989
pHES4	<i>p</i> H6	Polylinker	<i>Hind</i> III K	Host range	Perkus et al., 1989
pMJ601 <sup>d</sup>	Synthetic (L)	Polylinker	TK	TK <sup>-</sup> /β-gal	Davison & Moss, 1990
pMJ602	Synthetic (L)	Polylinker	TK	TK <sup>-</sup> /β-gal	Davison & Moss, 1990
pSC59	Synthetic (E/L)	Polylinker	TK	TK <sup>-</sup>	Chakrabarti & Moss, unpub. obs.
pSC65	Synthetic (E/L)	Polylinker	TK	TK <sup>-</sup> /β-gal	Chakrabarti & Moss, unpub. obs.

<sup>a</sup>E, early; L, late; E/L, early and late.

<sup>b</sup>*Sma*I digestion gives a blunt-end for cloning any fragment that has been blunt-ended.

<sup>c</sup>Initiation codons upstream of polylinker.

<sup>d</sup>Represented in Figures 16.17.2-16.17.4.

<sup>e</sup>Initiation codon immediately precedes *Eco*RI site.

<sup>f</sup>Bidirectional promoters. *p*<sub>11</sub> has consecutive initiation and termination codons.

<sup>g</sup>Three-vector set with translation initiation codon followed by polylinker in all three open-reading-frames.

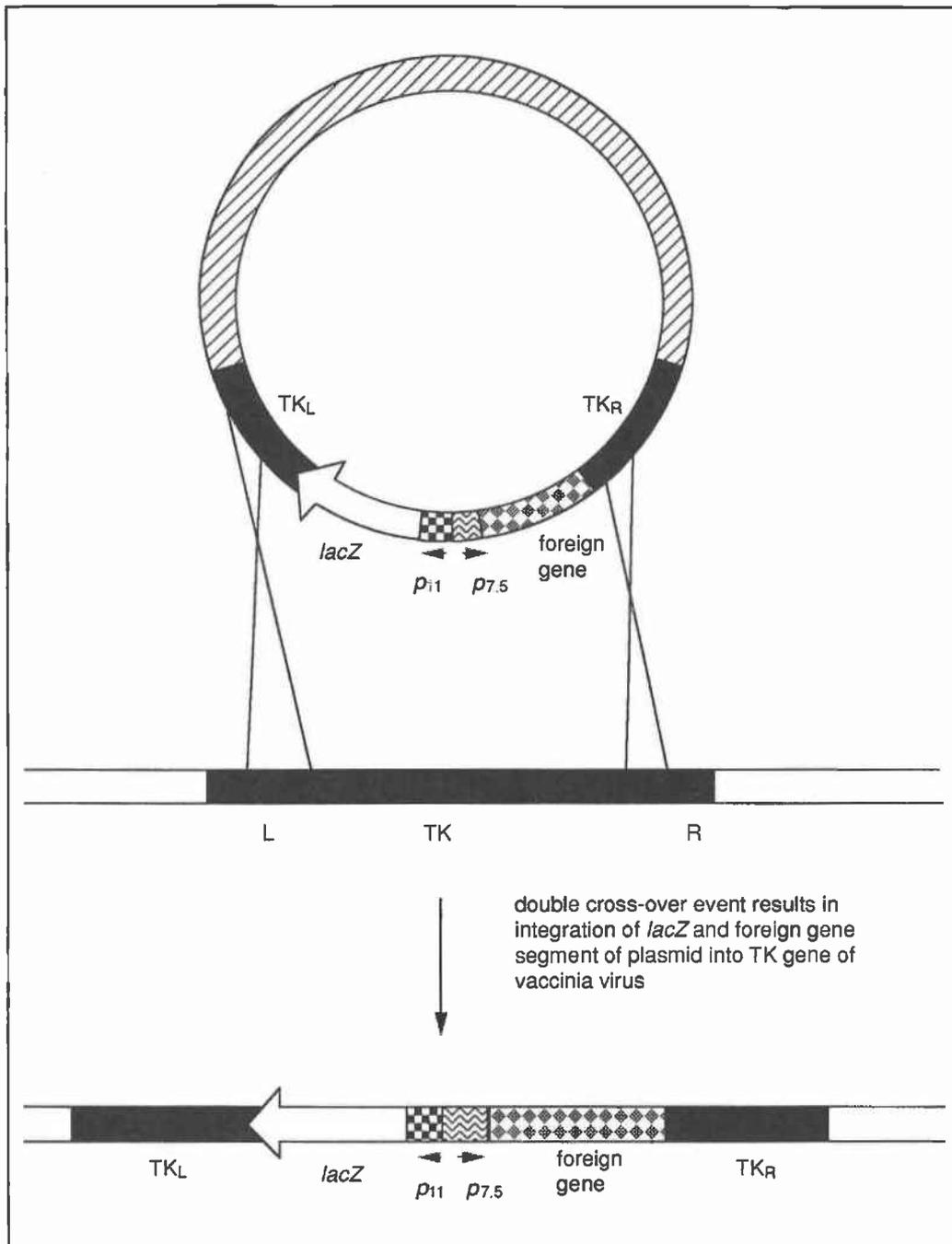
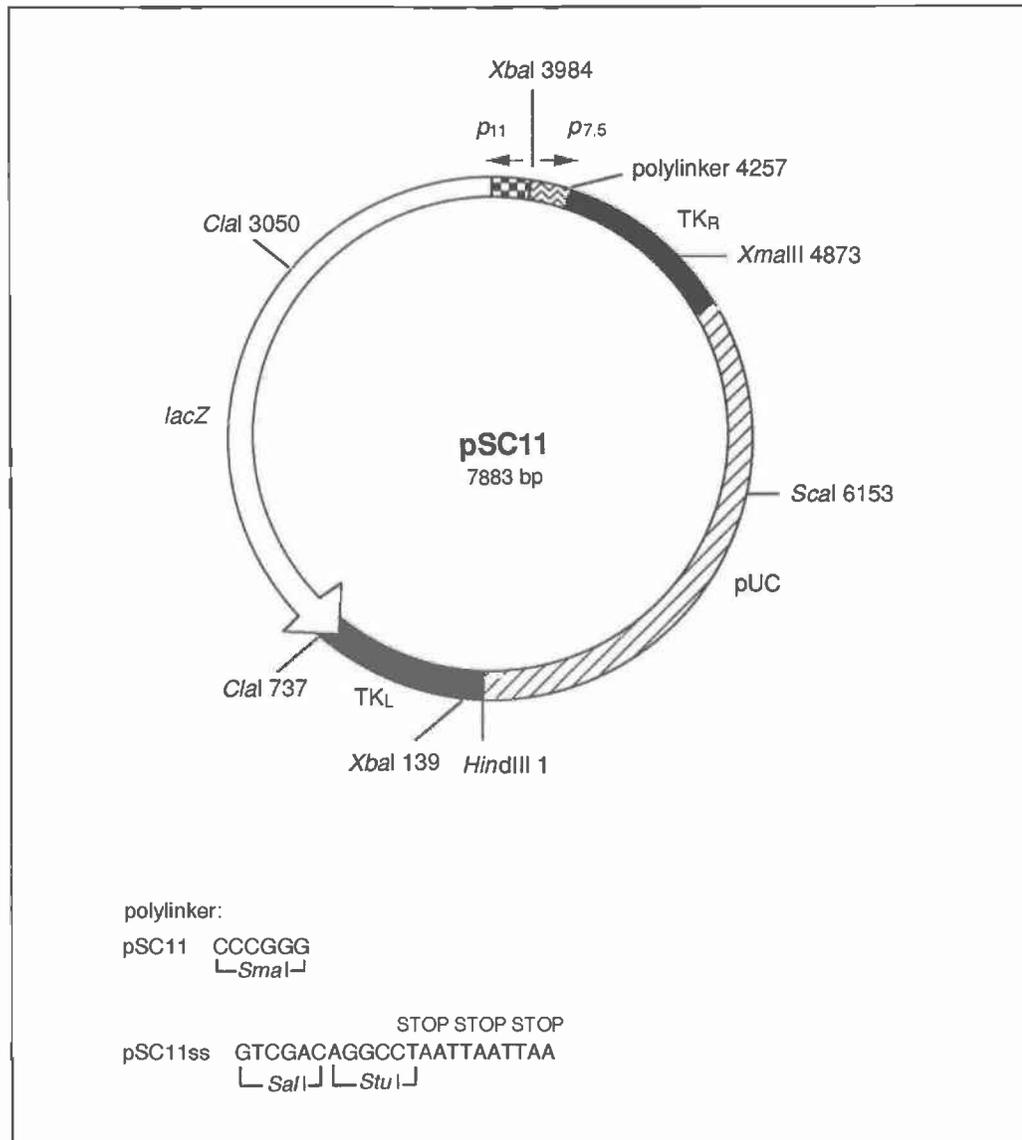

**Figure 16.17.1** Homologous recombination between a transfected plasmid and the vaccinia virus genome. Vaccinia virus DNA sequences—TK<sub>L</sub> (left) and TK<sub>R</sub> (right)—flank the foreign genes. Each foreign gene is controlled by a different vaccinia virus promoter. p<sub>11</sub> is a late promoter derived from a gene encoding an abundant 11-kDa structural protein. p<sub>7.5</sub> is a compound early/late promoter derived from a gene encoding 7.5-kDa protein which is expressed both early and late in vaccinia infection. The function of this gene, which may actually be defective because of a frameshift mutation in the WR strain of vaccinia virus, is unknown. In this figure, *lacZ* and a generic foreign gene are depicted. A double cross-over event occurs between homologous regions of vaccinia virus DNA sequences. This results in the generation of a recombinant virus into which the foreign genes have been inserted.

3. Prepare trypsinized virus as follows: just prior to use, mix an equal volume of wild-type vaccinia virus stock and 0.25 mg/ml trypsin and vortex vigorously. Incubate 30 min in a 37°C water bath, vortexing at 5- to 10-min intervals.

*For detailed information, see step 4 of the basic protocol on preparation of a vaccinia virus stock in UNIT 16.16.*

4. Dilute trypsinized virus in complete MEM-2.5 to  $1.5 \times 10^5$  pfu/ml. Aspirate medium from confluent monolayer of CV-1 cells and infect with 1 ml diluted vaccinia virus (0.05 pfu/cell). Place 2 hr in a CO<sub>2</sub> incubator at 37°C, rocking at ~15-min intervals.
5. Approximately 30 min before the end of the infection period, prepare calcium phosphate-precipitated DNA solution as follows: place 1 ml transfection buffer into a 12 × 75-mm polystyrene tube and add 5 to 10 µg recombinant plasmid DNA (in <50 µl; containing the gene of interest from step 1); slowly add 50 µl of 2.5 M CaCl<sub>2</sub>

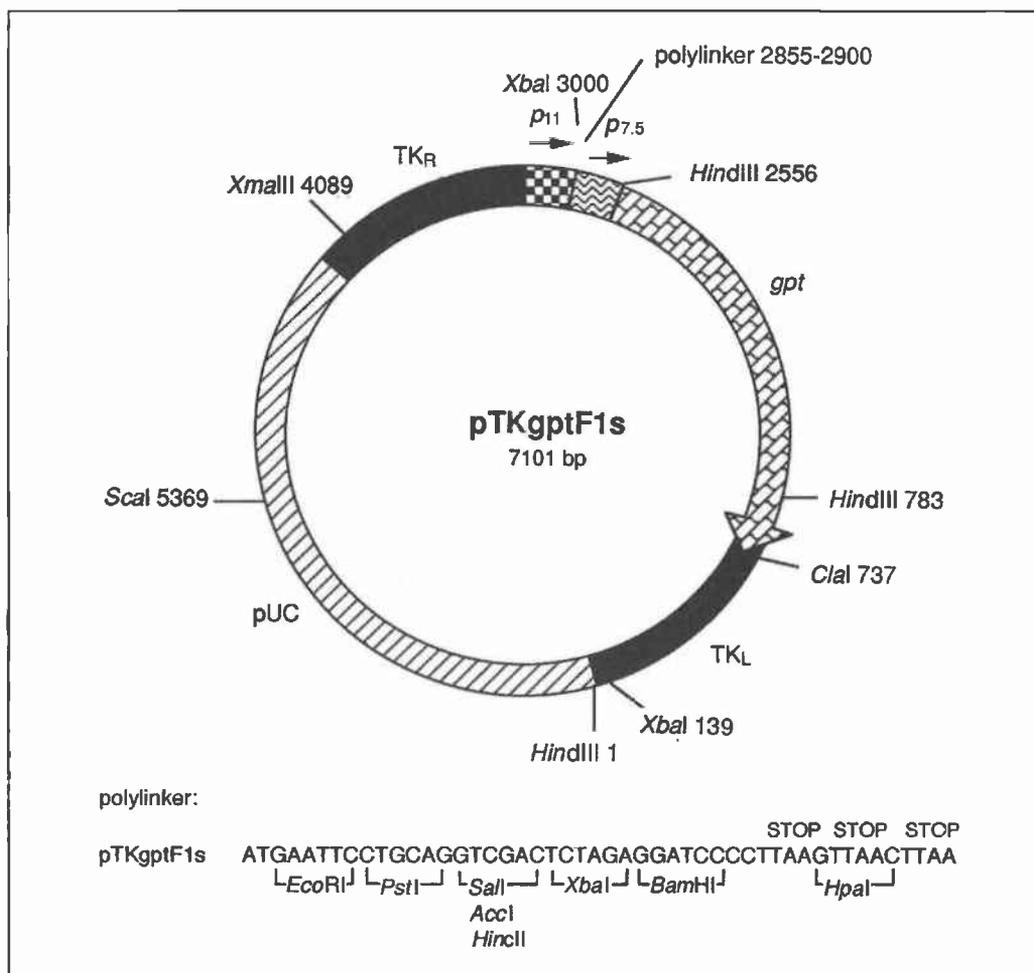

**Figure 16.17.2 pSC11.** pSC11 contains a moderate-strength compound early/late promoter,  $p_{7.5}$ , with one or more unique restriction endonuclease sites for insertion of genes (Chakrabarti et al., 1985). A late vaccinia virus promoter,  $p_{11}$ , is used to express the *E. coli lacZ* gene. The expression cassette is flanked by segments of the vaccinia TK gene. TK selection and  $\beta$ -galactosidase screening can be used for isolation of recombinant virus plaques. Nucleotide numbers for these and other plasmid vectors have been estimated and may not be exact.

and mix gently. Leave 20 to 30 min at room temperature—a fine precipitate should appear.

*Inclusion of wild-type vaccinia DNA (see second support protocol) in the transfection results in a higher efficiency of recombination. If it is added, combine 1 μg wild-type vaccinia DNA with 5 to 10 μg recombinant plasmid DNA and vortex vigorously to shear the high-molecular-weight DNA before adding CaCl<sub>2</sub>. A discussion of calcium phosphate transfection can be found in UNIT 9.1.*

6. Aspirate virus inoculum from monolayer of CV-1 cells (from step 4). Add the precipitated DNA solution (from step 5) and leave 30 min at room temperature.
7. Add 9 ml complete MEM-10 and place 3 to 4 hr in a CO<sub>2</sub> incubator at 37°C.
8. Aspirate medium, replace with 5 ml complete MEM-10, and incubate 2 days in a CO<sub>2</sub> incubator at 37°C.
9. Dislodge cells with a disposable scraper or sterile rubber policeman and transfer to a cone-bottom centrifuge tube. Centrifuge 5 min at 1800 × g (2500 rpm in an H-6000A rotor), 5° to 10°C, and aspirate and discard medium.



**Figure 16.17.3 pTKgptF1s.** pTKgptF1s contains the strong late vaccinia virus promoter, *p*<sub>11</sub>, followed by a polylinker for insertion of protein-coding segments that are in-frame with the ATG (Falkner and Moss, 1988). Additional variants, pTKgptF2s and pTKgptF3s, contain one or two additional G residues, respectively, following the ATG to allow all three phasing possibilities. The *E. coli gpt* gene is regulated by the compound early/late promoter, *p*<sub>7.5</sub>. The expression cassette is flanked by segments of the vaccinia virus TK gene. Either TK or XGPRT selection can be used for isolation of recombinant virus plaques.

10. Resuspend cells in 0.5 ml complete MEM-2.5. Lyse the cell suspension by freeze-thaw cycling as follows: freeze in dry ice/ethanol, thaw in a 37°C water bath, and vortex. Carry out the freeze-thaw cycling a total of three times.
11. Store the cell lysate at -70°C until needed in the selection and screening procedure (second basic protocol).

**SUPPORT  
PROTOCOL**

**PURIFICATION OF VACCINIA VIRUS**

Vaccinia is usually purified by zonal sucrose gradient centrifugation. Purified virus is useful for preparation of vaccinia DNA (second support protocol), studies in which contaminating infected cell proteins are undesirable, and as a very high-titer stock. For large-scale purification, it is preferable to use HeLa cell suspensions for infection rather than monolayer cultures (this protocol is for 1-liter cultures or multiples thereof).

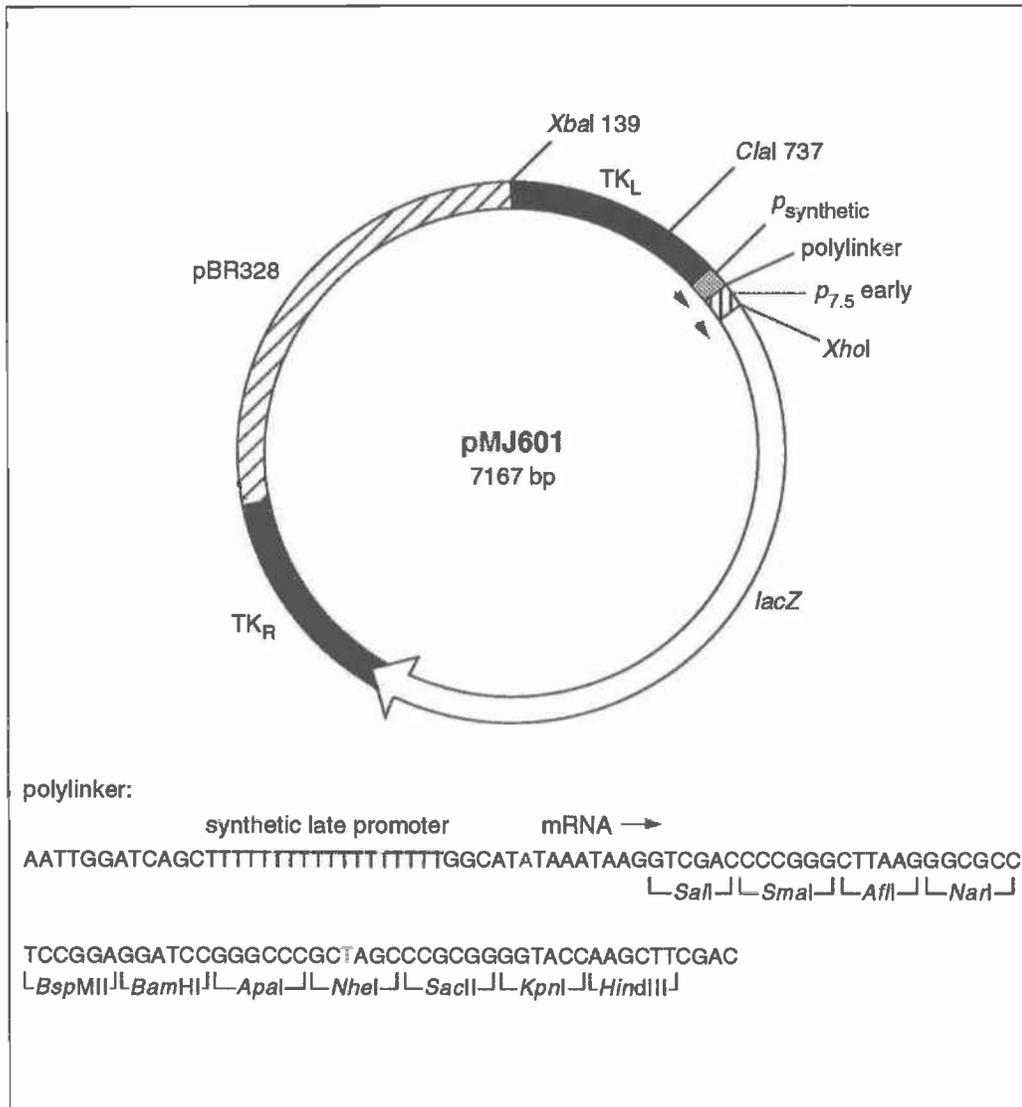

**Figure 16.17.4 pMJ601.** pMJ601 contains a very strong synthetic late promoter and a polylinker to be used as a multiple cloning site (Davison and Moss, 1990). The early portion of the promoter, *p*<sub>7.5</sub>, is used to regulate expression of the *E. coli lacZ* gene. The entire expression cassette is flanked by segments of the TK gene. TK selection and β-galactosidase screening can be used for isolation of recombinant virus plaques.

### **Additional Materials**

- Vaccinia virus stock (UNIT 16.16)
- 0.25 mg/ml trypsin (2× crystallized and salt-free; Worthington; filter sterilize and store at -20°C)
- HeLa S3 cells (UNIT 16.16)
- Complete spinner medium containing 5% horse serum (complete spinner medium-5; UNIT 16.16)
- 10 mM and 1 mM Tris·Cl, pH 9.0
- 95% ethanol
- 36% (w/v) sucrose solution in 10 mM Tris·Cl, pH 9.0
- 40%, 36%, 32%, 28%, and 24% (w/v) sucrose solutions in 1 mM Tris·Cl, pH 9.0, sterile
- Hemocytometer (UNIT 1.2)
- Vented spinner flasks (Bellco #1965 series and #A523-A59)
- Dounce homogenizer, glass and tight-fitting
- Probe sonicator (Ultrasonic processor VC-600, Sonics and Materials)
- Beckman SW-27 or SW-28 rotor and sterile centrifuge tubes (or equivalent)

### **Infect the cells**

1. Just prior to use, mix an equal volume of vaccinia virus stock and 0.25 mg/ml trypsin by vortexing vigorously. Incubate 30 min at 37°C, vortexing at 5- to 10-min intervals.

*If clumping of cell debris is still present after 30 min of trypsinization, the virus should be sonicated to disperse clumps and fully release virus. For details on sonication using a cup, see annotation to step 12.*

2. Count HeLa S3 cells using a hemacytometer.
3. Centrifuge  $5 \times 10^8$  cells 10 min rotor at  $1800 \times g$  (2500 rpm in an H-6000A), room temperature, and discard supernatant.
4. Resuspend cells in complete spinner medium-5 at  $2 \times 10^7$  cells/ml.
5. Add trypsinized virus (from step 1) at an MOI of 5 to 8 pfu/cell and stir 30 min at 37°C.
6. Transfer cells to a vented spinner flask containing 1 liter complete spinner medium-5 and stir 2 to 3 days at 37°C.
7. Centrifuge cells 5 min at  $1800 \times g$ , 5° to 10°C, and discard supernatant.
8. Resuspend cells in 14 ml of 10 mM Tris·Cl, pH 9.0. Keep samples on ice for the remainder of the protocol.

### **Lyse the cells**

9. Homogenize cell suspension with 30 to 40 strokes in a tight-fitting, glass Dounce homogenizer. Check for cell breakage by light microscopy.
10. Centrifuge 5 min at  $300 \times g$  (900 rpm in an H-6000A rotor), 5° to 10°C, to remove nuclei. Save the supernatant.
11. Resuspend cell pellet in 3 ml of 10 mM Tris·Cl, pH 9.0. Centrifuge 5 min at  $300 \times g$ , 5° to 10°C. Save the supernatant and pool with the supernatant from step 10.
12. Sonicate the lysate—keeping the lysate on ice the entire time—using a probe sonicator as follows: (a) sterilize the probe by dipping it in 95% ethanol and passing it through a flame; (b) let the probe cool; (c) remove the cap from the tube containing

the lysate, place the probe into the lysate, and sonicate at full power for 15 sec; (d) wait 15 sec and repeat sonication three to four times.

*If a probe sonicator is unavailable, sonication can be done in a cup. However, with this procedure, it is best to split the sample into 3-ml aliquots and sonicate each separately. To use a cup sonicator, fill the cup with ice-water (~50% ice). Place the tube containing the lysate in the ice-water, and sonicate at full power for 1 min. Repeat this three to four times, placing the lysate on ice for  $\geq 30$  sec between sonications. Because sonication melts the ice, it is necessary to replenish the ice in the cup.*

#### **Obtain purified virus**

13. Layer the sonicated lysate onto a cushion of 17 ml of 36% sucrose (in 10 mM Tris·Cl, pH 9.0) in a sterile SW-27 centrifuge tube. Centrifuge 80 min at  $32,900 \times g$  (13,500 rpm in an SW-27 rotor), 4°C. Aspirate and discard the supernatant.
14. Resuspend the viral pellet in 1 ml of 1 mM Tris·Cl, pH 9.0.
15. Sonicate once for 15 sec with a probe sonicator as in step 12.

*If a cup sonicator is used, sonicate 1 min.*

16. Prepare a sterile 24% to 40% continuous sucrose gradient in a sterile SW-27 centrifuge tube the day before needed by carefully layering 6.8 ml of each of the following sucrose solutions (in 1 mM Tris·Cl, pH 9.0) in the tube: 40%, 36%, 32%, 28%, and 24%. Let sit overnight in refrigerator.
17. Overlay the sucrose gradient with 1 ml sonicated viral pellet from step 15. Centrifuge 50 min at  $26,000 \times g$  (12,000 rpm in an SW-27 rotor), 4°C.
18. Observe the virus as a milky band in about the middle of the tube. Aspirate the sucrose above the band and discard. Carefully collect the virus band (~10 ml) with a sterile pipet and place in a sterile tube and save.
19. Collect aggregated virus from the pellet at the bottom of the sucrose gradient by aspirating the remaining sucrose from the tube. Resuspend the viral pellet by pipetting up and down in 1 ml of 1 mM Tris·Cl, pH 9.0.
20. Sonicate as in step 15.
21. Reband the virus as in steps 16 to 18 and pool band with band from step 18. Add 2 vol of 1 mM Tris·Cl, pH 9.0, and mix. Transfer to sterile SW-27 centrifuge tubes.

*The total volume should be ~60 ml, which is enough to fill two SW-27 centrifuge tubes. If less volume is obtained, fill the tubes with 1 mM Tris·Cl, pH 9.0.*

22. Centrifuge 60 min at  $32,900 \times g$ , 4°C, and aspirate and discard the supernatant.
23. Resuspend the virus pellets in 1 ml of 1 mM Tris·Cl, pH 9.0. Sonicate and divide into 200- to 250- $\mu$ l aliquots. Save one aliquot for step 24 and freeze remainder at -70°C.
24. On the unfrozen aliquot, estimate the amount of virus spectrophotometrically: one  $A_{260}$  unit is  $\sim 1.2 \times 10^{10}$  virus particles, which is  $\sim 2.5\text{--}5 \times 10^8$  pfu (value is approximate due to light scattering). Use this to determine the amount of virus needed in the support protocol for isolation of vaccinia virus DNA.
25. Titer the virus by sonicating 20 to 30 sec on ice, preparing 10-fold serial dilutions to  $10^{-10}$ , and infecting in duplicate confluent BS-C-1 cell monolayers in 6-well tissue culture dishes using the  $10^{-8}$ ,  $10^{-9}$ , and  $10^{-10}$  dilutions (UNIT 16.16).

## ISOLATION OF VACCINIA VIRUS DNA

## SUPPORT PROTOCOL

If vaccinia DNA is used in the transfection protocol, it is isolated after a proteinase K digestion and phenol extraction. The extracted DNA is precipitated and then dissolved in water. The DNA concentration is determined by measuring  $A_{260}$ .

### *Additional Materials*

Purified vaccinia virus (first support protocol)  
50 mM and 1 M Tris·Cl, pH 7.8  
10% sodium dodecyl sulfate (SDS)  
60% sucrose  
10 mg/ml proteinase K  
Phenol equilibrated with 50 mM Tris·Cl, pH 7.8 (UNIT 2.1)  
1:1 (vol/vol) phenol/chloroform  
1 M sodium acetate, pH 7.0  
100% and 95% ethanol

1. Measure purified vaccinia virus at  $A_{260}$  and bring 20  $A_{260}$  units of virus to 1.2 ml final volume with 50 mM Tris·Cl, pH 7.8. Avoid vortexing the DNA throughout this protocol.

*Because the vaccinia virus genome is large, care must be taken to avoid shearing (i.e., not vortexing) if full-length DNA (such as for restriction digestion analysis) is desired.*

2. Add the following to the vaccinia suspension (for 2 ml final volume):

0.1 ml 1 M Tris·Cl, pH 7.8  
0.1 ml 10% SDS  
0.2 ml 60% sucrose  
0.4 ml 10 mg/ml proteinase K.

Incubate 4 hr at 37°C.

3. Extract twice with phenol as follows: add an equal volume equilibrated phenol, mix *gently* by rocking the tube, centrifuge 10 min in an H-6000A rotor at 900 rpm ( $300 \times g$ ), room temperature, and save the aqueous phase using a pipet with the tip cut off.
4. Extract once with 1:1 phenol/chloroform as in step 3.
5. Add 1/10 vol of 1 M sodium acetate, pH 7.0, and 2.5 vol of 100% ethanol. Mix gently and cool several hours at  $-20^{\circ}\text{C}$ .
6. Microcentrifuge 10 min at top speed,  $4^{\circ}\text{C}$ . Aspirate and discard supernatant.
7. Wash pellet twice with 95% ethanol, air dry, and dissolve in 100  $\mu\text{l}$  water.
8. Prepare dilutions (using only a small amount of the total material) and measure  $A_{260}$  to determine DNA concentration (APPENDIX 3).

**SELECTION AND SCREENING OF RECOMBINANT VIRUS PLAQUES**

Two procedures involving guanine phosphoribosyltransferase (XGPRT) or thymidine kinase (TK) for selecting plaques that contain recombinant viruses are described (see commentary regarding choice of procedure). In addition,  $\beta$ -galactosidase screening can be used alone or in conjunction with TK selection to discriminate TK<sup>-</sup> recombinants from spontaneous TK<sup>-</sup> mutants. For each method, recombinant virus (obtained in the transfection basic protocol) is used to infect a monolayer culture of cells—for XGPRT selection, BS-C-1 cells are used because large plaques are obtained; for TK selection, it is necessary to use a cell line such as HuTK<sup>-</sup> 143B that is deficient in thymidine kinase. Molten agarose with medium containing the appropriate selective drugs is then pipetted onto the infected cell monolayer. Because of cell-to-cell spread of virus, each productively infected cell gives rise to a plaque. After two days, a second agarose overlay containing neutral red is placed on top of the first agarose overlay, whereupon neutral red is taken up by viable cells. In infected areas of the monolayer, the cells are rounded and dead, and thus appear as colorless plaques after neutral red staining. If  $\beta$ -galactosidase screening is used, the substrate Xgal is included in the second agarose overlay. Plaques containing infected cells that have expressed  $\beta$ -galactosidase turn blue; thus, blue (recombinant) plaques can be distinguished from clear (wild-type) plaques. A Pasteur pipet is used to aspirate infected cells from the plaques and the virus is released by freeze-thaw cycling and sonication. Several rounds of plaque purification are used to ensure the absence of residual wild-type virus.

*Materials*

- BS-C-1 confluent monolayer culture (UNIT 16.16)
- HuTK<sup>-</sup> 143B confluent monolayer culture (UNIT 16.16)
- Complete minimum essential medium containing 2.5% fetal calf serum (complete MEM-2.5, UNIT 16.16)
- 10 mg/ml mycophenolic acid (MPA; Calbiochem #475913) in 0.1 N NaOH (400 $\times$ ; store at  $-20^{\circ}\text{C}$ )
- 10 mg/ml xanthine in 0.1 N NaOH (40 $\times$ ; store at  $-20^{\circ}\text{C}$ )
- 10 mg/ml hypoxanthine in water (670 $\times$ ; store at  $-20^{\circ}\text{C}$ )
- Transfected cell lysate (first basic protocol)
- 2% LMP agarose in water, sterilized by autoclaving (GIBCO/BRL #5517UA)
- Complete 2 $\times$  plaque medium containing 5% FCS (complete 2 $\times$  plaque medium-5)
- 5 mg/ml BrdU in water (filter sterilize and store at  $-20^{\circ}\text{C}$ )
- 10 mg/ml neutral red in water
- 4% Xgal in dimethylformamide (optional; Table 1.4.2)
- Hemocytometer (UNIT 1.2)
- 6-well, 35-mm tissue culture dishes
- Humidified 37 $^{\circ}\text{C}$ , 5% CO<sub>2</sub> incubator
- 45 $^{\circ}\text{C}$  water bath
- Rubber bulb for Pasteur pipet
- Cotton-plugged Pasteur pipets, sterile

*Prepare the cells*

1. Trypsinize confluent monolayer culture and resuspend in appropriate complete medium as in UNIT 16.16, steps 4 to 7 of the first basic protocol.
  - a. For XGPRT selection, use BS-C-1 cells.
  - b. For TK selection, use HuTK<sup>-</sup> 143B cells.
2. Count cells using a hemacytometer.

3. Plate  $5 \times 10^5$  cells/well in a 6-well tissue culture dish (2 ml/well final). Place in a CO<sub>2</sub> incubator at 37°C and allow to reach confluency (this should take <24 hr).
4. Prepare cells as indicated below.
  - a. For XGPRT selection, preincubate monolayer for 12 to 24 hr in filter-sterilized complete MEM-2.5 containing:
    - $\frac{1}{400}$  vol 10 mg/ml MPA
    - $\frac{1}{40}$  vol 10 mg/ml xanthine
    - $\frac{1}{670}$  vol 10 mg/ml hypoxanthine.
  - b. For TK selection do not preincubate.

***Prepare the lysate and infect cells***

5. Trypsinize 100  $\mu$ l of transfected cell lysate as described for wild-type vaccinia virus in step 3 of the first basic protocol. Sonicate 20 to 30 sec on ice.
6. Make four 10-fold serial dilutions ( $10^{-1}$  to  $10^{-4}$ ; UNIT 1.11) of the trypsinized cell lysate in complete MEM-2.5 as indicated below.
  - a. For XGPRT selection, add MPA, xanthine, and hypoxanthine at the concentrations indicated in step 4a above.
  - b. For TK selection make no additions.
7. Aspirate medium from the cell monolayers (from step 3) and infect with 1.0 ml diluted lysate per well. Place 2 hr in a CO<sub>2</sub> incubator at 37°C, rocking at 30-min intervals.
 

*Use dilutions between  $10^{-2}$  and  $10^{-4}$ .*
8. Before the 2-hr infection is finished, melt 2% LMP agarose (1.5 ml  $\times$  number of wells) and place in a 45°C water bath to cool—be sure it cools to 45°C before using it to overlay cells. Prepare and warm to 45°C the necessary amount of selective plaque medium (1.5 ml  $\times$  number of wells) by making the following additions to complete 2 $\times$  plaque medium-5:
  - a. For XGPRT selection, include MPA, xanthine, and hypoxanthine at twice the concentrations indicated in step 4a (twice the concentration is necessary because the 2 $\times$  plaque medium will be mixed 1:1 with agarose); filter sterilize.
  - b. For TK selection, include  $\frac{1}{100}$  vol of 5 mg/ml BrdU.
9. Prepare appropriate selective agarose by mixing equal volumes of 2% LMP agarose and selective plaque medium from step 8a or 8b.
10. Aspirate the viral inoculum from cells (from step 7). Overlay each well with 3 ml appropriate selective agarose and allow to solidify at room temperature or 4°C. Place 2 days in a CO<sub>2</sub> incubator at 37°C.
11. Prepare the second agarose overlay by mixing an equal volume of 2% LMP agarose (1 ml  $\times$  number of wells, melted and cooled to 45°C) and 2 $\times$  plaque medium-5 (1 ml  $\times$  number of wells, warmed to 45°C) with  $\frac{1}{100}$  vol of 10 mg/ml neutral red. If  $\beta$ -galactosidase screening is to be used, add  $\frac{1}{120}$  vol of 4% Xgal to the agarose/ plaque medium. Overlay each well with 2 ml second agarose overlay, allow to solidify, and place overnight in a CO<sub>2</sub> incubator at 37°C.

*There is no need to add any FCS, glutamine, penicillin/streptomycin, or any selection drugs to this overlay medium.*

### **Obtain the plaques**

12. Add 0.5 ml complete MEM-2.5 to sterile microcentrifuge tubes. When incubation period is complete (step 11), pick well-separated plaques by squeezing the rubber bulb on a sterile, cotton-plugged Pasteur pipet and inserting the tip through the agarose to the plaque. Scrape the cell monolayer and aspirate the agarose plug into the pipet. Transfer to a tube containing 0.5 ml complete MEM-2.5. Repeat for six to twelve plaques, placing each in a separate tube.
13. Vortex, then carry out freeze-thaw cycling of the plaque isolates three times as described in step 10 of the first basic protocol.
14. Place tube containing virus into a cup sonicator containing ice-water and turn on full power for 20 to 30 sec (a probe sonicator dipped into a 50 ml plastic beaker also may be used; see step 12 of the first support protocol). Cool on ice after sonication.

*If TK selection only has been used, plaque isolates should be tested by DNA dot-blot hybridization (UNIT 16.18) or polymerase chain reaction (UNIT 16.18) because some plaques will contain spontaneous TK<sup>-</sup> mutations and not recombinant virus.*

### **Carry out several rounds of plaque purification**

15. Prepare monolayers of the appropriate cell line as described in steps 1 to 4; one 6-well dish is needed for each plaque isolate.
16. Make three 10-fold serial dilutions at  $10^{-1}$ ,  $10^{-2}$ , and  $10^{-3}$  of each of several plaque isolates as described in step 6.

*If XGPRT selection is used, cells must be preincubated with selective drugs and serial dilutions of the viral isolates must also contain selective drugs (step 4a).*

17. Aspirate medium from cell monolayers and infect two wells with 1.0 ml of each dilution of virus. Place 2 hr in a CO<sub>2</sub> incubator at 37°C, rocking by hand at 30-min intervals.
18. Repeat steps 8 to 14 for two or three rounds of plaque purification to ensure a clonally pure recombinant virus.

## **BASIC PROTOCOL**

### **AMPLIFICATION OF A PLAQUE**

A recombinant plaque isolate (obtained after the selection and screening protocol above) is amplified by infection of successively larger numbers of cells. Medium containing drugs for XGPRT or TK selection is usually used up to and including infection of cells in a 25-cm<sup>2</sup> flask. Freeze-thaw cycling is carried out to release the recombinant virus from the cells. The titer of the virus stock is determined as described in UNIT 16.16.

#### **Materials**

- Resuspended recombinant plaque (see second basic protocol)
- Confluent monolayer cultures of appropriate cells in both a 12-well, 22-mm tissue culture dish and a 25-cm<sup>2</sup> tissue culture flask (UNIT 16.16)
- Complete minimum essential medium containing 2.5% and 10% fetal calf serum (complete MEM-2.5 and -10; UNIT 16.16)
- Spinner culture of HeLa S3 cells (UNIT 16.16)
- Humidified 37°C, 5% CO<sub>2</sub> incubator
- Hemocytometer (UNIT 1.2)
- Sorvall H-6000A rotor (or equivalent)
- 150-cm<sup>2</sup> tissue culture flask

### ***Infect a monolayer culture of cells with a plaque***

1. Sonicate resuspended recombinant plaque 20 to 30 sec on ice as described in step 14 of the second basic protocol.
2. Infect appropriate confluent monolayer culture in 12-well dish with 250  $\mu$ l ( $1/2$ ) of each plaque isolate. Place 1 to 2 hr in a CO<sub>2</sub> incubator at 37°C, rocking at ~15-min intervals.

*If XGPRT selection is used, the monolayer culture is preincubated for 12 to 24 hr in complete MEM-2.5 containing MPA, xanthine, and hypoxanthine (step 4a of the second basic protocol). Infection should also be done in the presence of these drugs.*

3. Overlay with 1 ml complete MEM-2.5 containing the appropriate drugs as indicated in the previous basic protocol—for XGPRT selection, follow step 4a and for TK selection, use  $1/200$  vol of 5 mg/ml BrdU. Place 2 days in a CO<sub>2</sub> incubator at 37°C or until cytopathic effect (cell rounding) is obvious.
4. Scrape cells, transfer to microcentrifuge tube, and microcentrifuge 30 sec at top speed. Aspirate and discard medium.
5. Resuspend cells in 0.5 ml complete MEM-2.5 and carry out freeze-thaw cycle three times as described in step 10 of the first basic protocol.
6. Sonicate 20 to 30 sec on ice as described in step 14 of the second basic protocol.

### ***Scale-up the culture***

7. Dilute 0.25 ml lysate with 0.75 ml complete MEM-2.5 containing selective drugs (see steps 2 and 3). Infect appropriate confluent monolayer culture in a 25-cm<sup>2</sup> flask and place 30 min to 1 hr in a CO<sub>2</sub> incubator at 37°C.
8. Overlay with 4 ml complete MEM-2.5 containing the appropriate drugs. Incubate 2 days in a CO<sub>2</sub> incubator at 37°C or until cytopathic effect is obvious.
9. Scrape cells, transfer to 15-ml conical centrifuge tube and centrifuge 5 min at 1800  $\times$  g (2500 rpm in H-6000A rotor), 5° to 10°C. Resuspend cells and repeat freeze-thaw cycling and sonication as described in steps 5 and 6.
10. Count HeLa S3 cells from a spinner culture using a hemacytometer.
11. Centrifuge  $5 \times 10^7$  cells 5 min at 1800  $\times$  g, room temperature, and discard supernatant.
12. Resuspend cells in 25 ml complete MEM-10, dispense in one 150-cm<sup>2</sup> flask, and place overnight in a CO<sub>2</sub> incubator at 37°C (for infection the following day).
13. Remove medium from cells and replace with a mixture of 0.25 ml lysate and 1.75 ml complete MEM-2.5. Place 1 hr in a CO<sub>2</sub> incubator at 37°C, rocking the flask at 15- to 30-min intervals.
14. Overlay with 25 ml complete MEM-2.5 (selection is not required at this step) and incubate 3 days in a CO<sub>2</sub> incubator at 37°C.
15. Detach cells from the flask by shaking. Transfer to centrifuge tube by pipetting, centrifuge 5 min at 1800  $\times$  g, 5° to 10°C. Aspirate and discard supernatant.
16. Resuspend cells in 2 ml complete MEM-2.5 and carry out freeze-thaw cycling three times as described in step 10 of the first basic protocol.
17. Determine titer of the viral stock as described in UNIT 16.16. Freeze viral stock at -70°C.

## REAGENTS AND SOLUTIONS

### *Complete 2× plaque medium-5*

2× plaque medium (GIBCO/BRL #320-1017) containing:  
5% fetal calf serum (FCS)  
0.03% glutamine  
100 U/ml penicillin and 100 µg/ml streptomycin

### *Transfection buffer*

0.14 M NaCl  
5 mM KCl  
1 mM Na<sub>2</sub>HPO<sub>4</sub>·2H<sub>2</sub>O  
0.1% dextrose  
20 mM HEPES  
Adjust to pH 7.05 with 0.5 M NaOH and filter sterilize  
*The pH of this buffer is critical and should be between 7.0 and 7.1.*

## COMMENTARY

### Background Information

Plasmid-transfer vectors have three essential components: an expression cassette consisting of a natural or synthetic vaccinia promoter, restriction endonuclease sites for insertion of foreign genes, and flanking vaccinia virus DNA that determines the site of homologous recombination. An additional component may provide antibiotic selection or color screening. Various transfer vectors are listed in Table 16.17.1 and three are presented in detail in Figures 16.17.2 to 16.17.4.

Homologous recombination may occur in two steps. Initially, recombination may result from a single cross-over event, resulting in integration of the circular plasmid and the creation of a tandem duplication; however, this intermediate is highly unstable. A second recombination event then occurs between the tandem repeats, resolving the structure into a small circular DNA molecule and either a wild-type or recombinant viral genome.

Considerable attention has been devoted to promoters because they affect both the time and level of expression (UNIT 16.15). The most widely used promoter, *p*<sub>7.5</sub>, actually contains tandem late and early promoters (Cochran et al., 1985) and provides a moderate level of expression throughout infection. The name of this compound promoter was derived from the size of the 7.5-kDa polypeptide translated from mRNA that hybridized to the vaccinia gene. Considerably higher levels of expression are frequently obtained with *p*<sub>11</sub> or *p*<sub>CAE</sub>, late promoters derived from the vaccinia 11-kDa gene (Bertholet et al., 1985) and the cowpox A-type inclusion protein gene (Patel

et al., 1988), respectively. Another two-fold increase in expression may be achieved with the synthetic late promoter in pMJ601 and pMJ602 (Davison and Moss, 1990) or the synthetic early/late compound promoter in pSC59 and pSC65 (Table 16.17.1).

The ability to synthesize many different kinds of proteins, including those with transmembrane domains, is one advantage of the vaccinia virus expression system. Nevertheless, very high expression of certain genes might adversely effect virus replication. If difficulty is experienced in obtaining recombinant vaccinia with strong promoters, the weaker *p*<sub>7.5</sub> promoter or the vaccinia virus/bacteriophage T7 hybrid system should be tried. Another promising approach for regulating expression is the *E. coli lac* operator/repressor system (Fuerst et al., 1989).

Several different methods for selecting recombinant viruses are available. The widely used TK selection method is based on the insertional inactivation of the thymidine kinase gene (see description in UNIT 9.5). In the presence of active TK, added BrdU is phosphorylated and incorporated into viral DNA, where it causes lethal mutations. If TK<sup>-</sup> cells are used, then TK<sup>-</sup> virus will replicate normally in the presence of BrdU whereas TK<sup>+</sup> virus will not. Because the product of a single cross-over event is still TK<sup>+</sup>, only double cross-over events are selected. But, not all TK<sup>-</sup> viral plaques will be recombinants because spontaneous TK<sup>-</sup> mutants arise at a frequency of 1:10,000. Depending on the transfection efficiency, recombinants may comprise 10% to >90% of the TK<sup>-</sup> plaques.

$\beta$ -galactosidase screening is based on the co-insertion of the *E. coli lacZ* gene (*UNIT 1.4*) under the control of a separate vaccinia virus promoter into the vaccinia virus genome along with the gene of interest. If the TK gene is insertionally inactivated by such an event, recombinant viruses will be TK<sup>-</sup> and will make blue plaques on medium containing Xgal. This combination of  $\beta$ -galactosidase screening and TK selection will discriminate TK<sup>-</sup> recombinants from spontaneous TK<sup>-</sup> mutants. Two examples of insertion vectors that provide both TK<sup>-</sup> and  $\beta$ -galactosidase screening are shown in Figures 16.17.2 and 16.17.3.

XGPRT selection uses mycophenolic acid (MPA), an inhibitor of purine metabolism (see *UNIT 9.5*). Because MPA blocks the pathway for GMP synthesis, it interferes with the replication of vaccinia and severely reduces the size of vaccinia plaques. This effect can be overcome, however, by expression of the *E. coli gpt* gene in the presence of xanthine and hypoxanthine (i.e., the XGPRT gene product can use either of these as substrate for synthesis of GMP). Thus, co-expression of XGPRT provides a useful selection system. Unlike the TK<sup>-</sup> situation, the viral products arising from both single and double cross-over events will be selected. Therefore, it is important to do at least two and preferably three rounds of successive plaque isolations so that the single cross-over events will be resolved. An example of an insertion vector that allows MPA or TK selection is shown in Figure 16.17.4.

### Critical Parameters

During purification of vaccinia virus it is important to check the extract after Dounce homogenization to be sure that cells are broken; if they are not, repeat with more force for ten more strokes and check again. In addition, be sure to perform all steps on ice (this is particularly important when sonicating). Use sterile technique throughout.

Calcium phosphate transfections are described in detail in *UNIT 9.1*. As discussed there, obtaining a very fine precipitate of calcium phosphate and DNA is critical for efficient transfection. Several factors can influence the quality of the precipitate. First, the pH of the transfection buffer should be between 7.0 and 7.1. Second, if wild-type vaccinia DNA is used, it should be vortexed vigorously to shear the high-molecular-weight DNA prior to precipitation. Although co-precipitation of viral DNA with the insertion vector increases the efficiency of recombination, it is not required if a

selection procedure is used. Third, the CaCl<sub>2</sub> should be added slowly and mixed gently (not vortexed) only until full mixing is achieved. The tube should then be left undisturbed until the solution is layered on the cells.

During plaque purification and amplification of a new recombinant virus, it is important to maintain the appropriate selective pressure to prevent growth of any contaminating wild-type virus. After isolation, selection is not required. Check the purity of a recombinant virus by Southern blot analysis of a *Hind*III digest of the virus: the fragment into which the foreign gene has been cloned (the 5.1-kb *Hind*III J fragment for TK selection) should have increased by the size of the insert.

Freezing vaccinia stocks causes clumping of virus particles; thus, stocks should be trypsinized and/or sonicated after thawing. This is particularly important when plaque-purifying a virus, as each plaque should have arisen from a single virus. In addition, some lots of agarose contain contaminants that are toxic to cells (we have used low-melting-point agarose from GIBCO/BRL successfully).

If viral stocks are frozen at any step in the amplification, it is important to sonicate them again prior to infection. Be sure to save half of each stock at each step in case of contamination or failure at a succeeding step. See *UNIT 16.15* for precautions that need to be taken when working with vaccinia virus.

### Anticipated Results

Approximately  $1-5 \times 10^{10}$  pfu of purified virus should be obtained per liter ( $5 \times 10^8$ ) of HeLa cells.

Depending on the efficiency of the transfection, single, well-isolated plaques should be visible in cells infected with one of the recommended virus dilutions. With TK selection, from 10% to 90% of the plaques will contain recombinant virus. If  $\beta$ -galactosidase screening is also used, only blue recombinant virus plaques should be picked. With XGPRT selection, all plaques picked should contain recombinant virus. If the titer of recombinant virus is low, amplification can be achieved by a round of growth in the presence of MPA prior to plaquing (use the procedure described in amplification of a plaque).

Cytopathic effects should be clearly visible at each step of amplification except with final infection (infected HeLa cells do not exhibit clear cytopathic effects). The titer of the final crude stock should be  $1-2 \times 10^9$  pfu/ml.

Protein  
Expression

16.17.15

## Time Considerations

During purification of vaccinia virus, the viral amplification takes 2 to 3 days. After harvesting the infected cells, the entire purification can be done in 1 day. However, the protocol can be stopped after resuspension at step 12 or after collecting the band at step 16. The virus can be stored overnight at 4°C or at -70°C for longer periods.

The infection/transfection procedure for generation of recombinant virus takes ~6 hr and cells are harvested after 2 days.

Each round of selection and plaque purification takes 3 days, although little working time is required. Plaques can be picked and reinfections performed on the same day.

Amplification of a single plaque isolate to a small high-titer crude stock will take ~7 days. Large stocks should then be prepared as described in UNIT 16.17.

## Literature Cited

- Bertholet, C., Drillien, R., and Wittek, R. 1985. One hundred base pairs of 5' flanking sequence of a vaccinia virus late gene are sufficient to temporally regulate late transcription. *Proc. Natl. Acad. Sci. U.S.A.* 82:2096-2100.
- Boyle, D.B., Coupar, B.E.H., and Both, G.W. 1989. Multiple-cloning-site plasmids for the rapid construction of recombinant poxviruses. *Gene* 35:169-177.
- Chakrabarti, S., Brechling, K., and Moss, B. 1985. Vaccinia virus expression vector: Coexpression of beta-galactosidase provides visual screening of recombinant virus plaques. *Mol. Cell. Biol.* 5:3403-3409.
- Cochran, M.A., Puckett, C., and Moss, B. 1985. In vitro mutagenesis of the promoter region for a vaccinia virus gene: evidence for tandem early and late regulatory signals. *J. Virol.* 54:30-37.
- Coupar, B.E.H., Andrew, M.E., and Boyle, D.B. 1988. A general method for the construction of recombinant vaccinia viruses expressing multiple foreign genes. *Gene* 68:1-10.
- Davison, A.J. and Moss, B. 1990. New vaccinia virus recombination plasmids incorporating a synthetic late promoter for high level expression of foreign proteins. *Nucl. Acids Res.* 18:4285-4286.
- Earl, P., Koenig, S., and Moss, B. 1990. Biological and immunological properties of human immunodeficiency virus type 1 envelope glycoprotein: Analysis of proteins with truncations and deletions expressed by recombinant vaccinia viruses. *J. Virol.* 65:31-41.
- Falkner, F.G. and Moss, B. 1988. *Escherichia coli gpt* gene provides dominant selection for vaccinia virus open reading frame expression vectors. *J. Virol.* 62:1849-1854.
- Falkner, F. G., Chakrabarti, S., and Moss, B. 1987. pUVI: a new vaccinia virus insertion and expression vector. *Nucl. Acids Res.* 15:7192.
- Flexner, C., Hügin, A., and Moss, B. 1987. Prevention of vaccinia virus infection in immunodeficient nude mice by vector-directed IL-2 expression. *Nature (Lond.)* 330:259-262.
- Fuerst, T.R., Fernandez, M.P., and Moss, B. 1989. Transfer of the inducible *lac* repressor/operator system from *Escherichia coli* to a vaccinia virus expression vector. *Proc. Natl. Acad. Sci. U.S.A.* 86:2549-2553.
- Mackett, M., Smith, G.L., and Moss, B. 1984. General method for production and selection of infectious vaccinia virus recombinants expressing foreign genes. *J. Virol.* 49:857-864.
- Patel, D.D., Ray, C.A., Drucker, R.P., and Pickup, D.J. 1988. Apoxvirus-derived vector that directs high levels of expression of cloned genes in mammalian cells. *Proc. Natl. Acad. Sci. U.S.A.* 85:9431-9435.
- Perkus, M.E., Limbach, K., and Paoletti, E. 1989. Cloning and expression of foreign genes in vaccinia virus, using a host range selection system. *J. Virol.* 63:3829-3836.
- Rice, C.M., Franke, C.A., Strauss, J.H., and Hruby, D.E. 1985. Expression of Sindbis virus structural proteins via recombinant vaccinia virus: Synthesis, processing, and incorporation into mature Sindbis virions. *J. Virol.* 56:227-239.
- Shida, H., Tochikura, T., Sato, T., Konno, T., Hirayoshi, K., Seki, M., Ito, Y., Hatanaka, M., Hinuma, Y., Sugimoto, M., Takahashi-Nisimaki, F., Maruyama, T., Miki, K., Suzuki, K., Morita, M., Sashiyama, H., and Hayami, M. 1987. Effect of the recombinant vaccinia viruses that express HTLV-I envelope gene on HTLV-I infection. *EMBO J.* 6:3379-3384.
- Smith, G.L., Levin, J.Z., Palese, P., and Moss, B. 1987. Synthesis and cellular location of the ten influenza polypeptides individually expressed by recombinant vaccinia viruses. *Virology* 160:336-345.
- Tsao, H., Liu, G.-Q., Ruan, L., and Chu, C.-M. 1988. Construction and application of plasmids containing bidirectional promoters of vaccinia virus. *J. Virol.* 62:4832-4834.

## Key References

Mackett et al., 1984. See above.

Mackett, M., Smith, G.L., and Moss, B. 1985. The construction and characterisation of vaccinia virus recombinants expressing foreign genes. *In* DNA Cloning, Vol. II (D. Richwood and B.D. Hames, eds.) pp. 191-211. IRL Press, Oxford.

Piccini, A., Perkus, M.E., and Paoletti, E. 1987. Vaccinia virus as an expression vector. *Methods Enzymol.* 153:545-563.

---

Contributed by Patricia L. Earl and  
Bernard Moss  
National Institute of Allergy  
and Infectious Diseases  
Bethesda, Maryland

# Characterization of Recombinant Vaccinia Viruses and Their Products

UNIT 16.18

After a recombinant virus is made, its DNA and protein products can be analyzed in several ways. Identification of the recombinant virus can be carried out by dot-blot analysis (first basic protocol), with verification of correct insertion of the DNA by Southern blotting (second basic protocol). Alternatively, vaccinia DNA can be detected by PCR methodology (alternate protocol). If an early promoter is used, the size of the RNA transcript can be determined by northern blotting (third basic protocol). Finally, when antibodies are available, protein expression can be analyzed by immunological methods such as immunoblotting, western blotting, and/or immunoprecipitation (fourth, fifth, and sixth basic protocols).

**CAUTION:** Proceed carefully and follow biosafety level 2 (BL-2) practices when working with vaccinia virus (see UNIT 16.15 for safety guidelines).

**NOTE:** Carry out all procedures for growth of vaccinia virus using sterile technique in a tissue culture hood.

## DETECTION OF VACCINIA DNA USING DOT-BLOT HYBRIDIZATION

**BASIC  
PROTOCOL**

The presence of recombinant virus in isolated plaques can be confirmed by amplifying the virus, blotting the DNA onto a nitrocellulose membrane, and hybridizing with a radioactively labeled DNA probe (followed by detection on X-ray film). A dot-blot apparatus is used for blotting DNA onto the nitrocellulose membrane. This apparatus contains a grid of wells into which the samples are loaded. When suction is applied, the liquid passes through and the DNA remains on the nitrocellulose membrane.

### Materials

- Confluent BS-C-1 or HuTK<sup>-</sup> 143B cell monolayer (UNIT 16.16)
- Phosphate-buffered saline (PBS; APPENDIX 2)
- Trypsin/EDTA (0.25%:0.02%; Quality Biological #18-112-1), 37°C
- Complete minimum essential medium containing 10%, 2.5%, and 5% fetal calf serum (complete MEM-10, -2.5, and -5 UNIT 16.16), without and with selective drugs (UNIT 16.17)
- Complete MEM containing 10% FCS and 25 µg/ml 5-bromodeoxyuridine (complete MEM-10/BrdU; UNIT 16.16)
- Recombinant virus plaques (UNIT 16.17)
- 10 mg/ml mycophenolic acid (MPA; Calbiochem #475913) in 1 N NaOH (400×; store at -20°C)
- 10 mg/ml xanthine in 0.1 N NaOH (40×; store at -20°C)
- 10 mg/ml hypoxanthine in water (670×; store at -20°C)
- 5 mg/ml BrdU in water (filter sterilize and store at -20°C)
- 0.5 N NaOH
- 1 M Tris·Cl, pH 7.5 (APPENDIX 2)
- 2× SSC (APPENDIX 2)
- Hemacytometer (UNIT 1.2)
- 24-well, 16-mm tissue culture dishes
- Humidified 37°C, 5% CO<sub>2</sub> incubator
- Nitrocellulose membrane
- Dot-blot apparatus
- Whatman 3MM filter paper
- Additional reagents and equipment for Southern hybridization (UNIT 2.9)

**Protein  
Expression**

**16.18.1**

1. Aspirate medium from a confluent cell monolayer.
  - a. For XGPRT selection, use BS-C-1 cells.
  - b. For TK selection, use HuTK<sup>-</sup> 143B cells.
2. Wash cells once with PBS or trypsin/EDTA to remove the remaining serum.
3. Overlay cells with 37°C trypsin/EDTA using a volume that is just enough to cover the monolayer (1.5 ml for a 150-cm<sup>2</sup> flask). Allow to sit ~30 sec (the cells should become detached). Shake to detach cells completely.
4. Add 8.5 ml medium (see below). Pipet the cell suspension up and down several times to disrupt clumps.
  - a. For BS-C-1 cells, use complete MEM-10.
  - b. For HuTK<sup>-</sup> 143B cells, use complete MEM-10/BrdU.
5. Count cells using a hemacytometer.
6. Plate  $1.25 \times 10^5$  cells/well in 24-well tissue culture dishes (0.5 ml/well final). Place in a CO<sub>2</sub> incubator at 37°C and allow to reach confluency (this should take <24 hr).
7. Place tube containing virus into a cup sonicator containing a ice-water mixture and sonicate at full power for 20 to 30 sec.
 

*A probe sonicator dipped into a 50-ml plastic beaker may also be used.*
8. Aspirate medium and infect each well with one recombinant virus plaque, using half the volume in which each plaque is suspended. Place 1 to 2 hr in a CO<sub>2</sub> incubator at 37°C, rocking at 15- to 30-min intervals.
9. Overlay with 1 ml complete MEM-2.5 to which appropriate selection drugs have been added. Place in a CO<sub>2</sub> incubator at 37°C until cytopathic effect (cell rounding) is evident (usually 24 to 48 hr).
  - a. For XGPRT selection, add  $1/400$  vol of 10 mg/ml MPA,  $1/40$  vol of 10 mg/ml xanthine, and  $1/670$  vol of 10 mg/ml hypoxanthine.
  - b. For TK selection, add  $1/200$  vol of 5 mg/ml 5-BrdU.
10. Scrape cells and transfer to a microcentrifuge tube. Microcentrifuge 30 sec at top speed, then aspirate and discard medium. Resuspend cell pellet in 200 µl PBS.
 

*Cells in a 24-well dish can be scraped using the plunger of a 1-ml syringe.*
11. Lyse the cell suspension by freeze-thaw cycling as follows: freeze in dry ice/ethanol, thaw in a 37°C water bath, and vortex. Carry out the freeze-thaw cycling a total of three times.
12. Place tube containing virus into a cup sonicator containing a ice-water mixture and sonicate at full power for 20 to 30 sec.
 

*A probe sonicator dipped into a 50-ml plastic beaker may also be used.*
13. Cut nitrocellulose membrane to the appropriate size to fit in the dot-blot apparatus. Wet the membrane by immersing it in water and place in the apparatus. Add 20 to 100 µl cell lysate (from step 12) to each well. Draw the liquid through the membrane by applying suction and then remove the nitrocellulose from the apparatus.
14. Cut six pieces of Whatman 3MM filter paper so they are larger than the size of the nitrocellulose membrane. Soak one piece of 3MM paper with 0.5 N NaOH. Lay the nitrocellulose membrane on top of the wet 3MM paper and let sit for 1 min. Remove membrane and place it on a separate piece of dry 3MM paper for 1 min. Repeat this

procedure two times using the same 3MM paper.

*Forceps should be used to transfer the membrane.*

15. Repeat step 14 with Whatman 3MM paper soaked in 1 M Tris·Cl, pH 7.5 (three times per membrane).
16. Repeat step 14 with 3MM Whatman paper soaked in 2× SSC (three times per membrane).
17. Bake membrane 2 hr at 80°C.  
*Baking fixes the DNA to the filter.*
18. Proceed with DNA hybridization as described in *UNIT 2.9*, steps 18 to 25 of the protocol using nitrocellulose membranes.

## DETECTION OF VACCINIA DNA USING SOUTHERN BLOT HYBRIDIZATION

**BASIC  
PROTOCOL**

Historically, vaccinia virus DNA has been characterized by its *Hind*III restriction endonuclease digestion pattern. The TK gene, into which most foreign genes are inserted in recombinant viruses, is located in the 5.1-kbp *Hind*III J fragment. Thus in a recombinant virus, if the inserted gene has no *Hind*III sites, this fragment should be increased in size. The 5.1-kbp *Hind*III J fragment should be absent, indicating lack of contamination with wild-type vaccinia virus. Southern blot analysis can be done with DNA from purified virus (*UNIT 16.17*) or, more easily, from a crude lysate of infected cells as described below.

### *Materials*

- Confluent BS-C-1 cell monolayer (*UNIT 16.16*)
- Complete minimum essential medium containing 10% and 5% fetal calf serum (complete MEM-10 and -5; *UNIT 16.16*)
- Recombinant vaccinia virus stock (*UNIT 16.16*)
- 0.25 mg/ml trypsin (2× crystallized and salt-free; Worthington; filter sterilize and store at -20°C)
- Phosphate-buffered saline (PBS; *APPENDIX 2*)
- Low-salt buffer
- 20 mg/ml proteinase K
- Buffered phenol (*UNIT 2.1*)
- 1:1 phenol/chloroform
- 3 M sodium acetate, pH 6.0
- 95% and 70% ethanol, ice-cold
- TE buffer (10 mM Tris·Cl, pH 7.8/1 mM EDTA)
- Hind*III restriction endonuclease (*UNIT 3.1*)
- Hemocytometer (*UNIT 1.2*)
- 12-well tissue culture dishes
- Humidified 37°C, 5% CO<sub>2</sub> incubator
- Additional reagents and equipment for Southern hybridization (*UNIT 2.9*)

1. Repeat steps 1 to 5 of the first basic protocol using a confluent BS-C-1 cell monolayer.
2. Plate  $2.5 \times 10^5$  cells/well in 12-well tissue culture dishes (1 ml/well final). Place in a CO<sub>2</sub> incubator at 37°C and allow to reach confluency (this should take <24 hr).

**Protein  
Expression**

**16.18.3**

3. Just prior to use, mix an equal volume of recombinant vaccinia virus stock and 0.25 mg/ml trypsin, and vortex vigorously. Incubate 30 min in a 37°C water bath, vortexing at 5- to 10-min intervals during the incubation.

*Virus stocks are usually at a titer of  $\sim 2 \times 10^9$  pfu/ml but may be significantly lower depending on the source.*

*Vortexing usually breaks up any clumps. However, if there are still clumps, chill to 0°C and sonicate 30 sec on ice. Sonication can be repeated several times but the sample should be allowed to cool on ice between sonications.*

4. Aspirate medium and infect with an MOI of 10 to 20 pfu/cell in 250 µl complete MEM-5. Place 1 to 2 hr in a CO<sub>2</sub> incubator at 37°C, rocking at ~30-min intervals.
5. Overlay with 1 ml complete MEM-5. Place ~24 hr in a CO<sub>2</sub> incubator at 37°C.
6. Scrape cells and transfer to a microcentrifuge tube. Microcentrifuge 3 min at top speed, room temperature. Aspirate and discard supernatant.

*The plunger of a 1-ml syringe can be used to scrape cells.*
7. Resuspend pellet in 50 µl PBS and vortex.
8. Add 300 µl low-salt buffer and 10 µl of 20 mg/ml proteinase K to a microcentrifuge tube. Add cell suspension to this same tube. Vortex and incubate 5 hr to overnight at 37°C.
9. Extract once with an equal volume of buffered phenol and once with an equal volume of 1:1 phenol/chloroform (UNIT 2.1).

*If the solution is viscous after phenol extraction, pass it through a 25-G needle to shear DNA and reduce viscosity.*
10. Add 3 M sodium acetate, pH 6.0, to 0.3 M final and 2.5 vol of 95% ethanol. Place 30 min on dry ice or overnight at -20°C.
11. Microcentrifuge 10 min at top speed, 4°C. Aspirate and discard supernatant.
12. Wash pellet with ice-cold 70% ethanol and air dry.
13. Dissolve pellet in 100 µl TE buffer.
14. Digest 15 µl of DNA with *Hind*III and analyze by Southern hybridization.

#### **ALTERNATE PROTOCOL**

#### **DETECTION OF VACCINIA DNA USING PCR**

An alternate method of identifying recombinant virus in isolated plaques is to use the polymerase chain reaction (PCR) as indicated below.

##### *Additional Materials*

1 mM Tris-Cl, pH 9.0 (APPENDIX 2)

1. Resuspend recombinant virus plaques in 100 µl of 1 mM Tris-Cl, pH 9.0.
2. Carry out three rounds of freeze-thaw cycling and 30 sec of sonication as in steps 11 and 12 of the first basic protocol.
3. Extract DNA from 30 µl as described in the support protocol for isolation of vaccinia DNA in UNIT 16.17 (Zhang and Moss, 1991).
4. Carry out PCR for 50 cycles as described in UNIT 15.1.

## DETECTION OF VACCINIA RNA USING NORTHERN HYBRIDIZATION

Northern blotting is useful for analysis of transcripts directed by vaccinia virus early promoters. Infections are performed in the presence of cycloheximide to inhibit protein synthesis and enhance expression of early genes. Northern blotting is not useful for transcripts made by vaccinia virus late promoters since these yield RNAs that are long and heterogeneous in size. For products of late promoters, the correct RNA 5' ends can be determined by S1 nuclease protection (UNIT 4.6) or primer extension (UNIT 4.8). If these methods are used, it is important to note that late mRNAs typically have a nontranscribed poly(A) leader of ~35 nucleotides (UNIT 16.15).

*Materials*

Confluent BS-C-1 or CV-1 cell monolayer (UNIT 16.16)  
Complete minimum essential medium containing 10% fetal calf serum (complete MEM-10; UNIT 16.16)  
Complete Dulbeccos minimum essential medium containing 10% FCS (complete DMEM-10; UNIT 16.16)  
Complete MEM-5 (UNIT 16.16) containing 100 µg/ml cycloheximide (complete MEM-5/cycloheximide)  
Recombinant virus stock (UNIT 16.16)  
Phosphate-buffered saline (PBS; APPENDIX 2), ice-cold  
Northern lysis buffer  
Buffered phenol (UNIT 2.1)  
Chloroform  
3 M sodium acetate, pH 6.0  
95% ethanol  
RNA buffer  
1 U/µl DNase I (RQ1, Promega #M6101; UNIT 3.12)  
Hemocytometer (UNIT 1.2)  
100-mm tissue culture dish  
Humidified 37°C, 5% CO<sub>2</sub> incubator  
Cell scraper, sterile  
Sorvall H-6000A rotor (or equivalent)  
Additional reagents and equipment for northern hybridization (UNIT 4.9)

1. Repeat steps 1 to 5 of the first basic protocol using a confluent BS-C-1 or CV-1 cell monolayer.
  - a. For BS-C-1 cells, use complete MEM-10.
  - b. For CV-1 cells, use complete DMEM-10.
2. Plate  $3 \times 10^6$  cells/100-mm-diameter dish in 5 ml final. Place in a CO<sub>2</sub> incubator at 37°C and allow to reach confluency (this should take <24 hr).
3. Remove medium from confluent cell monolayer and overlay with complete MEM-5/cycloheximide. Incubate 10 min in a CO<sub>2</sub> incubator at 37°C.
4. Repeat step 3 of the second basic protocol.
5. Aspirate medium and infect monolayer culture at an MOI of 10 pfu/cell in 2 ml complete MEM-5/cycloheximide. Place 1 hr in a CO<sub>2</sub> incubator at 37°C, rocking at 15-min intervals.

*If purified virus is used, sonicate 30 sec on ice prior to use (see step 12, first basic protocol).*

6. Overlay with 8 ml complete MEM-5/cycloheximide and incubate 4 hr in a CO<sub>2</sub> incubator at 37°C.
7. Place dish on ice. Aspirate medium, overlay with ice-cold PBS, aspirate, and overlay with 5 ml ice-cold PBS.
8. Scrape cells with a sterile cell scraper and transfer to a centrifuge tube. Rinse plate with an additional 2 ml ice-cold PBS and add to centrifuge tube containing the scraped cells. Keep on ice during scraping, centrifugation, and lysis.
9. Centrifuge 3 min in an H-6000A rotor at 1500 rpm (650 × g), 4°C. Aspirate and discard supernatant.
10. Dissolve pellet in 1.5 ml northern lysis buffer by vortexing. Let sit 5 min on ice and vortex again.
11. Centrifuge 7 min at 650 × g, 4°C, and save supernatant.
12. Split supernatant into two microcentrifuge tubes. Extract once with buffered phenol and once with chloroform (UNIT 2.1).
13. Add 3 M sodium acetate, pH 6.0, to 0.3 M final and 4 vol of 95% ethanol. Place 30 min on dry ice or overnight at -20°C.
14. Microcentrifuge 10 min at top speed, 4°C. Aspirate and discard supernatant.
15. Dissolve pellet in 0.3 ml RNA buffer. Add 1.5 μl of 1 U/μl DNase I and incubate 10 min at 37°C.
16. Extract once with buffered phenol and once with chloroform (UNIT 2.1).
17. Add 3 M sodium acetate, pH 6.0, to 0.3 M final and 2.5 vol of 95% ethanol. Place 30 min on dry ice or overnight at -20°C.
18. Microcentrifuge 10 min at top speed, 4°C, and discard supernatant.
19. Air dry pellet and resuspend in 20 μl RNA buffer.
20. Proceed with northern hybridization (UNIT 4.9).

**BASIC  
PROTOCOL**

**DETECTION OF EXPRESSED PROTEIN IN PLAQUES USING  
DOT-BLOT IMMUNOBLOTTING**

This protocol is usually used as an alternative to DNA dot-blot hybridization for checking plaques. Infected cell lysates are spotted onto a nitrocellulose membrane as in the DNA dot-blot protocol. The membrane is then incubated with an antibody that recognizes the expressed foreign gene product. <sup>125</sup>I-labeled protein A is used to detect the bound antibody. The membrane is then exposed to X-ray film.

*Materials*

PBS containing 0.5% Tween-20 (PBS/Tween) with and without 4% BSA  
 Antibody to foreign protein  
 [<sup>125</sup>I]protein A

1. Repeat steps 1 to 13 of the first basic protocol.
2. Soak membrane in PBS/Tween containing 4% BSA for ~30 min. Wash once with PBS/Tween.

*Washing is done by pouring liquid off and replacing it.*

3. Dilute antibody to foreign protein 1:50 to 1:5000 in a minimal volume of PBS/Tween. Incubate membrane in this solution  $\geq 1$  hr at room temperature.
4. Wash approximately five times with an excess volume of PBS/Tween.
5. Incubate membrane in a minimal volume of PBS/Tween containing 1  $\mu$ Ci of [ $^{125}$ I]protein A for 30 min.
6. Wash membrane approximately five times with an excess volume of PBS/Tween.
7. Wrap membrane in plastic wrap and expose to X-ray film.

## DETECTION OF EXPRESSED PROTEIN USING IMMUNOBLOTTING

After a recombinant virus has been plaque purified and amplified, immunoblotting can be used to determine if the protein is of the expected size and whether or not it is secreted from infected cells.

### Materials

- Confluent BS-C-1 cell monolayer (UNIT 16.16)
- Complete minimum essential medium containing 5% fetal calf serum (complete MEM-5; UNIT 16.16)
- Cell lysis buffer
- Recombinant virus stock
- 5 $\times$  SDS/sample buffer (UNIT 10.2)
- Hemocytometer (UNIT 1.2)
- 6-well, 35-mm tissue culture dishes
- Sorvall H-6000A rotor (or equivalent)
- Additional reagents and equipment for immunoblotting (UNIT 10.8)

1. Repeat steps 1 to 5 of the first basic protocol using a confluent BS-C-1 cell monolayer.
2. Plate  $5 \times 10^5$  cells/well in a 6-well tissue culture dish (2 ml/well final). Place in a CO<sub>2</sub> incubator at 37°C and allow to reach confluency (this should take <24 hr).
3. Repeat step 3 of the second basic protocol.
4. Aspirate medium and infect monolayer culture at an MOI of 10 to 30 pfu/cell in 1 ml final volume complete MEM-5. Place 1 to 2 hr in a CO<sub>2</sub> incubator at 37°C, rocking at ~30-min intervals.

*If purified virus is used, sonicate 30 sec on ice prior to use (see step 12, first basic protocol).*

5. Overlay with 2 ml complete MEM-5 and return 24 to 48 hr to CO<sub>2</sub> incubator at 37°C.

*Secretory proteins can also be analyzed. However, it is important to infect and overlay the cells with medium that does not require the addition of serum or to use only 1% serum since a high concentration of serum proteins interferes with gel analysis. Concentrate the medium by spinning in a Centricon 10 microconcentrator (Amicon) until the volume is reduced ~5-fold. Alternatively, proteins can be precipitated from the medium by trichloroacetic acid (TCA) precipitation as follows: add an equal volume of 20% TCA, place 1 hr on ice, microcentrifuge 10 min at top speed, aspirate supernatant, wash the pellet with 70% ethanol, dry, and dissolve in 1 $\times$  SDS/sample buffer.*

6. Scrape cells and transfer to centrifuge tube. Centrifuge 5 min in an H-6000A rotor at 2500 rpm (1800  $\times$  g), 5° to 10°C. Aspirate and discard supernatant.

**BASIC  
PROTOCOL**

**Protein  
Expression**

**16.18.7**

7. Resuspend cell pellet in 200  $\mu$ l cell lysis buffer and transfer to microcentrifuge tube. Vortex and let sit 10 min on ice.  
*Cell lysis buffer contains nonionic detergent only. This may not be sufficient for extraction of some proteins. SDS-containing buffer (UNIT 16.11) may be necessary.*
8. Microcentrifuge 10 min at top speed, 4°C. Separate supernatant (cytoplasm) and pellet (nuclei).
9. To 20  $\mu$ l supernatant, add 5  $\mu$ l of 5 $\times$  SDS/sample buffer and heat 5 min at 95°C. Dissolve pellet in 200  $\mu$ l of 1 $\times$  SDS/sample buffer and heat 5 min at 95°C.
10. Proceed with protocol for immunoblotting (UNIT 10.8).

### **DETECTION OF EXPRESSED PROTEIN USING IMMUNOPRECIPITATION**

When strong late promoters are used, the expressed recombinant protein can usually be detected by polyacrylamide gel electrophoresis following labeling with radioactive amino acids. Immunoprecipitation of the labeled proteins can be used to increase sensitivity and specificity when early or late promoters are used.

#### *Materials*

Complete minimum essential medium containing 5% fetal calf serum (complete MEM-5; UNIT 16.16)

Complete methionine- or cysteine-free MEM-5 containing dialyzed FCS  
1000 Ci/mmol [<sup>35</sup>S]methionine (e.g., Amersham #SJ1515) or 600 Ci/mmol  
[<sup>35</sup>S]cysteine (e.g., Amersham #SJ232)

Phosphate-buffered saline (PBS; APPENDIX 2)

Cell lysis buffer

Additional reagents and equipment for immunoprecipitation (UNIT 10.16)

1. Follow steps 1 to 4 of the immunoblotting basic protocol.
2. Overlay with 2 ml complete MEM-5 and return to incubator.

*The time after infection at which metabolic labeling is performed will depend upon which promoter is used to express the gene of interest. If an early promoter only is used, labeling should be done between 1 and 6 hr postinfection. If a late promoter is used, labeling should be done between 4 and 20 hr postinfection. With a compound early/late promoter, either time may be used.*

3. At the appropriate time after infection, aspirate medium and replace with 1 ml complete methionine- or cysteine-free MEM-5 (dialyzed) containing 25 to 50  $\mu$ Ci of 1000 Ci/mmol [<sup>35</sup>S]methionine or 600 Ci/mmol [<sup>35</sup>S]cysteine and 35  $\mu$ l complete MEM-5. Place 2 to 3 hr to overnight in a CO<sub>2</sub> incubator at 37°C.
4. Add 0.15 ml complete MEM-5 as chase. Return 1 hr to CO<sub>2</sub> incubator at 37°C.
5. Remove medium and save if expressed protein is secretory.  
*If the medium is to be analyzed, remove any free cells by microcentrifuging 3 min.*
6. Overlay cells with 1 ml PBS, scrape, and transfer to microcentrifuge tube. Microcentrifuge 3 min at top speed, room temperature. Aspirate and discard supernatant.
7. Suspend cells in 200  $\mu$ l cell lysis buffer. Vortex and place 10 min on ice.
8. Microcentrifuge 10 min at top speed, 4°C. Remove supernatant and proceed with immunoprecipitation beginning at the supernatant step(s) in UNIT 10.16.

## REAGENTS AND SOLUTIONS

### *Cell lysis buffer*

100 mM Tris·Cl, pH 8.0  
100 mM NaCl  
0.5% Triton X-100 or NP-40

Add PMSF (or other protease inhibitors; optional) from a 100× stock to 0.2 mM final just before use. Store 100× stock at -20°C.

### *Low-salt buffer*

20 mM Tris·Cl, pH 8.0  
10 mM EDTA  
0.75% sodium dodecyl sulfate (SDS)

### *Northern lysis buffer*

10 mM Tris·Cl, pH 7.6  
10 mM NaCl  
1.5 mM MgCl<sub>2</sub>  
5 mM EDTA  
0.5% Nonidet P-40 (NP-40)

### *RNA buffer*

40 mM Tris·Cl, pH 7.6  
10 mM NaCl  
6 mM MgCl<sub>2</sub>

## COMMENTARY

### **Background Information**

Several different methods of characterizing recombinant vaccinia viruses are available. Each is suitable at a different time during isolation and characterization of a recombinant virus. During plaque purification of a new virus, DNA dot-blot hybridization, PCR, or immunoblotting of individual plaque isolates is a quick and easy way of determining which plaque contains the foreign gene. This is particularly important if TK selection only is used, since not all plaques will contain recombinant virus.

After an isolate has been plaque purified several times and amplified, analysis of the DNA by Southern blotting can be used to determine whether or not a pure isolate has been obtained. Restriction endonuclease digestion of vaccinia DNA with *Hind*III gives a specific pattern. The *Hind*III fragment into which the foreign gene has been inserted should be increased in size by the size of the foreign gene (unless the latter contains a *Hind*III site). The TK gene, which is the most commonly used region for insertion of a foreign gene, is located in the 5.1 kbp *Hind*III J fragment.

Western blotting or radioimmunoprecipitation using an antibody specific for the gene of

interest will determine whether the correct gene product is made. Analysis of the extracellular medium will show whether the protein is secreted. If a nuclear localization signal is present, the protein may be translocated into the nucleus. In this case, the nuclei should also be analyzed (see step 8 of the western blotting basic protocol).

For large-scale production of protein, HeLa cell suspension cultures may be infected as described in the support protocol for purification of vaccinia virus in *UNIT 16.17*, and harvested after 48 to 72 hr. Alternatively, microcarrier cultures of Vero cells may be used (Barrett et al., 1989).

### **Critical Parameters**

In all protocols for identifying plaques containing recombinant virus, it is important to include positive and negative controls. For DNA dot-blot hybridization, the plasmid used for transfection is an appropriate positive control, while cells infected with wild-type vaccinia virus can serve as a negative control. For immunoblotting, an extract of cells known to express the foreign gene can be used (e.g., influenza virus-infected cells could be used as a positive control for analysis of a recombinant vaccinia virus expressing an influenza

gene). Cells infected with wild-type vaccinia virus can be used as a negative control.

Solutions used for northern hybridizations must not be contaminated with RNase. Reagents, tubes, and pipets should be autoclaved or heat-sterilized, and gloves should be worn during RNA preparation and while handling samples (see introduction to Section I of Chapter 4 for guidelines concerning avoidance of contamination in RNA work).

If lysates for western blotting are frozen prior to gel analysis, it is important to microcentrifuge 5 min at top speed to pellet subcellular debris before removing a sample of the supernatant for gel electrophoresis.

In planning an immunoprecipitation, check the amino acid composition of the expressed protein for numbers of methionine and cysteine residues and then label with the appropriate amino acid(s).

### Anticipated Results

The Southern blotting protocol in this unit is a quicker, easier method than that from *UNIT 2.9*. Since the most common region used for insertion of foreign genes into vaccinia virus is the TK locus within the 5.1-kbp *HindIII* J fragment, the size of this fragment should be larger in a recombinant virus (if there is no *HindIII* site within the inserted DNA). Hybridization of a second blot or rehybridization of the original blot with <sup>32</sup>P-labeled vaccinia virus DNA will show the overall *HindIII* restriction digestion pattern. The 5.1-kbp *HindIII* J fragment should be absent, indicating that the virus isolate does not contain any contaminating wild-type recombinant virus. A control of wild-type *HindIII*-digested vaccinia DNA is helpful for a comparison to the original restriction endonuclease pattern.

Visualization of protein bands from a western blotting procedure is usually accomplished with an X-ray film exposure of 1 to 24 hr. Additional time may be required if the antibody recognition is poor; if this is the case, cells can be lysed in a smaller volume, allowing more lysate to be analyzed in one

lane. Additional incubation time or a lower dilution of antibody may also help to intensify the signal. A western blot that has been exposed to X-ray film but has not been completely dried can be reincubated with the same antibody (if the original antibody concentration was too low) or with a different antibody. Negative and positive controls should be included to help identify specific protein bands.

For an immunoprecipitation, the gel exposure time will depend on several factors, including the amount of label incorporated into the protein and the affinity of the antibody for the protein. It may be necessary to optimize results by adjusting the amount of labeled amino acid used, the amount of antibody used, or the time of incubation of the lysate with the antibody.

### Time Considerations

The DNA dot-blot hybridization and immunoblotting protocols require 2 days for amplification of the virus. An additional day is necessary for hybridization and washing. Time of exposure to X-ray film for both protocols varies depending upon the hybridization probe or antibody used.

Northern hybridization will take 3 to 4 days to complete. Western blotting and immunoprecipitation will each take 2 to 3 days.

### Literature Cited

- Barrett, N., Mitterer, A., Mundt, W., Eibl, J., Eibl, M., Gallo, R.C., Moss, B., and Dörner, F. 1989. Large-scale production and purification of a vaccinia recombinant-derived HIV-1 gp 160 and analysis of its immunogenicity. *AIDS Res. Hum. Retroviruses* 5:159-171.
- Zhang, Y., and Moss, B. 1991. Inducer-dependent conditional-lethal mutant animal viruses. *Proc. Natl. Acad. Sci. U.S.A.* 88:1511-1515.

---

Contributed by Patricia L. Earl  
and Bernard Moss  
National Institute of Allergy  
and Infectious Diseases  
Bethesda, Maryland

# Gene Expression Using the Vaccinia Virus/ T7 RNA Polymerase Hybrid System

UNIT 16.19

This unit describes a transient cytoplasmic expression system that relies on the synthesis of the bacteriophage T7 RNA polymerase in the cytoplasm of mammalian cells. To begin, a gene of interest is inserted into a plasmid such that it comes under the control of the T7 RNA polymerase promoter ( $p_{T7}$ ). Using liposome-mediated transfection, this recombinant plasmid is introduced into the cytoplasm of cells infected with vTF7-3, a recombinant vaccinia virus encoding bacteriophage T7 RNA polymerase (first basic protocol). Alternatively, the plasmid may be used to transfect OST7-1, a stable cell line that constitutively expresses the T7 RNA polymerase. During incubation, the gene of interest is transcribed with high efficiency by T7 RNA polymerase. This transfection protocol is adequate for analytical purposes and is simple because no new recombinant viruses need to be made.

For large-scale work, the  $p_{T7}$ -regulated gene can be inserted into a second recombinant vaccinia virus by homologous recombination (UNIT 16.17) and used in combination with vTF7-3 to co-infect cells grown in suspension (second basic protocol) or used to infect OST7-1 cells (third basic protocol). Expressed protein is then analyzed by pulse-labeling (support protocol) or by the methods detailed in UNIT 16.18, and purified as described in UNIT 10.10.

## LIPOSOME-MEDIATED TRANSFECTION FOLLOWING RECOMBINANT VACCINIA VIRUS (vTF7-3) INFECTION

**BASIC  
PROTOCOL**

This protocol begins with a plasmid vector containing the gene of interest at a site between  $p_{T7}$  and the T7 terminator (Figs. 16.19.1 & 16.19.2; see also critical parameters). This recombinant plasmid is then introduced via liposome-mediated transfection (UNIT 9.4) into cells already infected with vaccinia virus vTF7-3 (a recombinant virus expressing the T7 RNA polymerase gene). After harvesting, the cells are analyzed for expression of the gene product as described in UNIT 16.18 or by pulse-labeling (support protocol).

### Materials

Recombinant plasmid: gene of interest subcloned (UNIT 3.16) into pTF7-5 or pTM1 vectors (available from B. Moss; Figs. 16.19.1 & 16.19.2) or other plasmid containing the T7 promoter (e.g., pBluescript, Stratagene; see UNIT 16.2 critical parameters and Fig. 1.10.8)

Confluent CV-1 cell monolayer (ATCC #CCL70; UNIT 16.16)

Complete DMEM-10 (UNIT 16.16)

vTF7-3 vaccinia virus stock (ATCC #VR-2153)

Opti-MEM I reduced serum medium (GIBCO/BRL #320-1985AJ)

Liposome suspension (Lipofectin or TransfectAce; GIBCO/BRL #8292SA and #8301SA, respectively)

6-well tissue culture dishes with 35-mm-diameter wells

Cup sonicator (385W)

12 × 75-mm polystyrene tubes (Falcon #2058)

Additional reagents and equipment for purification of plasmid DNA (UNIT 1.7)

**NOTE:** All incubations are performed in a humidified 37°C, 5% CO<sub>2</sub> incubator.

**Protein  
Expression**

**16.19.1**

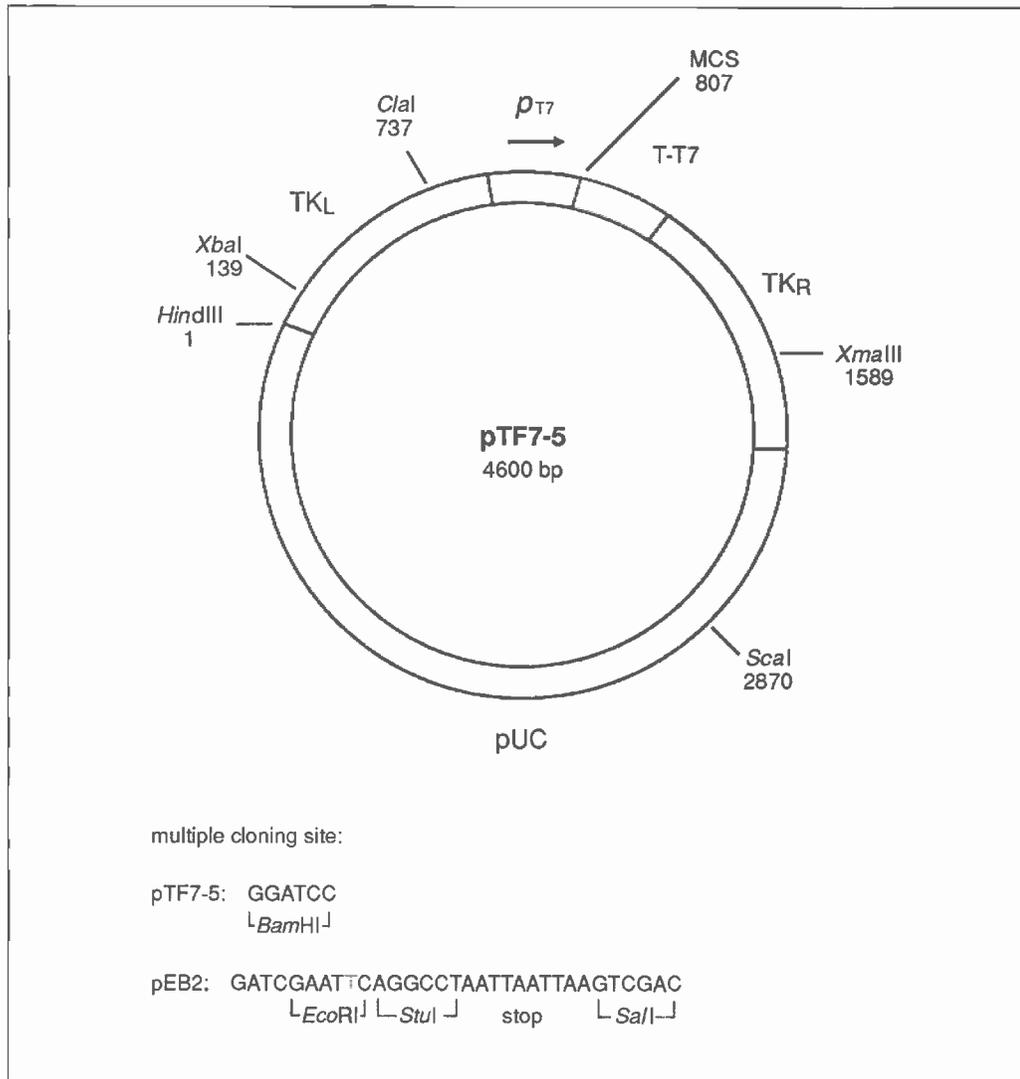

**Figure 16.19.1** pTF7-5 (Fuerst et al., 1986) contains  $p_{T7}$  and a terminator, between which is a unique *Bam*H1 site for insertion of a gene. The derivative, pEB2 (Berger et al., 1988) contains unique *Eco*RI and *Stu*I sites followed by translation stop codons in all three reading frames. The expression cassette is flanked by segments of the vaccinia virus TK gene; thus, TK<sup>-</sup> selection can be used for isolation of recombinant plaques (UNIT 16.17).

1. Purify recombinant plasmid DNA for transfection by CsCl/ethidium bromide centrifugation or PEG precipitation.

*Transfection will require 5 μg DNA/well of cells.*

*When using the pTM1 plasmid (Fig. 16.19.2), make sure that the initiator ATG of the gene of interest is the ATG of the pTM1 *Nco*I site (see critical parameters). Determine that the correct construction has been obtained by restriction mapping (UNIT 3.2).*

2. The day before infection, seed wells of a 6-well tissue culture dish with  $5 \times 10^5$  CV-1 cells/well in complete DMEM-10. Incubate until cells are near confluency (usually overnight).

*Cells should be counted with a hemacytometer.*

3. Vortex stock of vTF7-3 to disperse clumps. Sonicate the lysate using a cup sonicator as follows: (a) fill the cup with ice water (~50% ice); (b) place tube containing vTF7-3

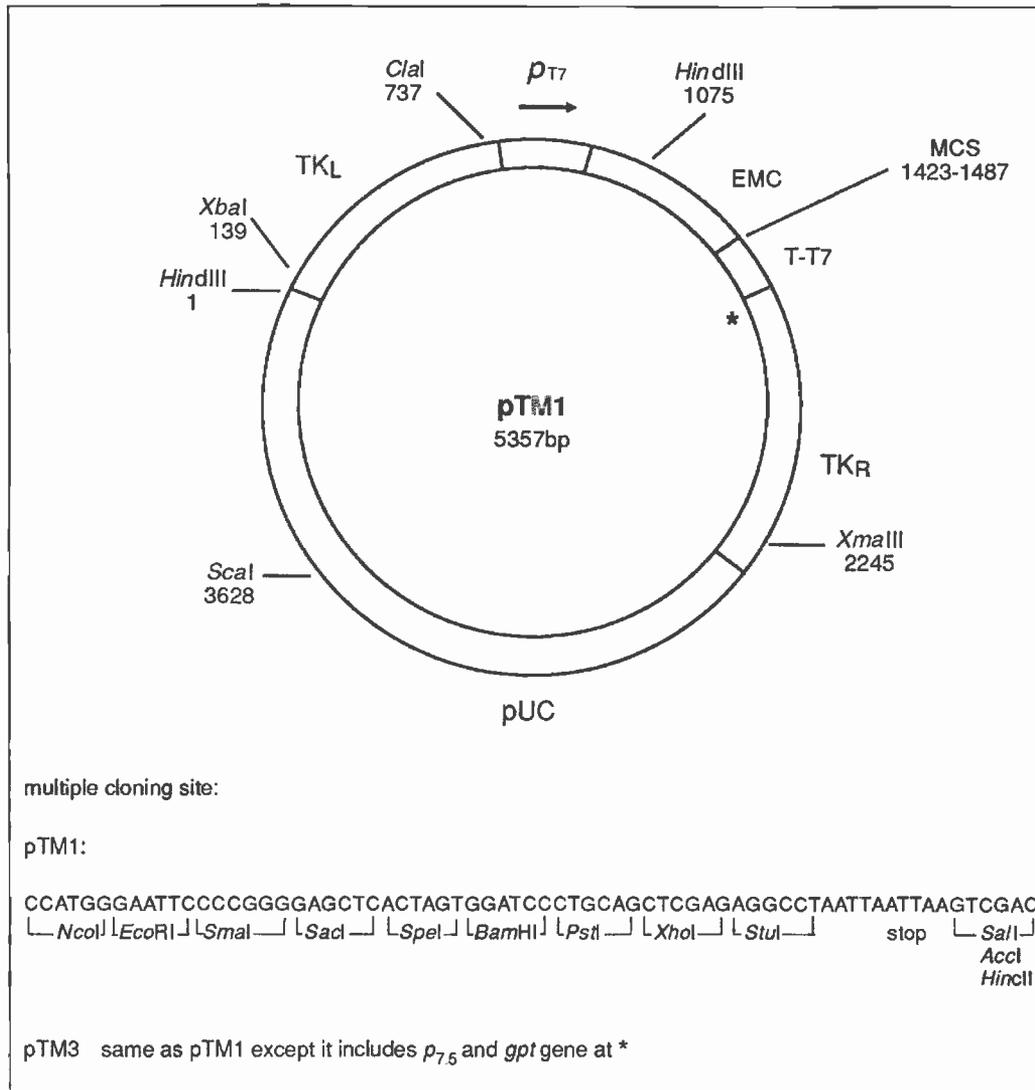

**Figure 16.19.2** pTM1 contains the encephalomyocarditis virus untranslated leader region (EMCV-UTR) downstream of  $p_{T7}$ . The *NcoI* site contains the translation initiation codon and should be used for insertion of the 5' end of the protein-coding DNA segment. The 3' end of the DNA can be inserted into any downstream sites preceding the T7 terminator. The expression cassette is flanked by segments of the vaccinia virus TK gene; thus, TK<sup>-</sup> selection can be used for isolation of recombinant virus (UNIT 16.17). pTM3 is the same as pTM1 except it includes the guanine phosphoribosyltransferase (*gpt*) gene to permit mycophenolic acid selection for recombinant virus (Moss et al., 1990; UNIT 9.5).

stock in the ice water; and (c) sonicate full power, 30 sec. Place lysate on ice  $\geq 30$  sec, then repeat sonication.

*Because sonication melts the ice, it is necessary to replenish the ice in the cup.*

*When only sonication is used to disrupt the stock, the virus titer is lower than if trypsinization (UNIT 16.16) is performed (the stock cannot be trypsinized because this would introduce serum into subsequent steps, resulting in inhibition of liposome-mediated transfection). Therefore, it is recommended that the titer of the virus stock following sonication be obtained (UNIT 16.16).*

4. Dilute an aliquot of the virus to  $2 \times 10^7$  PFU/ml in Opti-MEM I.

*Except for the initial cell culturing and seeding steps, serum must not be present in any other step of the experiment. Serum-free DMEM can be used, but for best results Opti-MEM I medium is recommended.*

5. Infect subconfluent monolayer of CV-1 cells from step 2 with 0.5 ml/well diluted virus stock (i.e., 10 PFU/cell). Incubate 30 min, rocking every 5 to 10 min.
6. Approximately 5 min before the end of the infection, prepare liposome suspension. Place 1 ml Opti-MEM I in separate 12 × 75-mm polystyrene tubes (one for each well to be tested). Vortex liposome suspension and add 15 µl to the medium; vortex briefly. Add 5 µg recombinant plasmid (from step 1) and mix gently.

*Vortex the liposome suspension before use to suspend the liposomes, which gradually settle during storage. Do not use a polypropylene tube, as the DNA/liposome complex may adhere to the surface.*

7. Aspirate virus inoculum from CV-1 cells and add the DNA/liposome complex directly to the cells. Incubate 5 to 24 hr, then analyze expressed protein by pulse labeling (support protocol) or by methods described in UNIT 16.18.

*The time needed for incubation depends on the analysis that will be done. Although expression is detectable within a few hours after transfection, pulse-labeling at late times is preferred because host protein synthesis is inhibited and synthesis of the recombinant protein is increased (UNIT 16.15).*

## BASIC PROTOCOL

### CO-INFECTION WITH TWO RECOMBINANT VACCINIA VIRUSES

The recombinant plasmid containing the gene of interest under control of  $p_{T7}$  (first basic protocol) is incorporated into vaccinia virus by homologous recombination (UNIT 16.17) and a stock is made (UNIT 16.16). This stock is used together with vTF7-3 to co-infect cells in monolayer or suspension cultures. During incubation, the gene of interest is efficiently transcribed by T7 RNA polymerase and translated in the cytoplasm of the infected cells. The protein is then analyzed (UNIT 16.18) or purified (UNIT 10.10).

This co-infection protocol is recommended for mass production of proteins. For this purpose, cells in suspension (i.e., Vero or HeLa S3 cells) are used.

#### Materials

- vTF7-3 vaccinia virus stock (ATCC #VR-2153)
- Stock of recombinant vaccinia virus encoding the gene of interest under control of  $p_{T7}$  (UNITS 16.16 & 16.17)
- Confluent monolayer culture of CV-1 cells (UNIT 16.16) or HeLa S3 cells from a spinner culture (UNIT 16.16)
- 0.25 mg/ml trypsin (Worthington 2× crystalline and salt-free; filter sterilize and stored at -20°C)
- Complete DMEM-10, MEM spinner-5, or MEM-2.5 (depends on cell type; see below and UNIT 16.16)
- Hemocytometer (UNIT 1.2)
- Sorvall H-6000 rotor or equivalent
- 6-well tissue culture dishes with 35-mm-diameter wells or larger tissue culture flasks for scaled-up analysis
- Additional reagents and equipment for counting cells with a hemacytometer (UNIT 1.2), vaccinia virus analysis (UNIT 16.18), and protein purification (UNIT 10.10)

**NOTE:** All incubations are performed in a humidified 37°C, 5% CO<sub>2</sub> incubator.

### ***Prepare the cells***

- 1a. *For infection of a CV-1 monolayer:* The day before infection, seed wells of a 6-well tissue culture dish with  $5 \times 10^5$  cells in complete DMEM-10. Incubate until cells are near confluency (usually overnight).

*Increase volumes proportionally if large-scale production is desired.*

- 1b. *For infection of HeLa S3 suspension cells:* Just prior to infection, count cells using a hemacytometer and centrifuge the desired amount 5 min at  $1800 \times g$  (2500 rpm in Sorvall H-6000 rotor), room temperature. Discard supernatant, resuspend cells in MEM spinner-5 medium at  $2 \times 10^7$  cells/ml, and transfer to a smaller sterile tissue culture flask or Erlenmeyer flask.
2. Trypsinize virus stocks. Place an aliquot of each stock in a separate tube and add an equal volume of 0.25 mg/ml trypsin. Vortex vigorously. Incubate 30 min, vortexing at 5- to 10-min intervals.

*The highest level of expression using this system is obtained with an MOI of 10 PFU/cell for each virus.*

*Vortexing usually breaks up any clumps of cells. However, if any visible clumps remain, chill to 0°C and sonicate 30 sec on ice. Sonication can be repeated several times but the sample should cool on ice between sonications (first basic protocol).*

3. Combine of the two trypsinized virus stocks.

### ***Infect the cells***

*For cells in monolayer culture:*

- 4a. Dilute trypsinized virus mixture with complete MEM-2.5 to  $4 \times 10^7$  PFU/ml.

*This represents  $2 \times 10^7$  PFU/ml from each virus stock.*

- 5a. Aspirate medium from cells and infect wells of a 6-well dish with 0.5 ml virus mixture per well. Incubate 1 to 2 hr, rocking dish at 15- to 30-min intervals.
- 6a. Overlay cells with 2 ml DMEM-10 and incubate. Analyze gene expression 5 to 24 hr after infection, depending on the method used. Alternatively, harvest 2 to 3 days after infection for protein purification.

*Although expression is detectable within a few hours after infection, analysis by immunoprecipitation, immunoblotting, or northern blotting is preferred at late times because the T7-regulated gene product accumulates to a higher level. Earlier analysis may be preferred for assaying the biological activity of the expressed protein.*

*For suspension cells:*

- 4b. Add trypsinized virus mixture to the concentrated cells. Stir with a sterile magnetic stir bar 30 min at 37°C.
- 5b. Transfer infected cells to a larger vented spinner flask and dilute with MEM spinner-5 to bring the cell density to  $5 \times 10^5$  cells/ml. Stir 1 to 3 days at 37°C.
- 6b. Harvest cells and analyze or purify the expressed protein (see annotation to step 6a above).

## **INFECTION OF OST7-1 CELLS WITH A SINGLE VIRUS**

OST7-1 cells are derived from mouse L929 cells and constitutively express the bacteriophage T7 RNA polymerase in the cytoplasm. Thus, using this cell line eliminates the need for infection with  $\nu$ TF7-3. This protocol describes the infection of OST7-1 cells with a single recombinant virus containing the gene of interest.

### *Materials*

- Confluent monolayer of OST7-1 cells (available from B. Moss)
- Complete DMEM-10 (UNIT 16.16) containing 400 potent  $\mu$ g/ml Geneticin (G418, UNIT 9.5; GIBCO/BRL #860-1811-IJ; prepared from 80 mg/ml stock in PBS, filter sterilized and stored at  $-20^{\circ}\text{C}$ )
- Stock of recombinant vaccinia virus containing the gene of interest under the control of  $p_{T7}$  promoter (UNITS 16.16 & 16.17)
- 0.25 mg/ml trypsin (Worthington 2 $\times$  crystalline and salt-free; filter sterilize and store at  $-20^{\circ}\text{C}$ )
- Complete MEM-2.5 (UNIT 16.16)
- 6-well tissue culture dish with 35-mm-diameter wells

*NOTE:* All incubations are performed in a humidified  $37^{\circ}\text{C}$ , 5%  $\text{CO}_2$  incubator.

1. Seed wells of a 6-well tissue culture dish with  $1 \times 10^6$  OST7-1 cells/well in complete DMEM-10 containing 400 potent  $\mu$ g/ml Geneticin. Incubate until cells reach confluency (usually overnight).  
*Complete DMEM-10 containing Geneticin is used to maintain the culture, but Geneticin is not required for the expression experiment itself.*
2. Mix an equal volume of the virus stock and 0.25 mg/ml trypsin by vortexing vigorously. Incubate 30 min at  $37^{\circ}\text{C}$ , vortexing at 5- to 10-min intervals.  
*Use an MOI of 10 PFU/cell.*
3. Dilute the trypsinized virus to  $2 \times 10^7$  PFU/ml with complete MEM-2.5.
4. Infect confluent monolayer of OST7-1 cells with 0.5 ml virus mixture/well. Incubate 1 to 2 hr, rocking at 15- to 30-min intervals.
5. Add 1.5 ml/well complete MEM-2.5 and continue to incubate.
6. Analyze the cells 3 to 24 hr after infection (see annotation to step 6a, second basic protocol).

## **DETECTION OF EXPRESSED PROTEIN USING PULSE LABELING**

Pulse labeling infected cells is a quick and sensitive way to monitor expression of the T7-regulated gene relative to expression of vaccinia late proteins. When performed 24 hr postinfection under optimal conditions, up to 80% of the [ $^{35}\text{S}$ ]methionine is incorporated into the product of the T7-regulated gene. This protein is detected using SDS-PAGE. If the EMC untranslated leader is present (e.g., if the pTM1 plasmid is used), hypertonic conditions may be used to selectively enhance cap-independent translation.

### *Additional Materials*

- Infected cells expressing the desired T7-regulated gene of interest (first, second, or third basic protocols) in a 6-well tissue culture dish
- Methionine- or cysteine-free, serum-free MEM (GIBCO/BRL, Select-Amine Kit #300-9050 AV)

15 mCi/ml [<sup>35</sup>S]methionine (1000 Ci/mmol; Amersham #SJ1515) or  
15 mCi/ml [<sup>35</sup>S]cysteine (600 Ci/mmol; Amersham #SJ232)

Phosphate-buffered saline (PBS; APPENDIX 2), ice-cold

Lysis buffer (UNIT 16.18)

6× SDS/sample buffer (UNIT 10.2)

Fixing solution (UNIT 10.6)

Fluorographic solution (EN<sup>3</sup>HANCE, Du Pont #NEF-981; or Amplify,  
Amersham #NAMP-100)

Cell scraper

Additional reagents and equipment for denaturing (SDS) gel electrophoresis  
(UNIT 10.2) and autoradiography (APPENDIX 3)

**NOTE:** All incubations are performed in a humidified 37°C, 5% CO<sub>2</sub> incubator.

#### **Label the cells**

1. Obtain infected cells expressing the desired T7-regulated gene of interest 24 hr after infection. Aspirate medium and replace it with 0.3 ml methionine- or cysteine-free MEM per well. Incubate 20 min.

*Hypertonic conditions selectively enhance cap-independent translation. Therefore, if the EMC leader is present in the plasmid used in the infection (e.g., pTM1; Fig. 16.19.2), add 4.8 μl of 5 M NaCl to each well (190 mM final).*

2. Add 30 μCi (2 μl) of [<sup>35</sup>S]methionine or [<sup>35</sup>S]cysteine to each well. Incubate 30 min.

#### **Lyse the cells**

3. Aspirate medium and add 1 ml ice-cold PBS to each well.
4. Scrape cells with a disposable cell scraper and transfer to a 1.5-ml microcentrifuge tube. Microcentrifuge 1 min at high speed. Aspirate and discard supernatant.
5. Resuspend cell pellet in 100 μl lysis buffer. Vortex briefly and incubate 5 min on ice.
6. Microcentrifuge 5 min at high speed and transfer supernatant to a clean microcentrifuge tube.

#### **Analyze proteins**

7. Remove 10 μl lysate and place in another microcentrifuge tube with 2 μl 6× SDS/sample buffer. Heat 5 min at 95°C.
8. Load sample on single well of an SDS-polyacrylamide gel.

*A 10% polyacrylamide gel is recommended for separation of vaccinia late proteins that will appear as background bands on the autoradiogram.*

*It is important to use a control of infected cells that do not express the gene of interest.*

9. Fix gel 20 min in fixing solution.
10. Incubate gel in fluorographic solution according to manufacturer's instructions.
11. Dry gel and expose to X-ray film.

*If the pTM1 vector is used, the gene product expressed under hypertonic conditions is usually at a high enough level to appear as a major band among the vaccinia virus late gene products. If the T7-regulated gene product co-migrates with a vaccinia gene product, it will be necessary to analyze the expression using other methods as described in UNIT 16.18.*

## COMMENTARY

### Background Information

Among the most efficient procedures for expression of genes in the cytoplasm of mammalian cells utilizes a recombinant vaccinia virus encoding the bacteriophage T7 RNA polymerase. Many of the properties of T7 RNA polymerase that contribute to its successful use in prokaryotic gene expression (*UNIT 16.2*) are also relevant to its application for expression in eukaryotic cells. These properties include (1) the single subunit structure of T7 RNA polymerase, (2) the processive transcriptase activity of the enzyme, and (3) stringent promoter specificity in the eukaryotic cytoplasm.

In one version of the hybrid expression system described in this unit, plasmid DNA containing a gene of interest under the control of the  $p_{T7}$  promoter is transfected into cells infected with the recombinant vaccinia virus, after which the gene is transcribed efficiently by T7 RNA polymerase (Fuerst et al., 1986). Alternatively, DNA can be transfected into a cell line that constitutively expresses T7 RNA polymerase in the cytoplasm. However, for reasons that remain unclear, high-level expression in this cell line still requires infection with wild-type vaccinia virus (even when the cap-independent EMC virus untranslated region is used; Elroy-Stein and Moss, 1990). Therefore, the T7RNA polymerase–cell line does not offer a clear advantage over the T7 RNA polymerase–vaccinia virus recombinant for transfection experiments.

In the vaccinia/T7 system, mRNA derived from the transfected gene can be as much as 10% to 30% of total cytoplasmic RNA. However, although mRNA levels of the T7-regulated gene are often quite high, only moderate amounts of protein are made. This limited translation is presumably due to the low efficiency of capping the transcripts made by T7 RNA polymerase (Fuerst and Moss, 1989). This difficulty was addressed by incorporating a feature of picornavirus mRNAs—a long untranslated leader region (UTR or “ribosomal landing pad”) that facilitates cap-independent ribosome binding—just downstream of the T7 promoter in certain vectors. The use of such vectors (e.g., pTM1; Fig. 16.19.2) in the vaccinia/T7 system enhances expression 5- to 10-fold (Elroy-Stein et al., 1989).

Some users of this system have experienced problems with the efficiency and repro-

ducibility of introducing DNA into the cell. These problems have been successfully resolved by the use of cationic liposome-mediated transfection to deliver plasmid DNA into vaccinia-infected cells. This method has reproducibly allowed 80% to 99% of the cells to be transfected (Felgner et al., 1987; Elroy-Stein and Moss, 1990; Rose et al., 1990; see also *UNIT 9.4*).

### Critical Parameters

To maximize protein expression, the gene of interest is cloned into a plasmid vector (e.g., pTF7-5 or pTM1) that contains both  $p_{T7}$  and the T7 terminator (Figs. 16.19.1 & 16.19.2). Better expression (5- to 10-fold) is obtained by using the encephalomyocarditis virus (EMCV)-UTR downstream of  $p_{T7}$  in pTM1. Alternatively, any plasmid that carries the T7 promoter (e.g., pBluescript; see *UNIT 16.2* critical parameters) can be used but may give lower expression levels.

When the “ribosomal landing pad” within the EMCV-UTR is used, translation initiation occurs at the ATG, which in pTM-1 happens to be in the *NcoI* site. If native protein is to be expressed, the initiator ATG codon must be in the *NcoI* site. If necessary, the *NcoI* site may be mutated but the position of the initiator ATG should not be changed. If a fusion protein is desired, the coding sequence is inserted into one of the multiple cloning sites, in frame with the ATG of the *NcoI* site.

For some methods of detection (e.g., immunofluorescence; Earl et al., 1990), it is preferable to harvest the cells  $\leq 24$  hr after transfection. If the incubation continues much beyond this point, the cells may detach from the monolayer and be lost during washing or staining.

For analytical purposes, expression can be achieved by transfecting the recombinant plasmid into cells that have been infected with a recombinant vaccinia virus, such as vTF7-3, which expresses the T7 RNA polymerase gene. For mass production of proteins—e.g., 8  $\mu$ g CAT/ $10^6$  cells (Elroy-Stein et al., 1989) or 11 mg HIV envelope protein/liter (Barret et al., 1989)—a recombinant vaccinia virus that contains the  $p_{T7}$ -regulated target gene should be generated by homologous recombination (*UNIT 16.17*). It should be introduced into cells constitutively expressing the T7 RNA polymerase, or used with vTF7-3 to co-infect any mammalian or avian cell line.

## Anticipated Results

In most cases, 60% to 90% of transfected cells (following infection with vTF7-3) or 99% of infected cells (when the gene of interest is incorporated in a vaccinia virus) are observed to express the desired protein. If protein is being detected by pulse labeling, an overnight exposure should result in the protein product appearing as a dominant band over the background of vaccinia proteins.

## Time Considerations

Starting with a plasmid containing the gene of interest cloned in the appropriate vector, the entire procedure from infection or infection/transfection to harvesting and analyzing the expressed product requires 2 to 3 days.

## Literature Cited

- Barret, N., Mitterer, A., Mundt, W., Eibl, J., Eibl, M., Gallo, R.C., Moss, B. and Dorner, F. 1989. Large-scale production and purification of a vaccinia recombinant-derived HIV-1 gp160 and analysis of its immunogenicity. *AIDS Res. Hum. Retroviruses* 5:159-171.
- Berger, E.A., Fuerst, T.R., and Moss, B. 1988. A soluble recombinant polypeptide comprising the amino-terminal half of the extracellular region of the CD4 molecule contains an active binding site for human immunodeficiency virus. *Proc. Natl. Acad. Sci. U.S.A.* 85:2357-2361.
- Earl, P.L., Koenig, S. and Moss, B. 1990. Biological and immunological properties of human immunodeficiency virus type 1 envelope glycoprotein: Analysis of proteins with truncations and deletions expressed by recombinant vaccinia viruses. *J. Virol.* 65:31-41.
- Elroy-Stein, O., Fuerst, T.R., and Moss, B. 1989. Cap-independent translation of mRNA conferred by encephalomyocarditis virus 5' sequence improves the performance of the vaccinia virus/bacteriophage T7 hybrid expression system. *Proc. Natl. Acad. Sci. U.S.A.* 86:6126-6130.
- Elroy-Stein, O. and Moss, B. 1990. Cytoplasmic expression system based on constitutive synthesis of bacteriophage T7 RNA polymerase in mammalian cells. *Proc. Natl. Acad. Sci. U.S.A.* 87:6743-6747.
- Felgner, P.L., Gadek, T.R., Holm, H., Roman, R., Chan, H.W., Wenz, M., Northrop, J.P., Ringold, G.A., and Danielsen, G.A. 1987. Lipofection: A highly efficient, lipid-mediated DNA transfection procedure. *Proc. Natl. Acad. Sci. U.S.A.* 84:7413-7417.
- Fuerst, T.R. and Moss, B. 1989. Structure and stability of mRNA synthesized by vaccinia virus-encoded bacteriophage T7 RNA polymerase in mammalian cells. Importance of the 5' untranslated leader. *J. Mol. Biol.* 206:333-348.
- Fuerst, T.R., Niles, E.G., Studier, F.W., and Moss, B. 1986. Eukaryotic transient expression system based on recombinant vaccinia virus that synthesizes bacteriophage T7 RNA polymerase. *Proc. Natl. Acad. Sci. U.S.A.* 83:8122-8126.
- Moss, B., Elroy-Stein, O., Mizukami, T., Alexander, W.A., and Fuerst, T.R. 1990. New mammalian expression vectors. *Nature (Lond.)* 348:91-92.
- Rose, J.K., Buonocore, L., and Whitt, M.A. 1991. A new cationic liposome reagent mediating nearly quantitative transfection of animal cells. *Biotechniques* 10:520-525.

---

Contributed by Orna Elroy-Stein  
Tel Aviv University  
Tel Aviv, Israel

Bernard Moss  
National Institute of Allergy and  
Infectious Diseases  
Bethesda, Maryland

# Expression of Proteins Using Semliki Forest Virus Vectors

Semliki Forest virus (SFV) vectors have been developed to provide a convenient system to express protein-encoding sequences in virtually any animal cell. This unit presents two strategies for protein expression using SFV vectors. In both cases the protein-coding sequence of interest is cloned into a plasmid vector, which is subsequently used to produce recombinant RNA *in vitro*. This RNA, which is of positive polarity, is transfected into cells and there is amplified by virtue of its self-encoded RNA replicase. The same replicase also produces a shorter RNA species that encodes the protein of interest.

Protein expression can be achieved in two ways. In the first strategy, cells are transfected and directly analyzed for expression of the heterologous protein. The other strategy employs *in vivo* packaging of the RNA into SFV particles; recombinant RNA is cotransfected with a special helper RNA that codes for the structural proteins needed for virus assembly. SFV particles carrying only recombinant RNA are formed and are used to infect cells for analysis of protein expression. The first expression strategy is useful when studying the phenotypic expression of several mutant genes, in preliminary gene expression analyses, and when only a limited amount of expression studies are planned for one construct. The second strategy is more useful when many expression analyses are planned with the same construct and when large-scale production of the gene product is planned.

The first basic and alternate protocols employ the first strategy and differ only in transfection procedure (electroporation and liposome-mediated transfection, respectively). Accompanying support protocols provide methods for checking expression and transfection through  $\beta$ -galactosidase assays of transfected cells and cell lysates. The second basic protocol uses the second strategy and is accompanied by support protocols providing methods for titrating and purifying recombinant virus stocks. Although the protocols presented here are designed for use with BHK (baby hamster kidney) cells, the virus has a very broad host range and can be used with many different cell types (see Background Information).

## STRATEGIC PLANNING: CHOICE OF SFV VECTOR

The available SFV vectors are all pGEM-based, confer ampicillin resistance, and carry the SFV replicase-encoding genes *nsP1-4* followed by a promoter for subgenomic transcription (Fig. 16.20.1). A unique *SpeI* restriction site is placed at the 3' end of the SFV-derived sequence to permit linearization of the plasmid prior to runoff transcription *in vitro*. Downstream from the subgenomic promoter (which overlaps with the 3' end of the *nsP4* gene) is a polylinker site (*Bam*HI-*Sma*I-*Xma*I) where the foreign DNA sequence is inserted. Following the polylinker are translational stop codons in all three reading frames (in case the inserted sequence lacks a stop codon).

The basic vector is pSFV1, which is used when the inserted DNA fragment contains an initiation codon (AUG) preceded by its own Kozak box (sequence specifying ribosome binding). pSFV3 contains a Kozak box and a start codon and is used when the inserted sequence lacks these elements; it provides proper translation as long as the inserted sequence is placed in frame with the initiating AUG of the vector. pSFV3-lacZ contains an added copy of the *E. coli*  $\beta$ -galactosidase gene and is used as a convenient control.

**NOTE:** Consult UNIT 4.1 for recommendations for minimizing contamination of RNA preparations by ribonucleases and Critical Parameters regarding precautions for working with SFV particles.

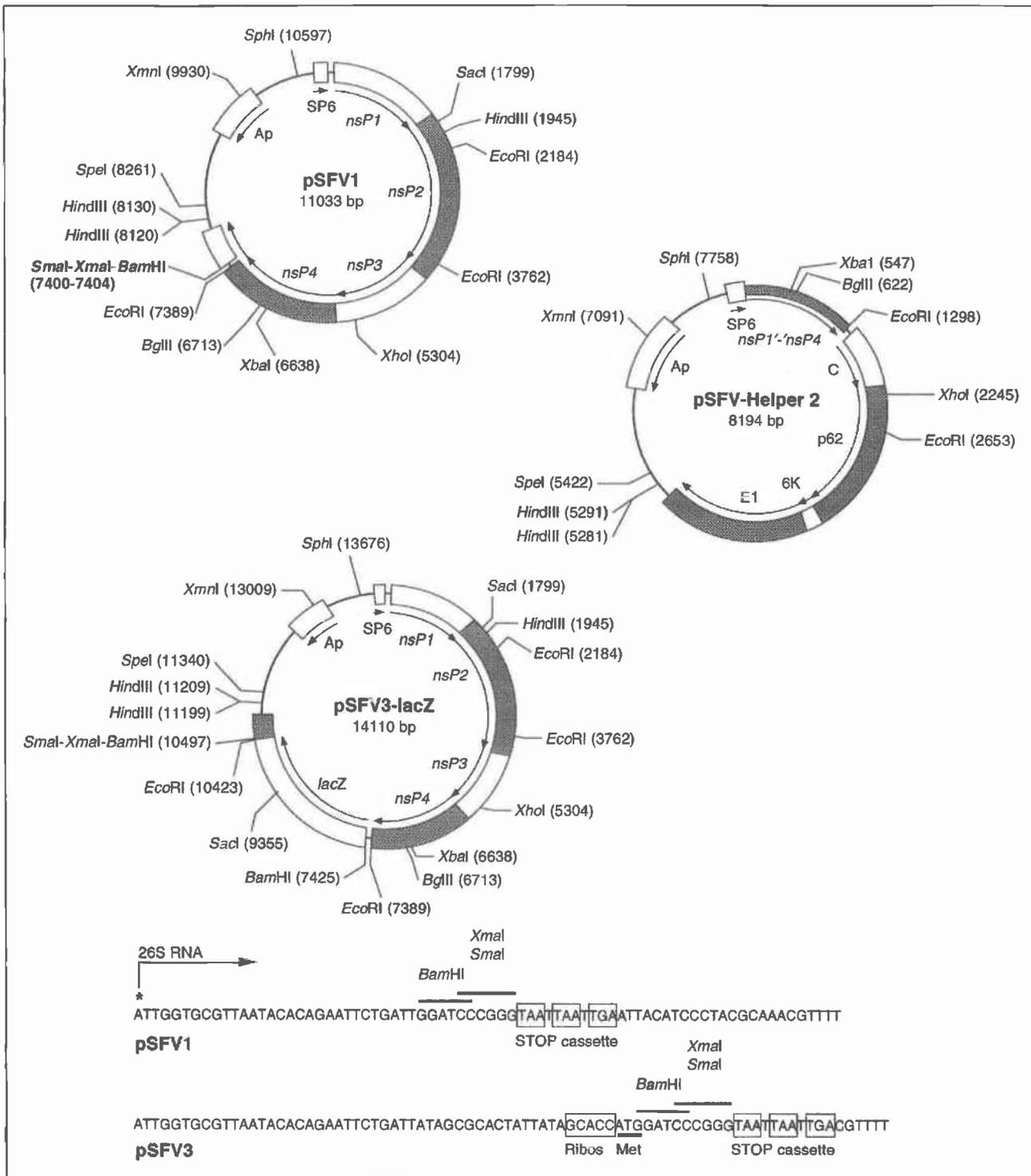

**Figure 16.20.1** SFV expression vectors and their polylinker regions. pSFV1 and pSFV3 are almost identical in size and structure, differing only in their polylinker regions; pSFV3-lacZ is a variant of pSFV-3 containing an inserted copy of the *E. coli*  $\beta$ -galactosidase gene. These vectors carry the four genes encoding the SFV replicase (*nsP1-4*) but lack the structural genes of SFV (C, p62, 6K, and E1). In contrast, the Helper plasmid lacks the *nsP* genes (the corresponding deletion flanking the remaining *nsP* sequences is indicated as *nsP1'-nsP4*, where the primes indicate the position of the deletion) but carries the structural genes. For all three plasmids, in vitro transcription is driven by the SP6 promoter. The unique *SpeI* site is used to linearize the plasmids prior to transcription. Sequences flanking the polylinker regions of pSFV1 and pSFV3 are shown below the plasmid maps. The first nucleotide transcribed from the subgenomic promoter, indicated above the pSFV1 sequence, is the same for all three plasmids. (Consult Liljeström and Garoff, 1991b, Liljeström et al., 1991; and Berglund et al., 1993 for further details).

## 16.20.2

## EXPRESSION OF PROTEINS FROM RECOMBINANT SFV RNA USING ELECTROPORATIVE TRANSFECTION

## BASIC PROTOCOL

SFV vector plasmids carrying heterologous sequences are used as templates for RNA synthesis *in vitro*. The RNA is transfected into BHK cells by electroporation, where the self-encoded RNA replicase amplifies the RNA molecules. In conjunction with efficient translational start signals resident on the RNA molecules, this ensures a high production rate for the heterologous protein. Production is easily monitored by metabolic labeling of transfected cells and analysis of the protein products by SDS-PAGE and autoradiography.

### Materials

DNA fragment encoding protein of interest  
pSFV1, pSFV3, or pSFV3-lacZ expression vector (GIBCO/BRL; see Fig. 16.20.1)  
*SpeI* restriction endonuclease and buffer (UNIT 3.1)  
10× SP6 RNA polymerase buffer  
50 mM dithiothreitol (DTT)  
10 mM <sup>m7</sup>G(5')ppp(5')G  
rNTP mix  
40 U/μl RNasin (Promega) or other RNase inhibitor  
60 U/μl SP6 RNA polymerase (UNIT 3.8)  
5× TD solution  
λ DNA molecular weight markers (e.g., λ digested with *EcoRI* + *HindIII*; UNIT 2.5A)  
BHK-21 cells (ATCC)  
Complete BHK-21 medium  
Phosphate-buffered saline (PBS; Reagents and Solutions), 37°C, room temperature, and ice cold  
Trypsin/EDTA solution: 0.5 mg/ml trypsin/0.2 mg/ml EDTA in PBS  
Starvation medium  
15 mCi/ml [<sup>35</sup>S]methionine (>1000 Ci/mmol)  
Chase medium  
NP-40 lysis buffer  
75-cm<sup>2</sup> tissue culture flask  
Electroporator (e.g., Bio-Rad)  
0.2- or 0.4-cm electroporation cuvette  
35-mm tissue culture plate  
Additional reagents and equipment for subcloning (UNIT 3.16), preparation of plasmid DNA (UNIT 1.7), restriction endonuclease digestion (UNIT 3.1), phenol extraction and ethanol precipitation of DNA (UNIT 2.1), spectrophotometric quantitation of RNA and DNA (APPENDIX 3), agarose gel electrophoresis (UNIT 2.5A), SDS-PAGE for protein analysis (UNIT 10.2), and autoradiography (APPENDIX 3)

**NOTE:** All solutions and equipment coming into contact with cells must be sterile, and proper sterile technique should be used accordingly. All incubations are performed in a humidified, 37°C, 5% CO<sub>2</sub> incubator unless otherwise specified.

### Subclone fragment and prepare RNA by *in vitro* transcription

1. Subclone the DNA fragment of interest into an SFV expression vector. Grow up resulting plasmid and prepare purified DNA.
2. Linearize recombinant plasmid DNA by restriction digestion with *SpeI*. Phenol extract and ethanol precipitate the DNA. Determine DNA concentration and resuspend in water at 0.3 μg/μl.

### Protein Expression

## 16.20.3

3. Set up *in vitro* transcription in a microcentrifuge tube by mixing the following:

- 5  $\mu$ l DNA (1.5  $\mu$ g)
- 5  $\mu$ l 10 $\times$  SP6 buffer
- 5  $\mu$ l 50 mM DTT
- 5  $\mu$ l 10 mM  $^{m7}$ G(5')ppp(5')G
- 5  $\mu$ l rNTP mix
- 23  $\mu$ l H<sub>2</sub>O
- 1.5  $\mu$ l 40 U/ $\mu$ l RNasin
- 0.5  $\mu$ l 60 U/ $\mu$ l SP6 RNA polymerase.

*Because the spermidine in the SP6 buffer may precipitate DNA at 0°C, the reaction should be set up at room temperature. Under the conditions described (1.5  $\mu$ g of linear DNA and 30 U of SP6 RNA polymerase per reaction), the transcription mixture is saturated for DNA and should yield ~50  $\mu$ g of RNA. The yield can be increased by increasing the amount of SP6 RNA polymerase used.*

4. Incubate 60 min in a 37°C water bath. Transfer a 1- $\mu$ l aliquot into 10  $\mu$ l water and add 3  $\mu$ l of 5 $\times$  TD solution. Run sample on a 0.5% agarose gel, using digested  $\lambda$  DNA as a molecular weight marker. Freeze the remainder of the reaction in 10- $\mu$ l aliquots at -80°C.

*Although the gel is nondenaturing and thus does not reflect the molecular weight of the RNA produced, it is nevertheless useful for checking RNA quality and quantity. The RNA band should be defined (no smearing) and relatively thick in comparison to DNA bands. If desired, RNA samples of known concentration can be run as a rough quantitative comparison.*

#### **Transfect BHK-21 cells by electroporation**

5. Inoculate BHK-21 cells into 10 ml complete BHK-21 medium in a 75-cm<sup>2</sup> tissue culture flask and grow to late log phase (this will usually take 1 to 2 days).
6. Aspirate medium and wash cells once with room-temperature PBS.
7. Add 2 ml trypsin/EDTA solution, incubate until cells detach (~1 min), and briefly pipet cell solution back and forth, monitoring under a microscope, to obtain a single-cell suspension. Add 10 ml complete BHK-21 medium to stop trypsinization.
8. Centrifuge cells 5 min at 400  $\times$  g, room temperature, in a tabletop centrifuge and remove supernatant. Resuspend cells in 10 to 20 ml PBS.
9. Centrifuge cells as in the previous step and resuspend in PBS at 10<sup>7</sup> cells/ml.
10. Thaw an aliquot of the RNA to be transfected (transcription mixture from step 4), place 10 to 15  $\mu$ l in a microcentrifuge tube, and add 0.8 ml of cell suspension. Mix thoroughly by pipetting and transfer to a 0.2- or 0.4-cm electroporation cuvette.

*Using 4  $\mu$ g RNA per 10<sup>7</sup> cells will give a transfection frequency close to 100%. Thus, using 10 to 15  $\mu$ l transcription mixture (~5 to 7  $\mu$ g RNA) per 75-cm<sup>2</sup> flask works well.*

11. Pulse twice at room temperature using a voltage of 850 V, a capacitor setting of 25  $\mu$ F, and a time constant after the pulse of 0.4.

*If a large number of samples are being manipulated and cells start to sediment in the cuvettes before the pulse, cap each cuvette tightly and invert once before shocking.*

*The Bio-Rad gene pulser uses capacitor discharges to produce pulses, generating an exponential-decay waveform. For this electroporator the pulse-controller should be disconnected when using 0.4-cm cuvettes; in this case the set value of 850 V will represent the actual voltage given to cells in the cuvette (i.e., field strength = 2125 V/cm). When using 0.2-cm cuvettes, the pulse-controller must be connected to prevent*

*arcng. In this case, however, the set V value will not represent what is given to the cells, so the actual V required to obtain the proper field strength should be determined by measuring the pulse directly in the cuvette (generally ~1700 V). If an electroporator other than the Bio-Rad model is used, settings may need to be modified; consult UNITS 9.3 & 9.9 for recommendations.*

12. Dilute transfected cells 20-fold in complete BHK-21 medium, rinsing the cuvette with the medium to collect all cells, and transfer to a 35-mm tissue culture plate. Incubate 7 to 9 hr.

*Cells will reattach in ~1 hr and metabolic labeling can be performed as early as 4 hr after transfection. However, for maximum labeling of the protein of interest and minimum labeling of host proteins, incubation for 7 to 9 hr after transfection is recommended.*

#### **Analyze heterologous protein by metabolic labeling of cells**

13. Aspirate medium and wash cells twice with 3 ml prewarmed PBS. Overlay cells with 2 ml starvation medium and incubate plate 30 to 45 min.
14. Prepare 500  $\mu$ l of pulse medium: starvation medium containing 25 to 50  $\mu$ Ci [<sup>35</sup>S]methionine. Aspirate medium from cells, replace with pulse medium, and incubate for the desired pulse time.

*Consult UNIT 10.18 for a discussion of how to select appropriate pulse and chase times.*

15. Remove pulse medium and wash cells once with 2 ml chase medium. Overlay cells with 2 ml chase medium and incubate for desired chase time.
16. Remove chase medium and wash cells with 3 ml ice-cold PBS.
17. Add 300  $\mu$ l NP-40 lysis buffer and incubate 10 min on ice.
18. Resuspend cells and transfer to a microcentrifuge tube. Microcentrifuge 5 min at 6000 rpm at 4°C or room temperature to pellet nuclei. Store supernatant (cytoplasmic proteins) or pellet (nuclear proteins) at -80°C.
19. Assay for protein expression by SDS-PAGE and autoradiography.

*If pSFV3-lacZ was used, expression and transfection efficiencies can be checked using the  $\beta$ -galactosidase expression assays described in the first and second support protocols.*

### **EXPRESSION OF PROTEINS FROM RECOMBINANT SFV RNA USING LIPOSOME-MEDIATED TRANSFECTION**

If a gene pulser is not available, liposome-mediated transfection can replace electroporation (steps 5 to 12 of the first basic protocol). With this method, the transcription mixture must be purified to remove the NTPs from the reaction mixture, either by gel filtration or by isopropanol precipitation of the RNA with a subsequent ethanol wash.

#### **Additional Materials**

- TE buffer, pH 7.5 (APPENDIX 2)
- 3 M sodium acetate, pH 4.8 (APPENDIX 2)
- Opti-MEM transfection medium (GIBCO/BRL)
- Isopropanol, -20°C
- 75% (v/v) ethanol
- Lipofectin (GIBCO/BRL)
- Nu-Clean R50 RNA spin columns (IBI)
- Centrifuge with swinging-bucket rotor

#### **ALTERNATE PROTOCOL**

#### **Protein Expression**

### **16.20.5**

**NOTE:** All solutions and equipment coming into contact with cells must be sterile, and proper sterile technique should be used accordingly. All incubations are performed in a humidified, 37°C, 5% CO<sub>2</sub> incubator unless otherwise specified.

1. Prepare RNA by in vitro transcription as described in steps 1 to 4 of the preceding basic protocol.

*To purify RNA by gel filtration:*

- 2a. Warm column to room temperature and invert several times to resuspend gel. Remove top and bottom caps and allow excess buffer to drain out of the column.
- 3a. Position the column on top of a 1.5-ml microcentrifuge tube placed within bucket of a swinging-bucket rotor and prespin 2 min at 1100 × g. Discard collection tube and replace with a fresh one.
- 4a. Thaw transcription mixture. If necessary, dilute with TE buffer to a final volume of 50 μl (volumes between 50 and 100 μl can be used). Add sample directly to top of column and spin again as in step 3a. Discard column. Aliquot 20 μl of the purified RNA sample (from collection tube) and freeze at -80°C.

*To purify RNA by isopropanol precipitation:*

- 2b. Thaw transcription reaction mixture and dilute with water to 100 μl. Add 20 μl of 3 M sodium acetate, pH 4.8.
- 3b. Add 72 μl of -20°C isopropanol, mix, and incubate 10 min at room temperature.
- 4b. Microcentrifuge 15 min at top speed, room temperature. Remove supernatant, rinse with 500 μl of 75% ethanol, respin, remove ethanol, and briefly dry. Resuspend pellet in 50 μl TE buffer, pH 7.5.

*Only DNA or RNA >100 bp is precipitated by this method. However, it is important that the precipitation step be performed at room temperature.*

5. Grow BHK-21 cells on 35-mm tissue culture plates to ~80% confluency.
6. Remove medium and replace with 2 ml Opti-MEM medium. Incubate 5 to 10 min.
7. While cells are incubating, mix 1 ml Opti-MEM with 9 μg Lipofectin (per plate of cells) and vortex mixture for 10 sec. Add 2.3 μg purified RNA (step 4a or 4b) and vortex again.
8. Remove the Opti-MEM covering the cells and replace with Opti-MEM/Lipofectin/RNA mixture. Incubate 2 hr, tilting the plate every 15 min.

*Up to 90% transfection frequencies can be obtained using Lipofectin. However, it is imperative that the transfection mixture always cover the cells as evenly as possible. Frequent tilting of plates is recommended for consistent results.*

9. Remove transfection mix and wash cells once with 2 ml complete BHK-21 medium. Add 2 to 3 ml complete BHK-21 medium and continue incubation 7 to 9 hr.
10. Analyze heterologous protein by metabolic labeling of cells as described in steps 13 to 19 of the first basic protocol.

## SCREENING FOR GENE EXPRESSION USING $\beta$ -GALACTOSIDASE

The pSFV3-lacZ vector can be used to check expression and transfection efficiencies. A quick, convenient method to screen cells for lacZ expression is by direct staining with Xgal. Alternatively, an infected cell lysate can be assayed for  $\beta$ -galactosidase activity.

### Screening of Cells for $\beta$ -Galactosidase Activity

#### Materials

BHK-21 cells transfected with pSFV-lacZ vector (first basic protocol, step 12, or first alternate protocol, step 9)  
Methanol,  $-20^{\circ}\text{C}$   
Xgal stain solution  
Stereomicroscope

1. Following infection or transfection to permit expression of  $\beta$ -galactosidase, incubate cells 7 hr to overnight.
2. Wash cells twice with PBS. Add 3 ml of  $-20^{\circ}\text{C}$  methanol and incubate plate 5 min at  $-20^{\circ}\text{C}$  to fix the cells.
3. Wash cells three times with PBS at room temperature and overlay with 1 ml Xgal stain solution. Monitor the ratio of positive (blue) to negative (white) cells using a stereomicroscope.

*Staining is usually quite fast (beginning within minutes) and is complete after 2 to 4 hr at  $37^{\circ}\text{C}$ . Alternatively, plates can be left at room temperature overnight.*

*The ratio of blue to white cells serves as an indication of transfection efficiency.*

### Screening of Cell Lysates for $\beta$ -Galactosidase Activity

#### Additional Materials

Lysate of BHK-21 cells transfected with pSFV3-lacZ vector (first basic or alternate protocol)  
Z buffer with and without 4 mg/ml *o*-nitrophenyl- $\beta$ -D-galactopyranoside (ONPG)  
Purified  $\beta$ -galactosidase  
1 M sodium carbonate

1. Place 1  $\mu\text{l}$  cell lysate ( $\sim$ 200 to 300 cell equivalents) in a 1.5-ml microcentrifuge tube and add Z buffer to 400  $\mu\text{l}$ . Incubate 5 min.
2. Add 100  $\mu\text{l}$  of 4 mg/ml Z buffer ONPG, mix well by vortexing, and incubate until sample becomes yellow.
3. Stop reaction by adding 500  $\mu\text{l}$  of 1 M sodium carbonate. Mix well. Measure  $A_{420}$ .

*To permit determination of the actual amount of lacZ protein ( $\beta$ -galactosidase) produced in the cell lysate, a standard curve should be prepared using purified  $\beta$ -galactosidase (a series of concentrations ranging from 0.2 to 50 ng  $\beta$ -galactosidase is usually suitable). These samples will generally need to be incubated  $\sim$ 15 min. The exact quantitation will vary with the preparation, but is usually  $\sim$ 1 U/3  $\mu\text{g}$  protein.*

**EXPRESSION OF PROTEIN FROM IN VIVO-PACKAGED  
RECOMBINANT SFV PARTICLES**

Recombinant and helper RNAs are cotransfected into BHK cells. As a result of trans complementation, recombinant RNAs are packaged into SFV particles which are released into the growth medium (Fig. 16.20.2). The virus produced is used to infect cells in culture which are then assayed for expression of the cloned sequences.

**Materials**

- pSFV1, pSFV3, or pSFV3-lacZ vector (GIBCO/BRL; see Fig. 16.20.1)
- pSFV-Helper 2 DNA (GIBCO/BRL; see Fig. 16.20.1)
- BHK-21 cells (ATCC)
- Minimum essential medium (MEM), supplemented
- Phosphate-buffered saline (PBS; Reagents and Solutions)
- $\alpha$ -chymotrypsin solution
- 2 mg/ml aprotinin (Sigma)
- 35-mm tissue culture plate

**NOTE:** All solutions and equipment coming into contact with cells must be sterile, and proper sterile technique should be used accordingly. All incubations are performed in a humidified, 37°C, 5% CO<sub>2</sub> incubator unless otherwise specified.

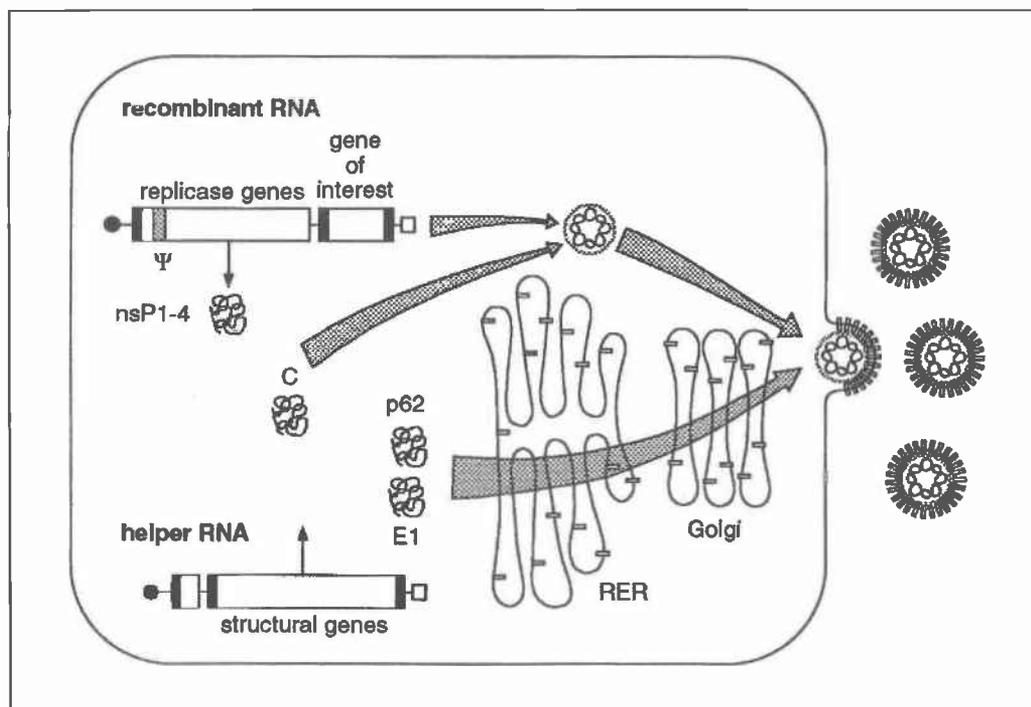

**Figure 16.20.2** Schematic presentation of in vivo packaging of recombinant RNA into SFV particles. Recombinant and helper RNAs are cotransfected into BHK cells, where the recombinant RNA-encoded replicase amplifies both RNA species. The capsid protein (C) packages only recombinant RNA molecules into nucleocapsids, as the helper RNAs lack a packaging signal ( $\Psi$ ; this resides in the *nsP1* gene). Assembly and budding of new recombinant SFV virions occurs at the cell surface through an interaction between cytoplasmically preformed nucleocapsids and the viral spike membrane proteins p62 and E1. Stippled boxes in the recombinant RNA represent packaging signals; black boxes represent replication sequences recognized by the SFV replicase; black circles at the 5' ends of the RNAs denote cap structures; and open boxes at the 3' ends of the RNAs denote poly-A stretches.

### ***Package recombinant RNA into pSFV***

1. Subclone DNA fragment of interest into pSFV plasmid. Prepare RNA by in vitro transcription from the recombinant pSFV plasmid and the pSFV-Helper 2 plasmid using the procedure described in steps 1 to 4 of the first basic protocol.
2. Mix the two RNAs in a 1:1 molar ratio. Transfect RNA mixture into BHK-21 cells as described in steps 5 to 12 of the first basic protocol or steps 5 to 9 of the alternate protocol. Incubate 24 hr.

*In practice, equal amounts (usually 10  $\mu$ l each) of the two transcription mixtures or purified RNAs can be used, because the transcription mixture was set up to contain a saturated amount of DNA (and thus promoter copies). Deviations from a 1:1 ratio will lead to lower stock titers.*

3. Collect the medium and clarify by centrifuging 15 min at  $2000 \times g$  in a tabletop centrifuge at  $4^{\circ}\text{C}$ .
4. Aliquot and freeze 0.5-ml aliquots quickly on dry ice or in liquid nitrogen. Store at  $-80^{\circ}\text{C}$ . Titrate one aliquot as described in the third support protocol.

*At this stage virus can also be purified and/or concentrated (fourth support protocol).*

### ***Infect cells with SFV***

5. Grow fresh BHK-21 cells to 80% to 100% confluency on a 35-mm tissue culture plate.
6. Aspirate medium and wash cells thoroughly with PBS.

### ***Activate Helper 2-packaged recombinant virus***

7. Add  $\frac{1}{20}$  vol  $\alpha$ -chymotrypsin solution to virus preparation and incubate 30 min at room temperature.
8. Inactivate  $\alpha$ -chymotrypsin by adding 0.5 vol aprotinin.
9. Dilute activated virus preparation as appropriate in supplemented MEM using a multiplicity of infection of five. Transfer solution to ice.

*Activation should be done just before infection, as the activated stock cannot be stored frozen or for longer periods of time on ice.*

10. Add 500  $\mu$ l of the virus solution to the cells and incubate 45 min to 1 hr.
11. Remove virus solution, add 3 ml complete BHK-21 medium (or other suitable medium required for the experiment), and continue incubation as required.
12. Prepare cell lysates and analyze protein expression as described in steps 17 to 19 of the first basic protocol.

## **DETERMINATION OF RECOMBINANT VIRUS TITER**

The recombinant virus can initiate only one round of intracellular replication. Therefore, the titer of the packaged stock cannot be determined by conventional plaque assay, but is done using indirect immunofluorescence. Different dilutions of the virus stock are used to infect cells and heterologous protein expression is detected by specific antibodies.

### ***Materials***

- Recombinant virus stock (second basic protocol)
- PBS-Eisen
- Methanol,  $-20^{\circ}\text{C}$
- Blocking buffer: 0.5% (w/v) gelatin/0.2% (w/v) BSA in PBS-Eisen

**SUPPORT  
PROTOCOL**

**Protein  
Expression**

**16.20.9**

Primary antibody in blocking buffer  
Secondary antibody in blocking buffer  
Moviol 4-88 solution containing 2.5% DABCO (1,4-diazobicyclo-[2.2.2]-octane)  
Glass coverslips  
Additional reagents and equipment for immunofluorescent labeling of monolayer cells (UNIT 14.6)

1. Grow BHK-21 cells on glass coverslips to ~70% confluency and count with a hemacytometer to determine number of cells plated.
2. Activate virus stock as in steps 7 to 10 of second basic protocol and prepare a series of dilutions in supplemented MEM. Infect the cells as described in the second basic protocol, steps 5 and 6. Incubate 7 to 15 hr to allow for expression of the protein of interest.

*A good initial dilution series is 1:10, 1:100, and 1:1000 (Critical Parameters, UNIT 14.6).*

3. Rinse each coverslip twice with PBS-Eisen to cover. Fix cells 5 min in  $-20^{\circ}\text{C}$  methanol for 5 min.
4. Remove methanol and wash coverslip three times with PBS.
5. Add blocking buffer and incubate 30 min at room temperature to block nonspecific binding.
6. Replace blocking buffer with primary antibody solution. Incubate 30 min at room temperature.
7. Wash three times with PBS. Repeat step 6 using secondary antibody solution.
8. Wash three times with PBS and once with water. Drain and allow coverslip to air dry.
9. Mount coverslip on glass slide using 10 to 20  $\mu\text{l}$  Moviol 4-88 solution containing 2.5% DABCO. Carry out immunofluorescent staining, count cells, and calculate the percentage of cells expressing the protein of interest.

*For example, if  $10^6$  cells were plated, and 1% are observed expressing protein, then the viral titer is  $10^4$  per coverslip. This value should then be multiplied by the dilution factor to obtain the true titer.*

*DABCO reduces the fading of FITC.*

## SUPPORT PROTOCOL

### PURIFICATION OF SFV PARTICLES

To concentrate or purify the recombinant virus from the medium, the particles are sedimented by ultracentrifugation onto a sucrose cushion.

#### *Additional Materials*

Transfected BHK-21 cells (first basic protocol, step 12)  
20% (w/v) and 55% (w/v) sucrose in TNE buffer  
TNE buffer  
Beckman SW-40 or SW-41 centrifuge tubes and rotor, or equivalent

1. Centrifuge medium from transfected BHK-21 cells 15 min at  $2000 \times g$  in a tabletop centrifuge at  $4^{\circ}\text{C}$  to separate growth medium from remaining cells and cell debris.
2. Set up a step gradient consisting of 1 ml of 55% sucrose and 3 ml of 20% sucrose in an SW-40 or SW-41 ultracentrifuge tube. Layer cleared medium on top of gradient (9 ml for a SW-40 tube or 8 ml for a SW-41 tube). Centrifuge 90 min at 30,000 rpm

( $\sim 160,000 \times g$ ) in a Beckman SW-40 or SW-41 rotor to sediment the virus onto the 55% cushion (see also *UNIT 5.3*).

3. Aspirate top fraction containing medium and remove (from above) 0.8 ml of the 55% sucrose from the bottom of the tube. Collect the virus band from the bottom of the tube in a total volume of 1 ml. Divide band into 50- to 100- $\mu$ l aliquots, diluting 1:2 or more with TNE buffer if desired. Quickly freeze on dry ice or in liquid nitrogen and store at  $-80^{\circ}\text{C}$ .

*Aliquoting is recommended because repeated freezing and thawing can markedly reduce the infectivity of the virus preparation.*

## REAGENTS AND SOLUTIONS

### *$\alpha$ -chymotrypsin solution*

Prepare in PBS (see recipe):

10 mM  $\text{MgCl}_2$

20 mM  $\text{CaCl}_2$

10 mg/ml  $\alpha$ -chymotrypsin

Store several months at  $-20^{\circ}\text{C}$

### *Chase medium*

MEM (GIBCO/BRL)

2 mM glutamine

20 mM HEPES

150  $\mu$ g/ml methionine

Store  $\leq 1$  month at  $4^{\circ}\text{C}$

### *Complete BHK-21 medium*

G-MEM (GIBCO/BRL)

5% (v/v) fetal calf serum

10% (w/v) tryptose phosphate

20 mM HEPES

2 mM glutamine

0.1 U/ml penicillin (optional)

0.1  $\mu$ g/ml streptomycin (optional)

Store  $\leq 1$  month at  $4^{\circ}\text{C}$

### *Minimum essential medium (MEM), supplemented*

Prepare MEM (GIBCO/BRL) containing 0.2% (w/v) BSA, 2 mM glutamine, and 20 mM HEPES. Store  $\leq 1$  month at  $4^{\circ}\text{C}$ .

### *NP-40 lysis buffer*

1% (v/v) Nonidet P-40 (NP-40; from 10% stock)

50 mM Tris-Cl, pH 7.6

150 mM NaCl

2 mM EDTA

Store several months at  $4^{\circ}\text{C}$

**PBS-Eisen**

0.257 g  $\text{NaH}_2\text{PO}_4 \cdot \text{H}_2\text{O}$   
2.250 g  $\text{Na}_2\text{HPO}_4 \cdot 2\text{H}_2\text{O}$   
8.767 g NaCl  
 $\text{H}_2\text{O}$  to 1000 ml  
Store indefinitely at 4°C

**Phosphate-buffered saline (PBS)**

2.68 mM KCl  
1.47 mM  $\text{KH}_2\text{PO}_4$   
136.8 mM NaCl  
8.0 mM  $\text{Na}_2\text{HPO}_4 \cdot 7\text{H}_2\text{O}$   
Adjust pH to 7.0 to 7.2 with HCl  
Autoclave 30 min  
Store indefinitely at 4°C

*PBS is also available commercially (GIBCO/BRL) and other formulations exist (e.g., see APPENDIX 2); however, not all can be successfully used for these protocols. PBS for these applications must be without  $\text{MgCl}_2$  or  $\text{CaCl}_2$ .*

**rNTP mix**

10 mM ATP  
10 mM CTP  
10 mM UTP  
5 mM GTP  
Aliquot and store indefinitely at -20°C

**SP6 RNA polymerase buffer, 10×**

400 mM HEPES-KOH, pH 7.4  
60 mM magnesium acetate  
20 mM spermidine-HCl  
Store indefinitely at -20°C

**Starvation medium**

Methionine-free MEM (GIBCO/BRL)  
2 mM glutamine  
20 mM HEPES  
Store  $\leq 1$  month at 4°C

**TD solution, 5×**

20% (w/v) Ficoll 400  
25 mM EDTA, pH 8.0  
0.05% (w/v) bromphenol blue  
0.03% (w/v) xylene cyanol  
Store several months at 4°C

**TNE buffer**

50 mM Tris-Cl, pH 7.4  
100 mM NaCl  
0.5 mM EDTA  
Store indefinitely at room temperature

### **Xgal stain solution**

Prepare in PBS:

5 mM  $K_4Fe(CN)_6 \cdot 3H_2O$  (potassium ferrocyanide)

5 mM  $K_3Fe(CN)_6$  (potassium ferricyanide)

2 mM  $MgCl_2$

Store several months at 4°C

Just before use, add Xgal (5-bromo-4-chloro-3-indolyl- $\beta$ -D-galactopyranoside; dimethylformamide stock) to 1 mg/ml.

**CAUTION:** Avoid coming into contact with or inhaling cyanide and discard waste using appropriate precautions.

*This recipe is based on Sanes et al. (1986); see also UNIT 9.11 for further discussion.*

### **Z buffer**

60 mM  $Na_2HPO_4$

40 mM  $NaH_2PO_4$

10 mM KCl

1 mM  $MgSO_4$

40 mM 2-mercaptoethanol (2-ME)

Store  $\leq 1$  month at 4°C

## **COMMENTARY**

### **Background Information**

**Alphavirus replication.** Alphaviruses such as Semliki Forest virus (SFV) are small-enveloped viruses with single-stranded RNA genomes of positive polarity that replicate in virtually all animal cells. Upon infection, the 5' end of the viral genome is used for translation of four nonstructural proteins (*nsP1-4*). These are responsible for the production of genome-length negative strands, which are subsequently used for production of new positive-strand genomes as well as a smaller subgenome species. The latter corresponds to the last one-third of the viral genome and is used as the mRNA for virus structural proteins—i.e., the capsid protein, C, and the two membrane proteins, p62 and E1 (Schlesinger and Schlesinger, 1990). The C protein complexes with new viral genomes to form cytoplasmic nucleocapsid structures, while the two membrane proteins are translocated into the endoplasmic reticulum to form heterodimers; these heterodimers are routed to the cell surface, where virus budding occurs. The membrane-protein spikes mediate virus binding and uptake into new host cells by receptor-mediated endocytosis. Inside the endosomes, the acidic milieu induces structural changes in the spike protein, thereby inducing fusion of the viral and endosomal membranes. This results in release of the nucleocapsid with the viral genome into the cell cytoplasm (Bron et al., 1992; Garoff et al., 1990; Liljeström and Garoff, 1991a; Lobigs and Garoff, 1990;

Lobigs et al., 1990a, b; Salminen et al., 1992; Suomalainen et al., 1992; Wahlberg and Garoff, 1992; Wahlberg et al., 1989, 1992).

**Alphaviruses as expression vectors.** Several different alphavirus genomes have recently been cloned as cDNAs and used to produce infectious RNA by in vitro transcription (Davis et al., 1989; Kuhn et al., 1991; Liljeström et al., 1991; Rice et al., 1987). The SFV and Sindbis cDNAs have been further developed into general expression systems for insertion of foreign DNA in place of the viral structural genes (Bredenbeek and Rice, 1992; Liljeström, 1993; Liljeström and Garoff, 1991b; Rice, 1992; Xiong et al., 1989). The basic difference between the two systems is the type of helper used. The Sindbis system uses a helper vector containing the sequence of a Sindbis DI (defective interfering) particle, and therefore contains an RNA packaging signal. When cotransfected with Sindbis recombinant RNA into host cells, the DI-helper RNA provides structural proteins for packaging of both the recombinant genome and the DI genome into virus particles. A mixed DI/recombinant virus stock is obtained after amplification through several passages. In contrast, the SFV system uses a helper construct which, although coding for the structural proteins, cannot itself be packaged due to the lack of a proper RNA packaging signal. Its use together with SFV recombinant RNA results in production of a virus stock that contains only recombinant virus genomes; therefore,

vector structural proteins are not produced when cells are infected by these particles. High-efficiency transfection conditions such as electroporation permit the generation of a high-titer recombinant SFV stock.

#### *Advantages of the SFV expression system.*

In comparison to those of other expression systems, the SFV replication cycle exhibits many features that are advantageous for the practical performance of the expression system. (1) Extremely high levels of production can be obtained because the heterologous gene is expressed using the viral RNA replication and translation signals. (2) Recombinant RNA molecules are expressed in the host cell cytoplasm. The virus *nsp* region encodes the machinery required for RNA replication as well as capping of the 5' ends, thereby circumventing many problems that may occur in nuclear gene expression (such as limitation of transcription factors and problems with RNA splicing or RNA transport). (3) The system is very fast and easy to use, employing standard plasmid subcloning techniques. A high-titer recombinant virus stock can be produced by a single passage in electroporated cells, without need for tedious amplification or selection procedures. (4) The recombinant virus stock does not include any helper virus, and thus there is no interference of coexpressed virus structural proteins with the heterologous gene product when the stock is used in expression studies. (5) SFV has a very wide natural host range. Consequently, virus particles produced by the SFV expression system are capable of delivering a heterologous gene into probably any higher eukaryotic tissue culture cell type used today. (6) Cell morphology is preserved. Although use of the SFV expression system eventually leads to cell death, there is a variable but considerable time lag before morphological changes begin to occur (10 to 20 hr depending on the host cell line). In particular, this expression system can be used in epithelial cell cultures (MDCK) and primary neuronal cells (rat ganglion cells) within these incubation time spans without loss of differentiated morphological features.

#### **Critical Parameters**

**Transfection efficiency.** The success of the SFV expression system is highly dependent on the RNA transfection efficiency. Practically all BHK cells can be transfected using the conditions described in the electroporation protocol. Similar results can probably be obtained in other cell types if transfection efficiency is

optimized as function of voltage, capacitance, time constant of electrical pulse, and number of pulses (see *UNITS 9.3 & 9.9*). Under optimal conditions, transfection with Lipofectin also gives good results. Although Lipofectin can be used with a wide variety of cells, the exact optimal conditions may vary slightly. Parameters to consider are final amounts of lipid and RNA, lipid:RNA ratio, and time of lipid-RNA administration (see *UNITS 9.4 & 9.9*, detailing liposome-mediated transfection with DNA, for further discussion of Lipofectin). For in vitro expression of the recombinant protein, an important consideration is the quality of the RNA preparation (see *Critical Parameters in UNIT 10.17*).

**Virus particle formation.** Another factor of importance is the ability of a given cell type to support virus particle formation. This can be checked using wild-type SFV. Recombinant virus stock should be aliquoted and stored at  $-80^{\circ}\text{C}$  after quick freezing in dry ice or liquid nitrogen. Original culture supernatant or step gradient-purified virus can be stored in this fashion. Repeated freezing and thawing should be avoided, as it reduces virus infectivity; pelleting of the virus is not recommended, as it also may lead to considerable (10- to 100-fold) reduction in infectivity.

**Safety considerations.** When using the original pSFV-Helper 1 and recombinant RNA for virus stock preparation, recombination (strand-switching by the replicase) of the RNA species may occur (Geigenmüller-Gnirke et al., 1991; Weiss and Schlesinger, 1991). It is estimated that the frequency of recombinant particles found in one packaging mixture is  $\sim 10^{-6}$  (i.e.,  $\leq 10^3$  spreading competent SFV particles). Although this would be of little importance for the outcome of an expression experiment involving, for instance,  $10^6$  cells infected with 5 infectious units (IU) per cell, the existence of such particles constitutes a potential biosafety risk. Therefore, a new vector, pSFV-Helper 2, was designed for use in producing conditionally infectious particles (Berglund et al., 1993). These particles must be activated by chymotrypsin treatment to become infectious. Due to the design of the new Helper system, no replication-proficient virus has been found. The new Helper has been approved by the NIH Recombinant DNA Advisory Committee for use at Biosafety Level-2 (BL-2).

#### **Anticipated Results**

In general,  $10^7$  BHK cells should yield  $\sim 10^9$  to  $10^{10}$  infectious recombinant particles when

cotransfected with recombinant and pSFV-Helper 2 RNA and incubated for 24 hr. In cells transfected with ~5 IU/cell, after ~4 hr of incubation the majority of newly synthesized polypeptide chains should represent heterologous protein products, meaning that the labeled heterologous protein should be seen as the major band on SDS gel analysis and autoradiography. After 20 to 25 hr of incubation the heterologous protein product should be the predominant protein in the cell, and Coomassie brilliant blue staining of the SDS gel should reveal the heterologous protein as a major band.

### Time Considerations

Recombinant RNA can be used directly for phenotype analysis in cells after transfection. In this case phenotype analysis can be done after only a 4-hr incubation. Stock virus preparation requires 24-hr incubation of cotransfected cells. The supernatant can then be used directly for infection-mediated gene transduction into new hosts.

### Literature Cited

- Berglund, P., Sjöberg, M., Garoff, H., Atkins, G.J., Sheahan, B.J., and Liljeström, P. 1993. SFV expression system: Production of conditionally infectious recombinant particles. *BioTechnology* 11:916-920.
- Bredenbeek, P.J. and Rice, C.M. 1992. Animal RNA virus expression systems. *Semin. Virol.* 3:297-310.
- Bron, R., Wahlberg, J.M., Garoff, H., and Wilschut, J. 1992. Membrane fusion of Semliki Forest virus in a model system: Correlation between fusion kinetics and structural changes in the envelope glycoprotein. *EMBO J.* 12:693-701.
- Davis, N.L., Willis, L.V., Smith, J.F., and Johnston, R.E. 1989. In vitro synthesis of infectious Venezuelan Equine Encephalitis virus RNA from a cDNA clone: Analysis of a viable deletion mutant. *Virology* 171:189-204.
- Garoff, H., Huylebroeck, D., Robinson, A., Tillman, U., and Liljeström, P. 1990. The signal sequence of the p62 protein of Semliki Forest virus is involved in initiation but not in completing chain translocation. *J. Cell Biol.* 111:867-876.
- Geigenmüller-Gnirke, U., Weiss, B., Wright, R., and Schlesinger, S. 1991. Complementation between Sindbis viral RNAs produces infectious particles with a bipartite genome. *Proc. Natl. Acad. Sci. U.S.A.* 88:3253-3257.
- Kuhn, R.J., Niesters, H.G.M., Hong, Z., and Strauss, J.H. 1991. Infectious RNA transcripts from Ross River virus cDNA clones and the construction and characterization of defined chimeras with Sindbis virus. *Virology* 182:430-441.
- Liljeström, P. 1993. Virally based transient expression systems. *Curr. Opin. Ther. Pat.* 3:375-402.
- Liljeström, P. and Garoff, H. 1991a. Internally located cleavable signal sequences direct the formation of Semliki Forest virus membrane proteins from a polyprotein precursor. *J. Virol.* 65:147-154.
- Liljeström, P. and Garoff, H. 1991b. A new generation of animal cell expression vectors based on the Semliki Forest virus replicon. *BioTechnology* 9:1356-1361.
- Liljeström, P., Lusa, S., Huylebroeck, D., and Garoff, H. 1991. In vitro mutagenesis of a full-length cDNA clone of Semliki Forest virus: The 6000-molecular-weight membrane protein modulates virus release. *J. Virol.* 65:4107-4113.
- Lobigs, M. and Garoff, H. 1990. Fusion function of the Semliki Forest virus spike is activated by proteolytic cleavage of the envelope glycoprotein p62. *J. Virol.* 64:1233-1240.
- Lobigs, M., Wahlberg, J.M., and Garoff, H. 1990a. Spike protein oligomerization control of Semliki Forest virus fusion. *J. Virol.* 64:5214-5218.
- Lobigs, M., Zhao, H., and Garoff, H. 1990b. Function of Semliki Forest virus E3 peptide in virus assembly: Replacement of E3 with an artificial signal peptide abolishes spike heterodimerization and surface expression of E1. *J. Virol.* 64:4346-4355.
- Rice, C.M. 1992. Examples of expression systems based on animal RNA viruses: Alphaviruses and influenza virus. *Curr. Opin. Biotechnol.* 3:522-532.
- Rice, C.M., Levis, R., Strauss, J.H., and Huang, H.V. 1987. Production of infectious RNA transcripts from Sindbis virus cDNA clones: Mapping of lethal mutations, rescue of a temperature-sensitive marker, and in vitro mutagenesis to generate defined mutants. *J. Virol.* 61:3809-3819.
- Salminen, A., Wahlberg, J.M., Lobigs, M., Liljeström, P., and Garoff, H. 1992. Membrane fusion process of Semliki Forest virus II: Cleavage dependent reorganization of the spike protein complex controls virus entry. *J. Cell Biol.* 116:349-357.
- Sanes, J., Rubenstein, J.L.R., and Nicolas, J.-F. 1986. Use of recombinant retrovirus to study post-implantation cell lineage in mouse embryos. *EMBO J.* 5:3133-3142.
- Schlesinger, S. and Schlesinger, M.J. 1990. Replication of Togaviridae and Flaviviridae. In *Virology* (B.N. Fields and D.M. Knipe, eds.) pp. 697-711. Raven Press, N.Y.
- Suomalainen, M., Liljeström, P., and Garoff, H. 1992. Spike protein-nucleocapsid interactions drive the budding of alphaviruses. *J. Virol.* 66:4737-4747.
- Wahlberg, J. and Garoff, H. 1992. Membrane fusion process of Semliki Forest virus I: Low pH-induced rearrangement in spike protein quaternary structure precedes virus penetration into cells. *J. Cell Biol.* 116:339-357.

- Wahlberg, J.M., Boere, W.A., and Garoff, H. 1989. The heterodimeric association between the membrane proteins of Semliki Forest virus changes its sensitivity to mildly acidic pH during virus maturation. *J. Virol.* 63:4991-4997.
- Wahlberg, J.M., Bron, R., Wilschut, J., and Garoff, H. 1992. Membrane fusion of Semliki Forest virus involves homotrimers of the fusion protein. *J. Virol.* 66:7309-7318.
- Weiss, B.G. and Schlesinger, S. 1991. Recombination between Sindbis virus RNAs. *J. Virol.* 65:4017-4025.
- Xiong, C., Levis, R., Shen, P., Schlesinger, S., Rice, C.M., and Huang, H.V. 1989. Sindbis virus: An efficient, broad host range vector for gene expression in animal cells. *Science (Wash. DC)* 243:1188-1191.

## Key References

- Liljeström et al., 1991. See above.  
*Describes construction of a cDNA clone of the SFV genome, which was a basis for the SFV expression vectors.*
- Liljeström and Garoff, 1991b. See above.  
*Describes use of SFV vectors to express various proteins.*
- Berglund et al., 1993. See above.  
*Describes use of a second-generation Helper vector for producing conditionally infectious recombinant SFV particles.*

---

Contributed by Peter Liljeström and  
Henrik Garoff  
Karolinska Institute, Novum Research Center  
Huddinge, Sweden

## Inducible Gene Expression Using an Autoregulatory, Tetracycline-Controlled System

Tetracycline-regulated gene expression systems have been developed to overcome some of the obstacles encountered using other strategies for inducible gene expression in mammalian cells. These difficulties include pleiotropic, nonspecific effects or toxicity of inducing agents or treatments, and high uninduced background levels of expression. This unit describes protocols for using a modified tetracycline-regulated system in which a transcriptional transactivator drives expression of itself and a target gene in cultured cells and, to some extent, in transgenic mice. This transactivator (tTA) is a fusion protein consisting of the tetracycline-repressor of *E. coli* and the transcriptional activation domain of the VP16 protein of herpes simplex virus. In the absence of tetracycline, tTA binds to and activates genes preceded by a heptamerized version of the tetracycline-resistance operator of *Tn10* plus a minimal CMV promoter (here collectively referred to as Tet P). Binding of tTA to Tet P and subsequent gene activation are blocked in the presence of tetracycline. The plasmid pTet-Splice (Fig. 16.21.1A) contains Tet P upstream, and SV40 splice and polyadenylation signals downstream, of a multiple cloning site into which sequences encoding the open reading frame (ORF) of a target gene of choice is easily inserted. Autoregulatory tTA expression is driven from the plasmid pTet-tTAK (Fig. 16.21.1B), in which the tTA ORF (including an optimal sequence for initiation of translation according to Kozak) has been inserted into pTet-Splice.

The protocols in this unit describe the transfection of adherent cells and the testing of resultant clones for inducible transactivator or target gene protein expression. Stably transfected fibroblast cell lines expressing transactivator and target gene(s) can be derived by first cotransfecting pTet-tTAK and a plasmid encoding a selectable marker and obtaining stable lines with inducible transactivator expression (see Basic Protocol). These lines are subsequently stably cotransfected with plasmids encoding the target gene(s) and a second selectable marker. The procedure may also be used to cotransfect pTet-tTAK with the target gene-encoding plasmid(s) and a single selectable marker plasmid. The choice of method depends upon the feasibility of screening for the protein products of the target genes. While the consecutive method is more systematic, cotransfection may be faster given a relatively straightforward screening method for expression of the target gene (see Critical Parameters).

A Support Protocol also describes methods to test stably transfected cell lines for inducible gene expression, for transient transfection and induction of tet-regulated plasmids, and for detection of the tTAK gene in cells (or transgenic mice).

### CALCIUM PHOSPHATE-MEDIATED STABLE TRANSFECTION OF NIH3T3 CELLS WITH pTet-tTAK AND TETRACYCLINE-REGULATED TARGET PLASMIDS

#### BASIC PROTOCOL

This protocol describes the stable transfection of adherent cells with pTet-tTAK for the derivation of cell lines expressing inducible tTA. In the first round of transfection stable cell lines expressing inducible tTA alone are produced. The single transfection procedure may also be used for stable cotransfection of pTet-tTAK and plasmids expressing the target gene(s). In the second round of transfection tTA expressing lines are transfected with plasmids expressing the target gene(s).

#### Protein Expression

### 16.21.1

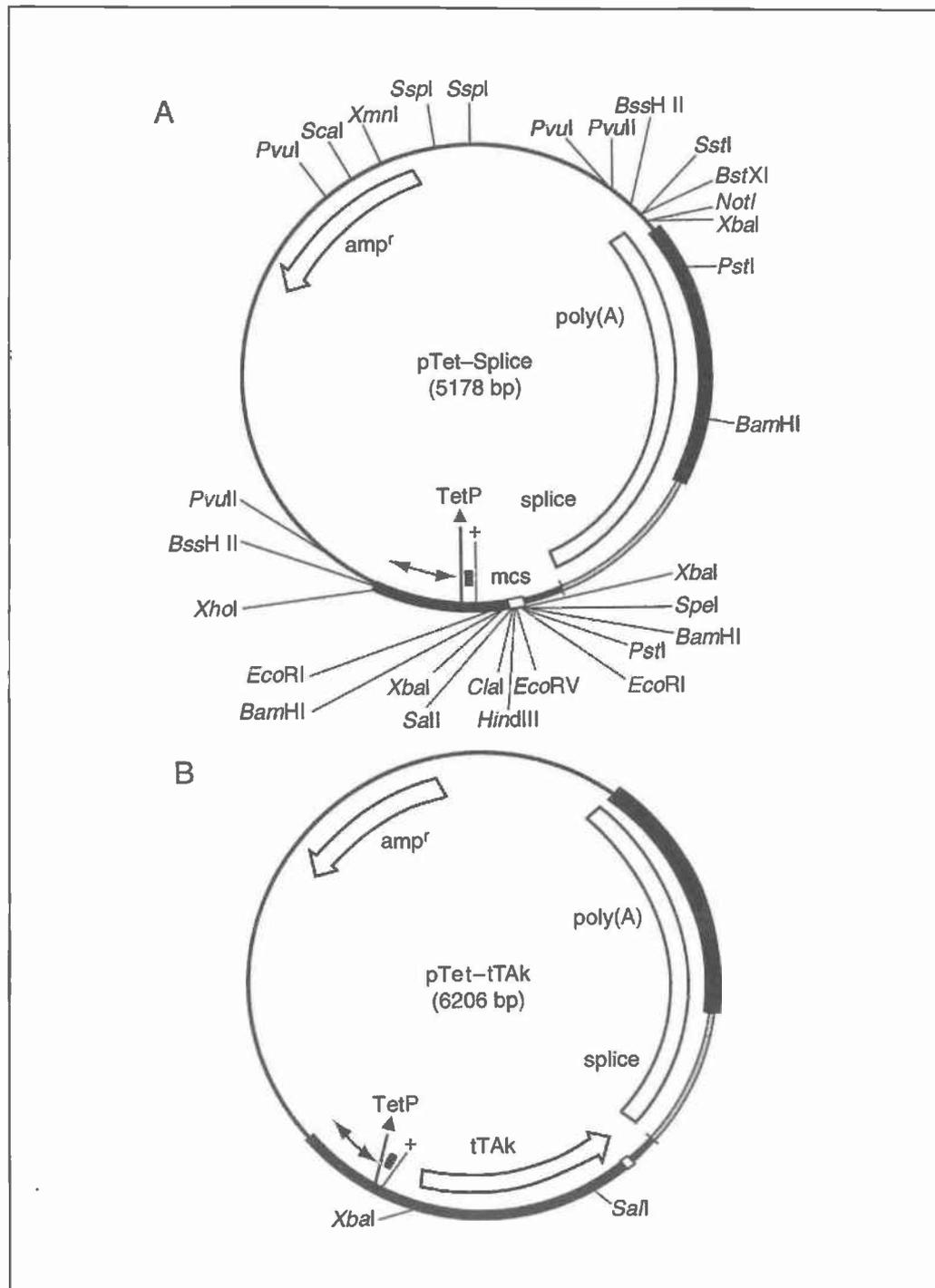

**Figure 16.21.1** (A) The plasmid pTet-Splice (Shockett et al., 1995) is designed to drive tetracycline-regulated expression of a target gene inserted into the multiple cloning site (mcs). The tetracycline-regulated promoter (TetP) consists of a heptamerized tetracycline operator (double-ended arrow) upstream of a minimal human CMV promoter that includes bases -53 (triangle) to +75. The transcriptional start site (+) and TATAA box (small rectangle) are also indicated. This TetP fragment is an *XhoI-SalI* fragment derived from pUHC13-3 (Gossen and Bujard, 1992). SV40-derived sequences downstream of the MCS drive mRNA splicing and polyadenylation. The backbone of the plasmid is from Bluescript II KS+ (Stratagene) and carries the ampicillin resistance gene (*amp<sup>r</sup>*). (B) pTet-tTAk (Shockett et al., 1995) consists of the tTAk open reading frame inserted into the *HindIII-EcoRV* sites of pTet-Splice.

## Materials

NIH3T3 cells

Complete DMEM-10 medium (see recipe)

Complete DMEM/tet: complete DMEM-10 medium (see recipe) containing 0.5  $\mu\text{g/ml}$  tetracycline hydrochloride (Sigma; dilute 10 mg/ml stock in 70% ethanol and store protected from light at  $-20^{\circ}\text{C}$ )

Selection medium (see recipe) containing 125  $\mu\text{M}$ , 250  $\mu\text{M}$ , or 500  $\mu\text{M}$  L-histidinol

Plasmids for first-round or cotransfection procedure: pTet-tTAk (Life Technologies) and plasmids containing target gene ORF(s) cloned into pTet-Splice (Life Technologies), pSV2-His, or another selectable marker plasmid; purified by CsCl banding (UNIT 1.7) or anion-exchange chromatography (UNIT 2.14)

Plasmids for second round transfection procedure: plasmids containing target gene ORF(s) cloned into pTet-Splice, pPGK puro, or another selectable marker plasmid; purified by CsCl banding (UNIT 1.7) or anion-exchange chromatography (UNIT 2.14)

2 M  $\text{CaCl}_2$

HEPES-buffered saline (HeBS; see recipe)

10 mg/ml chloroquine (19 mM; optional; Sigma); dilute in water and store at  $-20^{\circ}\text{C}$

85% HeBS/15% glycerol, prewarmed to  $37^{\circ}\text{C}$

3 mg/ml puromycin (Sigma) diluted in PBS (APPENDIX 2)

Phosphate-buffered saline (PBS; APPENDIX 2)

1 $\times$  trypsin/EDTA (Life Technologies)

10-cm and 6-cm tissue culture plates

4-ml polystyrene tubes (Falcon)

24-well and 6-well tissue culture plates

**NOTE:** All tissue culture incubations are performed in a humidified  $37^{\circ}\text{C}$ , 5%  $\text{CO}_2$  incubator.

## Grow the cells

1. **First round only:** Grow cells in complete DMEM-10 medium. The day before transfection split cells into 10-cm tissue culture plates in complete DMEM/tet to achieve one-third confluence on the day of the transfection.

*From this point on cells are kept in the presence of 0.5  $\mu\text{g/ml}$  tet.*

*One plate per transfection is needed at this stage. A typical experiment might include one plate for tTA only, one for tTA plus target gene, and one to serve as the untransfected control plate.*

**Second round only:** Grow stable cell lines that inducibly express autoregulatory tTA in selection medium/500  $\mu\text{M}$  L-histidinol. The day before transfection split into 10-cm plates in this same medium to achieve one-third confluence on the day of transfection.

## Transfect the cells

2. Linearize plasmids prior to transfection and adjust concentration to  $\geq 0.5$  mg/ml.

*See Damke et al. (1995) for discussion of other selectable markers. All plasmids should be purified by CsCl banding (UNIT 1.7) or on a Qiagen column (UNIT 2.14).*

3. **First round only:** Mix 10 to 20  $\mu\text{g}$  of pTet-tTAk (in the presence or absence of an equimolar amount of target gene plasmids) plus 1 to 2  $\mu\text{g}$  pSV2-His (a molar ratio

of ~10:1 of each tet plasmid to selectable marker plasmid) with 500  $\mu$ l HeBS in a clear 4-ml polystyrene tube.

*A control mock transfection should be performed with no DNA added to the transfection. All of these cells should die in the selection medium/125  $\mu$ M L-histidinol introduced in step 14.*

*Second round only:* Mix 10 to 20  $\mu$ g each of target gene plasmid(s) plus 1 to 2  $\mu$ g pPGKPuro (a molar ratio of ~10:1 of each tet plasmid to selectable marker plasmid) with 500  $\mu$ l HeBS in a clear 4-ml polystyrene tube.

*A control mock transfection should be performed with no DNA added to the transfection. All of these cells should die in the presence of the puromycin introduced in step 14. The optimal killing concentration for puromycin (lowest dose between 0.1  $\mu$ g/ml to 10  $\mu$ g/ml that kills all untransfected cells within a few days) should be determined empirically prior to the transfection and varies with the cell type.*

4. Add 32.5  $\mu$ l of 2 M  $\text{CaCl}_2$  to plasmid DNA and mix immediately by gentle vortexing. With occasional gentle mixing, allow precipitate to form for 15 to 30 min at room temperature or until solution is visibly cloudy when compared to a tube containing water.
5. Aspirate all of the medium from cells, doing one plate at a time. Mix precipitate a few times by pipetting with a Pasteur pipet, and apply dropwise and evenly over cells.
6. Incubate 30 min, gently rocking the plate after 15 min to ensure even coverage over entire plate.
7. *First round only:* Add 10 ml complete DMEM/tet, with or without 25  $\mu$ M chloroquine (final), to each plate.

*Although the use of chloroquine may further reduce cell integrity during the glycerol shock (step 9), it can improve transfection efficiency.*

*Second round only:* Add 10 ml selection medium/500  $\mu$ M L-histidinol, with or without 25  $\mu$ M chloroquine (final), to each plate.

8. Incubate 4 to 5 hr.  
*The optimal length of incubation may vary for different cell types.*
9. Gently aspirate medium from cells with minimal disruption of the precipitate that has settled onto the cells. Shock cells by adding dropwise 2.5 ml of prewarmed 85% HeBS/15% glycerol.

*It is normal for the cells to look somewhat ragged before and especially after glycerol shock. Two to four plates may be shocked at one time, depending on the speed of the researcher.*

10. Aspirate HeBS/glycerol after exactly 2.5 min. Work quickly, as glycerol can be very toxic to the cells.

*The length of time cells are exposed to glycerol solution can be varied and increased up to 4 to 5 min to optimize transfection efficiency for different cell types. Cells should be shocked the maximal length of time which results in the least cell death.*

11. *First round only:* Immediately, gently, and quickly wash cells twice by adding 10 ml complete DMEM/tet and immediately aspirating.

*Because cells tend to come loose from the plate after glycerol addition, add all medium to a single spot on the plate.*

*Second round only:* Immediately, gently, and quickly wash cells twice by adding 10 ml selection medium/500  $\mu$ M L-histidinol and immediately aspirating.

*Again, add medium to a single spot on the plate to avoid loosening the cells.*

12. *First round only:* Add 10 ml complete DMEM/tet. Incubate cells overnight.
- Second round only:* Add 10 ml selection medium/500  $\mu\text{M}$  L-histidinol. Incubate cells overnight.
13. *First round only:* The morning after the transfection, aspirate the medium and replace with 10 ml complete DMEM/tet. Continue incubation.
- Second round only:* The morning after the transfection, aspirate the medium and replace with 10 ml selection medium/500  $\mu\text{M}$  L-histidinol. Continue incubation.

#### **Select and clone transfected cells**

14. *First round only:* At 48 hr posttransfection, split cells into selection medium/125  $\mu\text{M}$  L-histidinol at several dilutions ranging from  $3 \times 10^4$  to  $1 \times 10^6$  cells per 10-cm plate. Make more than one plate in the mid-range that corresponds to an approximate split from one confluent plate of 1:16 to 1:32.

*Second round only:* At 48 hr posttransfection, split cells as above, using selection medium/500  $\mu\text{M}$  L-histidinol containing 3  $\mu\text{g/ml}$  puromycin (final).

*The optimal killing concentration for puromycin (lowest dose between 0.1  $\mu\text{g/ml}$  to 10  $\mu\text{g/ml}$  that kills all untransfected cells within a few days) should be determined empirically prior to the transfection and varies with the cell type. The concentration of 3  $\mu\text{g/ml}$  puromycin is sufficient for selection of transfected NIH3T3 cells.*

15. *First round only:* Refeed cells 4 days later with selection medium/125  $\mu\text{M}$  L-histidinol. When colonies have formed, increase the concentration of L-histidinol in the selection medium to 250  $\mu\text{M}$ .

*L-histidinol is normally toxic to cells. The concentration of L-histidinol in the selection medium is therefore kept low initially and is raised as the number of cells expressing pSV<sub>2</sub>-His at high levels reaches a critical mass.*

*Second round only:* Refeed cells 4 days later with selection medium/500  $\mu\text{M}$  L-histidinol/puromycin.

16. When colonies are well established (at about day 12 to 14 of selection), circle their borders with a marker. Aspirate medium from plate and place a plastic cloning ring (autoclaved upright in vacuum grease) on the plate to surround an individual clone. Wash clones quickly with  $\sim 100 \mu\text{l}$  PBS and add 2 drops of trypsin ( $\sim 100 \mu\text{l}$ ) for 30 sec to 1 min.

*Pick cells from plates on which individual colonies are moderately spaced and can easily be distinguished.*

17. *First round only:* Loosen cells by pipetting up and down with a Pasteur pipet and transfer colonies to wells of a 24-well plate into 1 ml selection medium/250  $\mu\text{M}$  L-histidinol.

*Second round only:* Loosen cells as for first round, transferring them into 1 ml selection medium/500  $\mu\text{M}$  L-histidinol/puromycin.

18. *First round only:* When cells are heavy in wells, split into 6-cm dishes in selection medium/500  $\mu\text{M}$  L-histidinol.

*Second-round only:* When cells are heavy in wells, split into 6-cm dishes in selection medium/500  $\mu\text{M}$  L-histidinol/puromycin.

*All trypsinization is performed by standard methods (APPENDIX 3F), involving a quick PBS wash, a 1 to 3 min trypsin/EDTA incubation (2 ml per confluent 10-cm plate), and using 3rd selection medium/500  $\mu\text{M}$  L-histidinol (+/- puromycin) and containing 10% calf serum to dilute and stop the trypsin.*

19. *First round only:* Expand cells for testing in selection medium/500  $\mu\text{M}$  L-histidinol. Freeze aliquots of cells for storage in liquid nitrogen and grow in selection medium/500  $\mu\text{M}$  L-histidinol from this point on. Test for tTA or target gene expression (if applicable; see Support Protocol for methods that may be used). Or, if applicable, repeat transfection procedure with target gene plasmid(s), following steps 1 to 18 and using the options listed for second-round transfection.

*Second round only:* Test for target gene expression by northern or immunoblotting after induction (see Support Protocol). Freeze aliquots for storage in liquid nitrogen and grow in selection medium/500  $\mu\text{M}$  L-histidinol/puromycin from this point on.

## **ANALYSIS OF TARGET GENE PROTEIN EXPRESSION**

This protocol outlines methods for the analysis of target gene expression and inducibility. Instructions for inducing stable cell lines, for examining transient target gene expression with and without induction, and for PCR amplification of the tTA gene are included, with references to detection procedures such as Southern, northern, and immunoblotting techniques.

### **Induction of Stable Cell Lines**

Stable cell lines can be tested for tTA or target gene expression by comparing induced to uninduced cells for tTA mRNA or target gene mRNA (see Detection of tTA Transgene in Cellular or Tail DNA by Southern Blotting), or protein expression or protein activity. Multiple lines may be screened at a time.

The night before induction, the cells are plated in selection medium/500  $\mu\text{M}$  L-histidinol (see recipe) containing 3  $\mu\text{g}/\text{ml}$  puromycin at an appropriate density such that cells will be subconfluent to confluent at the time of harvest. Cells are washed three times with PBS (APPENDIX 2), with gentle swirling. Immediately, the medium is replaced with selection medium *without* 0.5  $\mu\text{g}/\text{ml}$  tetracycline hydrochloride (tet). (For tet<sup>+</sup> controls, simply aspirate medium and replace with fresh selection medium containing tet.) Cells are incubated 6 to 48 hr in a humidified 37°C, 5% CO<sub>2</sub> incubator, then trypsinized (APPENDIX 3F) and harvested at 4°C, and an aliquot of 0.15–0.4  $\times 10^6$  cells is analyzed by immunoblotting (see UNIT 10.8).

Alternatively, cells may be grown in selection medium in the presence of tet, transferred to tubes [with a quick wash with cold PBS followed by trypsinization (APPENDIX 3F) and stopping of the trypsin by addition of selection medium containing tet], washed three times with PBS (or just pelleted, for tet<sup>+</sup> controls), and replated into selection medium with and without tet at an appropriate density such that the cells will be subconfluent to confluent at the time of harvest.

### **Induction of Gene Expression in Transiently Transfected Cells**

Transient transfection of tet-regulated plasmids is useful in several situations, including the initial testing of the autoregulatory system in a given cell line, screening stable tTA expressors for inducible expression, and biological applications where transient expression is specifically desired.

The night before the transfection, cells are split into medium containing 0.5  $\mu\text{g}/\text{ml}$  tetracycline hydrochloride; the following day they are then transfected by methods appropriate for the cells being used (UNITS 9.1–9.4). Cells are induced by washing them three times in medium without tet. For CaPO<sub>4</sub> transfection, washes are incorporated into those normally performed after glycerol shock (see Basic Protocol, step 11). Uninduced cell

controls are washed with medium containing tet. Medium with and without tet is added to the appropriate plates, then the cells are incubated for 12 to 48 hr in a humidified 37°C, 5% CO<sub>2</sub> incubator. The cells are harvested at 4°C and, if trypsinized (*APPENDIX 3F*), cold medium containing 10% FBS (with and without tet, as appropriate) is used to stop the action of the trypsin. Cells are pelleted for freezing or lysis, and tTA or target gene (experimental or reporter) expression can be analyzed by northern blotting (*UNIT 4.9*), immunoblotting (*UNIT 10.8*), or by an appropriate activity assay (see Commentary).

### Detection of tTA Transgene in Cellular or Tail DNA by PCR

PCR is routinely used to detect the Tet-tTA transgene in candidate transgenic mouse tail DNA. The forward primer derives from the minimal human CMV promoter, CMV-F1:

5'-TGACCTCCATAGAAGACACC-3'

The reverse primer, TTA-REV1, is specific for the tTA ORF:

5'-ATCTCAATGGCTAAGGCGTC-3'

Hot-start PCR (*UNIT 15.1*) is performed on 150 ng of each tail DNA to be analyzed in a reaction mix containing 1.5 mM MgCl<sub>2</sub>, 0.5 μM each primer, and 0.2 mM each dNTP. PCR cycling conditions are as follows:

1 cycle:	3 min	94°C	
		80°C	(pause) add <i>Taq</i> polymerase
30 cycles:	45 sec	94°C	(denaturation)
	45 sec	58°C	(annealing)
	90 sec	72°C	(extension)
1 cycle	10 min	72°C	(extension)
		8°C	(end).

Products are analyzed on a 1% to 1.3% agarose gel; the main product of interest is visible as a 290-bp band after ethidium bromide staining.

### Detection of tTA Transgene in Cellular or Tail DNA by Southern Blotting

The tTA transgene may also be detected by Southern blot analysis (*UNIT 2.9*). Tail DNA is digested with *EcoRI* and blots are probed with a 761-bp *XbaI-SalI* tTA insert from pTet-tTA. This fragment detects a 1094-bp tTA fragment of the transgene. This probe may also be used to detect tTA mRNA by northern blotting (*UNIT 4.9*).

## REAGENTS AND SOLUTIONS

Use deionized, distilled water in all recipes and protocol steps. For common stock solutions, see *APPENDIX 2*; for suppliers, see *APPENDIX 4*.

### Complete DMEM-10

*Dulbecco's minimal essential medium containing:*

- 10% donor bovine calf serum (JRH Biosciences)
- 100 U/ml penicillin/100 μg/ml streptomycin (Life Technologies)
- 2 mM glutamine (Life Technologies)

All DMEM complete medium used in this unit (with or without selection reagents or 0.5 μg/ml tetracycline hydrochloride) may be stored protected from light ~1 month at 4°C).

Fetal bovine serum (FBS) may also be used in place of donor bovine calf serum, but the latter is less expensive.

### ***HEPES-buffered saline (HBS)***

6 mM dextrose  
137 mM NaCl  
5 mM KCl  
0.7 mM Na<sub>2</sub>HPO<sub>4</sub>·7H<sub>2</sub>O  
21 mM HEPES (free acid)  
Adjust final pH to 7.05 with NaOH  
Filter sterilize and store in aliquots at -20°C

### ***Selection medium***

*Complete histidine-free DMEM (Irvine Scientific, purchased without glutamine), containing:*

10% donor bovine calf serum (JRH Biosciences)  
100 U/ml penicillin/100 µg/ml streptomycin (Life Technologies)  
2 mM glutamine (Life Technologies)  
0.5 µg/ml tetracycline·HCl (Sigma; dilute 10 mg/ml stock in 70% ethanol and store protected from light at -20°C)  
125 µM, 250 µM, or 500 µM L-histidinol (Sigma, dilute in water as a 125 mM stock and store at -20°C)

## **COMMENTARY**

### **Background Information**

Inducible, tetracycline-regulated gene expression systems were initially developed to allow the controlled expression in eukaryotic cells of foreign genes not tolerated constitutively in cultured cells or during the development of transgenic animals. The general features of tetracycline-regulated gene expression strategies and their improvements over previous inducible expression systems have been addressed in current review articles (Gossen et al., 1993; Barinaga, 1994; Damke et al., 1995; Shockett and Schatz, 1996). The autoregulatory tTA system used in this protocol derives directly from a constitutive tTA system described by Gossen and Bujard (1992). Although tight regulatory control and high inducibility was achieved with the original system in HeLa cells, the inability to detect clones expressing moderate to high levels of tTA by immunoblotting suggested that the tTA was toxic when expressed constitutively. The autoregulatory tTA system was designed to overcome possible toxic effects of constitutive tTA expression by making tTA expression itself tetracycline regulated. Autoregulated tTA expression theoretically allows for the selection of clones expressing higher levels of tTA via an autoregulatory feed-forward mechanism that is activated only in the absence of tetracycline. In the presence of tetracycline, low-level tTA and target gene expression are driven from the minimal human CMV promoter. However, any tTA produced is

unable to bind to tet operators upstream of the tTA or target gene. Conversely, when tetracycline is removed from the system, the small amounts of tTA protein expressed from the minimal promoter can bind the *tet* operators upstream of the tTA gene, driving higher levels of tTA (for controlled periods of time) and, subsequently, target gene expression.

The theoretical benefits of the autoregulatory tTA system have been confirmed by experiments in stably transfected NIH3T3 cell lines (Shockett et al., 1995). In these experiments, expression of the recombination activating genes *RAG-1* and *RAG-2*, and subsequent DNA recombination activated by these proteins, was higher and more frequently detected among stable transfectants expressing autoregulatory tTA than in constitutive tTA expressors. In transgenic mice expressing a luciferase reporter target transgene, the levels of expression appear to be 1 to 2 orders of magnitude greater with the autoregulatory system, although the uninduced levels also appear to be higher.

Since the description of the early tTA systems, several laboratories have created modified vectors, including streamlined versions containing both tTA and the target gene, viral vectors, and vectors in which expression of two different target genes may be differentially or co-regulated. Some of these systems and their applications have recently been reviewed (Shockett and Schatz, 1996).

## Critical Parameters and Troubleshooting

Cell lines stably expressing both autoregulatory tTA and target genes have been derived at fairly high efficiencies by simultaneous transfection of all plasmids. This method may be faster, but it may require the screening of more clones than if stable lines with low basal and high induced levels of tTA are first derived and subsequently transfected with plasmids encoding the target genes. For the derivation of these clones, any selectable marker combination should theoretically work for consecutive cotransfection. Additionally, although the Basic Protocol describes calcium phosphate-mediated transfection of adherent fibroblast cell lines, the procedure can be adapted for other cell types using their optimal methods of transfection and selection. The protocol can also be scaled down to require fewer cells by using smaller dishes or wells and reducing all components proportionately.

Using the autoregulatory tTA system, tTA mRNA induction appears to be a good indicator of induced tTA expression (see Support Protocol). Alternatively, the vector pUHC13-3 (Life Technologies) encoding luciferase under tet control may be transiently transfected into putative stable tTA expressors as previously described (see Support Protocol and Damke et al., 1995). Cells are then cultured for 12 to 48 hr in the presence and absence of tetracycline. Luciferase activity is easily measured in cell lysates using a kit (Luciferase Assay System and Dual-Luciferase Reporter Assay System; Promega) in which luciferase activity in cell lysates is normalized either to total protein determined using a Bradford protein assay (*UNIT 10.1*), or to a transfection control, respectively. Although basal expression of target plasmids tends to be higher when transiently transfected and luciferase detection is extremely sensitive, this method can be useful for the initial testing of the system in a given cell type (Damke et al., 1995).

It is imperative after stable transfection with pTet-tTA<sub>k</sub> that cells be maintained in medium containing 0.5 µg/ml tetracycline to prevent any toxic effects of tTA expression and subsequent selection against clones expressing high levels of tTA.

## Anticipated Results

In the authors' experience with stably transfected NIH3T3 cells, expression of induced tTA and target gene has been observed by 6 hr

and peaks at ~12 hr after induction. In cells that stably express tTA, transient target gene expression has been observed by 12 hr. In cells transiently expressing tTA and a tet-sensitive luciferase reporter (pUHC13-3), luciferase activity induced by 2 orders of magnitude has been observed by 20 hr.

## Time Considerations

Starting with the plasmid vectors and following the transfection protocols above, stable clones expressing tTA (or tTA + target gene(s) if cotransfecting) are obtained in ~12 to 14 days. Approximately 2 additional weeks are required for expansion and testing of candidate clones. Subsequent transfection of a stable inducible tTA clone with vectors expressing target genes will require the same amount of time. Transient transfection and inducible gene expression may be achieved within 48 hr.

## Literature Cited

- Barinaga, M. 1994. Researchers devise a master gene control switch. *Science* 265:26-28.
- Damke, H., Gossen, M., Freundlieb, S., Bujard, H., and Schmid, S.L. 1995. Tightly regulated and inducible expression of dominant interfering dynamin mutant in stably transformed HeLa cells. *Methods Enzymol.* 257:209-220.
- Gossen, M. and Bujard, H. 1992. Tight control of gene expression in mammalian cells by tetracycline-responsive promoters. *Proc. Natl. Acad. Sci. U.S.A.* 89:5547-5551.
- Gossen, M., Bonin, A.L., and Bujard, H. 1993. Control of gene activity in higher eukaryotic cells by prokaryotic regulatory elements. *Trends Biochem. Sci.* 18:471-475.
- Shockett, P.E. and Schatz, D.G. 1996. Commentary: Diverse strategies for tetracycline-regulated inducible gene expression. *Proc. Natl. Acad. Sci. U.S.A.* 93:5173-5176.
- Shockett, P., Difilippantonio, M., Hellman, N., and Schatz, D. 1995. A modified tetracycline-regulated system provides autoregulatory, inducible gene expression in cultured cells and transgenic mice. *Proc. Natl. Acad. Sci. U.S.A.* 92:6522-6526.

---

Contributed by Penny Shockett  
Yale University School of Medicine  
New Haven, Connecticut

David Schatz  
Howard Hughes Medical Institute and  
Yale University School of Medicine  
New Haven, Connecticut