



US007834605B2

(12) **United States Patent**
Balakrishnan et al.

(10) **Patent No.:** **US 7,834,605 B2**
(45) **Date of Patent:** ***Nov. 16, 2010**

(54) **METHOD AND APPARATUS FOR MAINTAINING A CONSTANT LOAD CURRENT WITH LINE VOLTAGE IN A SWITCH MODE POWER SUPPLY**

(52) **U.S. Cl.** 323/282; 323/273
(58) **Field of Classification Search** 323/282-288, 323/235-239, 220-223, 272-275; 363/79, 363/80, 97, 131, 63, 89
See application file for complete search history.

(75) Inventors: **Balu Balakrishnan**, Saratoga, CA (US); **Alex B. Djenguerian**, Saratoga, CA (US); **Kent Wong**, Fremont, CA (US); **David Michael Hugh Matthews**, Windsor (GB)

(56) **References Cited**

U.S. PATENT DOCUMENTS

3,694,772 A 9/1972 Sordello

(Continued)

FOREIGN PATENT DOCUMENTS

EP 0 744 818 A1 11/1996

(Continued)

OTHER PUBLICATIONS

U.S. Appl. No. 90/009,393, filed Jan. 20, 2009, Power Integrations, Inc.

(Continued)

Primary Examiner—Rajnikant B Patel

(74) *Attorney, Agent, or Firm*—Blakely Sokoloff Taylor & Zafman, LLP

(73) Assignee: **Power Integrations, Inc.**, San Jose, CA (US)

(*) Notice: Subject to any disclaimer, the term of this patent is extended or adjusted under 35 U.S.C. 154(b) by 0 days.

This patent is subject to a terminal disclaimer.

(21) Appl. No.: **12/581,054**

(22) Filed: **Oct. 16, 2009**

(65) **Prior Publication Data**

US 2010/0033147 A1 Feb. 11, 2010

Related U.S. Application Data

(63) Continuation of application No. 11/784,560, filed on Apr. 6, 2007, now Pat. No. 7,646,184, which is a continuation of application No. 11/397,524, filed on Apr. 3, 2006, now Pat. No. 7,215,105, which is a continuation of application No. 10/892,300, filed on Jul. 15, 2004, now Pat. No. 7,110,270, which is a continuation of application No. 10/253,307, filed on Sep. 23, 2002, now Pat. No. 6,781,357.

(60) Provisional application No. 60/325,642, filed on Sep. 27, 2001.

(51) **Int. Cl.**
G05F 1/40

(2006.01)

(57) **ABSTRACT**

A power supply regulator including a variable current limit threshold that increases during an on time of a switch. In one aspect, a power supply regulator includes a comparator that has a first input coupled to sense a voltage representative of a current flowing through a switch during an on time of the switch. The comparator has a second input coupled to receive a variable current limit threshold that increases during the on time of the switch. A feedback circuit is coupled to receive a feedback signal representative of an output voltage at an output of a power supply. A control circuit is coupled to generate a control signal in response to an output of the comparator and in response to an output of the feedback circuit. The control signal is to be coupled to a control terminal of the switch to control switching of the switch.

12 Claims, 5 Drawing Sheets

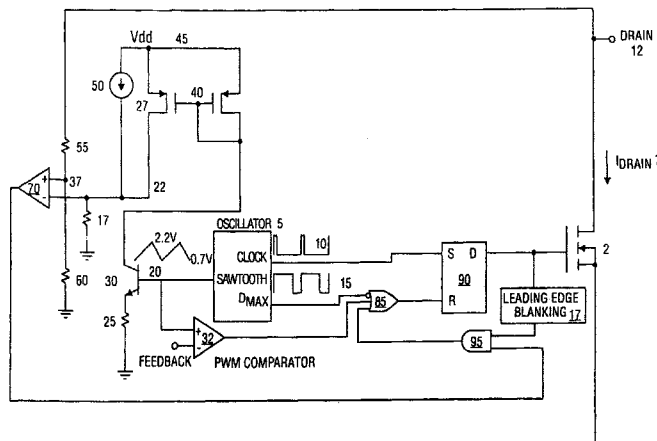

U.S. PATENT DOCUMENTS

4,032,828	A	6/1977	Strobl et al.	
4,357,572	A	11/1982	Andersen et al.	
4,371,824	A	2/1983	Gritter	
4,392,103	A	7/1983	O'Sullivan et al.	
4,674,020	A	6/1987	Hill	
4,764,856	A	8/1988	Rausch	
5,014,178	A	5/1991	Balakrishnan	
5,028,861	A *	7/1991	Pace et al.	323/222
5,045,800	A	9/1991	Kung	
5,170,333	A	12/1992	Niwayama	
5,189,599	A	2/1993	Messman	
5,268,631	A	12/1993	Gorman et al.	
5,285,366	A	2/1994	Zaretsky	
5,313,381	A	5/1994	Balakrishnan	
5,335,162	A	8/1994	Martin-Lopez et al.	
5,465,201	A	11/1995	Cohen	
5,479,090	A	12/1995	Schultz	
5,583,752	A	12/1996	Sugimoto et al.	
5,657,211	A	8/1997	Brockmann	
5,680,034	A *	10/1997	Redl	363/21.03
5,729,120	A	3/1998	Stich et al.	
5,729,443	A	3/1998	Pavlin	
5,995,386	A	11/1999	John et al.	
6,037,674	A	3/2000	Hargedon et al.	
6,154,377	A	11/2000	Balakrishnan et al.	
6,166,521	A	12/2000	Mercer et al.	
6,222,356	B1	4/2001	Taghizadeh-Kaschani	
6,226,190	B1	5/2001	Balakrishnan et al.	
6,233,161	B1	5/2001	Balakrishnan et al.	
6,297,623	B1	10/2001	Balakrishnan et al.	
6,333,624	B1	12/2001	Ball et al.	
6,404,607	B1	6/2002	Burgess et al.	
6,411,119	B1	6/2002	Feldtkeller	
6,498,466	B1	12/2002	Edwards	
6,525,514	B1	2/2003	Balakrishnan et al.	
6,580,593	B2	6/2003	Balakrishnan et al.	
6,583,994	B2	6/2003	Clayton et al.	
6,665,197	B2	12/2003	Gong et al.	
6,674,656	B1	1/2004	Yang et al.	
6,747,443	B2	6/2004	Balakrishnan et al.	
6,781,357	B2	8/2004	Balakrishnan et al.	
6,833,692	B2	12/2004	Balakrishnan et al.	
7,110,270	B2	9/2006	Balakrishnan et al.	

7,215,105	B2	5/2007	Balakrishnan et al.
2007/0182394	A1	8/2007	Balakrishnan et al.

FOREIGN PATENT DOCUMENTS

JP	09-074748	3/1997
----	-----------	--------

OTHER PUBLICATIONS

JP 2002-284064, Notice of the Reason for Refusal (with English Translation), mailed Oct. 21, 2008.
 European Search Report, EP 02256760, Feb. 2, 2005.
 Infineon Technologies Preliminary Datasheet, "ICE2AS01; Off-Line SMPS Current Mode Controller," Datasheet, Version 2.1, Feb. 2001, Infineon Technologies AG, München, Germany.
 National Semiconductor: Linear and Switching Voltage Regulator Fundamentals, *Online: XP002316042 Retrieved from the Internet: URL: <http://web.archive.org/web/20010602192453/http://www.national.com/appinfo/powerfiles/f4.pdf>.
 Linear Technology, LT1375/LT1376, "1.5A, 500kHz Step-Down Switching Regulators," 1995, pp. 1-28.
 Infineon Technologies AG, Edition Apr. 11, 200, "Off-Line Current Mode Controller with CoolMOS™ on board," CoolSET™-F1 TDA 16822, Datasheet, V1.0, Apr. 11, 2000, pp. 1-15.
 Infineon Technologies, "Off-Line Current Mode Controller with CoolMOS™ on board," CoolSET™-F1 TDA 16822, Datasheet, V2.0, Apr. 11, 2000, pp. 1-14.
 TeA 1566 GreenChip™; SMPS Module, Preliminary Specifications, Integrated Circuits, Philips Semiconductors, Apr. 20, 1999, pp. 1-24.
 Paul Horowitz & Winfield Hill, "The Art of Electronics", Second Edition, Published by Cambridge University Press, New York, 1989, Chapter 5, pp. 263-305.
 Analog Devices, "Secondary Side, Off-Line Battery Charger Controllers," ADP3810/ADP3811, Oct. 1996, pp. 1-16.
 Unitrode Integrated Circuits, Title Page, Introduction, and Table of Contents from "Product and Application Handbook 1993-1994," (10 pages).
 Unitrode Integrated Circuits, "Application Note U-100A: The UC3842/3/4/5 Series of Current-Mode PWM IC's," published in "Product and Application Handbook 1994-1995," Jun. 1993, at pp. 9-64 through 9-75; (12 pages).
 Office Action mailed Sep. 24, 2009, Reexamination Control U.S. Appl. No. 90/009,393, filed Jan. 20, 2009.
 Maxim, "How to Design Battery Charger Applications that Require External Microcontrollers and Related System-Level Issues," Application Note 680: <http://www.maxim-ic.com/an680>, Mar. 15, 2000. (16 pages).
 Chester Simpson, "Battery Charging," National Semiconductor, No Available Publication Date. (17 pages).

* cited by examiner

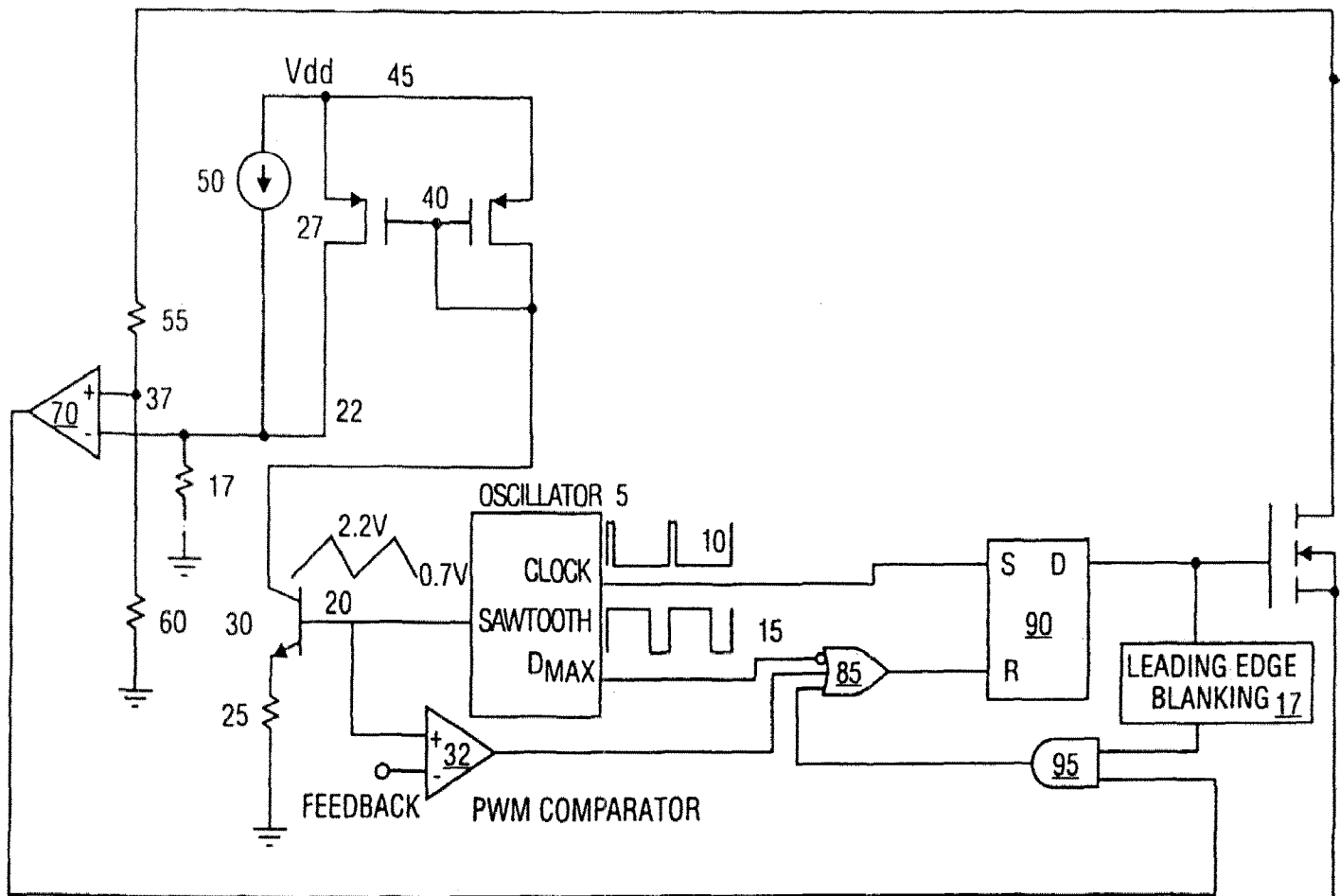

FIG. 1

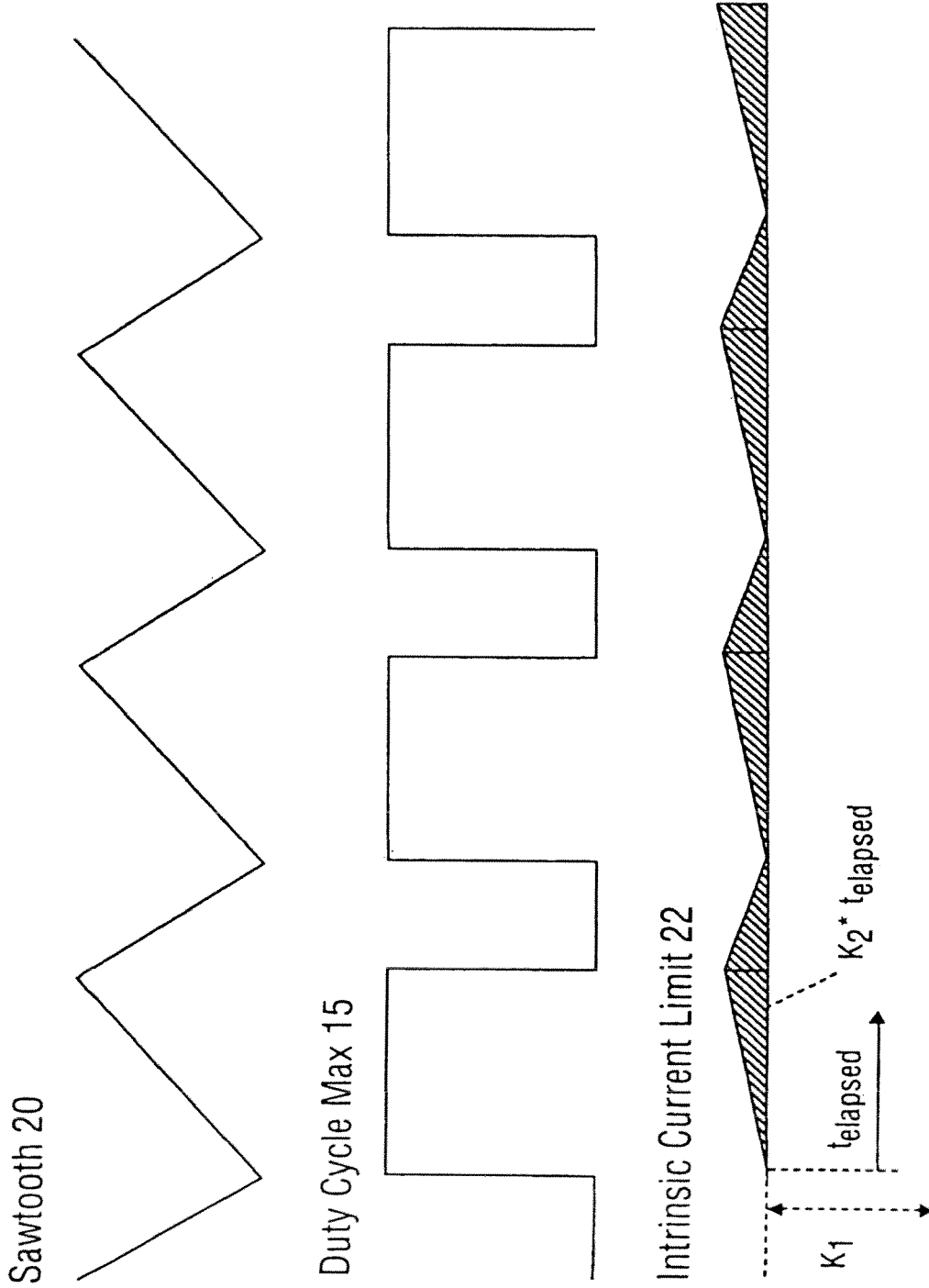

FIG. 2

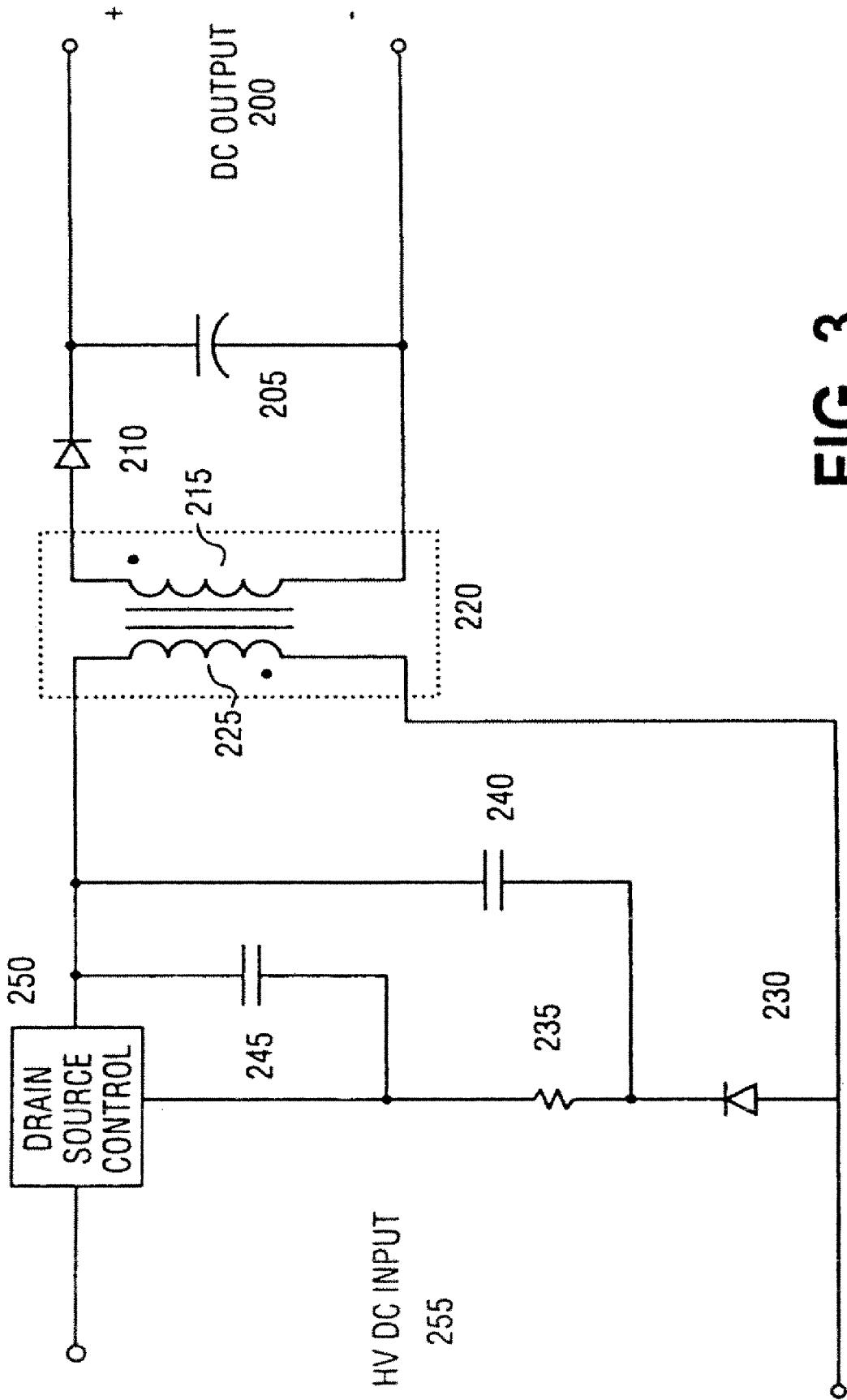

FIG. 3

Explore Litigation Insights

Docket Alarm provides insights to develop a more informed litigation strategy and the peace of mind of knowing you're on top of things.

Real-Time Litigation Alerts



Keep your litigation team up-to-date with **real-time alerts** and advanced team management tools built for the enterprise, all while greatly reducing PACER spend.

Our comprehensive service means we can handle Federal, State, and Administrative courts across the country.

Advanced Docket Research



With over 230 million records, Docket Alarm's cloud-native docket research platform finds what other services can't. Coverage includes Federal, State, plus PTAB, TTAB, ITC and NLRB decisions, all in one place.

Identify arguments that have been successful in the past with full text, pinpoint searching. Link to case law cited within any court document via Fastcase.

Analytics At Your Fingertips



Learn what happened the last time a particular judge, opposing counsel or company faced cases similar to yours.

Advanced out-of-the-box PTAB and TTAB analytics are always at your fingertips.

API

Docket Alarm offers a powerful API (application programming interface) to developers that want to integrate case filings into their apps.

LAW FIRMS

Build custom dashboards for your attorneys and clients with live data direct from the court.

Automate many repetitive legal tasks like conflict checks, document management, and marketing.

FINANCIAL INSTITUTIONS

Litigation and bankruptcy checks for companies and debtors.

E-DISCOVERY AND LEGAL VENDORS

Sync your system to PACER to automate legal marketing.