

(19) Japan Patent Office (JP)

(11) Japanese Unexamined Patent
Application Publication Number

(12) **Japanese Unexamined Patent
Application Publication (A)**

H2-213237

(51) Int. Cl.⁵
H 04 B 7/26

Identification codes
103 A

JPO file number
7608-5K

(43) Publication date: 24 Aug 1990

Request of examination: None Number of claims: 1 (Total of 5 pages)

(54) Title of the invention	MESSAGE TRANSMISSION SYSTEM	
	(21) Application No.: JP H1-32879 A	
	(22) Date of Application: 14 Feb 1989	
(72) Inventor	Akifumi Akiyama	% NTT Corp. 1-1-6 Uchisaiwai-cho, Chiyoda-ku, Tokyo-to
(72) Inventor	Fumiaki Ishino	% NTT Corp. 1-1-6 Uchisaiwai-cho, Chiyoda-ku, Tokyo-to
(72) Inventor	Hideo Sekiguchi	% NTT Corp. 1-1-6 Uchisaiwai-cho, Chiyoda-ku, Tokyo-to
(71) Applicant	NTT Corp.	1-1-6 Uchisaiwai-cho, Chiyoda-ku, Tokyo-to
(74) Agent	Keiichi Yamamoto, patent attorney	

Specification

1. Title of the Invention
2. Claims

A message transmission system comprising a mobile terminal, a wireless base station, and a control station, using one-way wireless communication lines that transmit data from the control station to the mobile terminal via the wireless base station, wherein the data transmitted from the control station is divided into a plurality of frames, a mobile terminal number, a data number, and a frame number are attached to each frame before being transmitted, and transmitted frames are held by the control station for a fixed amount of time,

the mobile terminal checks whether or not the frames were able to be received without error, and, if a frame with an error is identified, stores the data number and the frame number thereof, and visibly displays the data number and the frame number in the mobile terminal,

a mobile terminal owner electrically or acoustically couples the mobile terminal to a general telephone network to transmit to the control station the mobile terminal number, the data number, and the number of the frame where the error occurred,

the control terminal retransmits only the mobile terminal number, the data number, and the error frame number, and

the mobile terminal visibly displays the data of the frames which were initially correctly received and of the retransmitted frame in frame number order.

3. Detailed Description of the Invention
(Industrial Field of Use)

The present invention relates to a one-way mobile wireless data communication system such as a display-type beeper, wherein data is retransmitted when received data is incorrect.

(Prior Art)

Conventionally, in one-way mobile wireless data communication systems, advanced error correction functionality has been added to signals or identical signals have been transmitted multiple times to improve signal reliability. However, these methods involve transmitting data that is several times the length of the actually required data length even when there are no problems in the wireless communication line, wasting valuable wireless bandwidth. The waste is particularly egregious when transmitting identical signals multiple times in cases where long pieces of data are transmitted, such as with display-type beepers. Moreover, mobile communication sometimes involves moving to locations with extremely poor wireless communication line transmission quality, such as inside elevators or tunnels, normally necessitating multiple transmissions even when an advanced error correction symbol is used.

(Problem to be Solved by the Invention)

The present invention has as an object to provide a message transmission system that eliminates the waste of retransmission.

(Means for Solving the Problem)

A feature of the present invention for attaining this object is a message transmission system comprising a mobile terminal, a wireless base station, and a control station, using one-way wireless communication lines that transmit data from the control station to the mobile terminal via the wireless base station, wherein the data transmitted from the control station is divided into a plurality of frames, a mobile terminal number, a data number, and a frame number are attached to each frame before being transmitted, and transmitted frames are held by the control station for a fixed amount of time, the mobile terminal checks whether or not the frames were able to be received without error, and, if a frame with an error is identified, stores the data number and the frame number thereof, and visibly displays the data number and the frame number in the mobile terminal, a mobile terminal holder electrically or acoustically couples the mobile terminal to a general telephone network to transmit to the control station the mobile terminal number, the data number, and the number of the frame where the error occurred, the control terminal retransmits only the mobile terminal number, the data number, and the error frame number, and the mobile terminal visibly displays the data of the frames which were initially correctly received and of the retransmitted frame in frame number order.

The present invention divides data transmitted to a mobile terminal into a plurality of frames, adds a mobile terminal number, a data number, and a frame number to each frame before transmission, and displays the data number and the frame number of an incorrect frame in the mobile terminal, and a mobile terminal owner transmits the data number and the frame number of this incorrect frame over a general telephone line to a control station. The control station holds downlink data for a fixed amount of time and then retransmits only the data numbers and the frame numbers of the incorrect frames to the mobile terminal. Furthermore, if a configuration is used in which the mobile terminal transmits numbers which must be transmitted to the control station, being a control station access number, the mobile terminal number, the incorrect data number, and the frame number, from the mobile terminal to a general telephone network automatically via acoustic coupling or electromagnetic coupling, transmission of these numbers to the control station becomes very easy.

In this manner, when the wireless communication line quality is good, data is only sent once from the control station, and when retransmitting, only incorrect frames are retransmitted, which is very advantageous in terms of efficient use of wireless frequencies.

(Embodiments)

FIG. 1 is one embodiment of the present invention, in which 101 is a mobile terminal, 102 is a base station, 103 is a control station, 104 and 105 are exchanges in a general telephone network, 106 is memory, 107 is a data terminal, and 108 is a telephone.

FIG. 2 shows a frame format of a signal that the control station 103 transmits to the mobile station 101 from the base station 102. 201 is a synchronization signal, 202 is a mobile terminal number, 203 is a data number, 204 is a frame number, 205 is data, and 206 is an error correction detection code.

FIG. 3 is a clock diagram of the mobile terminal, in which 301 is a wireless section, 302 is a control section, 303 is memory, 304 is a display section, 305 is a PB signal generation section, 306 is a speaker, and 307 is keys.

FIG. 4 is a control flow in the mobile terminal. A user wishing to transmit data to the mobile station 101 first dials an access number to the control station 103 from the data terminal 107 using a general telephone line. The exchange 105 extends a communication line to the exchange 104 and is connected to the control station 103. A reception tone is transmitted to the data terminal 107 from the control station 103, and a mobile terminal number that is to be called and data are transmitted from the data terminal 107. Having received these, the control station 103 looks at the length of the received data and if it is larger than an amount the control station 103 can transmit at one time, the control station 103 divides the received data into a plurality of instances of data and transmits this over a wireless communication line. FIG. 2 shows a transmission frame format. Each frame comprises the synchronization signal 201 for establishing frame synchronization and bit synchronization, the mobile terminal number 202 from which data is to be received, the data number 203 that is to be sent, a frame number 204 of the divided data, the divided data 205, and an error correction detection code 206. The control station outputs these data and stores the data that has been transmitted, the mobile terminal number, the data number, the frame number, and the transmitted data in the memory 106. The transmission data is sent from the base station 102 to the mobile station 101 over the wireless communication line. In the mobile station 101, the wireless section 301 in

FIG. 3 performs reception and demodulation (400 in FIG. 4), and the control section 302 corrects any

using the error correction detection code 206 (402). If it is found that there are no errors, the data number 203, the frame number 204, and the data 205 are stored in the memory 303 (404). If there are errors, a symbol is attached indicating that there is an error, and this is similarly stored in the memory 303. Once all the frames in one data number have been received, the control section 302 emits a ring tone (408) as needed, and displays the data to the display section 304 (410). Whether all the frames have been received or not can easily be established by including a number indicating an order of frames and how many frames have been transmitted in the frame number. If there are any frames that contain errors in the display data, the fact that there is an error is also displayed. For the error display, several methods are conceivable, including displaying everything including the incorrect data, and causing the frames with incorrect data to blink, indicating through writing or the like that there are incorrect frames without displaying the data, and so on. The mobile terminal owner sees these displays and if he or she desires to receive correct data, he or she goes to a nearby telephone 108 as in FIG. 1, and if the telephone is a PB telephone, the mobile terminal owner picks up the handset and checks for a dial tone, and then places the speaker section 306 of the mobile terminal 101 against a mouthpiece of the telephone and presses a connection key of the keys 307 (416). The control section 302 reads a connection telephone number to the control station 103 in FIG. 1 from the memory 303, drives the PB signal generation section 305, and transmits the telephone number as a dial signal through the speaker 306 (418). The exchange 105 receives this signal, and causes the control station 103 to receive it via the exchange 104. The control station 103 responds to the call and transmits a talkie or a second dial tone. Upon hearing this, the mobile terminal owner presses the data transmission key in the keys 307 (420), upon which the control section 302 reads the data number, the frame number, and its own mobile terminal number for the data that is experiencing the error from the memory 303, drives the PB signal generation section 305, and transmits the data through the speaker 306 (422). If there are a plurality of frames with errors, a plurality of frame numbers are transmitted. If the frame number(s) could not be received, then naturally the missing frame number(s) are transmitted.

Upon receiving this signal, the control station 103 searches the content of the memory 106 on the basis of the mobile terminal number, the data number, and the

errors

frame number that have been received, and then retransmits the incorrect frame to the mobile terminal 101 via the base station 102 and the wireless communication line. The mobile terminal 101 sees from the data number that this data is a retransmission of previously received data, and stores the newly received data in a memory area for already-stored data numbers. If there are frames with errors after error correction and detection, the display indicates that there are errors, as during the first reception, and requests retransmission again through the telephone if needed. If it is seen that all the frames were able to be received without errors after error correction, then this is displayed to the display section 304 to notify the mobile terminal owner.

If the telephone 108 is not a PB telephone, the mobile terminal 101 is connected to the mouthpiece of the telephone 108, then no connection can be established with the control station 103 even if the connection key of the keys 307 is pressed and the PB signal is transmitted through the speaker 306. In this case, the mobile terminal owner must manually dial the connection number for the control station 103 from the dial of the telephone 108 and connect to the control station 103 using a DP signal. Next, the mobile terminal owner hears the talkie or the second dial tone from the control station and connects the mobile terminal 101 to the mouthpiece of the telephone 108 and presses a data transmission key of the keys 307, at which the control section 302 the frame number with the error can be extracted from the memory 303 and transmitted together with the data number, the mobile terminal number, and the PB signal through the speaker 306. In this manner, the dialing is done manually at first, but there is no need to input the data number and so on manually, so data entry is extremely simple. FIG. 4 shows a control flow of the mobile terminal.

In the above description, a method was described in which a mobile terminal owner acoustically couples a mobile terminal to a telephone and automatically transmits a data number, frame number, and a mobile terminal number with an error, but it is also possible to provide a special terminal to the telephone and transmit the data electromagnetically, instead of using acoustic coupling. Moreover, it is also naturally possible to display the mobile terminal number, the data number, and the incorrect frame number to the terminal for the mobile terminal owner to enter manually through a PB telephone, instead of automatic transmission.

With this system, if the transmission frame is divided into several pieces, all of the frames included in the mobile terminal number, the data number, and the frame number are transmitted several times, and therefore if any of those are received by the mobile terminal the data is transmitted to the mobile terminal, making it possible to know how many frames were not delivered and making it easy to perform a retransmission request. However, if the transmission data is a single frame or there are only a few frames, the mobile terminal number and so on are transmitted once or only a few times, and if there are errors therein, it would be impossible even to know that data was transmitted to the mobile terminal, making it impossible to request retransmission. To avoid this, a method is conceivable in which only the mobile terminal number, the data number, and all the frames are transmitted multiple times at first, as with existing beepers. Thus if the wireless communication line is good, waste does arise because of the multiple transmissions, but in general these numbers and digits are shorter than the data that is transmitted, and therefore the usage efficiency of the wireless communication line drops almost not at all, even if transmission is repeated several times.

(Effects of the Invention)

As discussed above, with the present invention, in a communication system in which there is a one-way wireless communication line, such as with a beeper provided with a display, ordinarily communication can be performed without multiple data transmissions, which is extremely desirable in terms of efficient usage of wireless communication lines. Incorrect frame numbers are transmitted over a telephone line, but retransmitted data from a control station uses wireless communication lines, meaning no new receiver is needed for the mobile terminal, allowing economical retransmission. Moreover, when a frame number that has an error is transmitted to the control station using a general telephone line, the mobile terminal is coupled with a telephone using acoustic coupling or the like, allowing transmission of incorrect frame numbers and the like using a PB signal

simply by operating keys on the mobile terminal. This provides the effect of making it possible to make a retransmission request using an extremely simple operation. Moreover, by transmitting only the mobile terminal number and all the frames, the reliability of the system can be improved even more.

4. Brief Description of the Drawings

FIG. 1 is one embodiment of the present invention.

FIG. 2 is a frame format of a signal that is transmitted to a mobile terminal 101 from a base station 102 by a control station 103.

FIG. 3 is a block diagram of a mobile terminal.

FIG. 4 is a control flow of the mobile terminal describing operation of the present invention.

101 ... mobile terminal, 102 ... base station,
103 ... control station, 104, 105 ... exchanges in a
general telephone network,
106 ... memory, 107 ... data terminal,
108 ... telephone, 201 ... synchronization signal,
202 ... mobile terminal number, 203 ... data signal,
204 ... frame number, 205 ... data
206 ... error correction detection code, 303 ...
memory,
304 ... display section, 305 ... PB signal generation
section,
306 ... speaker, 307 ... key.

Patent Applicant

NTT Corp.

Patent Application Agent

Keiichi Yamamoto, patent attorney

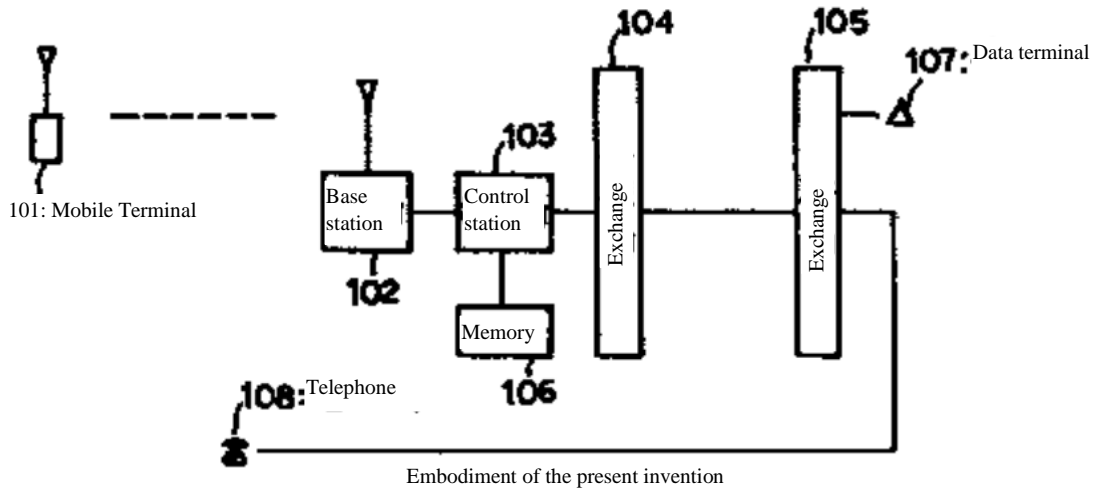

FIG. 1

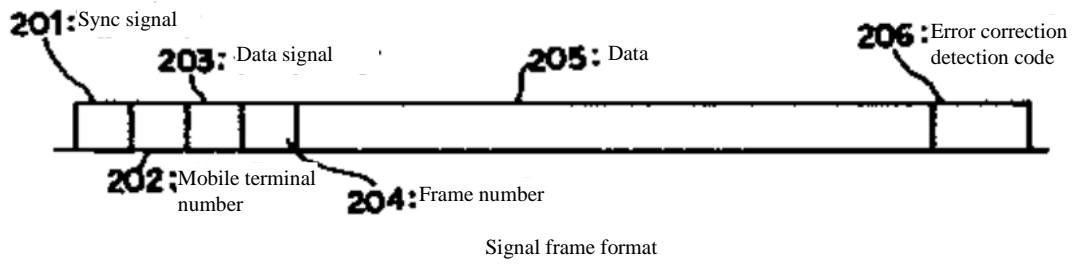

FIG. 2

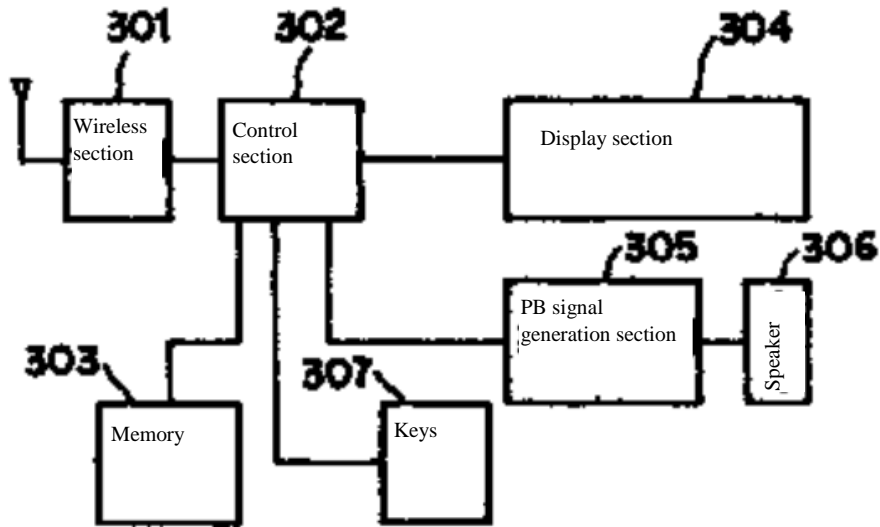

FIG. 3

Explore Litigation Insights

Docket Alarm provides insights to develop a more informed litigation strategy and the peace of mind of knowing you're on top of things.

Real-Time Litigation Alerts



Keep your litigation team up-to-date with **real-time alerts** and advanced team management tools built for the enterprise, all while greatly reducing PACER spend.

Our comprehensive service means we can handle Federal, State, and Administrative courts across the country.

Advanced Docket Research



With over 230 million records, Docket Alarm's cloud-native docket research platform finds what other services can't. Coverage includes Federal, State, plus PTAB, TTAB, ITC and NLRB decisions, all in one place.

Identify arguments that have been successful in the past with full text, pinpoint searching. Link to case law cited within any court document via Fastcase.

Analytics At Your Fingertips



Learn what happened the last time a particular judge, opposing counsel or company faced cases similar to yours.

Advanced out-of-the-box PTAB and TTAB analytics are always at your fingertips.

API

Docket Alarm offers a powerful API (application programming interface) to developers that want to integrate case filings into their apps.

LAW FIRMS

Build custom dashboards for your attorneys and clients with live data direct from the court.

Automate many repetitive legal tasks like conflict checks, document management, and marketing.

FINANCIAL INSTITUTIONS

Litigation and bankruptcy checks for companies and debtors.

E-DISCOVERY AND LEGAL VENDORS

Sync your system to PACER to automate legal marketing.