

Cantilever Beams Part 1 - Beam Stiffness

Stiffness is an Asset – Except in Public Speaking – A discussion of the benefits of using a stiff material in spring design applications.

- **Spring Rate**
- **Stiffness**
- **Stress Distribution**
- **Neutral Axis**
- **Bending Moment**

The cantilever beam is an extremely useful model for electronic spring connectors. The equations that govern the behavior of a straight cantilever beam with rectangular cross section are extremely simple. Given certain assumptions (e.g. small deflections, no yielding), the underlying principles of this type of beam analysis can be extended to electrical spring contacts of most any shape and size.

Electrical contacts are designed to generate a certain amount of contact force (F) for a given amount of deflection (d). The ratio between the force and deflection in either case is referred to as the **spring rate** or **stiffness** of the beam or coil. Occasionally, it is also referred to by the less technically correct term “springiness.” For a coil spring, the force needed to elongate the spring is directly proportional to the distance it elongates. (This assumes that the material does not yield.) The spring rate is then expressed as unit force per unit distance. For example, a coil spring with a spring rate of 2.0 pounds per inch would generate a force of 2.0 pounds for a 1.0 inch deflection, 4.0 pounds for 2 inches, etc.

There is also a linear relationship between the force and deflection of a cantilever beam, as long as the deflection is small and the beam material does not yield. It is also expressed as force per unit distance. For a deflection at the end of the beam perpendicular to the beam axis, the force can be expressed as: $F = \left[\frac{3 \cdot E \cdot I}{L^3} \right] \cdot d$ Here, *E* is the elastic modulus of the spring material, *I* is the area moment of inertia of

the beam cross section, and *L* is the length of the beam. Note that the spring stiffness depends on the geometry of the beam as well as the material stiffness of the beam. For a straight beam with a rectangular cross section, the moment of inertia of the beam, which is a measure of how the cross-sectional area is distributed around its center, is easy to calculate. $I = \frac{1}{12} \cdot w \cdot t^3$ Here, *w* is the strip width and *t* is the strip

thickness. Therefore, the force generated by a given deflection is $F = \left[\frac{E \cdot w \cdot t^3}{4 \cdot L^3} \right] \cdot d$.

The stiffness of the beam is thus given by the bracketed term in the previous equation. Note that the overall stiffness is a function of the elastic modulus (material stiffness) and the dimensions of the beam (geometric stiffness.)

Note that this equation is only valid if the stress in the spring does not exceed the elastic limit of the metal. If the material should start to yield, the elastic modulus is no longer a constant, and the equation will predict a value for force that is much greater than what it is in reality.

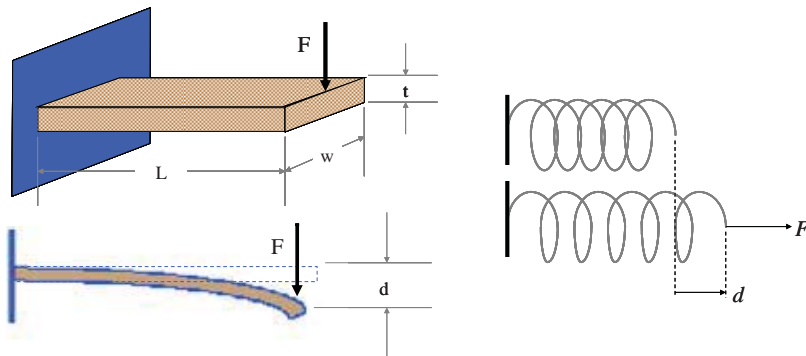

Figure 1. Cantilever Beams vs. Coil Springs

The next issue of Technical will consist of Cantilever Beams Part 2 - Analysis

Cantilever Beams Part 1 – Beam Stiffness (continued)

The next step would be to solve for the **stress distribution** in the beam generated by the given deflection. In a coil spring, the stress is distributed evenly along the length of the coil. However, in a cantilever beam under a bending load, the stress is different at every point in the beam. When a beam is bent downward, the top surface of the beam elongates and is in tension. The bottom surface becomes compressed. Somewhere near the center of the beam, there is a plane that neither elongates nor compresses and thus is under no stress. This is known as the **neutral axis**. The stress will increase from zero at the neutral axis to a maximum value at the upper and lower surfaces, as shown in Figure 2.

The stress will vary along the length of the beam, as well as through the thickness. The stress at any point depends on the bending moment (torque) present at that point. The **bending moment** (M) at any point in the beam is equal to the force applied multiplied by the distance from that point to the point of application. It is therefore zero at the free end of the beam, and maximum at the fixed end. This means that there is no stress at the free end of the beam, and a maximum stress at the fixed end. The equation for the stress at any point in the beam is as follows:

$Stress = \sigma = \frac{M \cdot y}{I} = \frac{F \cdot x}{I} \cdot y$. Here, F is the force

applied, x is the distance from the point of force application, I is the moment of inertia, and y is the distance from the neutral axis. Since the maximum stress will occur at the upper and lower surfaces at

the fixed end, $y_{max} = \frac{t}{2}$ and $x_{Max} = L$. Therefore, the maximum stress can be expressed as

$\sigma_{Max} = \frac{F \cdot L}{I} \cdot \frac{t}{2}$. When the moment of inertia is and the force equation is inserted, the stress equation

reduces to: $\sigma_{Max} = \frac{3 \cdot E \cdot t}{2 \cdot L^2} \cdot d$. Once again, if the material begins to yield, then the above equation is no

longer valid. This is because the metal's stress-strain relationship is no longer linear beyond the elastic limit, and therefore a linear equation is no longer valid.

There are some interesting consequences of these equations. Notice that the width of the beam affects the contact force but has no effect on the stress. The contact force is most influenced by thickness and length, while the stress is most influenced by length. Both the stress and force are linearly proportional to the elastic modulus and the deflection. It becomes much easier to design a contact spring when the relationships among force, stress, geometry, and material are kept in mind. Next month's edition of Technical Tidbits will further explore these relationships.

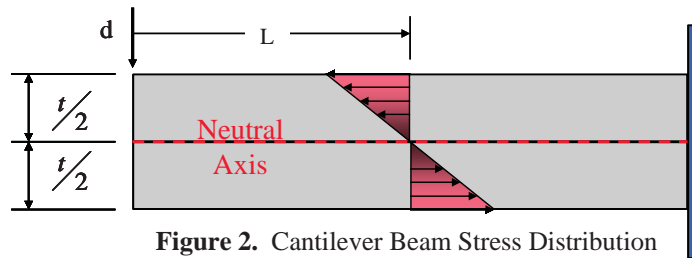

Figure 2. Cantilever Beam Stress Distribution

Written by Mike Gedeon of Brush Wellman's Alloy Customer Technical Service Department. Mr. Gedeon's primary focus is on electronic strip for the telecommunications and computer markets with emphasis on Finite Element Analysis (FEA) and material selection.

TECHNICAL TIDBITS

Brush Wellman Inc.
6070 Parkland Blvd.
Mayfield Heights, OH 44124
(216) 486-4200
(216) 383-4005 Fax
(800) 375-4205 Technical Service



Please contact your local sales representative for further information on spring rate or other questions pertaining to Brush Wellman or our products.

Health and Safety

Handling copper beryllium in solid form poses no special health risk. Like many industrial materials, beryllium-containing materials may pose a health risk if recommended safe handling practices are not followed. Inhalation of airborne beryllium may cause a serious lung disorder in susceptible individuals. The Occupational Safety and Health Administration (OSHA) has set mandatory limits on occupational respiratory exposures. Read and follow the guidance in the Material Safety Data Sheet (MSDS) before working with this material. For additional information on safe handling practices or technical data on copper beryllium, contact Brush Wellman Inc.