

- [54] **APPARATUS AND METHOD FOR PROVIDING DIGITAL AUDIO ON THE SOUND CARRIER OF A STANDARD TELEVISION SIGNAL**
- [75] Inventor: **Clyde Robbins, Maple Glen, Pa.**
- [73] Assignee: **General Instrument Corporation, New York, N.Y.**
- [21] Appl. No.: **22,380**
- [22] Filed: **Mar. 5, 1987**
- [51] Int. Cl.⁴ **H04N 7/04**
- [52] U.S. Cl. **358/143; 380/10; 380/15**
- [58] Field of Search **380/10, 15; 358/143-145, 86**

4,656,629	4/1987	Kondoh et al.	358/143
4,679,085	7/1987	Johnson et al.	358/143
4,682,360	7/1987	Frederiksen	380/10
4,684,981	8/1987	Toyoshima et al.	358/86
4,691,234	4/1987	Albean	358/144
4,710,814	12/1987	Gassmann et al,	358/143
4,745,476	5/1988	Hirashima	358/143

OTHER PUBLICATIONS

Understanding Data Communications, published by Texas Instruments Learning Center, 1984, pp. 4-4 to 4-12.

Primary Examiner—Salvatore Cangialosi
Attorney, Agent, or Firm—Kramer, Brufsky & Cifelli

[57] **ABSTRACT**

A television transmission system replaces the standard FM audio portion of a television signal with digital audio. Three digital audio channels are time division multiplexed on the sound carrier, using combined multi-phase and AM modulation. The audio signals are digitized using adaptive delta modulation techniques. Video vertical and horizontal framing, as well as the audio carrier phase reference, audio data bit time and frame reference, and various control data is carried using AM modulation. The digital audio information is carried using multi-phase modulation. The composite data stream may be serially encrypted to provide security and prevent unauthorized reproduction of the video and/or audio portions of the television signal.

[56] **References Cited**

U.S. PATENT DOCUMENTS

Re. 31,735	11/1984	Davidson	358/124
4,215,366	7/1980	Davidson	358/124
4,266,243	5/1981	Shutterly	380/20
4,295,223	10/1981	Shutterly	358/145
4,353,088	10/1982	van Toonder et al.	380/15
4,402,010	8/1983	Vogelman	358/133
4,405,944	9/1983	Eilers et al.	358/144
4,513,315	4/1985	Dekker et al.	358/86
4,513,327	4/1985	Takahashi et al.	358/310
4,555,730	11/1985	Briggs	358/144
4,605,950	8/1986	Goldberg et al.	358/11
4,608,456	8/1986	Paik et al.	380/28
4,644,580	2/1987	Akagane	358/144

47 Claims, 9 Drawing Sheets

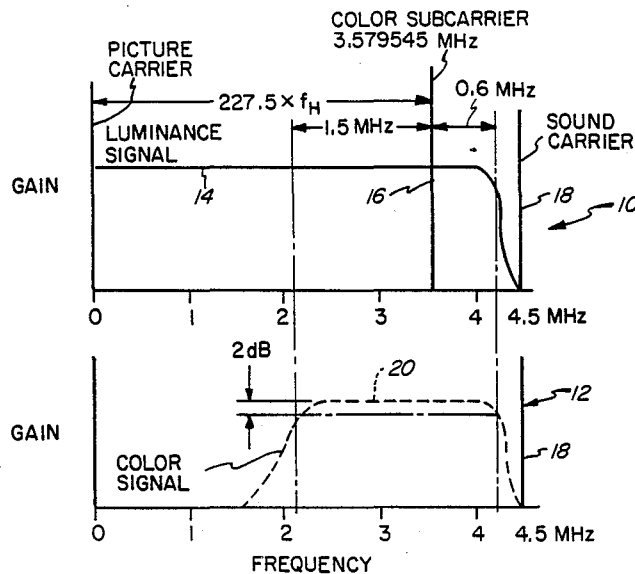

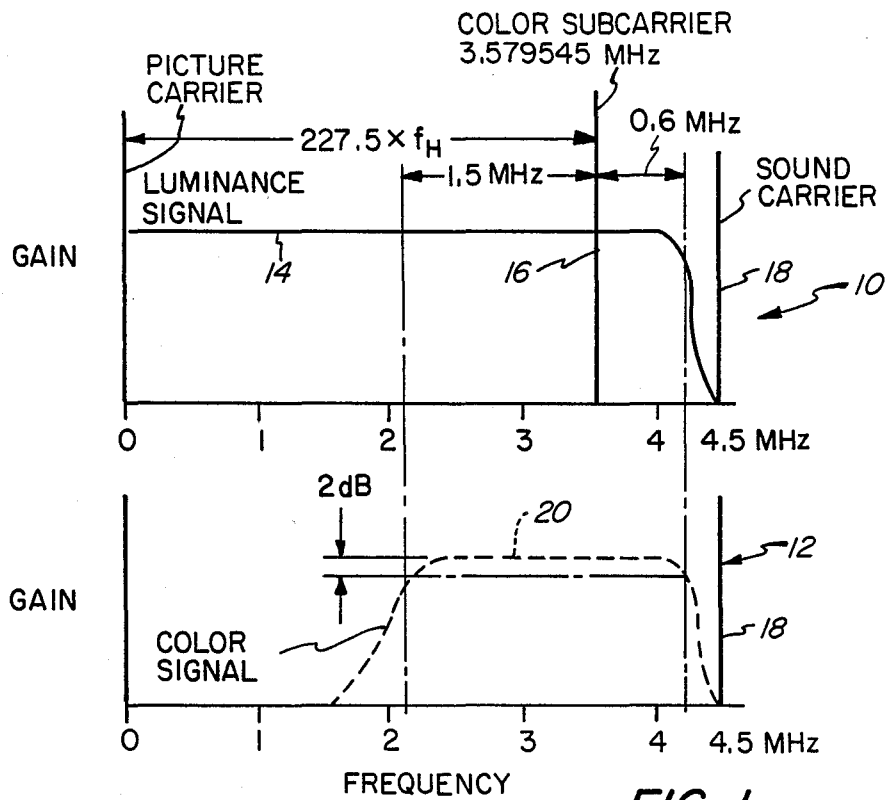

FIG. 1

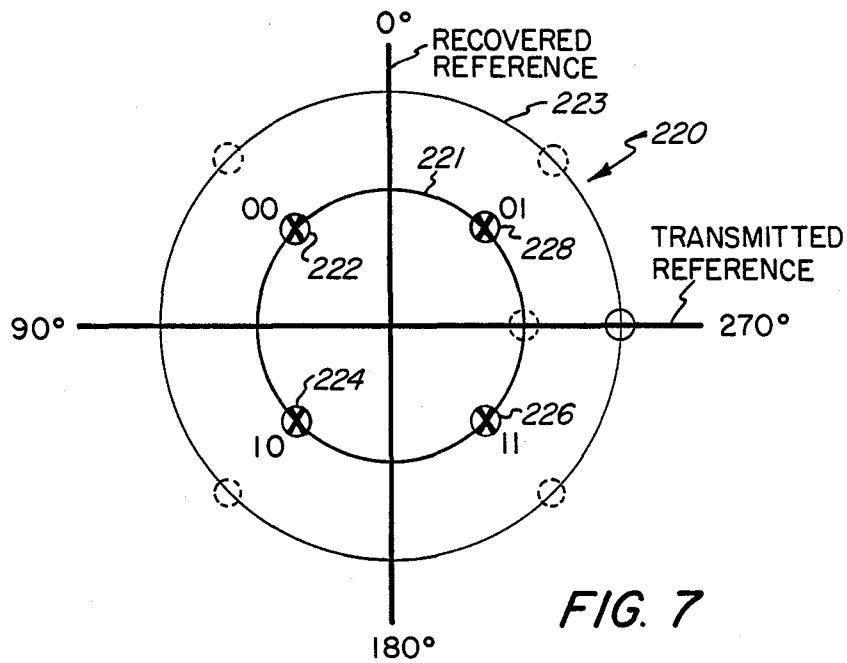

FIG. 7

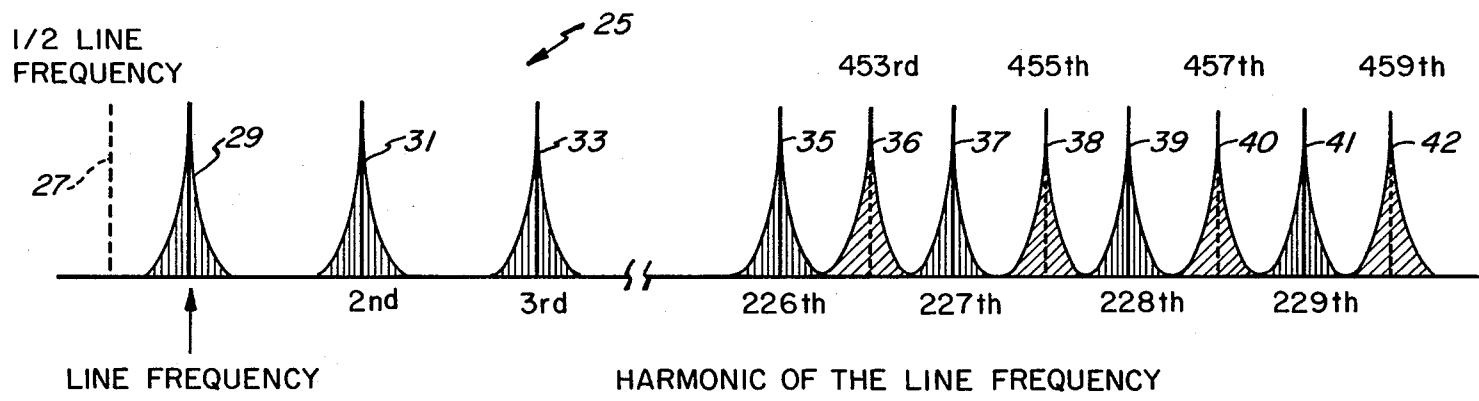
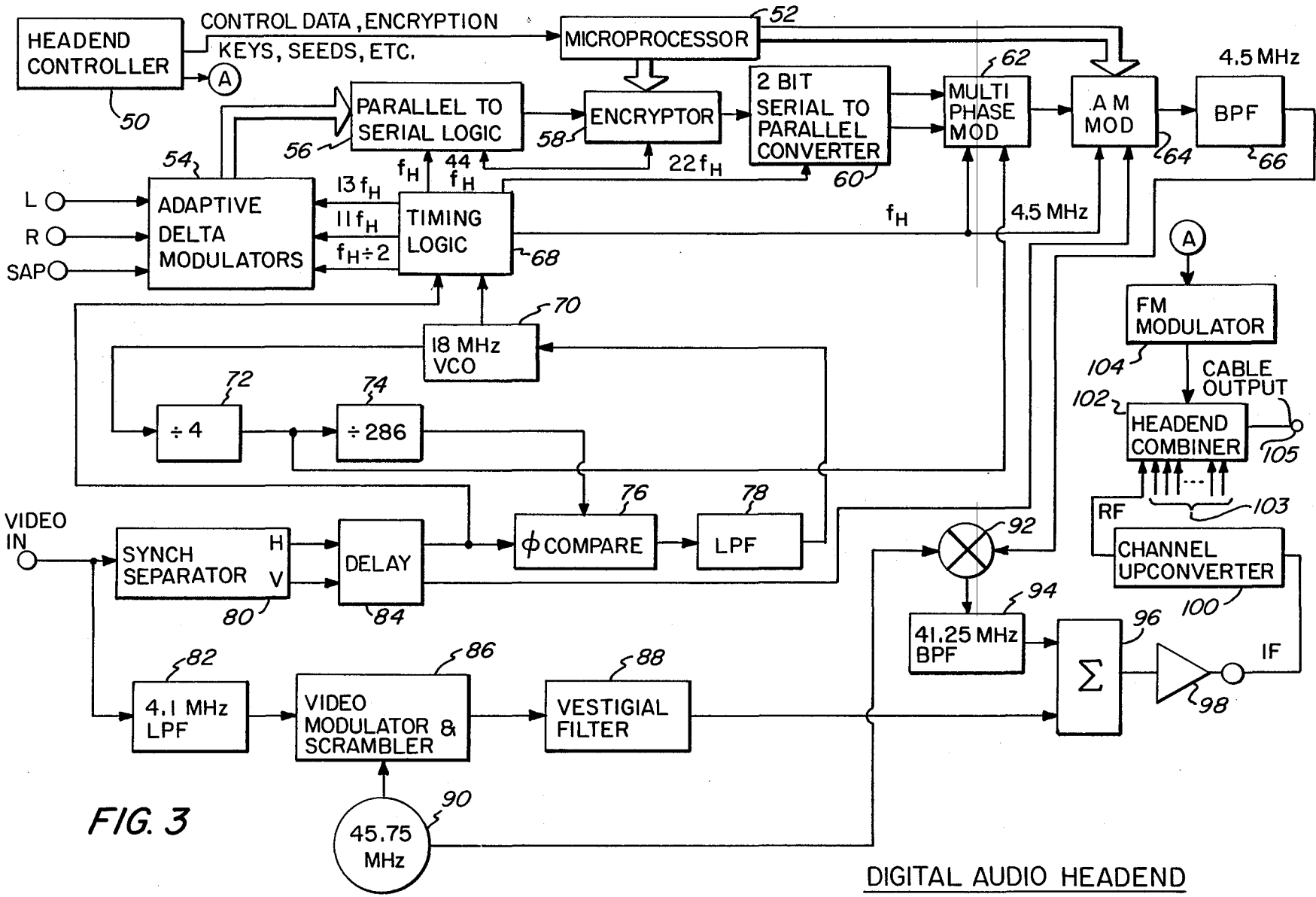

FIG. 2



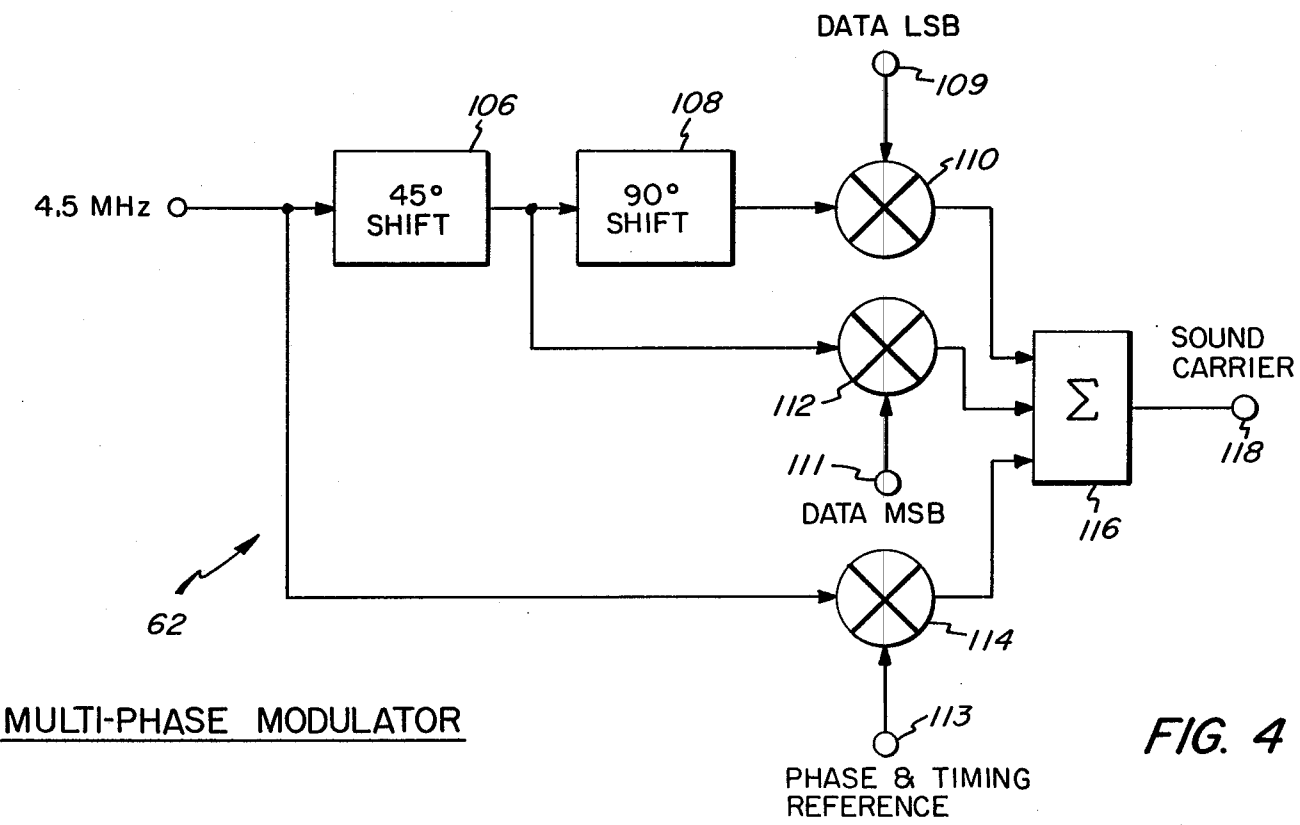

FIG. 4

MULTI-PHASE MODULATOR

Explore Litigation Insights

Docket Alarm provides insights to develop a more informed litigation strategy and the peace of mind of knowing you're on top of things.

Real-Time Litigation Alerts



Keep your litigation team up-to-date with **real-time alerts** and advanced team management tools built for the enterprise, all while greatly reducing PACER spend.

Our comprehensive service means we can handle Federal, State, and Administrative courts across the country.

Advanced Docket Research



With over 230 million records, Docket Alarm's cloud-native docket research platform finds what other services can't. Coverage includes Federal, State, plus PTAB, TTAB, ITC and NLRB decisions, all in one place.

Identify arguments that have been successful in the past with full text, pinpoint searching. Link to case law cited within any court document via Fastcase.

Analytics At Your Fingertips



Learn what happened the last time a particular judge, opposing counsel or company faced cases similar to yours.

Advanced out-of-the-box PTAB and TTAB analytics are always at your fingertips.

API

Docket Alarm offers a powerful API (application programming interface) to developers that want to integrate case filings into their apps.

LAW FIRMS

Build custom dashboards for your attorneys and clients with live data direct from the court.

Automate many repetitive legal tasks like conflict checks, document management, and marketing.

FINANCIAL INSTITUTIONS

Litigation and bankruptcy checks for companies and debtors.

E-DISCOVERY AND LEGAL VENDORS

Sync your system to PACER to automate legal marketing.