

- [54] SYSTEM FOR ELECTRONICALLY CONTROLLABLY VIEWING ON A TELEVISION UPDATEABLE TELEVISION PROGRAMMING INFORMATION
- [75] Inventors: **Eli Reiter**, Dix Hills; **Michael H. Zemerling**, Plainview; **Frank Shannon**, Lindenhurst, all of N.Y.
- [73] Assignee: **David P. Gordon**, Stamford, Conn.
- [21] Appl. No.: **738,283**
- [22] Filed: **May 28, 1985**
- [51] Int. Cl.⁴ **H04N 5/265**
- [52] U.S. Cl. **358/183; 358/22; 358/142; 358/194.1; 358/903**
- [58] Field of Search 358/188, 194.1, 189, 358/190, 85, 191.1, 183, 903, 141, 142, 146, 147, 22; 455/151, 131, 603

4,288,809	9/1981	Yabe	358/12
4,337,480	6/1982	Bourassin et al.	358/183
4,337,483	6/1982	Guillou	358/114
4,344,090	8/1982	Belisomi	358/183
4,390,901	6/1983	Keiser	358/147
4,412,244	10/1983	Shanley	358/22
4,413,281	11/1983	Thonnart	358/147
4,425,581	1/1984	Schwepe	358/148
4,456,925	6/1984	Skerlos et al.	358/85
4,477,830	10/1984	Lindman et al.	358/183
4,495,654	1/1985	Deiss	455/151
4,496,976	1/1985	Swanson et al.	358/183
4,547,804	10/1985	Greenberg	358/142
4,566,034	1/1986	Harger et al.	455/151

Primary Examiner—Tommy P. Chin
 Attorney, Agent, or Firm—David P. Gordon

[56] **References Cited**
U.S. PATENT DOCUMENTS

3,440,427	4/1969	Kammer .	
3,493,674	2/1970	Houghton .	
3,833,757	9/1974	Kirk .	
3,936,868	2/1976	Thorpe	358/22
3,991,792	6/1975	Kimura .	
3,996,583	12/1976	Hutt	340/324 AD
4,026,555	5/1977	Kirschner et al.	358/903
4,052,719	10/1977	Hutt	340/324 AD
4,096,524	6/1978	Scott	358/85
4,134,127	1/1979	Campioni	358/16
4,139,860	2/1979	Micic	358/22
4,161,728	7/1979	Insam	340/750
4,203,130	5/1980	Doumit	358/183
4,205,343	5/1980	Barrett	358/147
4,218,698	8/1980	Bart	358/22
4,231,031	10/1980	Crowther	340/695
4,233,628	11/1980	Ciciora	358/147
4,249,211	2/1981	Baba et al.	358/183
4,261,006	4/1981	Weintraub	358/3
4,264,924	4/1981	Freeman	358/86
4,270,145	5/1981	Farina	358/188

[57] **ABSTRACT**

The electronically controllable system of the invention for viewing on a television, updateable television programming information comprises a microcontroller which is partially controllable by remote control system and is updateable via telephone link, magnetic cards or floppy disks, or television or radio subcarrier, the microcontroller including input/output interfaces, a microprocessor and a RAM; a mixer for mixing a regularly received television signal with the signal generated by the microcontroller; an RF converter for receiving the radio frequency information from the mixer, microcontroller, and television antennae and properly converting the information into information which may be sent to the television; and a remote control system for permitting the viewer to direct the microcontroller to perform searches on information contained in the RAM so as to provide on the television screen in a chosen format, subsets of information desired by the viewer. The system preferably also includes a ROM for directing the microcontroller to access the information link should the RAM lose information due to power failure.

19 Claims, 3 Drawing Sheets

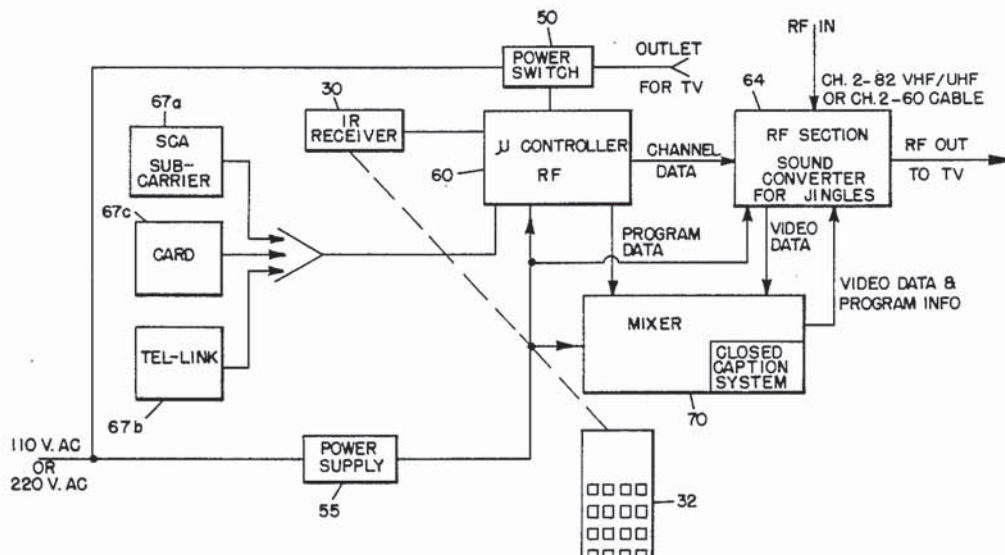

FIG. 1.

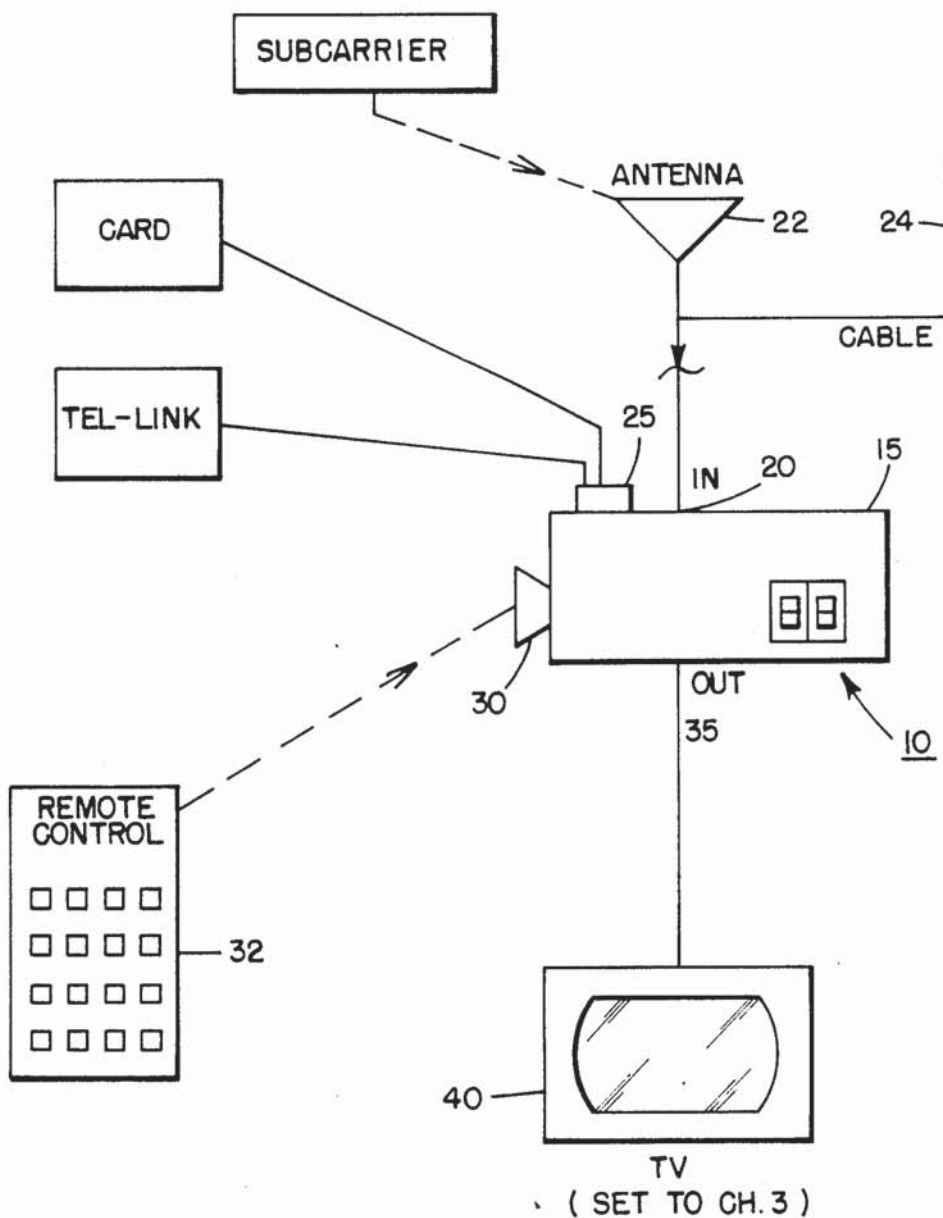

FIG. 2.

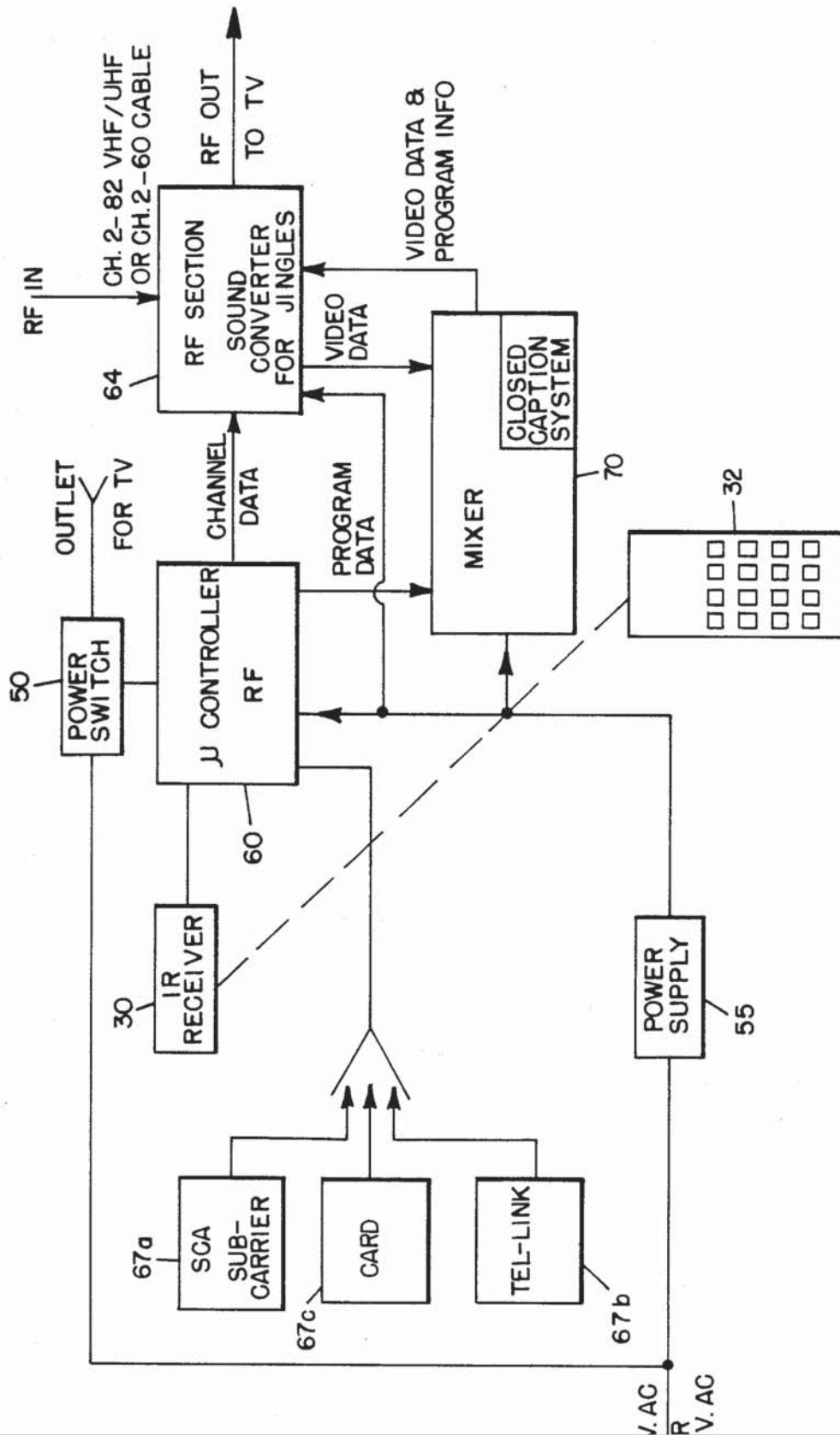
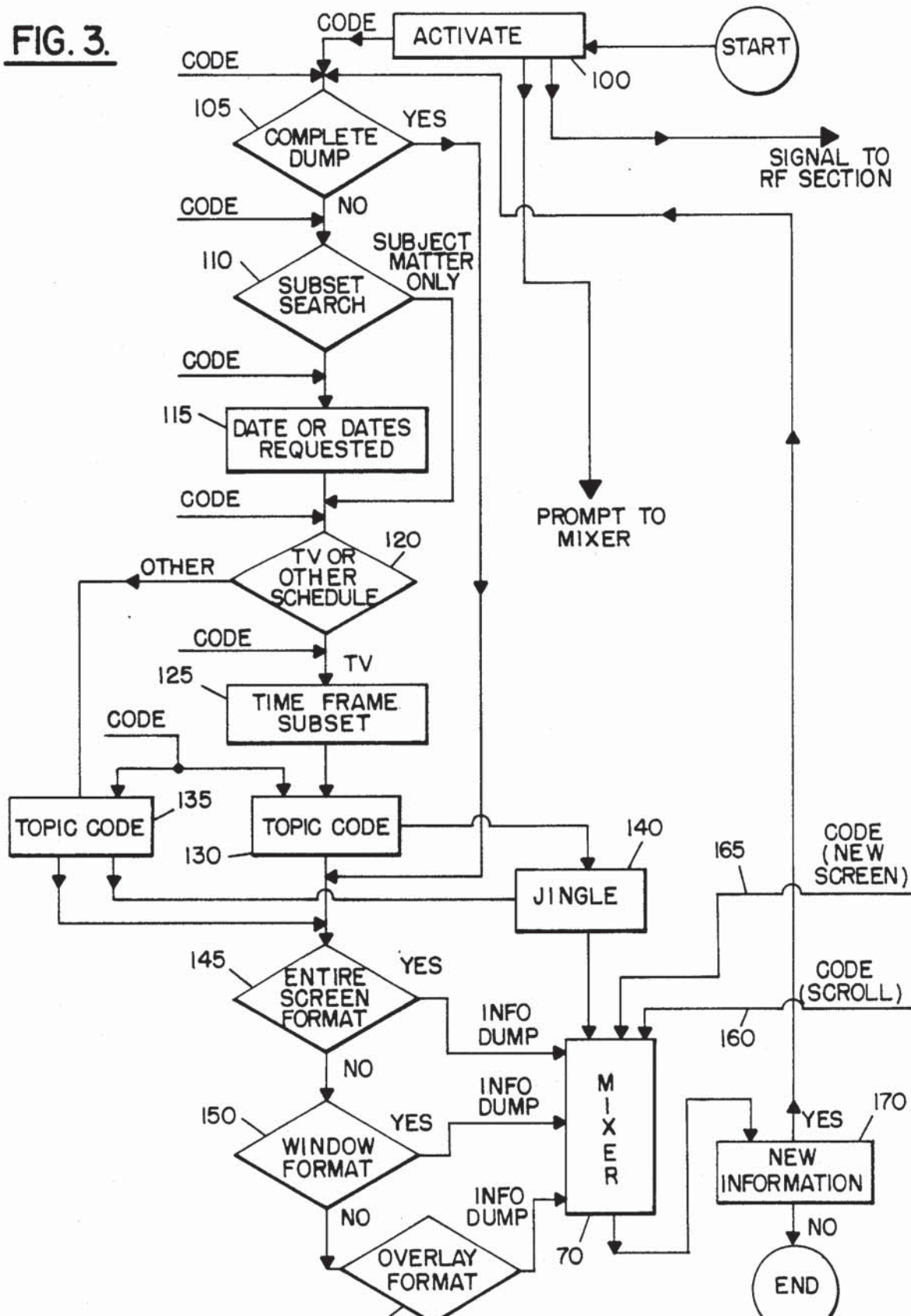

FIG. 3.



**SYSTEM FOR ELECTRONICALLY
CONTROLLABLY VIEWING ON A TELEVISION
UPDATEABLE TELEVISION PROGRAMMING
INFORMATION**

BACKGROUND

The present invention broadly relates to a system which may be attached to, or manufactured within a television set which permits the television owner who subscribes to a particular information service, upon demand, to view on the television screen desired television programming information and subsets thereof. More particularly, the present invention permits the subscriber to controllably view at his leisure the provided updated information such that the information or desired subsets thereof may be viewed on the television either to the exclusion of the received TV signal, or as an overlay to the viewed TV program, or as a window on the screen.

Numerous television accessories, special purpose TV systems, and methods of transmitting auxiliary information to a TV receiver are known in the art. For example, U.S. Pat. No. 4,344,090 to Pietro Belisomi et al., discloses a picture display device which uses a ROM to keep coded data corresponding to a television picture in memory. The coded data is perceived as containing advertising or television operating instructions which may be viewed upon demand and which may be superimposed upon or viewed as an alternative to the received video signal. U.S. Pat. No. 4,288,809 to Yabe describes transmitting alphanumeric information during the blank field intervals of video signals. The added information is identified by an identification code and is stored in temporary memory means for display on the television. The patent further describes an index switch which permits the viewer to determine by an overlay on the screen, which alphanumeric programs are available. The index listing is contained on a RAM which may be updated by the blank field interval transmitted data.

The Insam U.S. Pat. No. 4,161,728 discloses means for displaying "Teletext" and/or "Viewdata" information; the former being information sent during field blanking of video information, and the latter being information sent from telephone. The patent describes means with a memory unit for storing information to be displayed, a display unit for synchronizing and producing addresses to memory containing the information to be displayed, a decoder unit, a control unit which is accessible through remote control, and a microprocessor which is responsive to programmed instruction. The Keiser U.S. Pat. No. 4,390,901 suggests the coding of the type of television programming which is available. The code information would be provided during the vertical blanking gap of the video signal and would be compared to the code contained in the receiver so that a video recorder could be turned on or off depending on how the viewer has programmed the same.

U.S. Pat. No. 4,052,719 to Hutt et al. describes the transmission of auxiliary information during the field blanking intervals of video signal transmission. On the receiving end, a television receiver system has a RAM for collecting and storing information, a selector, and a reading device. The stored information is fed to a character generator repeatedly after the memory is filled. The viewer has the choice of viewing the video signal or the auxiliary information separately or together on the screen. U.S. Pat. No. 4,270,145 to Farina discusses

the use of an alphanumeric character generating circuit with memory and processor for controllably superimposing the time, channel, and other similar information on the video screen. The Doumit et al. U.S. Pat. No. 4,203,130 describes the display of program schedule information and other data to cable subscribers. The information is mixed into the transmission signal on the transmission end and is displayed on the entire television screen.

While all of the above-summarized patents are useful in providing additional information to the viewer, none of the patents permits the viewer to controllably view at his leisure periodically updated information regarding television programming and subsets thereof as either an overlay or window on the display of the received television signals, or as a full screen display.

SUMMARY OF THE INVENTION

It is therefore an object of the invention to provide a system for electronically controllably viewing on a television, updateable television programming information and subsets thereof.

It is a further object of the invention to provide a system which permits a television viewer to obtain, at leisure and upon command, updated television programming information and subsets thereof as an overlay or window on the display of other television signals, or as a full screen display.

It is yet a further object of the invention to provide a system for electronically controllably viewing on a television, updateable television programming information and subsets thereof, the information being provided via telephone link downloading, magnetic cards or floppy disks, or through the use of television or radio subcarriers.

In accord with the objects of the invention, the electronically controllable system of the invention comprises: an eight bit microcontroller which is partially controllable by remote control system and is updateable via telephone link, magnetic cards or floppy disks, or television or radio subcarrier, the microcontroller including input/output interfaces, a microprocessor and an updateable memory; a mixer for mixing a regularly received television signal with the signal generated by the microcontroller; an RF converter for receiving the radio frequency information from the mixer, microcontroller, and television antennae and properly converting the information into information which may be sent to the television; and a remote control system for permitting the viewer to direct the microcontroller to perform searches on information contained in the updateable memory so as to provide on the television screen in a chosen format, subsets of information desired by the viewer. The system preferably also includes a ROM for directing the microcontroller to access the information link should the RAM lose information due to power failure.

In operation, one embodiment of the system of the invention would perform as follows. At a given time on a given date, a subscriber's electronically controllable system of the invention would dial the telephone number of a central computer whose system would be hooked up to the system invention. A week's information, including television listings by code such that subset searches could be accomplished, would be downloaded from the central computer into the updateable

Explore Litigation Insights

Docket Alarm provides insights to develop a more informed litigation strategy and the peace of mind of knowing you're on top of things.

Real-Time Litigation Alerts



Keep your litigation team up-to-date with **real-time alerts** and advanced team management tools built for the enterprise, all while greatly reducing PACER spend.

Our comprehensive service means we can handle Federal, State, and Administrative courts across the country.

Advanced Docket Research



With over 230 million records, Docket Alarm's cloud-native docket research platform finds what other services can't. Coverage includes Federal, State, plus PTAB, TTAB, ITC and NLRB decisions, all in one place.

Identify arguments that have been successful in the past with full text, pinpoint searching. Link to case law cited within any court document via Fastcase.

Analytics At Your Fingertips



Learn what happened the last time a particular judge, opposing counsel or company faced cases similar to yours.

Advanced out-of-the-box PTAB and TTAB analytics are always at your fingertips.

API

Docket Alarm offers a powerful API (application programming interface) to developers that want to integrate case filings into their apps.

LAW FIRMS

Build custom dashboards for your attorneys and clients with live data direct from the court.

Automate many repetitive legal tasks like conflict checks, document management, and marketing.

FINANCIAL INSTITUTIONS

Litigation and bankruptcy checks for companies and debtors.

E-DISCOVERY AND LEGAL VENDORS

Sync your system to PACER to automate legal marketing.