



United States Patent [19]

[11] **Patent Number:** **6,006,838**

Whiteley et al.

[45] **Date of Patent:** **Dec. 28, 1999**

[54] **APPARATUS AND METHOD FOR STIMULATING MULTIPLE PRODUCTION ZONES IN A WELLBORE**

4,043,392	8/1977	Gazda	166/217
5,135,051	8/1992	Facteau et al.	166/104
5,165,438	11/1992	Facteau et al.	137/1
5,181,569	1/1993	McCoy et al.	166/317
5,228,508	7/1993	Facteau et al.	166/177
5,462,129	10/1995	Best et al.	175/67
5,533,571	7/1996	Surjaatmadja et al.	166/222

[75] Inventors: **T. G. Whiteley**, Houston; **Douglas J. Lehr**, Woodlands; **Michael A. Martin**; **Dennis Atchley**, both of Midland, all of Tex.

Primary Examiner—William Neuder
Assistant Examiner—John Kreck
Attorney, Agent, or Firm—Arnold White & Durkee

[73] Assignee: **BJ Services Company**, Houston, Tex.

[21] Appl. No.: **09/169,910**

[57] **ABSTRACT**

[22] Filed: **Oct. 12, 1998**

An apparatus and method for selectively stimulating a plurality of producing zones of an openhole wellbore in oil and gas wells in one trip. The assembly includes a plurality of modules connected in a tailpipe wherein the modules can be selectively actuated to conduct a matrix acidizing job and near wellbore erosion job on producing zones of interest in the wellbore. Each module includes a sleeve shiftable between a closed position and a treating position where a plurality of jet passageways are exposed to the central passageway of the assembly.

[51] **Int. Cl.⁶** **E21B 43/25**

[52] **U.S. Cl.** **166/306; 166/318**

[58] **Field of Search** 166/306, 307, 166/318, 319, 222, 177.5

[56] **References Cited**

U.S. PATENT DOCUMENTS

2,327,051	7/1943	Lyons et al.	166/222
2,997,108	5/1961	Sievers	166/222
3,912,173	10/1975	Robichaux	239/443

29 Claims, 3 Drawing Sheets

**WEATHERFORD
INTERNATIONAL, LLC, et al.**

EXHIBIT 1019

**WEATHERFORD
INTERNATIONAL, LLC, et al.**

v.

**PACKERS PLUS ENERGY
SERVICES, INC.**

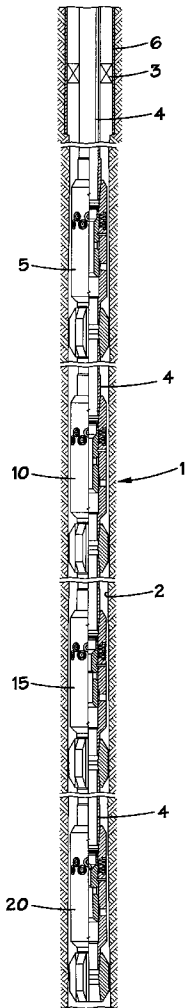

FIG. 1

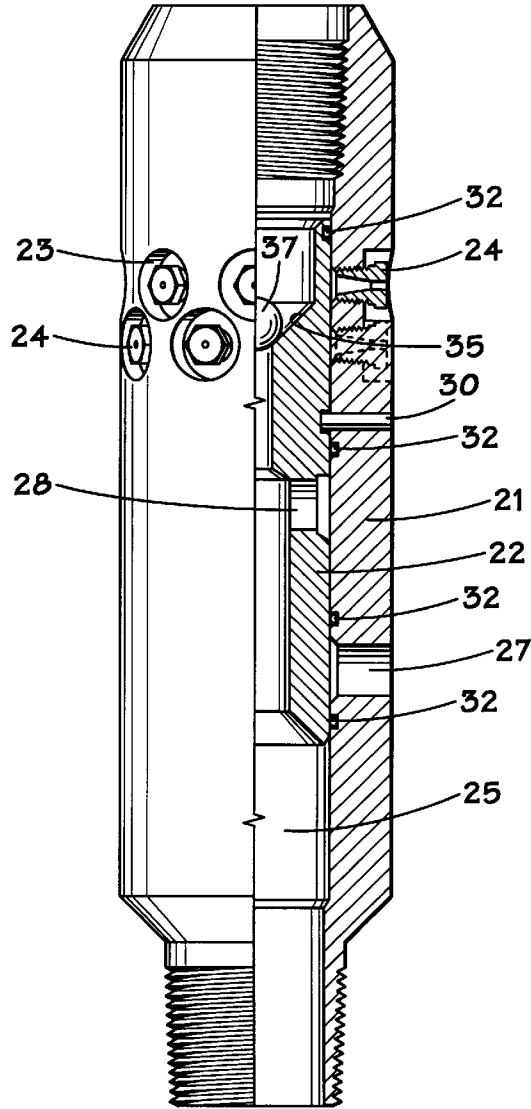
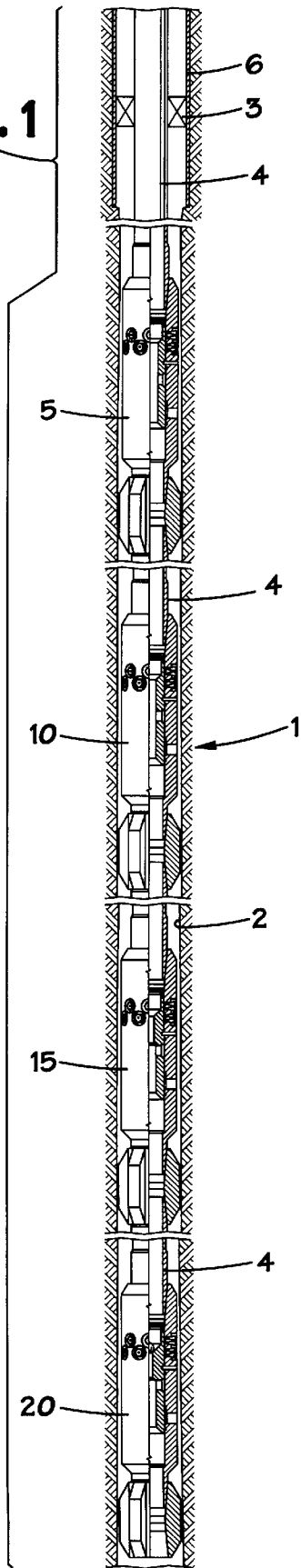

FIG. 2

FIG. 3

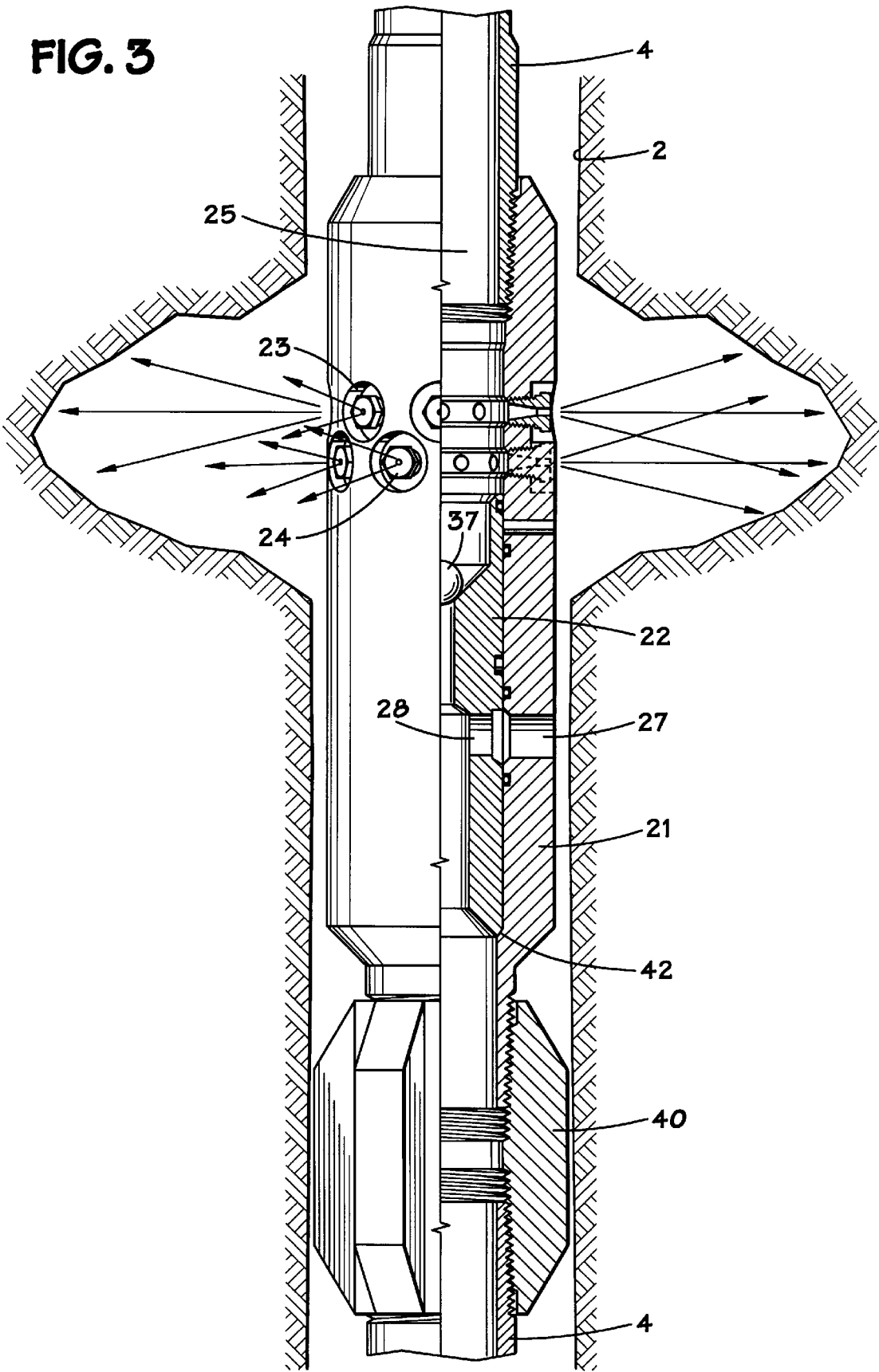
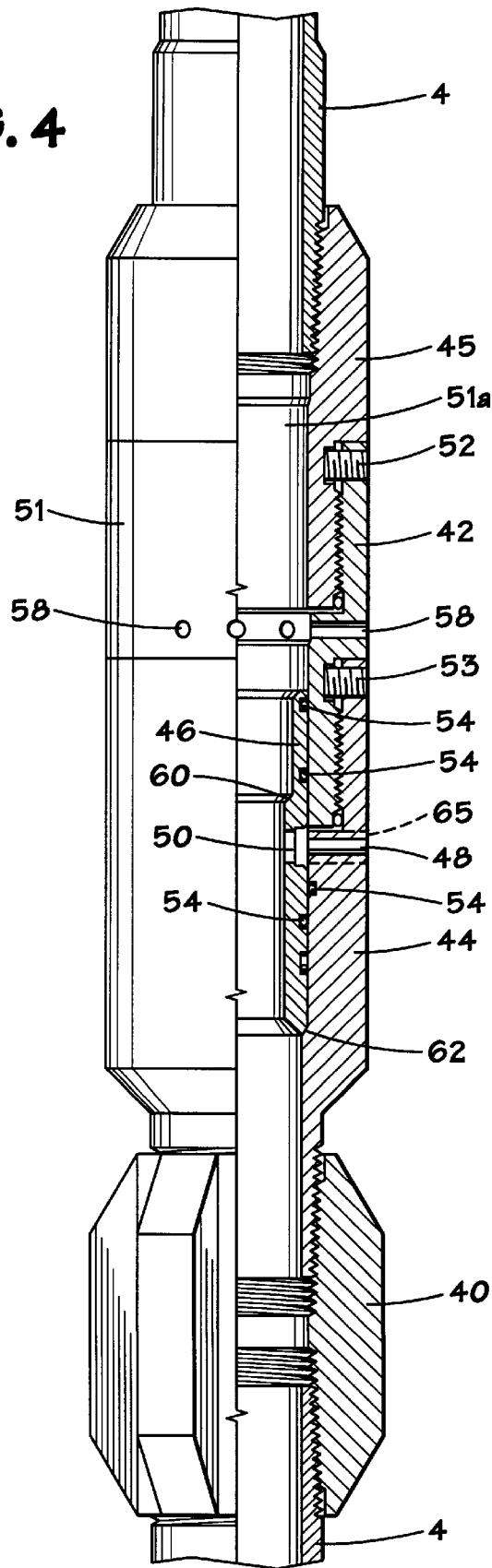

FIG. 4



APPARATUS AND METHOD FOR STIMULATING MULTIPLE PRODUCTION ZONES IN A WELLBORE

BACKGROUND OF THE INVENTION

This invention relates to an apparatus and method for stimulating producing zones of an openhole wellbore in oil and gas wells. More particularly, the invention relates to an assembly for selectively stimulating a wellbore without the use of openhole inflatable packers. The assembly is especially suited to perform a combination of matrix acidizing jobs and near wellbore erosion jobs at a number of producing zones in the wellbore in a single trip.

Previously, operators who were interested in stimulating multiple producing zones in an openhole wellbore could stimulate the zones one zone at a time by using a workstring and an openhole inflatable packer. Such a method and assembly required the operator to set an inflatable packer (or other similar apparatus) above each zone of interest to be stimulated and then, following the stimulation job, to release the packer (or packers) and trip the packer assembly to a new location where it would be reset for the next stimulation job. This procedure would be repeated for each desired zone of interest. However, because of the tripping time and the difficulty in setting and maintaining the seal in inflatable packers in openhole wellbores, such a method was both time consuming and relatively unreliable. Furthermore, openhole inflatable packers (or other similar devices) are expensive to rent or to purchase. As a result of the relative unreliability and cost of using openhole inflatable packers, such assemblies prove to be uneconomical in marginal fields such as fields in the Permian Basin region of West Texas and Eastern New Mexico.

The assembly of the present invention does not require an inflatable packer and is very economical to build and maintain. Thus, an operator can use the present invention for a small incremental cost over what it costs to perform an acid job and receives the benefits of not only a matrix acidizing treatment, but can also enhance the flow in the near wellbore region by eroding away near wellbore skin damage. In addition, the present invention allows an operator to accurately position an assembly in a wellbore to ensure that the producing zones of interest are stimulated.

SUMMARY OF THE INVENTION

One embodiment of the present invention is directed to an assembly for selectively stimulating a plurality of producing zones in an oil and gas well comprising a tailpipe string, a plurality of modules spaced in the tailpipe string at predetermined locations, wherein each module comprises a housing having a central passageway therethrough, a plurality of jetting passageways extending radially through the housing, and a shifting sleeve slidably mounted within the housing wherein the shifting sleeve is moveable from a closed position over the jet passageways to an open position whereby the jet passageways are in communication with the central passageway of the housing and wherein the shifting sleeve includes a ball seat for receiving an actuating ball for shifting the shifting sleeve from the closed position to the open position. The lowermost module in the assembly is adapted to receive an actuating ball and each successive module in the assembly is adapted to receive a larger actuating ball than the module immediately below it. The size of the ball seat will differ from module to module with the lowermost module having the smallest ball seat and each successive module in the assembly will have a larger ball

seat than the module immediately below it. Each of the jet passageways may include a jet nozzle.

In another embodiment, the housing may include an interchangeable nozzle body wherein the jet passageways extend radially through the nozzle body. The housing may further comprise a top sub connected to the upper end of the nozzle body and a bottom sub connected to the lower end of the nozzle body.

Each module may further comprise one or more radially extending flow ports in the shifting sleeve beneath the ball seat which communicates with one or more flow ports in the housing when the shifting sleeve is in the open position.

Another embodiment of the present invention is directed to an assembly for selectively stimulating a plurality of producing zones in an oil and gas well comprising a plurality of modules connected in a tailpipe string wherein each module comprises a housing having a central passageway therethrough, one or more jetting passageways extending radially through the housing, and a shiftable sleeve mounted in the central passageway of the module, wherein the shiftable sleeve is moveable from a closed position over the jet passageways to an open position whereby the jet passageways are in communication with the central passageway of the housing, and wherein the shiftable sleeve is adapted to receive an actuating means for shifting the shiftable sleeve from the closed position to the open position. The actuating means may include balls, darts, bars, plugs or similar devices.

BRIEF DESCRIPTION OF THE DRAWINGS

1.) FIG. 1 illustrates a partial cutaway of an assembly for selectively stimulating a plurality of producing zones in an openhole wellbore.

2.) FIG. 2 shows a partial cutaway of one embodiment of a module used in the assembly shown in FIG. 1.

3.) FIG. 3 illustrates the module of FIG. 2 with the shifting sleeve in the open position.

4.) FIG. 4 shows a partial cutaway of an alternative embodiment of a module for use in an assembly for selectively stimulating a plurality of producing zones in a wellbore.

DESCRIPTION OF ILLUSTRATIVE EMBODIMENTS

The illustrative embodiments described herein provide an apparatus and method for selectively stimulating multiple production zones or intervals within a subterranean oil or gas well in a single trip. Persons of ordinary skill in the art, having the benefit of the present disclosure, will recognize that the teachings of the present disclosure will find application in any number of alternative embodiments employing the general teachings of the illustrative embodiments. Therefore, the described directstem assembly and method of using the same to selectively stimulate producing zones in a wellbore are meant to be illustrative and not limiting. Accordingly, while the present invention is well-suited for use in horizontal wellbores, the invention is only illustrated in the accompanying drawings in a substantially vertical wellbore. Persons of ordinary skill in the art will understand that terms such as "lowermost" and "uppermost" in terms of horizontal wellbores are relative indications of the distance or depth from the surface location of the wellbore.

Referring to FIGS. 1-3, a preferred embodiment of an assembly for selectively stimulating producing zones in a subterranean wellbore will now be described. The direct-

Explore Litigation Insights

Docket Alarm provides insights to develop a more informed litigation strategy and the peace of mind of knowing you're on top of things.

Real-Time Litigation Alerts



Keep your litigation team up-to-date with **real-time alerts** and advanced team management tools built for the enterprise, all while greatly reducing PACER spend.

Our comprehensive service means we can handle Federal, State, and Administrative courts across the country.

Advanced Docket Research



With over 230 million records, Docket Alarm's cloud-native docket research platform finds what other services can't. Coverage includes Federal, State, plus PTAB, TTAB, ITC and NLRB decisions, all in one place.

Identify arguments that have been successful in the past with full text, pinpoint searching. Link to case law cited within any court document via Fastcase.

Analytics At Your Fingertips



Learn what happened the last time a particular judge, opposing counsel or company faced cases similar to yours.

Advanced out-of-the-box PTAB and TTAB analytics are always at your fingertips.

API

Docket Alarm offers a powerful API (application programming interface) to developers that want to integrate case filings into their apps.

LAW FIRMS

Build custom dashboards for your attorneys and clients with live data direct from the court.

Automate many repetitive legal tasks like conflict checks, document management, and marketing.

FINANCIAL INSTITUTIONS

Litigation and bankruptcy checks for companies and debtors.

E-DISCOVERY AND LEGAL VENDORS

Sync your system to PACER to automate legal marketing.