

FUNDAMENTALS OF
HEAT AND MASS
TRANSFER



Third Edition



FRANK P. INCROPERA
DAVID P. DE WITT





THIRD EDITION

FUNDAMENTALS OF HEAT AND MASS TRANSFER

FRANK P. INCROPERA

DAVID P. DEWITT

School of Mechanical Engineering
Purdue University



JOHN WILEY & SONS

New York • Chichester • Brisbane • Toronto • Singapore

QC 320
.I45
1990
copy 2

Dedicated to those wonderful women in our lives,

*Amy, Andrea, Debbie, Donna, Jody,
Karen, Shaunna, and Terri*

who, through the years, have blessed us with
their love, patience, and understanding.

Copyright © 1981, 1985, 1990, by John Wiley & Sons, Inc.

All rights reserved. Published simultaneously in Canada.

Reproduction or translation of any part of
this work beyond that permitted by Sections
107 and 108 of the 1976 United States Copyright
Act without the permission of the copyright
owner is unlawful. Requests for permission
or further information should be addressed to
the Permissions Department, John Wiley & Sons.



Library of Congress Cataloging in Publication Data:

Incropera, Frank P.
Fundamentals of heat and mass transfer/Frank P. Incropera, David
P. DeWitt.—3rd ed.

p. cm.

Includes bibliographical references.

ISBN 0-471-61246-4

1. Heat—Transmission. 2. Mass transfer. I. DeWitt, David P.,
1934—. II. Title.

QC320.I45 1990
621.402'2—dc20

89-38319
CIP

Printed in the United States of America

10 9 8 7 6 5 4 3 2 1

CHAPTER 5

K) and contains is passed. Under 1 a uniform heat r flow provides a : $5000 \text{ W/m}^2 \cdot \text{K}$ state temperature erations, we may preceding page. , use a finite-dif-

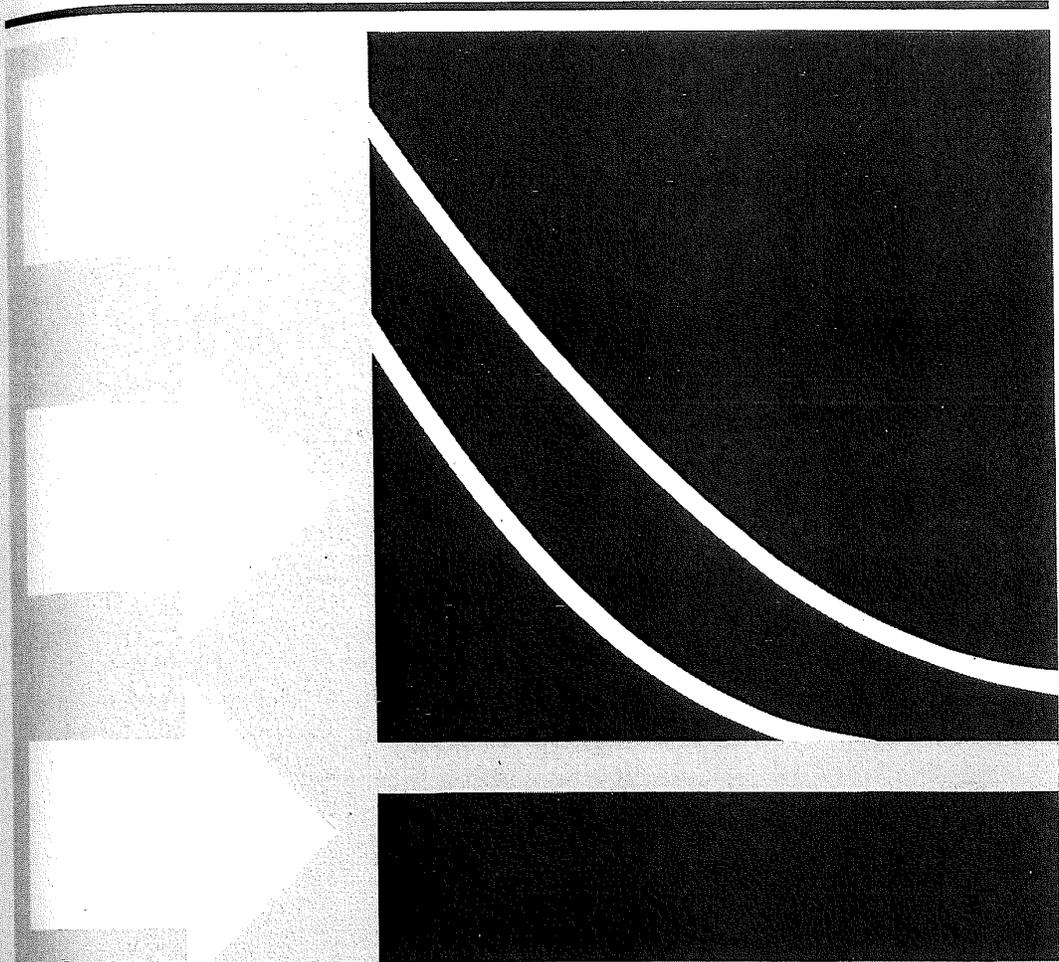

TRANSIENT CONDUCTION

In our treatment of conduction we have gradually considered more complicated conditions. We began with the simple case of one-dimensional, steady-state conduction with no internal generation, and we subsequently considered complications due to multidimensional and generation effects. However, we have not yet considered situations for which conditions change with time.

We now recognize that many heat transfer problems are time dependent. Such *unsteady*, or *transient*, problems typically arise when the boundary conditions of a system are changed. For example, if the surface temperature of a system is altered, the temperature at each point in the system will also begin to change. The changes will continue to occur until a *steady-state* temperature distribution is reached. Consider a hot metal billet that is removed from a furnace and exposed to a cool airstream. Energy is transferred by convection and radiation from its surface to the surroundings. Energy transfer by conduction also occurs from the interior of the metal to the surface, and the temperature at each point in the billet decreases until a steady-state condition is reached. Such time-dependent effects occur in many industrial heating and cooling processes.

To determine the time dependence of the temperature distribution within a solid during a transient process, we could begin by solving the appropriate form of the heat equation, for example, Equation 2.13. Some cases for which solutions have been obtained are discussed in Sections 5.4 to 5.8. However, such solutions are often difficult to obtain, and where possible a simpler approach is preferred. One such approach may be used under conditions for which temperature gradients within the solid are small. It is termed the *lumped capacitance method*.

5.1 THE LUMPED CAPACITANCE METHOD

A simple, yet common, transient conduction problem is one in which a solid experiences a sudden change in its thermal environment. Consider a hot metal forging that is initially at a uniform temperature T_i and is quenched by immersing it in a liquid of lower temperature $T_\infty < T_i$ (Figure 5.1). If the quenching is said to begin at time $t = 0$, the temperature of the solid will

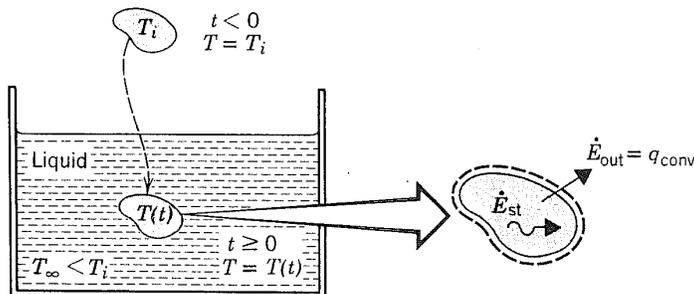

Figure 5.1 Cooling of a hot metal forging.

decrease
convective
lumped
solid is
assumpt

From
gradient
tion is c
exactly,
solid is
and its

In
conside
the tran
energy
the sur.
1.11a to

or

Introdu

θ

and re

$\frac{\rho}{h}$

Separat
and T

$\frac{f}{l}$

where

θ

Evalu

more compli-
onal, steady-
ly considered
However, we
with time.

ie dependent.
he boundary
emperature of
will also begin
emperature
oved from a
y convection
er by conduc-
ace, and the
ate condition
al heating and

tribution within
e appropriate
uses for which
5.8. However,
ble a simpler
conditions for
ed the *lumped*

which a solid
er a hot metal
quenched by
re 5.1). If the
the solid will

decrease for time $t > 0$, until it eventually reaches T_∞ . This reduction is due to convection heat transfer at the solid-liquid interface. The essence of the lumped capacitance method is the assumption that the temperature of the solid is *spatially uniform* at any instant during the transient process. This assumption implies that temperature gradients within the solid are negligible.

From Fourier's law, heat conduction in the absence of a temperature gradient implies the existence of infinite thermal conductivity. Such a condition is clearly impossible. However, although the condition is never satisfied exactly, it is closely approximated if the resistance to conduction within the solid is small compared with the resistance to heat transfer between the solid and its surroundings. For now we assume that this is, in fact, the case.

In neglecting temperature gradients within the solid, we can no longer consider the problem from within the framework of the heat equation. Instead, the transient temperature response is determined by formulating an overall energy balance on the solid. This balance must relate the rate of heat loss at the surface to the rate of change of the internal energy. Applying Equation 1.11a to the control volume of Figure 5.1, this requirement takes the form

$$-\dot{E}_{\text{out}} = \dot{E}_{\text{st}} \quad (5.1)$$

or

$$-hA_s(T - T_\infty) = \rho Vc \frac{dT}{dt} \quad (5.2)$$

Introducing the temperature difference

$$\theta \equiv T - T_\infty \quad (5.3)$$

and recognizing that $(d\theta/dt) = (dT/dt)$, it follows that

$$\frac{\rho Vc}{hA_s} \frac{d\theta}{dt} = -\theta$$

Separating variables and integrating from the initial condition, for which $t = 0$ and $T(0) = T_i$, we then obtain

$$\frac{\rho Vc}{hA_s} \int_{\theta_i}^{\theta} \frac{d\theta}{\theta} = - \int_0^t dt$$

where

$$\theta_i \equiv T_i - T_\infty \quad (5.4)$$

Evaluating the integrals it follows that

$$\frac{\rho Vc}{hA_s} \ln \frac{\theta}{\theta_i} = -t \quad (5.5)$$

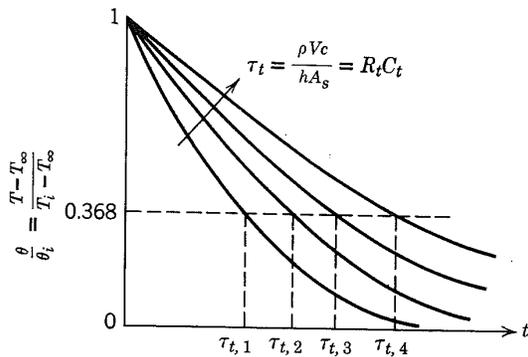

Figure 5.2 Transient temperature response of lumped capacitance solids corresponding to different thermal time constants τ_t .

or

$$\frac{\theta}{\theta_i} = \frac{T - T_\infty}{T_i - T_\infty} = \exp \left[- \left(\frac{hA_s}{\rho Vc} \right) t \right] \quad (5.6)$$

Equation 5.5 may be used to determine the time required for the solid to reach some temperature T , or, conversely, Equation 5.6 may be used to compute the temperature reached by the solid at some time t .

The foregoing results indicate that the difference between the solid and fluid temperatures must decay exponentially to zero as t approaches infinity. This behavior is shown in Figure 5.2. From Equation 5.6 it is also evident that the quantity $(\rho Vc/hA_s)$ may be interpreted as a *thermal time constant*. This time constant may be expressed as

$$\tau_t = \left(\frac{1}{hA_s} \right) (\rho Vc) = R_t C_t \quad (5.7)$$

where R_t is the resistance to convection heat transfer and C_t is the *lumped thermal capacitance* of the solid. Any increase in R_t or C_t will cause a solid to respond more slowly to changes in its thermal environment and will increase the time required to reach thermal equilibrium ($\theta = 0$).

It is useful to note that the foregoing behavior is analogous to the voltage decay that occurs when a capacitor is discharged through a resistor in an electrical RC circuit. Accordingly, the process may be represented by an *equivalent thermal circuit*, which is shown in Figure 5.3. With the switch closed the solid is charged to the temperature θ_i . When the switch is opened, the energy that is stored in the solid is discharged through the thermal resistance and the temperature of the solid decays with time. This analogy suggests that RC electrical circuits may be used to determine the transient behavior of thermal systems. In fact, before the advent of digital computers, RC circuits were widely used to simulate transient thermal behavior.

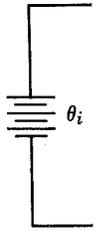

Figure 5.3 Equivalent thermal circuit for a lumped capacitance solid.

To simply

Q

Substit

Q

The q solid,

For q Equat ($\theta < 0$) increa

5.2. VAL

From using conve Hence reason

the p. condi surfac a fluid

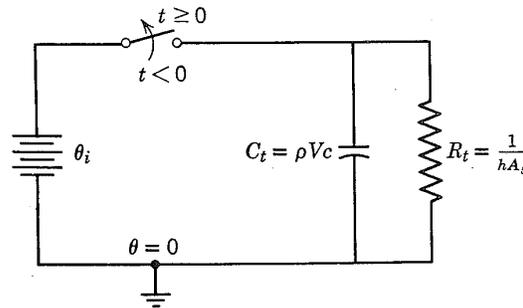

Figure 5.3 Equivalent thermal circuit for a lumped capacitance solid.

To determine the total energy transfer Q occurring up to some time t , we simply write

$$Q = \int_0^t q dt = hA_s \int_0^t \theta dt \tag{5.6}$$

Substituting for θ from Equation 5.6 and integrating, we obtain

$$Q = (\rho V c) \theta_i \left[1 - \exp\left(-\frac{t}{\tau_t}\right) \right] \tag{5.8a}$$

The quantity Q is, of course, related to the change in the internal energy of the solid, and from Equation 1.11b

$$-Q = \Delta E_{st} \tag{5.8b}$$

For quenching Q is positive and the solid experiences a decrease in energy. Equations 5.5, 5.6, and 5.8a also apply to situations where the solid is heated ($\theta < 0$), in which case Q is negative and the internal energy of the solid increases.

5.2 VALIDITY OF THE LUMPED CAPACITANCE METHOD

From the foregoing results it is easy to see why there is a strong preference for using the lumped capacitance method. It is certainly the simplest and most convenient method that can be used to solve transient conduction problems. Hence it is important to determine under what conditions it may be used with reasonable accuracy.

To develop a suitable criterion consider steady-state conduction through the plane wall of area A (Figure 5.4). Although we are assuming steady-state conditions, this criterion is readily extended to transient processes. One surface is maintained at a temperature $T_{s,1}$ and the other surface is exposed to a fluid of temperature $T_\infty < T_{s,1}$. The temperature of this surface will be some

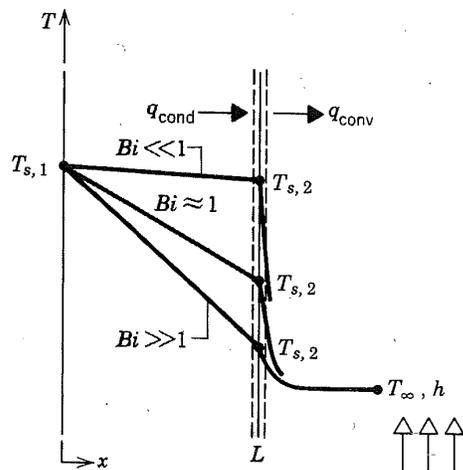

Figure 5.4 Effect of Biot number on steady-state temperature distribution in a plane wall with surface convection.

intermediate value, $T_{s,2}$, for which $T_{\infty} < T_{s,2} < T_{s,1}$. Hence under steady-state conditions the surface energy balance, Equation 1.12, reduces to

$$\frac{kA}{L}(T_{s,1} - T_{s,2}) = hA(T_{s,2} - T_{\infty})$$

where k is the thermal conductivity of the solid. Rearranging, we then obtain

$$\frac{T_{s,1} - T_{s,2}}{T_{s,2} - T_{\infty}} = \frac{(L/kA)}{(1/hA)} = \frac{R_{\text{cond}}}{R_{\text{conv}}} = \frac{hL}{k} \equiv Bi \quad (5.9)$$

The quantity (hL/k) appearing in Equation 5.9 is a *dimensionless parameter*. It is termed the *Biot number*, and it plays a fundamental role in conduction problems that involve surface convection effects. According to Equation 5.9 and as illustrated in Figure 5.4, the Biot number provides a measure of the temperature drop in the solid relative to the temperature difference between the surface and the fluid. Note especially the conditions corresponding to $Bi \ll 1$. The results suggest that, for these conditions, it is reasonable to *assume* a uniform temperature distribution across a solid at any time during a transient process. This result may also be associated with interpretation of the Biot number as a ratio of thermal resistances, Equation 5.9. *If $Bi \ll 1$, the resistance to conduction within the solid is much less than the resistance to convection across the fluid boundary layer.* Hence the assumption of a uniform temperature distribution is reasonable.

We have introduced the Biot number because of its significance to transient conduction problems. Consider the plane wall of Figure 5.5, which is initially at a uniform temperature T_i and experiences convection cooling when it is immersed in a fluid of $T_{\infty} < T_i$. The problem may be treated as one dimensional in x , and we are interested in the temperature variation with position and time, $T(x, t)$. This variation is a strong function of the Biot

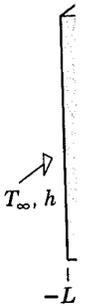

Figure wall sy

numb
tempo
the t
temp
large
solid
ture
surfa

capac
solvin
probl
the f

the e
conv
as th
facili
half-
long
the c
scale
ingly
wou
sphe

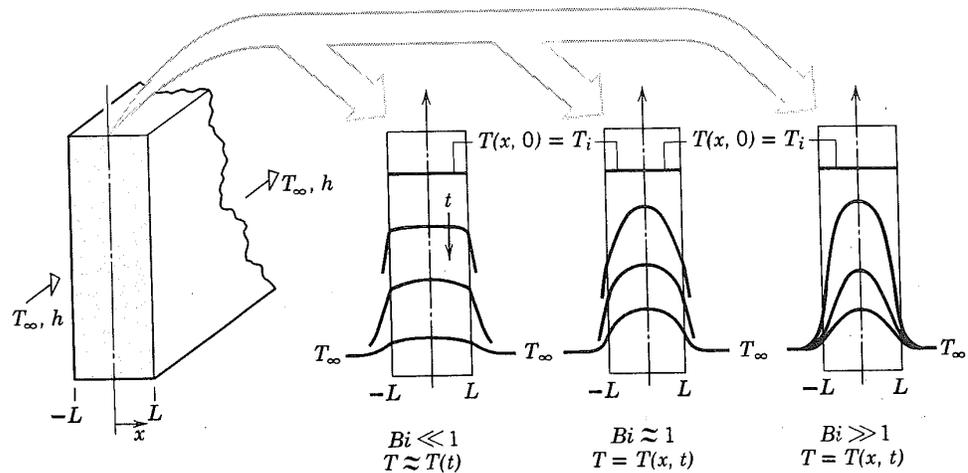

Figure 5.5 Transient temperature distribution for different Biot numbers in a plane wall symmetrically cooled by convection.

number, and three conditions are shown in Figure 5.5. For $Bi \ll 1$ the temperature gradient in the solid is small and $T(x, t) \approx T(t)$. Virtually all the temperature difference is between the solid and the fluid, and the solid temperature remains nearly uniform as it decreases to T_∞ . For moderate to large values of the Biot number, however, the temperature gradients within the solid are significant. Hence $T = T(x, t)$. Note that for $Bi \gg 1$, the temperature difference across the solid is now much larger than that between the surface and the fluid.

We conclude this section by emphasizing the importance of the lumped capacitance method. Its inherent simplicity renders it the preferred method for solving transient conduction problems. Hence, when confronted with such a problem, *the very first thing that one should do is calculate the Biot number*. If the following condition is satisfied

$$Bi = \frac{hL_c}{k} < 0.1 \tag{5.10}$$

the error associated with using the lumped capacitance method is small. For convenience, it is customary to define the *characteristic length* of Equation 5.10 as the ratio of the solid's volume to surface area, $L_c \equiv V/A_s$. Such a definition facilitates calculation of L_c for solids of complicated shape and reduces to the half-thickness L for a plane wall of thickness $2L$ (Figure 5.5), to $r_o/2$ for a long cylinder, and to $r_o/3$ for a sphere. However, if one wishes to implement the criterion in a conservative fashion, L_c should be associated with the length scale corresponding to the maximum spatial temperature difference. Accordingly, for a symmetrically heated (or cooled) plane wall of thickness $2L$, L_c would remain equal to the half-thickness L . However, for a long cylinder or sphere, L_c would equal the actual radius r_o , rather than $r_o/2$ or $r_o/3$.

umber on
istribution in a
ction.

steady-state

hen obtain

$$(5.9)$$

less param-
al role in
ording to
provides a
emperature
conditions
itions, it is
olid at any
iated with
, Equation
ss than the
mption of

ificance to
5, which is
oling when
ed as one
ation with
f the Biot

Finally, we note that, with $L_c \equiv V/A_s$, the exponent of Equation 5.6 may be expressed as

$$\frac{hA_s t}{\rho V c} = \frac{ht}{\rho c L_c} = \frac{hL_c}{k} \frac{k}{\rho c} \frac{t}{L_c^2} = \frac{hL_c}{k} \frac{\alpha t}{L_c^2}$$

or

$$\frac{hA_s t}{\rho V c} = Bi \cdot Fo \tag{5.11}$$

where

$$Fo \equiv \frac{\alpha t}{L_c^2} \tag{5.12}$$

is termed the Fourier number. It is a *dimensionless time*, which, with the Biot number, characterizes transient conduction problems. Substituting Equation 5.11 into 5.6, we obtain

$$\frac{\theta}{\theta_i} = \frac{T - T_\infty}{T_i - T_\infty} = \exp(-Bi \cdot Fo) \tag{5.13}$$

EXAMPLE 5.1

A thermocouple junction, which may be approximated as a sphere, is to be used for temperature measurement in a gas stream. The convection coefficient between the junction surface and the gas is known to be $h = 400 \text{ W/m}^2 \cdot \text{K}$, and the junction thermophysical properties are $k = 20 \text{ W/m} \cdot \text{K}$, $c = 400 \text{ J/kg} \cdot \text{K}$, and $\rho = 8500 \text{ kg/m}^3$. Determine the junction diameter needed for the thermocouple to have a time constant of 1 s. If the junction is at 25°C and is placed in a gas stream that is at 200°C , how long will it take for the junction to reach 199°C ?

SOLUTION

Known: Thermophysical properties of thermocouple junction used to measure temperature of a gas stream.

Find:

1. Junction diameter needed for a time constant of 1 s.
2. Time required to reach 199°C in gas stream at 200°C .

Schem

$$T_\infty = 200^\circ\text{C}$$

$$h = 400 \text{ W/m}^2 \cdot \text{K}$$

Gas s

Assum

1. T
2. R
3. L
4. C

Analy

1. B
- tl
- c
- a
- d
- f

tion 5.6 may

Schematic:

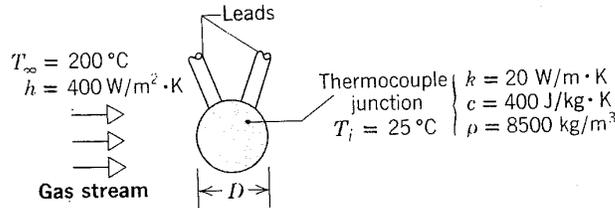

(5.11)

Assumptions:

1. Temperature of junction is uniform at any instant.
2. Radiation exchange with the surroundings is negligible.
3. Losses by conduction through the leads are negligible.
4. Constant properties.

Analysis:

1. Because the junction diameter is unknown, it is not possible to begin the solution by determining whether the criterion for using the lumped capacitance method, Equation 5.10, is satisfied. However, a reasonable approach is to use the method to find the diameter and to then determine whether the criterion is satisfied. From Equation 5.7 and the fact that $A_s = \pi D^2$ and $V = \pi D^3/6$ for a sphere, it follows that

$$\tau_t = \frac{1}{h\pi D^2} \times \frac{\rho\pi D^3}{6} c$$

Rearranging and substituting numerical values,

$$D = \frac{6h\tau_t}{\rho c} = \frac{6 \times 400 \text{ W/m}^2 \cdot \text{K} \times 1 \text{ s}}{8500 \text{ kg/m}^3 \times 400 \text{ J/kg} \cdot \text{K}} = 7.06 \times 10^{-4} \text{ m} \quad \triangleleft$$

With $L_c = r_o/3$ it then follows from Equation 5.10 that

$$Bi = \frac{h(r_o/3)}{k} = \frac{400 \text{ W/m}^2 \cdot \text{K} \times 3.53 \times 10^{-4} \text{ m}}{3 \times 20 \text{ W/m} \cdot \text{K}} = 2.35 \times 10^{-4}$$

Accordingly, Equation 5.10 is satisfied (for $L_c = r_o$, as well as for $L_c = r_o/3$) and the lumped capacitance method may be used to an excellent approximation.

(5.12)

with the Biot
ing Equation

(5.13)

ere, is to be
n coefficient
 $\text{W/m}^2 \cdot \text{K}$,
 K , $c = 400$
needed for
at 25°C and
the junction

l to mea-

2. From Equation 5.5 the time required for the junction to reach $T = 199^\circ\text{C}$ is

$$t = \frac{\rho(\pi D^3/6)c}{h(\pi D^2)} \ln \frac{T_i - T_\infty}{T - T_\infty} = \frac{\rho D c}{6h} \ln \frac{T_i - T_\infty}{T - T_\infty}$$

$$t = \frac{8500 \text{ kg/m}^3 \times 7.06 \times 10^{-4} \text{ m} \times 400 \text{ J/kg} \cdot \text{K}}{6 \times 400 \text{ W/m}^2 \cdot \text{K}} \ln \frac{25 - 200}{199 - 200}$$

$$t = 5.2 \text{ s} \approx 5\tau_t \quad \triangleleft$$

Comments: Heat losses due to radiation exchange between the junction and the surroundings and conduction through the leads would necessitate using a smaller junction diameter to achieve the desired time response.

5.3 GENERAL LUMPED CAPACITANCE ANALYSIS

Although transient conduction in a solid is commonly initiated by convection heat transfer to or from an adjoining fluid, other processes may induce transient thermal conditions within the solid. For example, a solid may be separated from large surroundings by a gas or vacuum. If the temperatures of the solid and surroundings differ, radiation exchange could cause the internal thermal energy, and hence the temperature, of the solid to change. Temperature changes could also be induced by applying a heat flux at a portion, or all, of the surface and/or by initiating thermal energy generation within the solid. Surface heating could, for example, be applied by attaching a film or sheet electrical heater to the surface, while thermal energy could be generated by passing an electrical current through the solid.

Figure 5.6 depicts a situation for which thermal conditions within a solid may be simultaneously influenced by convection, radiation, an applied surface

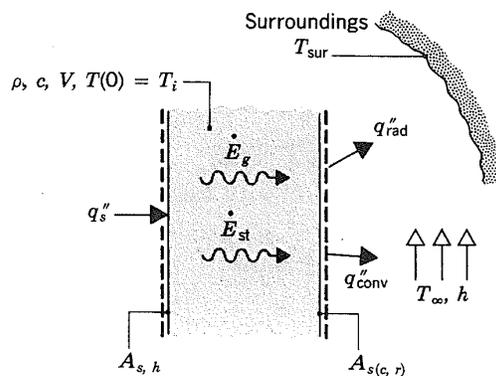

Figure 5.6 Contral surface for general lumped capacitance analysis.

heat fl
the ter
surrou
are ini
transfe
respec
surfac
Equati

q

or, fr

q

U

neous
exact
versio
gener
relati

f

Separ
follow

Evalu
temp

This
 T_{sur}

deriv

each $T =$

$$\frac{-200}{1-200}$$

◁

junction
necessitate
muse.

convection
may induce
lid may be
temperatures of
the internal
. Tempera-
tion, or all,
n the solid.
m or sheet
nerated by

thin a solid
ied surface

heat flux, and internal energy generation. It is presumed that, initially ($t = 0$), the temperature of the solid (T_i) differs from that of the fluid, T_∞ , and the surroundings, T_{sur} , and that both surface and volumetric heating (q_s'' and \dot{q}) are initiated. The imposed heat flux q_s'' and the convection–radiation heat transfer occur at mutually exclusive portions of the surface, $A_{s(h)}$ and $A_{s(c,r)}$, respectively, and convection–radiation transfer is presumed to be from the surface. Applying conservation of energy at any instant t , it follows from Equation 1.11a that

$$q_s'' A_{s,h} + \dot{E}_g - (q_{\text{conv}}'' + q_{\text{rad}}'') A_{s(c,r)} = \rho V c \frac{dT}{dt} \quad (5.14)$$

or, from Equations 1.3a and 1.7,

$$q_s'' A_{s,h} + \dot{E}_g - [h(T - T_\infty) + \varepsilon\sigma(T^4 - T_{\text{sur}}^4)] A_{s(c,r)} = \rho V c \frac{dT}{dt} \quad (5.15)$$

Unfortunately, Equation 5.15 is a nonlinear, first-order, nonhomogeneous, ordinary differential equation which cannot be integrated to obtain an exact solution.¹ However, exact solutions may be obtained for simplified versions of the equation. For example, if there is no imposed heat flux or generation and convection is either nonexistent (a vacuum) or negligible relative to radiation, Equation 5.15 reduces to

$$\rho V c \frac{dT}{dt} = -\varepsilon A_{s,r} \sigma (T^4 - T_{\text{sur}}^4) \quad (5.16)$$

Separating variables and integrating from the initial condition to any time t , it follows that

$$\frac{\varepsilon A_{s,r} \sigma}{\rho V c} \int_0^t dt = \int_{T_i}^T \frac{dT}{T_{\text{sur}}^4 - T^4} \quad (5.17)$$

Evaluating both integrals and rearranging, the time required to reach the temperature T becomes

$$t = \frac{\rho V c}{4\varepsilon A_{s,r} \sigma T_{\text{sur}}^3} \left\{ \ln \left| \frac{T_{\text{sur}} + T}{T_{\text{sur}} - T} \right| - \ln \left| \frac{T_{\text{sur}} + T_i}{T_{\text{sur}} - T_i} \right| + 2 \left[\tan^{-1} \left(\frac{T}{T_{\text{sur}}} \right) - \tan^{-1} \left(\frac{T_i}{T_{\text{sur}}} \right) \right] \right\} \quad (5.18)$$

This expression cannot be used to evaluate T explicitly in terms of t , T_i , and T_{sur} , nor does it readily reduce to the limiting result for $T_{\text{sur}} = 0$ (radiation to

¹ An approximate, finite-difference solution may be obtained by *discretizing* the time derivative (Section 5.9) and *marching* the solution out in time.

deep space). Returning to Equation 5.17, it is readily shown that, for $T_{\text{sur}} = 0$,

$$t = \frac{\rho V c}{3 \varepsilon A_{s, \sigma}} \left(\frac{1}{T^3} - \frac{1}{T_i^3} \right) \quad (5.19)$$

An exact solution to Equation 5.15 may also be obtained if radiation may be neglected and h is independent of time. Introducing a reduced temperature, $\theta \equiv T - T_{\infty}$, where $d\theta/dt = dT/dt$, Equation 5.15 reduces to a linear, first-order, nonhomogeneous differential equation of the form

$$\frac{d\theta}{dt} + a\theta - b = 0 \quad (5.20)$$

where $a \equiv (hA_{s, c}/\rho V c)$ and $b \equiv [(q_s'' A_{s, h} + \dot{E}_g)/\rho V c]$. Although Equation 5.20 may be solved by summing its homogeneous and particular solutions, an alternative approach is to eliminate the nonhomogeneity by introducing the transformation

$$\theta' \equiv \theta - \frac{b}{a} \quad (5.21)$$

Recognizing that $d\theta'/dt = d\theta/dt$, Equation 5.21 may be substituted into (5.20) to yield

$$\frac{d\theta'}{dt} + a\theta' = 0 \quad (5.22)$$

Separating variables and integrating from 0 to t (θ'_i to θ'), it follows that

$$\frac{\theta'}{\theta'_i} = \exp(-at) \quad (5.23)$$

or substituting for θ' and θ ,

$$\frac{T - T_{\infty} - (b/a)}{T_i - T_{\infty} - (b/a)} = \exp(-at) \quad (5.24)$$

Hence,

$$\frac{T - T_{\infty}}{T_i - T_{\infty}} = \exp(-at) + \frac{b/a}{T_i - T_{\infty}} [1 - \exp(-at)] \quad (5.25)$$

As it must, Equation 5.25 reduces to (5.6) when $b = 0$ and yields $T = T_i$ at $t = 0$. As $t \rightarrow \infty$, Equation 5.25 reduces to $(T - T_{\infty}) = (b/a)$, which could also be obtained by performing an energy balance on the control surface of Figure 5.6 for steady-state conditions.

5.4 SPATIAL

Situati
propr
form c
mediu

In
by the
2.20 a
soluti
peratu
proble
neede
genera
2.13 t

7
neces
typica

and t

and

Equa
Equa
and
Fror
and
ters.

metl
note

for $T_{\text{sur}} = 0$,

$$(5.19)$$

radiation may
temperature,
linear, first-

$$(5.20)$$

gh Equation
solutions, an
roducing the

$$(5.21)$$

stituted into

$$(5.22)$$

ows that

$$(5.23)$$

$$(5.24)$$

$$(5.25)$$

s $T = T_i$ at
which could
l surface of

5.4 SPATIAL EFFECTS

Situations frequently arise for which the lumped capacitance method is inappropriate, and alternative methods must be used. Regardless of the particular form of the method, we must now cope with the fact that gradients within the medium are no longer negligible.

In their most general form, transient conduction problems are described by the heat equation, Equation 2.13 for rectangular coordinates or Equations 2.20 and 2.23, respectively, for cylindrical and spherical coordinates. The solution to these partial differential equations provides the variation of temperature with both time and the spatial coordinates. However, in many problems, such as the plane wall of Figure 5.5, only one spatial coordinate is needed to describe the internal temperature distribution. With no internal generation and the assumption of constant thermal conductivity, Equation 2.13 then reduces to

$$\frac{\partial^2 T}{\partial x^2} = \frac{1}{\alpha} \frac{\partial T}{\partial t} \quad (5.26)$$

To solve Equation 5.26 for the temperature distribution $T(x, t)$, it is necessary to specify an *initial* condition and two *boundary conditions*. For the typical transient conduction problem of Figure 5.5, the initial condition is

$$T(x, 0) = T_i \quad (5.27)$$

and the boundary conditions are

$$\left. \frac{\partial T}{\partial x} \right|_{x=0} = 0 \quad (5.28)$$

and

$$-k \left. \frac{\partial T}{\partial x} \right|_{x=L} = h [T(L, t) - T_\infty] \quad (5.29)$$

Equation 5.27 presumes a uniform temperature distribution at time $t = 0$; Equation 5.28 reflects the *symmetry requirement* for the midplane of the wall; and Equation 5.29 describes the surface condition experienced for time $t > 0$. From Equations 5.26 to 5.29, it is evident that, in addition to depending on x and t , temperatures in the wall also depend on a number of physical parameters. In particular

$$T = T(x, t, T_i, T_\infty, L, k, \alpha, h) \quad (5.30)$$

The foregoing problem may be solved analytically or numerically. These methods will be considered in subsequent sections, but first it is important to note the advantages that may be obtained by *nondimensionalizing* the govern-

ing equations. This may be done by arranging the relevant variables into suitable *groups*. Consider the dependent variable T . If the temperature difference $\theta \equiv T - T_\infty$ is divided by the *maximum possible temperature difference* $\theta_i \equiv T_i - T_\infty$, a dimensionless form of the dependent variable may be defined as

$$\theta^* \equiv \frac{\theta}{\theta_i} = \frac{T - T_\infty}{T_i - T_\infty} \quad (5.31)$$

Accordingly, θ^* must lie in the range $0 \leq \theta^* \leq 1$. A dimensionless spatial coordinate may be defined as

$$x^* \equiv \frac{x}{L} \quad (5.32)$$

where L is the half-thickness of the plane wall, and a dimensionless time may be defined as

$$t^* \equiv \frac{\alpha t}{L^2} \equiv Fo \quad (5.33)$$

where t^* is equivalent to the dimensionless *Fourier number*, Equation 5.12.

Substituting the definitions of Equations 5.31 to 5.33 into Equations 5.26 to 5.29, the heat equation becomes

$$\frac{\partial^2 \theta^*}{\partial x^{*2}} = \frac{\partial \theta^*}{\partial Fo} \quad (5.34)$$

and the initial and boundary conditions become

$$\theta^*(x^*, 0) = 1 \quad (5.35)$$

$$\left. \frac{\partial \theta^*}{\partial x^*} \right|_{x^*=0} = 0 \quad (5.36)$$

and

$$\left. \frac{\partial \theta^*}{\partial x^*} \right|_{x^*=1} = -Bi\theta^*(1, t^*) \quad (5.37)$$

where the Biot number is $Bi \equiv hL/k$. In dimensionless form the functional dependence may now be expressed as

$$\theta^* = f(x^*, Fo, Bi) \quad (5.38)$$

Recall that this functional dependence, without the x^* variation, was obtained for the lumped capacitance method, as shown in Equation 5.13.

Comparing Equations 5.30 and 5.38, the considerable advantage associated with casting the problem in dimensionless form becomes apparent.

Equal
distrib
solution
value
prese
are u

5.5 THI

Exac
taine
docu
the i
purp
tion,
very
singl

5.5.1 E

Con:
relat
conc
unif
 $T_\infty =$
subj
conc
tion



Fig
tem
wal

variables into
 ature differ-
 re difference
 y be defined

(5.31)

less spatial

(5.32)

ss time may

(5.33)

tion 5.12.
 uations 5.26

(5.34)

(5.35)

(5.36)

(5.37)

: functional

(5.38)

as obtained

tage associ-
 s apparent.

Equation 5.38 implies that for a prescribed geometry, the transient temperature distribution is a universal function of x^* , Fo , and Bi . That is, the dimensionless solution assumes a prescribed form that does not depend on the particular value of T_i , T_∞ , L , k , α , or h . Since this generalization greatly simplifies the presentation and utilization of transient solutions, the dimensionless variables are used extensively in subsequent sections.

5.5 THE PLANE WALL WITH CONVECTION

Exact, analytical solutions to transient conduction problems have been obtained for many simplified geometries and boundary conditions and are well documented in the literature [1-4]. Several mathematical techniques, including the method of separation of variables (Section 4.2), may be used for this purpose, and typically the solution for the dimensionless temperature distribution, Equation 5.38, is in the form of an infinite series. However, except for very small values of the Fourier number, this series may be approximated by a single term and the results may be represented in a convenient graphical form.

5.5.1 Exact Solution

Consider the *plane wall* of thickness $2L$ (Figure 5.7a). If the thickness is small relative to the width and height of the wall, it is reasonable to assume that conduction occurs exclusively in the x direction. If the wall is initially at a uniform temperature, $T(x, 0) = T_i$, and is suddenly immersed in a fluid of $T_\infty \neq T_i$, the resulting temperatures may be obtained by solving Equation 5.34 subject to the conditions of Equations 5.35 to 5.37. Since the convection conditions for the surfaces at $x^* = \pm 1$ are the same, the temperature distribution at any instant must be symmetrical about the midplane ($x^* = 0$). An

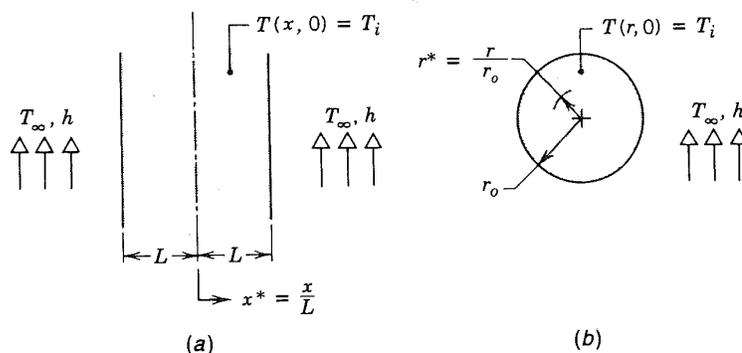

Figure 5.7 One-dimensional systems with an initial uniform temperature subjected to sudden convection conditions. (a) Plane wall. (b) Infinite cylinder or sphere.

exact solution to this problem has been obtained and is of the form [2]

$$\theta^* = \sum_{n=1}^{\infty} C_n \exp(-\zeta_n^2 Fo) \cos(\zeta_n x^*) \tag{5.39a}$$

where the coefficient C_n is

$$C_n = \frac{4 \sin \zeta_n}{2\zeta_n + \sin(2\zeta_n)} \tag{5.39b}$$

and the discrete values (*eigenvalues*) of ζ_n are positive roots of the transcendental equation

$$\zeta_n \tan \zeta_n = Bi \tag{5.39c}$$

The first four roots of this equation are given in Appendix B.3.

5.5.2 Approximate Solution

It can be shown (Problem 5.24) that for values of $Fo \geq 0.2$, the infinite series solution, Equation 5.39a, can be approximated by the first term of the series. Invoking this approximation, the dimensionless form of the temperature distribution becomes

$$\theta^* = C_1 \exp(-\zeta_1^2 Fo) \cos(\zeta_1 x^*) \tag{5.40a}$$

or

$$\theta^* = \theta_o^* \cos(\zeta_1 x^*) \tag{5.40b}$$

where θ_o^* represents the midplane ($x^* = 0$) temperature

$$\theta_o^* = C_1 \exp(-\zeta_1^2 Fo) \tag{5.41}$$

An important implication of Equation 5.40b is that *the time dependence of the temperature at any location within the wall is the same as that of the midplane temperature*. The coefficients C_1 and ζ_1 are evaluated from Equations 5.39b and 5.39c, respectively, and are given in Table 5.1 for a range of Biot numbers.

5.5.3 Total Energy Transfer

In many situations it is useful to know the total energy that has left the wall up to any time t in the transient process. The conservation of energy requirement, Equation 1.11b, may be applied for the time interval bounded by the initial condition ($t = 0$) and time $t > 0$

$$E_{in} - E_{out} = \Delta E_{st} \tag{5.42}$$

Table 5.

Bi^a

0.01
0.02
0.03
0.04
0.05
0.06
0.07
0.08
0.09
0.10
0.15
0.20
0.25
0.30
0.4
0.5
0.6
0.7
0.8
0.9
1.0
2.0
3.0
4.0
5.0
6.0
7.0
8.0
9.0
10.0
20.0
30.0
40.0
50.0
100.0

^a $Bi = h$.

m [2]

(5.39a)

(5.39b)

ie transcen-

(5.39c)

ifinite series
f the series.
temperature

(5.40a)

(5.40b)

(5.41)

vidence of the
he midplane
ations 5.39b
ot numbers.

left the wall
of energy
bounded by

(5.42)

Table 5.1 Coefficients used in the one-term approximation to the series solutions for transient one-dimensional conduction

Bi^a	PLANE WALL		INFINITE CYLINDER		SPHERE	
	ζ_1 (rad)	C_1	ζ_1 (rad)	C_1	ζ_1 (rad)	C_1
0.01	0.0998	1.0017	0.1412	1.0025	0.1730	1.0030
0.02	0.1410	1.0033	0.1995	1.0050	0.2445	1.0060
0.03	0.1732	1.0049	0.2439	1.0075	0.2989	1.0090
0.04	0.1987	1.0066	0.2814	1.0099	0.3450	1.0120
0.05	0.2217	1.0082	0.3142	1.0124	0.3852	1.0149
0.06	0.2425	1.0098	0.3438	1.0148	0.4217	1.0179
0.07	0.2615	1.0114	0.3708	1.0173	0.4550	1.0209
0.08	0.2791	1.0130	0.3960	1.0197	0.4860	1.0239
0.09	0.2956	1.0145	0.4195	1.0222	0.5150	1.0268
0.10	0.3111	1.0160	0.4417	1.0246	0.5423	1.0298
0.15	0.3779	1.0237	0.5376	1.0365	0.6608	1.0445
0.20	0.4328	1.0311	0.6170	1.0483	0.7593	1.0592
0.25	0.4801	1.0382	0.6856	1.0598	0.8448	1.0737
0.30	0.5218	1.0450	0.7465	1.0712	0.9208	1.0880
0.4	0.5932	1.0580	0.8516	1.0932	1.0528	1.1164
0.5	0.6533	1.0701	0.9408	1.1143	1.1656	1.1441
0.6	0.7051	1.0814	1.0185	1.1346	1.2644	1.1713
0.7	0.7506	1.0919	1.0873	1.1539	1.3525	1.1978
0.8	0.7910	1.1016	1.1490	1.1725	1.4320	1.2236
0.9	0.8274	1.1107	1.2048	1.1902	1.5044	1.2488
1.0	0.8603	1.1191	1.2558	1.2071	1.5708	1.2732
2.0	1.0769	1.1795	1.5995	1.3384	2.0288	1.4793
3.0	1.1925	1.2102	1.7887	1.4191	2.2889	1.6227
4.0	1.2646	1.2287	1.9081	1.4698	2.4556	1.7201
5.0	1.3138	1.2402	1.9898	1.5029	2.5704	1.7870
6.0	1.3496	1.2479	2.0490	1.5253	2.6537	1.8338
7.0	1.3766	1.2532	2.0937	1.5411	2.7165	1.8674
8.0	1.3978	1.2570	2.1286	1.5526	2.7654	1.8921
9.0	1.4149	1.2598	2.1566	1.5611	2.8044	1.9106
10.0	1.4289	1.2620	2.1795	1.5677	2.8363	1.9249
20.0	1.4961	1.2699	2.2881	1.5919	2.9857	1.9781
30.0	1.5202	1.2717	2.3261	1.5973	3.0372	1.9898
40.0	1.5325	1.2723	2.3455	1.5993	3.0632	1.9942
50.0	1.5400	1.2727	2.3572	1.6002	3.0788	1.9962
100.0	1.5552	1.2731	2.3809	1.6015	3.1102	1.9990

^a $Bi = hL/k$ for the plane wall and hr_o/k for the infinite cylinder and sphere. See Figure 5.7.

Equating the energy transferred from the wall Q to E_{out} and setting $E_{\text{in}} = 0$ and $\Delta E_{\text{st}} = E(t) - E(0)$, it follows that

$$Q = -[E(t) - E(0)] \quad (5.43a)$$

or

$$Q = -\int \rho c [T(r, t) - T_i] dV \quad (5.43b)$$

where the integration is performed over the volume of the wall. It is convenient to nondimensionalize this result by introducing the quantity

$$Q_o = \rho c V (T_i - T_\infty) \quad (5.44)$$

which may be interpreted as the initial internal energy of the wall relative to the fluid temperature. It is also the *maximum* amount of energy transfer which could occur if the process were continued to time $t = \infty$. Hence, assuming constant properties, the ratio of the total energy transferred from the wall over the time interval t to the maximum possible transfer is

$$\frac{Q}{Q_o} = \int \frac{-[T(r, t) - T_i]}{T_i - T_\infty} \frac{dV}{V} = \frac{1}{V} \int (1 - \theta^*) dV \quad (5.45)$$

Employing the approximate form of the temperature distribution for the plane wall, Equation 5.40b, the integration prescribed by Equation 5.45 can be performed to obtain

$$\frac{Q}{Q_o} = 1 - \frac{\sin \zeta_1}{\zeta_1} \theta_o^* \quad (5.46)$$

where θ_o^* can be determined from Equation 5.41, using Table 5.1 for values of the coefficients C_1 and ζ_1 .

5.5.4 Graphical Representations

Graphical representations of the *approximate* relations for the transient temperature distribution and energy transfer were first presented by Heisler [5] and Gröber et al. [6]. The graphs have been widely used for nearly four decades; in addition to offering computational convenience, they illustrate the functional dependence of the transient, dimensionless temperature distribution on the Biot and Fourier numbers.

Results for the plane wall are presented in Figures 5.8 to 5.10. Figure 5.8 may be used to obtain the *midplane* temperature of the wall, $T(0, t) = T_o(t)$, at any time during the transient process. If T_o is known for particular values of Fo and Bi , Figure 5.9 may be used to determine the corresponding temperature at any location *off the midplane*. Hence, Figure 5.9 must be used

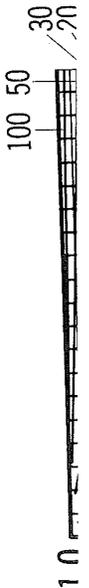

ing $E_{in} = 0$

(5.43a)

(5.43b)

It is conve-

(5.44)

l relative to
nsfer which
e, assuming
ie wall over

(5.45)

or the plane
.45 can be

(5.46)

or values of

nsient tem-
Heisler [5]
nearly four
illustrate the
distribution

. Figure 5.8
 $T(t) = T_o(t)$,
cular values
responding
ust be used

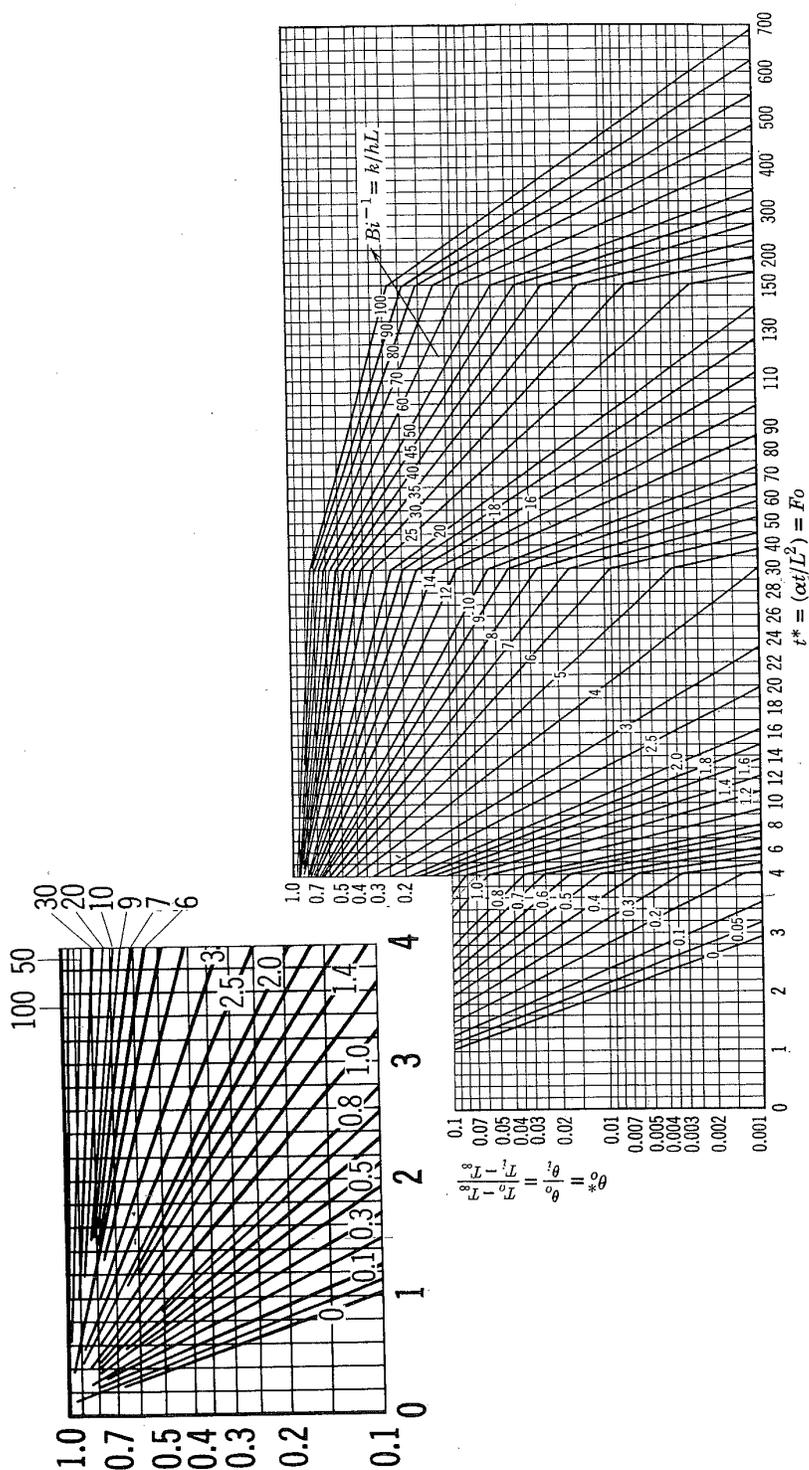

Figure 5.8 Midplane temperature as a function of time for a plane wall of thickness $2L$ [5]. Used with permission.

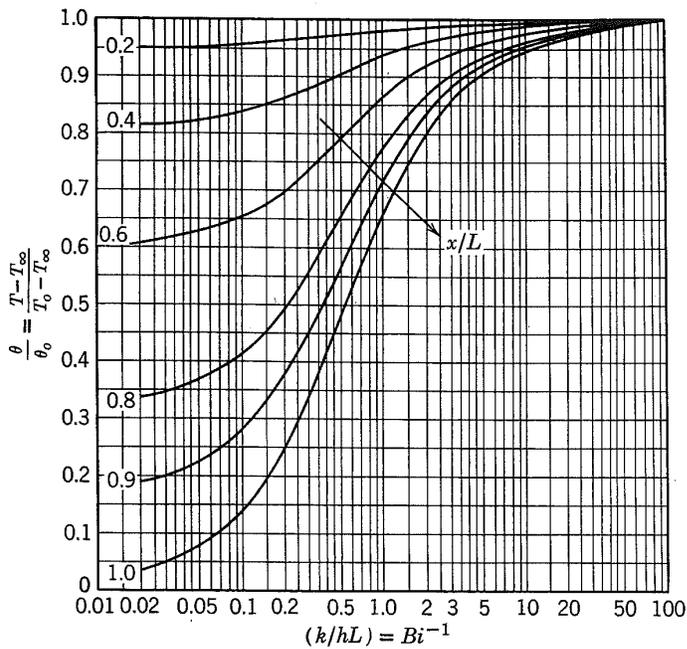

Figure 5.9 Temperature distribution in a plane wall of thickness $2L$ [5]. Used with permission.

in conjunction with Figure 5.8. For example, if one wishes to determine the surface temperature ($x^* = \pm 1$) at some time t , Figure 5.8 would first be used to determine T_o at t . Figure 5.9 would then be used to determine the surface temperature from knowledge of T_o . The procedure would be inverted if the problem were one of determining the time required for the surface to reach a prescribed temperature.

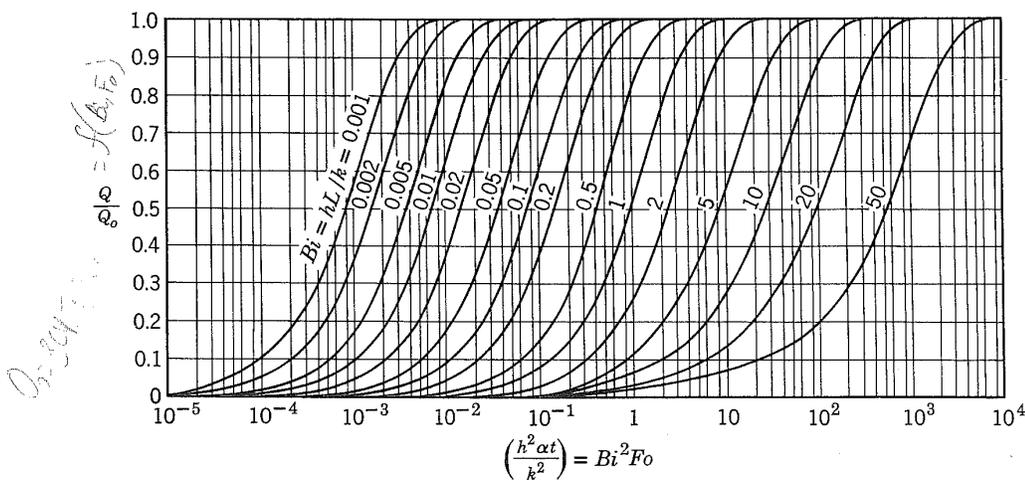

Figure 5.10 Internal energy change as a function of time for a plane wall of thickness $2L$ [6]. Adapted with permission.

depe
depe
quen
the ϵ

time
Equ:
sivel

resu
on c
(x^*
whe
the 1

5.6 RA

For
initi
resu
serio
ture
and
The
dim
tion

5.6.1 I

Exa
hav
init
as 1

Inf

Absence of the Fourier number in Figure 5.9 implies that the time dependence of any temperature off the midplane corresponds to the time dependence of the midplane temperature. This result is, of course, a consequence of the approximation that led to Equation 5.40b and is valid for all but the earliest stages of the transient process ($Fo \geq 0.2$).

Graphical results for the energy transferred from a plane wall over the time interval t are presented in Figure 5.10. These results were generated from Equation 5.46. The dimensionless energy transfer Q/Q_o is expressed exclusively in terms of Fo and Bi .

Because the mathematical problem is precisely the same, the foregoing results may also be applied to a plane wall of thickness L , which is insulated on one side ($x^* = 0$) and experiences convective transport on the other side ($x^* = +1$). This equivalence is a consequence of the fact that, regardless of whether a symmetrical or an adiabatic requirement is prescribed at $x^* = 0$, the boundary condition is of the form $\partial\theta^*/\partial x^* = 0$.

5.6 RADIAL SYSTEMS WITH CONVECTION

For an infinite cylinder or sphere of radius r_o (Figure 5.7b), which is at an initial uniform temperature and experiences a change in convective conditions, results similar to those of Section 5.5 may be developed. That is, an exact series solution may be obtained for the time dependence of the radial temperature distribution; a one-term approximation may be used for most conditions; and the approximation may be conveniently represented in graphical form. The infinite cylinder is an idealization that permits the assumption of one-dimensional conduction in the radial direction. It is a reasonable approximation for cylinders having $L/r_o \geq 10$.

5.6.1 Exact Solutions

Exact solutions to the transient, one-dimensional form of the heat equation have been developed for the infinite cylinder and for the sphere. For a uniform initial temperature and convective boundary conditions, the solutions [2] are as follows.

Infinite Cylinder In dimensionless form, the temperature is

$$\theta^* = \sum_{n=1}^{\infty} C_n \exp(-\zeta_n^2 Fo) J_0(\zeta_n r^*) \tag{5.47a}$$

etermine the
st be used
he surface
rted if the
to reach a

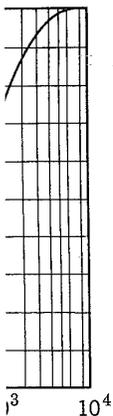

all of

where

$$C_n = \frac{2 J_1(\zeta_n)}{\zeta_n J_0^2(\zeta_n) + J_1^2(\zeta_n)} \quad (5.47b)$$

and the discrete values of ζ_n are positive roots of the transcendental equation

$$\zeta_n \frac{J_1(\zeta_n)}{J_0(\zeta_n)} = Bi \quad (5.47c)$$

The quantities J_1 and J_0 are Bessel functions of the first kind and their values are tabulated in Appendix B.4. Roots of the transcendental equation (5.47c) are tabulated by Schneider [2].

Sphere Similarly, for the sphere

$$\theta^* = \sum_{n=1}^{\infty} C_n \exp(-\zeta_n^2 Fo) \frac{1}{\zeta_n r^*} \sin(\zeta_n r^*) \quad (5.48a)$$

where

$$C_n = \frac{4[\sin(\zeta_n) - \zeta_n \cos(\zeta_n)]}{2\zeta_n - \sin(2\zeta_n)} \quad (5.48b)$$

and the discrete values of ζ_n are positive roots of the transcendental equation

$$1 - \zeta_n \cot \zeta_n = Bi \quad (5.48c)$$

Roots of the transcendental equation are tabulated by Schneider [2].

5.6.2 Approximate Solutions

For the infinite cylinder and sphere, Heisler [5] has shown that for $Fo \geq 0.2$, the foregoing series solutions can be approximated by a single term. Hence, as for the case of the plane wall, the time dependence of the temperature at any location within the radial system is the same as that of the centerline or centerpoint.

Infinite Cylinder The one-term approximation to Equation 5.47 is

$$\theta^* = C_1 \exp(-\zeta_1^2 Fo) J_0(\zeta_1 r^*) \quad (5.49a)$$

or

$$\theta^* = \theta_o^* J_0(\zeta_1 r^*) \quad (5.49b)$$

where

$$\theta_o^*$$

Values
Table

Sphere

$$\theta^*$$

or

$$\theta$$

where

$$\theta$$

Value
Table

5.6.3 To

As in
total
 $\Delta t =$
5.50b

Infini

Sphe

Valu
5.50c

where θ_o^* represents the centerline temperature and is of the form

$$\theta_o^* = C_1 \exp(-\zeta_1^2 Fo) \quad (5.49c)$$

Values of the coefficients C_1 and ζ_1 have been determined and are listed in Table 5.1 for a range of Biot numbers.

Sphere From Equation 5.48a, the one-term approximation is

$$\theta^* = C_1 \exp(-\zeta_1^2 Fo) \frac{1}{\zeta_1 r^*} \sin(\zeta_1 r^*) \quad (5.50a)$$

or

$$\theta^* = \theta_o^* \frac{1}{\zeta_1 r^*} \sin(\zeta_1 r^*) \quad (5.50b)$$

where θ_o^* represents the center temperature and is of the form

$$\theta_o^* = C_1 \exp(-\zeta_1^2 Fo) \quad (5.50c)$$

Values of the coefficients C_1 and ζ_1 have been determined and are listed in Table 5.1 for a range of Biot numbers.

5.6.3 Total Energy Transfer

As in Section 5.5.3, an energy balance may be performed to determine the total energy transfer from the infinite cylinder or sphere over the time interval $\Delta t = t$. Substituting from the approximate solutions, Equations 5.49b and 5.50b, and introducing Q_o from Equation 5.44, the results are as follows.

Infinite Cylinder

$$\frac{Q}{Q_o} = 1 - \frac{2\theta_o^*}{\zeta_1} J_1(\zeta_1) \quad (5.51)$$

Sphere

$$\frac{Q}{Q_o} = 1 - \frac{3\theta_o^*}{\zeta_1^3} [\sin(\zeta_1) - \zeta_1 \cos(\zeta_1)] \quad (5.52)$$

Values of the center temperature θ_o^* are determined from Equation 5.49c or 5.50c, using the coefficients of Table 5.1 for the appropriate system.

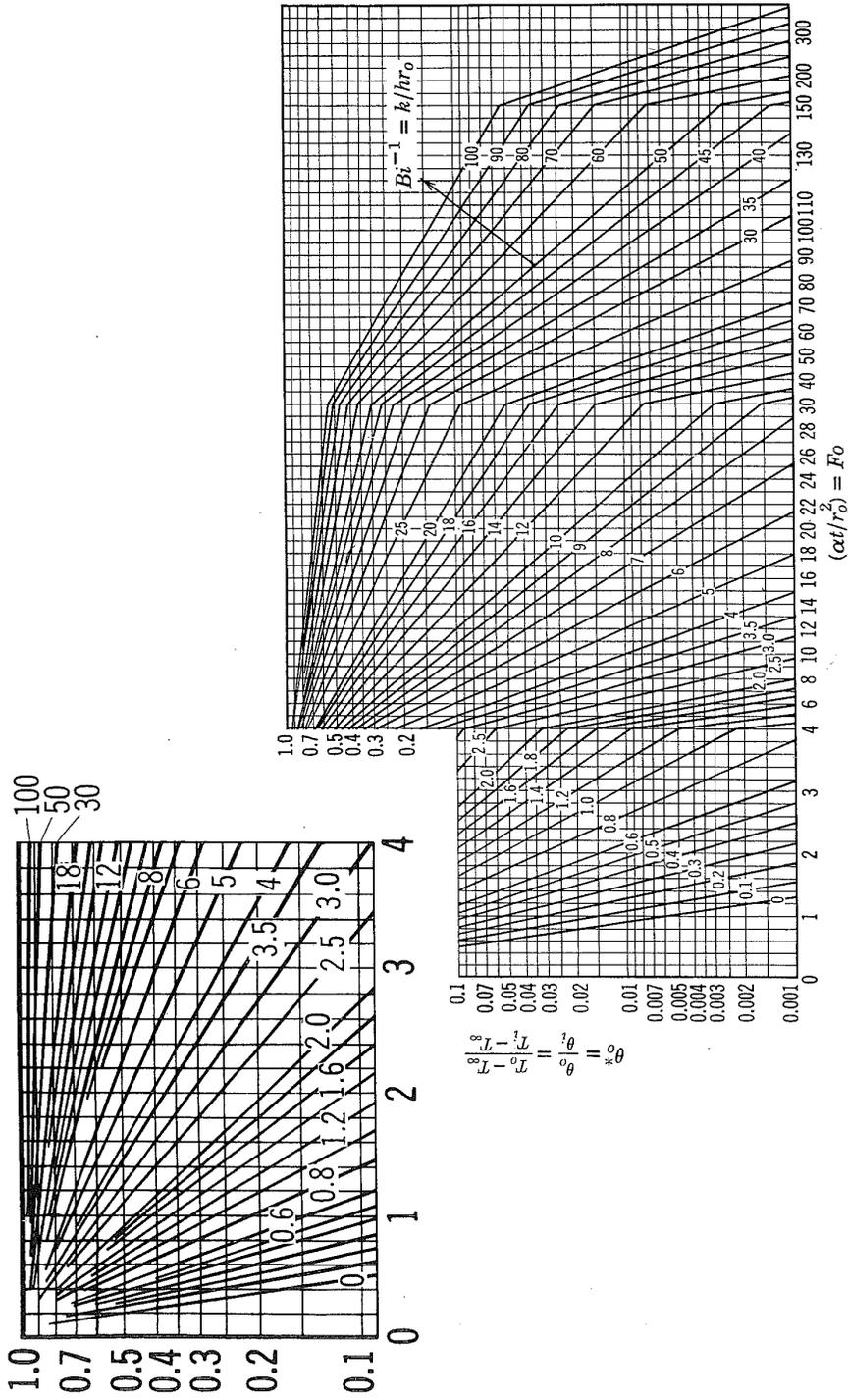

Figure 5.11 Centerline temperature as a function of time for an infinite cylinder of radius r_o [5]. Used with permission.

Figure of rad
 5.6.4 Gr
 Grap 5.10) infini
 Figu 5.16.
 1.0
 0.9
 0.8
 0.7
 0.6
 0.5
 0.4
 0.3
 0.2
 0.1
 (

0 1 2 3 4 6 8 10 12 14 16 18 20 22 24 26 28 30 40 50 60 70 80 90 100 110 130 150 200 300
 $(\alpha t/r_o^2) = Fo$

Figure 5.11 Centerline temperature as a function of time for an infinite cylinder of radius r_o [5]. Used with permission.

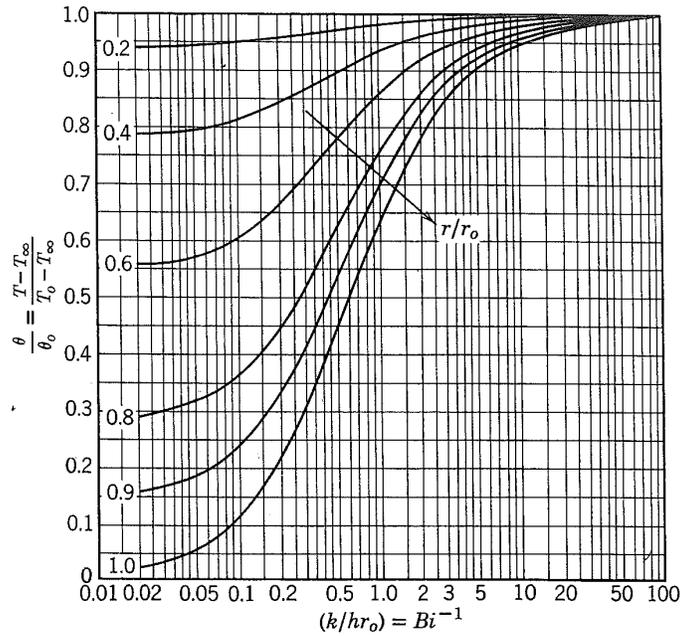

Figure 5.12 Temperature distribution in an infinite cylinder of radius r_o [5]. Used with permission.

5.6.4 Graphical Representation

Graphical representations similar to those for the plane wall (Figures 5.8 to 5.10) have also been generated by Heisler [5] and Gröber et al. [6] for an infinite cylinder and a sphere. Results for the infinite cylinder are presented in Figures 5.11 to 5.13, and those for the sphere are presented in Figures 5.14 to 5.16. Note that, with respect to the use of these figures, the Biot number is

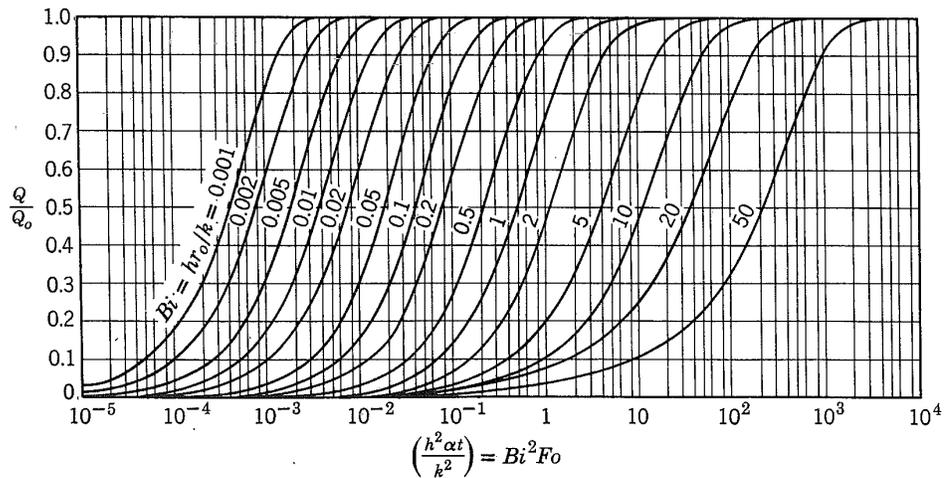

Figure 5.13 Internal energy change as a function of time for an infinite cylinder of radius r_o [6]. Adapted with permission.

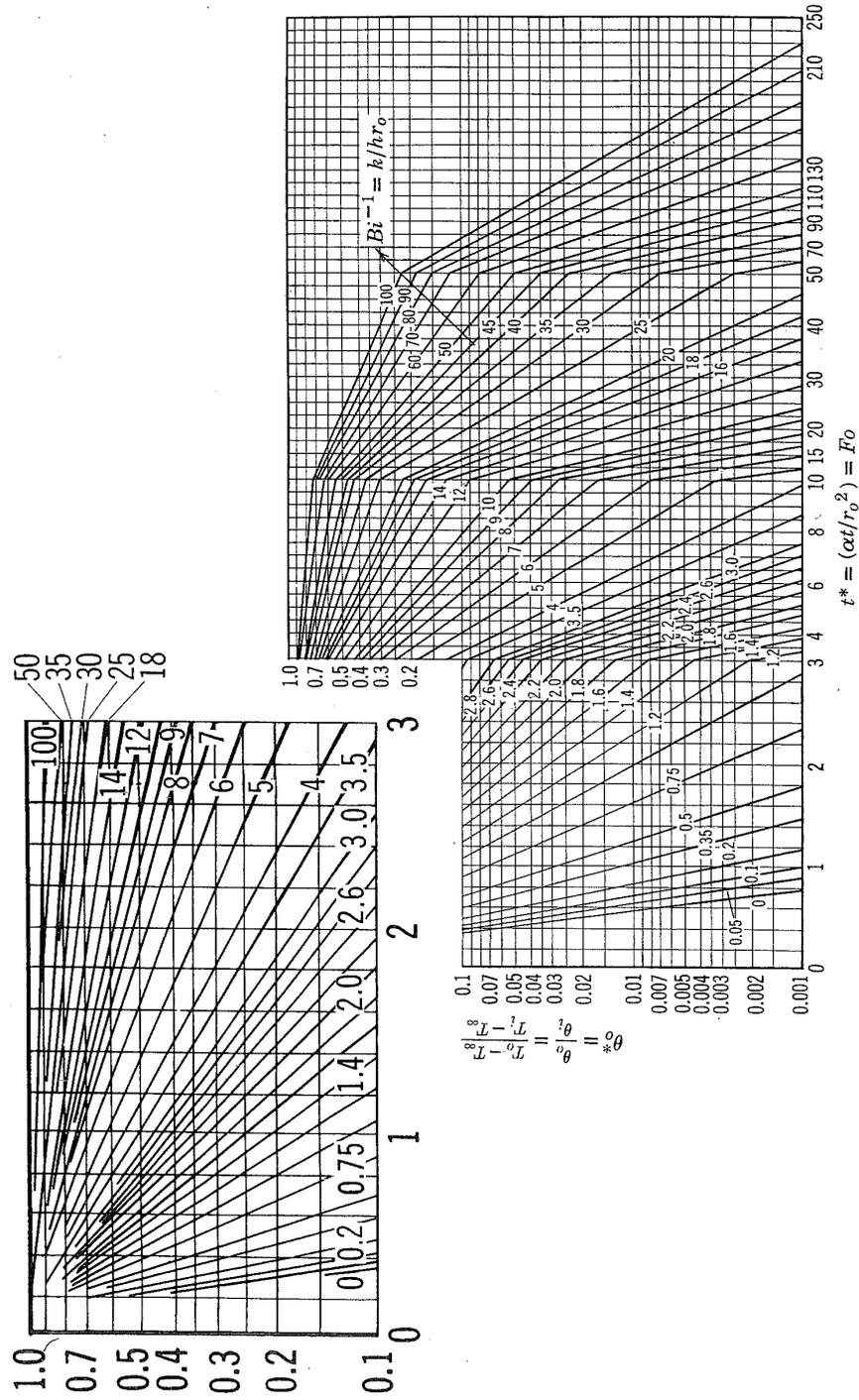

Figure 5.14 Center temperature as a function of time in a sphere of radius r_0 [5]. Used with permission.

$$\frac{\theta}{\theta_0} = \frac{T - T_\infty}{T_0 - T_\infty}$$

Figure 5.15

define the cylinder

define the sphere

$$\frac{\theta}{\theta_0}$$

Figure 5.16

290
280
270
260
250
240
230
220
210
200
190
180
170
160
150
140
130
120
110
100
90
80
70
60
50
40
30
20
10
0

Figure 5.14 Center temperature as a function of time in a sphere of radius r_o [5]. Used with permission.

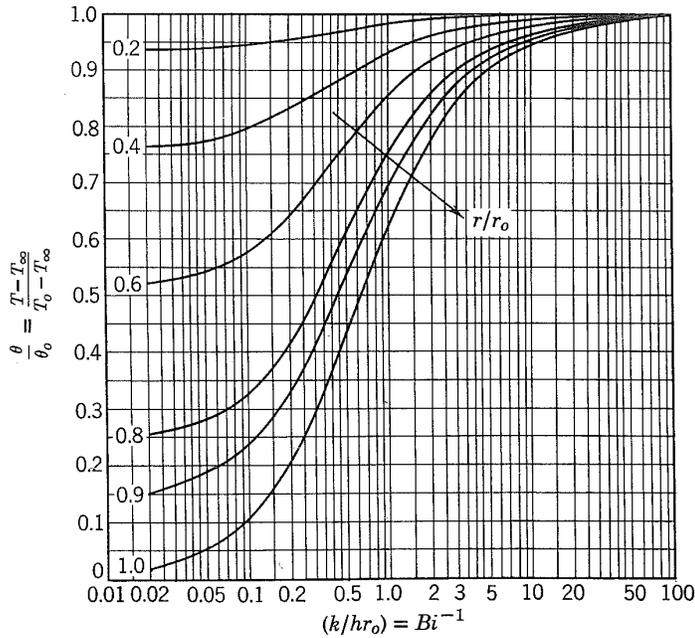

Figure 5.15 Temperature distribution in a sphere of radius r_o [5]. Used with permission.

defined in terms of r_o . In contrast recall that, for the lumped capacitance method, the characteristic length in the Biot number is customarily defined as $r_o/2$ for the cylinder and $r_o/3$ for the sphere.

In closing it should be noted that the Heisler charts may also be used to determine the transient response of a plane wall, an infinite cylinder, or a sphere subjected to a sudden change in surface temperature. For such a

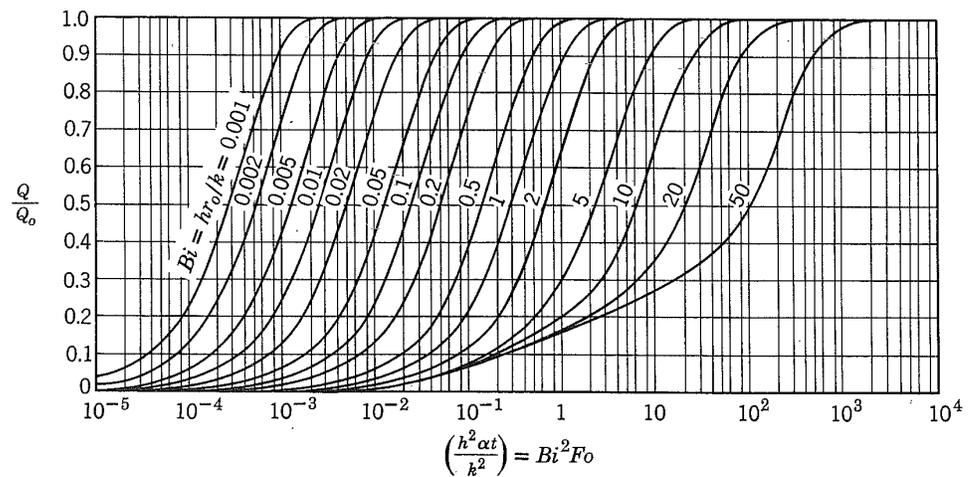

Figure 5.16 Internal energy change as a function of time for a sphere of radius r_o [6]. Adapted with permission.

condition it is only necessary to replace T_∞ by the prescribed surface temperature T_s and to set Bi^{-1} equal to zero. In so doing the convection coefficient is tacitly assumed to be infinite, in which case $T_\infty = T_s$.

EXAMPLE 5.2

Consider a steel pipeline (AISI 1010) that is 1 m in diameter and has a wall thickness of 40 mm. The pipe is heavily insulated on the outside, and before the initiation of flow, the walls of the pipe are at a uniform temperature of -20°C . With the initiation of flow, hot oil at 60°C is pumped through the pipe creating a convective surface condition corresponding to $h = 500 \text{ W/m}^2 \cdot \text{K}$ at the inner surface of the pipe.

1. What are the appropriate Biot and Fourier numbers 8 min after the initiation of flow?
2. At $t = 8 \text{ min}$, what is the temperature of the exterior pipe surface covered by the insulation?
3. What is the heat flux q'' (W/m^2) to the pipe from the oil at $t = 8 \text{ min}$?
4. How much energy per meter of pipe length has been transferred from the oil to the pipe at $t = 8 \text{ min}$?

SOLUTION

Known: Wall subjected to sudden change in convective surface condition.

Find:

1. Biot and Fourier numbers after 8 min.
2. Temperature of exterior pipe surface after 8 min.
3. Heat flux to the wall at 8 min.
4. Energy transferred to pipe per unit length after 8 min.

Schematic:

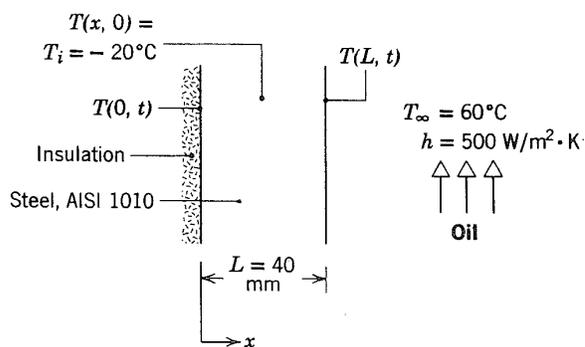

Assum

1. Pip
- les
2. Co
3. Ou

Proper

300 K
 $\alpha = 18$

Analys

1. At
- Ec

2. W
- at
- th
- ex
- of
- B,

H
ca

3. F
- ti
- F

1

tempera-
efficient is

as a wall
nd before
rature of
rough the
 $h = 500$

after the

re covered

= 8 min?

from the

dition.

Assumptions:

1. Pipe wall can be approximated as plane wall, since thickness is much less than diameter.
2. Constant properties.
3. Outer surface of pipe is adiabatic.

Properties: Table A.1, steel type AISI 1010 [$T = (-20 + 60)^\circ\text{C}/2 \approx 300 \text{ K}$]: $\rho = 7823 \text{ kg/m}^3$, $c = 434 \text{ J/kg} \cdot \text{K}$, $k = 63.9 \text{ W/m} \cdot \text{K}$, $\alpha = 18.8 \times 10^{-6} \text{ m}^2/\text{s}$.

Analysis:

1. At $t = 8 \text{ min}$, the Biot and Fourier numbers are computed from Equations 5.10 and 5.12, respectively, with $L_c = L$. Hence

$$Bi = \frac{hL}{k} = \frac{500 \text{ W/m}^2 \cdot \text{K} \times 0.04 \text{ m}}{63.9 \text{ W/m} \cdot \text{K}} = 0.313 \quad \triangleleft$$

$$Fo = \frac{\alpha t}{L^2} = \frac{18.8 \times 10^{-6} \text{ m}^2/\text{s} \times 8 \text{ min} \times 60 \text{ s/min}}{(0.04 \text{ m})^2} = 5.64 \quad \triangleleft$$

2. With $Bi = 0.313$, use of the lumped capacitance method is inappropriate. However, since transient conditions in the insulated pipe wall of thickness L correspond to those in a plane wall of thickness $2L$ experiencing the same surface condition, the desired results may be obtained from the charts for the plane wall. Using Figure 5.8, with $Bi^{-1} = 3.2$, it follows that

$$\frac{\theta_o}{\theta_i} = \frac{T(0, t) - T_\infty}{T_i - T_\infty} \approx 0.22$$

Hence after 8 min, the temperature of the exterior pipe surface, which corresponds to the midplane temperature of a plane wall, is

$$T_o = T(0, 480 \text{ s}) \approx T_\infty + 0.22(T_i - T_\infty)$$

$$T_o = 60^\circ\text{C} + 0.22(-20 - 60)^\circ\text{C} \approx 42^\circ\text{C} \quad \triangleleft$$

3. Heat transfer to the inner surface at $x = L$ is by convection, and at any time t the heat flux may be obtained from Newton's law of cooling. Hence at $t = 480 \text{ s}$,

$$q_x''(L, 480 \text{ s}) \equiv q_L'' = h[T(L, 480 \text{ s}) - T_\infty]$$

The surface temperature $T(L, 480 \text{ s})$ may be obtained from Figure 5.9.

For the prescribed conditions

$$\frac{x}{L} = 1 \quad \text{and} \quad Bi^{-1} = 3.2$$

it follows that

$$\frac{\theta(L, 480 \text{ s})}{\theta_o(480 \text{ s})} = \frac{T(L, 480 \text{ s}) - T_\infty}{T_o(480 \text{ s}) - T_\infty} \approx 0.86$$

Hence

$$T(L, 480 \text{ s}) \approx T_\infty + 0.86[T_o(480 \text{ s}) - T_\infty]$$

$$T(L, 480 \text{ s}) \approx 60^\circ\text{C} + 0.86[42 - 60]^\circ\text{C} \approx 45^\circ\text{C}$$

The heat flux at $t = 8 \text{ min}$ is then

$$q''_L = 500 \text{ W/m}^2 \cdot \text{K} (45 - 60)^\circ\text{C} = -7500 \text{ W/m}^2 \quad \triangleleft$$

4. The energy transfer to the pipewall over the 8-min interval may be obtained from Figure 5.10 and Equation 5.44. With

$$Bi = 0.313 \quad Bi^2 Fo = 0.55$$

it follows that

$$\frac{Q}{Q_o} \approx 0.78$$

Hence

$$Q \approx 0.78 \rho c V (T_i - T_\infty)$$

or with a volume per unit pipe length of $V' = \pi DL$,

$$Q' \approx 0.78 \rho c \pi DL (T_i - T_\infty)$$

$$Q' \approx 0.78 \times 7823 \text{ kg/m}^3 \times 434 \text{ J/kg} \cdot \text{K} \\ \times \pi \times 1 \text{ m} \times 0.04 \text{ m} (-20 - 60)^\circ\text{C}$$

$$Q' \approx -2.7 \times 10^7 \text{ J/m} \quad \triangleleft$$

Comments:

1. The minus sign associated with q'' and Q' simply implies that the direction of heat transfer is from the oil to the pipe (into the pipe wall).
2. Since $Fo > 0.2$, the one-term approximation can be used to calculate wall temperatures and the total energy transfer. The midplane tempera-

tur

wh
Wi

Th
Fi

$T(0, 8$

wh

3. U:
tic

wl

4. Tl
m
E

w

EXAM

A ne
mater
furna
cooliu

ture can be determined from Equation 5.41

$$\theta_o^* = \frac{T_o - T_\infty}{T_i - T_\infty} = C_1 \exp(-\zeta_1^2 Fo)$$

where, with $Bi = 0.313$, $C_1 = 1.047$ and $\zeta_1 = 0.531$ rad from Table 5.1. With $Fo = 5.64$,

$$\theta_o^* = 1.047 \exp[-(0.531 \text{ rad})^2 \times 5.64] = 0.214$$

This result is in good agreement with the value of 0.22 obtained from Figure 5.8. Hence,

$$T(0, 8 \text{ min}) = T_\infty + \theta_o^*(T_i - T_\infty) = 60^\circ\text{C} + 0.214(-20 - 60)^\circ\text{C} = 42.9^\circ\text{C}$$

which is within 2% of the value determined from the Heisler chart.

3. Using the one-term approximation for the surface temperature, Equation 5.40b with $x^* = 1$ has the form

$$\theta^* = \theta_o^* \cos(\zeta_1)$$

$$T(L, t) = T_\infty + (T_i - T_\infty)\theta_o^* \cos(\zeta_1)$$

$$T(L, 8 \text{ min}) = 60^\circ\text{C} + (-20 - 60)^\circ\text{C} \times 0.214 \times \cos(0.531 \text{ rad})$$

$$T(L, 8 \text{ min}) = 45.2^\circ\text{C}$$

which is within 1% of the value determined from the Heisler chart.

4. The total energy transferred during the transient process can be determined from the result associated with the one-term approximation, Equation 5.46.

$$\frac{Q}{Q_o} = 1 - \frac{\sin(\zeta_1)}{\zeta_1} \theta_o^*$$

$$\frac{Q}{Q_o} = 1 - \frac{\sin(0.531 \text{ rad})}{0.531 \text{ rad}} \times 0.214 = 0.80$$

which is within 3% of the value determined from the Gröber chart.

EXAMPLE 5.3

A new process for treatment of a special material is to be evaluated. The material, a sphere of radius $r_o = 5$ mm, is initially in equilibrium at 400°C in a furnace. It is suddenly removed from the furnace and subjected to a two-step cooling process.

Step 1 Cooling in air at 20°C for a period of time t_a until the center temperature reaches a critical value, $T_a(0, t_a) = 335^\circ\text{C}$. For this situation, the convective heat transfer coefficient is $h_a = 10 \text{ W/m}^2 \cdot \text{K}$.

After the sphere has reached this critical temperature, the second step is initiated.

Step 2 Cooling in a well-stirred water bath at 20°C, with a convective heat transfer coefficient of $h_w = 6000 \text{ W/m}^2 \cdot \text{K}$.

The thermophysical properties of the material are $\rho = 3000 \text{ kg/m}^3$, $k = 20 \text{ W/m} \cdot \text{K}$, $c = 1000 \text{ J/kg} \cdot \text{K}$, and $\alpha = 6.66 \times 10^{-6} \text{ m}^2/\text{s}$.

1. Calculate the time t_a required for step 1 of the cooling process to be completed.
2. Calculate the time t_w required during step 2 of the process for the center of the sphere to cool from 335°C (the condition at the completion of step 1) to 50°C.

SOLUTION

Known: Temperature requirements for cooling a sphere.

Find:

1. Time t_a required to accomplish desired cooling in air.
2. Time t_w required to complete cooling in water bath.

Schematic:

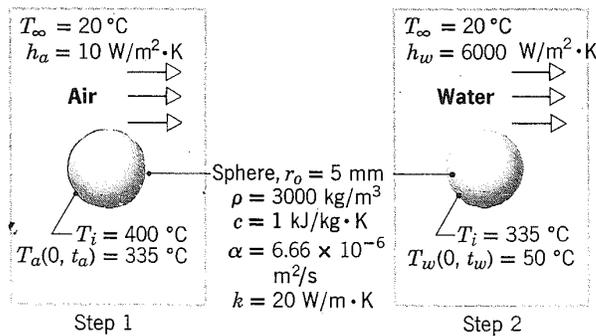

Assum

1. On
2. Co

Analys

1. To Bi

Ac
ter
5.1

w)

2. T u a;

a
e
t
t

Assumptions:

1. One-dimensional conduction in r .
2. Constant properties.

Analysis:

1. To determine whether the lumped capacitance method can be used, the Biot number is calculated. From Equation 5.10, with $L_c = r_o/3$,

$$Bi = \frac{h_a r_o}{3k} = \frac{10 \text{ W/m}^2 \cdot \text{K} \times 0.005 \text{ m}}{3 \times 20 \text{ W/m} \cdot \text{K}} = 8.33 \times 10^{-4}$$

Accordingly, the lumped capacitance method may be used, and the temperature is nearly uniform throughout the sphere. From Equation 5.5 it follows that

$$t_a = \frac{\rho V c}{h_a A_s} \ln \frac{\theta_i}{\theta_a} = \frac{\rho r_o c}{3h_a} \ln \frac{T_i - T_\infty}{T_a - T_\infty}$$

where $V = (4/3)\pi r_o^3$ and $A_s = 4\pi r_o^2$. Hence

$$t_a = \frac{3000 \text{ kg/m}^3 \times 0.005 \text{ m} \times 1000 \text{ J/kg} \cdot \text{K}}{3 \times 10 \text{ W/m}^2 \cdot \text{K}} \ln \frac{400 - 20}{335 - 20} = 94 \text{ s}$$

◁

2. To determine whether the lumped capacitance method may also be used for the second step of the cooling process, the Biot number is again calculated. In this case

$$Bi = \frac{h_w r_o}{3k} = \frac{6000 \text{ W/m}^2 \cdot \text{K} \times 0.005 \text{ m}}{3 \times 20 \text{ W/m} \cdot \text{K}} = 0.50$$

and the lumped capacitance method is not appropriate. However, to an excellent approximation, the temperature of the sphere is uniform at $t = t_a$ and the Heisler charts may be used for the calculations from $t = t_a$ to $t = t_a + t_w$. Using Figure 5.14 with

$$Bi^{-1} = \frac{k}{h_w r_o} = \frac{20 \text{ W/m} \cdot \text{K}}{6000 \text{ W/m}^2 \cdot \text{K} \times 0.005 \text{ m}} = 0.67$$

$$\frac{\theta_o}{\theta_i} = \frac{T_o - T_\infty}{T_i - T_\infty} = \frac{50 - 20}{335 - 20} = 0.095$$

the center
is situation,

ond step is

vective heat

'm³, $k = 20$

rocess to be

or the center
ation of step

it follows that $Fo \approx 0.80$, and

$$t_w = Fo \frac{r_o^2}{\alpha} \approx 0.80 \frac{(0.005 \text{ m})^2}{6.66 \times 10^{-6} \text{ m}^2/\text{s}} \approx 3.0 \text{ s} \quad \triangleleft$$

Comments:

1. If the temperature distribution in the sphere at the conclusion of step 1 were not uniform, the Heisler chart could not be used for the calculations of step 2.
2. The surface temperature of the sphere at the conclusion of step 2 may be obtained from Figure 5.15. With

$$Bi^{-1} = 0.67 \quad \text{and} \quad \frac{r}{r_o} = 1$$

$$\frac{\theta(r_o)}{\theta_o} = \frac{T(r_o) - T_\infty}{T_o - T_\infty} \approx 0.52$$

Hence

$$T(r_o) \approx 20^\circ\text{C} + 0.52(50 - 20)^\circ\text{C} \approx 36^\circ\text{C}$$

The variation of the center and surface temperature with time is then as follows.

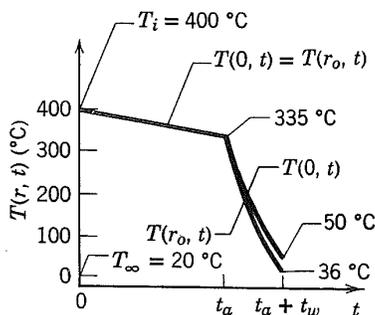

3. For the step 2 transient process in water, the one-term approximation is appropriate for determining the time t_w at which the center temperature reaches 50°C , that is, $T(0, t_w) = 50^\circ\text{C}$. Rearranging Equation 5.50c,

$$Fo = -\frac{1}{\zeta_1^2} \ln \left[\frac{\theta_o^*}{C_1} \right] = -\frac{1}{\zeta_1^2} \ln \left[\frac{1}{C_1} \times \frac{T(0, t_w) - T_\infty}{T_i - T_\infty} \right]$$

Using Table 5.1 to obtain the coefficients for $Bi = 1/0.67 = 1.50$ ($C_1 = 1.376$ and $\zeta_1 = 1.800$ rad) and substituting appropriate tempera-

tur
Su
of

5.7 THE

Another semi-infinite medium is changing its conduction idealization response during are un T by Eq interior

T_s
T_s
T_i

Figure 5.15

tures, it follows that

$$Fo = - \frac{1}{(1.800 \text{ rad})^2} \ln \left[\frac{1}{1.376} \times \frac{(50 - 20)^\circ\text{C}}{(335 - 20)^\circ\text{C}} \right] = 0.82$$

Substituting for r_o and α , it follows that $t_w = 3.1$ s, which is within 3% of the value of 3.0 s obtained from the Heisler chart.

5.7 THE SEMI-INFINITE SOLID

Another simple geometry for which analytical solutions may be obtained is the *semi-infinite solid*. Since such a solid extends to infinity in all but one direction, it is characterized by a single identifiable surface (Figure 5.17). If a sudden change of conditions is imposed at this surface, transient, one-dimensional conduction will occur within the solid. The semi-infinite solid provides a *useful idealization* for many practical problems. It may be used to determine transient heat transfer near the surface of the earth or to approximate the transient response of a finite solid, such as a thick slab. For this second situation the approximation would be reasonable for the early portion of the transient, during which temperatures in the slab interior (well removed from the surface) are uninfluenced by the change in surface conditions.

The heat equation for transient conduction in a semi-infinite solid is given by Equation 5.26. The initial condition is prescribed by Equation 5.27, and the interior boundary condition is of the form

$$T(\infty, t) = T_i \tag{5.53}$$

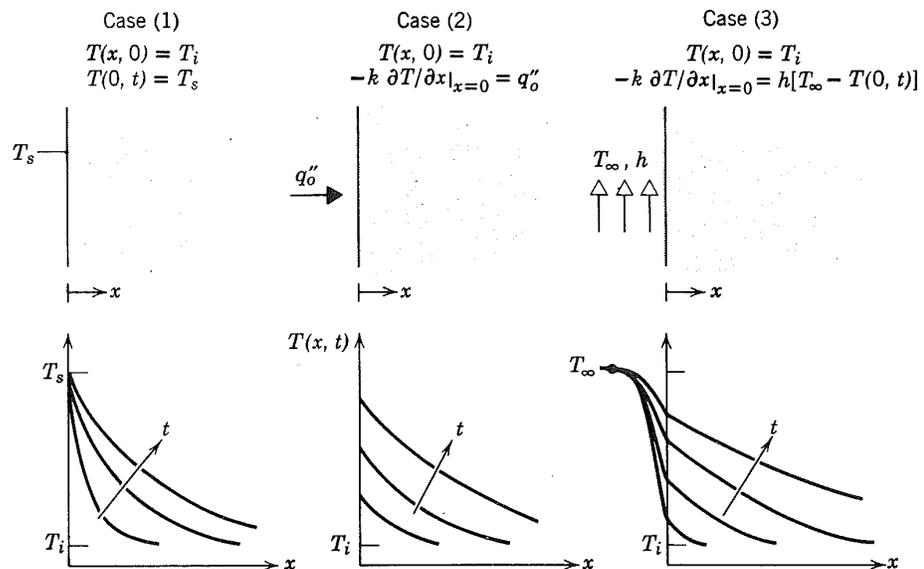

Figure 5.17 Transient temperature distributions in a semi-infinite solid for three surface conditions: constant surface temperature, constant surface heat flux, and surface convection.

on of step 1
the calcula-

step 2 may

ie is then as

roximation is
er tempera-
g Equation

0.67 = 1.50
te tempera-

Closed-form solutions have been obtained for three important surface conditions, instantaneously applied at $t = 0$ [1, 2]. These conditions are shown in Figure 5.17. They include application of a constant surface temperature $T_s \neq T_i$, application of a constant surface heat flux q''_o , and exposure of the surface to a fluid characterized by $T_\infty \neq T_i$ and the convection coefficient h . The solutions are summarized as follows.

Case 1 Constant Surface Temperature

$$T(0, t) = T_s \tag{5.54}$$

$$\frac{T(x, t) - T_s}{T_i - T_s} = \text{erf}\left(\frac{x}{2\sqrt{\alpha t}}\right) \tag{5.55}$$

$$q''_s(t) = -k \frac{\partial T}{\partial x} \Big|_{x=0} = \frac{k(T_s - T_i)}{\sqrt{\pi \alpha t}} \tag{5.56}$$

Case 2 Constant Surface Heat Flux

$$q''_s = q''_o \tag{5.57}$$

$$T(x, t) - T_i = \frac{2q''_o(\alpha t/\pi)^{1/2}}{k} \exp\left(\frac{-x^2}{4\alpha t}\right) - \frac{q''_o x}{k} \text{erfc}\left(\frac{x}{2\sqrt{\alpha t}}\right) \tag{5.58}$$

Case 3 Surface Convection

$$-k \frac{\partial T}{\partial x} \Big|_{x=0} = h[T_\infty - T(0, t)] \tag{5.59}$$

$$\frac{T(x, t) - T_i}{T_\infty - T_i} = \text{erfc}\left(\frac{x}{2\sqrt{\alpha t}}\right) - \left[\exp\left(\frac{hx}{k} + \frac{h^2 \alpha t}{k^2}\right) \right] \left[\text{erfc}\left(\frac{x}{2\sqrt{\alpha t}} + \frac{h\sqrt{\alpha t}}{k}\right) \right] \tag{5.60}$$

The quantity $\text{erf } w$ appearing in Equation 5.55 is the *Gaussian error function*, which is tabulated in Section B.1 of Appendix B. The *complementary error function*, $\text{erfc } w$, is defined as

$$\text{erfc } w \equiv 1 - \text{erf } w$$

Temperature histories for the three cases are also shown in Figure 5.17. Carefully note their distinguishing features. For case 3 the specific temperature histories computed from Equation 5.60 are plotted in Figure 5.18. Note that the curve corresponding to $h = \infty$ is equivalent to the result that would be obtained for a sudden change in the *surface temperature* to $T_s = T_\infty$. That is, for $h = \infty$ the second term on the right-hand side of Equation 5.60 goes to zero, and the result is equivalent to Equation 5.55.

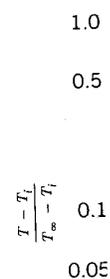

Figure 5.17 : solid wall with convection



Figure 5.18 : semi-infinite wall with convection

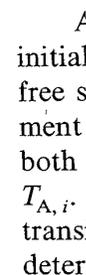

Figure 5.19 : from

Subs

surface conditions are shown in Figure 5.17. Note that the temperature profile at the surface would be T_∞ . That is, Equation 5.60 goes to

$$(5.54)$$

$$(5.55)$$

$$(5.56)$$

$$(5.57)$$

$$(5.58)$$

$$(5.59)$$

$$(5.60)$$

error function, elementary error

Figure 5.17. temperature profile. Note that it would be T_∞ . That is, Equation 5.60 goes to

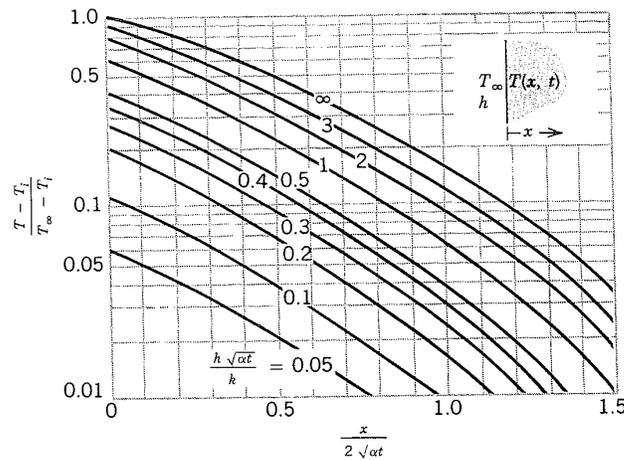

Figure 5.18 Temperature histories in a semi-infinite solid with surface convection [2]. Adapted with permission.

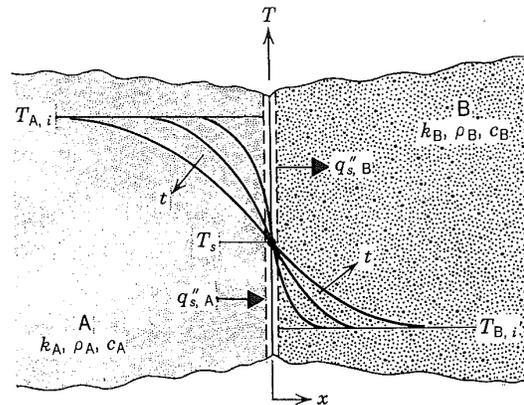

Figure 5.19 Interfacial contact between two semi-infinite solids at different initial temperatures.

An interesting permutation of case 1 results when two semi-infinite solids, initially at uniform temperatures $T_{A,i}$ and $T_{B,i}$, are placed in contact at their free surfaces (Figure 5.19). If the contact resistance is negligible, the requirement of thermal equilibrium dictates that, at the instant of contact ($t = 0$), both surfaces must assume the same temperature T_s , for which $T_{B,i} < T_s < T_{A,i}$. Since T_s does not change with increasing time, it follows that the transient thermal response and the surface heat flux of each of the solids is determined by Equations 5.55 and 5.56, respectively.

The equilibrium surface temperature of Figure 5.19 may be determined from a surface energy balance, which requires that

$$q''_{s,A} = q''_{s,B} \tag{5.61}$$

Substituting from Equation 5.56 for $q''_{s,A}$ and $q''_{s,B}$ and recognizing that the x

coordinate of Figure 5.19 requires a sign change for $q''_{s,A}$, it follows that

$$\frac{-k_A(T_s - T_{A,i})}{(\pi\alpha_A t)^{1/2}} = \frac{k_B(T_s - T_{B,i})}{(\pi\alpha_B t)^{1/2}} \quad (5.62)$$

or, solving for T_s ,

$$T_s = \frac{(k\rho c)_A^{1/2}T_{A,i} + (k\rho c)_B^{1/2}T_{B,i}}{(k\rho c)_A^{1/2} + (k\rho c)_B^{1/2}} \quad (5.63)$$

Hence, the quantity $m \equiv (k\rho c)^{1/2}$ is a weighting factor which determines whether T_s will more closely approach $T_{A,i}$ ($m_A > m_B$) or $T_{B,i}$ ($m_B > m_A$).

EXAMPLE 5.4

In laying water mains, utilities must be concerned with the possibility of freezing during cold periods. Although the problem of determining the temperature in soil as a function of time is complicated by changing surface conditions, reasonable estimates can be based on the assumption of a constant surface temperature over a prolonged period of cold weather. What minimum burial depth x_m would you recommend to avoid freezing under conditions for which soil, initially at a uniform temperature of 20°C, is subjected to a constant surface temperature of -15°C for 60 days?

SOLUTION

Known: Temperature imposed at the surface of soil that is initially at 20°C.

Find: The depth x_m to which the soil has frozen after 60 days.

Schematic:

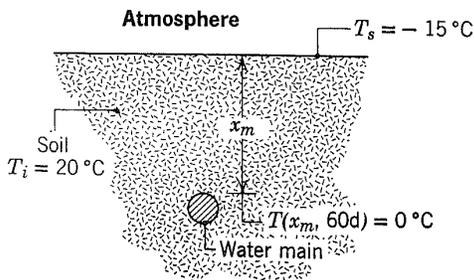

Assumptions:

1. One-dimensional conduction in x .
2. Soil is a semi-infinite medium.
3. Constant properties.

Property
 $c = 184$

Analysis
Figure
by Equ
ture ch

T

or

$\frac{C}{2}$

Hence

$\frac{1}{2}$

and

x

Com
natur

5.8 MU

Trans
three
can b
(
a un
lengt
cond
temp

the h

ws that

$$(5.62)$$

$$(5.63)$$

1 determines
 $m_B > m_A$).

possibility of
 ing the tem-
 ging surface
 of a constant
 at minimum
 onditions for
 bjected to a

nitially at

Properties: Table A.3, soil (300 K): $\rho = 2050 \text{ kg/m}^3$, $k = 0.52 \text{ W/m} \cdot \text{K}$,
 $c = 1840 \text{ J/kg} \cdot \text{K}$, $\alpha = (k/\rho c) = 0.138 \times 10^{-6} \text{ m}^2/\text{s}$.

Analysis: The prescribed conditions correspond to those of case 1 of Figure 5.17, and the transient temperature response of the soil is governed by Equation 5.55. Hence at the time $t = 60$ days after the surface temperature change,

$$\frac{T(x_m, t) - T_s}{T_i - T_s} = \text{erf}\left(\frac{x_m}{2\sqrt{\alpha t}}\right)$$

or

$$\frac{0 - (-15)}{20 - (-15)} = 0.429 = \text{erf}\left(\frac{x_m}{2\sqrt{\alpha t}}\right)$$

Hence from Appendix B.1

$$\frac{x_m}{2\sqrt{\alpha t}} = 0.40$$

and

$$x_m = 0.80\sqrt{\alpha t} = 0.80(0.138 \times 10^{-6} \text{ m}^2/\text{s} \times 60 \text{ days} \times 24 \text{ h/day} \\ \times 3600 \text{ s/h})^{1/2} = 0.68 \text{ m} \quad \triangleleft$$

Comments: The properties of soil are highly variable, depending on the nature of the soil and its moisture content.

5.8 MULTIDIMENSIONAL EFFECTS

Transient problems are frequently encountered for which two- and even three-dimensional effects are significant. Solution to a class of such problems can be obtained from the one-dimensional results of Sections 5.6 and 5.7.

Consider immersing the *short* cylinder of Figure 5.20, which is initially at a uniform temperature T_i , in a fluid of temperature $T_\infty \neq T_i$. Because the length and diameter are comparable, the subsequent transfer of energy by conduction will be significant for both the r and x coordinate directions. The temperature within the cylinder will therefore depend on r , x , and t .

Assuming constant properties and no generation, the appropriate form of the heat equation is, from Equation 2.20,

$$\frac{1}{r} \frac{\partial}{\partial r} \left(r \frac{\partial T}{\partial r} \right) + \frac{\partial^2 T}{\partial x^2} = \frac{1}{\alpha} \frac{\partial T}{\partial t}$$

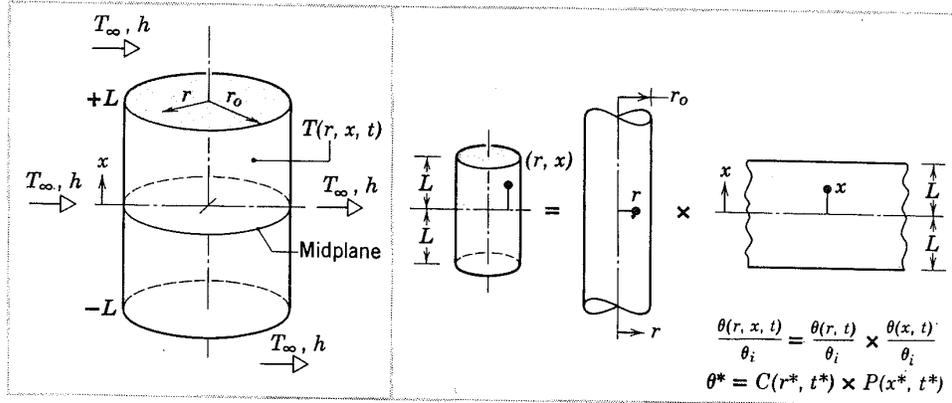

Figure 5.20 Two-dimensional, transient conduction in a short cylinder. (a) Geometry. (b) Form of the product solution.

where x has been used in place of z to designate the axial coordinate. A closed-form solution to this equation may be obtained by the separation of variables method. Although we will not consider the details of this solution, it is important to note that the end result may be expressed in the following form.

$$\frac{T(r, x, t) - T_\infty}{T_i - T_\infty} = \left. \frac{T(x, t) - T_\infty}{T_i - T_\infty} \right|_{\text{Plane wall}} \cdot \left. \frac{T(r, t) - T_\infty}{T_i - T_\infty} \right|_{\text{Infinite cylinder}} \quad (d)$$

That is, the two-dimensional solution may be expressed as a *product* of one-dimensional solutions that correspond to those for a plane wall of thickness $2L$ and an infinite cylinder of radius r_o . These solutions are available from Figures 5.8 and 5.9 for the plane wall and Figures 5.11 and 5.12 for the infinite cylinder. They are also available from the one-term approximations given by Equations 5.40 and 5.49.

Results for other multidimensional geometries are summarized in Figure 5.21. In each case the multidimensional solution is prescribed in terms of a product involving one or more of the following one-dimensional solutions.

$$S(x, t) \equiv \left. \frac{T(x, t) - T_\infty}{T_i - T_\infty} \right|_{\text{Semi-infinite solid}} \quad (5.64)$$

$$P(x, t) \equiv \left. \frac{T(x, t) - T_\infty}{T_i - T_\infty} \right|_{\text{Plane wall}} \quad (5.65)$$

$$C(r, t) \equiv \left. \frac{T(r, t) - T_\infty}{T_i - T_\infty} \right|_{\text{Infinite cylinder}} \quad (5.66)$$

The x coordinate for the semi-infinite solid is measured from the surface,

(a)

(d)

$S(x_3,$

(g)

Figure
prod

whe
5.21
dim
5.21
plar

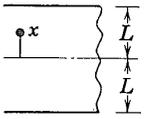

$$\frac{\theta(r, t)}{\theta_i} \times \frac{\theta(x, t)}{\theta_i} \times \frac{\theta(z, t)}{\theta_i} = \frac{\theta(r^*, t^*)}{\theta_i} \times \frac{\theta(x^*, t^*)}{\theta_i} \times \frac{\theta(z^*, t^*)}{\theta_i}$$

a) Geometry.

coordinate. A separation of variables solution, in the following

ite
der

product of solutions available in 5.12 for the approximations

ed in Figure 5.21 in terms of a product of solutions.

$$(5.64)$$

$$(5.65)$$

$$(5.66)$$

the surface,

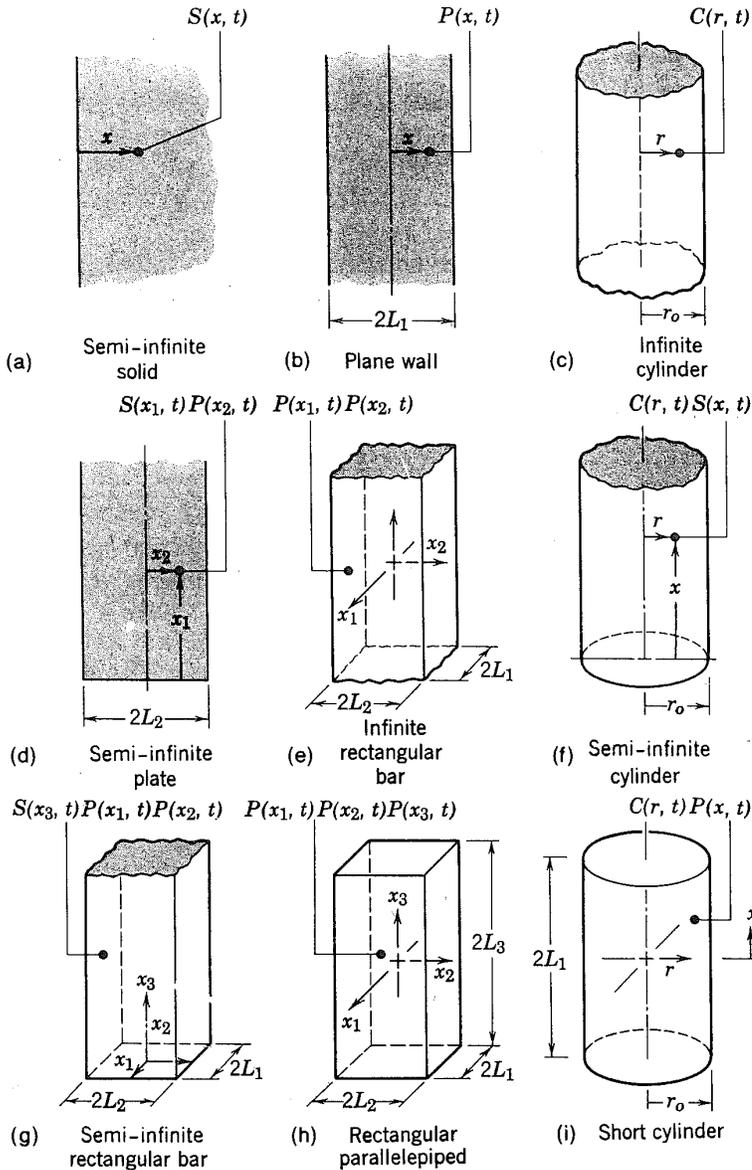

Figure 5.21 Solutions for multidimensional systems expressed as products of one-dimensional results.

whereas for the plane wall it is measured from the midplane. In using Figure 5.21 the coordinate origins should be carefully noted. The transient, three-dimensional temperature distribution in a rectangular parallelepiped, Figure 5.21h, is then, for example, the product of three one-dimensional solutions for plane walls of thicknesses $2L_1$, $2L_2$, and $2L_3$. That is,

$$\frac{T(x_1, x_2, x_3, t) - T_\infty}{T_i - T_\infty} = P(x_1, t) \cdot P(x_2, t) \cdot P(x_3, t)$$

The distances x_1 , x_2 , and x_3 are all measured with respect to a rectangular coordinate system whose origin is at the center of the parallelepiped.

The amount of energy Q transferred to or from a solid during a multidimensional transient conduction process may also be determined by combining one-dimensional results, as shown by Langston [7].

EXAMPLE 5.5

In a manufacturing process stainless steel cylinders (AISI 304) initially at 600 K are quenched by submersion in an oil bath maintained at 300 K with $h = 500 \text{ W/m}^2 \cdot \text{K}$. Each cylinder is of length $2L = 60 \text{ mm}$ and diameter $D = 80 \text{ mm}$. Consider a time 3 min into the cooling process and determine temperatures at the center of the cylinder, at the center of a circular face, and at the midheight of the side.

SOLUTION

Known: Initial temperature and dimensions of cylinder and temperature and convection conditions of an oil bath.

Find: Temperatures $T(r, x, t)$ after 3 min at the cylinder center, $T(0, 0, 3 \text{ min})$, at the center of a circular face, $T(0, L, 3 \text{ min})$, and at the midheight of the side, $T(r_o, 0, 3 \text{ min})$.

Schematic:

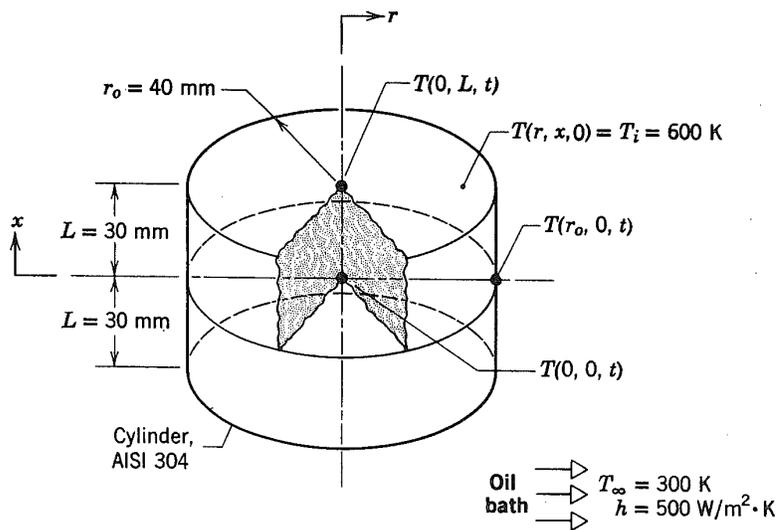

Assum

1. T
2. C

Prope
450 K
 $k/\rho c$

Analy
the te
follow

where
tively

$T(0,$

Henc

it fo

Simi

rectangular
ed.
g a multidi-
y combining

) initially at
. 300 K with
nd diameter
d determine
lar face, and

perature

r, $T(0, 0,$
midheight

Assumptions:

1. Two-dimensional conduction in r and x .
2. Constant properties.

Properties: Table A.1, stainless steel, AISI 304 [$T = (600 + 300)/2 = 450$ K]: $\rho = 7900$ kg/m³, $c = 526$ J/kg · K, $k = 17.4$ W/m · K, $\alpha = k/\rho c = 4.19 \times 10^{-6}$ m²/s.

Analysis: The solid steel cylinder corresponds to case i of Figure 5.21, and the temperature at any point in the cylinder may be expressed as the following product of one-dimensional solutions.

$$\frac{T(r, x, t) - T_\infty}{T_i - T_\infty} = P(x, t)C(r, t)$$

where $P(x, t)$ and $C(r, t)$ are defined by Equations 5.65 and 5.66, respectively. Accordingly, for the center of the cylinder,

$$\frac{T(0, 0, 3 \text{ min}) - T_\infty}{T_i - T_\infty} = \frac{T(0, 3 \text{ min}) - T_\infty}{T_i - T_\infty} \Big|_{\text{Plane wall}} \cdot \frac{T(0, 3 \text{ min}) - T_\infty}{T_i - T_\infty} \Big|_{\text{Infinite cylinder}}$$

Hence, for the plane wall, with

$$Bi^{-1} = \frac{k}{hL} = \frac{17.4 \text{ W/m} \cdot \text{K}}{500 \text{ W/m}^2 \cdot \text{K} \times 0.03 \text{ m}} = 1.16$$

$$Fo = \frac{\alpha t}{L^2} = \frac{4.19 \times 10^{-6} \text{ m}^2/\text{s} \times 180 \text{ s}}{(0.03 \text{ m})^2} = 0.84$$

it follows from Figure 5.8 that

$$\frac{\theta_o}{\theta_i} = \frac{T(0, 3 \text{ min}) - T_\infty}{T_i - T_\infty} \Big|_{\text{Plane wall}} \approx 0.64$$

Similarly, for the infinite cylinder, with

$$Bi^{-1} = \frac{k}{hr_o} = \frac{17.4 \text{ W/m} \cdot \text{K}}{500 \text{ W/m}^2 \cdot \text{K} \times 0.04 \text{ m}} = 0.87$$

$$Fo = \frac{\alpha t}{r_o^2} = \frac{4.19 \times 10^{-6} \text{ m}^2/\text{s} \times 180 \text{ s}}{(0.04 \text{ m})^2} = 0.47$$

it follows from Figure 5.11 that

$$\frac{\theta_o}{\theta_i} = \frac{T(0, 3 \text{ min}) - T_\infty}{T_i - T_\infty} \Bigg|_{\text{Infinite cylinder}} \approx 0.55$$

Hence, for the center of the cylinder,

$$\frac{T(0, 0, 3 \text{ min}) - T_\infty}{T_i - T_\infty} \approx 0.64 \times 0.55 \approx 0.35$$

$$T(0, 0, 3 \text{ min}) \approx 300 \text{ K} + 0.35(600 - 300) \text{ K} \approx 405 \text{ K} \quad \triangleleft$$

The temperature at the center of a circular face may be obtained from the requirement that

$$\frac{T(0, L, 3 \text{ min}) - T_\infty}{T_i - T_\infty} = \frac{T(L, 3 \text{ min}) - T_\infty}{T_i - T_\infty} \Bigg|_{\text{Plane wall}} \cdot \frac{T(0, 3 \text{ min}) - T_\infty}{T_i - T_\infty} \Bigg|_{\text{Infinite cylinder}}$$

where, from Figure 5.9 with $(x/L) = 1$ and $Bi^{-1} = 1.16$,

$$\frac{\theta(L)}{\theta_o} = \frac{T(L, 3 \text{ min}) - T_\infty}{T(0, 3 \text{ min}) - T_\infty} \Bigg|_{\text{Plane wall}} \approx 0.68$$

Hence

$$\frac{T(L, 3 \text{ min}) - T_\infty}{T_i - T_\infty} \Bigg|_{\text{Plane wall}} = \frac{T(L, 3 \text{ min}) - T_\infty}{T(0, 3 \text{ min}) - T_\infty} \Bigg|_{\text{Plane wall}} \cdot \frac{T(0, 3 \text{ min}) - T_\infty}{T_i - T_\infty} \Bigg|_{\text{Plane wall}}$$

$$\frac{T(L, 3 \text{ min}) - T_\infty}{T_i - T_\infty} \Bigg|_{\text{Plane wall}} \approx 0.68 \times 0.64 \approx 0.44$$

Hence

$$\frac{T(0, L, 3 \text{ min}) - T_\infty}{T_i - T_\infty} \approx 0.44 \times 0.55 \approx 0.24$$

$$T(0, L, 3 \text{ min}) \approx 300 \text{ K} + 0.24(600 - 300) \text{ K} \approx 372 \text{ K} \quad \triangleleft$$

The temperature at the midheight of the side may be obtained from the requirement that

$$\frac{T(r_o, 0, 3 \text{ min}) - T_\infty}{T_i - T_\infty} = \frac{T(0, 3 \text{ min}) - T_\infty}{T_i - T_\infty} \Bigg|_{\text{Plane wall}} \cdot \frac{T(r_o, 3 \text{ min}) - T_\infty}{T_i - T_\infty} \Bigg|_{\text{Infinite cylinder}}$$

where, f

$$\frac{\theta(r)}{\theta}$$

Hence

$$\frac{T($$

$$\frac{T($$

Hence

$$\frac{T$$

Comm

1. Ve
3 1
2. Th
les
mi

w/
W

where, from Figure 5.12 with $(r/r_o) = 1$ and $Bi^{-1} = 0.87$,

$$\frac{\theta(r_o)}{\theta_o} = \frac{T(r_o, 3 \text{ min}) - T_\infty}{T(0, 3 \text{ min}) - T_\infty} \Big|_{\text{Infinite cylinder}} \approx 0.61$$

Hence

$$\frac{T(r_o, 3 \text{ min}) - T_\infty}{T_i - T_\infty} \Big|_{\text{Infinite cylinder}} = \frac{T(r_o, 3 \text{ min}) - T_\infty}{T(0, 3 \text{ min}) - T_\infty} \Big|_{\text{Infinite cylinder}} \cdot \frac{T(0, 3 \text{ min}) - T_\infty}{T_i - T_\infty} \Big|_{\text{Infinite cylinder}}$$

$$\frac{T(r_o, 3 \text{ min}) - T_\infty}{T_i - T_\infty} \Big|_{\text{Infinite cylinder}} \approx 0.61 \times 0.55 \approx 0.34$$

Hence

$$\frac{T(r_o, 0, 3 \text{ min}) - T_\infty}{T_i - T_\infty} \approx 0.64 \times 0.34 \approx 0.22$$

$$T(r_o, 0, 3 \text{ min}) \approx 300 \text{ K} + 0.22(600 - 300) \text{ K} \approx 366 \text{ K} \quad \triangleleft$$

Comments:

1. Verify that the temperature at the edge of the cylinder is $T(r_o, L, 3 \text{ min}) \approx 345 \text{ K}$.
2. The one-term approximations can be used to calculate the dimensionless temperatures read from the Heisler charts. For the *plane wall*, the midplane temperature can be determined from Equation 5.41

$$\theta_o^* = \frac{\theta_o}{\theta_i} = C_1 \exp(-\zeta_1^2 Fo)$$

where, with $Bi = 0.862$, $C_1 = 1.109$ and $\zeta_1 = 0.814 \text{ rad}$ from Table 5.1. With $Fo = 0.84$,

$$\frac{\theta_o}{\theta_i} \Big|_{\text{Plane wall}} = 1.109 \exp[-(0.814 \text{ rad})^2 \times 0.84] = 0.636$$

1 from the

$$\frac{T_\infty}{\theta_o} \Big|_{\text{Infinite cylinder}}$$

$$\frac{-T_\infty}{\theta_o} \Big|_{\text{Plane wall}}$$

1 from the

$$\frac{T_\infty}{\theta_o} \Big|_{\text{Infinite cylinder}}$$

The surface temperature can be evaluated using Equation 5.40b

$$\frac{\theta^*}{\theta_o^*} = \frac{\theta}{\theta_o} = \cos(\zeta_1 x^*)$$

with $x^* = 1$ to give

$$\frac{\theta^*(1, Fo)}{\theta_o^*} = \frac{\theta(L, t)}{\theta_o} = \cos(0.814 \text{ rad} \times 1) = 0.687$$

For the *infinite cylinder*, the centerline temperature can be determined from Equation 5.49c.

$$\theta_o^* = \frac{\theta_o}{\theta_i} = C_1 \exp(-\zeta_1^2 Fo)$$

where, with $Bi = 1.15$, $C_1 = 1.227$ and $\zeta_1 = 1.307$ from Table 5.1. With $Fo = 0.47$,

$$\left. \frac{\theta_o}{\theta_i} \right|_{\text{Infinite cylinder}} = 1.109 \exp[-(1.307 \text{ rad})^2 \times 0.47] = 0.550$$

The surface temperature can be evaluated using Equation 5.49b

$$\frac{\theta^*}{\theta_o^*} = \frac{\theta}{\theta_o} = J_0(\zeta_1 r^*)$$

with $r^* = 1$ and the value of the Bessel function determined from Table B.4,

$$\frac{\theta^*(1, Fo)}{\theta_o^*} = \frac{\theta(L, t)}{\theta_o} = J_0(1.307 \text{ rad} \times 1) = 0.616$$

The one-term approximations are in good agreement with results from the Heisler charts.

5.9 FINITE-DIFFERENCE METHODS

Analytical solutions to transient problems are restricted to simple geometries and boundary conditions, such as those considered in the preceding sections. Extensive coverage of these and other solutions is treated in the literature [1–4]. However, in many cases the geometry and/or boundary conditions preclude the use of analytical techniques, and recourse must be made to

finite-difference
state conditions
considered
conduction
may be

5.9.1 Discretization

Once a discretized
approximation

$$\frac{1}{\alpha}$$

To obtain
differences
4.31 at
the x
discretization
introduced

t

and this
is expressed

Δ

The series
derived
with
performance
finite-difference
in space
I
finite-difference
temperatures
derived
at
forwards
the r
Equation

finite-difference methods. Such methods, introduced in Section 4.4 for steady-state conditions, are readily extended to transient problems. In this section we consider *explicit* and *implicit* forms of finite-difference solutions to transient conduction problems. More detailed treatments, as well as related algorithms, may be found in the literature [8–10].

5.9.1 Discretization of the Heat Equation: The Explicit Method

Once again consider the two-dimensional system of Figure 4.5. Under transient conditions with constant properties and no internal generation, the appropriate form of the heat equation, Equation 2.15, is

$$\frac{1}{\alpha} \frac{\partial T}{\partial t} = \frac{\partial^2 T}{\partial x^2} + \frac{\partial^2 T}{\partial y^2} \quad (5.67)$$

To obtain the finite-difference form of this equation, we may use the *central-difference* approximations to the spatial derivatives prescribed by Equations 4.31 and 4.32. Once again the m and n subscripts may be used to designate the x and y locations of *discrete nodal points*. However, in addition to being discretized in space, the problem must be discretized in time. The integer p is introduced for this purpose, where

$$t = p \Delta t \quad (5.68)$$

and the finite-difference approximation to the time derivative in Equation 5.67 is expressed as

$$\left. \frac{\partial T}{\partial t} \right|_{m,n} \approx \frac{T_{m,n}^{p+1} - T_{m,n}^p}{\Delta t} \quad (5.69)$$

The superscript p is used to denote the time dependence of T , and the time derivative is expressed in terms of the difference in temperatures associated with the *new* ($p + 1$) and *previous* (p) times. Hence calculations must be performed at successive times separated by the interval Δt , and just as a finite-difference solution restricts temperature determination to discrete points in space, it also restricts it to discrete points in time.

If Equation 5.69 is substituted into Equation 5.67, the nature of the finite-difference solution will depend on the specific time at which temperatures are evaluated in the finite-difference approximations to the spatial derivatives. In the *explicit method* of solution, these temperatures are evaluated at the *previous* (p) time. Hence Equation 5.69 is considered to be a *forward-difference* approximation to the time derivative. Evaluating terms on the right-hand side of Equations 4.31 and 4.32 at p and substituting into Equation 5.67, the explicit form of the finite-difference equation for the

0b

etermined

5.1. With

9b

ned from

sults from

e geometries
ing sections.
he literature
y conditions
be made to

interior node m, n is

$$\frac{1}{\alpha} \frac{T_{m,n}^{p+1} - T_{m,n}^p}{\Delta t} = \frac{T_{m+1,n}^p + T_{m-1,n}^p - 2T_{m,n}^p}{(\Delta x)^2} + \frac{T_{m,n+1}^p + T_{m,n-1}^p - 2T_{m,n}^p}{(\Delta y)^2} \quad (5.70)$$

Solving for the nodal temperature at the new $(p + 1)$ time and assuming that $\Delta x = \Delta y$, it follows that

$$T_{m,n}^{p+1} = Fo(T_{m+1,n}^p + T_{m-1,n}^p + T_{m,n+1}^p + T_{m,n-1}^p) + (1 - 4Fo)T_{m,n}^p \quad (5.71)$$

where Fo is a finite-difference form of the Fourier number

$$Fo = \frac{\alpha \Delta t}{(\Delta x)^2} \quad (5.72)$$

If the system is one-dimensional in x , the explicit form of the finite-difference equation for an interior node m reduces to

$$T_m^{p+1} = Fo(T_{m+1}^p + T_{m-1}^p) + (1 - 2Fo)T_m^p \quad (5.73)$$

Equations 5.71 and 5.73 are *explicit* because *unknown* nodal temperatures for the new time are determined exclusively by *known* nodal temperatures at the previous time. Hence calculation of the unknown temperatures is straightforward. Since the temperature of each interior node is known at $t = 0$ ($p = 0$) from prescribed initial conditions, the calculations begin at $t = \Delta t$ ($p = 1$), where Equation 5.71 or 5.73 is applied to each interior node to determine its temperature. With temperatures known for $t = \Delta t$, the appropriate finite-difference equation is then applied at each node to determine its temperature at $t = 2 \Delta t$ ($p = 2$). In this way, the transient temperature distribution is obtained by *marching out in time*, using intervals of Δt .

The accuracy of the finite-difference solution may be improved by decreasing the values of Δx and Δt . Of course, the number of interior nodal points that must be considered increases with decreasing Δx , and the number of time intervals required to carry the solution to a prescribed final time increases with decreasing Δt . Hence, the computation time increases with decreasing Δx and Δt . The choice of Δx is typically based on a compromise between accuracy and computational requirements. Once this selection has been made, however, the value of Δt may not be chosen independently. It is, instead, determined by *stability* requirements.

An ally *sta* should. However, numeric tions m steady- value o and otl *criteria* thermo this tex with th general of the involv; determ the des interior

Fo

and fo

Fo

For pr upper

En balanc Accou energy

\dot{E}

In the all hea

T the or mine thickn transf 5.76 t

h

An undesirable feature of the explicit method is that it is not unconditionally *stable*. In a transient problem, the solution for the nodal temperatures should continuously approach final (steady-state) values with increasing time. However, with the explicit method, this solution may be characterized by numerically induced oscillations, which are physically impossible. The oscillations may become *unstable*, causing the solution to diverge from the actual steady-state conditions. To prevent such erroneous results, the prescribed value of Δt must be maintained below a certain limit, which depends on Δx and other parameters of the system. This dependence is termed a *stability criterion*, which may be obtained mathematically [8] or demonstrated from a thermodynamic argument (see Problem 5.69). For the problems of interest in this text, *the criterion is determined by requiring that the coefficient associated with the node of interest at the previous time is greater than or equal to zero*. In general, this is done by collecting all terms involving $T_{m,n}^p$ to obtain the form of the coefficient. This result is then used to obtain a limiting relation involving Fo , from which the maximum allowable value of Δt may be determined. For example, with Equations 5.71 and 5.73 already expressed in the desired form, it follows that the stability criterion for a one-dimensional interior node is $(1 - 2Fo) \geq 0$, or

(5.70)

assuming that

(5.71)

(5.72)

$$Fo \leq \frac{1}{2} \tag{5.74}$$

finite-difference

and for a two-dimensional node, it is $(1 - 4Fo) \geq 0$, or

(5.73)

$$Fo \leq \frac{1}{4} \tag{5.75}$$

For prescribed values of Δx and α , these criteria may be used to determine upper limits to the value of Δt .

Equations 5.71 and 5.73 may also be derived by applying the energy balance method of Section 4.4.3 to a control volume about the interior node. Accounting for changes in thermal energy storage, a general form of the energy balance equation may be expressed as

$$\dot{E}_{in} + \dot{E}_g = \dot{E}_{st} \tag{5.76}$$

In the interest of adopting a consistent methodology, it is again assumed that all heat flow is *into* the node.

To illustrate application of Equation 5.76, consider the surface node of the one-dimensional system shown in Figure 5.22. To more accurately determine thermal conditions near the surface, this node has been assigned a thickness which is one-half that of the interior nodes. Assuming convection transfer from an adjoining fluid and no generation, it follows from Equation 5.76 that

$$hA(T_\infty - T_0^p) + \frac{kA}{\Delta x}(T_1^p - T_0^p) = \rho cA \frac{\Delta x}{2} \frac{T_0^{p+1} - T_0^p}{\Delta t}$$

temperatures
 peratures at
 s is straight-
 vn at $t = 0$
 n at $t = \Delta t$
 or node to
 re appropriate
 etermine its
 temperature
 f Δt .
 oved by de-
 terior nodal
 the number
 l final time
 reases with
 compromise
 election has
 dently. It is,

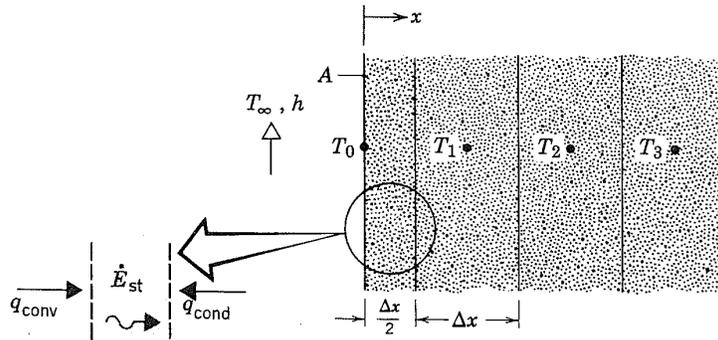

Figure 5.22 Surface node with convection and one-dimensional transient conduction.

or, solving for the surface temperature at $t + \Delta t$,

$$T_0^{p+1} = \frac{2h \Delta t}{\rho c \Delta x} (T_\infty - T_0^p) + \frac{2\alpha \Delta t}{\Delta x^2} (T_1^p - T_0^p) + T_0^p$$

Recognizing that $(2h \Delta t / \rho c \Delta x) = 2(h \Delta x / k)(\alpha \Delta t / \Delta x^2) = 2BiFo$ and grouping terms involving T_0^p , it follows that

$$T_0^{p+1} = 2Fo(T_1^p + BiT_\infty) + (1 - 2Fo - 2BiFo)T_0^p \tag{5.77}$$

The finite-difference form of the Biot number is

$$Bi = \frac{h \Delta x}{k} \tag{5.78}$$

Recalling the procedure for determining the stability criterion, we require that the coefficient for T_0^p be greater than or equal to zero. Hence

$$1 - 2Fo - 2BiFo \geq 0$$

or

$$Fo(1 + Bi) \leq \frac{1}{2} \tag{5.79}$$

Since the complete finite-difference solution requires the use of Equation 5.73 for the interior nodes, as well as Equation 5.77 for the surface node, Equation 5.79 must be contrasted with Equation 5.74 to determine which requirement is the more stringent. Since $Bi \geq 0$, it is apparent that the limiting value of Fo for Equation 5.79 is less than that for Equation 5.74. To ensure stability for all nodes, Equation 5.79 should therefore be used to select the maximum allowable value of Fo , and hence Δt , to be used in the calculations.

Forms of the explicit finite-difference equation for several common geometries are presented in Table 5.2. Each equation may be derived by applying the energy balance method to a control volume about the corresponding node. To develop confidence in your ability to apply this method, you should attempt to verify at least one of these equations.

Table 5.2 Summary of transient, two-dimensional finite-difference equations ($\Delta x = \Delta y$)

$$2BiFo \text{ and} \tag{5.77}$$

$$\tag{5.78}$$

we require

$$\tag{5.79}$$

Equation 5.73, Equation 5.74, and Equation 5.75 are the stability requirements for the implicit method. The stability requirement is more restrictive than for the explicit method.

Commonly, the stability requirement is derived by setting the amplification factor equal to one. This method is the most common.

Table 5.2 Summary of transient, two-dimensional finite-difference equations ($\Delta x = \Delta y$)

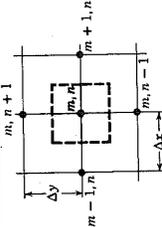
CONFIGURATION	FINITE-DIFFERENCE EQUATION	STABILITY CRITERION	EXPLICIT METHOD	IMPLICIT METHOD
	$T_{m,n}^{p+1} = Fo(T_{m+1,n}^p + T_{m-1,n}^p + T_{m,n+1}^p + T_{m,n-1}^p) + (1 - 4Fo)T_{m,n}^p$	$Fo \leq \frac{1}{4}$	$T_{m,n}^{p+1} = Fo(T_{m+1,n}^p + T_{m-1,n}^p + T_{m,n+1}^p + T_{m,n-1}^p) + (1 - 4Fo)T_{m,n}^p$	$(1 + 4Fo)T_{m,n}^{p+1} - Fo(T_{m+1,n}^{p+1} + T_{m-1,n}^{p+1} + T_{m,n+1}^{p+1} + T_{m,n-1}^{p+1}) = T_{m,n}^p$
<p>1. Interior node</p>	$T_{m,n}^{p+1} = \frac{2}{3}Fo(T_{m+1,n}^p + T_{m-1,n}^p + 2T_{m,n+1}^p + 2T_{m,n-1}^p) + 2BiT_{\infty}^p + (1 - 4Fo - \frac{4}{3}BiFo)T_{m,n}^p$	$Fo(3 + Bi) \leq \frac{3}{4}$	$T_{m,n}^{p+1} = \frac{2}{3}Fo(T_{m+1,n}^p + T_{m-1,n}^p + 2T_{m,n+1}^p + 2T_{m,n-1}^p) + 2BiT_{\infty}^p + (1 - 4Fo - \frac{4}{3}BiFo)T_{m,n}^p$	$(1 + 4Fo(1 + \frac{1}{3}Bi))T_{m,n}^{p+1} - \frac{2}{3}Fo(T_{m+1,n}^{p+1} + T_{m-1,n}^{p+1} + 2T_{m,n+1}^{p+1} + 2T_{m,n-1}^{p+1}) - 2BiT_{\infty}^{p+1} = T_{m,n}^p$
<p>2. Node at interior corner with convection</p>	$T_{m,n}^{p+1} = Fo(2T_{m-1,n}^p + T_{m,n+1}^p + T_{m,n-1}^p + 2BiT_{\infty}^p) + (1 - 4Fo - \frac{4}{3}BiFo)T_{m,n}^p$	$Fo(2 + Bi) \leq \frac{1}{2}$	$T_{m,n}^{p+1} = Fo(2T_{m-1,n}^p + T_{m,n+1}^p + T_{m,n-1}^p + 2BiT_{\infty}^p) + (1 - 4Fo - \frac{4}{3}BiFo)T_{m,n}^p$	$(1 + 2Fo(2 + Bi))T_{m,n}^{p+1} - Fo(2T_{m-1,n}^{p+1} + T_{m,n+1}^{p+1} + T_{m,n-1}^{p+1}) - 2BiT_{\infty}^{p+1} = T_{m,n}^p$
<p>3. Node at plane surface with convection^a</p>	$T_{m,n}^{p+1} = 2Fo(T_{m-1,n}^p + T_{m,n+1}^p + T_{m,n-1}^p + 2BiT_{\infty}^p) + (1 - 4Fo - 4BiFo)T_{m,n}^p$	$Fo(1 + Bi) \leq \frac{1}{4}$	$T_{m,n}^{p+1} = 2Fo(T_{m-1,n}^p + T_{m,n+1}^p + T_{m,n-1}^p + 2BiT_{\infty}^p) + (1 - 4Fo - 4BiFo)T_{m,n}^p$	$(1 + 4Fo(1 + Bi))T_{m,n}^{p+1} - 2Fo(T_{m-1,n}^{p+1} + T_{m,n+1}^{p+1} + T_{m,n-1}^{p+1}) - 4BiFoT_{\infty}^{p+1} = T_{m,n}^p$
<p>4. Node at exterior corner with convection</p>	$T_{m,n}^{p+1} = Fo(2T_{m-1,n}^p + T_{m,n+1}^p + T_{m,n-1}^p + 2BiT_{\infty}^p) + (1 - 4Fo - \frac{4}{3}BiFo)T_{m,n}^p$	$Fo(2 + Bi) \leq \frac{1}{2}$	$T_{m,n}^{p+1} = Fo(2T_{m-1,n}^p + T_{m,n+1}^p + T_{m,n-1}^p + 2BiT_{\infty}^p) + (1 - 4Fo - \frac{4}{3}BiFo)T_{m,n}^p$	$(1 + 2Fo(2 + Bi))T_{m,n}^{p+1} - Fo(2T_{m-1,n}^{p+1} + T_{m,n+1}^{p+1} + T_{m,n-1}^{p+1}) - 2BiT_{\infty}^{p+1} = T_{m,n}^p$

^aTo obtain the finite-difference equation and/or stability criterion for an adiabatic surface (or surface of symmetry), simply set Bi equal to zero.

EXAMPLE 5.6

A fuel element of a nuclear reactor is in the shape of a plane wall of thickness $2L = 20 \text{ mm}$ and is convectively cooled at both surfaces, with $h = 1100 \text{ W/m}^2 \cdot \text{K}$ and $T_\infty = 250^\circ\text{C}$. At normal operating power, heat is generated uniformly within the element at a volumetric rate of $\dot{q}_1 = 10^7 \text{ W/m}^3$. A departure from the steady-state conditions associated with normal operation will occur if there is a change in the generation rate. Consider a sudden change to $\dot{q}_2 = 2 \times 10^7 \text{ W/m}^3$, and use the explicit finite-difference method to determine the fuel element temperature distribution after 1.5 s. The fuel element thermal properties are $k = 30 \text{ W/m} \cdot \text{K}$ and $\alpha = 5 \times 10^{-6} \text{ m}^2/\text{s}$.

SOLUTION

Known: Conditions associated with heat generation in a rectangular fuel element with surface cooling.

Find: Temperature distribution 1.5 s after a change in operating power.

Schematic:

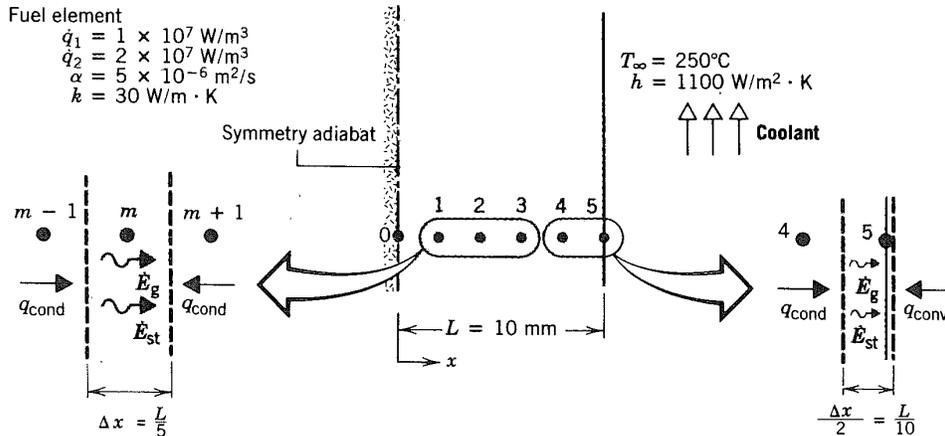

Assumptions:

1. One-dimensional conduction in x .
2. Uniform generation.
3. Constant properties.

Analysis: A numerical solution will be obtained using a space increment of $\Delta x = 2 \text{ mm}$. Since there is symmetry about the midplane, the nodal network yields six unknown nodal temperatures. Using the energy balance

method,
for any i

$$kA \frac{T_i - T_{i-1}}{\Delta x} - \dot{q}_i \Delta x + kA \frac{T_{i+1} - T_i}{\Delta x} = \rho \Delta x c_p \frac{dT_i}{dt}$$

Solving

$$T_m^{p+1} = \frac{k}{\rho \Delta x c_p} \left(\frac{T_{m-1}^p + T_{m+1}^p}{\Delta x} - \dot{q}_m \right) + T_m^p$$

This equation is used to solve for the temperature at nodes 1 through 5 at time $t + \Delta t$.

$$hA(T_\infty - T_0) = kA \frac{T_0 - T_1}{\Delta x}$$

or

$$T_0^{p+1} = \frac{k}{h \Delta x} (T_1^p - T_0^p) + T_0^p$$

Similarly,

for node 5,

$$T_5^{p+1} = \frac{k}{h \Delta x} (T_4^p - T_5^p) + T_5^p$$

Hence,

$$T_0^{p+1} = \frac{k}{h \Delta x} (T_1^p - T_0^p) + T_0^p$$

it follows that

$$T_0^{p+1} = \frac{k}{h \Delta x} (T_1^p - T_0^p) + T_0^p$$

or

$$\Delta T_0 = \frac{k}{h \Delta x} (T_1^p - T_0^p)$$

To be sponsored

method, Equation 5.76, an explicit finite-difference equation may be derived for any interior node m .

$$kA \frac{T_{m-1}^p - T_m^p}{\Delta x} + kA \frac{T_{m+1}^p - T_m^p}{\Delta x} + \dot{q}A \Delta x = \rho A \Delta x c \frac{T_m^{p+1} - T_m^p}{\Delta t}$$

Solving for T_m^{p+1} and rearranging,

$$T_m^{p+1} = Fo \left[T_{m-1}^p + T_{m+1}^p + \frac{\dot{q}(\Delta x)^2}{k} \right] + (1 - 2Fo)T_m^p \quad (1)$$

This equation may be used for node 0, with $T_{m-1}^p = T_{m+1}^p$, as well as for nodes 1, 2, 3, and 4. Applying energy conservation to a control volume about node 5,

$$hA(T_\infty - T_5^p) + kA \frac{T_4^p - T_5^p}{\Delta x} + \dot{q}A \frac{\Delta x}{2} = \rho A \frac{\Delta x}{2} c \frac{T_5^{p+1} - T_5^p}{\Delta t}$$

or

$$T_5^{p+1} = 2Fo \left[T_4^p + BiT_\infty + \frac{\dot{q}(\Delta x)^2}{2k} \right] + (1 - 2Fo - 2BiFo)T_5^p \quad (2)$$

Since the most restrictive stability criterion is associated with Equation 2, we select Fo from the requirement that

$$Fo(1 + Bi) \leq \frac{1}{2}$$

Hence, with

$$Bi = \frac{h \Delta x}{k} = \frac{1100 \text{ W/m}^2 \cdot \text{K} (0.002 \text{ m})}{30 \text{ W/m} \cdot \text{K}} = 0.0733$$

it follows that

$$Fo \leq 0.466$$

or

$$\Delta t = \frac{Fo(\Delta x)^2}{\alpha} \leq \frac{0.466(2 \times 10^{-3} \text{ m})^2}{5 \times 10^{-6} \text{ m}^2/\text{s}} \leq 0.373 \text{ s}$$

To be well within the stability limit, we select $\Delta t = 0.3 \text{ s}$, which corresponds to

$$Fo = \frac{5 \times 10^{-6} \text{ m}^2/\text{s}(0.3 \text{ s})}{(2 \times 10^{-3} \text{ m})^2} = 0.375$$

l of thickness
ith $h = 1100$
is generated
)⁷ W/m³. A
nal operation
dden change
e method to
s. The fuel
0⁻⁶ m²/s.

gular fuel

g power.

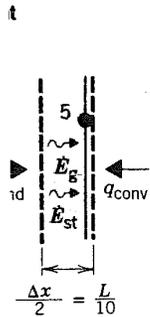

ement of
he nodal
y balance

Substituting numerical values, including $\dot{q} = \dot{q}_2 = 2 \times 10^7 \text{ W/m}^3$, the nodal equations become

$$T_0^{p+1} = 0.375(2T_1^p + 2.67) + 0.250T_0^p$$

$$T_1^{p+1} = 0.375(T_0^p + T_2^p + 2.67) + 0.250T_1^p$$

$$T_2^{p+1} = 0.375(T_1^p + T_3^p + 2.67) + 0.250T_2^p$$

$$T_3^{p+1} = 0.375(T_2^p + T_4^p + 2.67) + 0.250T_3^p$$

$$T_4^{p+1} = 0.375(T_3^p + T_5^p + 2.67) + 0.250T_4^p$$

$$T_5^{p+1} = 0.750(T_4^p + 19.67) + 0.195T_5^p$$

To begin the marching solution, the initial temperature distribution must be known. This distribution is given by Equation 3.42, with $\dot{q} = \dot{q}_1$. Obtaining $T_s = T_5$ from Equation 3.46,

$$T_5 = T_\infty + \frac{\dot{q}L}{h} = 250^\circ\text{C} + \frac{10^7 \text{ W/m}^3 \times 0.01 \text{ m}}{1100 \text{ W/m}^2 \cdot \text{K}} = 340.91^\circ\text{C}$$

it follows that

$$T(x) = 16.67 \left(1 - \frac{x^2}{L^2} \right) + 340.91^\circ\text{C}$$

Computed temperatures for the nodal points of interest are shown in the first row of the accompanying table.

Using the finite-difference equations, the nodal temperatures may be sequentially calculated with a time increment of 0.3 s until the desired final time is reached. The results are illustrated in rows 2 through 6 of the table and may be contrasted with the new steady-state condition (row 7), which was obtained by using Equations 3.42 and 3.46 with $\dot{q} = \dot{q}_2$.

Tabulated nodal temperatures

p	t (s)	T_0	T_1	T_2	T_3	T_4	T_5
0	0	357.58	356.91	354.91	351.58	346.91	340.91
1	0.3	358.08	357.41	355.41	352.08	347.41	341.41
2	0.6	358.58	357.91	355.91	352.58	347.91	341.88
3	0.9	359.08	358.41	356.41	353.08	348.41	342.35
4	1.2	359.58	358.91	356.91	353.58	348.89	342.82
5	1.5	360.08	359.41	357.41	354.07	349.37	343.27
∞	∞	465.15	463.82	459.82	453.15	443.82	431.82

Comments:
transient made to allow the integration until the

5.9.2 Discussion

In the case of a semi-infinite body, the temperature at the surface at time t is limited by the interval of time in which the implicit method is used. The results are shown in Figure 5.69. The derivative of the temperature is the derivative of the equation.

Rear

nod

Comments: It is evident that at 1.5 s, the wall is in the early stages of the transient process and that many additional calculations would have to be made to reach steady-state conditions with the finite-difference solution. The computation time could be slightly reduced by using the maximum allowable time increment ($\Delta t = 0.373$ s), but with some loss of accuracy. In the interest of maximizing accuracy, the time interval should be reduced until the computed results become independent of further reductions in Δt .

5.9.2 Discretization of the Heat Equation: The Implicit Method

In the *explicit* finite-difference scheme, the temperature of any node at $t + \Delta t$ may be calculated from knowledge of temperatures at the same and neighboring nodes for the *preceding time* t . Hence, determination of a nodal temperature at some time is *independent* of temperatures at other nodes for the *same time*. Although the method offers computational convenience, it suffers from limitations on the selection of Δt . For a given space increment, the time interval must be compatible with stability requirements. Frequently, this dictates the use of extremely small values of Δt , and a very large number of time intervals may be necessary to obtain a solution.

A reduction in the amount of computation time may often be realized by employing an *implicit*, rather than explicit, finite-difference scheme. The implicit form of a finite-difference equation may be derived by using Equation 5.69 to approximate the time derivative, while evaluating all other temperatures at the *new* ($p + 1$) time, instead of the previous (p) time. Equation 5.69 is then considered to provide a *backward-difference* approximation to the time derivative. In contrast to Equation 5.70, the implicit form of the finite-difference equation for the interior node of a two-dimensional system is then

$$\frac{1}{\alpha} \frac{T_{m,n}^{p+1} - T_{m,n}^p}{\Delta t} = \frac{T_{m+1,n}^{p+1} + T_{m-1,n}^{p+1} - 2T_{m,n}^{p+1}}{(\Delta x)^2} + \frac{T_{m,n+1}^{p+1} + T_{m,n-1}^{p+1} - 2T_{m,n}^{p+1}}{(\Delta y)^2} \quad (5.86)$$

Rearranging and assuming $\Delta x = \Delta y$, it follows that

$$(1 + 4Fo)T_{m,n}^{p+1} - Fo(T_{m+1,n}^{p+1} + T_{m-1,n}^{p+1} + T_{m,n+1}^{p+1} + T_{m,n-1}^{p+1}) = T_{m,n}^p \quad (5.87)$$

From Equation 5.87 it is evident that the *new* temperature of the m, n node depends on the *new* temperatures of its adjoining nodes, which are, in

the nodal

tribution
h $\dot{q} = \dot{q}_1$.

vn in the
s may be
ired final
the table
7), which

general, unknown. Hence, to determine the unknown nodal temperatures at $t + \Delta t$, the corresponding nodal equations must be *solved simultaneously*. Such a solution may be effected by using Gauss–Seidel iteration or matrix inversion, as discussed in Section 4.5. The *marching solution* would then involve simultaneously solving the nodal equations at each time $t = \Delta t, 2\Delta t, \dots$, until the desired final time was reached.

Although computations involving the implicit method are more complicated than those of the explicit method, the implicit formulation has the important advantage of being *unconditionally stable*. That is, the solution remains stable for all space and time intervals, in which case there are no restrictions on Δx and Δt . Since larger values of Δt may therefore be used with an implicit method, computation times may often be reduced, with little loss of accuracy. Nevertheless, to maximize accuracy, Δt should be sufficiently small to ensure that the results are independent of further reductions in its value.

The implicit form of a finite-difference equation may also be derived from the energy balance method. For the surface node of Figure 5.22, it is readily shown that

$$(1 + 2Fo + 2FoBi)T_0^{p+1} - 2FoT_1^{p+1} = 2FoBiT_\infty + T_0^p \quad (5.88)$$

For any interior node of Figure 5.22, it may also be shown that

$$(1 + 2Fo)T_m^{p+1} - Fo(T_{m-1}^{p+1} + T_{m+1}^{p+1}) = T_m^p \quad (5.89)$$

Forms of the implicit finite-difference equation for other common geometries are presented in Table 5.2. Each equation may be derived by applying the energy balance method.

EXAMPLE 5.7

A thick slab of copper initially at a uniform temperature of 20°C is suddenly exposed to radiation at one surface such that the net heat flux is maintained at a constant value of $3 \times 10^5 \text{ W/m}^2$. Using the explicit and implicit finite-difference techniques with a space increment of $\Delta x = 75 \text{ mm}$, determine the temperature at the irradiated surface and at an interior point that is 150 mm from the surface after 2 min have elapsed. Compare the results with those obtained from an appropriate analytical solution.

SOLUTION

Known: Thick slab of copper, initially at a uniform temperature, is subjected to a constant net heat flux at one surface.

Find:

1. Use the minimum
2. Required
3. Determined

Schema

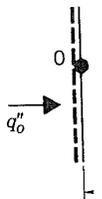

Assumptions

1. One-dimensional
2. Thermophysical properties constant
3. Convection

Properties:
 10^{-6} m^2

Analysis:

1. Analytical

or

Time

temperatures at
neously. Such
rix inversion,
olve simulta-
..., until the

more compli-
tion has the
the solution
there are no
fore be used
d, with little
e sufficiently
ctions in its

derived from
it is readily

(5.88)

(5.89)

1 geometries
plying the

is suddenly
aintained at
ollicit finite-
termine the
is 150 mm
with those

, is sub-

Find:

- Using the explicit finite-difference method, determine temperatures at the surface and 150 mm from the surface after an elapsed time of 2 min.
- Repeat the calculations using the implicit finite-difference method.
- Determine the same temperatures analytically.

Schematic:

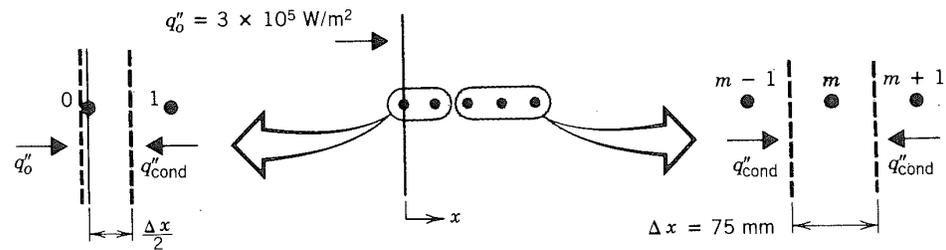

Assumptions:

- One-dimensional conduction in x .
- Thick slab may be approximated as a semi-infinite medium with constant surface heat flux.
- Constant properties.

Properties: Table A.1, copper (300 K): $k = 401 \text{ W/m} \cdot \text{K}$, $\alpha = 117 \times 10^{-6} \text{ m}^2/\text{s}$.

Analysis:

- An explicit form of the finite-difference equation for the surface node may be obtained by applying an energy balance to a control volume about the node.

$$q_o'' A + kA \frac{T_1^p - T_0^p}{\Delta x} = \rho A \frac{\Delta x}{2} c \frac{T_0^{p+1} - T_0^p}{\Delta t}$$

or

$$T_0^{p+1} = 2Fo \left(\frac{q_o'' \Delta x}{k} + T_1^p \right) + (1 - 2Fo) T_0^p$$

The finite-difference equation for any interior node is given by Equation 5.73. Both the surface and interior nodes are governed by the

stability criterion

$$Fo \leq \frac{1}{2}$$

Noting that the finite-difference equations are simplified by choosing the maximum allowable value of Fo , we select $Fo = \frac{1}{2}$. Hence

$$\Delta t = Fo \frac{(\Delta x)^2}{\alpha} = \frac{1}{2} \frac{(0.075 \text{ m})^2}{117 \times 10^{-6} \text{ m}^2/\text{s}} = 24 \text{ s}$$

With

$$\frac{q''_o \Delta x}{k} = \frac{3 \times 10^5 \text{ W/m}^2 (0.075 \text{ m})}{401 \text{ W/m} \cdot \text{K}} = 56.1^\circ\text{C}$$

the finite-difference equations become

$$T_0^{p+1} = 56.1^\circ\text{C} + T_1^p \quad \text{and} \quad T_m^{p+1} = \frac{T_{m+1}^p + T_{m-1}^p}{2}$$

for the surface and interior nodes, respectively. Performing the calculations, the results are tabulated as follows.

Explicit finite-difference solution for $Fo = \frac{1}{2}$

p	t (s)	T_0	T_1	T_2	T_3	T_4
0	0	20	20	20	20	20
1	24	76.1	20	20	20	20
2	48	76.1	48.1	20	20	20
3	72	104.2	48.1	34.1	20	20
4	96	104.2	69.1	34.1	27.1	20
5	120	125.3	69.1	48.1	27.1	20

After 2 min, the surface temperature and the desired interior temperature are $T_0 = 125.3^\circ\text{C}$ and $T_2 = 48.1^\circ\text{C}$.

Note that calculation of identical temperatures at successive times for the same node is an idiosyncrasy of using the maximum allowable value of Fo with the explicit finite-difference technique. The actual physical condition is, of course, one in which the temperature changes continuously with time. The idiosyncrasy is eliminated and the accuracy of the calculations is improved by reducing the value of Fo .

To determine the extent to which the accuracy may be improved by reducing Fo , let us redo the calculations for $Fo = \frac{1}{4}$ ($\Delta t = 12 \text{ s}$). The

finit

and

Expl

p

0

1

2

3

4

5

6

7

8

9

10

Af

44.

is

rec

tra

me

ex:

2.

Pe

nc

or

A

finite-difference equations are then of the form

$$T_0^{p+1} = \frac{1}{2}(56.1^\circ\text{C} + T_1^p) + \frac{1}{2}T_0^p$$

$$T_m^{p+1} = \frac{1}{4}(T_{m+1}^p + T_{m-1}^p) + \frac{1}{2}T_m^p$$

and the results of the calculations are tabulated as follows.

Explicit finite-difference solution for $Fo = 1/4$

p	t (s)	T_0	T_1	T_2	T_3	T_4	T_5	T_6	T_7	T_8
0	0	20	20	20	20	20	20	20	20	20
1	12	48.1	20	20	20	20	20	20	20	20
2	24	62.1	27.0	20	20	20	20	20	20	20
3	36	72.6	34.0	21.8	20	20	20	20	20	20
4	48	81.4	40.6	24.4	20.4	20	20	20	20	20
5	60	89.0	46.7	27.5	21.3	20.1	20	20	20	20
6	72	95.9	52.5	30.7	22.6	20.4	20.0	20	20	20
7	84	102.3	57.9	34.1	24.1	20.8	20.1	20.0	20	20
8	96	108.1	63.1	37.6	25.8	21.5	20.3	20.0	20.0	20
9	108	113.7	68.0	41.0	27.6	22.2	20.5	20.1	20.0	20.0
10	120	118.9	72.6	44.4	29.6	23.2	20.8	20.2	20.0	20.0

After 2 min, the desired temperatures are $T_0 = 118.9^\circ\text{C}$ and $T_2 = 44.4^\circ\text{C}$. Comparing the above results with those obtained for $Fo = \frac{1}{2}$, it is clear that by reducing Fo we have eliminated the problem of recurring temperatures. We have also predicted greater thermal penetration (to node 6 instead of node 3). An assessment of the improvement in accuracy must await a comparison with results based on an exact solution.

- Performing an energy balance on a control volume about the surface node, the implicit form of the finite-difference equation is

$$q_o'' + k \frac{T_1^{p+1} - T_0^{p+1}}{\Delta x} = \rho \frac{\Delta x}{2} c \frac{T_0^{p+1} - T_0^p}{\Delta t}$$

or,

$$(1 + 2Fo)T_0^{p+1} - 2FoT_1^{p+1} = \frac{2\alpha q_o'' \Delta t}{k \Delta x} + T_0^p$$

Arbitrarily choosing $Fo = \frac{1}{2}$ ($\Delta t = 24$ s), it follows that

$$2T_0^{p+1} - T_1^{p+1} = 56.1 + T_0^p$$

by choos-
ence

e calcula-

tempera-

sive times
allowable
he actual
e changes
the accu-
 Fo .
improved
12 s). The

From Equation 5.89, the finite-difference equation for any interior node is then of the form

$$-T_{m-1}^{p+1} + 4T_m^{p+1} - T_{m+1}^{p+1} = 2T_m^p$$

Since we are dealing with a semi-infinite solid, the number of nodes is, in principle, infinite. In practice, however, the number may be limited to the nodes that are affected by the change in the boundary condition for the time period of interest. From the results of the explicit method, it is evident that we are safe in choosing nine nodes corresponding to T_0, T_1, \dots, T_8 . We are thereby assuming that, at $t = 120$ s, there has been no change in T_8 .

We now have a set of nine equations that must be solved simultaneously for each time increment. Using the matrix inversion method, we express the equations in the form $[A][T] = [C]$, where

$$[A] = \begin{bmatrix} 2 & -1 & 0 & 0 & 0 & 0 & 0 & 0 & 0 \\ -1 & 4 & -1 & 0 & 0 & 0 & 0 & 0 & 0 \\ 0 & -1 & 4 & -1 & 0 & 0 & 0 & 0 & 0 \\ 0 & 0 & -1 & 4 & -1 & 0 & 0 & 0 & 0 \\ 0 & 0 & 0 & -1 & 4 & -1 & 0 & 0 & 0 \\ 0 & 0 & 0 & 0 & -1 & 4 & -1 & 0 & 0 \\ 0 & 0 & 0 & 0 & 0 & -1 & 4 & -1 & 0 \\ 0 & 0 & 0 & 0 & 0 & 0 & -1 & 4 & -1 \\ 0 & 0 & 0 & 0 & 0 & 0 & 0 & -1 & 4 \end{bmatrix}$$

$$[C] = \begin{bmatrix} 56.1 + T_0^p \\ 2T_1^p \\ 2T_2^p \\ 2T_3^p \\ 2T_4^p \\ 2T_5^p \\ 2T_6^p \\ 2T_7^p \\ 2T_8^p + T_9^{p+1} \end{bmatrix}$$

Note that numerical values for the components of $[C]$ are determined from previous values of the nodal temperatures. Note also how the finite-difference equation for node 8 appears in matrices $[A]$ and $[C]$.

A table of nodal temperatures may be compiled, beginning with the first row ($p = 0$) corresponding to the prescribed initial condition. To obtain nodal temperatures for subsequent times, the inverse of the

coe
the
obt
ing

th
re
Th

Implic

p t

0

1

2

3

4

5

3. A

t

$T(0, 12$

rior node

umber of
er may be
boundary
he explicit
des corre-
t = 120 s,

d simulta-
1 method,

$$\begin{bmatrix} 0 \\ 0 \\ 0 \\ 0 \\ 0 \\ 0 \\ 0 \\ 0 \\ 0 \\ -1 \\ 4 \end{bmatrix}$$

etermined
how the
and [C].
ning with
condition.
rse of the

coefficient matrix $[A]^{-1}$ must first be found. At each time $p + 1$, it is then multiplied by the column vector $[C]$, which is evaluated at p , to obtain the temperatures $T_0^{p+1}, T_1^{p+1}, \dots, T_8^{p+1}$. For example, multiplying $[A]^{-1}$ by the column vector corresponding to $p = 0$,

$$[C]_{p=0} = \begin{bmatrix} 76.1 \\ 40 \\ 40 \\ 40 \\ 40 \\ 40 \\ 40 \\ 40 \\ 60 \end{bmatrix}$$

the second row of the table is obtained. Updating $[C]$, the process is repeated four more times to determine the nodal temperatures at 120 s. The desired temperatures are $T_0 = 114.7^\circ\text{C}$ and $T_2 = 44.2^\circ\text{C}$.

Implicit finite-difference solution for $Fo = \frac{1}{2}$

p	t (s)	T_0	T_1	T_2	T_3	T_4	T_5	T_6	T_7	T_8
0	0	20.0	20.0	20.0	20.0	20.0	20.0	20.0	20.0	20.0
1	24	52.4	28.7	22.3	20.6	20.2	20.0	20.0	20.0	20.0
2	48	74.0	39.5	26.6	22.1	20.7	20.2	20.1	20.0	20.0
3	72	90.2	50.3	32.0	24.4	21.6	20.6	20.2	20.1	20.0
4	96	103.4	60.5	38.0	27.4	22.9	21.1	20.4	20.2	20.1
5	120	114.7	70.0	44.2	30.9	24.7	21.9	20.8	20.3	20.1

- Approximating the slab as a semi-infinite medium, the appropriate analytical expression is given by Equation 5.58, which may be applied to any point in the slab.

$$T(x, t) - T_i = \frac{2q_o''(at/\pi)^{1/2}}{k} \exp\left(-\frac{x^2}{4at}\right) - \frac{q_o''x}{k} \operatorname{erfc}\left(\frac{x}{2\sqrt{at}}\right)$$

At the surface, this expression yields

$$T(0, 120 \text{ s}) - 20^\circ\text{C} = \frac{2 \times 3 \times 10^5 \text{ W/m}^2}{401 \text{ W/m} \cdot \text{K}} (117 \times 10^{-6} \text{ m}^2/\text{s} \times 120 \text{ s}/\pi)^{1/2}$$

or

$$T(0, 120 \text{ s}) = 120.0^\circ\text{C}$$

◁

At the interior point ($x = 0.15$ m)

$$T(0.15 \text{ m}, 120 \text{ s}) - 20^\circ\text{C} = \frac{2 \times 3 \times 10^5 \text{ W/m}^2}{401 \text{ W/m} \cdot \text{K}} \times (117 \times 10^{-6} \text{ m}^2/\text{s} \times 120 \text{ s}/\pi)^{1/2} \times \exp \left[-\frac{(0.15 \text{ m})^2}{4 \times 117 \times 10^{-6} \text{ m}^2/\text{s} \times 120 \text{ s}} \right] - \frac{3 \times 10^5 \text{ W/m}^2 \times 0.15 \text{ m}}{401 \text{ W/m} \cdot \text{K}} \times \left[1 - \operatorname{erf} \left(\frac{0.15 \text{ m}}{2\sqrt{117 \times 10^{-6} \text{ m}^2/\text{s} \times 120 \text{ s}}} \right) \right] = 45.4^\circ\text{C} \quad \triangleleft$$

Comments:

1. Comparing the exact results with those obtained from the three approximate solutions, it is clear that the explicit method with $Fo = 1/4$ provides the most accurate predictions.

METHOD	$T_0 = T(0, 120 \text{ s})$	$T_2 = T(0.15 \text{ m}, 120 \text{ s})$
Explicit ($Fo = \frac{1}{2}$)	125.3	48.1
Explicit ($Fo = \frac{1}{4}$)	118.9	44.4
Implicit ($Fo = \frac{1}{2}$)	114.7	44.2
Exact	120.0	45.4

This is not unexpected, since the corresponding value of Δt is 50% smaller than that used in the other two methods.

2. Although computations are simplified by using the maximum allowable value of Fo in the explicit method, the accuracy of the results is seldom satisfactory.
3. Note that the coefficient matrix $[A]$ is *tridiagonal*. That is, all elements are zero except those which are on, or to either side of, the main diagonal. Tridiagonal matrices are associated with one-dimensional conduction problems. In such cases the problem of solving for the unknown temperatures is greatly simplified, and stock computer programs may readily be obtained for this purpose.
4. A more general radiative heating condition would be one in which the surface is suddenly exposed to large surroundings at an elevated temperature T_{sur} (Problem 5.84). The net rate at which radiation is transferred to the surface may then be calculated from Equation 1.7. Allowing for convection heat transfer to the surface, application of conservation of energy to the surface node yields an explicit finite-

diff

$\epsilon\sigma$

Use
cate
line
def

Th
rac
ity
cal
wh

5.10 SUN

Transi
import
certain
transie
If this
metho
Howe
be cor
availa
infinite
when
form
finite-
used

REFERE

1. (
2. (
3. (
4. (

difference equation of the form

$$\varepsilon\sigma [T_{\text{sur}}^4 - (T_0^p)^4] + h(T_\infty - T_0^p) + k \frac{T_1^p - T_0^p}{\Delta x} = \rho \frac{\Delta x}{2} c \frac{T_0^{p+1} - T_0^p}{\Delta t}$$

Use of this finite-difference equation in a numerical solution is complicated by the fact that it is *nonlinear*. However, the equation may be *linearized* by introducing the radiation heat transfer coefficient h_r , defined by Equation 1.9, and the finite-difference equation is

$$h_r^p (T_{\text{sur}} - T_0^p) + h(T_\infty - T_0^p) + k \frac{T_1^p - T_0^p}{\Delta x} = \rho \frac{\Delta x}{2} c \frac{T_0^{p+1} - T_0^p}{\Delta t}$$

The solution may proceed in the usual manner, although the effect of a radiative Biot number ($Bi_r \equiv h_r \Delta x/k$) must be included in the stability criterion and the value of h_r must be updated at each step in the calculations. If the implicit method is used, h_r is calculated at $p + 1$, in which case an iterative calculation must be made at each time step.

5.10 SUMMARY

Transient conduction occurs in numerous engineering applications, and it is important to appreciate the different methods for dealing with it. There is certainly much to be said for simplicity, in which case, when confronted with a transient problem, the first thing you should do is calculate the Biot number. If this number is much less than unity, you may use the lumped capacitance method to obtain accurate results with minimal computational requirements. However, if the Biot number is not much less than unity, spatial effects must be considered, and some other method must be used. Analytical results are available in convenient graphical and equation form for the plane wall, the infinite cylinder, the sphere, and the semi-infinite solid. You should know when and how to use these results. If geometrical complexities and/or the form of the boundary conditions preclude their use, recourse must be made to finite-difference methods. With the digital computer, such methods may be used to solve any conduction problem, regardless of complexity.

REFERENCES

1. Carslaw, H. S., and J. C. Jaeger, *Conduction of Heat in Solids*, 2nd ed., Oxford University Press, London, 1959.
2. Schneider, P. J., *Conduction Heat Transfer*, Addison-Wesley, Reading, MA, 1955.
3. Arpaci, V. S., *Conduction Heat Transfer*, Addison-Wesley, Reading, MA, 1966.
4. Özisik, M. N., *Heat Conduction*, Wiley, New York, 1980.

15 m

△

approx-
o = 1/4

is 50%

allowable
s seldom

elements
he main
ensional
for the
iter pro-

which the
ted tem-
is transi-
ion 1.7.
ation of
it finite-

5. Heisler, M. P., "Temperature Charts for Induction and Constant Temperature Heating," *Trans. ASME*, **69**, 227-236, 1947.
6. Gröber, H., S. Erk, and U. Grigull, *Fundamentals of Heat Transfer*, McGraw-Hill, New York, 1961.
7. Langston, L. S., "Heat Transfer from Multidimensional Objects Using One-Dimensional Solutions for Heat Loss," *Int. J. Heat Mass Transfer*, **25**, 149-150, 1982.
8. Richtmyer, R. D., and K. W. Morton, *Difference Methods for Initial Value Problems*, Wiley-Interscience, New York, 1967.
9. Myers, G. E., *Analytical Methods in Conduction Heat Transfer*, McGraw-Hill, New York, 1971.
10. Adams, J. A., and D. F. Rogers, *Computer-Aided Heat Transfer Analysis*, McGraw-Hill, New York, 1973.

PROBLEMS

Qualitative Considerations

- 5.1 Consider a thin electrical heater attached to a plate and backed by insulation. Initially, the heater and plate are at the temperature of the ambient air, T_∞ . Suddenly, the power to the heater is switched on giving rise to a constant heat flux q_o'' (W/m^2) at the inner surface of the plate.

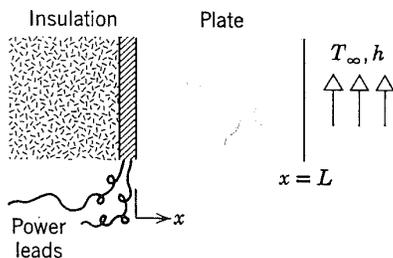

- (a) Sketch and label, on $T-x$ coordinates, the temperature distributions: initial, steady-state, and at two intermediate times.
 - (b) Sketch the heat flux at the outer surface $q_x''(L, t)$ as a function of time.
- 5.2 The inner surface of a plane wall is insulated while the outer surface is exposed to an airstream at T_∞ . The wall is at a uniform temperature corresponding to that of the airstream. Suddenly, a radiation heat source is switched on applying a uniform flux q_o'' to the outer surface.

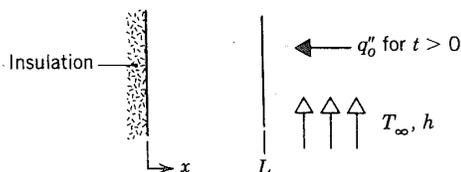

- (a) Sketch and label, on $T-x$ coordinates, the temperature distributions: initial, steady-state, and at two intermediate times.
- (b) Sketch the heat flux at the outer surface $q_x''(L, t)$ as a function of time.

5.3 A
fic
ur
he

m
si
e
B
ti
w
c
c

5.4 A
a
p
A
ti
(
(

(
(

Lumped C

5.5 S
c
V
k

5.6]
c
]
e
t
L
e

5.7 L
1
c
c
]
1

Temperature

McGraw-Hill,

Using One-
5, 149–150,

Initial Value

McGraw-Hill,

Error Analysis,

with insulation.
in ambient air, T_∞ .
constant heat flux

Conditions: initial,

at time t .The surface is exposed to
ambient air at temperature T_∞ .
The heat transfer coefficient is h .

Conditions: initial,

at time t .

- 5.3 A microwave oven operates on the principle that application of a high frequency field causes electrically polarized molecules in food to oscillate. The net effect is a *uniform generation* of thermal energy within the food, which enables it to be heated from refrigeration temperatures to 90°C in as short a time as 30 s.

Consider the process of cooking a slab of beef of thickness $2L$ in a microwave oven and compare it with cooking in a conventional oven, where *each side* of the slab is *heated by radiation* for a period of approximately 30 min. In each case the meat is to be heated from 0°C to a *minimum* temperature of 90°C . Base your comparison on a sketch of the temperature distribution at selected times for each of the cooking processes. In particular consider the time t_0 at which heating is initiated, a time t_1 during the heating process, the time t_2 corresponding to the conclusion of heating, and a time t_3 well into the subsequent cooling process.

- 5.4 A plate of thickness $2L$, surface area A_s , mass M , and specific heat c_p , initially at a uniform temperature T_i , is suddenly heated on both surfaces by a convection process (T_∞, h) for a period of time t_o , following which the plate is insulated. Assume that the midplane temperature does not reach T_∞ within this period of time.
- Assuming $Bi \gg 1$ for the heating process, sketch and label, on T - x coordinates, the following temperature distributions: initial, steady-state ($t \rightarrow \infty$), $T(x, t_o)$, and at two intermediate times between $t = t_o$ and $t \rightarrow \infty$.
 - Sketch and label, on T - t coordinates, the midplane and exposed surface temperature distributions.
 - Repeat parts a and b assuming $Bi \ll 1$ for the plate.
 - Derive an expression for the steady-state temperature $T(x, \infty) = T_f$, leaving your result in terms of plate parameters (M, c_p), thermal conditions (T_i, T_∞, h), the surface temperature $T(L, t)$, and the heating time t_o .

Lumped Capacitance Method

- 5.5 Steel balls 12 mm in diameter are annealed by heating to 1150 K and then slowly cooling to 400 K in an air environment for which $T_\infty = 325$ K and $h = 20$ $\text{W}/\text{m}^2 \cdot \text{K}$. Assuming the properties of the steel to be $k = 40$ $\text{W}/\text{m} \cdot \text{K}$, $\rho = 7800$ kg/m^3 , and $c = 600$ $\text{J}/\text{kg} \cdot \text{K}$, estimate the time required for the cooling process.
- 5.6 The heat transfer coefficient for air flowing over a sphere is to be determined by observing the temperature–time history of a sphere fabricated from pure copper. The sphere, which is 12.7 mm in diameter, is at 66°C before it is inserted into an airstream having a temperature of 27°C . A thermocouple on the outer surface of the sphere indicates 55°C 69 s after the sphere is inserted in the airstream. Assume, and then justify, that the sphere behaves as a spacewise isothermal object and calculate the heat transfer coefficient.
- 5.7 A solid steel sphere (AISI 1010), 300 mm in diameter, is coated with a dielectric material layer of thickness 2 mm and thermal conductivity 0.04 $\text{W}/\text{m} \cdot \text{K}$. The coated sphere is initially at a uniform temperature of 500°C and is suddenly quenched in a large oil bath for which $T_\infty = 100^\circ\text{C}$ and $h = 3300$ $\text{W}/\text{m}^2 \cdot \text{K}$. Estimate the time required for the coated sphere temperature to reach 140°C . *Hint:* Neglect the effect of energy storage in the dielectric material, since its thermal capacitance (ρcV) is small compared to that of the steel sphere.

- 5.8 A spherical lead bullet of 6 mm diameter is moving at a Mach number of approximately 3. The resulting shock wave heats the air around the bullet to 700 K, and the average convection coefficient for heat transfer between the air and the bullet is $500 \text{ W/m}^2 \cdot \text{K}$. If the bullet leaves the barrel at 300 K and the time of flight is 0.4 s, what is its surface temperature on impact?
- 5.9 Carbon steel (AISI 1010) shafts of 0.1 m diameter are heat treated in a gas-fired furnace whose gases are at 1200 K and provide a convection coefficient of $100 \text{ W/m}^2 \cdot \text{K}$. If the shafts enter the furnace at 300 K, how long must they remain in the furnace to achieve a centerline temperature of 800 K?
- 5.10 A thermal energy storage unit consists of a large rectangular channel, which is well insulated on its outer surface and encloses alternating layers of the storage material and the flow passage.

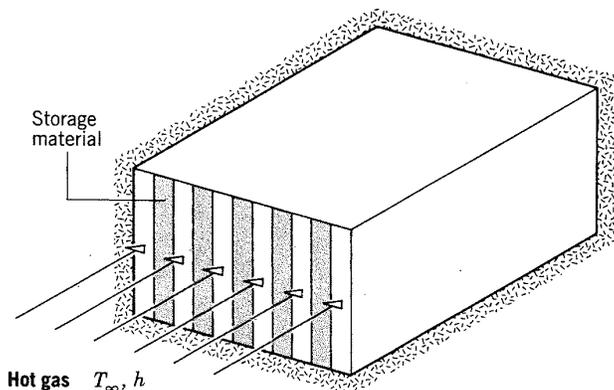

Each layer of the storage material is an aluminum slab of width $W = 0.05 \text{ m}$, which is at an initial temperature of 25°C . Consider conditions for which the storage unit is charged by passing a hot gas through the passages, with the gas temperature and the convection coefficient assumed to have constant values of $T_\infty = 600^\circ\text{C}$ and $h = 100 \text{ W/m}^2 \cdot \text{K}$ throughout the channel. How long will it take to achieve 75% of the maximum possible energy storage? What is the temperature of the aluminum at this time?

- 5.11 A leaf spring of dimensions 32 mm by 10 mm by 1.1 m is sprayed with a thin anticorrosion coating which is heat treated by suspending the spring vertically in the lengthwise direction and passing it through a conveyor oven maintained at an air temperature of 175°C . Satisfactory coatings have been obtained on springs, initially at 25°C , with an oven residence time of 35 min. The coating supplier has specified that the coating should be treated for 10 min above a temperature of 140°C . How long should a spring of dimensions 76 mm by 35 mm by 1.6 m remain in the oven in order to properly heat treat the coating? The thermophysical properties of the spring material are $\rho = 8131 \text{ kg/m}^3$, $c_p = 473 \text{ J/kg} \cdot \text{K}$, and $k = 42 \text{ W/m} \cdot \text{K}$.
- 5.12 A 3-mm-thick panel of aluminum alloy ($k = 177 \text{ W/m} \cdot \text{K}$ and $\alpha = 73 \times 10^{-6} \text{ m}^2/\text{s}$) is finished on both sides with an epoxy coating that must be cured at or above 150°C for at least 5 min. The production line for the curing operation involves two steps: (1) heating in an oven with air at 175°C and a convection

1 number of
bullet to 700
the air and the
1 the time of

in a gas-fired
icient of 100
ey remain in

nel, which is
f the storage

$W = 0.05$ m,
or which the
with the gas
ant values of
 v long will it
What is the

1 with a thin
; vertically in
ntained at an
d on springs,
; supplier has
mperature of
m by 1.6 m
thermophys-
/kg · K, and

$= 73 \times 10^{-6}$
e cured at or
ng operation
a convection

coefficient of $20 \text{ W/m}^2 \cdot \text{K}$, and (2) cooling in an enclosure with air at 25°C and a convection coefficient of $10 \text{ W/m}^2 \cdot \text{K}$.

- (a) Assuming the panel is initially at 25°C , what is the minimum residence time for the panel in the oven?
- (b) What is the total elapsed time for the two-step curing operation if it is completed when the panel has been cured and cooled to the *safe-to-touch* temperature of 37°C ?

5.13 A plane wall of a furnace is fabricated from plain carbon steel ($k = 60 \text{ W/m} \cdot \text{K}$, $\rho = 7850 \text{ kg/m}^3$, $c = 430 \text{ J/kg} \cdot \text{K}$) and is of thickness $L = 10 \text{ mm}$. To protect it from the corrosive effects of the furnace combustion gases, one surface of the wall is coated with a thin ceramic film which, for a unit surface area, has a thermal resistance of $R''_{t,f} = 0.01 \text{ m}^2 \cdot \text{K/W}$. The opposite surface is well insulated from the surroundings.

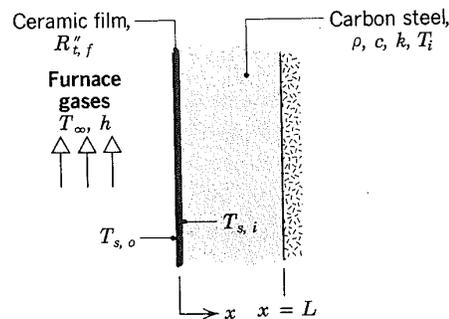

At furnace start-up the wall is at an initial temperature of $T_i = 300 \text{ K}$, and combustion gases at $T_\infty = 1300 \text{ K}$ enter the furnace, providing a convection coefficient of $h = 25 \text{ W/m}^2 \cdot \text{K}$ at the ceramic film. Assuming the film to have negligible thermal capacitance, how long will it take for the inner surface of the steel to achieve a temperature of $T_{s,i} = 1200 \text{ K}$? What is the temperature $T_{s,o}$ of the exposed surface of the ceramic film at this time?

- 5.14 In an industrial process requiring high dc currents, water-jacketed copper rods, 20 mm in diameter, are used to carry the current. The water, which flows continuously between the jacket and the rod, maintains the rod temperature at 75°C during normal operation at 1000 A. The electrical resistance of the rod is known to be $0.15 \Omega/\text{m}$. Problems would arise if the coolant water ceased to be available (e.g. because of a valve malfunction). In such a situation heat transfer from the rod surface would diminish greatly, and the rod would eventually melt. Estimate the time required for melting to occur.
- 5.15 A long wire of diameter $D = 1 \text{ mm}$ is submerged in an oil bath of temperature $T_\infty = 25^\circ\text{C}$. The wire has an electrical resistance per unit length of $R'_e = 0.01 \Omega/\text{m}$. If a current of $I = 100 \text{ A}$ flows through the wire and the convection coefficient is $h = 500 \text{ W/m}^2 \cdot \text{K}$, what is the steady-state temperature of the wire? From the time the current is applied, how long does it take for the wire to reach a temperature which is within 1°C of the steady-state value? The properties of the wire are $\rho = 8000 \text{ kg/m}^3$, $c = 500 \text{ J/kg} \cdot \text{K}$, and $k = 20 \text{ W/m} \cdot \text{K}$.
- 5.16 Consider the system of Problem 5.1 where the temperature of the plate is spacewise isothermal during the transient process.

- (a) Obtain an expression for the temperature of the plate as a function of time $T(t)$ in terms of q_o'', T_∞, h, L , and the plate properties ρ and c .
- (b) Determine the thermal time constant and the steady-state temperature for a 12-mm-thick plate of pure copper when $T_\infty = 27^\circ\text{C}$, $h = 50 \text{ W/m}^2 \cdot \text{K}$, and $q_o'' = 5000 \text{ W/m}^2$. Estimate the time required to reach steady-state conditions.
- 5.17 An electronic device, such as a power transistor mounted on a finned heat sink, can be modeled as a spatially isothermal object with internal heat generation and an external convection resistance.

- (a) Consider such a system of mass M , specific heat c , and surface area A_s , which is initially in equilibrium with the environment at T_∞ . Suddenly, the electronic device is energized such that a constant heat generation \dot{E}_g (W) occurs. Show that the temperature response of the device is

$$\frac{\theta}{\theta_i} = \exp\left(-\frac{t}{RC}\right)$$

where $\theta \equiv T - T(\infty)$ and $T(\infty)$ is the steady-state temperature corresponding to $t \rightarrow \infty$; $\theta_i = T_i - T(\infty)$; T_i = initial temperature of device; R = thermal resistance $1/hA_s$; and C = thermal capacitance Mc .

- (b) An electronic device, which generates 60 W of heat, is mounted on an aluminum heat sink weighing 0.31 kg and reaches a temperature of 100°C in ambient air at 20°C under steady-state conditions. If the device is initially at 20°C , what temperature will it reach 5 min after the power is switched on?
- 5.18 Before being injected into a furnace, pulverized coal is preheated by passing it through a cylindrical tube whose surface is maintained at $T_{\text{sur}} = 1000^\circ\text{C}$. The coal pellets are suspended in an airflow and are known to move with a speed of 3 m/s. If the pellets may be approximated as spheres of 1-mm diameter and it may be assumed that they are heated by radiation transfer from the tube surface, how long must the tube be to heat coal entering at 25°C to a temperature of 600°C ? Is the use of the lumped capacitance method justified?
- 5.19 A metal sphere of diameter D , which is at a uniform temperature T_i , is suddenly removed from a furnace and suspended from a fine wire in a large room with air at a uniform temperature T_∞ and the surrounding walls at a temperature T_{sur} .
- (a) Neglecting heat transfer by radiation, obtain an expression for the time required to cool the sphere to some temperature T .
- (b) Neglecting heat transfer by convection, obtain an expression for the time required to cool the sphere to the temperature T .
- (c) How would you go about determining the time required for the sphere to cool to the temperature T if both convection and radiation are of the same order of magnitude?
- (d) Consider an anodized aluminum sphere ($\varepsilon = 0.75$) 50 mm in diameter, which is at an initial temperature of $T_i = 800 \text{ K}$. Both the air and the surroundings are at 300 K, and the convection coefficient is $10 \text{ W/m}^2 \cdot \text{K}$. Calculate and compare the time it will take for the sphere to cool to 400 K using the results of parts a, b, and c.
- 5.20 As permanent space stations increase in size, there is an attendant increase in the amount of electrical power they dissipate. To keep station compartment temperatures from exceeding prescribed limits, it is necessary to transfer the dissipated

heat to space. A novel heat rejection scheme that has been proposed for this purpose is termed a Liquid Droplet Radiator (LDR). The heat is first transferred to a high vacuum oil, which is then injected into outer space as a stream of small droplets. The stream is allowed to traverse a distance L , over which it cools by radiating energy to outer space at absolute zero temperature. The droplets are then collected and routed back to the space station.

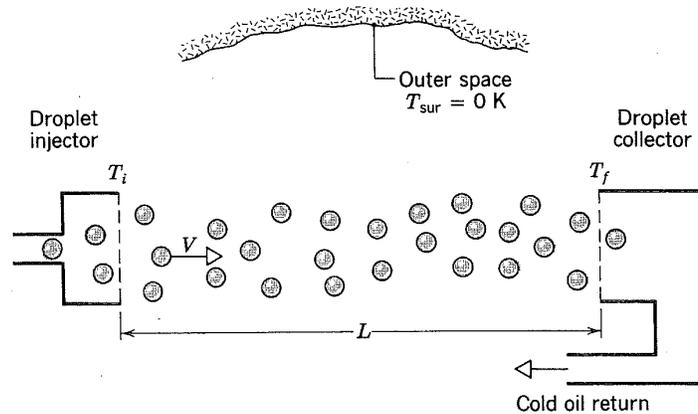

Consider conditions for which droplets of emissivity $\epsilon = 0.95$ and diameter $D = 0.5$ mm are injected at a temperature of $T_i = 500$ K and a velocity of $V = 0.1$ m/s. Properties of the oil are $\rho = 885$ kg/m³, $c = 1900$ J/kg · K, and $k = 0.145$ W/m · K. Assuming each drop to radiate to deep space at $T_{sur} = 0$ K, determine the distance L required for the droplets to impact the collector at a final temperature of $T_f = 300$ K. What is the amount of thermal energy rejected by each droplet?

- 5.21 Long metallic rods of circular cross section are heat treated by passing an electric current through the rods to provide uniform volumetric heat generation at a rate \dot{q} (W/m³). The rods are of diameter D and are placed in a large chamber whose walls are maintained at the same temperature T_∞ as the enclosed air. Convection from the surface of the rods to the air is characterized by the coefficient h .
- Obtain an expression that could be used to determine the steady-state temperature of the rod.
 - Neglecting radiation and prescribing an initial ($t = 0$) rod temperature of $T_i = T_\infty$, obtain the transient temperature response of the rod.
- 5.22 A chip that is of length $L = 5$ mm on a side and thickness $t = 1$ mm is encased in a ceramic substrate, and its exposed surface is convectively cooled by a dielectric liquid for which $h = 150$ W/m² · K and $T_\infty = 20^\circ\text{C}$.

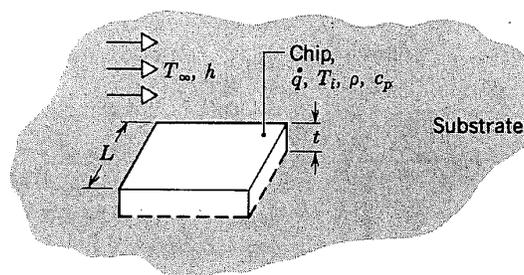

tion of time

perature for a
m² · K, and
conditions.
d heat sink,
eration and

na A_s , which
he electronic
occurs. Show

correspond-
levise; $R =$

nted on an
of 100°C in
is initially at
itched on?

y passing it
 $^\circ\text{C}$. The coal
ed of 3 m/s.
d it may be
surface, how
of 600°C ? Is

, is suddenly
oom with air
ture T_{sur} .
for the time

for the time

where to cool
same order

meter, which
surroundings
calculate and
g the results

crease in the
ent tempera-
re dissipated

In the off-mode the chip is in thermal equilibrium with the coolant ($T_i = T_\infty$). When the chip is energized, however, its temperature increases until a new steady-state is established. For purposes of analysis, the energized chip is characterized by uniform volumetric heating with $\dot{q} = 9 \times 10^6 \text{ W/m}^3$. Assuming an infinite contact resistance between the chip and substrate and negligible conduction resistance within the chip, determine the steady-state chip temperature T_f . Following activation of the chip, how long does it take to come within 1°C of this temperature? The chip density and specific heat are $\rho = 2000 \text{ kg/m}^3$ and $c = 700 \text{ J/kg} \cdot \text{K}$, respectively.

- 5.23 Consider the conditions of Problem 5.22. In addition to treating heat transfer by convection directly from the chip to the coolant, a more realistic analysis would account for indirect transfer from the chip to the substrate and then from the substrate to the coolant. The total thermal resistance associated with this indirect route includes contributions due to the chip-substrate interface (a contact resistance), multidimensional conduction in the substrate, and convection from the surface of the substrate to the coolant. If this total thermal resistance is $R_t = 200 \text{ K/W}$, what is the steady-state chip temperature T_f ? Following activation of the chip, how long does it take to come within 1°C of this temperature?

One-Dimensional Conduction: The Plane Wall

- 5.24 Consider the series solution, Equation 5.39, for the plane wall with convection. Calculate midplane ($x^* = 0$) and surface ($x^* = 1$) temperatures θ^* for $Fo = 0.1$ and 1, using $Bi = 0.1, 1,$ and 10. Consider only the first four eigenvalues. Based on these results discuss the validity of the approximate solutions, Equations 5.40 and 5.41.
- 5.25 Consider the one-dimensional wall shown in the sketch which is initially at a uniform temperature T_i and is suddenly subjected to the convection boundary condition with a fluid at T_∞ .

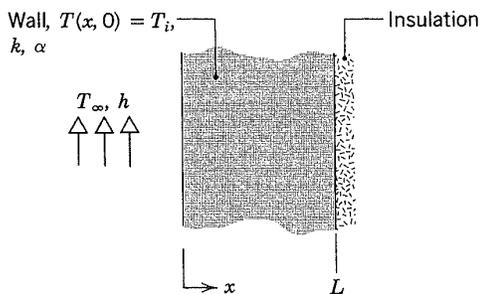

For a particular wall, case 1, the temperature at $x = L_1$ after $t_1 = 100 \text{ s}$ is $T_1(L_1, t_1) = 315^\circ\text{C}$. Another wall, case 2, has different thickness and thermal conditions as shown below.

CASE	L (m)	α (m^2/s)	k ($\text{W}/\text{m} \cdot \text{K}$)	T_i ($^\circ\text{C}$)	T_∞ ($^\circ\text{C}$)	h ($\text{W}/\text{m}^2 \cdot \text{K}$)
1	0.10	15×10^{-6}	50	300	400	200
2	0.40	25×10^{-6}	100	30	20	100

H
U
tr
5.26 A
te
8(
W
(a
(b
(c
5.27 A
ta
ti
th
te
T
h
5.28 A
te
 α
c
ti
5.29 C
r
p
p
th
5.30 T
a
E
e
T

(
-
(

I
7
n
5.31 I
i

at ($T_i = T_\infty$).
 until a new
 tip is charac-
 Assuming an
 ible conduc-
 nperature T_f .
 n 1°C of this
 and $c = 700$

it transfer by
 alysis would
 en from the
 this indirect
 contact resis-
 ion from the
 is $R_f = 200$
 vation of the

1 convection.
 for $Fo = 0.1$
 values. Based
 quations 5.40

initially at a
 on boundary

$t_1 = 100$ s is
 and thermal

$/\text{m}^2 \cdot \text{K}$)

How long will it take for the second wall to reach 28.5°C at the position $x = L_2$? Use as the basis for analysis, the dimensionless functional dependence for transient temperature distribution as expressed in Equation 5.26.

- 5.26 A large aluminum (2024 alloy) plate of thickness 0.15 m, initially at a uniform temperature of 300 K, is placed in a furnace having an ambient temperature of 800 K for which the convection heat transfer coefficient is estimated to be $500 \text{ W/m}^2 \cdot \text{K}$.
- Determine the time required for the plate midplane to reach 700 K.
 - What is the surface temperature of the plate for this condition?
 - Repeat the calculations if the material were stainless steel (type 304).
- 5.27 After a long, hard week on the books, you and your friend are ready to relax. You take a steak 50 mm thick from the freezer. How long do you have to let the good times roll before the steak has thawed? Assume that the steak is initially at -6°C , that it thaws when the midplane temperature reaches 4°C , and that the room temperature is 23°C with a convection heat transfer coefficient of $10 \text{ W/m}^2 \cdot \text{K}$. Treat the steak as a slab having the properties of liquid water at 0°C . Neglect the heat of fusion associated with the melting phase change.
- 5.28 A one-dimensional plane wall with a thickness of 0.1 m initially at a uniform temperature of 250°C is suddenly immersed in an oil bath at 30°C . Assuming the convection heat transfer coefficient for the wall in the bath is $500 \text{ W/m}^2 \cdot \text{K}$, calculate the surface temperature of the wall 9 min after immersion. The properties of the wall are $k = 50 \text{ W/m} \cdot \text{K}$, $\rho = 7835 \text{ kg/m}^3$, and $c = 465 \text{ J/kg} \cdot \text{K}$.
- 5.29 Consider the thermal energy storage unit of Problem 5.10, but with a masonry material of $\rho = 1900 \text{ kg/m}^3$, $c = 800 \text{ J/kg} \cdot \text{K}$, and $k = 0.70 \text{ W/m} \cdot \text{K}$ used in place of the aluminum. How long will it take to achieve 75% of the maximum possible energy storage? What are the maximum and minimum temperatures of the masonry at this time?
- 5.30 The wall of a rocket nozzle is of thickness $L = 25 \text{ mm}$ and is made from a high alloy steel for which $\rho = 8000 \text{ kg/m}^3$, $c = 500 \text{ J/kg} \cdot \text{K}$, and $k = 25 \text{ W/m} \cdot \text{K}$. During a test firing, the wall is initially at $T_i = 25^\circ\text{C}$ and its inner surface is exposed to hot combustion gases for which $h = 500 \text{ W/m}^2 \cdot \text{K}$ and $T_\infty = 1750^\circ\text{C}$. The outer surface is well insulated.

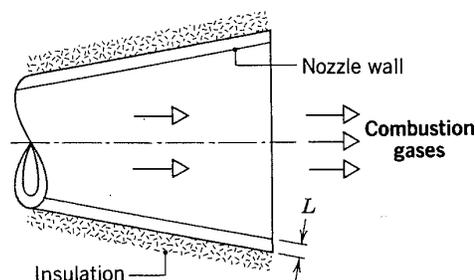

If the wall must be maintained at least 100°C below its melting point of $T_{\text{mp}} = 1600^\circ\text{C}$, what is the maximum allowable firing time t_f ? The diameter of the nozzle is much larger than its thickness L .

- 5.31 In a tempering process, glass plate, which is initially at a uniform temperature T_i , is cooled by suddenly reducing the temperature of both surfaces to T_s . The plate is

20 mm thick, and the glass has a thermal diffusivity of $6 \times 10^{-7} \text{ m}^2/\text{s}$.

- (a) How long will it take for the midplane temperature to achieve 50% of its maximum possible temperature reduction?
- (b) If $(T_i - T_s) = 300^\circ\text{C}$, what is the maximum temperature gradient in the glass at the above time?

5.32 Copper-coated, epoxy-filled fiberglass circuit boards are treated by heating a stack of them under high pressure as shown in the sketch. The purpose of the pressing-heating operation is to cure the epoxy which bonds the fiberglass sheets imparting stiffness to the boards. The stack, referred to as a *book*, is comprised of 10 *boards* and 11 *pressing plates* which prevent epoxy from flowing between the boards and impart a smooth finish to the cured boards. In order to perform simplified thermal analyses, it is reasonable to approximate the book as having an effective thermal conductivity (k) and an effective thermal capacitance (ρc_p). Calculate the effective properties if each of the boards and plates has a thickness of 2.36 mm and the following thermophysical properties: board (b) $\rho_b = 1000 \text{ kg/m}^3$, $c_{p,b} = 1500 \text{ J/kg} \cdot \text{K}$, $k_b = 0.30 \text{ W/m} \cdot \text{K}$; plate (p) $\rho_p = 8000 \text{ kg/m}^3$, $c_{p,p} = 480 \text{ J/kg} \cdot \text{K}$, $k_p = 12 \text{ W/m} \cdot \text{K}$.

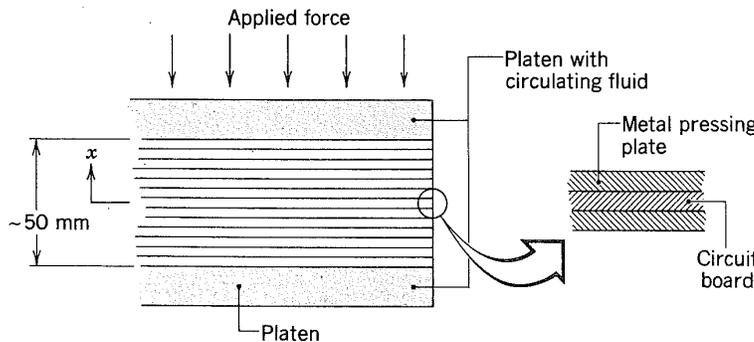

5.33 Circuit boards are treated by heating a stack of them under high pressure as illustrated in Problem 5.32. The platens at the top and bottom of the stack are maintained at a uniform temperature by a circulating fluid. The purpose of the pressing-heating operation is to cure the epoxy which bonds the fiberglass sheets and impart stiffness to the boards. The cure condition is achieved when the epoxy has been maintained at or above 170°C for at least 5 min. The effective thermophysical properties of the stack or *book* (boards and metal pressing plates) are $k = 0.613 \text{ W/m} \cdot \text{K}$ and $\rho c_p = 2.73 \times 10^6 \text{ J/m}^3 \cdot \text{K}$.

- (a) If the book is initially at 15°C and, following application of pressure, the platens are suddenly brought to a uniform temperature of 190°C , calculate the elapsed time t_e required for the midplane of the book to reach the cure temperature of 170°C .
- (b) If, at this instant of time, $t = t_e$, the platen temperature were reduced suddenly to 15°C , how much energy would have to be removed from the book by the coolant circulating in the platen, in order to return the stack to its initial uniform temperature?

One-Dime

5.34 C
d
r
F
r

5.35 E
h
V
d
c

5.36 A
c
is
c
tu
tu

5.37 A
is
c
k
r

5.38 A
n
c

5.39

5.40

One-Dimensional Conduction: The Long Cylinder

- 5.34 Cylindrical steel rods (AISI 1010), 50 mm in diameter, are heat treated by drawing them through an oven 5 m long in which air is maintained at 750°C. The rods enter at 50°C and achieve a centerline temperature of 600°C before leaving. For a convection coefficient of 125 W/m² · K, estimate the speed at which the rods must be drawn through the oven.
- 5.35 Estimate the time required to cook a hot dog in boiling water. Assume that the hot dog is initially at 6°C, that the convection heat transfer coefficient is 100 W/m² · K, and that the final temperature is 80°C at the centerline. Treat the hot dog as a long cylinder of 20-mm diameter having the properties: $\rho = 880 \text{ kg/m}^3$, $c = 3350 \text{ J/kg} \cdot \text{K}$, and $k = 0.52 \text{ W/m} \cdot \text{K}$.
- 5.36 A long rod of 60-mm diameter and thermophysical properties $\rho = 8000 \text{ kg/m}^3$, $c = 500 \text{ J/kg} \cdot \text{K}$ and $k = 50 \text{ W/m} \cdot \text{K}$ is initially at a uniform temperature and is heated in a forced convection furnace maintained at 750 K. The convection coefficient is estimated to be 1000 W/m² · K. At a certain time, the surface temperature of the rod is measured to be 550 K. What is the corresponding center temperature of the rod?
- 5.37 A long cylinder of 30-mm diameter, initially at a uniform temperature of 1000 K, is suddenly quenched in a large, constant-temperature oil bath at 350 K. The cylinder properties are $k = 1.7 \text{ W/m} \cdot \text{K}$, $c = 1600 \text{ J/kg} \cdot \text{K}$, and $\rho = 400 \text{ kg/m}^3$, while the convection coefficient is 50 W/m² · K. Calculate the time required for the surface of the cylinder to reach 500 K.
- 5.38 A long pyroceram rod of diameter 20 mm is clad with a very thin metallic tube for mechanical protection. The bonding between the rod and the tube has a thermal contact resistance of $R'_{t,c} = 0.12 \text{ m} \cdot \text{K/W}$.

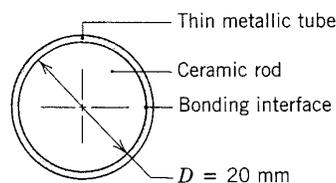

If the rod is initially at a uniform temperature of 900 K and is suddenly cooled by a fluid at $T_\infty = 300 \text{ K}$ and $h = 100 \text{ W/m}^2 \cdot \text{K}$, at what time will the rod centerline reach 600 K?

- 5.39 A long rod 40 mm in diameter, fabricated from sapphire (aluminum oxide) and initially at a uniform temperature of 800 K, is suddenly exposed to a cooling process with a fluid at 300 K having a heat transfer coefficient of 1600 W/m² · K. After 35 s of exposure to the cooling process, the rod is wrapped in insulation and experiences no heat losses. What will be the temperature of the rod after a long period of time?
- 5.40 A long bar of 70-mm diameter and initially at 90°C is cooled by immersing it in a water bath which is at 40°C and provides a convection coefficient of 20 W/m² · K. The thermophysical properties of the bar are $\rho = 2600 \text{ kg/m}^3$, $c = 1030 \text{ J/kg} \cdot \text{K}$, and $k = 3.50 \text{ W/m} \cdot \text{K}$.

- (a) How long should the bar remain in the bath in order that, when it is removed and allowed to equilibrate while isolated from any surroundings, it achieves a uniform temperature of 55°C ?
 - (b) What is the surface temperature of the bar when it is removed from the bath?
- 5.41 A long plastic rod of 30-mm diameter ($k = 0.3 \text{ W/m} \cdot \text{K}$ and $\rho c_p = 1040 \text{ kJ/m}^3 \cdot \text{K}$) is uniformly heated in an oven as preparation for a pressing operation. For best results, the temperature in the rod should not be less than 200°C . To what uniform temperature should the rod be heated in the oven if, for the worst case, the rod sits on a conveyor for 3 min while exposed to convection cooling with ambient air at 25°C and with a convection coefficient of $8 \text{ W/m}^2 \cdot \text{K}$? A further condition for good results is a maximum-minimum temperature difference of less than 10°C . Is this condition satisfied and, if not, what could you do to satisfy it?

One-Dimensional Conduction: The Sphere

- 5.42 In heat treating to harden steel ball bearings ($c = 500 \text{ J/kg} \cdot \text{K}$, $\rho = 7800 \text{ kg/m}^3$, $k = 50 \text{ W/m} \cdot \text{K}$), it is desirable to increase the surface temperature for a short time without significantly warming the interior of the ball. This type of heating can be accomplished by sudden immersion of the ball in a molten salt bath with $T_{\infty} = 1300 \text{ K}$ and $h = 5000 \text{ W/m}^2 \cdot \text{K}$. Assume that any location within the ball whose temperature exceeds 1000 K will be hardened. Estimate the time required to harden the outer millimeter of a ball of diameter 20 mm , if its initial temperature is 300 K .
- 5.43 A sphere of 80-mm diameter ($k = 50 \text{ W/m} \cdot \text{K}$ and $\alpha = 1.5 \times 10^{-6} \text{ m}^2/\text{s}$) is initially at a uniform, elevated temperature and is quenched in an oil bath maintained at 50°C . The convection coefficient for the cooling process is $1000 \text{ W/m}^2 \cdot \text{K}$. At a certain time, the surface temperature of the sphere is measured to be 150°C . What is the corresponding center temperature of the sphere?
- 5.44 A cold air chamber is proposed for quenching steel ball bearings of diameter $D = 0.2 \text{ m}$ and initial temperature $T_i = 400^{\circ}\text{C}$. Air in the chamber is maintained at -15°C by a refrigeration system, and the steel balls pass through the chamber on a conveyor belt. Optimum bearing production requires that 70% of the initial thermal energy content of the ball above -15°C be removed. Radiation effects may be neglected, and the convection heat transfer coefficient within the chamber is $1000 \text{ W/m}^2 \cdot \text{K}$. Estimate the residence time of the balls within the chamber, and recommend a drive velocity of the conveyor. The following properties may be used for the steel: $k = 50 \text{ W/m} \cdot \text{K}$, $\alpha = 2 \times 10^{-5} \text{ m}^2/\text{s}$, and $c = 450 \text{ J/kg} \cdot \text{K}$.

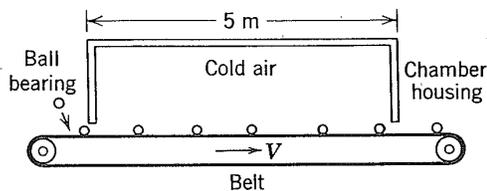

- 5.45 Stainless steel (AISI 304) ball bearings, which have been uniformly heated to 850°C , are hardened by quenching them in an oil bath that is maintained at 40°C . The ball diameter is 20 mm , and the convection coefficient associated with the oil bath is $1000 \text{ W/m}^2 \cdot \text{K}$.

it is removed
s, it achieves a

from the bath?
d $\rho c_p = 1040$
ressing opera-
s than 200°C .
ven if, for the
to convection
 $8 \text{ W/m}^2 \cdot \text{K}$?
erature differ-
ould you do to

$= 7800 \text{ kg/m}^3$,
ire for a short
ype of heating
salt bath with
within the ball
time required
, if its initial

$10^{-6} \text{ m}^2/\text{s}$ is
an oil bath
rocess is 1000
is measured to
ere?

5s of diameter
is maintained
h the chamber
 $\frac{1}{2}$ of the initial
adiation effects
n the chamber
t the chamber,
erties may be
 $450 \text{ J/kg} \cdot \text{K}$.

mly heated to
ained at 40°C .
ed with the oil

- (a) If quenching is to occur until the surface temperature of the balls reaches 100°C , how long must the balls be kept in the oil? What is the center temperature at the conclusion of the cooling period?
- (b) If 10,000 balls are to be quenched per hour, what is the rate at which energy must be removed by the oil bath cooling system in order to maintain its temperature at 40°C ?
- 5.46 A spherical hailstone that is 5 mm in diameter is formed in a high altitude cloud at -30°C . If the stone begins to fall through warmer air at 5°C , how long will it take before the outer surface begins to melt? What is the temperature of the stone's center at this point in time, and how much energy (J) has been transferred to the stone? A convection heat transfer coefficient of $250 \text{ W/m}^2 \cdot \text{K}$ may be assumed, and the properties of the hailstone may be taken to be those of ice.
- 5.47 A sphere 30 mm in diameter initially at 800 K is quenched in a large bath having a constant temperature of 320 K with a convection heat transfer coefficient of $75 \text{ W/m}^2 \cdot \text{K}$. The thermophysical properties of the sphere material are: $\rho = 400 \text{ kg/m}^3$, $c = 1600 \text{ J/kg} \cdot \text{K}$, and $k = 1.7 \text{ W/m} \cdot \text{K}$.
- (a) Show, in a qualitative manner on $T-t$ coordinates, the temperatures at the center and at the surface of the sphere as a function of time.
- (b) Calculate the time required for the surface of the sphere to reach 415 K.
- (c) Determine the heat flux (W/m^2) at the outer surface of the sphere at the time determined in part b.
- (d) Determine the energy (J) that has been lost by the sphere during the process of cooling to the surface temperature of 415 K.
- (e) At the time determined by part b, the sphere is quickly removed from the bath and covered with perfect insulation, such that there is no heat loss from the surface of the sphere. What will be the temperature of the sphere after a long period of time has elapsed?
- 5.48 Spheres A and B are initially at 800 K, and they are simultaneously quenched in large constant temperature baths, each having a temperature of 320 K. The following parameters are associated with each of the spheres and their cooling processes.

	SPHERE A	SPHERE B
Diameter (mm)	300	30
Density (kg/m^3)	1600	400
Specific heat ($\text{kJ/kg} \cdot \text{K}$)	0.400	1.60
Thermal conductivity ($\text{W/m} \cdot \text{K}$)	170	1.70
Convection coefficient ($\text{W/m}^2 \cdot \text{K}$)	5	50

- (a) Show in a qualitative manner, on T versus t coordinates, the temperatures at the center and at the surface for each sphere as a function of time. Briefly explain the reasoning by which you determine the relative positions of the curves.
- (b) Calculate the time required for the surface of each sphere to reach 415 K.

- (c) Determine the energy that has been gained by each of the baths during the process of the spheres cooling to 415 K.
- 5.49 The convection coefficient for flow over a solid sphere may be determined by submerging the sphere, which is initially at 25°C, into the flow, which is at 75°C, and measuring its surface temperature at some time during the transient heating process. The sphere has a diameter of 0.1 m, and its thermal conductivity and thermal diffusivity are 15 W/m · K and 10⁻⁵ m²/s, respectively. If the convection coefficient is 300 W/m² · K, at what time will a surface temperature of 60°C be recorded?

Semi-infinite Media

- 5.50 Two large blocks of different materials, such as copper and concrete, have been sitting in a room (23°C) for a very long time. Which of the two blocks, if either, will feel colder to the touch? Assume the blocks to be semi-infinite solids and your hand to be at a temperature of 37°C.
- 5.51 Asphalt pavement may achieve temperatures as high as 50°C on a hot summer day. Assume that such a temperature exists throughout the pavement, when suddenly a rainstorm reduces the surface temperature to 20°C. Calculate the total amount of energy (J/m²) that will be transferred from the asphalt over a 30-min period in which the surface is maintained at 20°C.
- 5.52 A furnace wall is fabricated from fireclay brick ($\alpha = 7.1 \times 10^{-7}$ m²/s), and its inner surface is maintained at 1100 K during furnace operation. The wall is designed according to the criterion that, for an initial temperature of 300 K, its midpoint temperature will not exceed 325 K after 4 h of furnace operation. What is the minimum allowable wall thickness?
- 5.53 A block of material of thickness 20 mm with known thermophysical properties ($k = 15$ W/m · K and $\alpha = 2.0 \times 10^{-5}$ m²/s) is imbedded in the wall of a channel that is initially at 25°C and is suddenly subjected to a convection process with gases at 325°C. A thermocouple (TC) is installed 2 mm below the surface of the channel wall for the purpose of sensing the temperature–time history (following start-up of the hot gas flow) and thereby determining the transient heat flux. At an elapsed time of 10 s, the thermocouple indicates a temperature of 167°C.

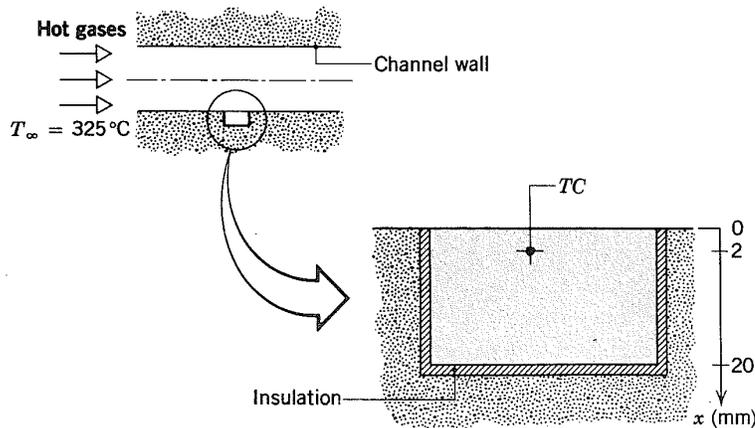

Ca
be
He
5.54 A
ele
all
suf
exc
to
pro
5.55 Th
cla
c_p,
thi
con
ini
ter
cas
cal
T₁
De
ca
dr
ap
5.56 A
in
pc
re

this during the

determined by
 which is at 75°C,
 transient heating
 conductivity and
 If the convective
 temperature of 60°C

crete, have been
 locks, if either,
 solids and your

a hot summer
 movement, when
 calculate the total
 over a 30-min

m²/s), and its
 n. The wall is
 e of 300 K, its
 operation. What

sical properties
 the wall of a
 convection process
 v the surface of
 history (follow-
 sient heat flux.
 ture of 167°C.

Calculate the corresponding surface convective heat flux assuming the block behaves as a semi-infinite solid. Compare this result with that obtained from the Heisler method of solution.

- 5.54 A tile-iron consists of a massive plate maintained at 150°C by an imbedded electrical heater. The iron is placed in contact with a tile to soften the adhesive, allowing the tile to be easily lifted from the subflooring. The adhesive will soften sufficiently if heated above 50°C for at least 2 min, but its temperature should not exceed 120°C to avoid deterioration of the adhesive. Assume the tile and subfloor to have an initial temperature of 25°C and to have equivalent thermophysical properties of $k = 0.15 \text{ W/m} \cdot \text{K}$ and $\rho c_p = 1.5 \times 10^6 \text{ J/m}^3 \cdot \text{K}$.

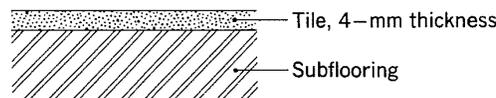

- (a) How long will it take a worker using the tile-iron to lift a tile? Will the adhesive temperature exceed 120°C?
 (b) If the tile-iron has a square surface area 254 mm to the side, how much energy has been removed from it during the time it has taken to lift the tile?

- 5.55 The manufacturer of the heat flux gage of the type illustrated in Problem 1.8 claims the time constant for a 63.2% response to be $\tau = (4d^2\rho c_p)/\pi^2 k$, where ρ , c_p , and k are the thermophysical properties of the gage material and d is its thickness. Not knowing the origin of this relation, your task is to model the gage considering the two extreme cases illustrated below. In both cases, the gage, initially at a uniform temperature T_i , is exposed to a sudden change in surface temperature, $T(0, t) = T_s$. For case a the backside of the gage is insulated, and for case b the gage is imbedded in a semi-infinite solid having the same thermophysical properties as those of the gage.

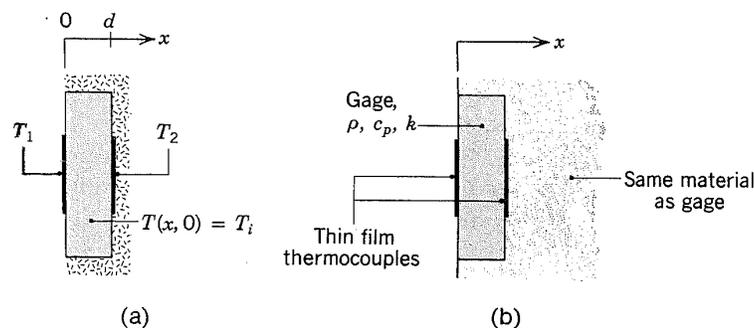

Develop relationships for predicting the time constant of the gage for the two cases and compare them to the manufacturer's relation. What conclusion can you draw from this analysis regarding the transient response of gages for different applications?

- 5.56 A simple procedure for measuring surface convection heat transfer coefficients involves coating the surface with a thin layer of material having a precise melting point temperature. The surface is then heated and, by determining the time required for melting to occur, the convection coefficient is determined. The

following experimental arrangement uses the procedure to determine the convection coefficient for gas flow normal to a surface. Specifically, a long copper rod is encased in a super insulator of very low thermal conductivity, and a very thin coating is applied to its exposed surface.

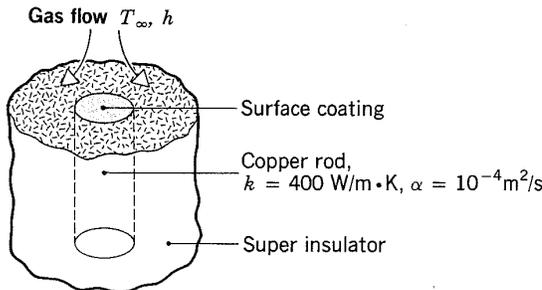

If the rod is initially at 25°C and gas flow for which $h = 200 \text{ W/m}^2 \cdot \text{K}$ and $T_\infty = 300^\circ\text{C}$ is initiated, what is the melting point temperature of the coating if melting is observed to occur at $t = 400 \text{ s}$?

- 5.57 An insurance company has hired you as a consultant to improve their understanding of burn injuries. They are especially interested in injuries induced when a portion of a worker's body comes into contact with machinery that is at elevated temperatures in the range of 50 to 100°C. Their medical consultant informs them that irreversible thermal injury (cell death) will occur in any living tissue that is maintained at $T \geq 48^\circ\text{C}$ for a duration $\Delta t \geq 10 \text{ s}$. They want information concerning the extent of irreversible tissue damage (as measured by distance from the skin surface) as a function of the machinery temperature and the time during which contact is made between the skin and the machinery. Can you help them? Assume that living tissue has a normal temperature of 37°C, is isotropic, and has constant properties equivalent to those of liquid water.
- 5.58 A procedure for determining the thermal conductivity of a solid material involves embedding a thermocouple in a thick slab of the solid and measuring the response to a prescribed change in temperature at one surface. Consider an arrangement for which the thermocouple is embedded 10 mm from a surface that is suddenly brought to a temperature of 100°C by exposure to boiling water. If the initial temperature of the slab was 30°C and the thermocouple measures a temperature of 65°C, 2 min after the surface is brought to 100°C, what is its thermal conductivity? The density and specific heat of the solid are known to be 2200 kg/m³ and 700 J/kg · K.
- 5.59 An electric heater in the form of a sheet is placed in good contact with the surface of a thick slab of Bakelite having a uniform temperature of 300 K. Determine the temperature of the slab at the surface and at a depth of 25 mm, 10 min after the heater has been energized and is providing a constant heat flux to the surface of 2500 W/m².
- 5.60 A very thick slab with thermal diffusivity $5.6 \times 10^{-6} \text{ m}^2/\text{s}$ and thermal conductivity 20 W/m · K is initially at a uniform temperature of 325°C. Suddenly, the surface is exposed to a coolant at 15°C for which the convection heat transfer coefficient is 100 W/m² · K. Determine the temperatures at the surface and at a depth of 45 mm after 3 min has elapsed.

- 5.61 A ti
800
igni
bet
- 5.62 It i
ma
glas
init
kg/
cop
- 5.63 Tw
eac
wh
tur

Multidimen

- 5.64 A l
at :
tur
10C
ten
- 5.65 Fir
16C
tur
- 5.66 A
uni
hea
cyl
anc

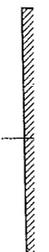

- (a)
(b)

- 5.67 Re
po

ine the convec-
g copper rod is
nd a very thin

$W/m^2 \cdot K$ and
f the coating if

eir understand-
nduced when a
at is at elevated
it informs them
ig tissue that is
nt information
y distance from
the time during
you help them?
otropic, and has

aterial involves
ng the response
an arrangement
that is suddenly
er. If the initial
s a temperature
is its thermal
own to be 2200

with the surface
. Determine the
10 min after the
o the surface of

hermal conduc-
. Suddenly, the
on heat transfer
surface and at a

- 5.61 A thick oak wall initially at 25°C , is suddenly exposed to combustion products at 800°C . Determine the time of exposure required for the surface to reach the ignition temperature of 400°C , assuming the convection heat transfer coefficient between the wall and products to be $20 \text{ W/m}^2 \cdot \text{K}$.
- 5.62 It is well known that, although two materials are at the same temperature, one may feel cooler to the touch than the other. Consider thick plates of copper and glass, each at an initial temperature of 300 K . Assuming your finger to be at an initial temperature of 310 K and to have thermophysical properties of $\rho = 1000 \text{ kg/m}^3$, $c = 4180 \text{ J/kg} \cdot \text{K}$ and $k = 0.625 \text{ W/m} \cdot \text{K}$, determine whether the copper or the glass will feel cooler to the touch.
- 5.63 Two stainless steel plates ($\rho = 8000 \text{ kg/m}^3$, $c = 500 \text{ J/kg} \cdot \text{K}$, $k = 15 \text{ W/m} \cdot \text{K}$), each 20 mm thick and insulated on one surface, are initially at 400 and 300 K when they are pressed together at their uninsulated surfaces. What is the temperature of the insulated surface of the hot plate after 1 min has elapsed?

Multidimensional Conduction

- 5.64 A long steel (plain carbon) billet of square cross section 0.3 m by 0.3 m , initially at a uniform temperature of 30°C , is placed in a soaking oven having a temperature of 750°C . If the convection heat transfer coefficient for the heating process is $100 \text{ W/m}^2 \cdot \text{K}$, how long must the billet remain in the oven before its center temperature reaches 600°C ?
- 5.65 Fireclay brick of dimensions $0.06 \text{ m} \times 0.09 \text{ m} \times 0.20 \text{ m}$ is removed from a kiln at 1600 K and cooled in air at 40°C with $h = 50 \text{ W/m}^2 \cdot \text{K}$. What is the temperature at the center and at the corners of the brick after 50 min of cooling?
- 5.66 A cylindrical copper pin 100 mm long and 50 mm in diameter is initially at a uniform temperature of 20°C . The end faces are suddenly subjected to an intense heating rate that raises them to a temperature of 500°C . At the same time, the cylindrical surface is subjected to heating by gas flow with a temperature 500°C and a heat transfer coefficient $100 \text{ W/m}^2 \cdot \text{K}$.

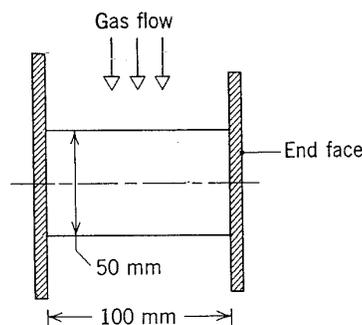

- (a) Determine the temperature at the center point of the cylinder 8 s after sudden application of the heat.
- (b) Considering the parameters governing the temperature distribution in transient heat diffusion problems, can any simplifying assumptions be justified in analyzing this particular problem? Explain briefly.
- 5.67 Recalling that your mother once said that meat should be cooked until every portion has attained a temperature of 80°C , how long will it take to cook a

2.25-kg roast? Assume that the meat is initially at 6°C and that the oven temperature is 175°C with a convection heat transfer coefficient of 15 W/m² · K. Treat the roast as a cylinder with properties of liquid water, having a diameter equal to its length.

- 5.68 A long rod 20 mm in diameter is fabricated from alumina (polycrystalline aluminum oxide) and is initially at a uniform temperature of 850 K. The rod is suddenly exposed to fluid at 350 K with $h = 500 \text{ W/m}^2 \cdot \text{K}$. Estimate the centerline temperature of the rod after 30 s at an exposed end and at an axial distance of 6 mm from the end.

Finite-Difference Solutions

- 5.69 The stability criterion for the explicit method requires that the coefficient of the T_m^p term of the one-dimensional, finite-difference equation be zero or positive. Consider the situation for which the temperatures at the two neighboring nodes (T_{m-1}^p, T_{m+1}^p) are 100°C while the center node (T_m^p) is at 50°C. Show that for values of $Fo > \frac{1}{2}$, the finite-difference equation will predict a value of T_m^{p+1} that violates the second law of thermodynamics.
- 5.70 A thin rod of diameter D is initially in equilibrium with its surroundings, a large vacuum enclosure at temperature, T_{sur} . Suddenly an electrical current I (A) is passed through the rod having an electrical resistivity ρ_e and emissivity ϵ . Other pertinent thermophysical properties are identified in the sketch. Derive the transient, finite-difference equation for node m .

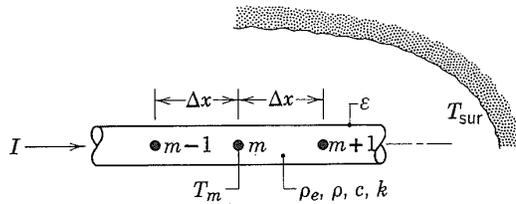

- 5.71 A tantalum rod of diameter 3 mm and length 120 mm is supported by two electrodes within a large vacuum enclosure. Initially the rod is in equilibrium with the electrodes and its surroundings, which are maintained at 300 K. Suddenly, an electrical current, $I = 80 \text{ A}$, is passed through the rod. Assume the emissivity of the rod is 0.1 and the electrical resistivity is $95 \times 10^{-8} \Omega \cdot \text{m}$. Use Table A.1 to obtain the other thermophysical properties required in your solution. Use a finite-difference method with a space increment of 10 mm.

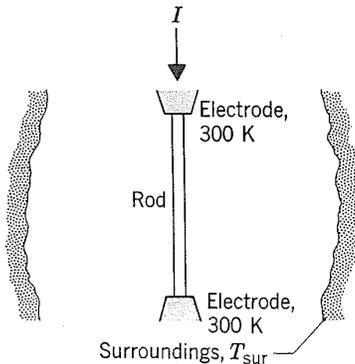

(a)
(b)

5.72 A c
Suc
hea
to

T_∞
↑
 Δz

Wr
loc
any

5.73 A
a v
20'
spa
ter

5.74 A
its
hig
ter
an
ter
yo

5.75 A
tiv
su
cc
in
at

5.76 C
te
in
W
W
th

5.77 A
 \dot{q}
h
ca
th
n

that the oven
of $15 \text{ W/m}^2 \cdot \text{K}$.
having a diameter

(polycrystalline
 0 K . The rod is
 ζ . Estimate the
and at an axial

coefficient of the
zero or positive.
neighboring nodes
!. Show that for
ue of T_m^{p+1} that

undings, a large
current $I \text{ (A)}$ is
diffusivity ϵ . Other
tech. Derive the

pported by two
equilibrium with
 K . Suddenly, an
he emissivity of
se Table A.1 to
solution. Use a

- (a) Estimate the time required for the midlength of the rod to reach 1000 K .
- (b) Determine the steady-state temperature distribution and estimate approximately how long it will take to reach this condition.

- 5.72 A one-dimensional slab of thickness $2L$ is initially at a uniform temperature T_i . Suddenly, electric current is passed through the slab causing a uniform volumetric heating $\dot{q} \text{ (W/m}^3\text{)}$. At the same time, both outer surfaces ($x = \pm L$) are subjected to a convection process at T_∞ with a heat transfer coefficient h .

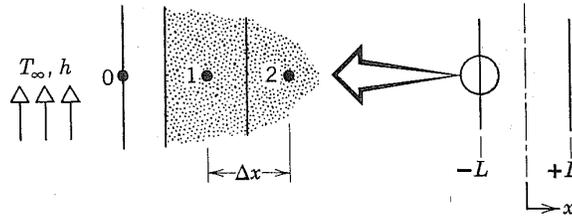

Write the finite-difference equation expressing conservation of energy for node 0 located on the outer surface at $x = -L$. Rearrange your equation and identify any important dimensionless coefficients.

- 5.73 A wall 0.12 m thick having a thermal diffusivity of $1.5 \times 10^{-6} \text{ m}^2/\text{s}$ is initially at a uniform temperature of 85°C . Suddenly one face is lowered to a temperature of 20°C , while the other face is perfectly insulated. Using a numerical method with space and time increments of 30 mm and 300 s , respectively, determine the temperature distribution within the wall after 45 min have elapsed.
- 5.74 A large plastic casting with thermal diffusivity $6.0 \times 10^{-7} \text{ m}^2/\text{s}$ is removed from its mold at a uniform temperature of 150°C . The casting is then exposed to a high-velocity airstream such that the surface experiences a sudden change in temperature to 20°C . Assuming the casting approximates a semi-infinite medium and using a finite-difference method with a space increment of 6 mm , estimate the temperature at a distance 18 mm from the surface after 3 min have elapsed. Verify your result by comparison with the appropriate analytical solution.
- 5.75 A very thick plate with thermal diffusivity $5.6 \times 10^{-6} \text{ m}^2/\text{s}$ and thermal conductivity $20 \text{ W/m} \cdot \text{K}$ is initially at a uniform temperature of 325°C . Suddenly, the surface is exposed to a coolant at 15°C for which the convection heat transfer coefficient is $100 \text{ W/m}^2 \cdot \text{K}$. Using the finite-difference method with a space increment of $\Delta x = 15 \text{ mm}$ and a time increment of 18 s , determine temperatures at the surface and at a depth of 45 mm after 3 min have elapsed.
- 5.76 Consider the fuel element of Example 5.6. Initially, the element is at a uniform temperature of 250°C with no heat generation. Suddenly, the element is inserted into the reactor core causing a uniform volumetric heat generation rate of $\dot{q} = 10^8 \text{ W/m}^3$. The surfaces are convectively cooled with $T_\infty = 250^\circ\text{C}$ and $h = 1100 \text{ W/m}^2 \cdot \text{K}$. Using the explicit method with a space increment of 2 mm , determine the temperature distribution 1.5 s after the element is inserted into the core.
- 5.77 A plane wall of thickness 100 mm with a uniform volumetric heat generation of $\dot{q} = 1.5 \times 10^6 \text{ W/m}^3$ is exposed to convection conditions of $T_\infty = 30^\circ\text{C}$ and $h = 1000 \text{ W/m}^2 \cdot \text{K}$ on both surfaces. The wall is maintained under steady-state conditions when, suddenly, the heat generation level (\dot{q}) is reduced to zero. The thermal diffusivity and thermal conductivity of the wall material are $1.6 \times 10^{-6} \text{ m}^2/\text{s}$ and $75 \text{ W/m} \cdot \text{K}$. A space increment of 10 mm is suggested.

- (a) Estimate the midplane temperature 3 min after the generation has been switched off.
 - (b) Plot on $T-x$ coordinates the temperature distribution obtained in part (a). Show also the initial and steady-state temperature distributions for the wall.
- 5.78 For the conditions described in Example 5.6, use the finite-difference method to estimate the temperature at the midplane ($x = 0$) 20 s after the power level has been changed from \dot{q}_1 to \dot{q}_2 .
- 5.79 A thin circular disk is subjected to induction heating from a coil, the effect of which is to provide a uniform heat generation within a ring section as shown. Convection occurs at the upper surface, while the lower surface is well insulated.

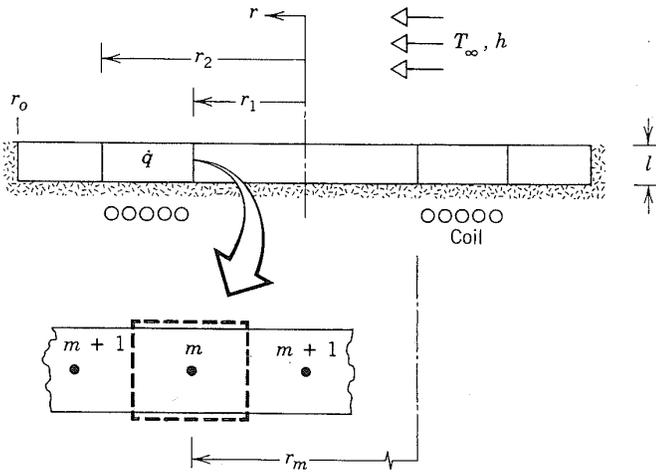

- (a) Derive the transient, finite-difference equation for node m , which is within the region subjected to induction heating.
 - (b) On $T-r$ coordinates sketch, in a qualitative manner, the steady-state temperature distribution, identifying important features.
- 5.80 An electrical cable, experiencing a uniform volumetric generation \dot{q} , is half buried in an insulating material while the upper surface is exposed to a convection process (T_∞, h).

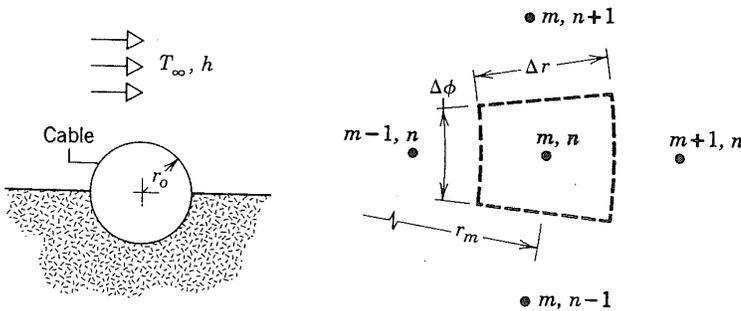

- (a) Derive the explicit, finite-difference equations for an interior node (m, n), the center node ($m = 0$), and the outer surface nodes (M, n) for the convection and insulated boundaries.
- (b) Obtain the stability criterion for each of the finite-difference equations. Identify the most restrictive criterion.

5.81 On is i
is i
slee
ren
tra
tim

5.82 Th
wic
cor
and
 h_o
cha
of
ha
10
As
ou
tin
the

5.83 T
in
ti
st
th

—
Ir
—
 $n/$
—
1
—
2
—
3
—
(ε

- 5.81 One end of a stainless steel (AISI 316) rod of diameter 10 mm and length 0.16 m is inserted into a fixture maintained at 200°C. The rod, covered with an insulating sleeve, reaches a uniform temperature throughout its length. When the sleeve is removed, the rod is subjected to ambient air at 25°C such that the convection heat transfer coefficient is 30 W/m² · K. Using a numerical technique, estimate the time required for the midlength of the rod to reach 100°C.
- 5.82 The cross section of an oven wall is composed of 30-mm-thick insulation sandwiched between two thin (1.5-mm-thick) stainless steel sheets. Under steady-state conditions, the oven is operating with an inside air temperature of $T_{\infty,i} = 150^\circ\text{C}$ and an ambient air temperature of $T_{\infty,o} = 20^\circ\text{C}$ with $h_i = 100 \text{ W/m}^2 \cdot \text{K}$ and $h_o = 10 \text{ W/m}^2 \cdot \text{K}$. When the oven heater level is changed and the fan speed changed to substantially increase air circulation within the oven, the inside surface of the oven experiences a sudden temperature change to 100°C. The insulation has a thermal conductivity of 0.03 W/m · K and a thermal diffusivity of $7.5 \times 10^{-7} \text{ m}^2/\text{s}$. In your finite-difference solution, use a space increment of 6 mm. Assume that the effect of the stainless steel sheets is negligible and that the outside convection heat transfer coefficient h_o remains unchanged. Estimate the time required for the oven wall to approximate steady-state conditions after the inner wall temperature is changed to 100°C.

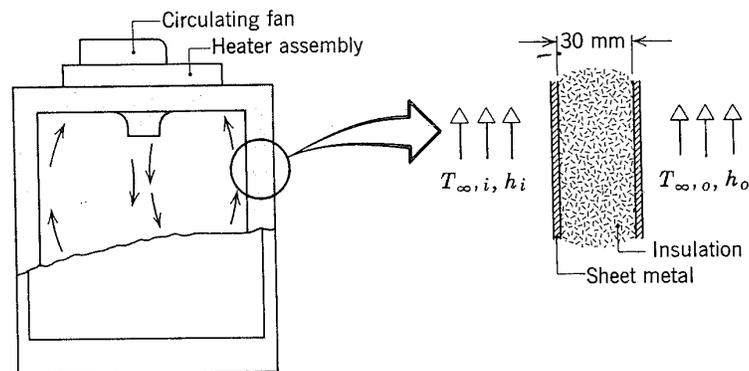

- 5.83 Two very long (in the direction normal to the page) bars having the prescribed initial temperature distributions are to be soldered together (see next page). At time $t = 0$, the $m = 3$ face of the copper (pure) bar contacts the $m = 4$ face of the steel (AISI 1010) bar. The solder and flux act as an interfacial layer of negligible thickness and effective contact resistance $R''_{i,c} = 2 \times 10^{-5} \text{ m}^2 \cdot \text{K/W}$.

Initial Temperatures (K)

n/m	1	2	3	4	5	6
1	700	700	700	1000	900	800
2	700	800	700	1000	900	800
3	700	700	700	1000	900	800

- (a) Derive the explicit, finite-difference equation in terms of Fo and $Bi_c = \Delta x/kR''_{i,c}$ for $T_{4,2}$ and determine the corresponding stability criterion.

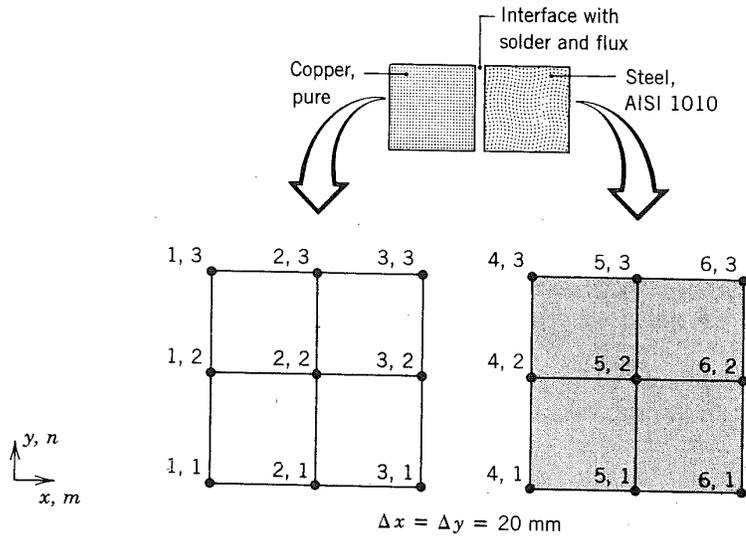

- (b) Using $Fo = 0.01$, determine $T_{4,2}$ one time step after contact is made. What is Δt ? Is the stability criterion satisfied?
- 5.84 Referring to Example 5.7, Comment 4, consider a sudden exposure of the surface to large surroundings at an elevated temperature (T_{sur}) and to convection (T_{∞}, h).
- Derive the explicit, finite-difference equation for the surface node in terms of Fo , Bi , and Bi_r .
 - Obtain the stability criterion for the surface node. Does this criterion change with time? Is the criterion more restrictive than that for an interior node?
- 5.85 Consider the system of Problem 4.58. Initially with no flue gases flowing, the walls ($\alpha = 5.5 \times 10^{-6} \text{ m}^2/\text{s}$) are at a uniform temperature of 25°C . Using the implicit, finite-difference method with a time increment of 1 h, find the temperature distribution in the wall 1, 2, 5, and 20 h after introduction of the flue gases.
- 5.86 Consider the system of Problem 4.66. Initially, the ceramic plate ($\alpha = 1.5 \times 10^{-6} \text{ m}^2/\text{s}$) is at a uniform temperature of 30°C , and suddenly the electrical heating elements are energized. Using the implicit, finite-difference method, estimate the time required for the difference between the surface and initial temperatures to reach 95% of the difference for steady-state conditions. If you write a computer program, use a time increment of 2 s; otherwise use 50 s.
- 5.87 Consider the bonding operation described in Problem 3.79, which was analyzed under steady-state conditions. In this case, however, the laser will be used to heat the film for a prescribed period of time, creating the transient heating situation shown in the sketch.



Th
W
pl
ai
(a)

(b)

5.88 C
ill
di
th
by
in
19
us
th

(c)

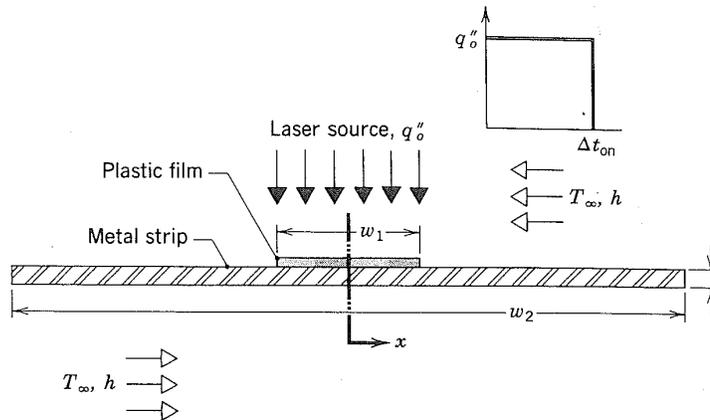

The strip is initially at 25°C and the laser provides a uniform flux of $85,000 \text{ W/m}^2$ over a time interval of $\Delta t_{\text{on}} = 10 \text{ s}$. The system dimensions and thermo-physical properties remain the same, but the convection coefficient to the ambient air at 25°C is now $100 \text{ W/m}^2 \cdot \text{K}$.

- Using an implicit finite-difference method with $\Delta x = 4 \text{ mm}$ and $\Delta t = 1 \text{ s}$, obtain temperature histories for $0 \leq t \leq 30 \text{ s}$ at the center and film edge, $T(0, t)$ and $T(w_1/2, t)$, respectively, to determine if the adhesive is satisfactorily cured above 90°C for 10 s and if its degradation temperature of 200°C is exceeded.
- Validate your program code by comparing it against the steady-state results of Problem 3.79. What type of analytical solution would you seek in order to test the proper transient behavior of your code?

5.88 Circuit boards are treated by heating a stack of them under high pressure as illustrated in Problem 5.32 and described further in Problem 5.33. A finite-difference method of solution is sought with two additional considerations. First, the book is to be treated as having distributed, rather than lumped characteristics, by using a grid spacing of $\Delta x = 2.36 \text{ mm}$ with nodes at the center of the individual circuit board or plate. Second, rather than bringing the platens to 190°C in one sudden change, the heating schedule $T_p(t)$ shown below is to be used in order to minimize excessive thermal stresses induced by rapidly changing thermal gradients in the vicinity of the platens.

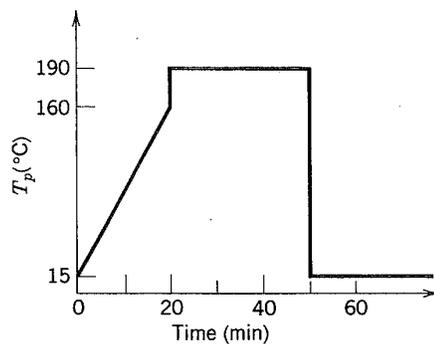

nade. What is

of the surface
convection (T_∞, h).

le in terms of

terion change
rior node?

$^2/\text{s}$, $\epsilon = 0.9$),
osed to large
ace increment
m the surface

ving, the walls
g the implicit,
: temperature
ue gases.

$= 1.5 \times 10^{-6}$
trical heating
, estimate the
peratures to
e a computer

was analyzed
e used to heat
ting situation

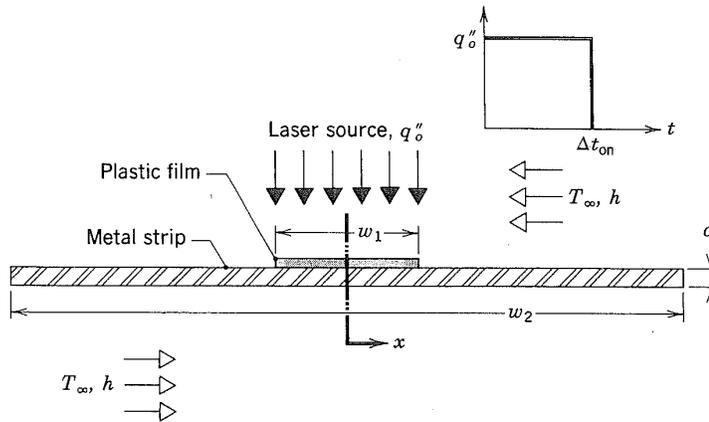

The strip is initially at 25°C and the laser provides a uniform flux of 85,000 W/m² over a time interval of $\Delta t_{on} = 10$ s. The system dimensions and thermo-physical properties remain the same, but the convection coefficient to the ambient air at 25°C is now 100 W/m² · K.

- (a) Using an implicit finite-difference method with $\Delta x = 4$ mm and $\Delta t = 1$ s, obtain temperature histories for $0 \leq t \leq 30$ s at the center and film edge, $T(0, t)$ and $T(w_1/2, t)$, respectively, to determine if the adhesive is satisfactorily cured above 90°C for 10 s and if its degradation temperature of 200°C is exceeded.
- (b) Validate your program code by comparing it against the steady-state results of Problem 3.79. What type of analytical solution would you seek in order to test the proper transient behavior of your code?

5.88 Circuit boards are treated by heating a stack of them under high pressure as illustrated in Problem 5.32 and described further in Problem 5.33. A finite-difference method of solution is sought with two additional considerations. First, the book is to be treated as having distributed, rather than lumped characteristics, by using a grid spacing of $\Delta x = 2.36$ mm with nodes at the center of the individual circuit board or plate. Second, rather than bringing the platens to 190°C in one sudden change, the heating schedule $T_p(t)$ shown below is to be used in order to minimize excessive thermal stresses induced by rapidly changing thermal gradients in the vicinity of the platens.

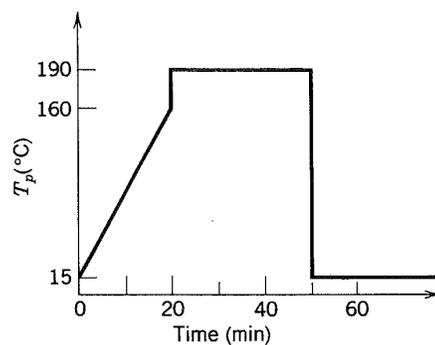

de. What is

the surface convection (T_∞, h).

in terms of

convection change or node?

($\epsilon_s, \epsilon = 0.9$), used to large temperature increment at the surface

ing, the walls the implicit, temperature of gases.

1.5×10^{-6} ical heating estimate the temperatures to a computer

as analyzed used to heat ing situation

- (a) Using a time increment of $\Delta t = 60$ s and the implicit method, find the temperature history of the midplane of the book and determine whether curing will occur (170°C for 5 min).
- (b) Following the reduction of the platen temperatures to 15°C ($t = 50$ min), how long will it take for the midplane of the book to reach 37°C , a safe temperature at which the operator can begin unloading the press?
- (c) Validate your program code by using the heating schedule of a sudden change of platen temperature from 15 to 190°C and compare results with those from an appropriate Heisler solution (see Problem 5.33).
- 5.89 Consider the thermal conduction module and operating conditions of Problem 4.71. To evaluate the transient response of the cold plate, which has a thermal diffusivity of $\alpha = 75 \times 10^{-6} \text{ m}^2/\text{s}$, assume that, when the module is activated at $t = 0$, the initial temperature of the cold plate is $T_i = 15^\circ\text{C}$ and a uniform heat flux of $q''_o = 10^5 \text{ W/m}^2$ is applied at its base. Using the implicit finite-difference method and a time increment of $\Delta t = 0.1$ s, compute the designated nodal temperatures as a function of time. From the temperatures computed at a particular time, evaluate the ratio of the rate of heat transfer by convection to the water to the heat input at the base. Terminate the calculations when this ratio reaches 0.99. Print the temperature field at 5-s intervals and at the time for which the calculations are terminated.

LIBRARY OF CONGRESS



0002080872A



ISBN 0-471-61246-4