

**TRANSMITTAL LETTER TO THE UNITED STATES
DESIGNATED/ELECTED OFFICE (DO/EO/US)
CONCERNING A SUBMISSION UNDER 35 U.S.C. 371**

863.0156.U1(US)

U.S. APPLICATION NO. (If known, see 37 CFR 1.5)

INTERNATIONAL APPLICATION NO.
PCT/FI2008/050384

INTERNATIONAL FILING DATE
23 June 2008

PRIORITY DATE CLAIMED
20 June 2007

TITLE OF INVENTION

Power Headroom Reporting Method

APPLICANT(S) FOR DO/EO/US

Juergen MICHEL, Klaus Ingemann PEDERSEN, Claudio ROSA

Applicant herewith submits to the United States Designated/Elected Office (DO/EO/US) the following items and other information:

1. This is a **FIRST** submission of items concerning a submission under 35 U.S.C. 371.
2. This is a **SECOND** or **SUBSEQUENT** submission of items concerning a submission under 35 U.S.C. 371.
3. This is an express request to begin national examination procedures (35 U.S.C. 371(f)). The submission must include items (5), (6), (9) and (25) indicated below.
4. The US has been elected (Article 31).
5. A copy of the International Application as filed (35 U.S.C. 371 (c)(2))
 - a. is attached hereto (required only if not communicated by the International Bureau).
 - b. has been communicated by the International Bureau.
 - c. is not required, as the application was filed in the United States Receiving Office (RO/US).
6. An English language translation of the International Application as filed (35 U.S.C. 371(c)(2)).
 - a. is attached hereto.
 - b. has been previously submitted under 35 U.S.C. 154(d)(4).
7. Amendments to the claims of the International Application under PCT Article 19 (35 U.S.C. 371 (c)(3))
 - a. are attached hereto (required only if not communicated by the International Bureau).
 - b. have been communicated by the International Bureau.
 - c. have not been made; however, the time limit for making such amendments has NOT expired.
 - d. have not been made and will not be made.
8. An English language translation of the amendments to the claims under PCT Article 19 (35 U.S.C. 371(c)(3)).
9. An oath or declaration of the inventor(s) (35 U.S.C. 371 (c)(4)).
10. An English language translation of the annexes to the International Preliminary Examination Report under PCT Article 36 (35 U.S.C. 371 (c)(5)).
11. A copy of the International Preliminary Examination Report (PCT/IPEA/409).
12. A copy of the International Search Report (PCT/ISA/210).

Items 13 to 23 below concern document(s) or information included:

13. An Information Disclosure Statement under 37 CFR 1.97 and 1.98.
14. An assignment document for recording. A separate cover sheet in compliance with 37 CFR 3.28 and 3.31 is included.
15. A **FIRST** preliminary amendment.
16. A **SECOND** or **SUBSEQUENT** preliminary amendment.
17. An Application Data Sheet under 37 CFR 1.76.
18. A substitute specification.
19. A power of attorney and/or change of address letter.
20. A computer-readable form of the sequence listing in accordance with PCT Rule 13ter.2 and 37 CFR 1.821 - 1.825.
21. A second copy of the published International Application under 35 U.S.C. 154(d)(4).
22. A second copy of the English language translation of the International Application under 35 U.S.C. 154(d)(4).
23. Express Mail Label No.

U.S. APPLICATION NO (if known, see 37 CFR 1.5)	INTERNATIONAL APPLICATION NO. PCT/FI2008/050384	ATTORNEY'S DOCKET NUMBER 863.0156.U1(US)
24. Other items or information:		
The following fees have been submitted:		CALCULATIONS PTO USE
25. <input checked="" type="checkbox"/> Basic national fee (37 CFR 1.492(a)).....	\$330	\$ \$330.00
26. <input checked="" type="checkbox"/> Examination fee (37 CFR 1.492(c)) If the written opinion prepared by ISA/US or the international preliminary examination report prepared by IPEA/US indicates all claims satisfy provisions of PCT Article	\$0	\$ \$220.00
All other situations.....	\$220	
27. <input checked="" type="checkbox"/> Search fee (37 CFR 1.492(b)) If the written opinion of the ISA/US or the International preliminary examination report prepared by IPEA/US indicates all claims satisfy provisions of PCT Article 33(1)-(4)...	\$0	\$ \$430.00
Search fee (37 CFR 1.445(a)(2)) has been paid on the international application to the USPTO as an International Searching Authority.....	\$100	
International Search Report prepared by an ISA other than the US and provided to the Office or previously communicated to the US by the IB.....	\$430	
All other situations.....	\$540	
TOTAL OF 25, 26 and 27 =		\$ \$980.00
<input type="checkbox"/> Additional fee for specification and drawings filed in paper over 100 sheets (excluding sequence listing in compliance with 37 CFR 1.821(c) or (e) in an electronic medium or computer program listing in an electronic medium) (37 CFR 1.492(j)). The fee is \$270 for each additional 50 sheets of paper or fraction thereof.		
Total Sheets	Extra Sheets	Number of each additional 50 or fraction thereof (round up to a whole)
- 100 =	0 /50 =	0
		x \$270.00
		\$ \$0.00
Surcharge of \$130.00 for furnishing any of the search fee, examination fee, or the oath or declaration after the date of commencement of the national stage (37 CFR 1.492(h)).		
		\$
CLAIMS	NUMBER FILED	NUMBER EXTRA
Total claims	39 - 20 =	19
		x \$52.00
		\$ \$988.00
Independent claims	6 - 3 =	3
		x \$220.00
		\$ \$660.00
MULTIPLE DEPENDENT CLAIMS (if applicable) <input type="checkbox"/>		+ \$390.00
		\$ \$0.00
TOTAL OF ABOVE CALCULATIONS =		\$ \$2,628.00
<input type="checkbox"/> Applicant claims small entity status. See 37 CFR 1.27. Fees above are reduced by 1/2.		
		\$ \$0.00
SUBTOTAL =		\$ \$2,628.00
Processing fee of \$130.00 for furnishing the English translation later than 30 months from the earliest claimed priority date (37 CFR 1.492(i)).		
		\$ \$0.00
TOTAL NATIONAL FEE =		\$ \$2,628.00
Fee for recording the enclosed assignment (37 CFR 1.21(h)). The assignment must be accompanied by an appropriate cover sheet (37 CFR 3.28, 3.31). \$40 per property +		
		\$ \$0.00
TOTAL FEES ENCLOSED =		\$ \$2,628.00
		Amount to be \$
		Amount to be \$

Under the Paperwork Reduction Act of 1995, no persons are required to respond to a collection of information unless it displays a valid OMB control number.

- a. A check in the amount of \$ _____ to cover the above fees is enclosed.
- b. Please charge my Deposit Account No. 50-1924 in the amount of \$ \$2,628.00 to cover the above fees. A duplicate copy of this sheet is enclosed.
- c. The Commissioner is hereby authorized to charge any additional fees which may be required, or credit any overpayment to Deposit Account No. 50-1924. A duplicate copy of this sheet is enclosed.
- d. Fees are to be charged to a credit card. **WARNING:** Information on this form may become public. **Credit card information should not be included on this form.** Provide credit card information and authorization on PTO-2038. The PTO-2038 should only be mailed or faxed to the USPTO. However, when paying the basic national fee, the PTO-2038 may NOT be faxed to the USPTO.

ADVISORY: If filing by EFS-Web, do **NOT** attach the PTO-2038 form as a PDF along with your EFS-Web submission. Please be advised that this is **not** recommended and by doing so your **credit card information may be displayed via PAIR**. To

NOTE: Where an appropriate time limit under 37 CFR 1.495 has not been met, a petition to revive (37 CFR 1.137(a) or (b)) must be filed and granted to restore the International Application to pending status.

SEND ALL CORRESPONDENCE TO:

Customer No. 29683
Harrington & Smith, PC
4 Research Drive
Shelton, CT 06484-6212

SIGNATURE

Harry F. Smith
NAME

32,493
REGISTRATION NUMBER

December 18, 2009
DATE

IN THE U.S. PATENT AND TRADEMARK OFFICE

In re U.S. Patent Application of:

APPLICANTS: Michel et al.
SERIAL NO.: to be assigned
FILING DATE: Herewith
EXAMINER:
ART UNIT:

DOCKET NO.: 863.0156.U1(US)

TITLE: Power Headroom Reporting Method

COMMISSIONER FOR PATENTS
P.O. Box 1450
Alexandria, VA 22313-1450

PRELIMINARY AMENDMENT

Sir:

This Preliminary Amendment is herewith filed in conjunction with the filing of a new U.S. Patent Application. Please charge Deposit Account No. 50-1924 for the fees required as a result of this preliminary amendment.

Please amend the application as shown below.

In the Claims

This listing of the claims will replace all prior versions, and listings, of the claims in this application.

1. (Currently Amended) A method (~~300~~) comprising: determining (~~315~~) that a set of at least one triggering criterion is met; and providing (~~325~~) a power control headroom report on an uplink from user equipment, in response to determining that the set is met, wherein said at least one triggering criterion include a threshold having been reached.
2. (Original) The method of claim 1, wherein said threshold is adjustable via a signal to the user equipment.
3. (Original) The method of claim 1, wherein the set comprises a criterion such that an absolute difference between current and most recent path-loss measurements has reached a threshold of difference.
4. (Original) The method of claim 1, wherein said set of at least one triggering criterion include any one of a plurality of criteria that each entail Teaching a respective threshold.
5. (Original) The method of claim 4, wherein the plurality of criteria comprise a first criterion, a second criterion, and a third criterion.
6. (Original) The method of claim 1, wherein the set comprises a criterion such that a number of received closed loop power corrections has reached a threshold of corrections.
7. (Original) The method of claim 1, wherein the set comprises a criterion such that an amount of transmission time intervals, following an open loop power control modification, has reached a threshold of intervals since modification.

8. (Original) The method of claim 1, wherein the set comprises a criterion such that an amount of transmission time intervals, following a previous power control headroom report, has reached a threshold of intervals since reporting.

9. (Original) The method of claim 5, wherein the first criterion is such that a number of received closed loop power corrections has reached a threshold of corrections, and wherein the second criterion is such that an amount of transmission time intervals, following an open loop power control modification, has reached a threshold of intervals since modification.

10. (Original) The method of claim 9, wherein the third criterion is such that an amount of transmission time intervals, following a previous power control headroom report, has reached a threshold of intervals since reporting.

11. (Original) The method of claim 9, wherein the third criterion is such that an absolute difference between current and most recent path-loss measurements has reached a threshold of difference.

12. (Original) An apparatus (405) comprising: means (413) for determining that a set of at least one triggering criterion is met; and means (414) for providing a power control headroom report on an uplink from user equipment, in response to the set having been met, wherein said at least one triggering criterion include a threshold having been reached.

13. (Original) The apparatus of claim 12, wherein said threshold is adjustable via a signal to the user equipment.

14. (Original) The apparatus of claim 12, wherein the set comprises a criterion such that an absolute difference between current and most recent path-loss measurements has reached a threshold of difference.

15. (Original) The apparatus of claim 12, wherein said set of at least one triggering criterion include any one of a plurality of criteria that each entail reaching a respective threshold.
16. (Original) The apparatus of claim 15, wherein the plurality of criteria comprise a first criterion, a second criterion, and a third criterion.
17. (Original) The apparatus of claim 16, wherein the first criterion is such that a number of received closed loop power corrections has reached a threshold of corrections, and wherein the second criterion is such that an amount of transmission time intervals, following an open loop power control modification, has reached a threshold of intervals since modification.
18. (Original) The apparatus of claim 17, wherein the third criterion is such that an amount of transmission time intervals, following a previous power control headroom report, has reached a threshold of intervals since reporting.
19. (Original) The apparatus of claim 17, wherein the third criterion is such that an absolute difference between current and most recent path-loss measurements has reached a threshold of difference.
20. (Currently Amended) Apparatus (405) comprising: a triggering module (413) configured to determine that a set of at least one triggering criterion is met; and a transceiver (414) configured to provide a power control headroom report on an uplink from said user equipment, in response to the set having been met, wherein said at least one triggering criterion include a threshold having been reached.
21. (Original) The apparatus of claim 20, wherein said threshold is adjustable via a signal to the apparatus.

22. (Original) The apparatus of claim 20, wherein the set comprises a criterion such that an absolute difference between current and most recent path-loss measurements has reached a threshold of difference.

23. (Original) The apparatus of claim 20, wherein said set of at least one triggering criterion include any one of a plurality of criteria that each entail reaching a respective threshold.

24. (Original) The apparatus of claim 23, wherein the plurality of criteria comprise a first criterion, a second criterion, and a third criterion.

25. (Original) The apparatus of claim 24, wherein the first criterion is such that a number of received closed loop power corrections has reached a threshold of corrections, and wherein the second criterion is such that an amount of transmission time intervals, following an open loop power control modification, has reached a threshold of intervals since modification.

26. (Original) The apparatus of claim 24, wherein the third criterion is such that an amount of transmission time intervals, following a previous power control headroom report, has reached a threshold of intervals since reporting.

27. (Original) The apparatus of claim 24, wherein the third criterion is such that an absolute difference between current and most recent path-loss measurements has reached a threshold of difference.

28. (Currently Amended) A computer program product comprising a computer readable medium having executable code stored therein; the code, when executed by a processor, adapted to carry out the functions of: determining ~~(315)~~ that a set of at least one triggering criterion is met; and providing ~~(325)~~ a power control headroom report on an uplink from user equipment, in response to the set having been met, wherein said at least one triggering criterion include a threshold having been reached.

29. (Original) The computer program product of claim 28, wherein said threshold is adjustable via a signal to the user equipment.
30. (Original) The computer program product of claim 28, wherein the set comprises a criterion such that an absolute difference between current and most recent path-loss measurements has reached a threshold of difference.
31. (Original) The computer program product of claim 28, wherein said set of at least one triggering criterion include any one of a plurality of criteria that each entail reaching a respective threshold.
32. (Original) The computer program product of claim 31, wherein the plurality of criteria comprise a first criterion, a second criterion, and a third criterion.
33. (Original) The computer program product of claim 32, wherein the first criterion is such that a number of received closed loop power corrections has reached a threshold of corrections, and wherein the second criterion is such that an amount of transmission time intervals, following an open loop power control modification, has reached a threshold of intervals since modification.
34. (Currently Amended) A network element (492) comprising: a report receiving module (463) configured to receive a power control headroom report on an uplink from user equipment, in response to the user equipment determining that a set of at least one triggering criterion is met because a threshold has been reached, and a threshold adjustment module (468), configured to provide a threshold adjustment signal to the user equipment in order to adjust the threshold.
35. (Original) The network element of claim 34, wherein the set comprises a criterion such that an absolute difference between current and most recent path-loss measurements has reached a threshold of difference.

36. (Original) The network element of claim 34, further comprising a correction module configured to provide a closed loop power control correction command signal to the user equipment at least partly in response to said power control headroom report.

37. (Currently Amended) A system (400) comprising:
user equipment (405) having a triggering module (413) configured to determine that a set of at least one triggering criterion is met, and having a transceiver (411) configured to provide a power control headroom report on an uplink from said user equipment, in response to the set having been met, wherein said at least one triggering criterion include a threshold having been reached; and
a network element (492) having a report receiving module (463) configured to receive a power control headroom report on an uplink from user equipment, in response to the user equipment determining that a set of at least one triggering criterion is met because said threshold has been reached, and having a threshold adjustment module (468) configured to provide a threshold adjustment signal to the user equipment in order to adjust the threshold.

38. (Original) The system of claim 37, wherein the set comprises a criterion such that an absolute difference between current and most recent path-loss measurements has reached a threshold of difference.

39. (Original) The system of claim 37, wherein the set comprises a first criterion, a second criterion, and a third criterion, wherein the first criterion is such that a number of received closed loop power corrections has reached a threshold of corrections, and wherein the second criterion is such that an amount of transmission time intervals, following an open loop power control modification, has reached a threshold of intervals since modification.

REMARKS

This amendment removes the reference designators from the claims. The amendment was not made for reasons related to patentability, and the full range of equivalents for all of the elements of the amended claims, as well as for all of the other claims, should remain intact.

A favorable consideration that results in the allowance of all of the pending claims is earnestly solicited.

Respectfully submitted:



Harry F. Smith

Reg. No.: 31,686
Customer No.: 29683
HARRINGTON & SMITH, PC
4 Research Drive
Shelton, CT 06484-6212
Telephone: (203) 925-9400
Facsimile: (203) 944-0245

December 18, 2009
Date

IN THE UNITED STATES PATENT AND TRADEMARK OFFICE

Application No.: to be assigned Confirmation No.:
Applicant(s): Michel et al.
Filed: herewith
Art Unit:
Examiner:

Title: Power Headroom Reporting Method

Attorney Docket No.: 863.0156.U1(US)

Commissioner For Patents
P.O. Box 1450
Alexandria, VA 22313-1450

Information Disclosure Statement
(37 C.F.R. §1.97(b))

Sir:

The following information is being disclosed to the U.S. Patent and Trademark Office as information that may be material to the examination of the above-identified patent application.

Applicant's Attorney is aware of the documents listed on the enclosed Form PTO-1449. Copies of the non-US documents are enclosed with the Form PTO-1449 for the Examiner's use. The documents listed were cited in an International Search Report issued in the parent International application. A copy of the Search Report is attached.

The filing of this Statement is not to be construed as a representation that a search has been made regarding the claimed invention (37 C.F.R. §1.97(g)) or that no other possible

material information exists. In addition, the filing of this Statement is not to be construed to be an admission that the information cited in the Statement is, or is considered to be, material to Patentability (37 C.F.R. §1.97(h)).

Respectfully submitted,



Harry F. Smith (Reg. No. 32,493)
Customer No.: 29683
Harrington & Smith, PC
4 Research Drive
Shelton, CT 06484-6212
203-925-9400

December 18, 2009

Date

INFORMATION DISCLOSURE CITATION FORM FOR PATENT APPLICATION (FORM PTO-1449) (Substitute)		Docket No.: 863.0156.U1(US) Applicant(s): Michel et al. Filing Date: herewith	Serial No.: to be assigned Group: N/A		
U.S. PATENT DOCUMENTS					
Examiner Initials	Document Number (Number-Kind Code)	Publication Date (MM-DD-YYYY)	Name of Patentee or Applicant	Class	Sub-class
	US-2003/0026324 A1 US- US- US- US- US- US- US- US- US- US- US- US-	02-06-2003	Li et al.		
FOREIGN PATENT DOCUMENTS					
Examiner Initials	Document Number (Country Code-Number-Kind Code)	Publication Date (MM-DD-YYYY)	Name Of Patentee of Applicant	Translation? Yes/No/n/a	
	EP 1 311 076 A1 EP 1 628 413 A2 WO 00/03499 WO 00/62441 - - - - - -	05-14-2003 02-22-2006 01-20-2000 10-19-2000	Lucent Technologies Inc. Samsung Electronics Co., Ltd. Samsung Electronics Co., Ltd. Telefonaktiebolaget LM Ericsson		
OTHER DOCUMENTS (Author (Capitalize), Title, Date, Pages, Etc., if known)					
Examiner's Signature:			Date Considered:		
Initial if reference was considered, whether or not citation is in conformance with MPEP. Mark through citation if not considered. Include a copy of this citation form with your next correspondence to the Applicant(s).					

PATENT COOPERATION TREATY

PCT

INTERNATIONAL SEARCH REPORT

(PCT Article 18 and Rules 43 and 44)

Applicant's or agent's file reference 2081086PC/nu	FOR FURTHER ACTION		see Form PCT/ISA/220 as well as, where applicable, item 5 below.
International application No. PCT/FI2008/050384	International filing date (<i>day/month/year</i>) 23 June 2008 (23.06.2008)	(Earliest) Priority Date (<i>day/month/year</i>) 20 June 2007 (20.06.2007)	
Applicant NOKIA SIEMENS NETWORKS OY et al.			

This international search report has been prepared by this International Searching Authority and is transmitted to the applicant according to Article 18. A copy is being transmitted to the International Bureau.

This international search report consists of a total of 4 sheets.

It is also accompanied by a copy of each prior art document cited in this report.

1. **Basis of the report**

a. With regard to the **language**, the international search was carried out on the basis of:

the international application in the language in which it was filed.

a translation of the international application into _____ which is the language of a translation furnished for the purposes of international search (Rules 12.3(a) and 23.1(b)).

b. This international search report has been established taking into account the **rectification of an obvious mistake** authorized by or notified to this Authority under Rule 91 (Rule 43.6bis(a)).

c. With regard to any **nucleotide and/or amino acid sequence** disclosed in the international application, see Box No. I.

2. **Certain claims were found unsearchable** (see Box No. II).

3. **Unity of invention is lacking** (see Box No. III).

4. With regard to the **title**,

the text is approved as submitted by the applicant.

the text has been established by this Authority to read as follows:

5. With regard to the **abstract**,

the text is approved as submitted by the applicant.

the text has been established, according to Rule 38.2, by this Authority as it appears in Box No. IV. The applicant may, within one month from the date of mailing of this international search report, submit comments to this Authority.

6. With regard to the **drawings**,

a. the figure of the **drawings** to be published with the abstract is Figure No. 3

as suggested by the applicant.

as selected by this Authority, because the applicant failed to suggest a figure.

as selected by this Authority, because this figure better characterizes the invention.

b. none of the figures is to be published with the abstract.

INTERNATIONAL SEARCH REPORT

International application No.

PCT/FI2008/050384

A. CLASSIFICATION OF SUBJECT MATTER See extra sheet According to International Patent Classification (IPC) or to both national classification and IPC		
B. FIELDS SEARCHED Minimum documentation searched (classification system followed by classification symbols) IPC8: H04B Documentation searched other than minimum documentation to the extent that such documents are included in the fields searched FI, SE, NO, DK Electronic data base consulted during the international search (name of data base and, where practicable, search terms used) EPO-internal, WPI, XPIEE, XPI3E		
C. DOCUMENTS CONSIDERED TO BE RELEVANT		
Category*	Citation of document, with indication, where appropriate, of the relevant passages	Relevant to claim No.
A	WO 0003499 A1 (SAMSUNG ELECTRONICS CO LTD) 20 January 2000 (20.01.2000), abstract; page 4, lines 1-24; claim 1	1-39
A	EP 1628413 A2 (SAMSUNG ELECTRONICS CO LTD) 22 February 2006 (22.02.2006), abstract; paragraphs [0034] – [0043]	1-39
A	US 2003026324 A1 (LI D. et al.) 06 February 2003 (06.02.2003), abstract; paragraphs [0011] – [0021]	1-39
A	EP 1311076 A1 (LUCENT TECHNOLOGIES INC) 14 May 2003 (14.05.2003), abstract; paragraphs [0014] – [0025]	1-39
A	WO 0062441 A1 (ERICSSON TELEFON AB L M) 19 October 2000 (19.10.2000), abstract; page 8, lines 1-28; page 9, lines 1-22	1-39
<input type="checkbox"/> Further documents are listed in the continuation of Box C. <input checked="" type="checkbox"/> See patent family annex.		
* Special categories of cited documents: "A" document defining the general state of the art which is not considered to be of particular relevance "E" earlier application or patent but published on or after the international filing date "L" document which may throw doubts on priority claim(s) or which is cited to establish the publication date of another citation or other special reason (as specified) "O" document referring to an oral disclosure, use, exhibition or other means "P" document published prior to the international filing date but later than the priority date claimed "T" later document published after the international filing date or priority date and not in conflict with the application but cited to understand the principle or theory underlying the invention "X" document of particular relevance; the claimed invention cannot be considered novel or cannot be considered to involve an inventive step when the document is taken alone "Y" document of particular relevance; the claimed invention cannot be considered to involve an inventive step when the document is combined with one or more other such documents, such combination being obvious to a person skilled in the art "&" document member of the same patent family		
Date of the actual completion of the international search 21 October 2008 (21.10.2008)		Date of mailing of the international search report 27 October 2008 (27.10.2008)
Name and mailing address of the ISA/FI National Board of Patents and Registration of Finland P.O. Box 1160, FI-00101 HELSINKI, Finland Facsimile No. +358 9 6939 5328		Authorized officer Pasi Suvikunnas Telephone No. +358 9 6939 500

Form PCT/ISA/210 (second sheet) (July 2008)

INTERNATIONAL SEARCH REPORT
Information on patent family members

International application No.
PCT/FI2008/050384

Patent document cited in search report	Publication date	Patent family members(s)	Publication date
WO 0003499 A1	20/01/2000	US 6512931 B1	28/01/2003
		RU 2187893 C2	20/08/2002
		EP 1013006 A1	28/06/2000
		CN 1272987 A	08/11/2000
		CA 2299575 A1	20/01/2000
		BR 9906825 A	15/08/2000
		AU 4656899 A	01/02/2000
EP 1628413 A2	22/02/2006	HR 20070049 A2	31/08/2007
		BR PI0514446 A	10/06/2008
		JP 2008511201T T	10/04/2008
		CN 101044700 A	26/09/2007
		CA 2576383 A1	23/02/2006
		AU 2005273089 A1	23/02/2006
		KR 20060017314 A	23/02/2006
		US 2006040619 A1	23/02/2006
WO 2006019287 A1	23/02/2006		
US 2003026324 A1	06/02/2003	US 2005254467 A1	17/11/2005
		WO 02069525 A1	06/09/2002
EP 1311076 A1	14/05/2003	DE 60127138T T2	22/11/2007
		US 2003092463 A1	15/05/2003
WO 0062441 A1	19/10/2000	AT 410835T T	15/10/2008
		TW 462155B B	01/11/2001
		JP 2002542655T T	10/12/2002
		EP 1169785 A1	09/01/2002
		CN 1355964 A	26/06/2002
		CA 2369918 A1	19/10/2000
		AU 4161500 A	14/11/2000
		US 6334047 B1	25/12/2001

INTERNATIONAL SEARCH REPORT

International application No.
PCT/FI2008/050384

CLASSIFICATION OF SUBJECT MATTER

Int.Cl.
H04B 7/005 (2006.01)

Form PCT/ISA/210 (extra sheet) (July 2008)

PATENT COOPERATION TREATY

From the
INTERNATIONAL SEARCHING AUTHORITY

PCT

WRITTEN OPINION OF THE
INTERNATIONAL SEARCHING AUTHORITY

(PCT Rule 43*bis*.1)

To:
KOLSTER OY AB
P.O. Box 148 Iso Roobertinkatu 23
FI-00121 Helsinki
FINLAND

Date of mailing (*day/month/year*)
27 October 2008 (27.10.2008)

Applicant's or agent's file reference 2081086PC/nu	FOR FURTHER ACTION See paragraph 2 below
-------------------------------------------------------	----------------------------------------------------

International application No. PCT/FI2008/050384	International filing date (<i>day/month/year</i>) 23 June 2008 (23.06.2008)	Priority date (<i>day/month/year</i>) 20 June 2007 (20.06.2007)
----------------------------------------------------	----------------------------------------------------------------------------------	----------------------------------------------------------------------

International Patent Classification (IPC) or both national classification and IPC
See supplemental box

Applicant
NOKIA SIEMENS NETWORKS OY et al.

1. This opinion contains indications relating to the following items:

- Box No. I Basis of the opinion
- Box No. II Priority
- Box No. III Non-establishment of opinion with regard to novelty, inventive step and industrial applicability
- Box No. IV Lack of unity of invention
- Box No. V Reasoned statement under Rule 43*bis*.1(a)(i) with regard to novelty, inventive step or industrial applicability; citations and explanations supporting such statement
- Box No. VI Certain documents cited
- Box No. VII Certain defects in the international application
- Box No. VIII Certain observations on the international application

2. **FURTHER ACTION**

If a demand for international preliminary examination is made, this opinion will be considered to be a written opinion of the International Preliminary Examining Authority ("IPEA") except that this does not apply where the applicant chooses an Authority other than this one to be the IPEA and the chosen IPEA has notified the International Bureau under Rule 66.1*bis*(b) that written opinions of this International Searching Authority will not be so considered.

If this opinion is, as provided above, considered to be a written opinion of the IPEA, the applicant is invited to submit to the IPEA a written reply together, where appropriate, with amendments, before the expiration of 3 months from the date of mailing of Form PCT/ISA/220 or before the expiration of 22 months from the priority date, whichever expires later.

For further options, see Form PCT/ISA/220.

3. For further details, see notes to Form PCT/ISA/220.

Name and mailing address of the ISA/FI National Board of Patents and Registration of Finland P.O. Box 1160, FI-00101 HELSINKI, Finland Facsimile No. +358 9 6939 5328	Date of completion of this opinion 21 October 2008 (21.10.2008)	Authorized officer Pasi Suvikunnas Telephone No. +358 9 6939 500
--------------------------------------------------------------------------------------------------------------------------------------------------------------------------------	--------------------------------------------------------------------	------------------------------------------------------------------------

Form PCT/ISA/237 (cover sheet) (April 2007)

WRITTEN OPINION OF THE
INTERNATIONAL SEARCHING AUTHORITY

International application No.
PCT/FI2008/050384

Box No. 1 Basis of this opinion

1. With regard to the **language**, this opinion has been established on the basis of:
 - the international application in the language in which it was filed.
 - a translation of the international application into _____ which is the language of a translation furnished for the purposes of international search (Rules 12.3(a) and 23.1(b)).
2. This opinion has been established taking into account the **rectification of an obvious mistake** authorized by or notified to this Authority under Rule 91 (Rule 43*bis*.1(a))
3. With regard to any **nucleotide and/or amino acid sequence** disclosed in the international application, this opinion has been established on the basis of:
 - a. type of material
 - a sequence listing
 - table(s) related to the sequence listing
 - b. format of material
 - on paper
 - in electronic form
 - c. time of filing/furnishing
 - contained in the international application as filed
 - filed together with the international application in electronic form
 - furnished subsequently to this Authority for the purposes of search
4. In addition, in the case that more than one version or copy of a sequence listing and/or table(s) relating thereto has been filed or furnished, the required statements that the information in the subsequent or additional copies is identical to that in the application as filed or does not go beyond the application as filed, as appropriate, were furnished.
5. Additional comments:

WRITTEN OPINION OF THE
INTERNATIONAL SEARCHING AUTHORITY

International application No.
PCT/FI2008/050384

Box No. V Reasoned statement under Rule 43bis.1(a)(i) with regard to novelty, inventive step or industrial applicability; citations and explanations supporting such statement

1. Statement

Novelty (N)	Claims <u>1-39</u>	YES
	Claims _____	NO
Inventive step (IS)	Claims <u>1-39</u>	YES
	Claims _____	NO
Industrial applicability (IA)	Claims <u>1-39</u>	YES
	Claims _____	NO

2. Citations and explanations:

2.1 Documents cited in the International Search Report

D1: WO0003499A1
D2: EP1628413A2
D3: US2003026324A1
D4: EP1311076A1
D5: WO0062441A1

2.2 Claimed invention

The claimed invention relates to a method and an apparatus with means for determining that a set of at least one triggering criterion is met; and providing a power control headroom report on an uplink from a user equipment, in response to determining that the set is met, wherein said at least one triggering criterion include a threshold having been reached. The claimed invention also relates to a triggering module, a transceiver, and a computer program product comprising a computer readable medium having executable code stored therein. Further, the claimed invention relates to a network element comprising a report receiving module and a system comprising a user equipment.

2.3 Novelty under PCT Article 33(2)

Documents D1-D5 represent the general state of the art.

Document D1 (abstract; page 4, lines 1-24; claim 1) discloses a power control device and method for reducing the excessive signal power of a reverse common channel in a code division multiple access (CDMA) mobile communication system. Moreover, D1 discloses a device and method for controlling the transmission power of a reverse common channel using both an open-loop power control (OLPC) and a closed-loop power control (CLPC). The mobile station (MS) transmits a preamble signal at predetermined intervals, increasing the transmission power each time, until receipt of an acknowledge signal from a base station (BS). The method comprises the steps of: accumulating power control signals received for a predetermined time over a forward common channel to generate an accumulated value; comparing the accumulated value with a threshold; if the accumulated value is less than the threshold the transmission power is decreased; if the accumulated value is greater than the threshold the present transmission power is maintained.

Document D2 (abstract; paragraphs [0034] – [0043]) discloses an apparatus and method for changing an uplink power control scheme according to mobile velocity in a time division duplex (TDD) mobile communication system. A MS transmits to a BS a power control change request message including information about a requested power control scheme. The BS selects a power control scheme for the

Continued to next page

Supplemental Box

Continuation of: Box V (1 / 1)

uplink and transmits to the MS a power control change command message including information about the selected power control scheme.

Document D3 (abstract; paragraphs [0011] – [0021]) discloses a power-controlled random-access method for a MS to gain fast access to a BS in a CDMA system. At the MS, a composite power control command is devised after an initial access attempt. The determination of the composite command uses an OLPC symbol and a CLPC symbol, to decide the action of the MS upon transmission of its next random-access signal. The composite power control command can specify different levels of increase or decrease in transmission power and can specify a back-off by the MS.

Document D4 (abstract; paragraphs [0014] – [0025]) discloses a method and apparatuses for controlling the transmission power in the uplink direction of a CDMA-based radio system. The CDMA-based radio system comprises an inner power control loop (IPCL) adjusting the transmission power between a MS and BS based on the signal to interference ratio (SNR). It also comprises an outer power control loop (OPCL) for adjusting target signal to interference ratio (SINR) based on the link quality (block error rate) to ensure a target link quality necessary for fulfilling a predetermined link quality at least within a predefined range. The OPCL is based on a combination of a first OPCL established between at least one BS and MS and of a second OPCL established between an associated serving radio control means and the at least one BS.

Document D5 (abstract; page 8, lines 1-28; page 9, lines 1-22) discloses a power control method in a mobile communication system. In the method the value of a signal parameter detected from a signal received by a radio transceiver is compared with a desired signal parameter value, and a difference is determined. Included with the transmit power control command is a power control indicator indicating whether a first or a second type of power control adjustment should be used by the radio transceiver depending upon the determined difference. Because only the indicator is sent (and not the details), signalling overhead and bandwidth consumption related to frequently sent power control commands are kept to a minimum.

None of the documents discloses all the features of claims 1, 12, 20, 28, 34 and 37. The subject matter of claims 1, 12, 20, 28, 34 and 37 is therefore novel. Because the subject matter of independent claims 1, 12, 20, 28, 34 and 37 is novel, dependent claims 2-11, 13-19, 21-27, 29-33, 35-36 and 38-39 are also novel.

2.4 Inventive step under PCT Article 33(3)

None of the documents D1-D5 relates to a method and an apparatus with means for determining that a set of at least one triggering criterion is met. Nor documents D1-D5 provide a power control headroom report on an uplink from user equipment, in response to determining that the set is met. Consequently, a triggering module, a transceiver, a computer program product comprising a computer readable medium, a network element comprising a report receiving module and a system comprising a user equipment related to the method and the apparatus are not known either.

Hence, the subject matter of claims 1-39 is neither known from nor suggested by the prior art. Consequently, the subject matter of claims 1-39 is considered to meet the requirement of inventive step.

2.5 Industrial applicability under PCT Article 33(4)

Claims 1-39 meet the requirement of industrial applicability because the claimed subject matter can be made or used in industry.

**WRITTEN OPINION OF THE
INTERNATIONAL SEARCHING AUTHORITY**

International application No.
PCT/FI2008/050384

Box No. VII Certain defects in the international application

The following defects in the form or contents of the international application have been noted:

Claims 1-39 are not drafted in the two-part form in accordance with PCT Rule 6.3(b), which in the present case would be appropriate, with those features known from the prior art placed in the preamble (PCT Rule 6.3(b)(i)) and the remaining features included in the characterising part (PCT Rule 6.3(b)(ii)).

WRITTEN OPINION OF THE
INTERNATIONAL SEARCHING AUTHORITY

International application No.
PCT/FI2008/050384

Box No. VIII Certain observations on the international application

The following observations on the clarity of the claims, description, and drawings or on the question whether the claims are fully supported by the description, are made:

Independent claims 1, 12, 20, 34, and 37 do not contain all the features that are essential for describing a method, an apparatus, a network and a system. Consequently, the technical content of a method, an apparatus, a network and a system should be better clarified in the preamble of independent claims 1, 12, 20, 34, and 37. Therefore independent claims 1, 12, 20, 34, and 37 do not meet the requirements of PCT Article 6 in conjunction with PCT Rule 6.3(b) in that each independent claim must include all the technical features essential to the definition of the invention.

The dependent claims 6, 7, and 8 include essentially the same information as dependent claims 9 and 10. The claims therefore lack conciseness and as such do not meet the requirements of PCT Article 6.

WRITTEN OPINION OF THE
INTERNATIONAL SEARCHING AUTHORITY

International application No.
PCT/FI2008/050384

Supplemental Box

In case the space in any of the preceding boxes is not sufficient.
Continuation of: International Patent Classification (IPC)

Int.Cl.
H04B 7/005 (2006.01)

(19) World Intellectual Property Organization
International Bureau



(43) International Publication Date
24 December 2008 (24.12.2008)

PCT

(10) International Publication Number
WO 2008/155469 A1

- (51) International Patent Classification:
H04B 7/005 (2006.01)
- (21) International Application Number:
PCT/FI2008/050384
- (22) International Filing Date: 23 June 2008 (23.06.2008)
- (25) Filing Language: English
- (26) Publication Language: English
- (30) Priority Data:
60/936,649 20 June 2007 (20.06.2007) US
- (71) Applicant (for all designated States except US): **NOKIA SIEMENS NETWORKS OY** [FI/FI]; Karaportti 3, FI-02610 Espoo (FI).

(DE). **PEDERSEN, Klaus Ingemann** [DK/DK]; Laesogade 9, 3 th, DK-9000 Aalborg (DK). **ROSA, Claudio** [IT/DK]; Krebsen 14, DK-8900 Randers (DK).

(74) Agent: **KOLSTER OY AB**; Iso Roobertinkatu 23, P.O. Box 148, FI-00121 Helsinki (FI).

(81) Designated States (unless otherwise indicated, for every kind of national protection available): AE, AG, AL, AM, AO, AT, AU, AZ, BA, BB, BG, BH, BR, BW, BY, BZ, CA, CH, CN, CO, CR, CU, CZ, DE, DK, DM, DO, DZ, EC, EE, EG, ES, FI, GB, GD, GE, GH, GM, GT, HN, HR, HU, ID, IL, IN, IS, JP, KE, KG, KM, KN, KP, KR, KZ, LA, LC, LK, LR, LS, LT, LU, LY, MA, MD, ME, MG, MK, MN, MW, MX, MY, MZ, NA, NG, NI, NO, NZ, OM, PG, PH, PL, PT, RO, RS, RU, SC, SD, SE, SG, SK, SL, SM, SV, SY, TJ, TM, TN, TR, TT, TZ, UA, UG, US, UZ, VC, VN, ZA, ZM, ZW.

- (72) Inventors; and
- (75) Inventors/Applicants (for US only): **MICHEL, Jürgen** [DE/DE]; Sebastian-Bauer-Strasse 35, 81737 München

(84) Designated States (unless otherwise indicated, for every kind of regional protection available): ARIPO (BW, GH, GM, KE, LS, MW, MZ, NA, SD, SL, SZ, TZ, UG, ZM,

[Continued on next page]

(54) Title: POWER HEADROOM REPORTING METHOD

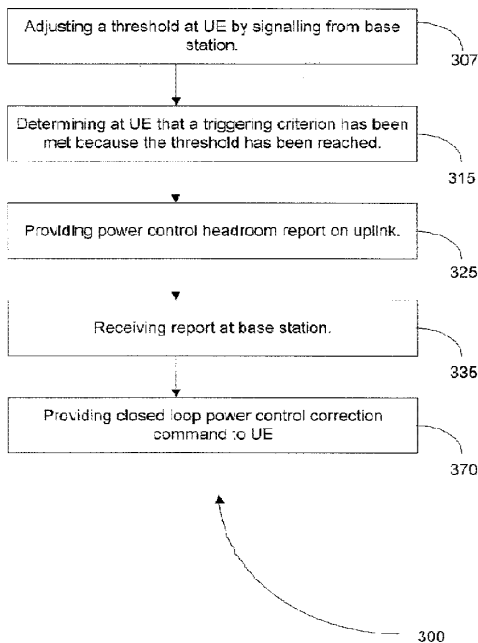

(57) Abstract: A method, user equipment, network device, and software product enable a user equipment to determine that at least one of several triggering criterion have been met, in which case the user equipment provides a power control headroom report on an uplink from the user equipment. The triggering criterion includes a threshold having been reached, and the threshold is adjustable via a signal to the user equipment from a base station (such as an eNodeB).

FIG. 3

WO 2008/155469 A1



ZW), Eurasian (AM, AZ, BY, KG, KZ, MD, RU, TJ, TM),
European (AT, BE, BG, CH, CY, CZ, DE, DK, EE, ES, FI,
FR, GB, GR, HR, HU, IE, IS, IT, LT, LU, LV, MC, MT, NL,
NO, PL, PT, RO, SE, SI, SK, TR), OAPI (BF, BJ, CF, CG,
CI, CM, GA, GN, GQ, GW, ML, MR, NE, SN, TD, TG).

— *before the expiration of the time limit for amending the
claims and to be republished in the event of receipt of
amendments*

— *the filing date of the international application is within two
months from the date of expiration of the priority period*

Published:

— *with international search report*

POWER HEADROOM REPORTING METHOD

Field of the Invention

5 The invention relates to the field of wireless telecommunications. More particularly, the present invention pertains to power control.

Background of the Invention

10 The telecommunications industry is in the process of developing a new generation of flexible and affordable communications that includes high-speed access while also supporting broadband services. Many features of the third generation (3G) mobile telecommunications system have already been established, but many other features have yet to be perfected. The Third Generation Partnership Project (3GPP) has been pivotal in these developments.

15 One of the systems within the third generation of mobile communications is the Universal Mobile Telecommunications System (UMTS) which delivers voice, data, multimedia, and wideband information to stationary as well as mobile customers. UMTS is designed to accommodate increased system capacity and data capability. Efficient use of the electromagnetic spectrum is vital in UMTS. It is known that spectrum efficiency can be attained using frequency division duplex (FDD) or using time division duplex (TDD)
20 schemes. Space division duplex (SDD) is a third duplex transmission method used for wireless telecommunications.

 As can be seen in **FIG. 1**, the UMTS architecture consists of user equipment **102** (UE), the UMTS Terrestrial Radio Access Network **104** (UTRAN), and the Core Network **126** (CN). The air interface between the UTRAN and the UE is called Uu, and the interface
25 between the UTRAN and the Core Network is called Iu.

 High-Speed Downlink Packet Access (HSDPA) and High-Speed Uplink Packet Access (HSUPA) are further 3G mobile telephony protocols in the High-Speed Packet Access (HSPA) family. They provide a smooth evolutionary path for UMTS-based networks allowing for higher data transfer speeds.

Evolved UTRAN (EUTRAN) is a more recent project than HSPA, and is meant to take 3G even farther into the future. EUTRAN is designed to improve the UMTS mobile phone standard in order to cope with various anticipated requirements. EUTRAN is frequently indicated by the term Long Term Evolution (LTE), and is also associated with terms like System Architecture Evolution (SAE). One target of EUTRAN is to enable all internet protocol (IP) systems to efficiently transmit IP data. The system will have only use a PS (packet switched) domain for voice and data calls, i.e. the system will contain Voice Over Internet Protocol (VoIP).

Information about LTE can be found in 3GPP TS 36.300 (V8.0.0, March 2007), *Evolved Universal Terrestrial Radio Access (E-UTRA) and Evolved Universal Terrestrial Radio Access Network (E-UTRAN) – Overall description; Stage 2 (Release 8)*, which is incorporated herein by reference in its entirety. UTRAN and EUTRAN will now be described in some further detail, although it is to be understood that especially E-UTRAN is evolving over time.

The UTRAN consists of a set of Radio Network Subsystems **128** (RNS), each of which has geographic coverage of a number of cells **110** (C), as can be seen in FIG. 1. The interface between the subsystems is called Iur. Each Radio Network Subsystem **128** (RNS) includes a Radio Network Controller **112** (RNC) and at least one Node B **114**, each Node B having geographic coverage of at least one cell **110**. As can be seen from Figure 1, the interface between an RNC **112** and a Node B **114** is called Iub, and the Iub is hard-wired rather than being an air interface. For any Node B **114** there is only one RNC **112**. A Node B **114** is responsible for radio transmission and reception to and from the UE **102** (Node B antennas can typically be seen atop towers or preferably at less visible locations). The RNC **112** has overall control of the logical resources of each Node B **114** within the RNS **128**, and the RNC **112** is also responsible for handover decisions which entail switching a call from one cell to another or between radio channels in the same cell.

In UMTS radio networks, a UE can support multiple applications of different qualities of service running simultaneously. In the MAC layer, multiple logical channels can be

5 multiplexed to a single transport channel. The transport channel can define how traffic from logical channels is processed and sent to the physical layer. The basic data unit exchanged between MAC and physical layer is called the Transport Block (TB). It is composed of an RLC PDU and a MAC header. During a period of time called the transmission time interval (TTI), several transport blocks and some other parameters are delivered to the physical layer.

Generally speaking, a prefix of the letter "E" in upper or lower case signifies the Long Term Evolution (LTE). The E-UTRAN consists of eNBs (E-UTRAN Node B), providing the E-UTRA user plane (RLC/MAC/PHY) and control plane (RRC) protocol terminations towards the UE. The eNBs interface to the access gateway (aGW) via the S1, and are inter-
10 connected via the X2.

An example of the E-UTRAN architecture is illustrated in FIG. 2. This example of E-UTRAN consists of eNBs, providing the E-UTRA user plane (RLC/MAC/PHY) and control plane (RRC) protocol terminations towards the UE. The eNBs are connected by means of the S1 interface to the EPC (evolved packet core), which is made out of Mobility
15 Management Entities (MMEs) and/or gateways such as an access gateway (aGW). The S1 interface supports a many-to-many relation between MMEs and eNBs. Packet Data Convergence Protocol (PDCP) is located in an eNB.

In this example there exists an X2 interface between the eNBs that need to communicate with each other. For exceptional cases (e.g. inter-PLMN handover),
20 LTE_ACTIVE inter-eNB mobility is supported by means of MME relocation via the S1 interface.

The eNB may host functions such as radio resource management (radio bearer control, radio admission control, connection mobility control, dynamic allocation of resources to UEs in both uplink and downlink), selection of a mobility management entity (MME) at UE
25 attachment, scheduling and transmission of paging messages (originated from the MME), scheduling and transmission of broadcast information (originated from the MME or O&M), and measurement and measurement reporting configuration for mobility and scheduling. The MME may host functions such as the following: distribution of paging messages to the eNBs,

security control, IP header compression and encryption of user data streams; termination of U-plane packets for paging reasons; switching of U-plane for support of UE mobility, idle state mobility control, System Architecture Evolution (SAE) bearer control, and ciphering and integrity protection of NAS signaling.

5 In mobile telecommunications, the two basic types of power control are open-loop and closed-loop. In open-loop power control (OLPC), a mobile terminal measures received pilot signal power and accordingly sets the transmission power density (PDS) according to this measured quantity, and based on the pilot transmitted power, the S(I)NR target, and the interference level (these last values are usually broadcasted by the base station). In closed-
10 loop power control, the measurements are done on the other end of the connection, in the base station, and the results are then sent back to the mobile terminal so that the mobile terminal can adjust its transmission power. Note that the term “base station” is used broadly in this application, and may refer to a Node B, or an eNodeB, or the like.

 The current trend in the art is that uplink power control will include: (i) an open loop
15 power control mechanism at the terminal, as well as (ii) options for the eNode-B to send closed loop power control correction commands to the terminal. The current invention solves problems that occur with uplink power control and associated signalling from the terminal to the base station (eNode-B) to facilitate efficient uplink radio resource management decisions at the eNode-B.

20 Given this uplink power control scheme, the eNode-B may be unaware of the transmit power level at which different terminals are operating. This information is important for the eNode-B, because this knowledge is needed for optimal radio resource management decisions such as allocating MCS (modulation and coding scheme) and transmission bandwidth for the different terminals. It therefore has been discussed in 3GPP that terminals should be able to
25 provide power control headroom reports to the eNode-B. The power control headroom report basically provides a measure of how close the terminal’s power spectral density (PSD) is to the maximum PSD limit. The maximum PSD might be derived from the maximum UE

transmit power (typically assumed to be on the order of 24 dBm) and the minimum bandwidth (typically 1 PRB).

Unfortunately, 3GPP has not yet been able to find satisfactory criteria for sending a power control headroom report from the user terminal to the eNode-B. In LTE uplink (UL), the eNode-B makes the scheduling and radio resource management decisions such as selecting the UEs to transmit, allocating the UE transmission bandwidths, and (as mentioned above) selecting the MCS they should use. These decisions are then signalled to the terminal(s) via dedicated signalling (e.g. UL scheduling grant message). And, in order to make these decisions properly, the eNode-B should be aware of the power level at which the terminals are transmitting, or some equivalent information like the power headroom information, since from this information the eNodeB derives which MCS can be supported in the future with a targeted block error rate (BLER) which would be otherwise not possible. Knowing at the eNode-B the power spectral density used by the mobile terminals is particularly important when selecting the transmission bandwidth (rather than the MCS). Not knowing with precision the PSD used by a mobile terminal when selecting the MCS has only a major impact in case of slow AMC (in which case the PSD is "automatically" increased/decreased when the MCS is modified).

Consequently, reporting of power headroom or some equivalent information is needed. However, reporting of the power control headroom is a trade-off between uplink signalling overhead versus performance improvements that result from having this information readily available at the eNode-B.

It is problematic to have the terminal periodically report the power control headroom at a frequency higher than the adjustments of the actual terminal power spectral density (PSD). Further, the aim of these power adjustments at the terminal is basically to (partly or fully) compensate the path-loss (including antenna-pattern, distance dependent path-loss and shadowing) between the eNode-B and the terminal, and the measurement of path-loss is done based on the DL (e.g. DL pilot channel). Even if the frequency of potential power adjustments at the terminal is high but the measured path-loss is not changing, UL signalling

would be a waste of resources; the only issue then for reporting would be if closed loop power control commands would come from the eNodeB and some of those commands would be misinterpreted at the UE. Then, the problem occurs that the eNodeB does not know the used transmission power. The problem with power control commands being misinterpreted at the mobile terminal is only an issue if relative closed loop power control commands are used (which is also the working assumption in 3GPP).

In HSUPA, the UE Power Headroom (UPH) is part of the Scheduling Information (SI), which is transmitted by the UE as part of the MAC-e header. If the UE is not allocated resources for the transmission of scheduled-data, then Scheduling Information can be transmitted periodically and/or based on specific triggers (i.e. when data arrives in the buffer). Otherwise, only periodic reporting is supported.

Summary of the Invention

Although the present invention is applicable in the context of the E-UTRAN (LTE or 3.9G), its principles are not limited to such an environment, and instead may also be applicable to various other current and future wireless telecommunications systems and access technologies. This invention provides specific reporting criteria that are an attractive trade-off between signalling overhead versus overall uplink performance for LTE. The following triggering criteria are found to be very efficient for sending a power control headroom report in the uplink, while optimizing uplink performance, and while minimizing signalling overhead.

The first triggering criterion is that, once “n” closed loop power corrections have been received by a terminal (sent from the eNode-B), the power control headroom is measured by the terminal over the next “m” transmission time intervals (TTIs) and afterwards reported to the eNode-B. The reason for this first criterion is, as already mentioned above, that the closed loop commands can be misinterpreted at the terminal and therefore tracking of power status at the eNodeB would lead to the accumulation of such errors. The problem with power control commands being misinterpreted at the mobile terminal is only an issue if relative closed loop

power control commands are used (which is also the working assumption in 3GPP).

The second triggering criterion is that, after the terminal's open loop power control algorithm modifies the PSD, the terminal shall measure the power control headroom over the following "m" TTIs and afterwards report it to the eNode-B.

5 The third triggering criterion is that, in order to further limit the signalling of uplink power control headroom reports, the terminal shall only send a new power control headroom report if the time since the last reporting exceeds "k" TTIs.

And, the fourth triggering criterion is that, instead of the third triggering criterion, another embodiment of the invention is that the terminal shall only send a new power control
10 headroom report if the absolute difference between the current and the latest path-loss measurement is higher than a given threshold "p".

The three aforementioned quantities "n", "m", "k" (or "p" if the fourth rather than third triggering criterion is used) are parameters that are configured by the eNode-B. As an example, these parameters can be configured via RRC signalling from the eNode-B to the
15 terminal. These described triggering criteria can be combined (e.g. using a logical "OR" combination).

Brief Description of the Drawings

Figure 1 shows a UTRAN network.

20 Figure 2 shows an LTE architecture.

Figure 3 is a flow chart showing an embodiment of a method according to the present invention.

Figure 4 is a block diagram of a system according to an embodiment of the present invention.

Detailed Description of the Invention

25 A preferred embodiment of the present invention will now be described. This is merely to illustrate one way of implementing the invention, without limiting the scope or coverage of what is described elsewhere in this application.

In this preferred embodiment, the reporting criteria are implemented in the terminal. However, the protocol for signalling the parameters “n”, “m”, “k” and/or “p” requires implementation at both the eNode-B and the terminal. This embodiment of the invention provides an attractive trade-off between signalling overhead and performance.

5 As seen in FIG. 3, the method 300 can begin with the base station adjusting 307 one or more of the thresholds “n”, “m”, “k” and/or “p” at the user equipment (UE) by signalling to the UE. At some subsequent point in time, the UE determines 315 that a triggering criterion has been met because one of those thresholds have been reached (or some combination of those thresholds have been reached). This will trigger the UE to provide 325
10 a power control headroom report on the uplink. When this report is received 335 at the base station, the base station will then use that report to help provide 370 a closed loop power control correction command to the user equipment.

Referring now to FIG. 4, a system 400 is shown according to an embodiment of the invention, including a network element 492 and a user equipment 405. At the network
15 element, a threshold adjustment module 468 instructs transceiver 454 to send a threshold adjustment signal to the user equipment. At some subsequent point, a triggering module 413 at the user equipment determines that the threshold has been reached, and therefore instructs transceiver 411 to provide a power control headroom report to the network element, which processes the report in a report receiving module 463. The report receiving module 463 will
20 thereby help the network element to provide a closed loop power control correction command to the user equipment 405.

Each of the embodiments described above can be implemented using a general purpose or specific-use computer system, with standard operating system software conforming to the method described herein. The software is designed to drive the operation
25 of the particular hardware of the system, and will be compatible with other system components and I/O controllers. The computer system of this embodiment includes a CPU processor, comprising a single processing unit, multiple processing units capable of parallel operation, or the CPU can be distributed across one or more processing units in one or more

locations, e.g., on a client and server. A memory may comprise any known type of data storage and/or transmission media, including magnetic media, optical media, random access memory (RAM), read-only memory (ROM), a data cache, a data object, etc. Moreover, similar to the CPU, the memory may reside at a single physical location, comprising one or more types of data storage, or be distributed across a plurality of physical systems in various forms.

It is to be understood that the present figures, and the accompanying narrative discussions of best mode embodiments, do not purport to be completely rigorous treatments of the method, system, mobile device, network element, and software product under consideration. A person skilled in the art will understand that the steps and signals of the present application represent general cause-and-effect relationships that do not exclude intermediate interactions of various types, and will further understand that the various steps and structures described in this application can be implemented by a variety of different sequences and configurations, using various different combinations of hardware and software which need not be further detailed herein.

The invention includes a variety of concepts, which can be briefly described as follows, without in any way limiting what will be claimed in the future in reliance upon this provisional application. It is to be understood that the following concepts can be further combined with each other in any multiple dependent manner, without departing from the scope of the invention.

Claims

1. A method (300) comprising:
determining (315) that a set of at least one triggering criterion is met; and
providing (325) a power control headroom report on an uplink from user equipment,
5 in response to determining that the set is met,
wherein said at least one triggering criterion include a threshold having been reached.
2. The method of claim 1, wherein said threshold is adjustable via a signal to the
user equipment.
10
3. The method of claim 1, wherein the set comprises a criterion such that an
absolute difference between current and most recent path-loss measurements has reached a
threshold of difference.
- 15 4. The method of claim 1, wherein said set of at least one triggering criterion include
any one of a plurality of criteria that each entail reaching a respective threshold.
5. The method of claim 4, wherein the plurality of criteria comprise a first criterion,
a second criterion, and a third criterion.
20
6. The method of claim 1, wherein the set comprises a criterion such that a number
of received closed loop power corrections has reached a threshold of corrections.
7. The method of claim 1, wherein the set comprises a criterion such that an amount
25 of transmission time intervals, following an open loop power control modification, has
reached a threshold of intervals since modification.
8. The method of claim 1, wherein the set comprises a criterion such that an amount

of transmission time intervals, following a previous power control headroom report, has reached a threshold of intervals since reporting.

9. The method of claim 5,

5 wherein the first criterion is such that a number of received closed loop power corrections has reached a threshold of corrections, and

wherein the second criterion is such that an amount of transmission time intervals, following an open loop power control modification, has reached a threshold of intervals since modification.

10

10. The method of claim 9, wherein the third criterion is such that an amount of transmission time intervals, following a previous power control headroom report, has reached a threshold of intervals since reporting.

15

11. The method of claim 9, wherein the third criterion is such that an absolute difference between current and most recent path-loss measurements has reached a threshold of difference.

12. An apparatus (405) comprising:

20

means (413) for determining that a set of at least one triggering criterion is met; and

means (411) for providing a power control headroom report on an uplink from user equipment, in response to the set having been met,

wherein said at least one triggering criterion include a threshold having been reached.

25

13. The apparatus of claim 12, wherein said threshold is adjustable via a signal to the user equipment.

14. The apparatus of claim 12, wherein the set comprises a criterion such that an

absolute difference between current and most recent path-loss measurements has reached a threshold of difference.

5 15. The apparatus of claim 12, wherein said set of at least one triggering criterion include any one of a plurality of criteria that each entail reaching a respective threshold.

10 16. The apparatus of claim 15, wherein the plurality of criteria comprise a first criterion, a second criterion, and a third criterion.

17. The apparatus of claim 16,
wherein the first criterion is such that a number of received closed loop power corrections has reached a threshold of corrections, and
wherein the second criterion is such that an amount of transmission time intervals,
15 following an open loop power control modification, has reached a threshold of intervals since modification.

18. The apparatus of claim 17, wherein the third criterion is such that an amount of transmission time intervals, following a previous power control headroom report,
20 has reached a threshold of intervals since reporting.

19. The apparatus of claim 17, wherein the third criterion is such that an absolute difference between current and most recent path-loss measurements has reached a threshold of difference.

25 20. Apparatus (405) comprising:
a triggering module (413) configured to determine that a set of at least one triggering criterion is met; and

a transceiver (411) configured to provide a power control headroom report on an uplink from said user equipment, in response to the set having been met, wherein said at least one triggering criterion include a threshold having been reached.

5 21. The apparatus of claim 20, wherein said threshold is adjustable via a signal to the apparatus.

 22. The apparatus of claim 20, wherein the set comprises a criterion such that an absolute difference between current and most recent path-loss measurements has reached a
10 threshold of difference.

 23. The apparatus of claim 20, wherein said set of at least one triggering criterion include any one of a plurality of criteria that each entail reaching a respective threshold.

15 24. The apparatus of claim 23, wherein the plurality of criteria comprise a first criterion, a second criterion, and a third criterion.

 25. The apparatus of claim 24,
 wherein the first criterion is such that a number of received closed loop power
20 corrections has reached a threshold of corrections, and
 wherein the second criterion is such that an amount of transmission time intervals, following an open loop power control modification, has reached a threshold of intervals since modification.

25 26. The apparatus of claim 24, wherein the third criterion is such that an amount of transmission time intervals, following a previous power control headroom report, has reached a threshold of intervals since reporting.

27. The apparatus of claim 24, wherein the third criterion is such that an absolute difference between current and most recent path-loss measurements has reached a threshold of difference.

5 28. A computer program product comprising a computer readable medium having executable code stored therein; the code, when executed by a processor, adapted to carry out the functions of:

 determining (315) that a set of at least one triggering criterion is met; and
 providing (325) a power control headroom report on an uplink from user equipment,
10 in response to the set having been met,
 wherein said at least one triggering criterion include a threshold having been reached.

 29. The computer program product of claim 28, wherein said threshold is adjustable via a signal to the user equipment.

15

 30. The computer program product of claim 28, wherein the set comprises a criterion such that an absolute difference between current and most recent path-loss measurements has reached a threshold of difference.

20 31. The computer program product of claim 28, wherein said set of at least one triggering criterion include any one of a plurality of criteria that each entail reaching a respective threshold.

 32. The computer program product of claim 31, wherein the plurality of criteria
25 comprise a first criterion, a second criterion, and a third criterion.

 33. The computer program product of claim 32,
 wherein the first criterion is such that a number of received closed loop power

corrections has reached a threshold of corrections, and

wherein the second criterion is such that an amount of transmission time intervals, following an open loop power control modification, has reached a threshold of intervals since modification.

5

34. A network element (492) comprising:

a report receiving module (463) configured to receive a power control headroom report on an uplink from user equipment, in response to the user equipment determining that a set of at least one triggering criterion is met because a threshold has been reached, and

10 a threshold adjustment module (468) , configured to provide a threshold adjustment signal to the user equipment in order to adjust the threshold.

35. The network element of claim 34, wherein the set comprises a criterion such that an absolute difference between current and most recent path-loss measurements has reached a
15 threshold of difference.

36. The network element of claim 34, further comprising a correction module configured to provide a closed loop power control correction command signal to the user equipment at least partly in response to said power control headroom report.

20

37. A system (400) comprising:

user equipment (405) having a triggering module (413) configured to determine that a set of at least one triggering criterion is met, and having a transceiver (411) configured to provide a power control headroom report on an uplink from said user equipment, in response
25 to the set having been met, wherein said at least one triggering criterion include a threshold having been reached; and

a network element (492) having a report receiving module (463) configured to receive a power control headroom report on an uplink from user equipment, in response to the user

equipment determining that a set of at least one triggering criterion is met because said threshold has been reached, and having a threshold adjustment module (468) configured to provide a threshold adjustment signal to the user equipment in order to adjust the threshold.

5 38. The system of claim 37, wherein the set comprises a criterion such that an absolute difference between current and most recent path-loss measurements has reached a threshold of difference.

 39. The system of claim 37,
10 wherein the set comprises a first criterion, a second criterion, and a third criterion,
 wherein the first criterion is such that a number of received closed loop power corrections has reached a threshold of corrections, and
 wherein the second criterion is such that an amount of transmission time intervals, following an open loop power control modification, has reached a threshold of intervals since
15 modification.

FIG. 1

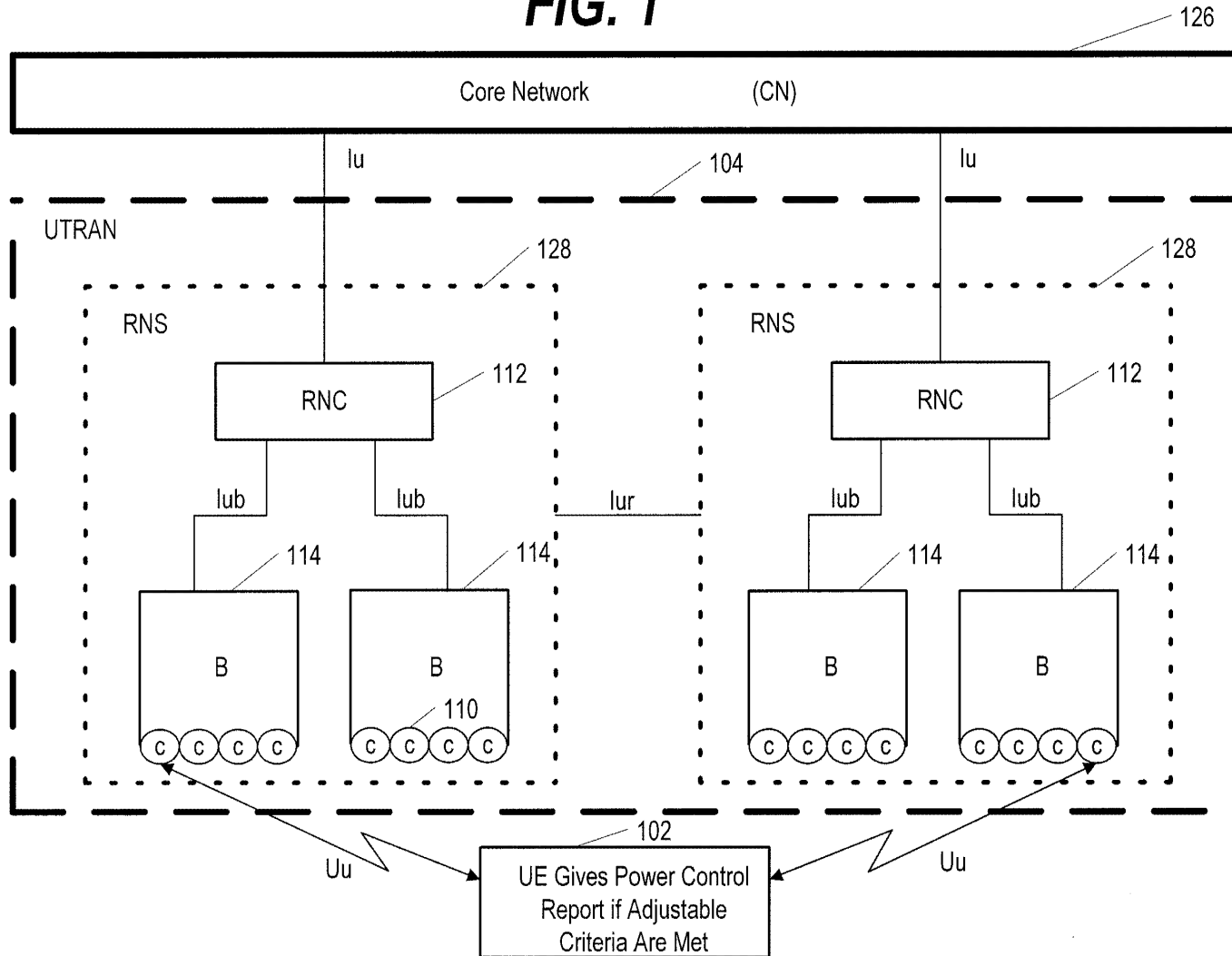

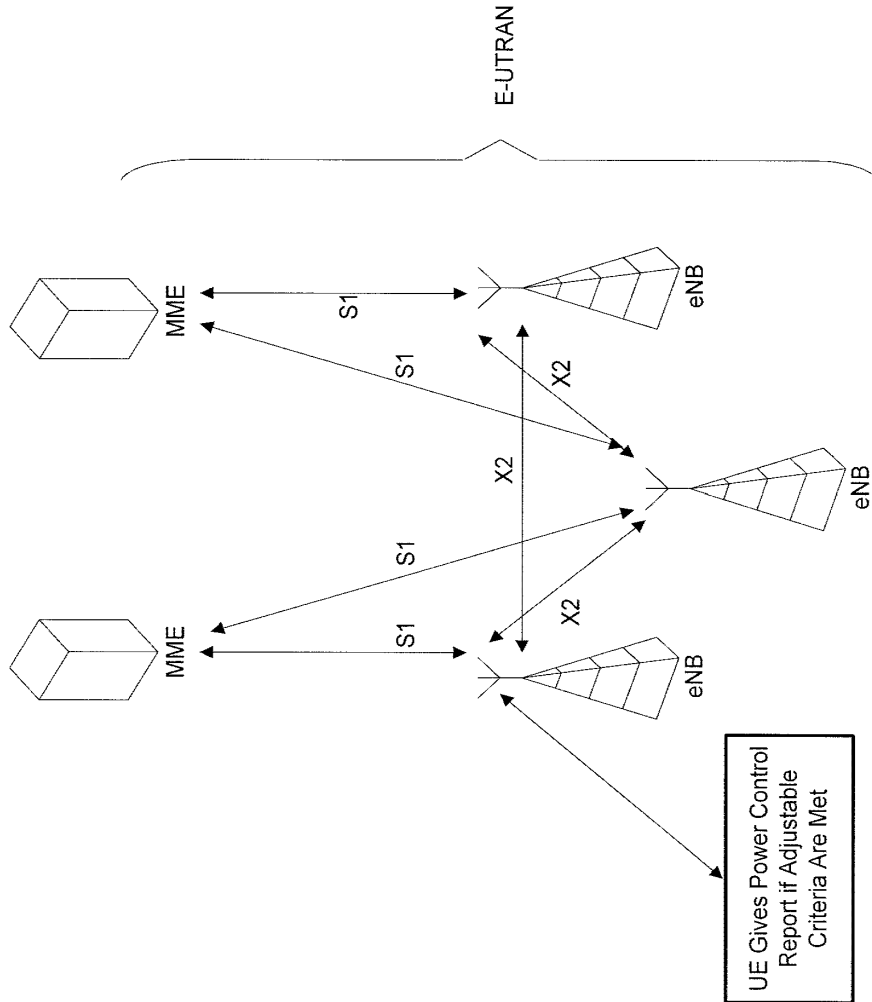

FIG. 2

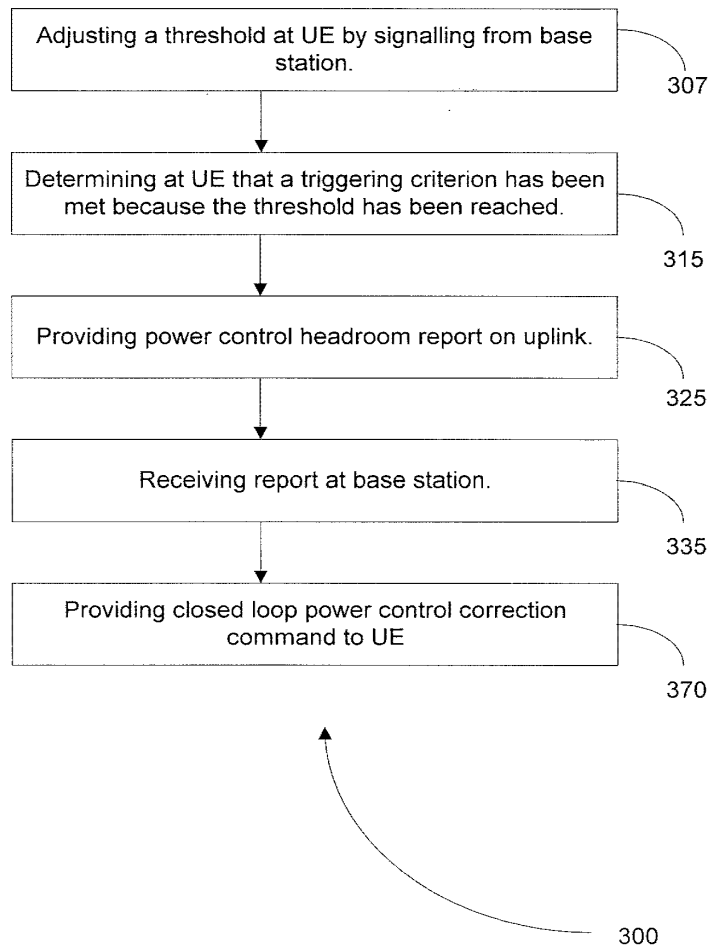

FIG. 3

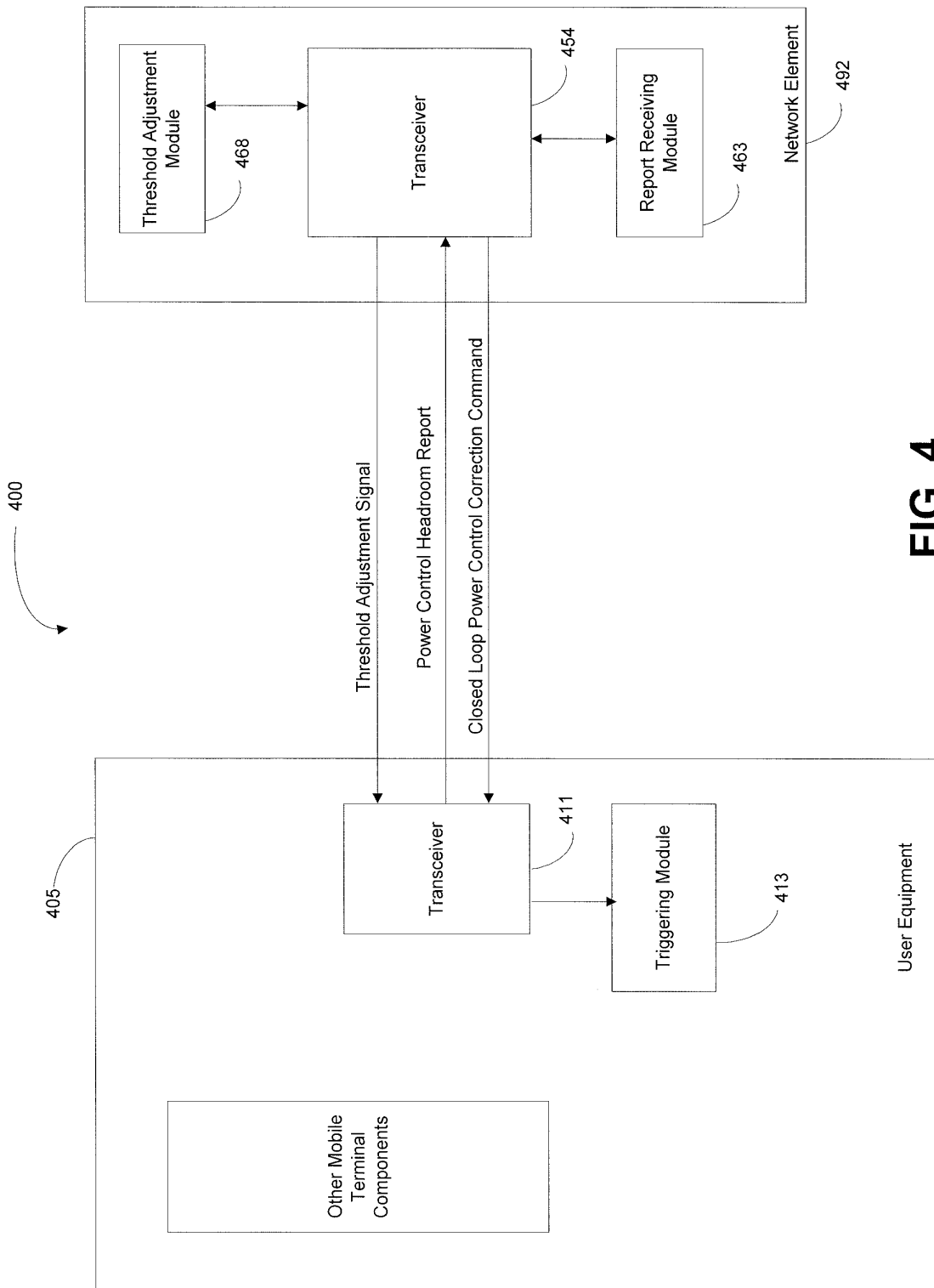

FIG. 4

INTERNATIONAL SEARCH REPORT

International application No.

PCT/FI2008/050384

A. CLASSIFICATION OF SUBJECT MATTER												
See extra sheet												
According to International Patent Classification (IPC) or to both national classification and IPC												
B. FIELDS SEARCHED												
Minimum documentation searched (classification system followed by classification symbols)												
IPC8: H04B												
Documentation searched other than minimum documentation to the extent that such documents are included in the fields searched												
FI, SE, NO, DK												
Electronic data base consulted during the international search (name of data base and, where practicable, search terms used)												
EPO-internal, WPI, XPIEE, XPI3E												
C. DOCUMENTS CONSIDERED TO BE RELEVANT												
Category*	Citation of document, with indication, where appropriate, of the relevant passages	Relevant to claim No.										
A	WO 0003499 A1 (SAMSUNG ELECTRONICS CO LTD) 20 January 2000 (20.01.2000), abstract; page 4, lines 1-24; claim 1	1-39										
A	EP 1628413 A2 (SAMSUNG ELECTRONICS CO LTD) 22 February 2006 (22.02.2006), abstract; paragraphs [0034] – [0043]	1-39										
A	US 2003026324 A1 (LI D. et al.) 06 February 2003 (06.02.2003), abstract; paragraphs [0011] – [0021]	1-39										
A	EP 1311076 A1 (LUCENT TECHNOLOGIES INC) 14 May 2003 (14.05.2003), abstract; paragraphs [0014] – [0025]	1-39										
A	WO 0062441 A1 (ERICSSON TELEFON AB L M) 19 October 2000 (19.10.2000), abstract; page 8, lines 1-28; page 9, lines 1-22	1-39										
<input type="checkbox"/> Further documents are listed in the continuation of Box C. <input checked="" type="checkbox"/> See patent family annex.												
* Special categories of cited documents: <table border="0"> <tr> <td>"A" document defining the general state of the art which is not considered to be of particular relevance</td> <td>"T" later document published after the international filing date or priority date and not in conflict with the application but cited to understand the principle or theory underlying the invention</td> </tr> <tr> <td>"E" earlier application or patent but published on or after the international filing date</td> <td>"X" document of particular relevance; the claimed invention cannot be considered novel or cannot be considered to involve an inventive step when the document is taken alone</td> </tr> <tr> <td>"L" document which may throw doubts on priority claim(s) or which is cited to establish the publication date of another citation or other special reason (as specified)</td> <td>"Y" document of particular relevance; the claimed invention cannot be considered to involve an inventive step when the document is combined with one or more other such documents, such combination being obvious to a person skilled in the art</td> </tr> <tr> <td>"O" document referring to an oral disclosure, use, exhibition or other means</td> <td>"&" document member of the same patent family</td> </tr> <tr> <td>"P" document published prior to the international filing date but later than the priority date claimed</td> <td></td> </tr> </table>			"A" document defining the general state of the art which is not considered to be of particular relevance	"T" later document published after the international filing date or priority date and not in conflict with the application but cited to understand the principle or theory underlying the invention	"E" earlier application or patent but published on or after the international filing date	"X" document of particular relevance; the claimed invention cannot be considered novel or cannot be considered to involve an inventive step when the document is taken alone	"L" document which may throw doubts on priority claim(s) or which is cited to establish the publication date of another citation or other special reason (as specified)	"Y" document of particular relevance; the claimed invention cannot be considered to involve an inventive step when the document is combined with one or more other such documents, such combination being obvious to a person skilled in the art	"O" document referring to an oral disclosure, use, exhibition or other means	"&" document member of the same patent family	"P" document published prior to the international filing date but later than the priority date claimed	
"A" document defining the general state of the art which is not considered to be of particular relevance	"T" later document published after the international filing date or priority date and not in conflict with the application but cited to understand the principle or theory underlying the invention											
"E" earlier application or patent but published on or after the international filing date	"X" document of particular relevance; the claimed invention cannot be considered novel or cannot be considered to involve an inventive step when the document is taken alone											
"L" document which may throw doubts on priority claim(s) or which is cited to establish the publication date of another citation or other special reason (as specified)	"Y" document of particular relevance; the claimed invention cannot be considered to involve an inventive step when the document is combined with one or more other such documents, such combination being obvious to a person skilled in the art											
"O" document referring to an oral disclosure, use, exhibition or other means	"&" document member of the same patent family											
"P" document published prior to the international filing date but later than the priority date claimed												
Date of the actual completion of the international search		Date of mailing of the international search report										
21 October 2008 (21.10.2008)		27 October 2008 (27.10.2008)										
Name and mailing address of the ISA/FI		Authorized officer										
National Board of Patents and Registration of Finland P.O. Box 1160, FI-00101 HELSINKI, Finland		Pasi Suvikunnas										
Facsimile No. +358 9 6939 5328		Telephone No. +358 9 6939 500										

Form PCT/ISA/210 (second sheet) (July 2008)

INTERNATIONAL SEARCH REPORT
Information on patent family members

International application No.
PCT/FI2008/050384

Patent document cited in search report	Publication date	Patent family members(s)	Publication date
WO 0003499 A1	20/01/2000	US 6512931 B1	28/01/2003
		RU 2187893 C2	20/08/2002
		EP 1013006 A1	28/06/2000
		CN 1272987 A	08/11/2000
		CA 2299575 A1	20/01/2000
		BR 9906825 A	15/08/2000
		AU 4656899 A	01/02/2000
EP 1628413 A2	22/02/2006	HR 20070049 A2	31/08/2007
		BR PI0514446 A	10/06/2008
		JP 2008511201T T	10/04/2008
		CN 101044700 A	26/09/2007
		CA 2576383 A1	23/02/2006
		AU 2005273089 A1	23/02/2006
		KR 20060017314 A	23/02/2006
		US 2006040619 A1	23/02/2006
		WO 2006019287 A1	23/02/2006
US 2003026324 A1	06/02/2003	US 2005254467 A1	17/11/2005
		WO 02069525 A1	06/09/2002
EP 1311076 A1	14/05/2003	DE 60127138T T2	22/11/2007
		US 2003092463 A1	15/05/2003
WO 0062441 A1	19/10/2000	AT 410835T T	15/10/2008
		TW 462155B B	01/11/2001
		JP 2002542655T T	10/12/2002
		EP 1169785 A1	09/01/2002
		CN 1355964 A	26/06/2002
		CA 2369918 A1	19/10/2000
		AU 4161500 A	14/11/2000
US 6334047 B1	25/12/2001		

INTERNATIONAL SEARCH REPORT

International application No.
PCT/FI2008/050384

CLASSIFICATION OF SUBJECT MATTER

Int.Cl.
H04B 7/005 (2006.01)

(19)



Europäisches Patentamt
European Patent Office
Office européen des brevets



(11) **EP 1 311 076 A1**

(12)

EUROPEAN PATENT APPLICATION

(43) Date of publication:
14.05.2003 Bulletin 2003/20

(51) Int Cl.7: **H04B 7/005**

(21) Application number: **01309520.3**

(22) Date of filing: **12.11.2001**

(84) Designated Contracting States:
**AT BE CH CY DE DK ES FI FR GB GR IE IT LI LU
MC NL PT SE TR**
Designated Extension States:
AL LT LV MK RO SI

- **Mueckenheim, Jens**
90411 Nuremberg (DE)
- **Gunreben, Peter C.**
91096 Moehrendorf (DE)

(71) Applicant: **LUCENT TECHNOLOGIES INC.**
Murray Hill, New Jersey 07974-0636 (US)

(74) Representative: **Sarup, David Alexander et al**
Lucent Technologies NS UK Limited,
5 Mornington Road
Woodford Green, Essex IG8 OTU (GB)

(72) Inventors:
• **Charriere, Patrick G.V.**
Tetbury, Gloucestershire GL8 8DR (GB)

(54) **Control of the transmission power of a CDMA based system**

(57) The invention relates to the controlling of transmission power in the uplink direction of a CDMA-based radio system. An object of the invention is, to provide a new and significantly improved approach for controlling the transmission power in the uplink direction of a CDMA-based radio system in particular providing a transmission power control even with regard to an overall link quality substantially involving a real time reaction on changes in the environment. The invention proposes to provide a CDMA-based radio system comprising an inner power control loop (ILPC) adjusting the transmission power (TXpwr) between an user equipment (UE) and at least one base station (NodeB1, NodeB2) based on the signal to interference ratio (SIR) to ensure that the signal to interference ratio (SIR) is similar to a target signal to

interference ratio (SIRt1, SIRt2) at least within a predefined range and an outer power control loop (OLPC) for adjusting said target signal to interference ratio (SIRt1, SIRt2) based on the link quality (BLER) to ensure a target link quality necessary for fulfilling a predetermined quality of service in view of link quality at least within a predefined range, wherein the outer power control loop is provided by establishing a first outer power control loop (OLPCb) between said at least one base station (NodeB1, NodeB2) and said user equipment (UE) and by establishing a second outer power control loop (OLPCa) between an associated serving radio control means (SRNC) and the at least one base station (NodeB1, NodeB2).

EP 1 311 076 A1

Description

[0001] The invention relates to a method and apparatuses for controlling the transmission power in the uplink direction of a CDMA-based radio system.

[0002] In particular with regard to third-generation (3G) wireless communication networks, Code Division Multiple Access (CDMA) techniques are used in the respective radio access network. In such a CDMA-based-wireless communication network and especially for the reverse link or uplink relating to the physical channel from a user equipment, such as a mobile station, to the network, the effect of mutual interference is not negligible. Consequently the control of transmission power is very critical for the overall system performance of the radio access networks and hence, in CDMA-networks the power control is usually split into a fast inner loop and a slower outer loop of power control.

[0003] In detail, the inner loop providing fast power control has to mitigate changes in the ratio between signal and interference (SIR). Normally the changes of such signal to interference ratio are caused by fast fading, such as Rayleigh or Ricean fading, by shadowing, e.g. log-normal fading or by changes in the interference level. Ideally the received SIR should remain constant to enable a good reception of the reverse link signal without wasting transmit power at the user equipment. Actually, the inner loop has to adjust the transmit power at the user equipment such that the resulting SIR at the respective base transceiver station (BTS) of the network stays as close as possible to a target value of SIR.

[0004] The outer power control loop providing slow power control has to control the current link quality, usually in terms of bit error rate (BER) or block error rate (BLER) depending on requirements of the respective radio bearer service. The received link quality however may still change although the SIR is controlled by the inner power control loop. These changes are particularly caused by variations in a multipath delay profile based for example on typical urban and/or hilly terrain, by alterations in the speed of the user equipment or by modifications in the interference characteristics. Consequently the outer power control loop has to adapt the aforementioned target value of SIR of the inner loop such that the required link quality is met.

[0005] In CDMA-systems according to the IS-95 standard, the uplink inner and outer power control loop, i.e. for the transmission from a user equipment to the network, are both located in the base transceiver stations (BTS). For the inner power control loop the received SIR is estimated at the BTS and is compared against the target SIR. If the estimated SIR is greater than the target SIR, a power-down command is sent to the user equipment using the forward link control channel. Accordingly a power-up command is sent if the estimated SIR is below the target SIR. Thus the power command is generally based on values "up" and "down". After the user equipment has received a respective pow-

er command which is sent periodically 800 times per second, the transmit power is correspondingly changed by a predefined power step usually based on dB. If the user equipment however is in a soft handover procedure, it combines the power commands of the respectively associated base transceiver stations. In particular the user equipment decreases its transmit power if any of the power commands asks the user equipment to decrease the transmit power and hence, a transmit power increase is only performed if all power commands are power "up" commands.

[0006] With regard to the outer power loop control of such IS-95 systems the BLER performance of a respective radio link is determined by checking the received frames or blocks for errors usually using a so called Cyclic Redundancy Check (CRC). If the CRC fails, the block is in error. To meet the required BLER the target SIR is increased by predefined power up step in dB, if a block was detected to be wrong. If the block was received correctly, the target SIR will be decreased by a fraction of the power up step. The correct BLER will be met if the power down step equals the power up step times the target BLER divided by "1-target BLER". In soft handover procedures however all base transceiver stations execute their outer power control loop algorithms independently. Consequently every base station tries to set the target SIR such that the respective required link quality is met.

[0007] Thus one of the problems of a CDMA-system according to the IS-95 standard is that in soft handover procedures the uplink outer power control loop is only able to control the link quality of one respective link leg. Since all the links are combined in a frame selection means, which is located in a respective radio network controller the outer power control loop is not able to control the overall link quality after frame selection is performed, due to the fact that the outer power control loop is located in the base transceiver station where no information of the link quality after frame selection is available. Consequently each of the link legs in soft handover procedures will try to achieve the target quality and hence the target SIR values at the base transceiver stations will be set higher than necessary. Thus the SIR and accordingly the transmit power will be higher than necessary, whereby such transmit power causes a waste in system capacity.

[0008] In a UMTS (Universal Mobile Telecommunication System) system the uplink inner power control loop is also located at the base transceiver stations, with the functionality of the uplink inner loop basically similar to the uplink inner power control loop according to the aforementioned IS-95 based system. The only difference is that the power commands are sent 1500 times per second.

[0009] However, different to IS-95 based systems a system based on the UMTS is provided with an uplink outer power control loop which is located in the radio network controller and thus it is possible to evaluate the

link quality immediately after frame selection is performed. Consequently the link quality requirements are related exactly to the measurable link quality.

[0010] One of the main drawbacks of such a UMTS decentralized power control concept however, is the large signaling delay between the base transceiver stations and the network controller. In particular with respect to the power control the signaling delay located between the inner and the outer power control loop is degrading the speed and performance of the outer power control loop significantly. This causes that a reaction on changes in the environment will be delayed and the control loop needs to slow down to avoid instability problems. Moreover the decentralized architecture also implies an additional signaling traffic load on the link between the radio network controller (RNC) and an associated NodeB, which may result in problems for radio network operators who depend on third party operators for the connection between the radio network controllers and the NodeBs.

[0011] Accordingly, an object of the invention is, to provide with regard to the aforesaid state of the art, a new and significantly improved approach for controlling the transmission power in the uplink direction of a CDMA-based radio system avoiding the current drawbacks or problems and in particular providing a transmission power control even with regard to an overall link quality substantially involving a real time reaction on changes in the environment.

[0012] The inventive solution is achieved by a method incorporating the features of claim 1 and by a UMTS-system, a transceiver apparatus and a software implementation product respectively incorporating the features of claim 8, 9 or 10.

[0013] Advantage and/or preferred embodiments or refinements are the subject matter of the respective dependent claims.

[0014] Accordingly the invention proposes to provide an inner power control loop for adjusting the transmission power between a user equipment and at least one base transceiver station based on the signal to interference ratio such that a target signal to interference ratio at least within a predefined range is ensured and an outer power control loop for adjusting said target signal to interference ratio based on link quality such that a target link quality is ensured wherein the outer power control loop is based on a combination of a first outer power control loop established between said at least one base station and said user equipment and of a second outer power control loop established between an associated serving radio control means and the at least one base station.

[0015] One of the main advantages is that by introducing a two-stage uplink outer power control loop it is possible to fulfill both, the fast reaction on changes in the radio environment and the control of the overall link quality. Accordingly, the target link quality necessary for fulfilling a predetermined quality of service in view of link

quality and transmission delay, in particular based on retransmission of error signal components can be ensured, wherein the first outer power control loop established between the base station and the user equipment may adjust the target signal to interference ratio based on a link quality of a respective signal link which is usually different to said target link quality usually similar to a required overall link quality.

[0016] Accordingly the invention preferably proposes to establish the second outer power control loop such that it ensures the target link quality based on the overall link quality and is adjusting a reference link quality based on that target link quality for the first outer power control loop. Thus the first outer power loop is enabled to adjust said target signal to interference ratio based on link quality to ensure a kind of reference link quality which is set by the second outer power control loop and is usually different to the required overall link quality. Accordingly if the overall link quality is not good enough the reference link quality can be tightened. If however the overall link quality is too good the reference link quality may be weakened. Therefore the use of a reference link quality enables the control of the overall link quality without having the drawback of the large signaling delay between the inner and outer loop.

[0017] According to a preferred embodiment it is proposed to establish the first outer power control loop in the respective base station and the second outer power control loop in the a respective serving radio network controller so that the first control loop is responsible for the fast reaction on changes in the radio environment and the second control loop ensures the overall link quality requirements after frame selection. Accordingly by correcting the reference link quality based on signal to interference ratio measurement the main quality control can be performed in the base station. The reference quality correction in the network controller is used to adapt the residual overall link quality deviation due to the imperfect reference quality adaptation. Hence it is possible to use propriety link quality estimation techniques since the signal to interference ratio measurements need not be transferred to the radio network controller resulting in significant opportunities to the vendors to optimize the quality control without changing the standardized information flow.

[0018] According to a further preferred refinement it is suggested to deactivate said second outer power control loop based on a radio link between said user equipment and only one base station and to activate said second outer power control loop at least based on a multipath radio link being a link between said user equipment and a plurality of base stations.

[0019] Accordingly when the user equipment is connected through one signal radio link handled by one signal base station or even when the links are in softer handover over several sectors of the same base station the deactivation substantially avoids any control delay and extra signaling between the base station and the

respective radio network controller. If however the radio links related to the radio connection are handled by more than one base station the first and second outer power control loops run parallel and exchange information over the interfaces between the NodeB and the radio network controller for staying synchronized, wherein the second outer power control loop function preferably is the master control loop whereas the first outer power control loop has only the restricted decision-making power depending on the handicap of the second outer power control loop for fulfilling the required quality of services.

[0020] Moreover, according to a further preferred embodiment of the invention it is proposed that said first outer power control loop is restricting the target signal to interference ratio to a constant value and/or to a value having a predefined increase based on two successive values in case said target signal to interference ratio is not met by the inner power control loop. With such a restriction of the adjustment of the target signal to interference ratio a wind-up effect due to an impact of one of the radio links, that is not significant on the inner power control loop is avoided.

[0021] To further improve the convergence of the overall link quality according to a very preferred embodiment it is further proposed to adapt the reference link quality depending on the difference between the target signal to interference ratio and the respective current signal to interference ratio by the first outer power control loop to avoid too heavy changes in the overall link quality in particular if the combining gain of the frame selection is changing.

[0022] Moreover, for further reducing the signaling load for the respective associated radio network controller with regard to the base transceiver stations and/or with regard to a plurality of drift radio network controllers it is further suggested that said first outer power control loop is generating said target signal to interference ratio faster than said second outer power control loop is generating said reference link quality.

[0023] Correspondingly the invention is additionally providing an UMTS system adapted to perform the inventive method by incorporating means adapted to provide a first outer power control loop between at least one base station and a user equipment for adjusting a target signal to interference ratio and means adapted to establish a second outer power control loop between an associated serving radio controller and the at least one base station for ensuring a target link quality necessary for fulfilling a predetermined quality of service.

[0024] Moreover a transceiver apparatus is provided having means for adjusting a target signal to interference ratio based on link quality and adapted to be used for performing the inventive method, especially incorporated within an inventive UMTS-system.

[0025] Additionally, a software implementation product is provided adapted to perform the inventive two stage outer power control loop functionality, preferably

with an adaptable configuration dependent on the number and types of radio links activated to maintain the radio connection and on the messages exchanged between the different element of the radio network accordingly.

[0026] Subsequently the invention is exemplary described in more detail based on a preferred embodiment and with regard to accompanied drawings, in which:

Fig. 1 is schematically depicting an information flow example for a two-way handover scenario according to the invention,

Fig. 2 is schematically depicting an information flow example for the management of the inventive two-stage outer power control loop configuration changes, and

Fig. 3 is schematically illustrating the location of the uplink outer power control loop functionality in a UMTS-system according to the state of the art.

[0027] Firstly regarding Fig. 3 showing an exemplar illustration of location of the uplink outer power control loop OLPC of an exemplar UMTS-based network according to the state of the art to provide a better understanding of the invention. As can be seen in the UMTS-based network the uplink outer loop of power control OLPC is located in the radio network controller SRNC which is serving the links of a respective user equipment UE in particular of a mobile station. Furthermore also the frame selector "Frame Selector" for combining all received frames is located in that serving RNC.

[0028] As it is indicated by flashes in Fig. 3, there are a plurality of radio legs related to the radio connection of the user equipment UE that are handled by more than one base transceiver station each of which associated to a respective so called NodeB of the network. Consequently it is possible to evaluate the link quality immediately after frame selection, whereby the link quality requirements are related exactly to the measurable link quality.

[0029] Since however the uplink inner power control loop, even it is not indicated in Fig. 3 is located at the base stations, there is usually a large signaling delay between the base stations and the serving network controller SRNC degrading the speed and performance of the outer loop power control OLPC significantly. Reactions on changes in the environment will be delayed and the control loop needs to slow down to avoid instability problems. Hence such a decentralized architecture also implies an additional signaling traffic load on the links between the serving network controller SRNC and the NodeBs, i.e. on the link interfaces Iub. Moreover, in the case of a further drift network controller dRNC associated to at least one of the NodeBs also on the link interface Iur between the drift and the serving radio network

controllers dRNC and SRNC. The link interface Lu is used to exchange information between the serving RNC and the further core network.

[0030] In comparison thereto the outer power control loop OLPC according to the invention is distributed in general between the base transceiver station of the NodeB and the radio network controller SRNC, as can be seen in Fig. 1.

[0031] Fig. 1 shows an example for the information flow between network elements for the case of a two-way soft-handover and with the block error rate BLER used as the link quality criteria.

[0032] In detail, the schematically drafted user equipment UE is in two-way soft handover with the NodeB1 and the NodeB2. Thus the receiver of each of the base stations comprised by the NodeB1 or the NodeB2 receives an information signal which is transmitted by the transmitter of the user equipment UE using a certain transmission power TXpwr adjusted as described in the following by a unit means indicated as ILPCb. Each of the receivers are connected to an estimator for measuring the SIR ratio of the transmitted signal of the user equipment UE on the physical control channel. Furthermore, each of the NodeBs comprises an uplink inner power control loop ILPCa connected to the estimator and adapted to generate a power command TACc1 or TPCc2, respectively being a power-up or a power-down command by comparing the estimated signal to interference ratio SIRe1 or SIRe2 of the respective SIR estimator against a respective target signal to interference ratio SIRT1 or SIRT2. The power-up or the power-down commands TPCc1 and TPCc2 are then sent back to the user equipment UE on the downlink physical control channel so that in the drawn case the user equipment UE will receive by means of the unit ILPCb the transmission power command TPCc1 and TPCc2 from the base stations causing a change of the transmission power TXpwr of the user equipment UE by a predefined power step in dB.

[0033] As discussed above in the introduction portion, the mobile station UE combines the power commands in case of a soft-handover wherein the unit ILPCb will decrease the transmission power TXpwr if any of the power commands TPCc1 and TPCc2 is a power-down command and will increase the transmit power only if all power commands TPCc1 and TPCc2 are power-up commands.

[0034] According to the preferred embodiment as depicted, the NodeB1 and the NodeB2 also comprise a respective decoder connected to the respective receiver to decode the received data blocks of the signal transmitted by the user equipment UE and to evaluate a cyclic redundancy check in turn to evaluate whether the decoded block is in error or not. The result of this check, i.e. the cyclic redundancy check indication is denoted with CRCI1 and CRCI1, respectively. As known for a person skilled in the art such cyclic redundancy check CRCI is the most common measure for a block error rate

controlled link quality control.

[0035] The inventive distributed uplink outer power control loop OLPCa and OLPCb as described in more detail below enables the use of further quality estimation techniques, too. A further quality estimate QE1 or QE2 is shown in Fig. 1. This measurement or estimate need not be transferred to the serving radio network controller SRNC and can be any proprietary link quality measurement regardless of the standardized procedures because it does not need to distribute outside the base stations.

[0036] Regarding the inventive two-stage uplink outer power control loop OLPCa and OLPCb in more detail it is possible to fulfill both, the fast reaction on changes in the radio environment and the control of the overall link quality. As can be seen, a first outer power control loop OLPCb is located in each of the base transceiver stations of the NodeB1 or the NodeB2 to enable a fast reaction on changes in the radio environment. In soft-handover cases, as drafted by Fig. 1 for example, the overall link quality is usually different to the link quality of the single links. Thus the outer power control loop part OLPCb of a respective NodeB tries to achieve a kind of reference link quality BLERref brought forward by the serving radio network controller SRNC. This reference link quality BLERref is usually different to the required target overall link quality.

[0037] In particular, this reference link quality BLERref is set by a second outer power control loop part OLPCb which is located in the same network element as the frame selection, i.e. usually in the serving radio network controller SRNC. If the overall link quality is not good enough then the reference link quality BLERref requirement is tightened. If the overall target link quality is too good the reference link quality requirement BLERref is weakened. According to the exemplar using the block error rate as the link quality criteria such link quality is determined by using the cyclic redundancy check indications CRCI1 and CRCI2 of the respective base stations. If the combined redundancy check indication CRCI fails, the block or frame is in error. The combining gain of the frame selection is maximal if all the links have the same link quality. In this case the reference link quality BLERref will be worse than the overall required target link quality. By using such reference link quality BLERref, the control of the target or necessary overall link quality is enabled substantially without having any large signaling delay between the inner and outer loops of power.

[0038] Furthermore, according to preferred embodiments the first means of the outer loop for power control OLPCb is adapted in that any increase of the target signal to interference ratio SIRT1 or target SIRT2 is prohibited if the means of the inner loop for power control loop ILPCa and ILPCb has not met the target SIR SIRT1 or SIRT2 to a certain degree, previously. In other words a target SIR SIRT1 or SIRT2 increase is allowed only if the current SIR is greater than the target SIR SIRT1 or SIRT2

minus a tolerance margin. This enables to overcome any wind-up effect caused by situations in which one of the links has no significant impact on the inner power control loop ILPC.

[0039] Such a wind-up effect usually may be a result of a soft-handover, since the mobile station UE will only increase its transmit power TX_{pwr} if all power commands TACc1 and TPCc2 are requesting a power increase. If however one of the links requires a power decrease the mobile station UE will decrease its transmit power TX_{pwr} . Thus if one of the links has a worse SIR than the other one it is quite likely that the stronger link meets the SIR target while the SIR of the weaker link will be lower than the target. Thus without the restriction of target SIR increases, the first outer loop power control OLPCb of the base station which is receiving the weaker link will increase the target SIR, i.e. based on Fig. 1 SIRt1 or SIRt2. However, although that target SIR SIRt1 and/or SIRt2 has been increased, the stronger link will still control the SIR by sending power-up and/or power-down commands while the weaker link will mostly send power-up commands. Therefore, without the use of the invention, the target SIR SIRt1 or SIRt2 of the weaker link will wind-up step by step.

[0040] Moreover by use of the invention it is possible to improve the convergence of the overall link quality. Although the first part of the uplink outer loop for power control OLPCb located in the base station is controlling the link quality quite fast, the adaptation to the target link quality based on the required overall link quality is slower because of the still existing signaling delay between a respective NodeB and the serving radio network controller SRNC. If the overall link quality is worse than the required link quality it takes some time to adapt the reference link quality $BLER_{ref}$ until the required link quality is met. The strongest impact on the overall performance is seen if for example two strong links were in soft-handover, i.e. the reference link quality $BLER_{ref}$ was worsened causing an increase of the transmission power TX_{pwr} , and suddenly the soft-handover situation ends. In this case the reference link quality $BLER_{ref}$ is too bad until the second outer loop means for power control OLPCa adapts the reference quality $BLER_{ref}$ again.

[0041] Therefore to mitigate such a situation each linked NodeB preferably adapts the reference link quality $BLER_{ref}$ in definable functional dependence on the respective actual difference between the current SIR and the respective target SIR SIRt1 or SIRt2 by the first outer power control loop part OLPCb. If the current SIR of a link meets the respective target SIR SIRt1 or SIRt2, the reference quality is equal to the required quality. In this case this link is the only important link. Practically, the reference quality is decreased proportionally to the difference between the target SIR SIRt1 or SIRt2 and the current SIR. As a result, such decentralized mapping avoids too heavy changes in the overall link quality if the combining gain of the frame selection is changing.

[0042] In general, all the above described inventive features can be implemented without the need for undue hardware changes and practically can be even done remotely, in particular via loading or implementing an operating software appropriately adapted to the specific system or network constraints into the base stations and/or radio network controllers, so that no site visits are necessary to implement the features.

[0043] Using such an implemented controlling functionality Fig. 2 is schematically representing an exemplary information flow including a further preferred refinement for managing the distributed outer power control loop OLPCa and OLPCb due to changes in the handling of the radio legs related to the mobile station UE.

[0044] In particular, when a mobile station is locked on a mobile radio communication network or respectively a call creation is performed, firstly the functionality of the outer power control loop part OLPCa of the serving radio network controller SRNC is created and activated, so that the aforementioned process may be performed. Additionally or simultaneously the second outer power control loop part OLPCb of the base station BTS or NodeB to which the mobile station is linked is created and activated so that the respective associated process may be performed.

[0045] If however the at least one radio leg related to the created radio link connection is handled by merely one single base station the second outer power control loop part OLPCa located at the radio network controller is disabled and the entire power is provided for functionality of the first outer power control loop OLPCb of the respective base station. Since there is no reason in such a case for monitoring the quality of the radio bearer from the serving radio network controller SRNC, merely an unnecessary but extra way of signaling delay and hence a control delay between the base station and the radio network controller, as described above, would be introduced. Thus if the at least one radio leg related to the radio connection is handled by one single base station the performance of the system is therefore improved if only the first outer power control loop OLPCb at the base station is operating.

[0046] If a new radio leg is added it is proved whether all of the active radio legs are still supported by the same base station or not. If the actual set of radio legs is still handled by one base station the functionality of the second outer power control loop OLPCa may be still deactivated. If this, however, is not the case, i.e. if the actual set of radio legs is handled by more than one base stations the second outer power control loop OLPCa of the radio network controller RNC is activated so that the first outer power control loop functionality OLPCb and the second outer power control loop functionality OLPCa of the radio network controller RNC run parallel, thereby exchanging information over the lub and/or lur interfaces in order to stay synchronized. Preferably specific information relating to the outer power control loop OLPC in general is firstly transferred to the radio net-

work controller RNC to improving the operating starting process of the second outer power control loop functionality OLPCa of the radio network controller.

[0047] As a consequence, the outer power control loop is then again distributed between the base station and the radio network controller wherein preferably the second outer power control loop OLPCa, located after the frame selector at the serving radio network controller SRNC, provides the master control functionality whilst the means for providing the functionality of the first outer power control loop part OLPCb of the base station has only a restricted decision-power, as described above.

[0048] In case a radio leg is dropped it is again proved if the new set of active legs is supported by the same base station or not. If this is the case then the second outer power control loop OLPCa of the radio network controller is again disabled and the full power in turn is given to the first outer power control loop OLPCb of the base station.

[0049] Consequently by activating or deactivating the second outer power control loop OLPCa of the radio network controller in dependent on whether the radio legs are handled by more than one base station or respectively by a single base station the whole advantages of distributed and centralized outer power control loop architectures are supported by simultaneously optimizing the related signaling traffic between the base station and radio network controllers.

Claims

1. Method for controlling the transmission power in the uplink direction of a CDMA-based radio system comprising

- an inner power control loop (ILPC) adjusting the transmission power (TXpwr) between an user equipment (UE) and at least one base station (NodeB1, NodeB2) based on the signal to interference ratio (SIR) to ensure that the signal to interference ratio (SIR) is similar to a target signal to interference ratio (SIRt1, SIRt2) at least within a predefined range and
- an outer power control loop (OLPC) for adjusting said target signal to interference ratio (SIRt1, SIRt2) based on the link quality (BLER) to ensure a target link quality necessary for fulfilling a predetermined quality of service in view of link quality at least within a predefined range,

wherein the outer power control loop is provided by

- establishing a first outer power control loop (OLPCb) between said at least one base station (NodeB1, NodeB2) and said user equipment (UE) and by
- establishing a second outer power control loop

(OLPCa) between an associated serving radio control means (SRNC) and the at least one base station (NodeB1, NodeB2).

5 2. Method of claim 1, wherein said second outer loop of power control (OLPCa) established between said associated serving radio network controller (SRNC) and the at least one base station (NodeB1, NodeB2) is ensuring the target link quality based on the necessary overall link quality and is providing a reference link quality (BLERref) for the first outer control loop (OLPCb) to enable a predetermined quality of service in view of transmission delay based on retransmission of erroneous signal components.

10 3. Method of claim 1 or 2, wherein said first outer loop of power control (OLPCb) established between said user equipment (UE) and the at least one base station (NodeB1, NodeB2) is adjusting said target signal to interference ratio (SIRt1, SIRt2) such to ensure a reference link quality (BLERref) set by the second outer control loop (OLPCa).

15 4. Method of claim 2 or 3, wherein said first outer power control loop (OLPCb) established between said at least one base station (NodeB1, NodeB2) and said user equipment (UE) is generating said target signal to interference ratio (SIRt1, SIRt2) faster than said second outer power control loop (OLPCa) is generating said reference link quality (BLERref).

20 5. Method of any of the preceding claims, wherein said second outer power control loop (OLPCa) is activated at least based on a soft handover link being a link between said user equipment (UE) and a plurality of base stations (NodeB1, NodeB2) and/or deactivated based on a radio link between said user equipment (UE) and only one base station (NodeB1, NodeB2).

25 6. Method of any preceding claim, wherein a reference link quality (BERref) set by the second outer control loop (OLPCa) is adapted by the first outer power control loop (OLPCb) depending on the difference between the target signal to interference ratio (SIRt1, SIRt2) and the respective current signal to interference ratio to avoid too heavy changes in the overall link quality in particular if the combining gain of frame selection is changing.

30 7. Method of any preceding claim, wherein said first outer power control loop (OLPCb) is restricting said target signal to interference ratio (SIRt1, SIRt2) to a constant value and/or to a value having a predefined increase based on the difference between the target signal to interference ratio (SIRt1, SIRt2) and the current signal to interference ratio (SIR) when

said target signal to interference ratio (SIRt1, SIRt2) is not meet.

8. An UMTS-system adapted to perform the method of any of claims 1 to 7, comprising 5

- means (SRNC) adapted to perform functionality of an outer power control loop (OLPCa) between at least one base station (NodeB1, NodeB2) and an associated serving radio network controller (SRNC) for ensuring an target link quality necessary for fulfilling a predetermined quality of service and 10
- means (NodeB1, NodeB2) for providing functionality of an outer power control loop (OLPCb) between the at least one base station (NodeB1, NodeB2) and at least one user equipment (UE) for adjusting a target signal to interference ratio (SIRt1, SIRt2) according to which said user equipment (UE) is adjusting the uplink transmission power (TXpwr). 15 20

9. A transceiver apparatus, in particular a base transceiver station, having means for adjusting a target signal to interference ratio (SIRt1, SIRt2) based on a reference link quality (BLERref) and adapted to be used for performing the method of any of claims 1 to 7, especially incorporated within a UMTS-system of claim 8. 25 30

10. An implementation software product adapted to perform the method of any of claims 1 to 7, in particular incorporated within a UMTS-system of claim 8. 35

40

45

50

55

8

Fig. 1

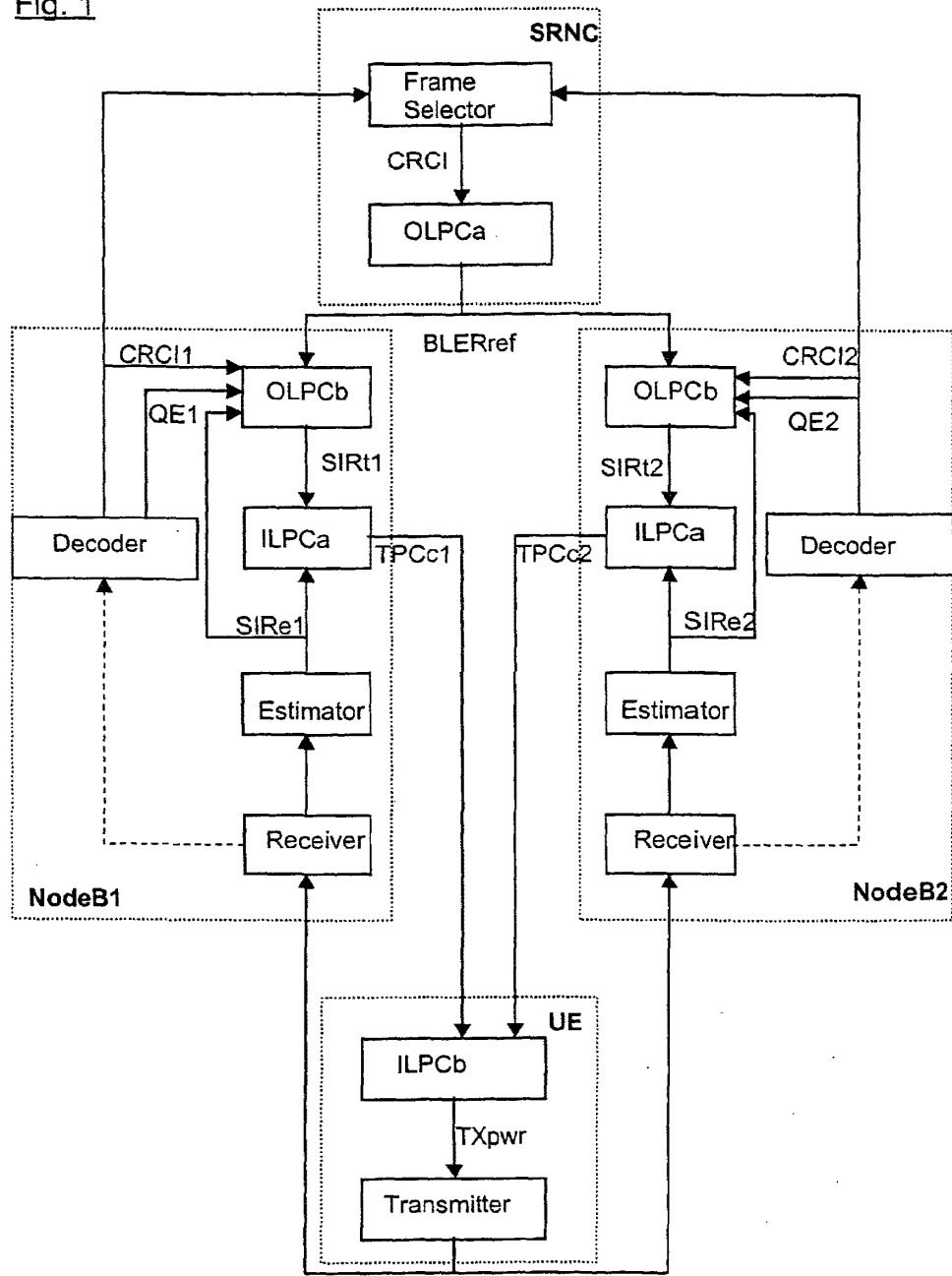

Fig. 2

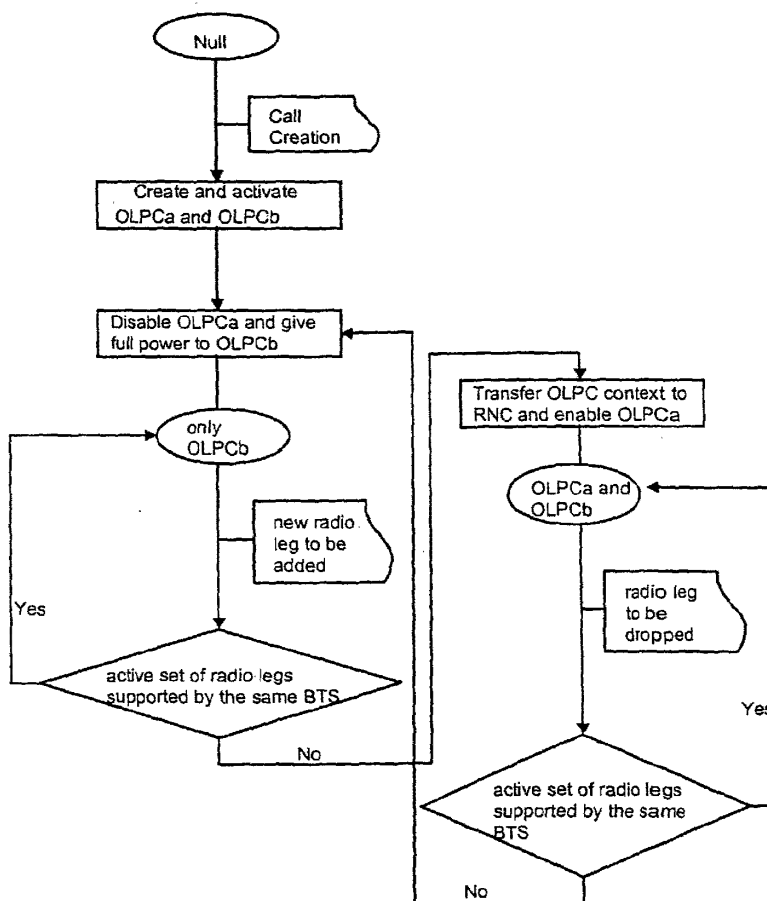
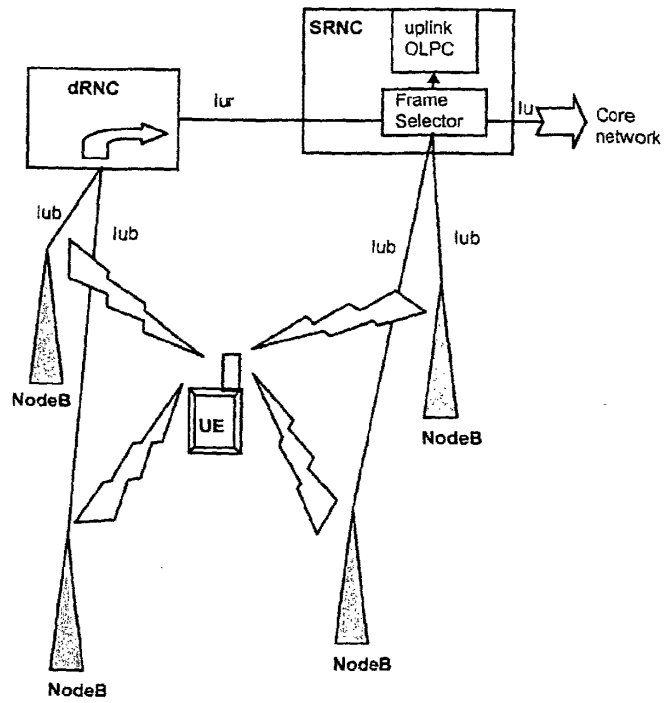

Fig. 3





European Patent Office

EUROPEAN SEARCH REPORT

Application Number
EP 01 30 9520

DOCUMENTS CONSIDERED TO BE RELEVANT			
Category	Citation of document with indication, where appropriate, of relevant passages	Relevant to claim	CLASSIFICATION OF THE APPLICATION (Int.Cl.7)
X	DE 199 30 747 A (SIEMENS AG) 18 January 2001 (2001-01-18) * abstract; claims 1,5; figure 2 * * column 1, line 45 - line 59 * * column 2, line 42 - column 3, line 31 * * column 4, line 20 - line 30 * * column 5, line 9 - line 54 *	1-10	H04B7/005
X	EP 1 054 518 A (CIT ALCATEL) 22 November 2000 (2000-11-22) * column 1, line 9 - line 35 * * column 2, line 5 - line 23 * * column 5, line 50 - line 55 *	1,8-10	
A	US 6 154 659 A (STRAWCZYNSKI LEO ET AL) 28 November 2000 (2000-11-28) * abstract; figure 1 * * column 6, line 32 - line 37 * * column 10, line 53 - line 55 * * column 11, line 23 - line 33 *	1-10	
A	WO 00 35120 A (NOKIA NETWORKS OY ; LONGONI FABIO (FI); SALONAHO OSCAR (FI)) 15 June 2000 (2000-06-15) * abstract; figure 1 * * page 2, line 20 - page 4, line 7 * * page 8, line 8 - page 10, line 13 *	1-10	
			TECHNICAL FIELDS SEARCHED (Int.Cl.7) H04B
The present search report has been drawn up for all claims			
Place of search MUNICH		Date of completion of the search 27 February 2002	Examiner Fribert, J
CATEGORY OF CITED DOCUMENTS X : particularly relevant if taken alone Y : particularly relevant if combined with another document of the same category A : technological background O : non-written disclosure P : intermediate document		T : theory or principle underlying the invention E : earlier patent document, but published on, or after the filing date D : document cited in the application L : document cited for other reasons & : member of the same patent family, corresponding document	

EPO FORM 1503 03.02 (IP/C01)

**ANNEX TO THE EUROPEAN SEARCH REPORT
ON EUROPEAN PATENT APPLICATION NO.**

EP 01 30 9520

This annex lists the patent family members relating to the patent documents cited in the above-mentioned European search report. The members are as contained in the European Patent Office EDP file on
The European Patent Office is in no way liable for these particulars which are merely given for the purpose of information.

27-02-2002

Patent document cited in search report	Publication date	Patent family member(s)	Publication date
DE 19930747 A	18-01-2001	DE 19930747 A1	18-01-2001
EP 1054518 A	22-11-2000	EP 1054518 A1	22-11-2000
		CN 1275039 A	29-11-2000
		JP 2001007761 A	12-01-2001
		US 6341225 B1	22-01-2002
US 6154659 A	28-11-2000	NONE	
WO 0035120 A	15-06-2000	WO 0035120 A1	15-06-2000
		AU 2612899 A	26-06-2000
		BR 9816101 A	05-02-2002
		EP 1135868 A1	26-09-2001
		US 2002019245 A1	14-02-2002

EPC FORM P0459

For more details about this annex : see Official Journal of the European Patent Office, No. 12/82

(19)



Europäisches Patentamt
European Patent Office
Office européen des brevets



(11) EP 1 628 413 A2

(12)

EUROPEAN PATENT APPLICATION

(43) Date of publication:
22.02.2006 Bulletin 2006/08

(51) Int Cl.:
H04B 7/005 (2006.01)

(21) Application number: 05018182.5

(22) Date of filing: 22.08.2005

(84) Designated Contracting States:
AT BE BG CH CY CZ DE DK EE ES FI FR GB GR
HU IE IS IT LI LT LU LV MC NL PL PT RO SE SI
SK TR
Designated Extension States:
AL BA HR MK YU

- Huh, Hoon
Bundang-gu
Sungnam-si
Gyeonggi-do (KR)
- Yoon, Soon-Young
Songpa-gu
Seoul (KR)
- Sung, Sang-Hoon
No. 721-1404, Hyundai APT
Paldal-gu
Suwon-si,
Gyeonggi-do (KR)
- Kwon, Young-Hoon
No. 502-1301,
Bundang-gu
Sungnam-si
Gyeonggi-do (KR)

(30) Priority: 20.08.2004 KR 2004065952

(71) Applicant: SAMSUNG ELECTRONICS CO., LTD.
Suwon-si,
Gyeonggi-do (KR)

- (72) Inventors:
- Cho, Jae-Hee
Yeongdeungpo-gu
Seoul (KR)
 - Hwang, In-Seok
Seoul (KR)
 - Yang, Jang-Hoon
Bundang-gu
Sungnam-si
Gyeonggi-do (KR)

(74) Representative: Grünecker, Kinkeldey,
Stockmair & Schwanhäusser
Anwaltssozietät
Maximilianstrasse 58
80538 München (DE)

(54) **Adaptively changing between closed-loop and open-loop power control based on mobility index**

(57) An apparatus and method for changing an uplink power control scheme according to mobile status in a TDD mobile communication system are provided. A subscriber station transmits to a base station a power control change request message including information about a requested power control scheme. Upon receipt of the power control change request message, the base station selects a power control scheme for the uplink of the sub-

scriber station and transmits to the subscriber station a power control change command message including information about the selected power control scheme. The subscriber station extracts, upon receipt of the power control change command message from the base station, the power control scheme information from the power control change command message and selects a power control scheme according to the extracted information.

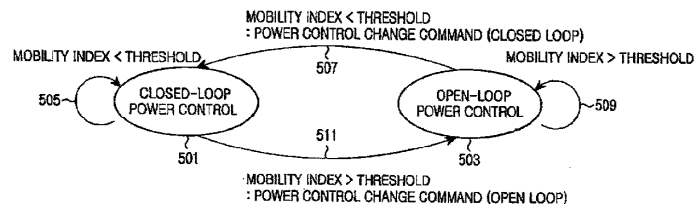

FIG.5

EP 1 628 413 A2

Description**PRIORITY**

5 [0001] This application claims priority under 35 U.S.C. § 119 to an application entitled "Apparatus And Method For Adaptively Changing Uplink Power Control Scheme According To Mobile Status In A TDD Mobile Communication System" filed in the Korean Intellectual Property Office on August 20, 2004 and assigned Serial No. 2004-65952, the contents of which are incorporated herein by reference.

10 BACKGROUND OF THE INVENTION1. Field of the Invention

15 [0002] The present invention relates generally to an apparatus and method for determining a power control scheme in a time division duplex (TDD) mobile communication system, and in particular, to an apparatus and method for changing an uplink power control scheme according to the status of a subscriber station (SS).

2. Description of the Related Art

20 [0003] As one of the duplex schemes, Time Division Duplex (TDD) uses two distinct sets of time slots on the same frequency for the uplink from a base station (BS) to a Subscriber Station (SS) and the downlink from the SS to the BS. Another major duplex scheme is frequency division duplex (FDD). FDD uses two distinct frequencies for the uplink and the downlink.

25 [0004] Unlike FDD, the uplink and the downlink share the same frequency band in TDD and are separated by time slots dedicated to them. That is, time slots are separately preset for the uplink signal and the downlink signal. Therefore, the uplink and downlink signals are transmitted only in their assigned time slots. TDD has the advantage of high frequency use efficiency.

30 [0005] The mobile communication system schedules bursty uplink/downlink packets. Particularly, the BS decides a modulation and coding scheme (MCS) for the resources to be allocated and already allocated resources in uplink/downlink packet scheduling for an SS. An MCS level to be used depends on the status of the SS. For the uplink scheduling, the BS takes into account the maximum transmit power of the SS. Since the transmit power of the SS is restricted to a set level, the BS performs scheduling taking into account the allocated resources, an MCS level to be applied for the resources, and the transmit power limit of the SS. To do so, the scheduler of the BS must have knowledge of the power headroom or transmit power of the SS.

35 [0006] Typically, the mobile communication system uses downlink and uplink power control to increase call capacity and achieve good call quality. That is, if the BS receives a signal from an SS at a signal-to-interference ratio (SIR) that ensures the minimum required call quality by controlling the transmit power of all of the SSs, system capacity can be maximized. In the case where the signal from the SS is received in the BS at a higher power level, the performance of the SS is increased at the expense of increasing interference from other SSs sharing the same channel. As a result, system capacity is decreased or the call quality of other subscribers drops.

40 [0007] Orthogonal Frequency Division Multiplexing (OFDM)/Orthogonal Frequency Division Multiple Access (OFDMA) has recently been proposed as a physical layer scheme for a 4th generation mobile communication system. The above-described power control has also emerged as a challenging issue to the OFDM/OFDMA system.

45 [0008] OFDM/OFDMA is a transmission scheme based on the IEEE 802.16 standard, in which a serial modulation symbol sequence is transmitted as parallel data. OFDM/OFDMA operates in TDD. In OFDM, 256 modulation symbols are Fast-Fourier-Transformed (FFT-processed) to one OFDM symbol, whereas in OFDMA, one OFDM symbol is formed with more modulation symbols. According to the IEEE 802.16-based OFDMA, the subcarriers of one OFDM symbol are grouped into subchannels and a plurality of OFDM symbols form one frame.

50 [0009] FIG. 1 illustrates an OFDMA frame structure specified by IEEE 802.16. The horizontal axis represents OFDM symbol indexes and the vertical axis represents subchannel indexes.

55 [0010] Referring to FIG. 1, an OFDMA frame is comprised of a plurality of bursts each marked by a square on a time-frequency plane. Since the frame is time-division-duplexed, the downlink period and the uplink period can be flexibly controlled. For example, k^{th} through $(k+8)^{\text{th}}$ symbols are allocated to the downlink and $(k+9)^{\text{th}}$ through $(k+12)^{\text{th}}$ symbols are allocated to the uplink, as illustrated in FIG. 1. In the OFDMA frame, a DL/UL MAP burst delivers configuration information (e.g. position, length, and MCS level) about a plurality of downlink/uplink bursts allocated to the frame. The bursts other than the DL/UL MAP burst transfer a DL/UL-Medium Access Control (MAC) layer control message and downlink/uplink data packets. Particularly, the control message bursts can be a power control change request/command message burst for controlling the power control scheme of each SS, or a power control message burst for controlling

the transmit power of each SS. The bursts are time-division-multiple-accessed between SSs and the BS. Transmission gaps called transmit/receive transition gap (TTG) and receive/transmit transition gap (RTG) are inserted between the downlink and uplink periods.

[0011] Meanwhile, each SS performs initial ranging and periodic ranging to correct time and frequency errors in uplink bursts and control power. When the SS attempts ranging, the BS measures the power of a signal from the SS and transmits to the SS a MAC message including a compensation value for signal power loss caused by path attenuation and rapid signal power change.

[0012] Now a description will be made of an uplink power control method in a normal mode in the OFDM/OFDMA TDD system. The uplink power control is executed in two steps.

[0013] In the first step, the BS carries out power control. The BS scheduler determines available resources and an available MCS level for uplink transmission within the transmit power range of an SS of interest by

$$\Delta P = SNR_{req} - SNR_{UL,RX} + (BW_{req} - BW_{RX}) + MARGIN_{TX} \leq Headroom \quad \dots \dots (1)$$

where SNR_{req} and BW_{req} respectively denote the required SNR and bandwidth for applying an MCS level to the current packet to be scheduled. $SNR_{UL,RX}$ and BW_{RX} denote the received SNR and allocated bandwidth of a reference signal, respectively. The reference signal is a previously received uplink burst signal, a data signal or a control signal. $MARGIN_{TX}$ is a term that represents a channel change. That, this margin is set considering the difference between the time of scheduling based on Equation (1) and the actual time of transmitting an uplink signal. Headroom is the transmit power margin of the SS, calculated by subtracting the current transmit power from the maximum transmit power of the SS. The BS is assumed to have knowledge of the maximum transmit power of the SS. ΔP satisfying Equation (1) ensures that the SS transmits an uplink signal with the resources and MCS level scheduled within the limited power.

[0014] In the second step, the SS performs power control. The uplink power control is considered in two ways: closed-loop power control and open-loop power control.

[0015] The uplink closed power control is a scheme of controlling the transmit power of the SS according to a command from the BS. The BS notifies the SS of a required power increment/decrement ΔP as well as the resources and MCS level scheduled by Equation (1).

[0016] The uplink open-loop power control is a scheme of deciding the uplink transmit power in the SS itself. The BS simply tells the SS the resources and MCS level decided by Equation (1) and the SS then computes the uplink transmit power of an uplink signal to be transmitted using the allocated resources by

$$\begin{aligned} P &= PL_{UL} + SNR_{req} + NI_{UL,RX} + BW_{req} + MARGIN_{RX} \\ &= PL_{DL} + SNR_{req} + NI_{UL,RX} + BW_{req} + MARGIN_{RX} \\ &= PL_{DL,TX} - PL_{DL,RX} + SNR_{req} + NI_{UL,RX} + BW_{req} + MARGIN_{RX} \end{aligned} \quad \dots \dots (2)$$

where PL_{UL} and PL_{DL} denote uplink and downlink path losses, respectively. In view of the TDD system, these two values are almost the same. The SS can estimate PL_{DL} using the transmit power of the BS, $P_{DL,TX}$ and the downlink received power $P_{DL,RX}$ of the SS. $NI_{UL,RX}$ is the power of a signal and interference measured at a receiver of the BS, common to all of the SSs. SNR_{req} and BW_{req} respectively denote the required SNR and bandwidth for an MCS level to be applied to a packet. $MARGIN_{RX}$ is a term that represents the difference between the time to which Equation (2) is computed for application and the actual uplink transmission time.

[0017] FIG. 2 is a diagram illustrating a signal flow for a conventional closed-loop power control.

[0018] Referring to FIG. 2, the SS transmits a reference signal and information about the uplink transmit power of the reference signal ($UL_Tx, Power$) in an uplink burst to the BS in step 201.

[0019] In step 203, the BS (scheduler) calculates the received SNR of the reference signal and determines resources, an MCS level, and a power increment ΔP for the SS by Equation (1). Headroom involved in Equation (1) can be calculated using the information of the transmit power ($UL_Tx, Power$).

[0020] In step 205, the BS allocates the uplink resources to the SS according to the scheduling (UL_MAP) and transmits a power control command (or the power increment) to the SS. The resource assignment (UL_MAP) information is delivered in a UL-MAP burst and the power control command is set in a DL burst containing a predetermined control message.

5 [0021] The SS determines its uplink transmit power according to the power control command in step 207 and transmits packets using the allocated resources in step 209. Thereafter, step 203 (BS scheduling) through step 209 (uplink transmission) are repeated.

[0022] As described before, the power control command is selectively transmitted in the closed-loop power control. Only if the channel status is changed and the SNR of an uplink received signal is changed, does the BS transmit a power control command to the SS. In the absence of the power control command, the SS determines its uplink transmit power based on the previous uplink transmit power by

$$15 \quad P_{new} = P_{Last} + SNR_{New} - SNR_{Last} + (BW_{New} - BW_{Last}) \quad \dots \dots (3)$$

20 where P_{new} and P_{Last} denote the new transmit power and the previous transmit power, respectively, SNR_{New} and SNR_{Last} denote a required new SNR and the previous required SNR, respectively, and BW_{New} and BW_{Last} denote a new allocated SNR and the previous allocated SNR, respectively.

[0023] FIG. 3 is a diagram illustrating a signal flow for a conventional open-loop power control.

25 [0024] Referring to FIG. 3, the SS transmits a reference signal and information about the uplink transmit power of the reference signal (UL_Tx, Power) in an uplink burst to the BS in step 301.

[0025] In step 303, the BS (scheduler) calculates the received SNR of the reference signal and determines resources, an MCS level, and a power increment ΔP for the SS by Equation (1). Headroom involved in Equation (1) can be calculated using the information of the transmit power (UL_Tx, Power).

30 [0026] In step 305, the BS allocates the uplink resources to the SS according to the scheduling (UL_MAP) and transmits the uplink resource assignment (UL_MAP) information to the SS. Compared to the closed-loop power control, a power control command is not transmitted in the open-loop power control. Instead, the BS broadcasts in a DL-MAP burst $P_{DL,TX}$ and $N_{UL,RX}$ necessary for the computation of Equation (2) to all of the SSs.

35 [0027] The SS determines its uplink transmit power using the resource assignment information by Equation (2) in step 307 and transmits an uplink signal using the allocated resources in step 309. At the same time, the SS tells the BS the current transmit power. Thereafter, step 303 (BS scheduling) through step 309 (uplink transmission) are repeated.

40 [0028] As described earlier, in contrast to the closed-loop power control, the open-loop power control scheme provide to the BS information about the current uplink transmit power along with the uplink transmission because the SS can change the uplink transmit power freely. Equation (2) that the SS uses in deciding the transmit power includes a channel variation which is not known to the BS and thus the headroom of the SS is changed, unnoticed by the BS. Therefore, the SS tells the BS the current transmit power at every uplink transmission so that the BS can update the headroom.

45 [0029] On the other hand, in the closed-loop power control, the transmit power of the SS is changed by a power control command from the BS or a transmit power calculation formula (Equation (3)) known to the BS. Accordingly, the BS can distinguish a transmit power change from a channel change in the SNR estimate of an uplink signal. That is, the BS can execute a power control taking the channel change into account, as shown in Equation (1). The headroom can also be calculated using the previous headroom and the previous power control command or using the transmit power of the SS that the bas station can estimate by Equation (3). Consequently, the SS does not need to notify the BS of its transmit power at every uplink transmission in the closed-loop power control.

[0030] The features of the two power control schemes are summarized below in Table 1.

50

Table 1

	Closed-loop power control	Open-loop power control
Downlink feedback	Power control command	$P_{DL,TX}$, $N_{UL,RX}$
Uplink feedback	none	Uplink transmit power
Scheduling margin	$MARGIN_{TX}$	$MARGIN_{TX}$
Maximum transmit power margin	$MARGIN_{TX}$	$MARGIN_{RX}$

55

[0031] As noted from Table 1, the closed-loop and open-loop power control schemes differ in uplink/downlink feedback, scheduling margin, and maximum transmit power margin. The uplink/downlink feedback has been described before. The scheduling margin is $MARGIN_{TX}$ in both power control schemes because a scheduling time point coincides with an actual uplink transmission time in them. The maximum transmit power margin is defined as the maximum difference between a required transmit power satisfying SNR_{req} at the receiver and an actual transmit power. For the closed-loop power control, the maximum transmit power margin is $MARGIN_{TX}$ since the actual transmit power is decided at scheduling. For the open-loop power control, the actual transmit power is decided by Equation (2) and thus the maximum transmit power margin is $MARGIN_{RX}$. The scheduling margin leads to resource assignment loss, and the maximum transmit power margin results in an increase in total system interference.

[0032] If the SS moves slowly, the closed-loop power control performs better on the whole. Because the channel does not change much at a low mobile velocity, the power control command is not issued frequently and thus the amount of downlink feedback information is small. $MARGIN_{TX}$ affected by the channel variation is also very small. Also, the scheduling is done and the transmit power is decided according to the actual uplink channel status, as in Equation (1). Therefore, the uplink power control can be performed with high reliability.

[0033] On the contrary, if the SS moves fast, the open-loop power control outperforms the closed-loop power control. The channel changes greatly at a high mobile velocity and thus the number of occurrences of the power control command in the closed-loop power control is approximately equal to the number of transmit power feedbacks in the open-loop power control. However, because $MARGIN_{TX} \geq MARGIN_{RX}$, the closed-loop power control tracks the channel variation consuming much resources, or cannot track the channel variation at all. As a result, the closed-loop power control causes greater interference than the open-loop power control in the case where the SS moves fast.

SUMMARY OF THE INVENTION

[0034] As described above, the closed-loop and open-loop power control schemes offer their benefits according to the velocity of the mobile terminal. Nevertheless, conventional systems adopt only one of the two power control schemes. In another case, the open-loop power control applies to an initial access, and the closed-loop power control applies thereafter. Thus, the conventional systems do not fully utilize the advantages of the closed-loop and open-loop power control schemes.

[0035] An object of the present invention is to substantially solve at least the above problems and/or disadvantages and to provide at least the advantages below. Accordingly, an object of the present invention is to provide an apparatus and method for adaptively determining a power control scheme according to mobile velocity in a mobile communication system.

[0036] Another object of the present invention is to provide an apparatus and method for adaptively determining a power control scheme according to mobile velocity in an OFDM/OFDMA TDD mobile communication system.

[0037] The above objects are achieved by providing an apparatus and method for adaptively changing an uplink power control scheme according to mobile status in a TDD mobile communication system.

[0038] According to an aspect of the present invention, in a base station in a mobile communication system supporting a plurality of uplink power control schemes, a mobility estimator generates a mobility index by estimating the velocity of a subscriber station, and a power controller selects a power control scheme for the uplink of a subscriber station from among the plurality of power control schemes by comparing the mobility index with a threshold.

[0039] According to another aspect of the present invention, in a subscriber station device in a mobile communication system supporting a plurality of power control schemes, a MAC entity extracts, upon receipt of a power control change command message from a base station, information about a power control scheme requested by the base station from the power control change command message, and a power controller selects a power control scheme according to the extracted information received from the MAC entity and determines the transmit power of an uplink burst according to the selected power control scheme.

[0040] According to a further aspect of the present invention, in a method of determining an uplink power control scheme in a mobile communication system supporting a plurality of uplink power control schemes, a base station selects a power control scheme for the uplink of a subscriber station according to the status of the subscriber station and transmits to the subscriber station a power control change command message including information about the selected power control scheme. The subscriber station extracts, upon receipt of the power control change command message from the base station, the power control scheme information from the power control change command message and selects a power control scheme according to the extracted information.

[0041] According to still another aspect of the present invention, in a method of determining an uplink power control scheme in a mobile communication system supporting a plurality of uplink power control schemes, a subscriber station transmits to a base station a power control change request message including information about a requested power control scheme. The base station selects, upon receipt of the power control change request message, a power control scheme for the uplink of the subscriber station and transmits a power control change command message including

information about the selected power control scheme to the subscriber station. The subscriber station extracts, upon receipt of the power control change command message from the base station, the power control scheme information from the power control change command message and selects a power control scheme according to the information extracted by the subscriber station.

5 [0042] According to yet another aspect of the present invention, in a method of determining an uplink power control scheme in a mobile communication system supporting a plurality of uplink power control schemes, a base station generates a mobility index by estimating the velocity of a subscriber station, selects a power control scheme for the uplink of a subscriber station according to the mobility index, and transmits to the subscriber station a power control change command message including information about the selected power control scheme, if the selected power control
10 scheme is different from a previous power control scheme.

[0043] According to yet further aspect of the present invention, in a method of determining an uplink power control scheme in a mobile communication system supporting a plurality of power control schemes, a subscriber station extracts from the power control change command message, upon receipt of a power control change command message from a base station, information about a power control scheme requested by the base station, selects a power control scheme
15 according to the extracted information, and determines the transmit power of an uplink burst according to the selected power control scheme.

BRIEF DESCRIPTION OF THE DRAWINGS

20 [0044] The above and other objects, features and advantages of the present invention will become more apparent from the following detailed description when taken in conjunction with the accompanying drawings in which:

FIG. 1 illustrates an OFDMA uplink/downlink frame structure in an IEEE 802.16 OFDMA system;
FIG. 2 is a diagram illustrating a signal flow for a conventional closed-loop power control;
25 FIG. 3 is a diagram illustrating a signal flow for a conventional open-loop power control;
FIG. 4 is a block diagram of a BS in a TDD communication system according to an embodiment of the present invention;
FIG. 5 is a diagram illustrating power control state transitions of the BS depending on which power control scheme is selected in the TDD communication system according to an embodiment of the present invention;
30 FIG. 6 is a flowchart illustrating an operation for determining an uplink power control scheme in the BS in the TDD communication system according to an embodiment of the present invention;
FIG. 7 is a block diagram of an SS in the TDD communication system according to an embodiment of the present invention;
FIG. 8 is a diagram illustrating power control state transition of the SS depending on which power control scheme is selected in the TDD communication system according to an embodiment of the present invention;
35 FIG. 9 is a flowchart illustrating an operation for determining an uplink power control scheme in the SS in the TDD communication system according to an embodiment of the present invention;
FIG. 10 is a flowchart illustrating an operation for requesting a power control change to the BS in the SS in the TDD communication system according to an embodiment of the present invention; and
40 FIG. 11 is a diagram illustrating a flow of messages exchanged between the BS and the SS in the TDD communication system according to an embodiment of the present invention.

DETAILED DESCRIPTION OF THE PREFERRED EMBODIMENTS

45 [0045] Preferred embodiments of the present invention will be described herein below with reference to the accompanying drawings. In the following description, well-known functions or constructions are not described in detail since they would obscure the invention in unnecessary detail.

[0046] The present invention is intended to provide an apparatus and method for selecting a closed-loop power control scheme or an open-loop power control scheme for uplink power control according to mobile status in a mobile communication system. While the present invention will be described in the context of an IEEE 802.16e communication system, for the sake of convenience, the power control scheme changing method of the present invention is applicable to all other Time Division Duplex (TDD) communication systems.

[0047] FIG. 4 is a block diagram of a BS in a TDD communication system according to an embodiment of the present invention. The BS includes a MAC entity 401 connected to a higher layer, a TDD transmission MODEM 403, a TDD
50 reception MODEM 405, a duplexer 407, an uplink power controller 409, a mobility estimator 411, and a scheduler 413.

[0048] Referring to FIG. 4, the MAC entity 401 receives transmission data from the higher layer and processes the received data in compliance with the connection protocol of the TDD transmission MODEM 403. The MAC entity 401 receives data from the TDD reception MODEM 405, processes the received data in compliance with the connection

protocol of the higher layer, and provides the processed data to the higher layer.

[0049] The TDD transmission MODEM 403, which includes a channel encoder, a modulator, and an RF transmission unit, converts the data received from the MAC entity 401 to a form suitable for radio transmission. The modulator performs spreading in a code division multiple access (CDMA) communication system, and OFDM modulation (IFFT) in an OFDM communication system.

[0050] The TDD reception MODEM 405, which includes an RF reception unit, a demodulator, and a channel decoder, recovers a radio signal received from the duplexer 407, and provides the recovered signal to the MAC entity 401.

[0051] The duplexer 407 provides a signal received in TDD from an antenna (uplink signal) to the TDD reception MODEM 405, and provides the transmission signal received from the TDD transmission MODEM 403 (downlink signal) to the antenna.

[0052] The scheduler 413 schedules uplink and downlink data transmission according to data transmission status and the channel statuses of the individual SSs, and orders the Subscriber Station (SS)s to transmit and receive data as scheduled. In an IEEE 802.16 communication system, for example, the scheduler 413 generates UL-MAP and DL-MAP as uplink and downlink configuration information, and the MAC entity 401 receives an uplink signal and transmits a downlink signal according to the UL-MAP and DL-MAP from the scheduler 413.

[0053] The mobility estimator 411 determines a mobility index by estimating the mobility status of an individual SS from a radio signal received from the SS. Many mobility status estimation algorithms are available and any one of them can be assumed to be used herein. In accordance with the embodiment of the present invention, a higher mobility index indicates a higher mobile velocity.

[0054] The uplink power controller 409 is responsible for the closed-loop or open-loop power control. It determines the resources and an MCS level available to each mobile terminal in a predetermined method (e.g. Equation (1)) and tells the scheduler 413 the determined resources and the MCS level. In the case of the closed-loop power control, the uplink power controller 409 generates a power control command for an individual SS to the MAC entity 401. The power control schemes have been described in detail and their description is not provided herein.

[0055] In accordance with the present invention, the uplink power controller 409 determines a power control scheme for the SS based on the mobility index received from the mobility estimator 411. This determination can be made every set time period or upon receipt from the SS of a power control change request. If the power control scheme is changed for the SS, the uplink power controller 409 provides to the MAC entity 401 a power control command for the SS. The MAC entity generates a power control change command message according to the power control change command and provides it to the TDD transmission MODEM 403.

[0056] FIG. 5 is a diagram illustrating power control state transitions of the BS depending on which power control scheme is selected in the TDD communication system according to an embodiment of the present invention.

[0057] Referring to FIG. 5, a status variable called power control mode change (PMC) is used in deciding a power control scheme. If PMC is '0', it indicates selection of the closed-loop power control. If the PMC is '1', it indicates selection of the open-loop power control.

[0058] In the state where PMC=0, if the mobility index received from the mobility estimator 411 is less than a threshold, the state PMC=0 is kept, as indicated by reference numeral 505. If the mobility index is greater than the threshold, the state PMC=0 is transitioned to the state PMC=1, as indicated by reference numeral 511. Similarly, in the state where PMC=1, if the mobility index is greater than the threshold, the state PMC=1 is kept, as indicated by reference numeral 509. If the mobility index is less than the threshold, the state PMC=1 is transitioned to the state PMC=0, as indicated by reference numeral 507. If the PMC value is changed, this implies that a different power control scheme from the previous one has been selected. Thus, a power control change command is transmitted to the SS, notifying the SS of the change of the power control scheme.

[0059] With reference to the state transition diagram of FIG. 5, the operation of the BS will be described below.

[0060] FIG. 6 is a flowchart illustrating an operation for determining in the BS an uplink power control scheme in the TDD communication system according to an embodiment of the present invention. As stated before, a decision can be made as to which power control scheme is to be used at a set time period or upon receipt of a power control change request from the SS. These two methods can also be used in combination. The following description is made under the assumption that the decision is made periodically.

[0061] Referring to FIG. 6, the BS determines if a predetermined time period has elapsed and thus if it is time to set a power control scheme in step 601. If it is time to set a power control scheme, the mobility estimator 411 compares a calculated mobility index with the threshold in step 603. In step 605, the BS compares the mobility index with the threshold. If the mobility index is less than the threshold, the BS sets PMC to 0 in step 607. Since the mobility index being less than the threshold means that the SS moves slowly, the power control scheme is set to the closed-loop power control. On the contrary, if the mobility index is greater than the threshold, the BS sets PMC to 1 in step 609. Since the mobility index being greater than the threshold means that the SS moves fast, the power control scheme is set to the open-loop power control.

[0062] In step 611, the BS determines if the PMC has been toggled by comparing the power control scheme set

currently with the previous power control scheme. If PMC has not been changed, the BS returns to step 601. If PMC has been changed, the BS transmits to the SS a power control change command message including information the changed power control scheme in step 613 and returns to step 601. The detailed structure of the power control change command message is illustrated below in Table 3.

5 [0063] As described above, the BS decides whether to change the power control scheme and the SS changes its power control scheme only by the power control change command received from the BS.

[0064] FIG. 7 is a block diagram of the SS in the TDD communication system according to an embodiment of the present invention.

10 [0065] The SS of the present invention includes a MAC entity 701 connected to a higher layer, a TDD transmission MODEM 703, a TDD reception MODEM 705, a duplexer 707, a power controller 709, and a mobility estimator 711.

[0066] Referring to FIG. 7, the MAC entity 701 receives transmission data from the higher layer and processes the received data in compliance with the connection protocol of the TDD transmission MODEM 703. The MAC entity 701 receives data from the TDD reception MODEM 705, processes the received data in compliance with the connection protocol of the higher layer, and provides the processed data to the higher layer. The functions of the MAC entity 701 are performed as commanded by the BS scheduler 413. In the IEEE 802.16 communication system, for example, the scheduler 413 generates UL-MAP and DL-MAP as uplink and downlink configuration information, and the MAC entity 701 of the SS receives a downlink signal and transmits an uplink signal according to the DL-MAP and UL-MAP received from the scheduler 413.

15 [0067] The TDD transmission MODEM 703, which includes a channel encoder, a modulator, and an RF transmission unit, converts the data received from the MAC entity 701 to a form suitable for radio transmission. Particularly, the TDD transmission MODEM 703 adjusts the transmit power of the uplink signal according to an uplink transmit power value received from the power controller 709.

20 [0068] The TDD reception MODEM 705, which includes an RF unit, a demodulator, and a channel decoder, recovers a radio signal received from the duplexer 707, and provides the recovered signal to the MAC entity 701. The duplexer 707 provides a signal received in TDD from an antenna (downlink signal) to the TDD reception MODEM 705, and provides the transmission signal received from the TDD transmission MODEM 703 (uplink signal) to the antenna.

25 [0069] The mobility estimator 711 determines a mobility index by estimating the mobility status of the SS from a radio downlink signal received from the BS, and provides the mobility index to the power controller 709. Many mobility status estimation algorithms are available and any one of them can be used herein. In accordance with the embodiment of the present invention, it is assumed that a higher mobility index indicates a higher mobile velocity.

30 [0070] The power controller 709 is responsible for the closed-loop or open-loop power control. For the closed-loop power control, the power controller 709 determines uplink transmit power according to a power control command received from the BS or by Equation (3), and provides the uplink power transmit power value to the TDD transmission MODEM 703. For the open-loop power control, the power controller 709 determines the uplink transmit power by Equation (2) and provides it to the TDD transmission MODEM 703. In the case of calculating the uplink transmit power by Equation (2) or Equation (3), information about required bandwidth and SNR is acquired from the resource assignment information (UL-MAP) received from the BS. These power control schemes have been described before in detail and their description is not provided herein.

35 [0071] In accordance with the present invention, the power controller 709 adaptively selects a power control scheme according to the power control change command received from the BS. To be more specific, the power control change command message is provided to the MAC entity 701 through the TDD transmission MODEM 705. The MAC entity 701 extracts a power control change command indicating a power control scheme from the message. The power controller 709 then selects a power control scheme according to the power control change command received from the MAC entity 701.

40 [0072] The power controller 709 can request changing the uplink power control scheme to the BS. Specifically, the power controller 709 selects a power control scheme according to the mobility index received from the mobility estimator 711 and if the selected power control scheme is different from the previous one, the power controller 709 transmits the power control change request to the MAC entity 701. Thus the MAC entity 701 generates a power control change request message and transmits it to the BS. In this way, the SS only needs to request the change of a power control scheme and the BS makes a final decision about the power control scheme.

45 [0073] FIG. 8 is a diagram illustrating power control state transition of the SS depending on which power control scheme is selected in the TDD communication system according to an embodiment of the present invention.

[0074] Referring to FIG. 8, PMC is used in deciding a power control scheme. If PMC is '0', it indicates selection of the closed-loop power control. If the PMC is '1', it indicates selection of the open-loop power control.

50 [0075] In the state where PMC=0, if the power control change command received from the BS indicates the closed-loop power control, the state PMC=0 (closed-loop power control) is kept, as indicated by reference numeral 805. If the power control change command indicates the open-loop power control, the state PMC=0 is transitioned to the state PMC=1 (open-loop power control), as indicated by reference numeral 811. Similarly, in the state where PMC=1, if the power

control change command indicates the open-loop power control, the state PMC=1 (open-loop power control) is kept, as indicated by reference numeral 809. If the power control change command indicates the closed-loop power control, the state PMC=1 is transitioned to the state PMC=0 (closed-loop power control), as indicated by reference numeral 807. In this way, the SS determines the power control scheme according to the power control change command from the BS.

5 [0076] With reference to the state transition diagram of FIG. 8, the operation of the SS will be described below.

[0077] FIG. 9 is a flowchart illustrating an operation for determining an uplink power control scheme in the SS in the TDD communication system according to an embodiment of the present invention.

[0078] Referring to FIG. 9, the SS determines if a power control change command message has been received from the BS in step 901. Upon receipt of the power control change command message, the SS checks in step 903 a power control change command set in the message. In step 905, the SS determines if the power control change command indicates the closed-loop power control. If it does, the SS sets PMC to 0 (closed-loop power control) in step 907 and returns to step 901. If the power control change command indicates the open-loop power control, the SS sets the PMC to 1 (open-loop power control) in step 909 and returns to step 901.

10 [0079] FIG. 10 is a flowchart illustrating an operation for requesting a power control change to the BS in the SS in the TDD communication system according to an embodiment of the present invention.

[0080] Referring to FIG. 10, the SS compares a mobility index calculated by the mobility estimator 711 with a predetermined threshold in step 1001 and determines if the mobility index is less than the threshold in step 1003. If the mobility index is less than the threshold, the SS sets PMC to 0 (closed-loop power control) in step 1005. Since the mobility index being less than the threshold means that the SS moves slowly, the power control scheme is set to the closed-loop power control. On the contrary, if the mobility index is greater than the threshold, the SS sets PMC to 1 (open-loop power control) in step 1007. Since the mobility index being greater than the threshold means that the SS moves fast, the power control scheme is set to the open-loop power control.

[0081] In step 1009, the SS determines if PMC has been toggled by comparing the power control scheme set currently (PMC') with the previous power control scheme (PMC). If PMC has not been changed, the SS returns to step 1001. If PMC has been changed, the SS transmits to the BS a power control change request message including information about the changed power control scheme in step 1011 and returns to step 1001. The detailed structure of the power control change request message is illustrated below in Table 2.

15 [0082] FIG. 11 is a diagram illustrating a flow of messages exchanged between the BS and the SS in the TDD communication system according to an embodiment of the present invention. Particularly, the messages are used in the process of requesting changing by the SS a power control scheme to the BS and determining a power control scheme upon receipt of the power control change request by the BS.

[0083] Referring to FIG. 11, when it is necessary to change a power control scheme, the SS transmits to the BS in step 1101 a power control change request message including information about a requested power control scheme. The format of the power control change request message is illustrated below in Table 2.

20 [0084] Upon receipt of the power control change request message, the BS determines a power control scheme based on the mobility index of the SS in step 1103. If the determined power control scheme is different from the previous one, the BS transmits to the SS in step 1105 a power control change command message including information about the determined power control scheme. The format of the power control change command message is illustrated below in Table 3.

25 [0085] Upon receipt of the power control change command message, the SS sets in step 1107 a power control scheme according to a power control change command set in the received message.

[0086] As described above, the SS requests the change of a power control scheme and the BS transmits a power control change command to the SS in response to the power control change request. In another case, the BS can transmit the power control change command according to the mobility index to the SS, without receiving the power control change request. The power control change request message is transmitted to the BS in a UL burst and the power control change command message is transmitted to the SS in a DL burst, as illustrated in FIG. 1. Configuration information about the UL burst and the DL burst are delivered to the SS in a UL-MAP burst and a DL-MAP burst. That is, the SS transmits the power control change request message and receives the power control change command message using the MAP information received from the BS.

30 [0087] Table 2 below illustrates an example of the power control change request message depicted in FIG. 11, which can be transmitted from the SS in the IEEE 802.16 communication system. It is delivered to the BS in a UL burst.

Table 2

Syntax	Size	Notes
PMC_REQ message format{		
Management Message Type=62	8 bits	Type=62

EP 1 628 413 A2

Table continued

Syntax	Size	Notes
Power control mode change	1 bit	0: Closed-loop power control mode 1: Open-loop power control mode
UL Tx power	8 bits	UL Tx power level for the burst that carries this header (11.1.1). When the Tx power is different from slot to slot, the maximum value is reported
Reserved	7 bits	
}		

[0088] Referring to Table 2, "Management Message Type" is a serial number that identifies the message in the IEEE 802.16 communication system. It can be changed according to a system standardization. "Power control mode change" indicates a requested power control scheme. It is set to '0' for the closed-loop power control and to '1' for the open-loop power control. "UL Tx power" indicates the transmit power value of the uplink burst that delivers the power control change request. Encoding of the transmit power value is performed in compliance with IEEE 802.16, which will not be described in detail herein. The BS can utilize the transmit power value for power control, set in the uplink burst with the power control change request. "Reserved" represents bits inserted to match the total size of the message in bytes.

[0089] Table 3 below illustrates an example of the power control change command message depicted in FIG. 11, which can be transmitted from the BS in the IEEE 802.16 communication system. It is delivered to the base mobile in a DL burst.

Table 3

Syntax	Size	Notes
PMC_RSP message format{		
Management Message Type=63	8 bits	Type=63
Power control mode change	1 bit	0: Closed-loop power control mode 1: Open-loop power control mode
Start frame	3 bits	3 LSBs of frame number when the indicated power control mode is activated
If (Power control mode change=0)	7 bits	
Power adjust	8 bits	Signed integer, which expresses the change in power level (in multiples of 0.25dB) that the SS shall apply to its current transmission power. When subchannelization is employed, the subscriber shall interpret the power offset adjustment as a required change to the transmitted power density
else		
Offset _{perSS}	8 bits	Signed integer, which expresses the change in power level (in multiples of 0.2dB) that the SS shall apply to the open-loop power control formula in 8.4.10.3.1.
Reserved	4 bits	
}		

[0090] Referring to Table 3, "Management Message Type" is a serial number that identifies the message in the IEEE 802.16 communication system. It can be changed according to a system standardization. "Power control mode change" indicates a requested power control scheme. It is set to '0' for the closed-loop power control and to '1' for the open-loop power control. "Start frame" indicates a frame in which the indicated power control scheme starts to be applied in the IEEE 802.16 communication system. If the indicated power control scheme is the closed-loop power control, a power control command "Power adjust" about the transmit power of the SS is transmitted. In the case of the open-loop power control, an offset value "Offset_{perSS}" is transmitted to be reflected in MARGIN_{RX} of Equation (2). This offset value is specific to the SS, like the change of link performance caused by channel selectivity and the diversity gain of BS antennas. In this case, MARGIN_{RX} reflects the channel status of the SS as well as the time delay until the power control scheme is applied.

[0091] Table 4 below illustrates an example of a bandwidth request and uplink transmit power report message that

EP 1 628 413 A2

can be transmitted by the SS in the IEEE 802.16 communication system.

Table 4

5	MSB																		
	HT= 1(0)	EC= 1 (0)	Type(3) =011	BR(11)															
	UL Tx Power (8)								CID MSB (8)										
10	CID LSB (8)								HCS (8)										

[0092] Referring to Table 4, the bandwidth request and uplink transmit power report message is a modification to an existing IEEE 802.16 bandwidth request message. In general, uplink communications starts with a bandwidth request from the SS in the IEEE 802.16 communication system. Thus, the bandwidth request message was defined in the IEEE 802.16 communication system. Assuming that the uplink communications start with the bandwidth request from the SS, an uplink message transmitted from the SS when the procedure illustrated in FIG. 2 or FIG. 3 can be the bandwidth request message. Yet, this message cannot be used as a reference signal for power control in the procedure because it does not have information about uplink transmit power. Accordingly, the SS transmits a bandwidth request and an uplink transmit power value together in the present invention. In this context, the bandwidth request and uplink transmit power report message illustrated in Table 4 is designed to serve as the reference signal for power control. Particularly, this message is in a control message format called a header according to IEEE 802.16.

[0093] In Table 4, "HT (Header Type)" indicates a header type. It is set to '1' all the time. "EC (Encryption Control)" indicates if the payload following the header is encrypted or not. "EC" is always set to '1'. The bandwidth request and uplink transmit power report message is configured to have a header only, without payload. "Type" indicates the type of the bandwidth request header. It can be changed according to standardization. "BR" is short for Bandwidth Request. It indicates the amount of uplink data in bytes. "UL Tx Power" indicates the transmit power value of a UL burst that carries the bandwidth request and uplink transmit power report message. Encoding of the transmit power value performed in compliance with IEEE 802.16, and its description will not be provided herein. The BS can utilize the transmit power for power control transmit, set in the uplink burst with the bandwidth request and uplink transmit power report message. "CID (Connection ID)" is a 16-bit IEEE 802.16 connection ID. "HCS (Header Check Sequence)" is a 8-bit cyclic redundancy check (CRC) value for the message, to be used for error detection in the BS. The CRC operation is based on IEEE 802.16 and its description will not be provided herein.

[0094] In accordance with the present invention as described above, an uplink power control scheme is changed in a TDD communication system. Therefore, the uplink power control can be carried out more efficiently. That is, an efficient uplink power control is provided by fully utilizing the advantages of the closed-loop and open-loop power control schemes.

[0095] While the invention has been shown and described with reference to certain preferred embodiments thereof, they are merely exemplary applications. For example, while the closed-loop power control and the open-loop power control have been described as available power control schemes, the present invention is applicable to further-divided power control schemes. Therefore, it will be understood by those skilled in the art that various changes in form and details may be made therein without departing from the spirit and scope of the invention as defined by the appended claims.

Claims

1. A base station device in a mobile communication system supporting at least two uplink power control schemes, comprising:
 - a mobility estimator for generating a mobility index by estimating the velocity of a subscriber station; and
 - a power controller for selecting a power control scheme for the uplink of a subscriber station from among the at least two power control schemes by comparing the mobility index with a threshold.
2. The base station device of claim 1, wherein the power controller selects an open-loop power control scheme if the mobility index is greater than the threshold, and selects a closed-loop power control scheme if the mobility index is less than the threshold.
3. The base station device of claim 1, further comprising a medium access control (MAC) entity for generating a power control change command message to be transmitted to the subscriber station, if the selected power control scheme

is different from a previous power control scheme.

4. The base station device of claim 3, wherein the power control change command message includes a Power control mode change field indicating a requested power control scheme, a Start Frame field indicating the start time of applying the indicated power control scheme, a Power adjust field indicating a power control command about the transmit power of the subscriber station if the indicated power control scheme is the closed-loop power control scheme, and an $\text{Offset}_{\text{perSS}}$ field indicating a margin which is set taking into account the different between a point in time when the transmit power of the subscriber station is calculated and an actual uplink transmission point in time if the indicated power control scheme is the open-loop power control scheme.
5. The base station device of claim 1, wherein the power controller selects a power control scheme periodically or upon receipt of a power control change request message from the subscriber station.
6. The base station device of claim 5, wherein the power control change request message includes a Power control mode change field indicating a power control scheme requested by the subscriber station, and a UL Tx Power field indicating the transmit power of an uplink burst that carries the power control change request message.
7. The base station device of claim 1, wherein the mobile communication system is orthogonal frequency division multiplexing/ orthogonal frequency division multiple access-time division duplex (OFDM/OFDMA-TDD) communication system.
8. A subscriber station device in a mobile communication system supporting at least two power control schemes, comprising:
 - a medium access control (MAC) entity for, upon receipt of a power control change command message from a base station, extracting information about a power control scheme requested by the base station from the power control change command message; and
 - a power controller for selecting a power control scheme according to the extracted information received from the MAC entity and determining the transmit power of an uplink burst according to the selected power control scheme.
9. The subscriber station device of claim 8, wherein the power control change command message includes a Power control mode change field indicating the power control scheme requested by the base station, a Start Frame field indicating the start time of applying the indicated power control scheme, a Power adjust field indicating a power control command about the transmit power of a subscriber station if the indicated power control scheme is a closed-loop power control scheme, and an $\text{Offset}_{\text{perSS}}$ field indicating a margin which is set taking into account the different between a point in time when the transmit power of the subscriber station is calculated and an actual uplink transmission point in time if the indicated power control scheme is an open-loop power control scheme.
10. The subscriber station device of claim 8, further comprising a mobility estimator for generating a mobility index by estimating the velocity of the subscriber station, wherein the power controller selects the open-loop power control scheme if the mobility index is greater than a threshold, and selects the closed-loop power control scheme if the mobility index is less than the threshold, and wherein the MAC entity generates a power control change request message to be transmitted to the base station, if the selected power control scheme is different from a previous power control scheme.
11. The subscriber station device of claim 10, wherein the power control change request message includes a Power control mode change field indicating a power control scheme requested by the subscriber station, and a UL Tx Power field indicating the transmit power of an uplink burst that carries the power control change request message.
12. The subscriber station device of claim 8, wherein if the subscriber station requests a bandwidth to the base station, the MAC entity generates a bandwidth request message including information about transmit power.
13. The subscriber station device of claim 12, wherein the bandwidth request message includes a Bandwidth Request (BR) field indicating the amount of uplink data to be transmitted and a UL Tx Power field indicating the transmit power of an uplink burst that carries the bandwidth request message.
14. The subscriber station device of claim 8, wherein the mobile communication system is orthogonal frequency division

multiplexing/ orthogonal frequency division multiple access-time division duplex (OFDM/OFDMA-TDD) communication system.

- 5 **15.** A method of adaptively determining an uplink power control scheme in a mobile communication system supporting at least two uplink power control schemes, comprising the steps of:
- (1) deciding by a base station a power control scheme for the uplink of a subscriber station according to the status of the subscriber station;
- 10 (2) transmitting to the subscriber station by the base station a power control change command message including information about the selected power control scheme; and
- (3) extracting by the subscriber station, upon receipt of the power control change command message from the base station, the power control scheme information from the power control change command message and selecting by the subscriber station a power control scheme according to the extracted information.
- 15 **16.** The method of claim 15, wherein step (1) is performed periodically.
- 17.** The method of claim 15, wherein step (1) comprises the step of selecting the power control scheme for the uplink of the subscriber station by comparing a mobility index indicating the velocity of the subscriber station with a threshold.
- 20 **18.** The method of claim 15, wherein step (2) comprises the steps of:
- comparing the selected power control scheme with a previous power control scheme; and
- transmitting to the subscriber station the power control command message with the power control scheme information, if the selected power control scheme is different from the previous power control scheme.
- 25 **19.** The method of claim 15, wherein the power control change command message includes a Power control mode change field indicating the power control scheme requested by the base station, a Start Frame field indicating the start time of applying the indicated power control scheme, a Power adjust field indicating a power control command about the transmit power of the subscriber station if the indicated power control scheme is a closed-loop power control scheme, and an $\text{Offset}_{\text{perSS}}$ field indicating a margin which is set taking into account the different between
- 30 a point in time when the transmit power of the subscriber station is calculated and an actual uplink transmission point in time if the indicated power control scheme is an open-loop power control scheme.
- 20.** A method of adaptively determining an uplink power control scheme in a mobile communication system supporting at least two uplink power control schemes, comprising the steps of:
- 35 (a) transmitting to a base station by a subscriber station a power control change request message including information about a requested power control scheme;
- (b) deciding by the base station, upon receipt of the power control change request message, a power control scheme for the uplink of the subscriber station;
- 40 (c) transmitting to the subscriber station by the base station a power control change command message including information about the selected power control scheme; and
- (d) extracting by the subscriber station, upon receipt of the power control change command message from the base station, the power control scheme information from the power control change command message and selecting by the subscriber station a power control scheme according to the extracted information.
- 45 **21.** The method of claim 20, further comprising the step of determining by the subscriber station whether to change a power control scheme based on the velocity of the subscriber station.
- 50 **22.** The method of claim 20, wherein step (b) comprises the step of selecting the power control scheme for the uplink of the subscriber station by comparing a mobility index indicating the velocity of the subscriber station with a threshold.
- 23.** The method of claim 20, wherein step (c) comprises the steps of:
- 55 comparing the selected power control scheme with a previous power control scheme; and
- transmitting to the subscriber station the power control command message with the power control scheme information, if the selected power control scheme is different from the previous power control scheme.

24. The method of claim 20, wherein the power control change request message includes a Power control mode change field indicating a power control scheme requested by the subscriber station, and a UL Tx Power field indicating the transmit power of an uplink burst that carries the power control change request message.
- 5 25. The method of claim 20, wherein the power control change command message includes a Power control mode change field indicating the power control scheme requested by the base station, a Start Frame field indicating the start time of applying the indicated power control scheme, a Power adjust field indicating a power control command about the transmit power of the subscriber station if the indicated power control scheme is a closed-loop power control scheme, and an $\text{Offset}_{\text{perSS}}$ field indicating a margin which is set taking into account the different between
10 a point in time when the transmit power of the subscriber station is calculated and an actual uplink transmission point in time if the indicated power control scheme is an open-loop power control scheme.
26. A method of determining an uplink power control scheme in a base station in a mobile communication system supporting at least two uplink power control schemes, comprising the steps of:
15
generating a mobility index by estimating the velocity of a subscriber station;
deciding a power control scheme for the uplink of a subscriber station according to the mobility index; and
transmitting to the subscriber station a power control change command message including information about the selected power control scheme, if the selected power control scheme is different from a previous power control scheme.
20
27. The method of claim 26, wherein the power control scheme selecting step is performed periodically or upon request from the subscriber station.
- 25 28. The method of claim 26, wherein the power control change command message includes a Power control mode change field indicating the power control scheme requested by the base station, a Start Frame field indicating the start time of applying the indicated power control scheme, a Power adjust field indicating a power control command about the transmit power of the subscriber station if the indicated power control scheme is a closed-loop power control scheme, and an $\text{Offset}_{\text{perSS}}$ field indicating a margin which is set taking into account the different between
30 a point in time when the transmit power of the subscriber station is calculated and an actual uplink transmission point in time if the indicated power control scheme is an open-loop power control scheme.
29. A method of determining an uplink power control scheme in a subscriber station in a mobile communication system supporting at least two power control schemes, comprising the steps of:
35
extracting, upon receipt of a power control change command message from a base station, information about a power control scheme requested by the base station from the power control change command message;
deciding a power control scheme according to the extracted information; and
determining the transmit power of an uplink burst according to the selected power control scheme.
40
30. The method of claim 29, wherein the power control change command message includes a Power control mode change field indicating the power control scheme requested by the base station, a Start Frame field indicating the start time of applying the indicated power control scheme, a Power adjust field indicating a power control command about the transmit power of a subscriber station if the indicated power control scheme is a closed-loop power control scheme, and an $\text{Offset}_{\text{perSS}}$ field indicating a margin which is set taking into account the different between a point
45 in time when the transmit power of the subscriber station is calculated and an actual uplink transmission point in time if the indicated power control scheme is an open-loop power control scheme.
31. The method of claim 29, further comprising the steps of:
50
determining the uplink power control scheme according to the status of the subscriber station; and
transmitting to the base station a power control change request message, if the determined power control scheme is different from a previous power control scheme.
- 55 32. The method of claim 31, wherein the power control change request message includes a Power control mode change field indicating the power control scheme requested by the subscriber station, and a UL Tx Power field indicating the transmit power of an uplink burst that carries the power control change request message.

EP 1 628 413 A2

33. A method of determining an uplink power control mode in a broadband wireless communication system supporting an open loop power control and a closed loop power control, comprising the steps of:

5 transmitting a power control change request message from a subscriber station (SS) to base station (BS) to
change the power control mode;
deciding by the BS of the change of the power control mode between the open loop power control and closed
loop power control; and
10 transmitting a power control change response message from the BS to the SS including the decided power
control mode.

10

15

20

25

30

35

40

45

50

55

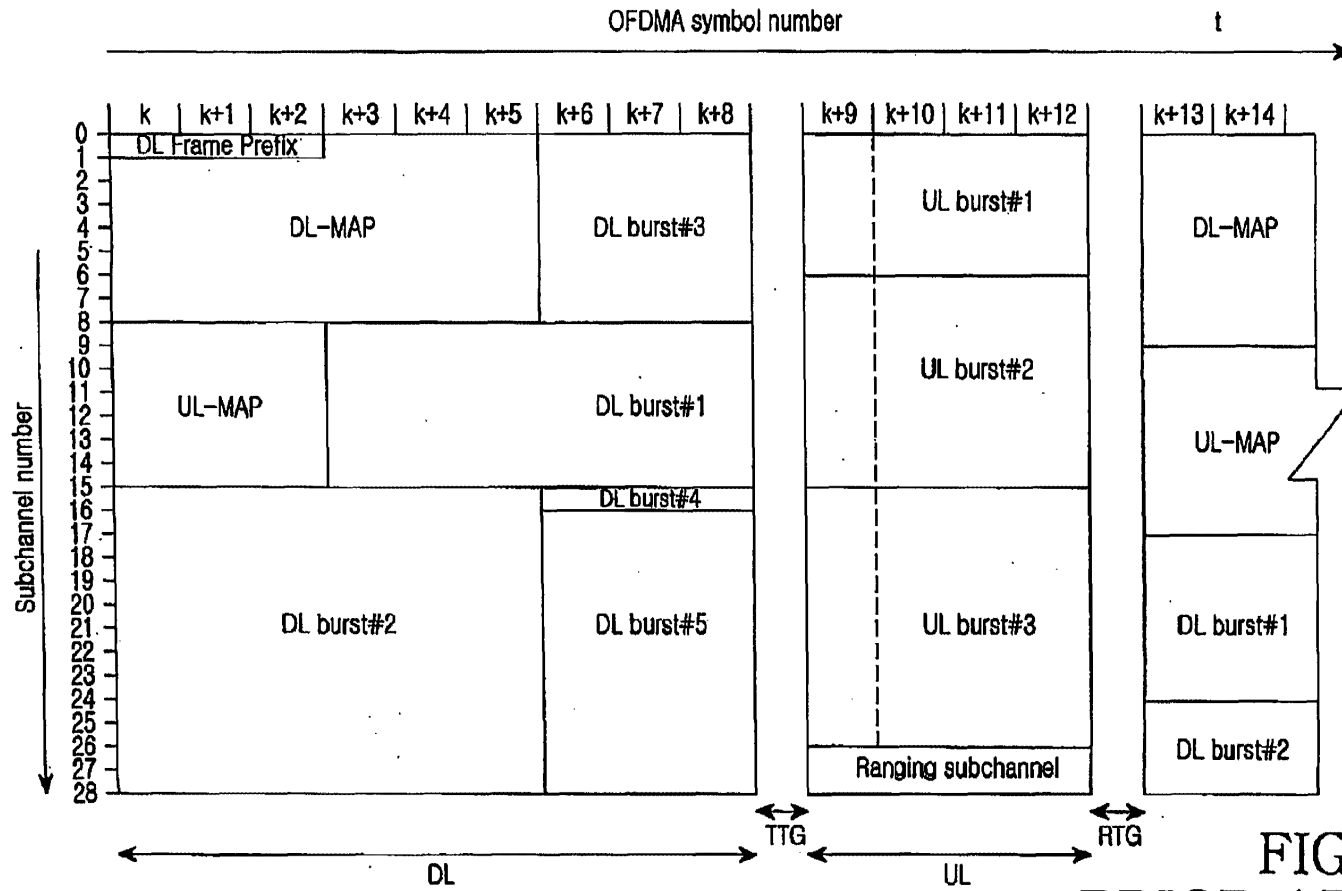

EP 1 628 413 A2

FIG.1
PRIOR ART

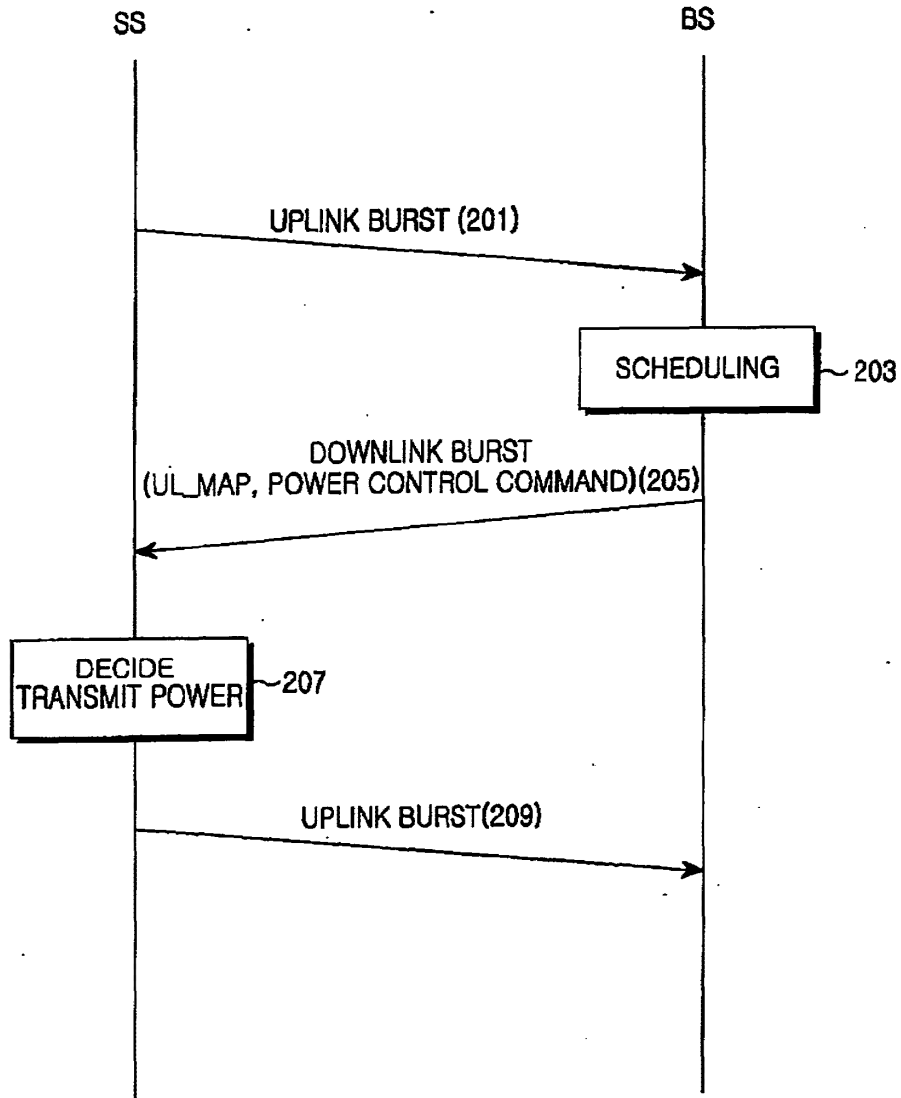

FIG.2
PRIOR ART

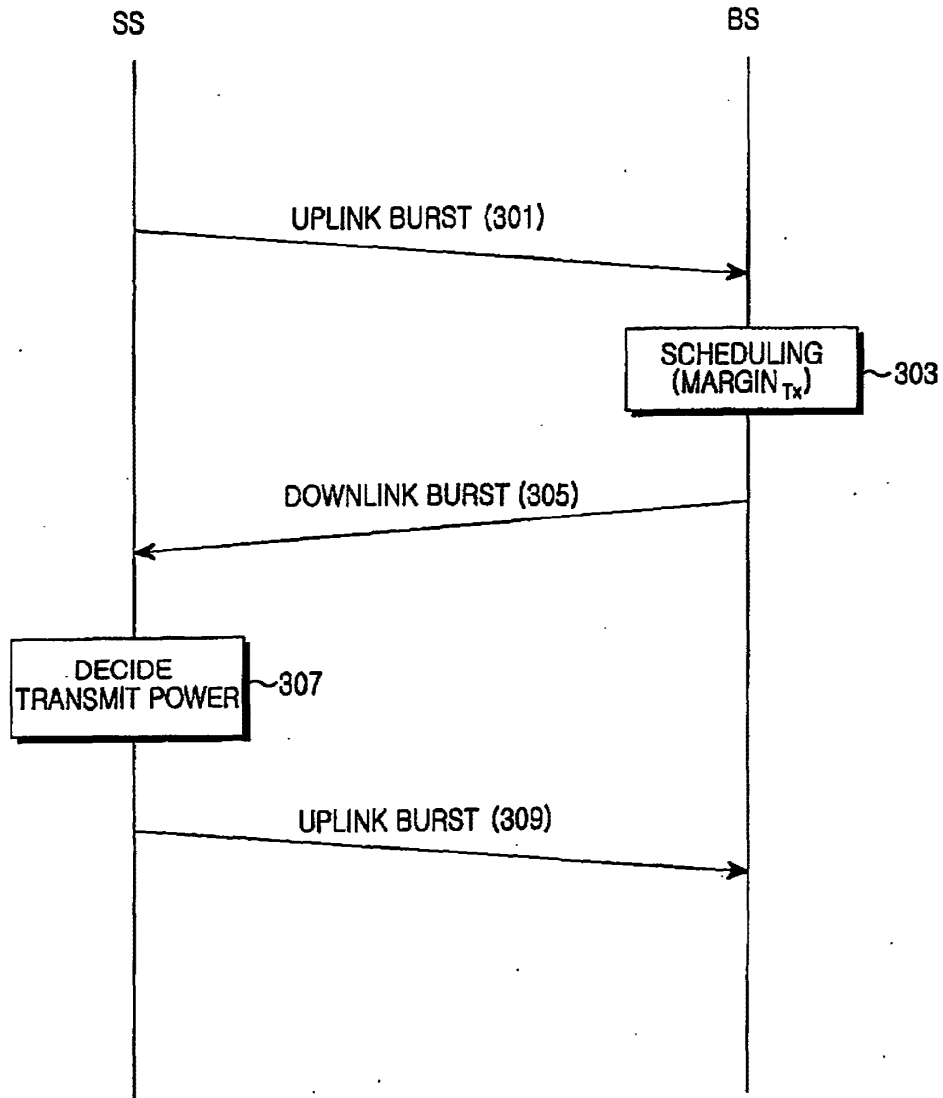

FIG.3
PRIOR ART

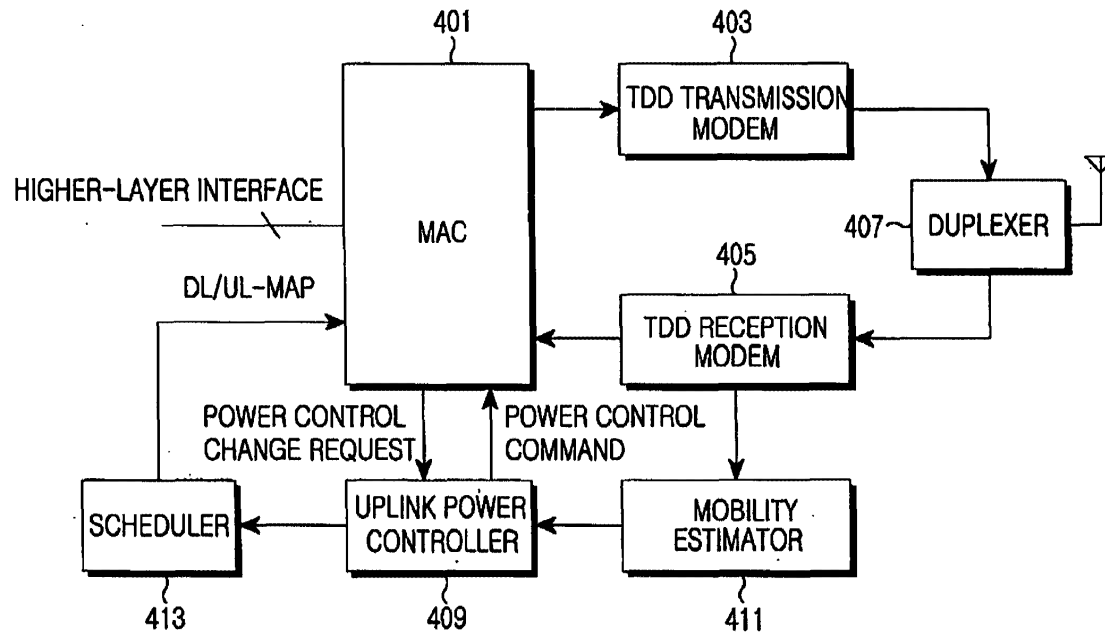

FIG.4

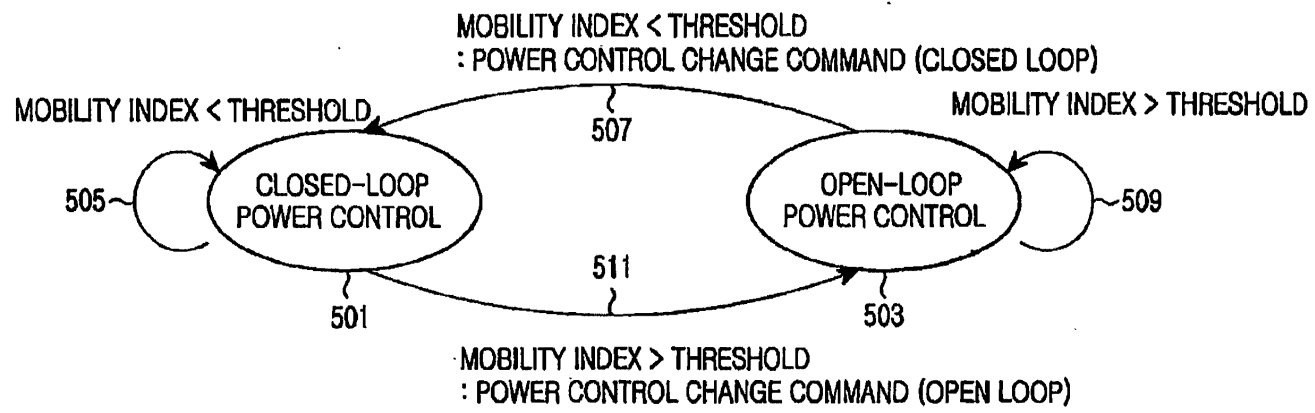

FIG.5

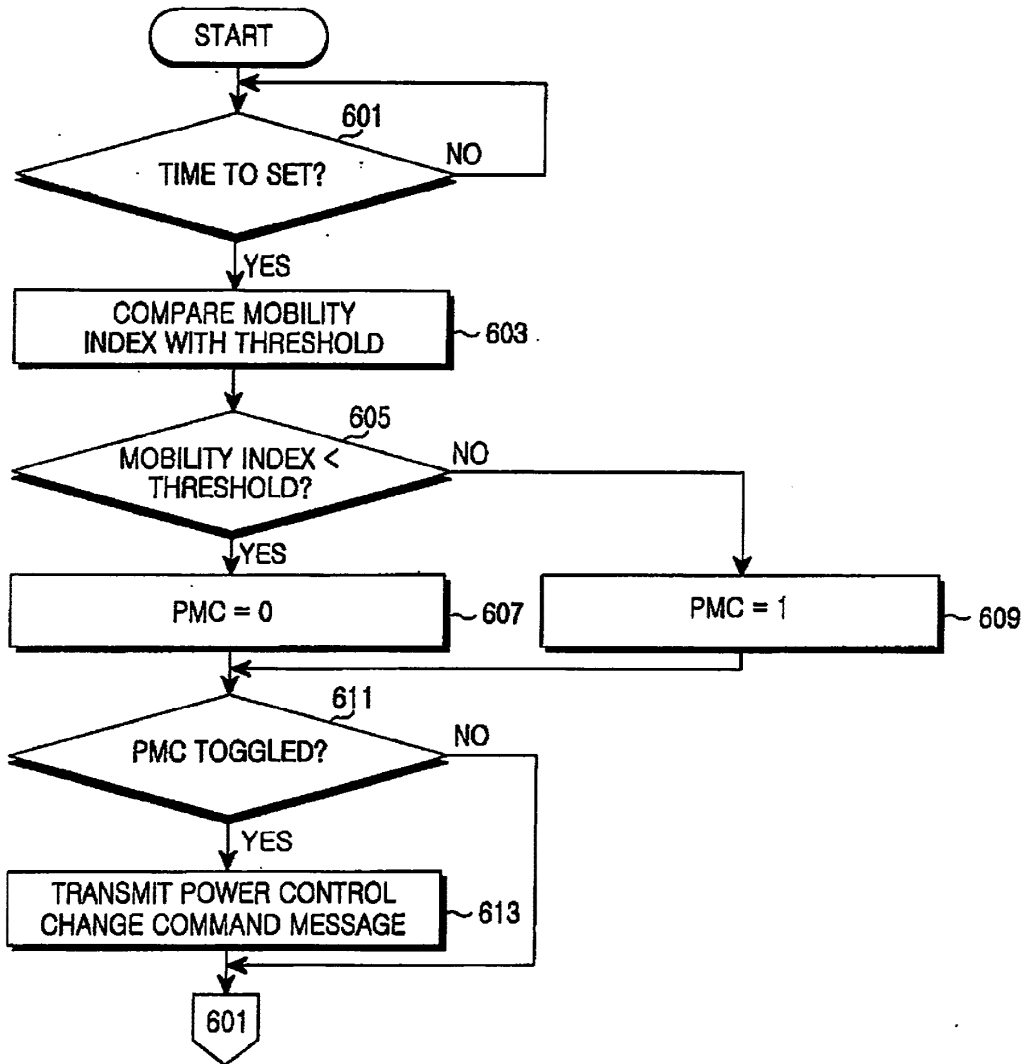

FIG.6

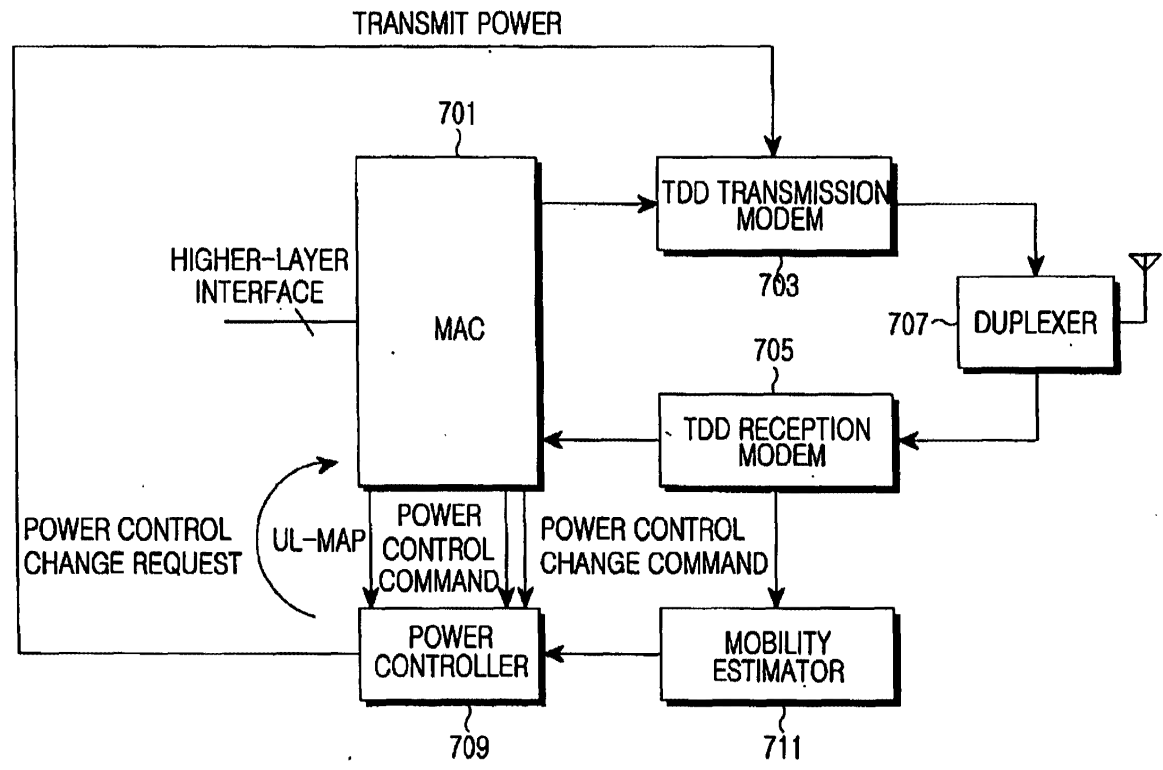

FIG.7

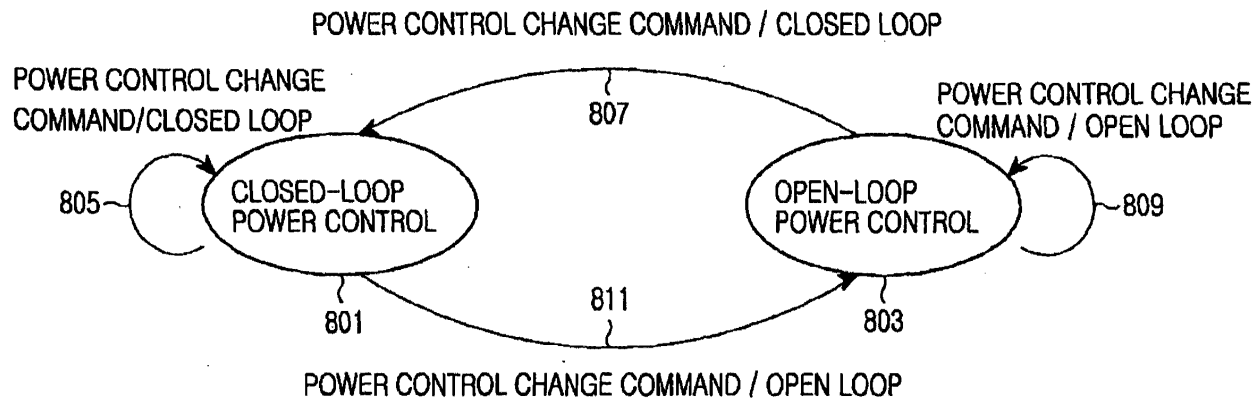

FIG.8

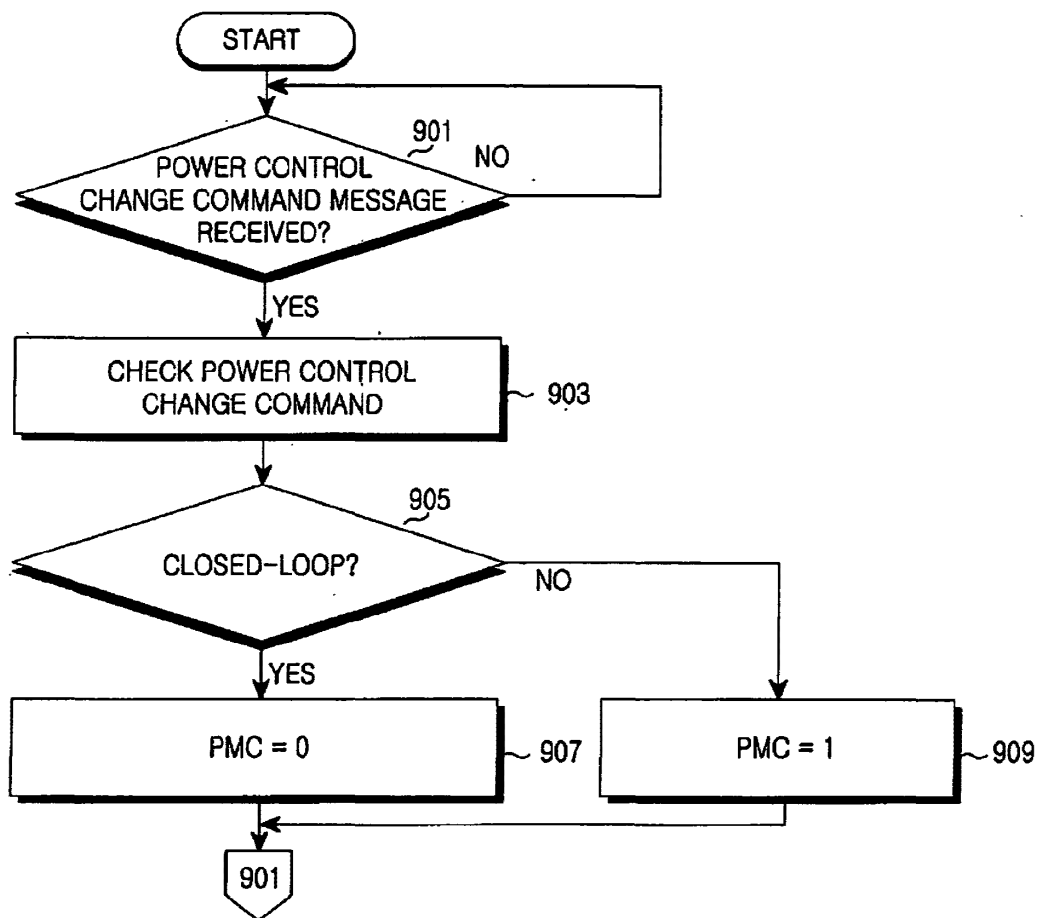

FIG.9

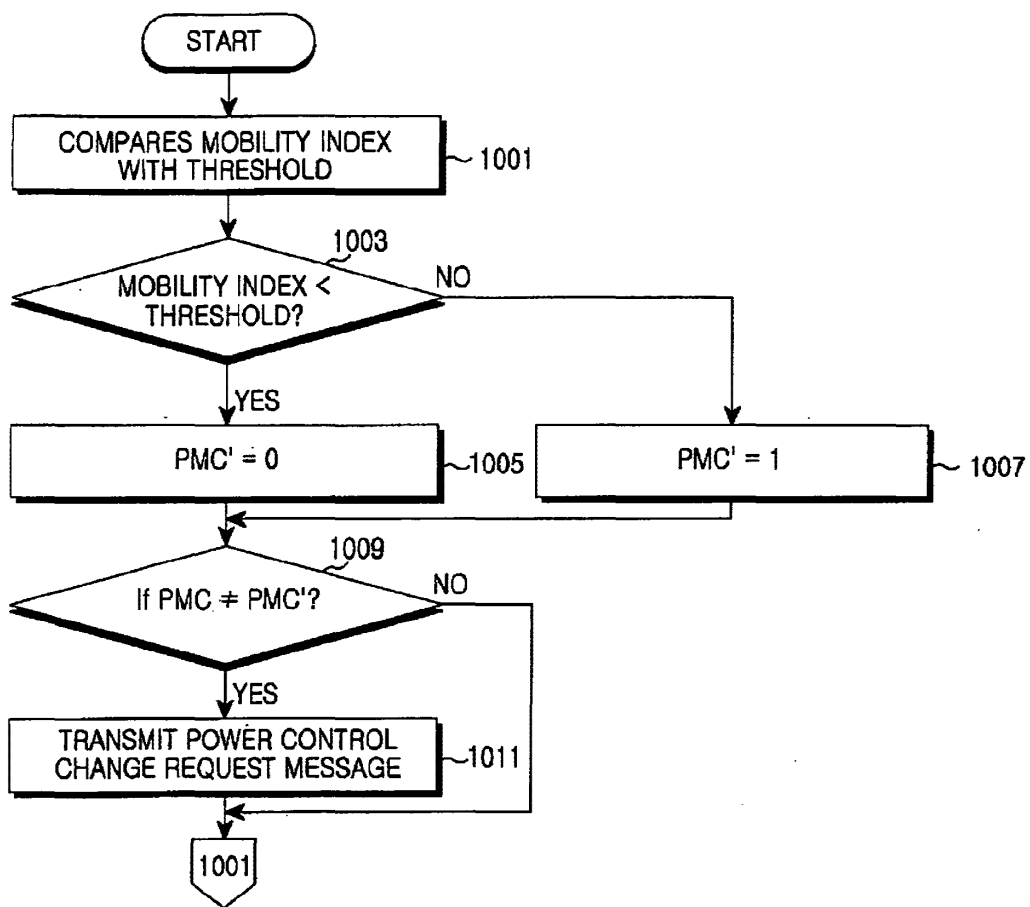

FIG. 10

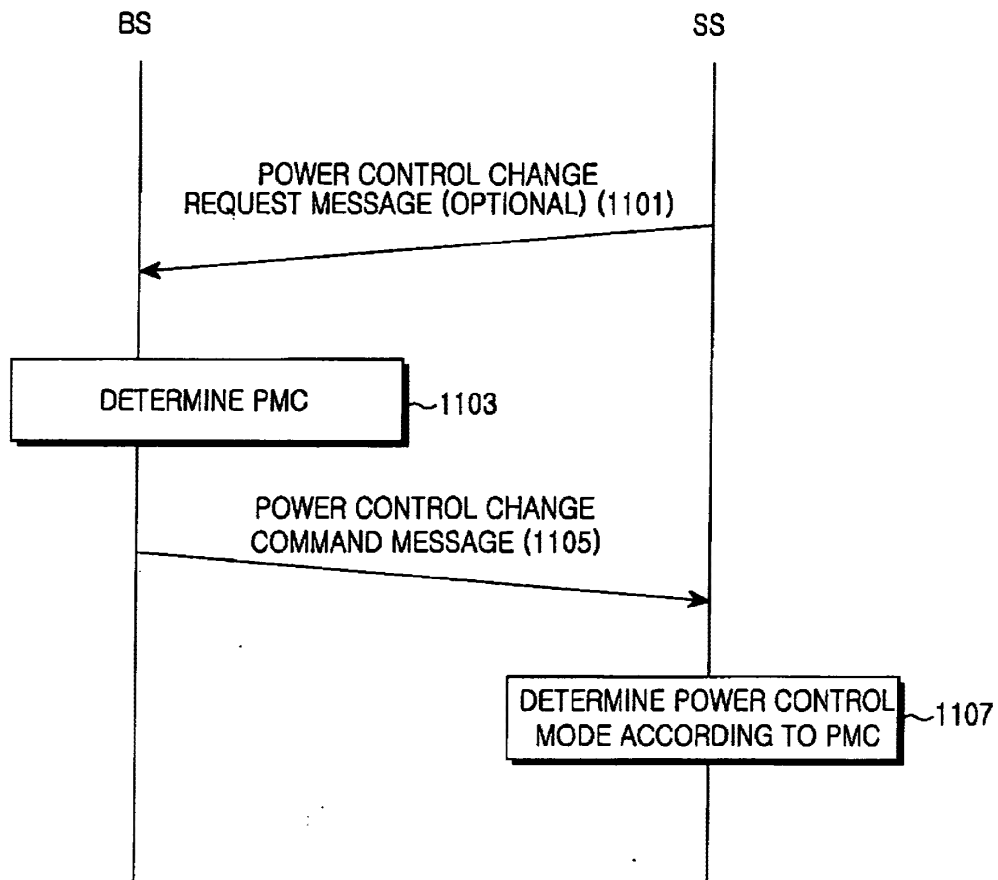

FIG.11



INTERNATIONAL APPLICATION PUBLISHED UNDER THE PATENT COOPERATION TREATY (PCT)

<p>(51) International Patent Classification ⁷ : H04B 7/216</p>	<p>A1</p>	<p>(11) International Publication Number: WO 00/03499 (43) International Publication Date: 20 January 2000 (20.01.00)</p>
<p>(21) International Application Number: PCT/KR99/00372 (22) International Filing Date: 13 July 1999 (13.07.99) (30) Priority Data: 1998/28238 13 July 1998 (13.07.98) KR 1998/32351 5 August 1998 (05.08.98) KR (71) Applicant: SAMSUNG ELECTRONICS CO., LTD. [KR/KR]; 416, Maetan-dong, Paldal-gu, Suwon-shi, Kyungki-do 442-370 (KR). (72) Inventors: KIM, Young-Ky; Sunkyoung Apt., 12-1401, Taechi-dong, Kangnam-gu, Seoul 135-280 (KR). AHN, Jae-Min; Puleun Samho Apt., 109-303, Irwonpon-dong, Kangnam-gu, Seoul 135-239 (KR). PARK, Chang-Soo; 72-2, Munjong-dong, Songpa-gu, Seoul 138-202 (KR). (74) Agent: LEE, Keon-Joo; Mihwa Building, 110-2, Myon- gryun-dong 4-Ga, Chongro-gu, Seoul 110-524 (KR).</p>		<p>(81) Designated States: AE, AL, AM, AT, AU, AZ, BA, BB, BG, BR, BY, CA, CH, CN, CU, CZ, DE, DK, EE, ES, FI, GB, GD, GE, GH, GM, HR, HU, ID, IL, IS, JP, KE, KG, KP, KR, KZ, LC, LK, LR, LS, LT, LU, LV, MD, MG, MK, MN, MW, MX, NO, NZ, PL, PT, RO, RU, SD, SE, SG, SI, SK, SL, TJ, TM, TR, TT, UA, UG, UZ, VN, YU, ZA, ZW, European patent (AT, BE, CH, CY, DE, DK, ES, FI, FR, GB, GR, IE, IT, LU, MC, NL, PT, SE). Published <i>With international search report. Before the expiration of the time limit for amending the claims and to be republished in the event of the receipt of amendments.</i></p>

(54) Title: POWER CONTROL DEVICE AND METHOD FOR REVERSE LINK COMMON CHANNEL IN MOBILE COMMUNICATION SYSTEM

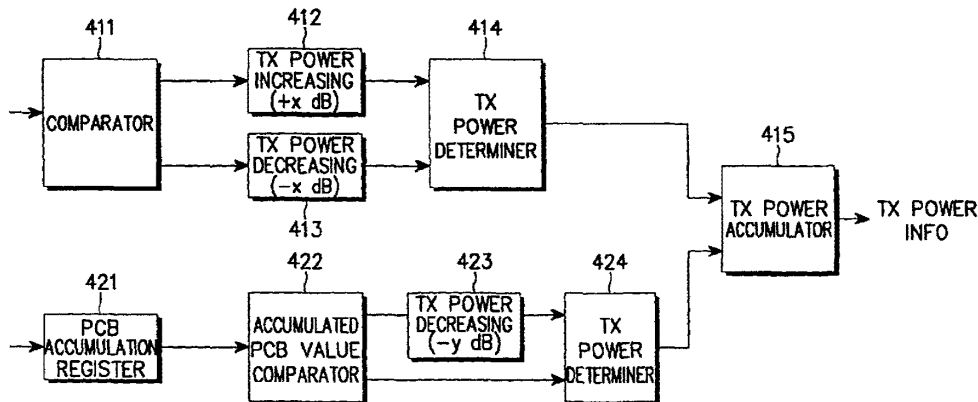

(57) Abstract

A method for controlling the transmission power of the reverse common channel for a mobile station in a CDMA communication system. In the method, the mobile station transmits a preamble signal at predetermined periods with increasing transmission power. Upon receipt of an acknowledge signal from a base station, the mobile station accesses the reverse common channel. In order to avoid multiple mobile stations from simultaneously generating increasingly powerful and interfering transmissions, the method generates two transmission power control signals: one based on the measured strength of a signal received from the base station and the other based on an accumulated value of power control commands transmitted by the base station. These two signals are accumulated and used to control the preamble signal.

FOR THE PURPOSES OF INFORMATION ONLY

Codes used to identify States party to the PCT on the front pages of pamphlets publishing international applications under the PCT.

AL	Albania	ES	Spain	LS	Lesotho	SI	Slovenia
AM	Armenia	FI	Finland	LT	Lithuania	SK	Slovakia
AT	Austria	FR	France	LU	Luxembourg	SN	Senegal
AU	Australia	GA	Gabon	LV	Latvia	SZ	Swaziland
AZ	Azerbaijan	GB	United Kingdom	MC	Monaco	TD	Chad
BA	Bosnia and Herzegovina	GE	Georgia	MD	Republic of Moldova	TG	Togo
BB	Barbados	GH	Ghana	MG	Madagascar	TJ	Tajikistan
BE	Belgium	GN	Guinea	MK	The former Yugoslav Republic of Macedonia	TM	Turkmenistan
BF	Burkina Faso	GR	Greece	ML	Mali	TR	Turkey
BG	Bulgaria	HU	Hungary	MN	Mongolia	TT	Trinidad and Tobago
BJ	Benin	IE	Ireland	MR	Mauritania	UA	Ukraine
BR	Brazil	IL	Israel	MW	Malawi	UG	Uganda
BY	Belarus	IS	Iceland	MX	Mexico	US	United States of America
CA	Canada	IT	Italy	NE	Niger	UZ	Uzbekistan
CF	Central African Republic	JP	Japan	NL	Netherlands	VN	Viet Nam
CG	Congo	KE	Kenya	NO	Norway	YU	Yugoslavia
CH	Switzerland	KG	Kyrgyzstan	NZ	New Zealand	ZW	Zimbabwe
CI	Côte d'Ivoire	KP	Democratic People's Republic of Korea	PL	Poland		
CM	Cameroon	KR	Republic of Korea	PT	Portugal		
CN	China	KZ	Kazakistan	RO	Romania		
CU	Cuba	LC	Saint Lucia	RU	Russian Federation		
CZ	Czech Republic	LI	Liechtenstein	SD	Sudan		
DE	Germany	LK	Sri Lanka	SE	Sweden		
DK	Denmark	LR	Liberia	SG	Singapore		
EE	Estonia						

**POWER CONTROL DEVICE AND METHOD FOR REVERSE LINK
COMMON CHANNEL IN MOBILE COMMUNICATION SYSTEM**

BACKGROUND OF THE INVENTION

5 **1. Field of the Invention**

The present invention relates generally to a power control device and method for a mobile communication system, and in particular, to a power control device and method for a reverse link common channel.

2. Description of the Related Art

10 In general, an existing code division multiple access (CDMA) mobile communication system is based on the IS-95 standard which mainly supports a voice service. However, in the near future, mobile communication will be performed in accordance with the IMT-2000 standard which supports not only the voice service but also a high-speed data transfer service. For example, the IMT-
15 2000 standard can support a high-quality voice service, a moving picture service, an Internet search service, etc.

In the CDMA mobile communication system, a radio link between a base station and a mobile station is divided into a forward link for transmitting a signal from the base station to the mobile station and a reverse link for transmitting a
20 signal from the mobile station to the base station.

- 2 -

Reverse (link) common channels include a reverse common control channel (R-CCCH) and a reverse access channel (R-ACH). The reverse common control channel and the reverse access channel undergo power adjustment by the exchange of a message and an acknowledge (ACK) between a base station and a mobile station, but do not undergo fast closed-loop power control which will be described below.

A description will be made hereinbelow regarding a conventional power control method for a reverse common control channel and a reverse access channel.

The power control method is divided into an open-loop power control method and a closed-loop power control method. In the open-loop power control method, a mobile station measures the strength of a signal received over the forward link and compares the measured value with a threshold. When the strength of the received signal is smaller than the threshold, the mobile station increases transmission power; otherwise, when the strength of the received signal is greater than the threshold, the mobile station decreases the transmission power.

In the closed-loop power control method, a mobile station transmits a message to a base station over a reverse link and then, determines whether or not an acknowledge (ACK) is received from the base station. Upon failure to receive the acknowledge, the mobile station transmits the message again with transmission power increased by a predetermined level so as to access the base station.

The reverse common control channel and the reverse access channel are contention-based channels. When multiple mobile stations simultaneously attempt to access a base station using through the channels, contention may occur between them. In this case, the respective mobile stations again attempt to access the base station with increased power, causing an increase in interference between the

- 3 -

reverse links of the mobile communication system. This results in performance degradation of other mobile stations channel qualities. This problem will become clearer in the following descriptions.

FIG. 1 illustrates a conventional power control method for the reverse link
5 common channel. Referring to FIG. 1, a mobile station sends a preamble signal to a base station with minimum power in an attempt to access a base station. In FIG. 1, T_1 denotes the time when the first attempt to access the base station is made. When it fails to access the base station because of contention with other mobile stations, the mobile station waits for a predetermined time, and then, at time T_2 ,
10 again attempts to access the base station by increasing the transmission power. When it fails to access the base station again, the mobile station waits for a predetermined time again, and then, at time T_3 , attempts to access the base station with a further increase in transmission power. Here, the predetermined time is the sum of a fixed time and a random time.

15 In this case, contention occurring among multiple mobile stations may cause an increase in interference of the overall system due to the overly increased transmission power. Therefore, when packet data is transmitted over a reverse common control channel, this excessive transmission power problem may occur. Accordingly, there is a need for a fast power control method that suppresses
20 excessive transmission power.

In general, a power control method for the reverse traffic channel aims at maintaining a signal-to-noise ratio (E_b/N_o) for a signal received from a base station. However, in a power control method for the reverse common channel, multiple mobile stations are controlled by one power control command stream, thus reducing
25 the excessive reverse transmission power.

SUMMARY OF THE INVENTION

It is an object of the present invention to provide a power control device and method for reducing the excessive signal power of a reverse common channel in a mobile communication system.

5 It is another object of the present invention to provide a device and method for controlling transmission power of a reverse common channel using both open-loop power control and closed-loop power control in a mobile communication system.

To achieve the above and other objects, there is provided a method for
10 controlling the transmission power of a reverse common channel for a mobile station in a CDMA communication system. In this method, the mobile station transmits a preamble signal at predetermined intervals, increasing the transmission power each time, until receipt of an acknowledge signal from a base station, at which time the mobile station accesses the reverse common channel. The method
15 comprises the following steps: measuring the strength of a received signal to generate a first transmission power control signal for the preamble signal; accumulating power control commands received for a predetermined time over a forward common channel to generate an accumulated value, comparing the accumulated value with a threshold, and generating a second transmission power
20 control signal for decreasing transmission power when it is required to decrease the transmission power, and maintaining a present transmission power when it is required to increase the transmission power ; and accumulating the first and second transmission power control signals and controlling the preamble signal according to the accumulated transmission power control signal.

BRIEF DESCRIPTION OF THE DRAWINGS

The above and other objects, features and advantages of the present invention will become more apparent from the following detailed description when taken in conjunction with the accompanying drawings in which:

5 FIG. 1 is a diagram of a conventional power control method for a reverse common channel in a CDMA mobile communication system;

 FIG. 2 is a block diagram illustrating a channel transmission device for a CDMA mobile communication system;

 FIG. 3 is a flow chart illustrating an open-loop power control method for a
10 reverse common channel in a CDMA mobile communication system;

 FIG. 4 is a flow chart illustrating a power control method for a reverse common channel using both open-loop power control and closed-loop power control in a CDMA mobile communication system according to an embodiment of the present invention; and

15 FIG. 5 is a block diagram illustrating a power control determiner according to an embodiment of the present invention.

DETAILED DESCRIPTION OF THE PREFERRED EMBODIMENT

A preferred embodiment of the present invention will be described hereinbelow with reference to the accompanying drawings.

20 The term "power control bit" (PCB) as used herein refers to a control bit which is transmitted to command the other party to increase or decrease transmission power, in order to control transmission power of the other party.

In an embodiment of the present invention, an open-loop power control

method and a closed-power control method are used together in order to control the power of a reverse link common channel. Preferably, the reverse link common channel is used for the exchange of layer 3 and MAC (Medium Access Control) messages between a base station and a mobile station in a CDMA mobile communication system. When using the open-loop power control method, the power of the reverse link common channel is controlled according to the strength of a received signal. When using the closed-loop power control method, the power of the reverse link common channel is controlled by a power control signal transmitted from the base station. If the power control signal is a power-down command, the transmission power of the common channel is decreased; otherwise, the present transmission power is maintained. In this manner, interference due to excessive signal power of the reverse common channel is reduced.

FIG. 2 illustrates a channel transmission device for a CDMA communication system. For convenient explanation, it is assumed herein that the input data is a 20ms frame of data at full rate.

Referring to FIG. 2, a 172-bit data frame is input to a Cyclic Redundancy Code (CRC) generator 111 which adds a 12-bit CRC. The output of the CRC generator 111 is input to a tail bit generator 112 which generates 8 tail bits to add to the terminating point of the frame data in order that an encoder 113 can initialize data in a frame unit. Therefore, for the 172-bit input data, the tail bit generator 112 outputs 192-bit data. The encoder 113 then encodes frame data output from the tail bit generator 112 into 576 symbols per frame, and an interleaver 114 interleaves the encoded data output from the encoder 113.

A bit selector 117 decimates a long code output from a long code generator 116 to match a length of the long code to the length of the interleaved encoded data.

- 7 -

An exclusive OR (XOR) gate 115 XORs the interleaved encoded data and the decimated long code to scramble the interleaved encoded data. Next, a signal convertor 118 multiplexes the output of the exclusive OR gate 115 to output odd-numbered data to a first channel (i.e., I-channel) and even-numbered data to a second channel (i.e., Q-channel), wherein the output signals are level converted in such a manner that a signal "0" is converted to "+1" and a signal "1" to "-1". The level-converted signals for I and Q channels are gain controlled by channel gain controllers 119 and 121, respectively.

A control bit generator 120 generates a control bit to be inserted in the reverse common channel. A puncturer-inserter 122 and a puncturer-inserter 123 insert the control bit output from the control bit generator 120 in output data of the channel gain controllers 119 and 121 at a location designated by the bit selector 117. A multiplier 124 multiplies an output of the puncturer-inserter 122 by an assigned Walsh code to generate a spread I-channel signal, and a multiplier 125 multiplies an output of the puncturer-inserter 123 by the assigned Walsh code to generate a spread Q-channel signal.

FIG. 5 illustrates a power control determiner for controlling power of a reverse common channel according to an embodiment of the present invention. This power control method for a reverse common channel uses a mix of (1) the power control method of FIG. 1, for increasing transmission power at predetermined time periods until access to a base station is made, (2) an open-loop power control method for measuring strength of a received signal to control transmission power, and (3) a fast closed-loop power control method for controlling transmission power using a power control command. Herein, a detailed description of the power control method of FIG. 1 will be avoided. Instead, the description will be made focusing on the open-loop power control method and the fast closed-loop power control method.

Referring to FIG. 5, a measured power level comparator 411 compares signal strength transmitted from a base station with a threshold and generates a comparison result to determine how to control the transmission power of the reverse common channel. When the strength of the received signal is greater than the threshold, a transmission power decreasing device 413 is enabled; otherwise, when the strength of the received signal is smaller than the threshold, the comparator 411 enables a transmission power increasing device 412. A first transmission power determiner 414 then analyzes the outputs of the transmission power increasing device 412 and the transmission power decreasing device 413, to generate an open-loop power control signal.

The elements 411-414 constitute an open-loop power controller which increases or decreases transmission power of the reverse common channel according to the strength of the received signal.

Next, a PCB accumulation register 421 accumulates PCBs received from the base station. An accumulated PCB value comparator 422 compares the accumulated PCB value output from the PCB accumulation register 421 with an internal maximum value and generates a comparison result. As the result of the comparison, when it is required to decrease transmission power, the comparator 422 enables a transmission power decreasing device 423. However, when it is required to increase the transmission power, the transmission power of the reverse common channel remains unchanged at the present transmission power level. A second transmission power determiner 424 then analyzes outputs of the transmission power decreasing device 423 and the comparator 422, to generate a closed-loop power control signal.

The elements 421-424 constitute a closed-loop power controller, which analyzes an accumulated PCB value to decrease the transmission power of the

reverse common channel only when it is required to decrease the transmission power and to maintain the present transmission power of the reverse common channel when it is required to increase the transmission power. With respect to the closed-loop power control, the maximum value compared with the accumulated
5 PCB value is a system parameter which can be determined through experiments, and is the maximum value permitted when transmission power is increased by the fast close-loop power control. Further, for the fast closed-loop power control, a base station may send a power control command on the basis of a mobile station with the highest transmission power out of multiple mobile stations which attempt to access
10 the base station. Therefore, when the transmission power of the mobile station which attempts to access the base station with the highest transmission power is reduced in a large amount, the mobile stations which attempt to access the base station with lower transmission power may fail to access the base station.

A transmission power accumulator 415 accumulates the open-loop power
15 control signal and the closed-loop power control signal output from the transmission power determiners 414 and 424, to output a transmission power control signal. The transmission power control signal output from the transmission power accumulator 415 depends on both the strength of the received signal and the analyzed result of the PCBs transmitted from the base station. This transmission power control signal
20 is accumulated again with a power control signal generated in the power control method of FIG. 1, and then used as a transmission power control signal for a preamble signal.

That is, as illustrated in FIG. 1, a preamble transmitter (not shown) sends a preamble signal at predetermined intervals which consist of a fixed time period
25 added to a random time period, and increases the transmission power at each interval. Then, a first transmission power controller (i.e., the open-loop power

- 10 -

controller) measures the strength of the signal received from the base station to generate the first transmission power control signal for controlling transmission power of the preamble signal. Further, a second transmission power controller (i.e., the closed-loop power controller) accumulates PCBs received over the forward
5 common channel for a predetermined time to generate an accumulated PCB value and compares the accumulated PCB value with a threshold. As the result of comparison, when it is required to decrease the transmission power, the second transmission power controller generates a second transmission power control signal for decreasing the transmission power by a predetermined value. Otherwise, the
10 second transmission power controller generates a second transmission power control signal for maintaining the present transmission power. The transmission power accumulator 415 accumulates the first transmission power control signal and the second transmission power control signal, and applies the accumulated signal to the preamble transmitter to control transmission power of the preamble signal.

15 As described above, the threshold used when the closed-loop power controller determines the second transmission power control signal is the maximum value permitted when the transmission power is increased in response to the power control command. The base station generates a power control command to decrease the transmission power of the preamble signal on the basis of the mobile station
20 with the highest transmission power. Upon receipt of the power control command, all of the other mobile stations, but not the mobile station which attempted to access the base station with the highest transmission power, decrease the transmission power to the lowest extent. Therefore, it is possible to reduce interference due to excessive transmission power of the mobile stations which cannot access the base
25 station.

FIG. 3 illustrates an open-loop power control method performed in the open

loop power control (411 - 414) of FIG. 5.

Referring to FIG. 3, the open loop power control determiner measures strength, RSSI, of a signal received from a base station in step 212. Since a method for measuring the received signal strength is well known in the art, a detailed description will be avoided herein. After measuring the signal strength, the power control determiner compares the measured signal strength with a threshold in step 213. As the result of the comparison, when the received signal strength is lower than the threshold, transmission power of the mobile station is increased by a predetermined value (x dB) in step 215; otherwise, when the received signal strength is higher than the threshold, the transmission power of the mobile station is decreased by a predetermined value (x dB) in step 214.

After controlling the transmission power in steps 214 or 215, the power control determiner transmits a preamble signal to the base station in step 216, and determines in step 217 whether an acknowledge signal is received from the base station. Upon receipt of the acknowledge signal, the power control determiner communicate through the common channel and ends the procedure. However, upon failure to receive the acknowledge, the power control determiner passes a predetermined time T_w in step 218 and then returns to step 212.

FIG. 4 illustrates a power control method for a reverse common channel using both open-loop power control and closed-loop power control, performed in the power control determiner of FIG. 5.

Referring to FIG. 4, the power control determiner initializes a PCB accumulation register value PWR_ACC_REG to "0". Here, the open-loop power control procedure (211 - 214/5) of FIG. 3 is performed in step 330. That is, in step

- 12 -

330, the mobile station measures strength of a signal transmitted from a base station and compares the measured signal strength with a threshold. When the measured signal strength value is lower than the threshold, transmission power of a preamble signal is increased by a predetermined value (x dB); when the measured signal strength value is higher than the threshold, the transmission power of the preamble signal is decreased by a predetermined value (x dB).

With respect to a closed-loop power control procedure, the power control determiner receives a power control command (PCB) transmitted from the base station and determines whether it is a power-up command or a power-down command, in step 313. For example, the power control command value can be +1 for the power-up command, and -1 for the power-down command. Then the power control determiner accumulates the power control command values in step 314. The accumulated power control command value is compared with a maximum value in step 315. Here, the maximum value can be 0 or can be given as a system parameter. When the accumulated power control command value is greater than the maximum value, i.e., when it is required to increase transmission power of a preamble signal, the power control determiner maintains the present transmission power by jumping to step 317. However, when the accumulated power control command value is smaller than the maximum value, i.e., when it is required to decrease the transmission power of the preamble signal, the power control determiner decreases the transmission power of the preamble signal by a predetermined value (y dB) in step 316. After steps 315 and 316, the power control determiner initializes the PCB accumulation register value PWR_ACC_REG in step 317 and increases a variable n by "1" in step 318.

The power control determiner increases or decreases the transmission power of the preamble signal according to the open-loop and closed-loop power control

results, in step 319. That is, the power control determiner combines the signal determined by the open-loop power control procedure and the signal determined by the closed-loop power control procedure, to determine the transmission power of the reverse common channel.

5 In step 320, it is determined whether an acknowledge signal is received from the base station. Upon receipt of the acknowledge signal, the procedure goes to step 321 where communication is made through the common channel. However, upon failure to receive the acknowledge signal, the procedure returns to step 313. In this manner, when contention occurs among multiple mobile stations, it is possible to
10 reduce rather than increase the interference which may occur during the closed-loop power control method.

 In the meantime, for the method of transmitting a power control command from a base station to a mobile station, it is possible to use a forward link common sub-control channel in addition to the forward link common control channel. That
15 is, the base station transmits a power control command using the separate sub-control channel to the mobile station. As another method for transmitting a power control command to the mobile station, the base station can puncture a paging channel or a forward common control channel in order to transmit the power control bit by inserting it in the punctured location. As further another method for
20 transmitting a power control command to the mobile station, the base station can transmit the power control command as a separate message using the paging channel or the forward common control channel.

 As described above, the power control method reduces the interference due to the excessive signal power on the reverse common channel which occurs when
25 multiple mobile stations simultaneously attempt to access a base station on a

contention basis, in a mobile communication system.

While the invention has been shown and described with reference to a certain preferred embodiment thereof, it will be understood by those skilled in the art that various changes in form and details may be made therein without departing from
5 the spirit and scope of the invention as defined by the appended claims.

WHAT IS CLAIMED IS:

1. A method for controlling transmission power of a reverse common channel for a mobile station in a code division multiple access (CDMA) communication system, comprising the steps of:
 - 5 accumulating power control signals received for a predetermined time over a forward common channel to generate an accumulated value;
 - comparing the accumulated value with a threshold;
 - if the accumulated value is less than the threshold, generating a command to decrease the transmission power;
 - 10 if the accumulated value is greater than the threshold, maintaining the present transmission power.
2. The method as claimed in claim 1, said mobile station having a preamble signal which is transmitted over the reverse common channel, wherein said method further comprises the steps of discontinuing transmission of the
15 preamble signal and accessing the reverse common channel, upon receipt of an acknowledge signal from the base station.
3. The method as claimed in claim 2, wherein the forward common channel is a forward common sub-control channel for transmitting a power control command exclusively.
- 20 4. The method as claimed in claim 2, wherein a base station measures the received power of the reverse link, generates a corresponding power control bit, inserts the power control bit in the forward common control channel at a predetermined location, and transmits the forward common control channel.

5. The method as claimed in claim 2, wherein the forward common channel is a forward common control channel for transmitting a power control command message generated by a base station for the reverse link common channel.

6. A method for controlling transmission power of a reverse common channel for a mobile station in a CDMA communication system in which the mobile station transmits a preamble signal at predetermined intervals with increasing transmission power and accesses a reverse common channel upon receipt of an acknowledge signal from a base station, the method comprising the steps of:

measuring the strength of a received signal to generate a first transmission power control signal for the preamble signal;

accumulating power control commands received for a predetermined time over a forward common channel to generate an accumulated value, comparing the accumulated value with a threshold, generating a second transmission power control signal for decreasing the transmission power when it is required to decrease the transmission power, and maintaining the present transmission power when it is required to increase the transmission power; and

accumulating the first and second transmission power control signals and controlling the preamble signal according to the accumulated transmission power control signal.

7. The method as claimed in claim 6, wherein a threshold for determining the second transmission power control signal is a maximum value permitted when the transmission power is increased according to a power control command generated by the base station on the basis of the transmission power of a mobile station which attempts to access the base station with the highest transmission power.

- 17 -

8. The method as claimed in claim 7, further comprising the step of discontinuing transmission of the preamble signal and accessing the reverse common channel, upon receipt of an acknowledge signal from the base station.

9. A device for controlling transmission power of a reverse common
5 channel for a mobile station in a CDMA communication system, the device comprising:

an accumulator for accumulating power control signals received for a predetermined time over a forward common channel, said accumulator generating an accumulated value in order to control the transmission power of the reverse common
10 channel; and

a power controller for comparing the accumulated value with a threshold, generating a power-down command when it is required to decrease the transmission power, and maintaining a present transmission power when it is required to increase the transmission power.

15 10. The device as claimed in claim 9, wherein a signal transmitted over the reverse common channel is a preamble signal.

11. The device as claimed in claim 9, wherein the forward common channel is a forward common sub-control channel for transmitting a power control command exclusively.

20 12. A device for controlling transmission power of a reverse common channel for a mobile station in a CDMA communication system, the device

comprising:

a preamble signal transmitter for transmitting a preamble signal at predetermined intervals by increasing transmission power;

an open-loop power controller for measuring the strength of a received signal
5 to generate a first transmission power control signal for the preamble signal;

a power controller for accumulating the power control commands received for a predetermined time over a forward common channel to generate an accumulated value, comparing the accumulated value with a threshold, and generating a second transmission power control signal for either decreasing the transmission power when
10 it is required to decrease the transmission power, or maintaining the present transmission power when it is required to increase the transmission power; and

an accumulator for accumulating the first and second transmission power control signals and applying the accumulated transmission power control signal to the preamble transmitter.

15 13. The device as claimed in claim 12, wherein a threshold for determining the second transmission power control signal is a maximum value permitted when the transmission power is increased according to a power control command generated by the base station on a basis of the transmission power of a mobile station which attempts to access the base station with the highest transmission power.

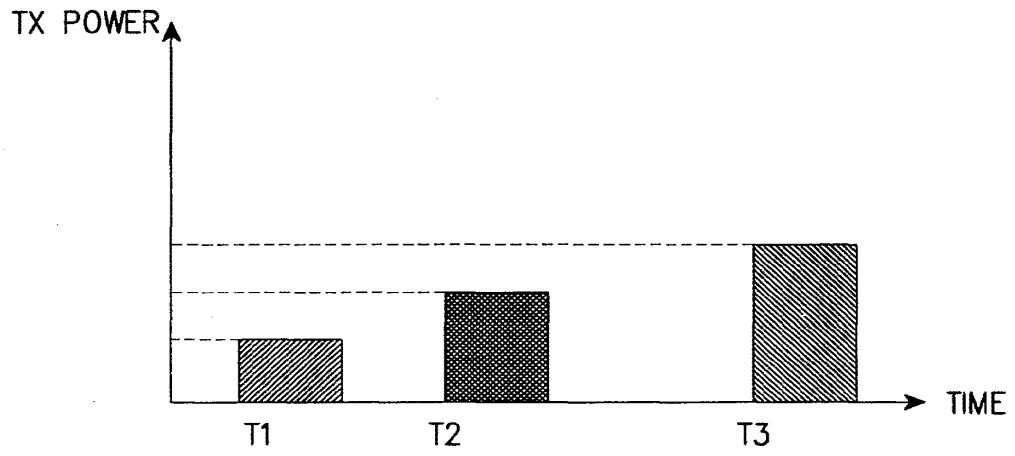

FIG. 1

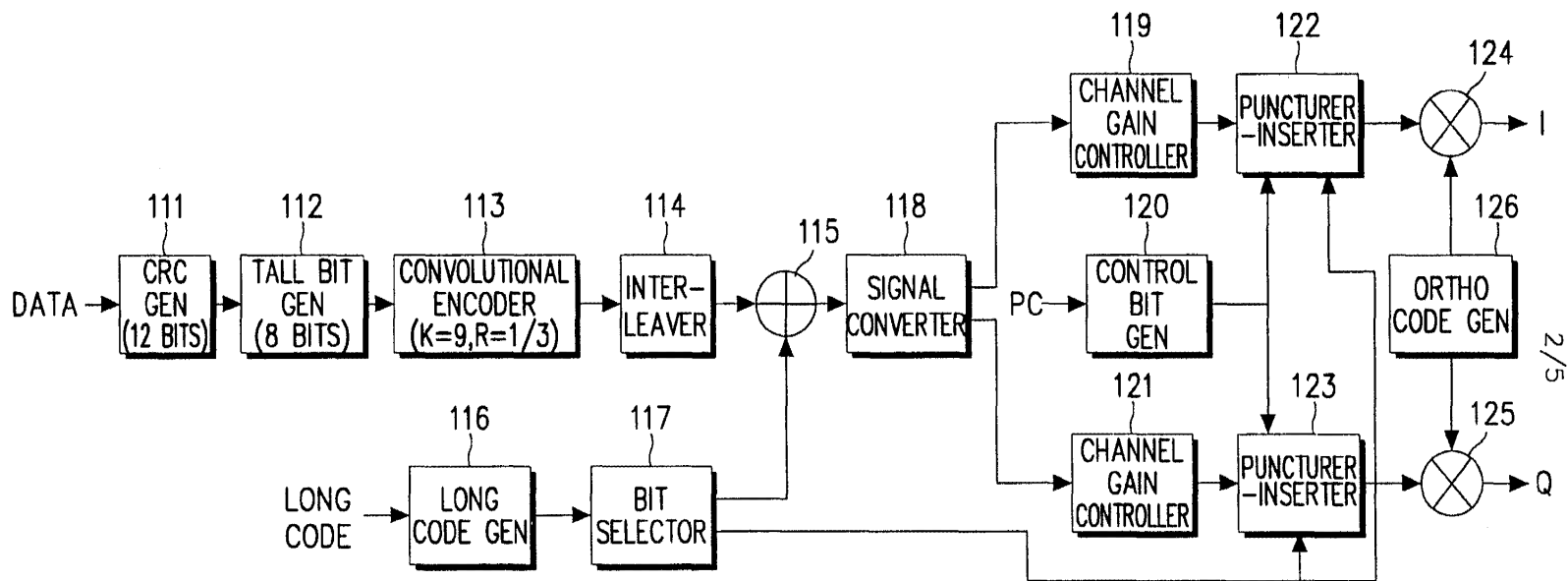

FIG. 2

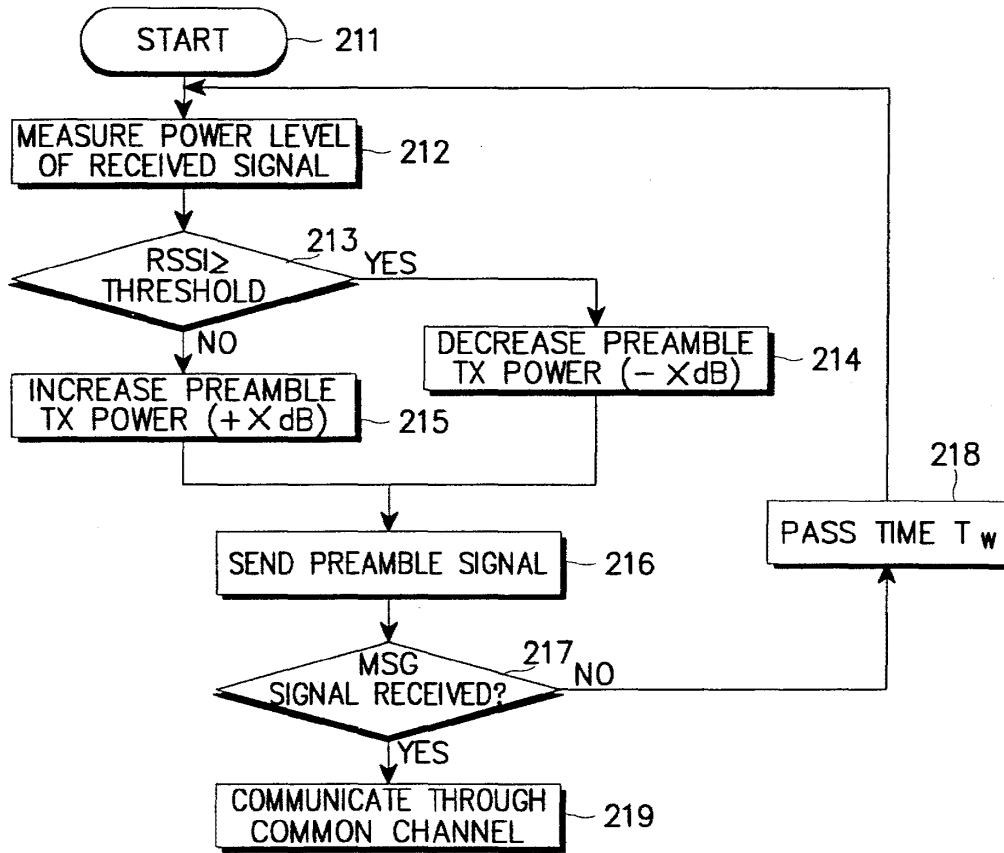

FIG. 3

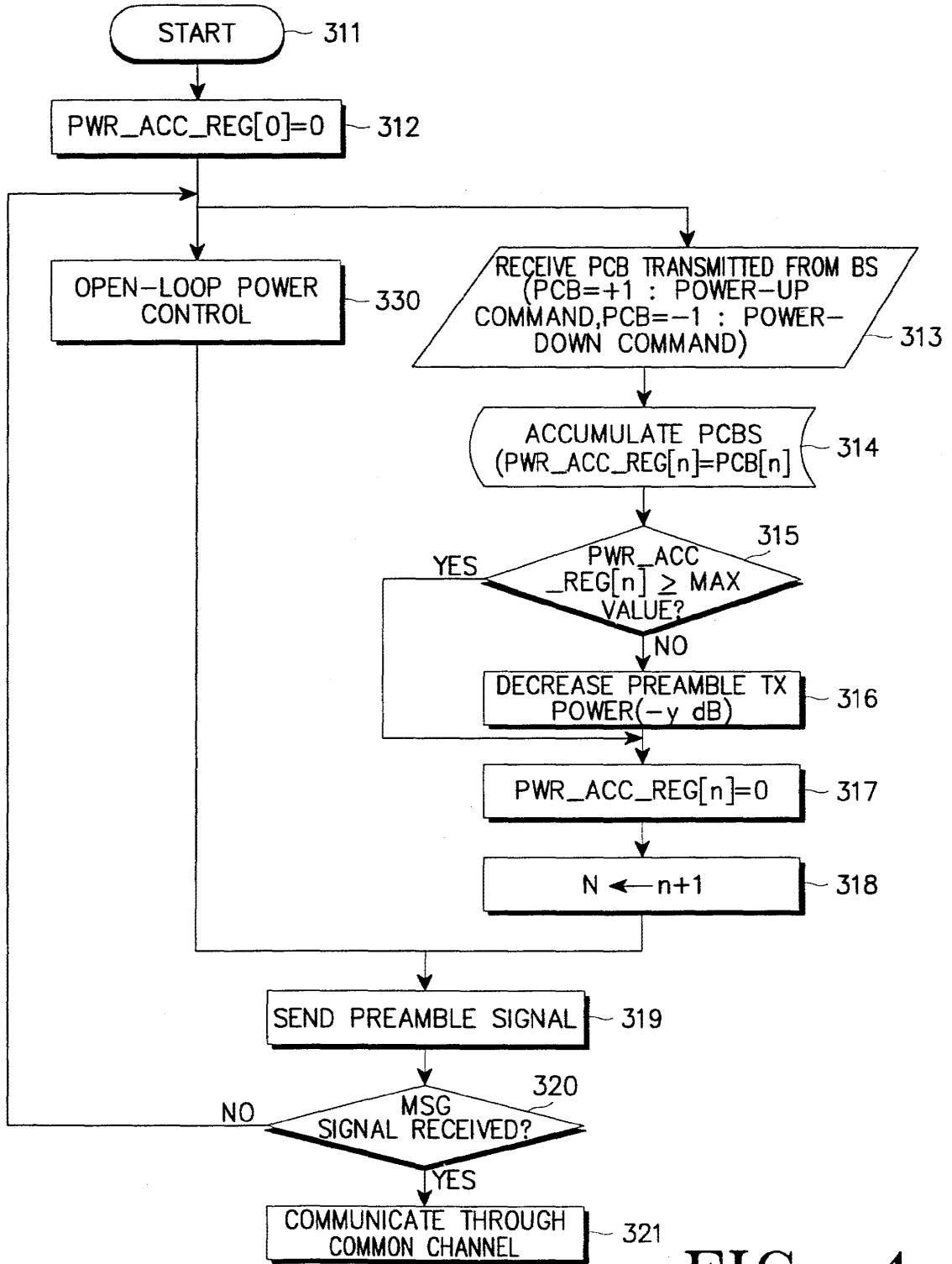

FIG. 4

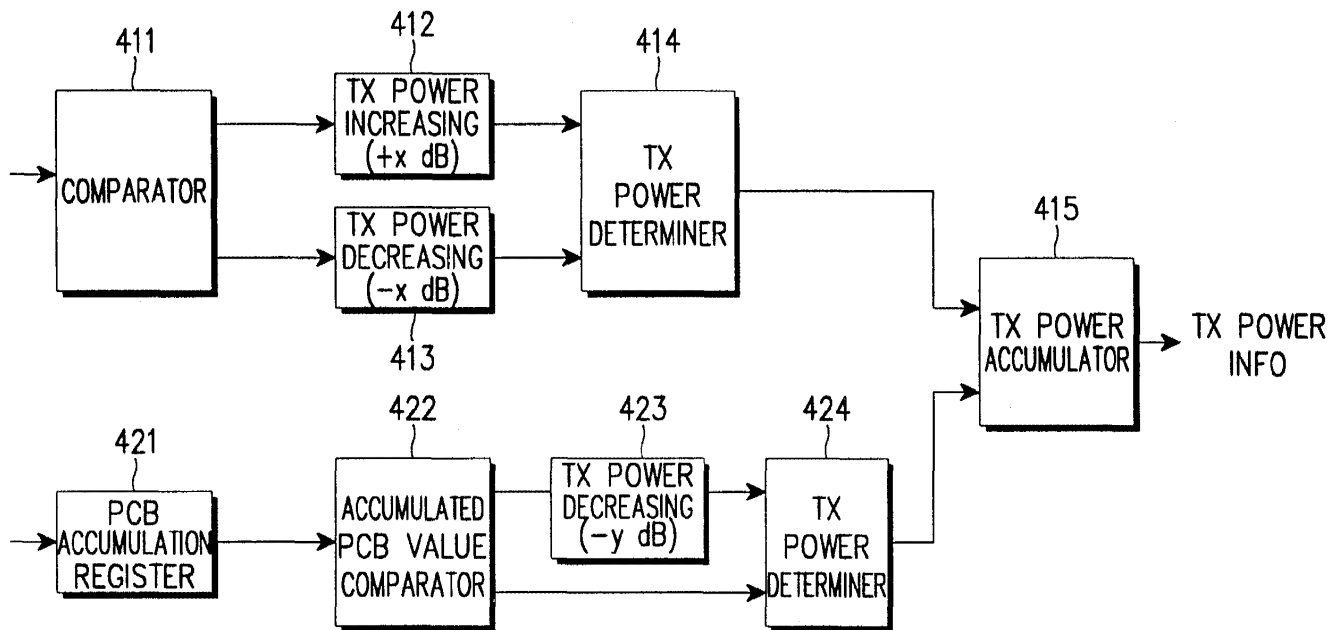

FIG. 5

INTERNATIONAL SEARCH REPORT

International application No.
PCT/KR 99/372

A. CLASSIFICATION OF SUBJECT MATTER IPC ⁷ : H 04 B 7/216 According to International Patent Classification (IPC) or to both national classification and IPC		
B. FIELDS SEARCHED Minimum documentation searched (classification system followed by classification symbols) IPC ⁷ : H 04 B 7/00, 7/204, 7/216 Documentation searched other than minimum documentation to the extent that such documents are included in the fields searched Electronic data base consulted during the international search (name of data base and, where practicable, search terms used) WPIL		
C. DOCUMENTS CONSIDERED TO BE RELEVANT		
Category*	Citation of document, with indication, where appropriate, of the relevant passages	Relevant to claim No.
A	US 5265119 A (K. S. GILHOUSEN et al.) 23 November 1993 (23.11.93) totality. -----	1-13
<input type="checkbox"/> Further documents are listed in the continuation of Box C. <input checked="" type="checkbox"/> See patent family annex.		
* Special categories of cited documents: „A“ document defining the general state of the art which is not considered to be of particular relevance „E“ earlier application or patent but published on or after the international filing date „L“ document which may throw doubts on priority claim(s) or which is cited to establish the publication date of another citation or other special reason (as specified) „O“ document referring to an oral disclosure, use, exhibition or other means „P“ document published prior to the international filing date but later than the priority date claimed „T“ later document published after the international filing date or priority date and not in conflict with the application but cited to understand the principle or theory underlying the invention „X“ document of particular relevance; the claimed invention cannot be considered novel or cannot be considered to involve an inventive step when the document is taken alone „Y“ document of particular relevance; the claimed invention cannot be considered to involve an inventive step when the document is combined with one or more other such documents, such combination being obvious to a person skilled in the art „&“ document member of the same patent family		
Date of the actual completion of the international search	26 September 1999 (26.09.99)	Date of mailing of the international search report
		03 December 1999 (03.12.99)
Name and mailing address of the ISA/AT Austrian Patent Office Kohlmarkt 8-10; A-1014 Vienna Facsimile No. 1/53424/200	Authorized officer Zugarek Telephone No. 1/53424/451	

Form PCT/ISA/210 (second sheet) (July 1998)

INTERNATIONAL SEARCH REPORT

Information on patent family members

International application No.

PCT/KR 99/00372

In Recherchenbericht angeführtes Patentedokument Patent document cited in search report Document de brevet cité dans le rapport de recherche	Datum der Veröffentlichung Publication date Date de publication	Mitglied(er) der Patentfamilie Patent family member(s) Membre(s) de la famille de brevets	Datum der Veröffentlichung Publication date Date de publication
US A	5265119	23-11-1993	
		AT E	163822
		AU A1	67283790
		AU B2	646001
		BR A	9007826
		CA AA	2072989
		CN A	1053870
		CN E	1025402
		CN A	1090107
		CN B	1035597
		CN A	1159720
		DE C	69032105
		DE T2	69032105
		DE A1	500689
		DE A4	500689
		DE B1	500689
		FI A	2113862
		FI A	922083
		FI A0	922083
		GR T3	3026454
		HK A1	1010077
		IL A	46218
		JP T2	4502841
		JP B2	2776532
		MX B	172367
		NO A0	921792
		NO A	921792
		NO B1	304206
		SE A1	48360
		US A	5056109
		WD A1	9107037
		ZA A	9008859
		US A	5257283
		US A	5267262
		US A	5485484
		AU A1	20091/92
		AU B2	653039
		EP A1	584241
		EP A4	584241
		FI A	925105
		FI A0	925105
		HU A2	66044
		HU E	215857
		JP T2	7500480
		NO A	934005
		NO A0	934005
		SE A1	48018
		WD A1	9221196
			15-03-1998
			31-05-1991
			03-02-1994
			25-08-1992
			08-05-1991
			14-08-1991
			06-07-1994
			27-07-1994
			06-08-1997
			17-09-1997
			09-04-1999
			08-10-1999
			02-09-1999
			24-03-1999
			04-04-1999
			16-05-1999
			07-05-1999
			07-05-1999
			30-06-1999
			11-06-1999
			16-08-1999
			21-09-1999
			16-07-1999
			14-12-1999
			06-05-1999
			06-07-1999
			09-11-1999
			17-04-1999
			08-10-1999
			16-05-1999
			23-09-1999
			26-10-1999
			30-11-1999
			16-01-1999
			30-12-1999
			15-09-1994
			02-03-1994
			31-07-1994
			17-11-1994
			17-11-1994
			28-09-1994
			09-03-1999
			12-01-1999
			05-11-1999
			05-11-1999
			17-04-1999
			26-11-1992



INTERNATIONAL APPLICATION PUBLISHED UNDER THE PATENT COOPERATION TREATY (PCT)

<p>(51) International Patent Classification ⁷ : H04B 7/005</p>	<p>A1</p>	<p>(11) International Publication Number: WO 00/62441 (43) International Publication Date: 19 October 2000 (19.10.00)</p>
<p>(21) International Application Number: PCT/SE00/00645 (22) International Filing Date: 4 April 2000 (04.04.00) (30) Priority Data: 09/288,860 9 April 1999 (09.04.99) US (71) Applicant: TELEFONAKTIEBOLAGET LM ERICSSON (PUBL) [SE/SE]; S-126 25 Stockholm (SE). (72) Inventors: ANDERSSON, Christoffer; Kårhusvägen 2:155, S-977 54 Luleå (SE). ERICSON, Märten; Höstvägen 50, S-976 33 Luleå (SE). (74) Agent: KLAS, Norin; Ericsson Radio Systems AB, Common Patent Dept., S-164 80 Stockholm (SE).</p>	<p>(81) Designated States: AE, AG, AL, AM, AT, AU, AZ, BA, BB, BG, BR, BY, CA, CH, CN, CR, CU, CZ, DE, DK, DM, DZ, EE, ES, FI, GB, GD, GE, GH, GM, HR, HU, ID, IL, IN, IS, JP, KE, KG, KP, KR, KZ, LC, LK, LR, LS, LT, LU, LV, MA, MD, MG, MK, MN, MW, MX, NO, NZ, PL, PT, RO, RU, SD, SE, SG, SI, SK, SL, TJ, TM, TR, TT, TZ, UA, UG, UZ, VN, YU, ZA, ZW, ARIPO patent (GH, GM, KE, LS, MW, SD, SL, SZ, TZ, UG, ZW), Eurasian patent (AM, AZ, BY, KG, KZ, MD, RU, TJ, TM), European patent (AT, BE, CH, CY, DE, DK, ES, FI, FR, GB, GR, IE, IT, LU, MC, NL, PT, SE), OAPI patent (BF, BJ, CF, CG, CI, CM, GA, GN, GW, ML, MR, NE, SN, TD, TG).</p> <p>Published <i>With international search report. Before the expiration of the time limit for amending the claims and to be republished in the event of the receipt of amendments.</i></p>	

(54) Title: ADAPTIVE POWER CONTROL IN A MOBILE RADIO COMMUNICATIONS SYSTEM

(57) Abstract

An efficient and effective power control in a mobile communications system is provided that adapts to rapidly changing radio transmission conditions in varying and often unpredictable situations. The value of a signal parameter detected from a signal received by a radio transceiver is compared with a desired signal parameter value, and a difference is determined. A transmit power control command is sent to the radio transceiver and may instruct, for example, an increase or decrease in the level of radio transmit power. Included with the transmit power control command is a power control indicator indicating whether a first or a second type of power control adjustment should be used by the radio transceiver depending upon the determined difference. In one example embodiment, the power control indicator is a single flag bit. A first value indicates that the first type of power control adjustment should be used; the second value indicates that the second type of power control adjustment should be used. In any event, the power control indicator itself does not include specific details of the first or second type of power control adjustment. Because only the indicator is sent (and not the details), signaling overhead and bandwidth consumption related to frequently sent power control commands are kept to a minimum. The specific details of the first and second power control adjustments are initially stored in to the radio transceiver. Such details may be updated when desirable, but the frequency of such updating is likely to be infrequent. Alternatively, a power control indicator may be communicated using techniques other than adding one or more flag bits to a fast transmit power control message to effect a change in power control type as long as signaling overhead is not significantly increased.

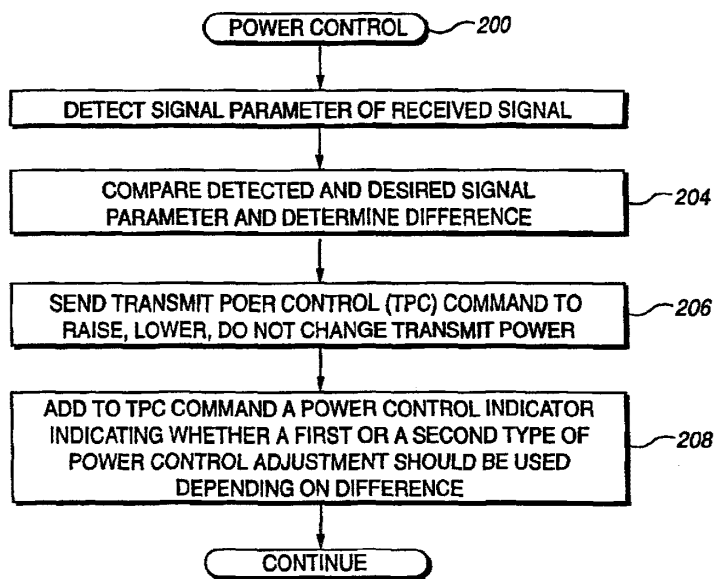

FOR THE PURPOSES OF INFORMATION ONLY

Codes used to identify States party to the PCT on the front pages of pamphlets publishing international applications under the PCT.

AL	Albania	ES	Spain	LS	Lesotho	SI	Slovenia
AM	Armenia	FI	Finland	LT	Lithuania	SK	Slovakia
AT	Austria	FR	France	LU	Luxembourg	SN	Senegal
AU	Australia	GA	Gabon	LV	Latvia	SZ	Swaziland
AZ	Azerbaijan	GB	United Kingdom	MC	Monaco	TD	Chad
BA	Bosnia and Herzegovina	GE	Georgia	MD	Republic of Moldova	TG	Togo
BB	Barbados	GH	Ghana	MG	Madagascar	TJ	Tajikistan
BE	Belgium	GN	Guinea	MK	The former Yugoslav Republic of Macedonia	TM	Turkmenistan
BF	Burkina Faso	GR	Greece	ML	Mali	TR	Turkey
BG	Bulgaria	HU	Hungary	MN	Mongolia	TT	Trinidad and Tobago
BJ	Benin	IE	Ireland	MR	Mauritania	UA	Ukraine
BR	Brazil	IL	Israel	MW	Malawi	UG	Uganda
BY	Belarus	IS	Iceland	MX	Mexico	US	United States of America
CA	Canada	IT	Italy	NE	Niger	UZ	Uzbekistan
CF	Central African Republic	JP	Japan	NL	Netherlands	VN	Viet Nam
CG	Congo	KE	Kenya	NO	Norway	YU	Yugoslavia
CH	Switzerland	KG	Kyrgyzstan	NZ	New Zealand	ZW	Zimbabwe
CI	Côte d'Ivoire	KP	Democratic People's Republic of Korea	PL	Poland		
CM	Cameroon	KR	Republic of Korea	PT	Portugal		
CN	China	KZ	Kazakstan	RO	Romania		
CU	Cuba	LC	Saint Lucia	RU	Russian Federation		
CZ	Czech Republic	LI	Liechtenstein	SD	Sudan		
DE	Germany	LK	Sri Lanka	SE	Sweden		
DK	Denmark	LR	Liberia	SG	Singapore		
EE	Estonia						

ADAPTIVE POWER CONTROL IN A MOBILE RADIO COMMUNICATIONS SYSTEM

FIELD OF THE INVENTION

The present invention relates radio transmission power control in a code
5 division multiple access cellular radio communications system.

BACKGROUND AND SUMMARY OF THE INVENTION

In a cellular communications system, a mobile radio station communicates
over an assigned radio channel with a radio base station. Several base stations are
connected to a switching node which is typically connected to a gateway that interfaces the
10 cellular communications system with other communication systems. A call placed from an
external network to a mobile station is directed to the gateway, and from the gateway
through one or more switching nodes to a base station which serves the called mobile
station. The base station pages the called mobile station and established a radio
communications channel. A call originated by the mobile station follows a similar path in
15 the opposite direction.

In a Code Division Multiple Access (CDMA) mobile communication system,
, spreading codes are used to distinguish information associated with different mobile
stations or base stations transmitting over the same radio frequency band. In other words,
individual radio "channels" correspond to and are discriminated on the basis of these
20 codes. Various aspects of CDMA are set forth in one or more textbooks such as
Applications of CDMA and Wireless/Personal Communications, Garg, Vijay K. et al., Prentice-
Hall 1997.

Spread spectrum communications permit mobile transmissions to be
received at two or more ("diverse") base stations and processed simultaneously to generate
25 one received signal. With these combined signal processing capabilities, it is possible to

perform a handover from one base station to another, (or from one antenna sector to another antenna sector connected to the same base station), without any perceptible disturbance in the voice or data communications. This kind of handover is typically called diversity handover.

5 During diversity handover, the signaling and voice information from plural sources is combined in a common point with decisions made on the “quality” of the received data. In soft handover, as a mobile station involved in a call moves to the edge of a base station’s cell, the adjacent cell’s base station assigns a transceiver to the same call while a transceiver in the current base station continues to handle that call as well. As a
10 result, the call is handed over on a make-before-break basis. Soft diversity handover is therefore a process where two or more base stations handle the call simultaneously until the mobile station moves sufficiently close to one of the base stations which then exclusively handles the call. “Softer” diversity handover occurs when the mobile station is in handover between two different antenna sectors connected to the same, multi-sectored
15 base station using a similar make-before-break methodology.

 Because all users of a CDMA communications system transmit information using the same frequency band at the same time, each user’s communication interferes with the communications of the other users. In addition, signals received by a base station from a mobile station close to the base station are much stronger than signals received from
20 other mobile stations located at the base station’s cell boundary. As a result, distant mobile communications are overshadowed and dominated by close-in mobile stations which is why this condition is sometimes referred as the “near-far effect.”

 The physical characteristics of a radio channel vary significantly for a number of reasons. For example, the signal propagation loss between a radio transmitter and receiver varies as a function of their respective locations, obstacles, weather, etc. As a
25 result, large differences may arise in the strength of signals received at the base station from different mobiles. If the transmission power of a mobile station signal is too low, the receiving base station may not correctly decode a weak signal, and the signal will have to be corrected (if possible) or retransmitted. Accordingly, erroneous receipt of the signals adds

to the delay associated with radio access procedures, increases data processing overhead, and reduces the available radio bandwidth because erroneously received signals must be retransmitted. On the other hand, if the mobile transmission power is too high, the signals transmitted by the mobile station create interference for the other mobile and base stations
5 in the system. Ideally, all mobile-transmitted signals should arrive at the base station with about the same average power irrespective of their distance from the base station.

Interference is a particularly severe problem in CDMA systems because large numbers of radios transmit on the same frequency. If one mobile station transmits at a power output that is too large, the interference it creates degrades the signal-to-interference
10 ratio (SIR) of signals received from other mobile radios to the point that a receiving base station cannot correctly demodulate transmissions from the other mobile radios. In fact, if a mobile station transmits a signal at twice the power level needed for the signal to be accurately received at the base station receiver, that mobile signal occupies roughly twice the system capacity as it would if the signal were transmit at the optimum power level.
15 Unregulated, it is not uncommon for a strong mobile station to transmit signals that are received at the base station at many, many times the strength of other mobile transmissions. The loss of system capacity to such excessively “strong” mobile stations is unacceptable.

Additional problems are associated with transmitting with too much power.
20 One is the so-called “party effect.” If a mobile transmits at too high of a power level, the other mobiles may increase their respective power levels so that they can “be heard” compounding the already serious interference problem.

Another problem is wasted battery power. It is very important to conserve the limited battery life in mobile radios. By far, the largest drain on a mobile’s battery
25 occurs during transmission. A significant objective for any power control approach, therefore, is to reduce transmit power where possible without increasing the number of retransmissions to an unacceptably high level as a consequence of that power reduction. Except for battery consumption, the above-described problems with setting transmission power also apply to downlink radio transmissions from base stations.

Transmit power control (TPC) is therefore important in any mobile radio communications system, and is a particularly significant factor in improving the performance and capacity of a CDMA system. In uplink TPC, the mobile station attempts to control its transmit power based on the power control messages sent to the mobile station from the base station with the goal of controlling the power level of signals received at the base station within a relatively small tolerance, e.g., 1 dB for all mobile station transmissions received at that base station.

More specifically, transmit power control strives to keep the received carrier-to-interference ratio (CIR) close to a target CIR. Alternate measures of signal quality may also be used such as received signal-to-interference ratio (SIR), received signal strength (RSSI), etc. The carrier-to-interference ratio actually received at a base station or mobile station depends on the received carrier power and the current interference level. Received carrier power corresponds to the transmit power level P_{tx} minus the path loss L . The path loss L may also be represented as a negative gain. Such a gain factor includes two components for a radio channel: a slow fading gain G_s and a fast fading gain G_f . The interference from other users in the CDMA system also depends on the spreading factor employed by other transmitters. Accordingly, the carrier-to-interference ratio may be roughly determined in accordance with the following:

$$CIR = \frac{P_i G_i}{\sum_{k=\text{other users}} \frac{P_k G_k}{SF_k} + N} \quad (1)$$

where P corresponds to the transmit power level, G corresponds to the path gain (including both fast and slow fading components), SF is the spreading factor which is equal to the number of "chips" used to spread a data symbol, and N is the background noise.

The power related issues described above for uplink (or reverse) power control for transmissions from the mobile station to the base station also apply in the downlink (or forward) transmit direction from a transceiver in the base station to the mobile station. In downlink power control, the base station varies the power of the

transceiver transmitting to the mobile station depending on downlink transmit power control messages or commands sent by the mobile station.

Because power control in CDMA systems is very important, transmit power control adjustments often occur very frequently, e.g., every 0.625 milliseconds. During transmit power regulation, each station (mobile and base) continually measures the transmit power level received from the other station and determines whether the measured value is greater than a reference value. If so, a transmit power control bit having one value is sent from one station instructing the other station to decrease its transmit power by a predetermined increment, e.g., 1 dB, down to a minimum transmit power value. On the other hand, when the measured value is less than the reference value, the transmit power control bit(s) with the opposite value(s) is (are) transmit to increase transmit power by a predetermined increment, e.g., 1 dB, up to a maximum value. Because power control commands occur very frequently, it is desirable to avoid using large numbers of bits to avoid increasing the signaling “overhead.”

Various factors may cause the received carrier-to-interference ratio to differ from a target carrier-to-interference ratio by as much as 10 dB or more. These factors include environmental conditions such as a rapidly varying radio channel, changing temperatures which affect the performance of radio equipment, practical implementation limitations (e.g., non-linear components used to construct base and mobile stations), and delays in power control commands to name a few. One way to approach power control in view of such problems is to employ an open loop power control in combination with a closed loop power control. In open loop power control, the transmit power is calculated at the transmitter based on one or more parameters, and the calculated value is used to set the transmit power level. The transmit power may be adjusted in order to match an estimated path loss so that the signal is received at the base station at a predetermined power level. Closed loop power control relies on feedback from the receiver so that the transmitter knows, for example, at what CIR level the transmitted signal was received. Using this feedback, the transmitter then appropriately adjusts its transmit power level. A drawback with this approach is its complexity in that two types of power control must be

implemented and coordinated. It is often difficult to guarantee that the two power control schemes work together harmoniously and special hardware may be needed to “mix” these two types of power control. Another drawback is that since this approach responds to path loss changes, it does not compensate for changes in interference.

5 Another less complex approach is a power “ramping” power control technique such as described in Ericsson’s U.S. Patent No. 5,430,760 to Dent. The mobile station initiates a random access at a low initial transmit power level and gradually (e.g., incrementally) increases the transmission power level until the base station detects and acknowledges the access signal. Once detected, the power level of the message is
10 maintained at the detected level.

 While both of these approaches are useful, neither is optimum in all situations and in all respects. As can be seen from equation (1), the interference from other users depends to a significant extent on the spreading factor employed by that user. A low spreading factor corresponding to a smaller number of chips per symbol increases the
15 interference generated by user i considerably. Consider the following scenario. A mobile user having a low spreading factor or otherwise transmitting at a high power, is traveling through a city with a number of buildings and other obstacles. The serving base station is relatively far away. However, as the mobile user rounds a street corner, the user is suddenly very close to another base station previously shadowed or blocked by that building. One
20 practical effect is that when this mobile transmitting at high power rounds the corner, it “blasts” the new, closer base station and nearby users currently being served by that base station. The net result is a large, unnecessary increase in interference in the new base station’s cell(s) which lowers the carrier-to-interference ratio for the other mobile users in the cell(s). As a result, those other mobile users will increase their transmit power levels in
25 order to maintain a reasonable carrier-to-interference ratio, i.e., the party effect referred to above.

 Another example concerns mobile data users that employ low spreading factors. Such users typically do not significantly increase the interference level as long as their data sending/receiving activities are low. However, should such low spreading factor

data users start transmitting at a high data rate, that transmission will be at a much larger transmit power suddenly increasing the interference level. If a 1dB stepsize is employed to decrease that user's transmit power, other users in that cell will not be able to raise their output power fast enough to compensate for this new situation.

5 What is needed, therefore, is an effective power control mechanism that quickly decreases the power of such a mobile user. Such a power control mechanism should also preferably raise power quickly as well but more restrictively than when decreasing power. One approach is to vary the step size in the incremental power control approach mentioned above to accommodate both large and small step sizes. Normally, a
10 relatively small step size is employed. But in situations like that just described where a high power transmission mobile rounds a corner, a large power decrease step is necessary to reduce that mobile's power quickly and by a significant amount. A variable step size also addresses problems related to rapid fading of a radio channel where a mobile is traveling at high speed. Quickly changing fading conditions of the radio channel mean that the
15 transmit power to and from that mobile terminal must be adjusted rapidly using variable step sizes when such changes are detected. Even so, for a fast moving mobile user, it still may be quite difficult to compensate for fast fading. In that case, a 1 dB power step size may be too large or will only serve to increase power fluctuations, and it may be better to use small size power steps in this situation.

20 A drawback with sending variable step size power control commands is added overhead. In order to compensate for quickly changing transmission conditions, the variable step sizes must be transmit very frequently. In the example where a TPC command is sent every 0.625 msec time slot, a variable step size value is transmit 1,600 times per second. While frequently transmitted, variable step size commands enable the
25 transmit power control to track fast channel fading and other abrupt changes in transmission condition relatively well, there is a need to reduce undesirable signaling overhead associated with sending so much step size data and the associated loss of useable radio bandwidth for user traffic.

It is an object of the present invention to overcome the problems identified above, and in particular, to provide both efficient and effective power control in a mobile communications system.

It is an object of the present invention to achieve a power control technique
5 that adapts to rapidly changing radio transmission conditions and situations.

It is an object of the present invention to provide an adaptive power control technique that ensures a satisfactory quality of communication at a minimum level of interference.

It is an object of the present invention to provide an adaptive power control
10 technique with a minimal amount of control signaling overhead.

The present invention overcomes the identified problems and meets these and other objectives by efficiently and effectively controlling the transmit power of a radio transceiver. The value of a signal parameter detected from a signal received by the radio transceiver is compared with a desired signal parameter value, and a difference is
15 determined. A transmit power control command is sent to the radio transceiver and may instruct, for example, an increase or decrease in the level of radio transmit power. Associated with the transmit power control command is a power control indicator indicating which type of power control adjustment should be used by the radio transceiver depending upon the determined difference. For example, one or more flag bits may
20 accompany the power control command. Depending on a number of indicator bits employed, many different power control adjustments may be employed.

Other types of indicators with low overhead may also be employed. For example, different power control command bit patterns may be used. One pattern corresponds to a first type of power control adjustment and another pattern corresponds
25 to another type of power control adjustment. Different power control adjustment type messages may also be conveyed using other, non-power related control signaling messages frequently exchanged between the base and mobile stations. Moreover, any message that is sent in the normal operation and/or control of the base and mobile stations may be used

to convey power control adjustment type messages without significantly adding to the overhead.

In one example embodiment, the power control indicator includes a single flag bit. A first value indicates that a first type of power control adjustment should be used; the second value indicates that a second type of power control adjustment should be used. In any event, the power control indicator itself does not include specific details of the first or second type of power control adjustment. Because only the indicator is sent (and not the details), signaling overhead and bandwidth consumption related to frequently sent transmit power control commands are kept to a minimum. The details of the first and second power control adjustments are initially stored in the radio transceiver. Such details may be updated when desirable, but the frequency of such updating is likely to be infrequent.

The first and second type of power control adjustments may include a first and second power adjustment step size, where one step size might be used in one type of power adjustment situation and another step size might be used in another type of situation. Alternatively, the first and second type of power control adjustments might correspond to two different power control schemes for adjusting the transmit power of the radio transceiver. The invention may be implemented for “uplink” power control in a radio network node with the radio transceiver corresponding to one or more mobile stations. In addition, the invention may be implemented for the “downlink” direction in a mobile station with the radio transceiver corresponding to a base station in the radio network.

BRIEF DESCRIPTION OF THE DRAWINGS

The foregoing and other objects, features, and advantages of the invention will be apparent from the following description of preferred embodiments as well as illustrated in the accompanying drawings in which reference characters refer to the same

parts throughout the various views. The drawings are not necessarily to scale, emphasis instead being placed upon illustrating the principles of the invention.

Fig. 1 is a high level diagram of an example communications system in which the present invention may be employed;

5 Fig. 2 is a function block diagram of a radio network controller and a base station illustrated in Fig. 1;

Fig. 3 is a function block diagram illustrating a mobile station shown in Fig. 1 as well as fast and slow power control loops in an example power control scheme in a mobile communications system;

10 Fig. 4 illustrates a power control routine in accordance with one example embodiment of the present invention in flowchart format;

Fig. 5 illustrates an example format of a transmit power control message including a TPC command and a power control indicator;

15 Fig. 6 illustrates pictorially a high speed mobile station situation in which the present invention may be advantageously employed;

Fig. 7 illustrates pictorially a high power mobile interference problem that may be solved by the present invention; and

Fig. 8 illustrates another example embodiment of the present invention in flowchart form.

20

DETAILED DESCRIPTION OF THE DRAWINGS

In the following description, for purposes of explanation and not limitation, specific details are set forth, such as particular embodiments, procedures, techniques, etc., in order to provide a thorough understanding of the present invention. However, it will be apparent to one skilled in the art that the present invention may be practiced in other

embodiments that depart from these specific details. For example, the present invention may be applied advantageously to control the transmit power of mobile station transmissions on uplink/reverse direction radio channels. The present invention may also be advantageously employed to control the transmit power of a radio transceiver in a base station in a downlink/forward direction as well. In other instances, detailed descriptions of well-known methods, interfaces, devices, and signaling techniques are omitted so as not to obscure the description of the present invention with unnecessary detail.

A mobile radio cellular communications system 10 is shown in Fig. 1 and may be, for example, a CDMA or a wideband CDMA communications system. Radio network controllers (RNCs) 12 and 14 control various radio network functions including for example radio access bearer setup, diversity handover, etc. Radio network controller 12 is coupled to a plurality of base stations 16, 18, and 20. Radio network controller 14 is connected to base stations 22, 24, and 26. Each base station serves a geographical area referred to as a cell, and a cell may be divided into plural sectors. Base station 26 is shown as having five antenna sectors S1-S5. Each sector also has a corresponding cell area so that in this situation the base station serves five cells. The base stations are connected to their corresponding radio network controller by various means such as dedicated telephone lines, optical fiber links, microwave links, etc. Both radio network controllers 12 and 14 are connected with external networks such as the Public Switched Telephone Network (PSTN), the Internet, etc. through one or more core network nodes like a mobile switching center and/or a packet radio service node (not shown). The RNC directs mobile station calls via the appropriate base station(s).

In Fig. 1, two mobile stations 28 and 30 are shown communicating with plural base stations. Mobile station 28 communicates with base stations 16, 18, and 20, and mobile station 30 communicates with base stations 20 and 22. A control link between radio network controllers 12 and 14 permits diversity communications to/from mobile station 30 via base stations 20 and 22. Each radio communication channel established between the mobile station and a base station has an uplink component and a downlink component. Since multiple communications utilize the same radio frequencies in CDMA

communication, spreading codes along with other well-known CDMA techniques are used to distinguish between the various mobile station and base station communications. In this example embodiment, the term "channel" refers to a CDMA channel which, for any mobile station, is defined in terms of an RF frequency and a particular code sequence.

5 Additional details of a base station and a radio network controller are now provided in conjunction with Fig. 2. Each radio network controller (RNC) includes a network interface 52 for interfacing communications with various base stations. Within the RNC, the network interface 52 is connected to a controller 50 and to a diversity handover unit (DHO) 54. Diversity handover unit 54 performs numerous functions
10 required for establishing, maintaining, and dropping diversity connections such as diversity combining, diversity splitting, power control and other link related radio resource control algorithms. The RNC may include other control/functional units not necessary to the understanding of the invention.

Each base station includes a corresponding network interface 60 for
15 interfacing with the RNC. In addition, the base station includes a controller 62 connected to a one or more transceivers. In this example, a plurality of transceivers (TRX) 64, 66, 68, and 70 are shown coupled to a transmit power controller 72. Controller 62 controls the overall operation of the base station as well as the establishment, maintenance, and release of radio connections. Representative transceivers 64-70 are individually assigned to
20 specific communications with mobile stations. At least one transceiver is employed as a common control channel over which the base station transmits common signaling such as pilot, synchronization, or other broadcast signaling. Mobile stations within or near that base station's cell(s) monitor the common channel. Transmit power controller 72 performs power control operations. One or more carrier-to-interference ratio (CIR) detectors 74
25 (only one is shown for purposes of illustration) may be used to detect the CIR of signals received from mobiles. As mentioned in the background, other signal quality detectors may be employed, e.g., SIR, RSSI, etc.

Fig. 3 illustrates additional details of a mobile station shown in Fig. 4. The mobile station includes a controller 80 connected to a RAKE receiver 82, a transmit power

controller 88, a transmitter 90, and a CIR (or other signal quality) detector 100. The RAKE receiver 82 includes plural receivers 84 and 85 (there may be additional receivers as well) connected to a diversity combiner 86. One or more signal strength detectors (not shown) or similar detector(s) are employed in the mobile receiver 82 to detect the signal strength or other parameter of received signals. The transmissions from base stations are received as multipaths in the receivers 84 and 85, combining diversity combiner 86 and processed as one signal. Transmit power controller 88 determines the transmit power level (preferably as a carrier-to-interference ratio (CIR)) of the received, diversity-combined signal.

Fig. 3 also shows the fast power control loop between the mobile station and two base stations BS1 and BS2. Based upon CIR (or SIR) measurements of a received signal, the mobile station generates transmit power control commands sent to the base stations BS1 and BS2. Similarly, the base stations 1 and 2 send transmit power control commands to the mobile station based on CIR/SIR measurements made of signals received from that mobile station. The TPC commands may include one or more bits which indicate a desired increase in transmit power, a desired decrease in transmit power, or in some cases no change in transmit power. Of course, any number of bits or bit assignments is possible. In order to compensate for rapidly changing transmission conditions, these transmit power control commands are sent very frequently, and in one example embodiment, every 0.625 millisecond time slot or 1,600 times a second. Accordingly, this type of power control is referred to as fast, inner loop control. In addition, an optional, slow, outer control loop may also be employed in both uplink and downlink directions. The RNC monitors the quality reports provided from the base station and provides periodic updates with respect to target or reference CIR/SIR values.

A first example embodiment of the present invention is now described in conjunction with the power control routine (block 200) illustrated in Fig. 4. In this embodiment, the power control routine may be implemented in any type of radio transceiver and used to control the transmit power level in any direction, e.g., uplink and downlink. A controlling entity detects a signal quality parameter, such as carrier-to-

interference ratio (CIR), of a signal received from a controlled radio (block 202). The detected signal quality parameter is compared to a desired signal quality parameter, e.g., a target CIR, and a difference is determined (block 204). A transmit power control command is sent to the radio transceiver to either raise, lower, or make no change to the transceiver's current transmit power (block 206). A power control indicator is added to the transmit power control command, and in its simplest form, may be a single flag bit. The power control indicator indicates whether a first type or a second type of power control adjustment should be used depending upon the difference (block 208).

Fig. 5 illustrates a sample power control message format that may be used in accordance with an example embodiment of the present invention. A dedicated physical control channel (DPCCH) is shown which is divided into 72 frames corresponding to a 720 msec recycle time period. Each 10 msec frame is made up of 16 time slots each lasting 0.625 msec. Each DPCCH time slot may include a pilot field used for synchronization, a traffic power control (TPC) command which may include a command to increase, decrease, or maintain transmit power, a power control indicator or flag, and other bits. This type of transmit power control message may be sent in the uplink direction and downlink direction of the dedicated physical control channel.

While in the above example, the power control type indicator is appended to one or more transmit power control commands and may include a single flag bit to minimize signaling overhead, the power control adjustment indicator may be conveyed using other mechanisms. An important objective is to efficiently and effectively communicate the type of power control adjustment scheme to the radio transceiver without significantly increasing signaling overhead. One alternative example mechanism is to use different power control command bit patterns to be employed. One pattern might correspond to a first type of power control adjustment and another pattern might correspond to another type of power control adjustment. Different power control adjustment type messages may also be conveyed along with other, non-power related control signaling messages that are typically frequently exchanged between the base and mobile radio stations. Indeed, a power control adjustment type indicator may be sent with

any message transmitted in the normal operation and/or control of the radio receiver without significantly adding to the signaling overhead.

As one example of different types of power control adjustment, the first and second types of power control adjustments correspond to first and second step sizes. The first step size might be a typical step size change such as plus or minus 1 dB. The second
5 step size might correspond to a larger amount, e.g., 8 dB. As a result, when the difference between the detected and the desired signal quality parameter is large, the radio transceiver is immediately commanded to change its transmit power by the larger step size amount to compensate for this large disparity. More specifically, if the radio transceiver's transmit
10 power is significantly higher than that desired, the transceiver's transmit power can be immediately reduced to minimize the interference on surrounding radio communications. Alternatively, if the radio transceiver's detected signal quality is far below that desired, e.g., as a result of a building shadow or a strong fade, the radio transceiver's transmit power may be significantly increased to immediately improve the quality of communication to/from
15 that radio transceiver. However, in the latter situation, considerably more care is preferably taken when increasing the mobile's transmit power because of the potential for generating too much interference. It may be determined that only an incremental step size is used to increase power even though a larger step increase could be indicated.

In either of these situations, if only a small step size is used to gradually
20 increase or gradually decrease the radio transceiver's transmit power, the transmission conditions would be less than optimal for quite some time. In the first overpowered transmission situation, the radio transceiver disrupts and interferes with the communications of other provided transceivers which results in those transceivers increasing their transmit power in order to be adequately heard and possibly escalating into
25 a "party effect" situation. On the other extreme, if the radio transceiver's transmit power is much too low for too long, the radio connection may well be lost.

Another advantage of the fast and effective power control of the present invention is that it does not significantly increase the amount of overhead signaling to and from the radio transceiver. This is quite significant in fast transmit power control schemes

in which the transmit power control commands are transmitted every time slot in order to quickly adapt to changes in system conditions, e.g., 1,600 times per second. While the variable step size power adjustment value and other details may be communicated along with each transmit power control command, that information content adds considerable overhead in terms of numbers of bits that must be set and transmit over the radio interface. It also reduces the bandwidth available for user traffic. With the present invention, varying the step size and even the type of power control scheme employed may be accomplished simply by transmitting a single bit value with the transmit power control command resulting in only a small overhead increase and bandwidth decrease. Alternate existing messages or other techniques, like the few examples mentioned above, may also be used to convey this information without much increase in overhead. However, if very fast power control type adjustment is desired, transmitting an indicator with the normal power control command is preferred. On the other hand, if speed is less important, the indicator may be transmitted along with existing control signaling.

The first and second type of power control adjustment may also correspond to first and second types of power control adjustment schemes. For example, in the first type of power control adjustment scheme, the power adjustment is a change of 1 dB each time slot. In the second type of power adjustment control scheme, the first slot corresponds to an adjustment of 2 dB, the second time slot 2 db, the third time slot 4 dB, the fourth time slot 4 dB, the fifth time slot 8 dB, the next time slot 8dB, the next time slot 4 dB, the next time slot 4 dB and so forth. Table 1 shows an example:

Power control scheme	Slot 1	Slot 2	Slot 3	Slot 4	Slot 5	Slot 6	Slot 7	Slot 8
First scheme	1 dB	1 dB	1 dB	1 dB	1 dB	1 dB	1 dB	1 dB
Second scheme	2 dB	2 db	4 db	4 db	8 dB	8 dB	4 dB	4 dB

Of course, more than two power control schemes may be employed and selected using further bits, e.g., two power control indicator bits may be used to select one of four different control schemes.

In another example, assume that two redundant TPC bits are transmit every slot to increase reliability, e.g., “00” = lower power and “11” = raise power. Only two of the possible four combinations of these two bits are used. The other two combinations are then used to indicate two different power control adjustments. For example, “01” could
5 be used to indicate one type of power control adjustment and “10” to indicate another type of power control adjustment. To further increase the reliability, TPC bits may be collected over a number of consecutive slots.

Thus, rather than actually transmitting an actual power control scheme or an actual step size value by which the transmit power should be increased or decreased along
10 with each transmit power command (increase, decrease, or no change), the different power control schemes and different step size values may be pre-stored in or otherwise provided to the radio transceiver and appropriately referenced by the radio transceiver when the associated power control indicator is received. The cost of this very fast and flexible power control is the minimal signaling overhead associated with the one or more power control
15 indicator bits. Moreover, the different power control adjustment schemes or values (which require many more bits than a power control indicator) may be changed whenever necessary by an occasional control message transmitted to the radio receiver. However, because such changes only infrequently occur (i.e., much less frequently than the TPC commands are sent), those changes would not considerably increase overall overhead
20 signaling.

Two example situations where the present invention may be advantageously employed are now described in conjunction with Figs. 6 and 7. The following examples are described in the context of controlling the transmit power level of a mobile station transmitting in the uplink direction. Of course, the invention may also be employed to
25 control the transmit power of a base station transceiver transmitting in the downlink direction. In the downlink direction, the invention may be implemented in the radio network controller, in the base station, in both, or in some other radio network node.

Fig. 6 shows an example scenario 220 of a mobile station traveling at a high speed where the radio channel is rapidly changing and fast fading is occurring. Referring to equation (1) above, the gain factor G_f attributed to the fast fading changes significantly which changes the carrier-to-interference ratio significantly, rapidly, and unpredictably.

5 Because the mobile station is also traveling quickly in a vehicle, it may be difficult to fully compensate for each detected fast fade. Indeed, a 1 dB power step change may be too large, and by the time it is implemented at the mobile station, it may only exacerbate gain fluctuations rather than ameliorate the problem. In this particular scenario 220, it may be decided to use smaller power steps. Accordingly, an alternative power control scheme is

10 selected (by appropriately setting the power control flag) which provides very small power changes, e.g., less than 1 dB.

As the high speed mobile station approaches a temporary obstacle, such as a building, and moves to a location where the line of sight radio path between the mobile station and the base station is blocked, the detected CIR at the base station from the

15 mobile station dramatically decreases. In order to maintain a reasonable quality connection with the mobile station, a different power control indicator is transmitted from the base station to indicate that the mobile should increase its transmit power substantially using a different, larger step size to quickly adjust to the conditions in the blocked region and maintain the connection quality.

20 Fig. 7 illustrates an overpowered mobile transmission scenario 230 in which the present invention may be advantageously employed. A mobile station MS1 at time A is far away from a serving base station BSA with which it is currently communicating. Because of the far distance, it is transmitting at a high transmit power. At time B, mobile station MS1 has moved behind a building blocking the line of sight between MS1 and BSA.

25 This may cause an increase of an already high transmission power as the base station BSA tries to maintain the quality of connection with MS1 as it moves behind the building as just described in Fig. 6. Unfortunately, as MS1 rounds the corner of that building, it is quite near to another base station BSB at time B. Its transmit power is considerably

overpowered causing severe interference with the base station transmissions and with the transmissions of mobile stations MS4 and MS5 transmitting at a much lower power level. As soon as this high power transmission from MS1 is detected via base station BSB, an immediate transmit power control command is returned to MS1 to decrease its power. In addition, a power control indicator indicates that the amount of power decrease should be large. As a result, in only one or several time slots, the transmit power of MS1 is brought to a reasonable level thereby minimizing the interference with the other mobile communications with BSB. If only a standard, typical step size of 1 dB is employed, the degree and length of interference would be much more significant.

Fig. 8 illustrates a power control routine (block 250) in another example uplink embodiment of the present invention. Plural power control adjustment factors, procedures or schemes, comparison thresholds, etc. are either accessible by or provided to stored in a memory of the base station (and/or RNC or other radio network node) and one or more mobile stations (block 252). The base station detects at every time slot, (e.g., 0.625 milliseconds or 1,600 times per second), the CIR (or other signal quality parameter) of the signal received from the mobile station (block 254). The received CIR is compared with the desired CIR, and the base station determines the CIR difference and polarity, (i.e., whether the received CIR is too high or too low) (block 256). The CIR difference is then compared to one or more previously stored CIR thresholds to determine which of plural power control adjustment factors, procedures, or schemes, etc. should be used by the mobile station to adjust its current transmit power level (block 258). In addition, the value of the power control indicator is set according to the determined power control adjustment factor, procedure, or scheme (block 260). The set power control indicator value is sent along with the transmit power control command to the mobile station (block 262). The mobile station receives and detects the TPC command and power control indicator and makes the appropriate adjustment to its transmit power based thereon. The power control adjustment factors, procedures, or schemes, comparison thresholds, etc. may be optionally changed and updated in a memory of or accessible by the appropriate mobile and base stations (block 264).

While the present invention has been described with respect to a particular embodiment, those skilled in the art will recognize that the present invention is not limited to the specific example embodiments described and illustrated herein. Different formats, embodiments, and adaptations besides those shown and described as well as many
5 modifications, variations, and equivalent arrangements may also be used to implement the invention. Alternatively, a power control indicator may be communicated using techniques other than adding one or more flag bits to a fast transmit power control message to effect a change in power control type as long as signaling overhead is not significantly increased. Accordingly, it is intended that the invention be limited only by the scope of the claims
10 appended hereto.

WHAT IS CLAIMED IS:

1. A method for controlling the transmit power of a radio transceiver, comprising:
 - detecting a parameter value of a signal received from the radio transceiver;
 - 5 comparing the detected signal parameter value with a desired signal parameter value and determining a difference;
 - sending a transmit power control command to the radio transceiver; and
 - sending a power control indicator associated with the transmit power control command indicating whether a first or a second type of power control adjustment should
 - 10 be used by the radio transceiver depending on the difference.
2. The method in claim 1, wherein the power control indicator includes only a single flag bit.
3. The method in claim 1, wherein the power control indicator does not include the first or second type of power control adjustments.
- 15 4. The method in claim 1, wherein the method is implemented in a radio network node and the radio transceiver is a mobile station.
5. The method in claim 1, wherein the method is implemented in a mobile station and the radio transceiver is a base station.
6. The method in claim 1, wherein the signal parameter is a radio carrier-to-interference ratio (CIR).
- 20 7. The method in claim 1, wherein the transmit power control command instructs the radio transceiver to increase, decrease, or maintain transmit power.
8. The method in claim 1, wherein the first and second types of power control adjustment determine an amount by which the radio transceiver adjusts its transmit power.
- 25 9. The method in claim 8, wherein the first type of power control adjustment is a first amount to be used under a first type of transmission condition, and wherein the

second type of power control adjustment is a second amount to be used under a second type of transmission condition.

10. The method in claim 9, wherein the first amount is a default amount and the second amount is larger or smaller than the default amount depending on the transmission
5 condition.

11. The method in claim 1, further comprising:
providing the radio transceiver once or at a first frequency, the first and second
power control adjustments,
wherein the transmit power control commands are sent at a second frequency
10 greater than the first frequency.

12. The method in claim 1, wherein transmit power control commands instruct
the radio transceiver to increase or to decrease transmit power, and the power control
indicator is a flag bit which at a first value indicates a first amount to increase or decrease
transmit power and at a second value indicates a second amount to increase or decrease
15 transmit power.

13. The method in claim 1, wherein the first and second type of power control
adjustments include a first and second power control scheme, respectively.

14. The method in claim 1, wherein the power control indicator corresponds to
one of different patterns of the transmit power control command.

20 15. The method in claim 1, wherein the power control indicator is included with
the transmit power control command.

16. The method in claim 1, wherein the power control indicator is included with
a control message other than the transmit power control command frequently sent to the
radio transceiver.

25 17. The method in claim 1, wherein the sending of the power control indicator is
performed with minimal increase in signaling overhead.

18. A method for controlling the transmit power of a mobile station transmitting to a radio network, comprising:
- detecting at a first frequency a signal-to-interference parameter value of a signal received from the mobile radio;
 - 5 comparing the detected signal-to-interference parameter value with a desired signal-to-interference parameter value and determining a difference;
 - comparing the difference with a threshold;
 - sending a transmit power control command to the mobile station to possibly increase or decrease its transmit power depending on the difference; and
 - 10 associating with the transmit power control command a power control indicator indicating that a first type of power control adjustment should be used by the mobile station if the difference is less than the threshold and that a second type of power control adjustment should be used by the mobile station if the difference is greater than or equal to the threshold.
- 15 19. The method in claim 18, further comprising:
- providing to the mobile station either once or at a second frequency less than the first frequency the first and second types of power control adjustments.
- 20 20. The method in claim 18, wherein transmit power control commands and the power control indicator are sent over a slotted channel, and the first frequency corresponds to once a time slot.
21. The method in claim 18, wherein the first and second types of adjustments include first and second power adjustment control procedures.
22. The method in claim 18, wherein the first and second types of adjustments include first and second power adjustment step sizes.
- 25 23. The method in claim 18, wherein the difference is compared to plural thresholds, each threshold having a corresponding type of power control adjustment.

24. The method in claim 18, wherein the power control indicator includes only a single flag bit.

25. The method in claim 18, wherein the power control indicator does not include the first or second type of power control adjustments.

5 26. A mobile transceiver capable of communicating with a radio network, comprising:
a transceiver including a radio transmitter and a radio receiver; and
a controller having first and second types of power control adjustments and receiving from the radio network transmit power control commands to increase or
10 decrease a transmit power level of the transmitter and a power control indicator indicating whether the first or second type of power control adjustment should be employed,
wherein the controller adjusts the transmit power level of the transmitter using one of the first and second types of power control adjustments depending on a value of the power control indicator.

15 27. The mobile transceiver in claim 26, wherein the received power control indicator is associated with one of the transmit power control commands

28. The mobile transceiver in claim 26, wherein the power control indicator includes only a single flag bit.

20 29. The mobile transceiver in claim 26, wherein the power control indicator does not include the first or second type of power control adjustments.

30. The mobile transceiver in claim 26, wherein the mobile transceiver receives from radio network either once or at a second frequency less than the first frequency the first and second types of power control adjustments.

25 31. The mobile transceiver in claim 26, wherein transmit power control commands and the power control indicator are sent over a slotted channel, and the first frequency corresponds to once a time slot.

32. The mobile transceiver in claim 26, wherein the first and second types of adjustments include first and second power adjustment control procedures.

33. The mobile transceiver in claim 26, wherein the first and second types of adjustments include first and second power adjustment step sizes.

5 34. A radio network node sending power control commands to a radio transceiver, comprising:
a detector detecting a signal parameter value of a signal received from the radio transceiver;
a comparator comparing the detected signal parameter value with a desired signal
10 parameter value and determining a difference; and
a transmitter transmitting a transmit power control command to the radio transceiver and along with a power control indicator indicating whether a first or a second type of power control adjustment should be used by the radio transceiver depending on the difference.

15 35. The radio network node in claim 34, wherein the radio network node includes a base station.

36. The radio network node in claim 34, wherein the radio network node includes a radio network controller.

20 37. The radio network node in claim 34, wherein the a power control indicator corresponds to a flag bit and does not include the first or second type of power control adjustments.

38. The radio network node in claim 34, wherein the signal parameter is a carrier-to-interference ratio (CIR).

25 39. The radio network node in claim 34, wherein the transmit power control command instructs the radio transceiver to increase or decrease transmit power, and wherein the first and second types of power control adjustment determine an amount by which the radio transceiver adjusts its transmit power.

40. The radio network node in claim 34, wherein the first type of power control adjustment is a first amount to be used under a first type of transmission condition, and wherein the second type of power control adjustment is a second amount to be used under a second type of transmission condition.

5 41. The radio network node in claim 34, further comprising:
means for providing the radio transceiver once or at a first frequency, the first and second power control adjustments,
wherein the transmitter transmits the transmit power control commands at a second frequency greater than the first frequency.

10 42. The radio network node in claim 34, wherein the power control indicator corresponds to one of different patterns of the transmit power control command.

43. The radio network node in claim 34, wherein the power control indicator is included with the transmit power control command.

15 44. The radio network node in claim 34, wherein the power control indicator is included with a control message other than the transmit power control command frequently sent to the radio transceiver.

45. The radio network node in claim 34, wherein the sending of the power control indicator is performed with minimal increase in signaling overhead.

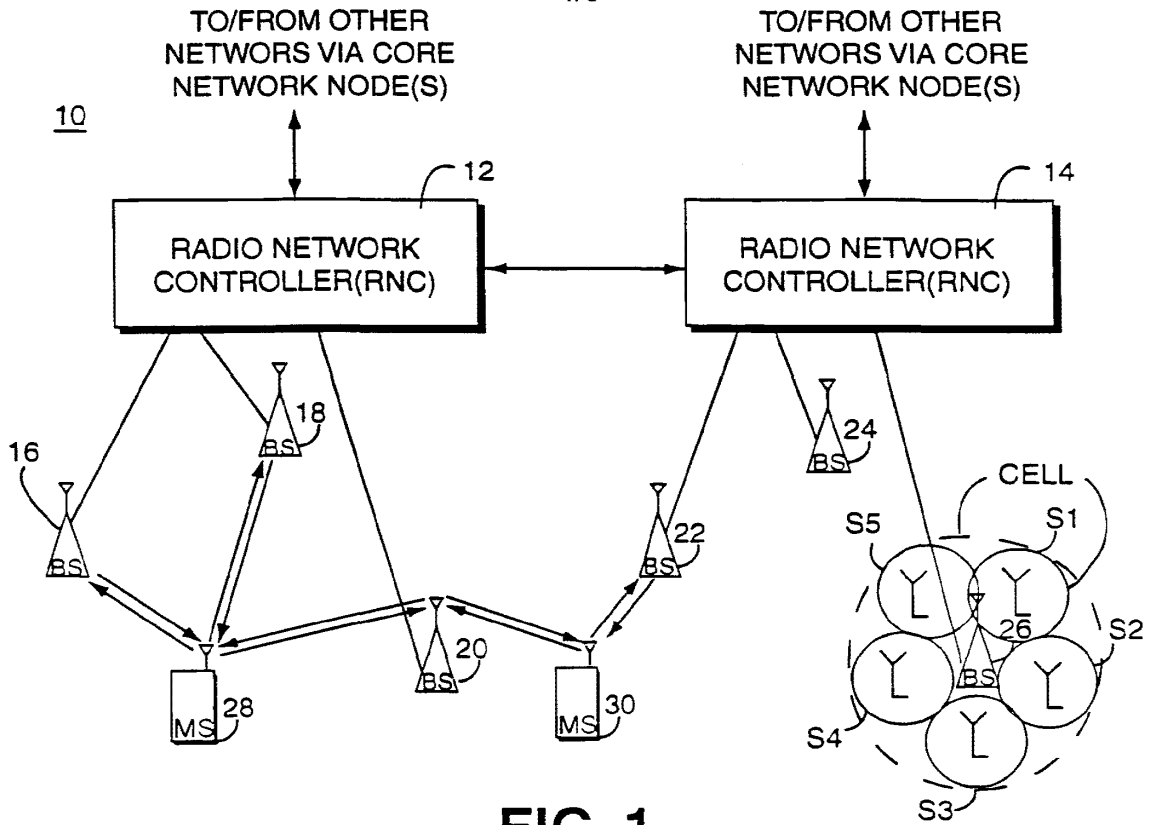

FIG. 1

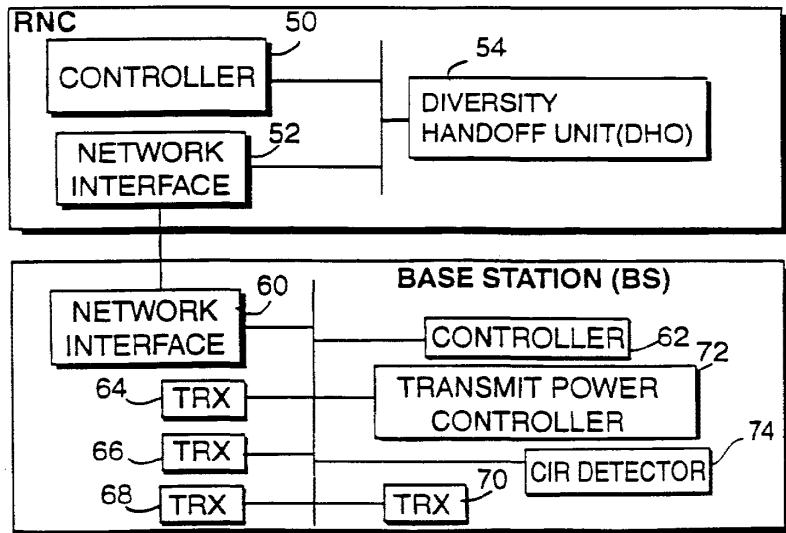

FIG. 2

2/6

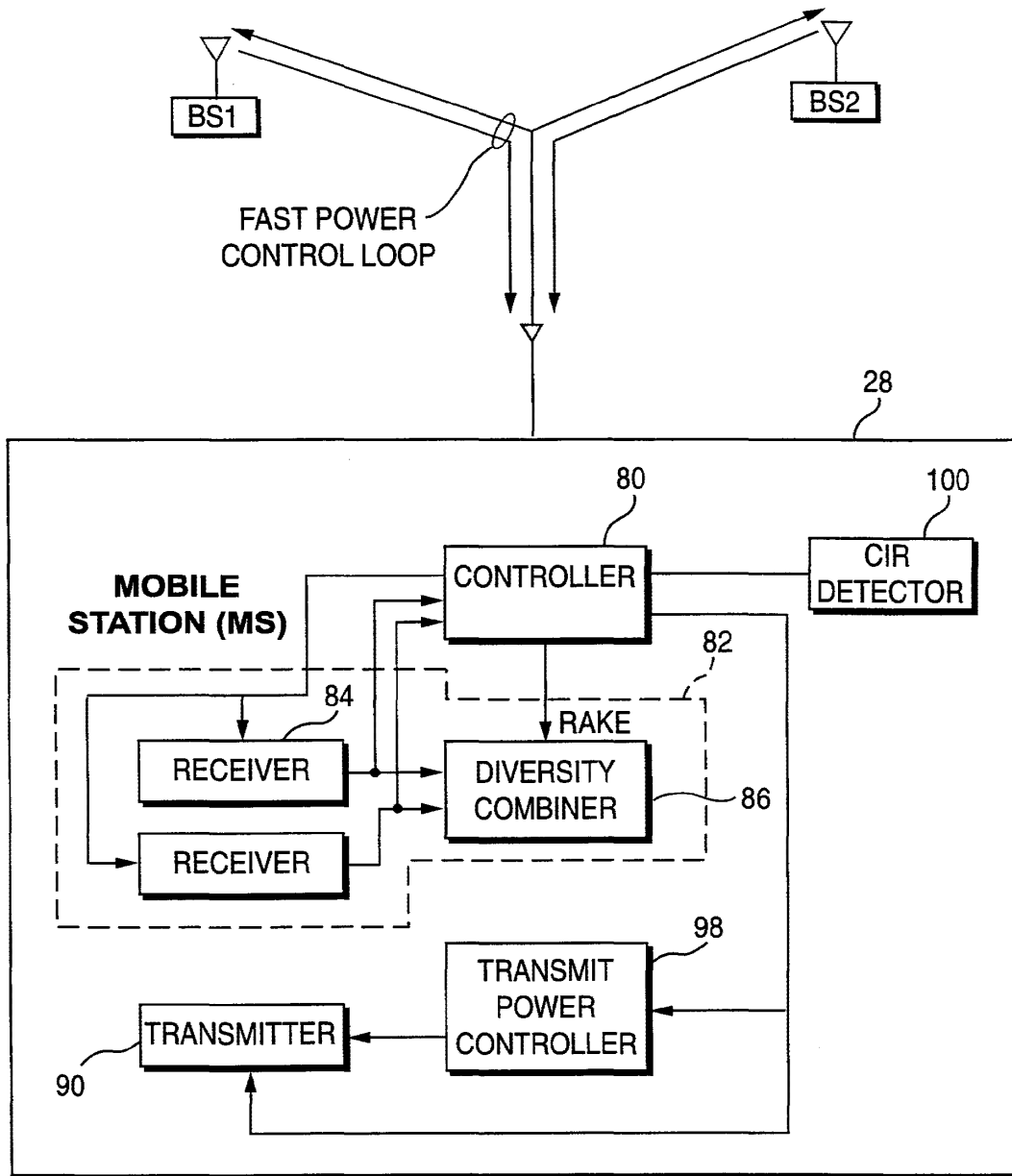

FIG. 3

3/6

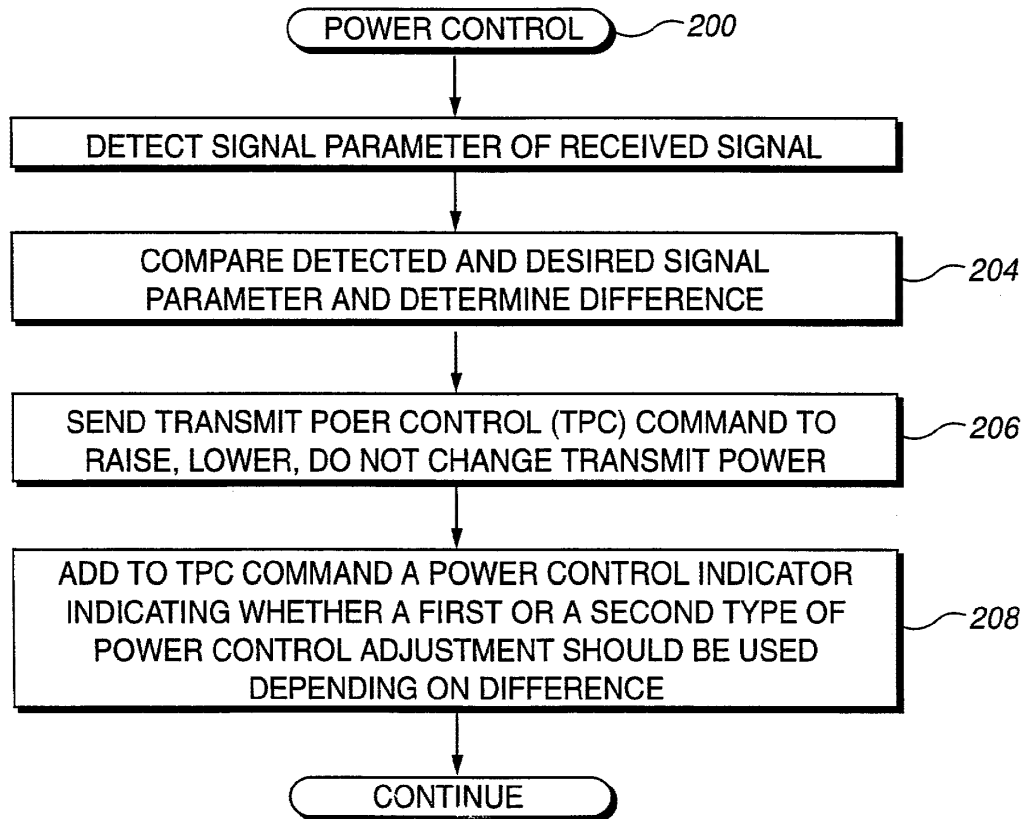

Fig. 4

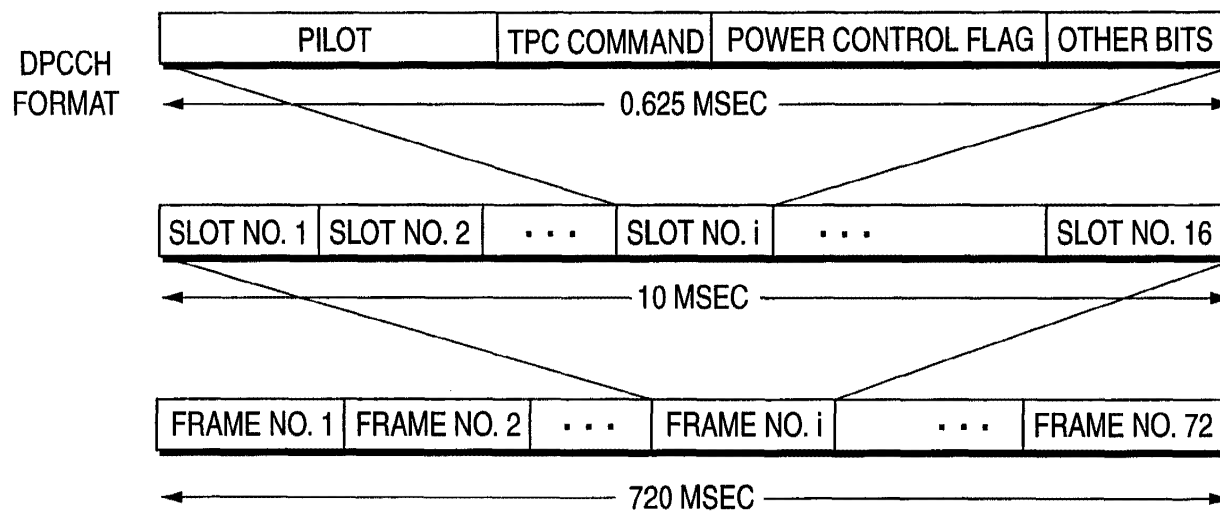

Fig. 5

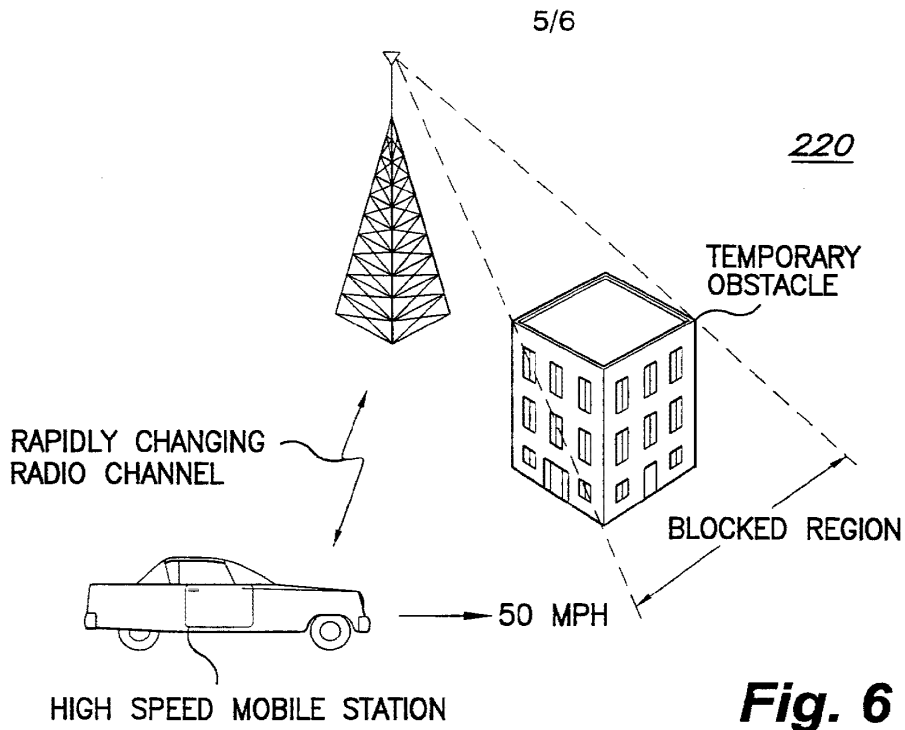

Fig. 6

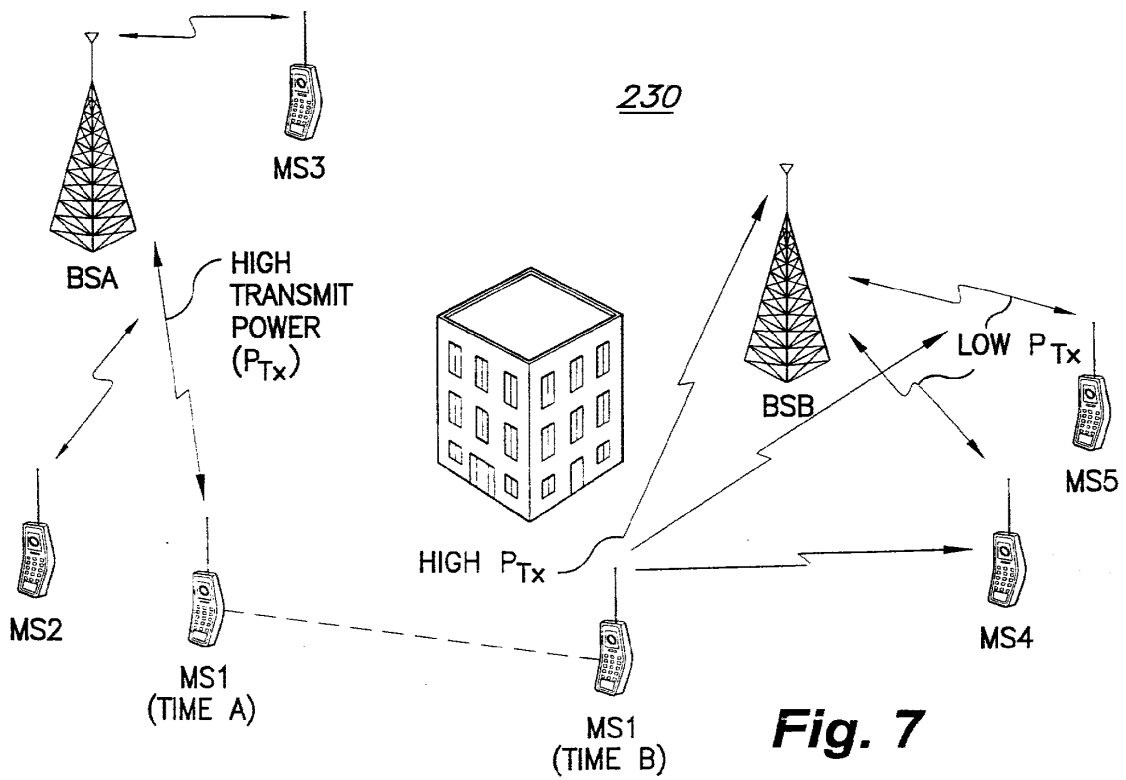

Fig. 7

6/6

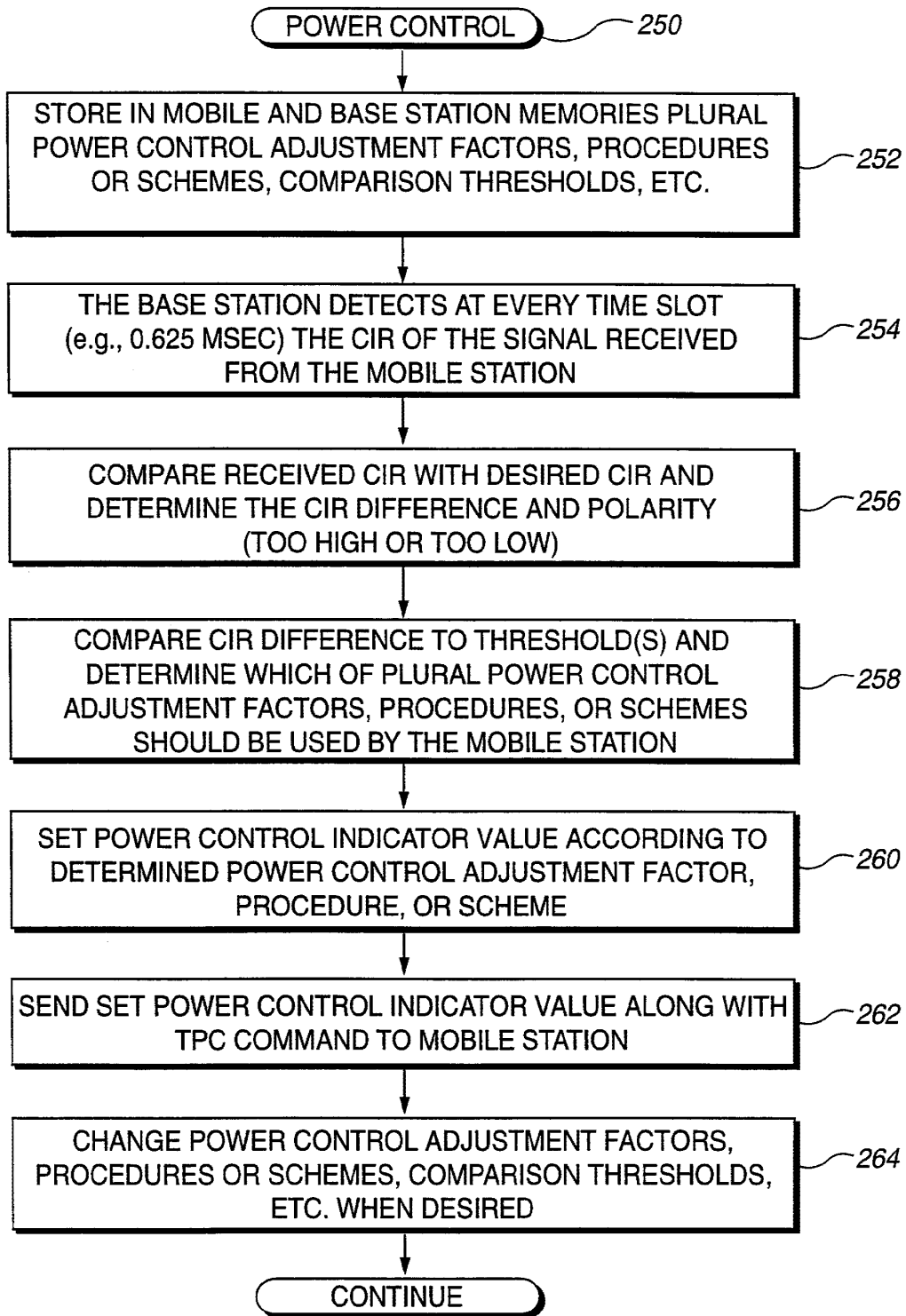

Fig. 8

INTERNATIONAL SEARCH REPORT

International Application No
PCT/SE 00/00645

A. CLASSIFICATION OF SUBJECT MATTER IPC 7 H04B7/005				
According to International Patent Classification (IPC) or to both national classification and IPC				
B. FIELDS SEARCHED Minimum documentation searched (classification system followed by classification symbols) IPC 7 H04B				
Documentation searched other than minimum documentation to the extent that such documents are included in the fields searched				
Electronic data base consulted during the international search (name of data base and, where practical, search terms used) EPO-Internal, WPI Data, PAJ, INSPEC				
C. DOCUMENTS CONSIDERED TO BE RELEVANT				
Category *	Citation of document, with indication, where appropriate, of the relevant passages	Relevant to claim No.		
X A	WO 99 08398 A (QUALCOMM INC) 18 February 1999 (1999-02-18) * abstract * page 5, line 19 -page 6, line 19 page 10, line 36 -page 11, line 4 page 16, line 38 -page 17, line 31 page 19, line 34 -page 20, line 25 claim 1; figures 2,5,6,8,9	1,7-10, 12-14 18,26,34		
A	WO 97 26716 A (NOKIA TELECOMMUNICATIONS OY ;NOKIA MOBILE PHONES LTD (FI); SAARIO) 24 July 1997 (1997-07-24) page 2, line 17 - line 24 page 3, line 18 - line 29 page 4, line 3 - line 27 page 6, line 17 - line 27 page 10, line 3 - line 25 figures 1,2	1,18,26, 34		
--- /---				
<input checked="" type="checkbox"/> Further documents are listed in the continuation of box C.				
<input checked="" type="checkbox"/> Patent family members are listed in annex.				
* Special categories of cited documents :				
<table style="width: 100%; border: none;"> <tr> <td style="width: 50%; border: none;"> *A* document defining the general state of the art which is not considered to be of particular relevance *E* earlier document but published on or after the international filing date *L* document which may throw doubts on priority claim(s) or which is cited to establish the publication date of another citation or other special reason (as specified) *O* document referring to an oral disclosure, use, exhibition or other means *P* document published prior to the international filing date but later than the priority date claimed </td> <td style="width: 50%; border: none;"> *T* later document published after the international filing date or priority date and not in conflict with the application but cited to understand the principle or theory underlying the invention *X* document of particular relevance; the claimed invention cannot be considered novel or cannot be considered to involve an inventive step when the document is taken alone *Y* document of particular relevance; the claimed invention cannot be considered to involve an inventive step when the document is combined with one or more other such documents, such combination being obvious to a person skilled in the art. *&* document member of the same patent family </td> </tr> </table>			*A* document defining the general state of the art which is not considered to be of particular relevance *E* earlier document but published on or after the international filing date *L* document which may throw doubts on priority claim(s) or which is cited to establish the publication date of another citation or other special reason (as specified) *O* document referring to an oral disclosure, use, exhibition or other means *P* document published prior to the international filing date but later than the priority date claimed	*T* later document published after the international filing date or priority date and not in conflict with the application but cited to understand the principle or theory underlying the invention *X* document of particular relevance; the claimed invention cannot be considered novel or cannot be considered to involve an inventive step when the document is taken alone *Y* document of particular relevance; the claimed invention cannot be considered to involve an inventive step when the document is combined with one or more other such documents, such combination being obvious to a person skilled in the art. *&* document member of the same patent family
A document defining the general state of the art which is not considered to be of particular relevance *E* earlier document but published on or after the international filing date *L* document which may throw doubts on priority claim(s) or which is cited to establish the publication date of another citation or other special reason (as specified) *O* document referring to an oral disclosure, use, exhibition or other means *P* document published prior to the international filing date but later than the priority date claimed	*T* later document published after the international filing date or priority date and not in conflict with the application but cited to understand the principle or theory underlying the invention *X* document of particular relevance; the claimed invention cannot be considered novel or cannot be considered to involve an inventive step when the document is taken alone *Y* document of particular relevance; the claimed invention cannot be considered to involve an inventive step when the document is combined with one or more other such documents, such combination being obvious to a person skilled in the art. *&* document member of the same patent family			
Date of the actual completion of the international search <p style="text-align: center;">16 August 2000</p>		Date of mailing of the international search report <p style="text-align: center;">24/08/2000</p>		
Name and mailing address of the ISA European Patent Office, P.B. 5818 Patentlaan 2 NL - 2280 HV Rijswijk Tel. (+31-70) 340-2040, Tx. 31 651 epo nl, Fax: (+31-70) 340-3016		Authorized officer <p style="text-align: center;">López Márquez, T</p>		

INTERNATIONAL SEARCH REPORT

Int: Jonal Application No
PCT/SE 00/00645

C.(Continuation) DOCUMENTS CONSIDERED TO BE RELEVANT		
Category *	Citation of document, with indication, where appropriate, of the relevant passages	Relevant to claim No.
A	EP 0 682 419 A (NIPPON TELEGRAPH & TELEPHONE) 15 November 1995 (1995-11-15) column 4, line 49 -column 6, line 23 figures 4-6	1,18,26, 34
A	US 5 710 982 A (MARQUART ROBERT CARROLL ET AL) 20 January 1998 (1998-01-20) column 1, line 50 -column 2, line 17 column 7, line 16 -column 8, line 33 claim 1; figures 4,5	1,18,26, 34

1

INTERNATIONAL SEARCH REPORT

Information on patent family members

International Application No
PCT/SE 00/00645

Patent document cited in search report	A	Publication date		Patent family member(s)	Publication date
WO 9908398	A	18-02-1999	AU	8776798 A	01-03-1999
WO 9726716	A	24-07-1997	FI	960276 A	20-07-1997
			AU	716337 B	24-02-2000
			AU	1446197 A	11-08-1997
			EP	0815656 A	07-01-1998
			JP	11506891 T	15-06-1999
			NO	974312 A	18-11-1997
EP 0682419	A	15-11-1995	JP	2974274 B	10-11-1999
			JP	8032514 A	02-02-1996
			CA	2149096 A,C	13-11-1995
			CN	1126929 A	17-07-1996
			US	5590409 A	31-12-1996
US 5710982	A	20-01-1998	US	5790940 A	04-08-1998

Electronic Patent Application Fee Transmittal

Application Number:				
Filing Date:				
Title of Invention:	Power Headroom Reporting Method			
First Named Inventor/Applicant Name:	Juergen MICHEL			
Filer:	Mark F. Harrington/Ann Okrentowich			
Attorney Docket Number:	863.0156.U1(US)			
Filed as Large Entity				
U.S. National Stage under 35 USC 371 Filing Fees				
Description	Fee Code	Quantity	Amount	Sub-Total in USD(\$)
Basic Filing:				
National Stage Fee	1631	1	330	330
Natl Stage Search Fee - Report provided	1642	1	430	430
National Stage Exam - all other cases	1633	1	220	220
Pages:				
Claims:				
Claims in excess of 20	1615	19	52	988
Independent claims in excess of 3	1614	3	220	660
Miscellaneous-Filing:				

Description	Fee Code	Quantity	Amount	Sub-Total in USD(\$)
Petition:				
Patent-Appeals-and-Interference:				
Post-Allowance-and-Post-Issuance:				
Extension-of-Time:				
Miscellaneous:				
Total in USD (\$)				2628

Electronic Acknowledgement Receipt

EFS ID:	6667310
Application Number:	12665427
International Application Number:	PCT/FI08/50384
Confirmation Number:	1011
Title of Invention:	Power Headroom Reporting Method
First Named Inventor/Applicant Name:	Juergen MICHEL
Customer Number:	29683
Filer:	Mark F. Harrington/Ann Okrentowich
Filer Authorized By:	Mark F. Harrington
Attorney Docket Number:	863.0156.U1(US)
Receipt Date:	18-DEC-2009
Filing Date:	
Time Stamp:	13:00:21
Application Type:	U.S. National Stage under 35 USC 371

Payment information:

Submitted with Payment	yes
Payment Type	Deposit Account
Payment was successfully received in RAM	\$2628
RAM confirmation Number	10266
Deposit Account	501924
Authorized User	

File Listing:

Document Number	Document Description	File Name	File Size(Bytes)/ Message Digest	Multi Part /.zip	Pages (if appl.)
-----------------	----------------------	-----------	-------------------------------------	------------------	------------------

1	Transmittal of New Application	ApplicationTransmittal.pdf	159019	no	3
			e8b9e8c672086584ea7341ecf5ad75fccbaa aaba		
Warnings:					
Information:					
2	Preliminary Amendment	PrelimAmend.pdf	319579	no	8
			232803ecad314ddfd4c2c0bb308e2f6da01c1 97ab		
Warnings:					
Information:					
3	Information Disclosure Statement (IDS) Filed (SB/08)	IDS.pdf	519025	no	14
			119bfff5daa54e88027fd4b110e9d4b92c59 7866		
Warnings:					
Information:					
This is not an USPTO supplied IDS fillable form					
4	Specification	WO2008155469.pdf	878664	no	25
			6aa257241057c09dc07fc24efc463d4f976b 52bc		
Warnings:					
Information:					
5	Foreign Reference	EP1311076A1.pdf	747745	no	13
			c3f663ab04a19ef1d2cfeb21a69dc645d76d cc0a		
Warnings:					
Information:					
6	Foreign Reference	EP1628413A2.pdf	1259042	no	26
			40e74a8443fe99de5a2d4319f6e80f7896a5 6b71		
Warnings:					
Information:					
7	Foreign Reference	WO0003499A1.pdf	1048061	no	27
			000ff76960970a97976774e897798cd4d88 7429		
Warnings:					
Information:					
8	Foreign Reference	WO0062441A1.pdf	1577901	no	37
			a03f55ceabd7da64820bd8f79eef63902d41 0ff6		
Warnings:					
Information:					
9	Fee Worksheet (PTO-875)	fee-info.pdf	38231	no	2
			12ac377210f01b301b51310ccea4f8555b56 892f		

Warnings:	
Information:	
Total Files Size (in bytes):	6547267
<p>This Acknowledgement Receipt evidences receipt on the noted date by the USPTO of the indicated documents, characterized by the applicant, and including page counts, where applicable. It serves as evidence of receipt similar to a Post Card, as described in MPEP 503.</p> <p><u>New Applications Under 35 U.S.C. 111</u> If a new application is being filed and the application includes the necessary components for a filing date (see 37 CFR 1.53(b)-(d) and MPEP 506), a Filing Receipt (37 CFR 1.54) will be issued in due course and the date shown on this Acknowledgement Receipt will establish the filing date of the application.</p> <p><u>National Stage of an International Application under 35 U.S.C. 371</u> If a timely submission to enter the national stage of an international application is compliant with the conditions of 35 U.S.C. 371 and other applicable requirements a Form PCT/DO/EO/903 indicating acceptance of the application as a national stage submission under 35 U.S.C. 371 will be issued in addition to the Filing Receipt, in due course.</p> <p><u>New International Application Filed with the USPTO as a Receiving Office</u> If a new international application is being filed and the international application includes the necessary components for an international filing date (see PCT Article 11 and MPEP 1810), a Notification of the International Application Number and of the International Filing Date (Form PCT/RO/105) will be issued in due course, subject to prescriptions concerning national security, and the date shown on this Acknowledgement Receipt will establish the international filing date of the application.</p>	

(19) World Intellectual Property Organization
International Bureau



(43) International Publication Date
24 December 2008 (24.12.2008)

PCT

(10) International Publication Number
WO 2008/155469 A1

- (51) International Patent Classification:
H04B 7/005 (2006.01)
- (21) International Application Number:
PCT/FI2008/050384
- (22) International Filing Date: 23 June 2008 (23.06.2008)
- (25) Filing Language: English
- (26) Publication Language: English
- (30) Priority Data:
60/936,649 20 June 2007 (20.06.2007) US
- (71) Applicant (for all designated States except US): **NOKIA SIEMENS NETWORKS OY** [FI/FI]; Karaportti 3, FI-02610 Espoo (FI).

(DE). **PEDERSEN, Klaus Ingemann** [DK/DK]; Laesogade 9, 3 th, DK-9000 Aalborg (DK). **ROSA, Claudio** [IT/DK]; Krebsen 14, DK-8900 Randers (DK).

(74) Agent: **KOLSTER OY AB**; Iso Roobertinkatu 23, P.O. Box 148, FI-00121 Helsinki (FI).

(81) Designated States (unless otherwise indicated, for every kind of national protection available): AE, AG, AL, AM, AO, AT, AU, AZ, BA, BB, BG, BH, BR, BW, BY, BZ, CA, CH, CN, CO, CR, CU, CZ, DE, DK, DM, DO, DZ, EC, EE, EG, ES, FI, GB, GD, GE, GH, GM, GT, HN, HR, HU, ID, IL, IN, IS, JP, KE, KG, KM, KN, KP, KR, KZ, LA, LC, LK, LR, LS, LT, LU, LY, MA, MD, ME, MG, MK, MN, MW, MX, MY, MZ, NA, NG, NI, NO, NZ, OM, PG, PH, PL, PT, RO, RS, RU, SC, SD, SE, SG, SK, SL, SM, SV, SY, TJ, TM, TN, TR, TT, TZ, UA, UG, US, UZ, VC, VN, ZA, ZM, ZW.

- (72) Inventors; and
- (75) Inventors/Applicants (for US only): **MICHEL, Jürgen** [DE/DE]; Sebastian-Bauer-Strasse 35, 81737 München

(84) Designated States (unless otherwise indicated, for every kind of regional protection available): ARIPO (BW, GH, GM, KE, LS, MW, MZ, NA, SD, SL, SZ, TZ, UG, ZM,

[Continued on next page]

(54) Title: POWER HEADROOM REPORTING METHOD

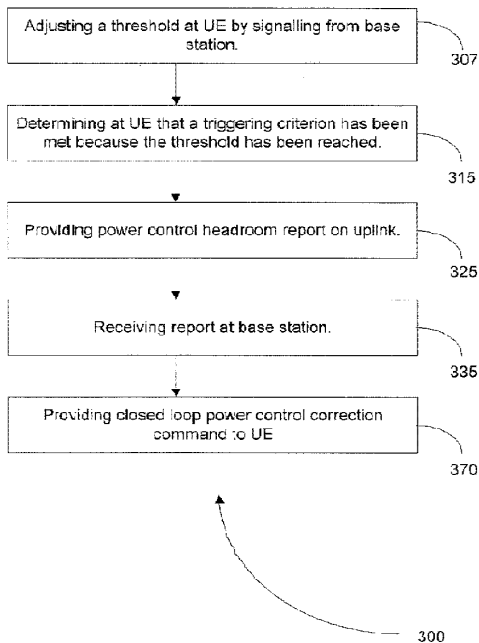

(57) Abstract: A method, user equipment, network device, and software product enable a user equipment to determine that at least one of several triggering criterion have been met, in which case the user equipment provides a power control headroom report on an uplink from the user equipment. The triggering criterion includes a threshold having been reached, and the threshold is adjustable via a signal to the user equipment from a base station (such as an eNodeB).

FIG. 3

WO 2008/155469 A1



ZW), Eurasian (AM, AZ, BY, KG, KZ, MD, RU, TJ, TM),
European (AT, BE, BG, CH, CY, CZ, DE, DK, EE, ES, FI,
FR, GB, GR, HR, HU, IE, IS, IT, LT, LU, LV, MC, MT, NL,
NO, PL, PT, RO, SE, SI, SK, TR), OAPI (BF, BJ, CF, CG,
CI, CM, GA, GN, GQ, GW, ML, MR, NE, SN, TD, TG).

- *before the expiration of the time limit for amending the claims and to be republished in the event of receipt of amendments*
- *the filing date of the international application is within two months from the date of expiration of the priority period*

Published:

- *with international search report*

POWER HEADROOM REPORTING METHOD

Field of the Invention

5 The invention relates to the field of wireless telecommunications. More particularly, the present invention pertains to power control.

Background of the Invention

10 The telecommunications industry is in the process of developing a new generation of flexible and affordable communications that includes high-speed access while also supporting broadband services. Many features of the third generation (3G) mobile telecommunications system have already been established, but many other features have yet to be perfected. The Third Generation Partnership Project (3GPP) has been pivotal in these developments.

15 One of the systems within the third generation of mobile communications is the Universal Mobile Telecommunications System (UMTS) which delivers voice, data, multimedia, and wideband information to stationary as well as mobile customers. UMTS is designed to accommodate increased system capacity and data capability. Efficient use of the electromagnetic spectrum is vital in UMTS. It is known that spectrum efficiency can be attained using frequency division duplex (FDD) or using time division duplex (TDD)
20 schemes. Space division duplex (SDD) is a third duplex transmission method used for wireless telecommunications.

 As can be seen in **FIG. 1**, the UMTS architecture consists of user equipment **102** (UE), the UMTS Terrestrial Radio Access Network **104** (UTRAN), and the Core Network **126** (CN). The air interface between the UTRAN and the UE is called Uu, and the interface
25 between the UTRAN and the Core Network is called Iu.

 High-Speed Downlink Packet Access (HSDPA) and High-Speed Uplink Packet Access (HSUPA) are further 3G mobile telephony protocols in the High-Speed Packet Access (HSPA) family. They provide a smooth evolutionary path for UMTS-based networks allowing for higher data transfer speeds.

Evolved UTRAN (EUTRAN) is a more recent project than HSPA, and is meant to take 3G even farther into the future. EUTRAN is designed to improve the UMTS mobile phone standard in order to cope with various anticipated requirements. EUTRAN is frequently indicated by the term Long Term Evolution (LTE), and is also associated with terms like System Architecture Evolution (SAE). One target of EUTRAN is to enable all internet protocol (IP) systems to efficiently transmit IP data. The system will have only use a PS (packet switched) domain for voice and data calls, i.e. the system will contain Voice Over Internet Protocol (VoIP).

Information about LTE can be found in 3GPP TS 36.300 (V8.0.0, March 2007), *Evolved Universal Terrestrial Radio Access (E-UTRA) and Evolved Universal Terrestrial Radio Access Network (E-UTRAN) – Overall description; Stage 2 (Release 8)*, which is incorporated herein by reference in its entirety. UTRAN and EUTRAN will now be described in some further detail, although it is to be understood that especially E-UTRAN is evolving over time.

The UTRAN consists of a set of Radio Network Subsystems **128** (RNS), each of which has geographic coverage of a number of cells **110** (C), as can be seen in **FIG. 1**. The interface between the subsystems is called *Iur*. Each Radio Network Subsystem **128** (RNS) includes a Radio Network Controller **112** (RNC) and at least one Node B **114**, each Node B having geographic coverage of at least one cell **110**. As can be seen from Figure 1, the interface between an RNC **112** and a Node B **114** is called *Iub*, and the *Iub* is hard-wired rather than being an air interface. For any Node B **114** there is only one RNC **112**. A Node B **114** is responsible for radio transmission and reception to and from the UE **102** (Node B antennas can typically be seen atop towers or preferably at less visible locations). The RNC **112** has overall control of the logical resources of each Node B **114** within the RNS **128**, and the RNC **112** is also responsible for handover decisions which entail switching a call from one cell to another or between radio channels in the same cell.

In UMTS radio networks, a UE can support multiple applications of different qualities of service running simultaneously. In the MAC layer, multiple logical channels can be

5 multiplexed to a single transport channel. The transport channel can define how traffic from logical channels is processed and sent to the physical layer. The basic data unit exchanged between MAC and physical layer is called the Transport Block (TB). It is composed of an RLC PDU and a MAC header. During a period of time called the transmission time interval (TTI), several transport blocks and some other parameters are delivered to the physical layer.

10 Generally speaking, a prefix of the letter "E" in upper or lower case signifies the Long Term Evolution (LTE). The E-UTRAN consists of eNBs (E-UTRAN Node B), providing the E-UTRA user plane (RLC/MAC/PHY) and control plane (RRC) protocol terminations towards the UE. The eNBs interface to the access gateway (aGW) via the S1, and are interconnected via the X2.

15 An example of the E-UTRAN architecture is illustrated in FIG. 2. This example of E-UTRAN consists of eNBs, providing the E-UTRA user plane (RLC/MAC/PHY) and control plane (RRC) protocol terminations towards the UE. The eNBs are connected by means of the S1 interface to the EPC (evolved packet core), which is made out of Mobility Management Entities (MMEs) and/or gateways such as an access gateway (aGW). The S1 interface supports a many-to-many relation between MMEs and eNBs. Packet Data Convergence Protocol (PDCP) is located in an eNB.

20 In this example there exists an X2 interface between the eNBs that need to communicate with each other. For exceptional cases (e.g. inter-PLMN handover), LTE_ACTIVE inter-eNB mobility is supported by means of MME relocation via the S1 interface.

25 The eNB may host functions such as radio resource management (radio bearer control, radio admission control, connection mobility control, dynamic allocation of resources to UEs in both uplink and downlink), selection of a mobility management entity (MME) at UE attachment, scheduling and transmission of paging messages (originated from the MME), scheduling and transmission of broadcast information (originated from the MME or O&M), and measurement and measurement reporting configuration for mobility and scheduling. The MME may host functions such as the following: distribution of paging messages to the eNBs,

security control, IP header compression and encryption of user data streams; termination of U-plane packets for paging reasons; switching of U-plane for support of UE mobility, idle state mobility control, System Architecture Evolution (SAE) bearer control, and ciphering and integrity protection of NAS signaling.

5 In mobile telecommunications, the two basic types of power control are open-loop and closed-loop. In open-loop power control (OLPC), a mobile terminal measures received pilot signal power and accordingly sets the transmission power density (PDS) according to this measured quantity, and based on the pilot transmitted power, the S(I)NR target, and the interference level (these last values are usually broadcasted by the base station). In closed-
10 loop power control, the measurements are done on the other end of the connection, in the base station, and the results are then sent back to the mobile terminal so that the mobile terminal can adjust its transmission power. Note that the term “base station” is used broadly in this application, and may refer to a Node B, or an eNodeB, or the like.

 The current trend in the art is that uplink power control will include: (i) an open loop
15 power control mechanism at the terminal, as well as (ii) options for the eNode-B to send closed loop power control correction commands to the terminal. The current invention solves problems that occur with uplink power control and associated signalling from the terminal to the base station (eNode-B) to facilitate efficient uplink radio resource management decisions at the eNode-B.

20 Given this uplink power control scheme, the eNode-B may be unaware of the transmit power level at which different terminals are operating. This information is important for the eNode-B, because this knowledge is needed for optimal radio resource management decisions such as allocating MCS (modulation and coding scheme) and transmission bandwidth for the different terminals. It therefore has been discussed in 3GPP that terminals should be able to
25 provide power control headroom reports to the eNode-B. The power control headroom report basically provides a measure of how close the terminal’s power spectral density (PSD) is to the maximum PSD limit. The maximum PSD might be derived from the maximum UE

transmit power (typically assumed to be on the order of 24 dBm) and the minimum bandwidth (typically 1 PRB).

Unfortunately, 3GPP has not yet been able to find satisfactory criteria for sending a power control headroom report from the user terminal to the eNode-B. In LTE uplink (UL), the eNode-B makes the scheduling and radio resource management decisions such as selecting the UEs to transmit, allocating the UE transmission bandwidths, and (as mentioned above) selecting the MCS they should use. These decisions are then signalled to the terminal(s) via dedicated signalling (e.g. UL scheduling grant message). And, in order to make these decisions properly, the eNode-B should be aware of the power level at which the terminals are transmitting, or some equivalent information like the power headroom information, since from this information the eNodeB derives which MCS can be supported in the future with a targeted block error rate (BLER) which would be otherwise not possible. Knowing at the eNode-B the power spectral density used by the mobile terminals is particularly important when selecting the transmission bandwidth (rather than the MCS). Not knowing with precision the PSD used by a mobile terminal when selecting the MCS has only a major impact in case of slow AMC (in which case the PSD is "automatically" increased/decreased when the MCS is modified).

Consequently, reporting of power headroom or some equivalent information is needed. However, reporting of the power control headroom is a trade-off between uplink signalling overhead versus performance improvements that result from having this information readily available at the eNode-B.

It is problematic to have the terminal periodically report the power control headroom at a frequency higher than the adjustments of the actual terminal power spectral density (PSD). Further, the aim of these power adjustments at the terminal is basically to (partly or fully) compensate the path-loss (including antenna-pattern, distance dependent path-loss and shadowing) between the eNode-B and the terminal, and the measurement of path-loss is done based on the DL (e.g. DL pilot channel). Even if the frequency of potential power adjustments at the terminal is high but the measured path-loss is not changing, UL signalling

would be a waste of resources; the only issue then for reporting would be if closed loop power control commands would come from the eNodeB and some of those commands would be misinterpreted at the UE. Then, the problem occurs that the eNodeB does not know the used transmission power. The problem with power control commands being misinterpreted at the mobile terminal is only an issue if relative closed loop power control commands are used (which is also the working assumption in 3GPP).

In HSUPA, the UE Power Headroom (UPH) is part of the Scheduling Information (SI), which is transmitted by the UE as part of the MAC-e header. If the UE is not allocated resources for the transmission of scheduled-data, then Scheduling Information can be transmitted periodically and/or based on specific triggers (i.e. when data arrives in the buffer). Otherwise, only periodic reporting is supported.

Summary of the Invention

Although the present invention is applicable in the context of the E-UTRAN (LTE or 3.9G), its principles are not limited to such an environment, and instead may also be applicable to various other current and future wireless telecommunications systems and access technologies. This invention provides specific reporting criteria that are an attractive trade-off between signalling overhead versus overall uplink performance for LTE. The following triggering criteria are found to be very efficient for sending a power control headroom report in the uplink, while optimizing uplink performance, and while minimizing signalling overhead.

The first triggering criterion is that, once “n” closed loop power corrections have been received by a terminal (sent from the eNode-B), the power control headroom is measured by the terminal over the next “m” transmission time intervals (TTIs) and afterwards reported to the eNode-B. The reason for this first criterion is, as already mentioned above, that the closed loop commands can be misinterpreted at the terminal and therefore tracking of power status at the eNodeB would lead to the accumulation of such errors. The problem with power control commands being misinterpreted at the mobile terminal is only an issue if relative closed loop

power control commands are used (which is also the working assumption in 3GPP).

The second triggering criterion is that, after the terminal's open loop power control algorithm modifies the PSD, the terminal shall measure the power control headroom over the following "m" TTIs and afterwards report it to the eNode-B.

5 The third triggering criterion is that, in order to further limit the signalling of uplink power control headroom reports, the terminal shall only send a new power control headroom report if the time since the last reporting exceeds "k" TTIs.

And, the fourth triggering criterion is that, instead of the third triggering criterion, another embodiment of the invention is that the terminal shall only send a new power control
10 headroom report if the absolute difference between the current and the latest path-loss measurement is higher than a given threshold "p".

The three aforementioned quantities "n", "m", "k" (or "p" if the fourth rather than third triggering criterion is used) are parameters that are configured by the eNode-B. As an example, these parameters can be configured via RRC signalling from the eNode-B to the
15 terminal. These described triggering criteria can be combined (e.g. using a logical "OR" combination).

Brief Description of the Drawings

Figure 1 shows a UTRAN network.

20 Figure 2 shows an LTE architecture.

Figure 3 is a flow chart showing an embodiment of a method according to the present invention.

Figure 4 is a block diagram of a system according to an embodiment of the present invention.

Detailed Description of the Invention

25 A preferred embodiment of the present invention will now be described. This is merely to illustrate one way of implementing the invention, without limiting the scope or coverage of what is described elsewhere in this application.

In this preferred embodiment, the reporting criteria are implemented in the terminal. However, the protocol for signalling the parameters “n”, “m”, “k” and/or “p” requires implementation at both the eNode-B and the terminal. This embodiment of the invention provides an attractive trade-off between signalling overhead and performance.

5 As seen in FIG. 3, the method 300 can begin with the base station adjusting 307 one or more of the thresholds “n”, “m”, “k” and/or “p” at the user equipment (UE) by signalling to the UE. At some subsequent point in time, the UE determines 315 that a triggering criterion has been met because one of those thresholds have been reached (or some combination of those thresholds have been reached). This will trigger the UE to provide 325
10 a power control headroom report on the uplink. When this report is received 335 at the base station, the base station will then use that report to help provide 370 a closed loop power control correction command to the user equipment.

Referring now to FIG. 4, a system 400 is shown according to an embodiment of the invention, including a network element 492 and a user equipment 405. At the network
15 element, a threshold adjustment module 468 instructs transceiver 454 to send a threshold adjustment signal to the user equipment. At some subsequent point, a triggering module 413 at the user equipment determines that the threshold has been reached, and therefore instructs transceiver 411 to provide a power control headroom report to the network element, which processes the report in a report receiving module 463. The report receiving module 463 will
20 thereby help the network element to provide a closed loop power control correction command to the user equipment 405.

Each of the embodiments described above can be implemented using a general purpose or specific-use computer system, with standard operating system software conforming to the method described herein. The software is designed to drive the operation
25 of the particular hardware of the system, and will be compatible with other system components and I/O controllers. The computer system of this embodiment includes a CPU processor, comprising a single processing unit, multiple processing units capable of parallel operation, or the CPU can be distributed across one or more processing units in one or more

locations, e.g., on a client and server. A memory may comprise any known type of data storage and/or transmission media, including magnetic media, optical media, random access memory (RAM), read-only memory (ROM), a data cache, a data object, etc. Moreover, similar to the CPU, the memory may reside at a single physical location, comprising one or more types of data storage, or be distributed across a plurality of physical systems in various forms.

It is to be understood that the present figures, and the accompanying narrative discussions of best mode embodiments, do not purport to be completely rigorous treatments of the method, system, mobile device, network element, and software product under consideration. A person skilled in the art will understand that the steps and signals of the present application represent general cause-and-effect relationships that do not exclude intermediate interactions of various types, and will further understand that the various steps and structures described in this application can be implemented by a variety of different sequences and configurations, using various different combinations of hardware and software which need not be further detailed herein.

The invention includes a variety of concepts, which can be briefly described as follows, without in any way limiting what will be claimed in the future in reliance upon this provisional application. It is to be understood that the following concepts can be further combined with each other in any multiple dependent manner, without departing from the scope of the invention.

Claims

1. A method (300) comprising:
determining (315) that a set of at least one triggering criterion is met; and
providing (325) a power control headroom report on an uplink from user equipment,
5 in response to determining that the set is met,
wherein said at least one triggering criterion include a threshold having been reached.
2. The method of claim 1, wherein said threshold is adjustable via a signal to the
user equipment.
10
3. The method of claim 1, wherein the set comprises a criterion such that an
absolute difference between current and most recent path-loss measurements has reached a
threshold of difference.
4. The method of claim 1, wherein said set of at least one triggering criterion include
15 any one of a plurality of criteria that each entail reaching a respective threshold.
5. The method of claim 4, wherein the plurality of criteria comprise a first criterion,
a second criterion, and a third criterion.
20
6. The method of claim 1, wherein the set comprises a criterion such that a number
of received closed loop power corrections has reached a threshold of corrections.
7. The method of claim 1, wherein the set comprises a criterion such that an amount
25 of transmission time intervals, following an open loop power control modification, has
reached a threshold of intervals since modification.
8. The method of claim 1, wherein the set comprises a criterion such that an amount

of transmission time intervals, following a previous power control headroom report, has reached a threshold of intervals since reporting.

9. The method of claim 5,

5 wherein the first criterion is such that a number of received closed loop power corrections has reached a threshold of corrections, and

wherein the second criterion is such that an amount of transmission time intervals, following an open loop power control modification, has reached a threshold of intervals since modification.

10

10. The method of claim 9, wherein the third criterion is such that an amount of transmission time intervals, following a previous power control headroom report, has reached a threshold of intervals since reporting.

15

11. The method of claim 9, wherein the third criterion is such that an absolute difference between current and most recent path-loss measurements has reached a threshold of difference.

12. An apparatus (405) comprising:

20

means (413) for determining that a set of at least one triggering criterion is met; and means (411) for providing a power control headroom report on an uplink from user equipment, in response to the set having been met,

wherein said at least one triggering criterion include a threshold having been reached.

25

13. The apparatus of claim 12, wherein said threshold is adjustable via a signal to the user equipment.

14. The apparatus of claim 12, wherein the set comprises a criterion such that an

absolute difference between current and most recent path-loss measurements has reached a threshold of difference.

5 15. The apparatus of claim 12, wherein said set of at least one triggering criterion include any one of a plurality of criteria that each entail reaching a respective threshold.

10 16. The apparatus of claim 15, wherein the plurality of criteria comprise a first criterion, a second criterion, and a third criterion.

17. The apparatus of claim 16,
wherein the first criterion is such that a number of received closed loop power corrections has reached a threshold of corrections, and
wherein the second criterion is such that an amount of transmission time intervals,
15 following an open loop power control modification, has reached a threshold of intervals since modification.

18. The apparatus of claim 17, wherein the third criterion is such that an amount of
transmission time intervals, following a previous power control headroom report,
20 has reached a threshold of intervals since reporting.

19. The apparatus of claim 17, wherein the third criterion is such that an absolute
difference between current and most recent path-loss measurements has reached a
threshold of difference.

25 20. Apparatus (405) comprising:
a triggering module (413) configured to determine that a set of at least one triggering
criterion is met; and

a transceiver (411) configured to provide a power control headroom report on an uplink from said user equipment, in response to the set having been met,
wherein said at least one triggering criterion include a threshold having been reached.

5 21. The apparatus of claim 20, wherein said threshold is adjustable via a signal to the apparatus.

 22. The apparatus of claim 20, wherein the set comprises a criterion such that an absolute difference between current and most recent path-loss measurements has reached a
10 threshold of difference.

 23. The apparatus of claim 20, wherein said set of at least one triggering criterion include any one of a plurality of criteria that each entail reaching a respective threshold.

15 24. The apparatus of claim 23, wherein the plurality of criteria comprise a first criterion, a second criterion, and a third criterion.

 25. The apparatus of claim 24,
 wherein the first criterion is such that a number of received closed loop power
20 corrections has reached a threshold of corrections, and

 wherein the second criterion is such that an amount of transmission time intervals, following an open loop power control modification, has reached a threshold of intervals since modification.

25 26. The apparatus of claim 24, wherein the third criterion is such that an amount of transmission time intervals, following a previous power control headroom report, has reached a threshold of intervals since reporting.

27. The apparatus of claim 24, wherein the third criterion is such that an absolute difference between current and most recent path-loss measurements has reached a threshold of difference.

5 28. A computer program product comprising a computer readable medium having executable code stored therein; the code, when executed by a processor, adapted to carry out the functions of:

 determining (315) that a set of at least one triggering criterion is met; and
 providing (325) a power control headroom report on an uplink from user equipment,
10 in response to the set having been met,
 wherein said at least one triggering criterion include a threshold having been reached.

 29. The computer program product of claim 28, wherein said threshold is adjustable via a signal to the user equipment.

15

 30. The computer program product of claim 28, wherein the set comprises a criterion such that an absolute difference between current and most recent path-loss measurements has reached a threshold of difference.

20 31. The computer program product of claim 28, wherein said set of at least one triggering criterion include any one of a plurality of criteria that each entail reaching a respective threshold.

 32. The computer program product of claim 31, wherein the plurality of criteria
25 comprise a first criterion, a second criterion, and a third criterion.

 33. The computer program product of claim 32,
 wherein the first criterion is such that a number of received closed loop power

corrections has reached a threshold of corrections, and

wherein the second criterion is such that an amount of transmission time intervals, following an open loop power control modification, has reached a threshold of intervals since modification.

5

34. A network element (492) comprising:

a report receiving module (463) configured to receive a power control headroom report on an uplink from user equipment, in response to the user equipment determining that a set of at least one triggering criterion is met because a threshold has been reached, and

10 a threshold adjustment module (468) , configured to provide a threshold adjustment signal to the user equipment in order to adjust the threshold.

35. The network element of claim 34, wherein the set comprises a criterion such that an absolute difference between current and most recent path-loss measurements has reached a
15 threshold of difference.

36. The network element of claim 34, further comprising a correction module configured to provide a closed loop power control correction command signal to the user equipment at least partly in response to said power control headroom report.

20

37. A system (400) comprising:

user equipment (405) having a triggering module (413) configured to determine that a set of at least one triggering criterion is met, and having a transceiver (411) configured to provide a power control headroom report on an uplink from said user equipment, in response
25 to the set having been met, wherein said at least one triggering criterion include a threshold having been reached; and

a network element (492) having a report receiving module (463) configured to receive a power control headroom report on an uplink from user equipment, in response to the user

equipment determining that a set of at least one triggering criterion is met because said threshold has been reached, and having a threshold adjustment module (468) configured to provide a threshold adjustment signal to the user equipment in order to adjust the threshold.

5 38. The system of claim 37, wherein the set comprises a criterion such that an absolute difference between current and most recent path-loss measurements has reached a threshold of difference.

 39. The system of claim 37,
10 wherein the set comprises a first criterion, a second criterion, and a third criterion,
 wherein the first criterion is such that a number of received closed loop power corrections has reached a threshold of corrections, and
 wherein the second criterion is such that an amount of transmission time intervals, following an open loop power control modification, has reached a threshold of intervals since
15 modification.

FIG. 1

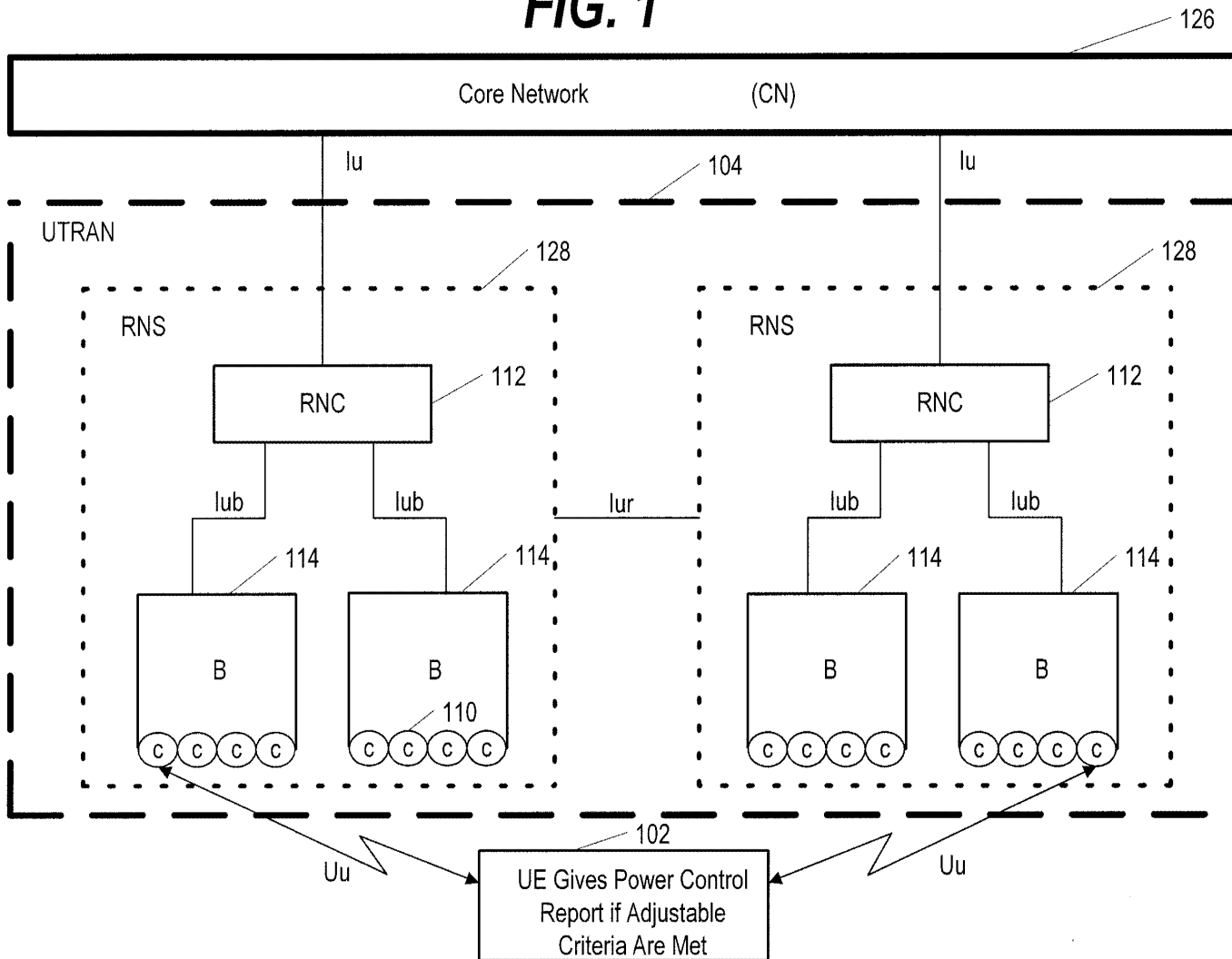

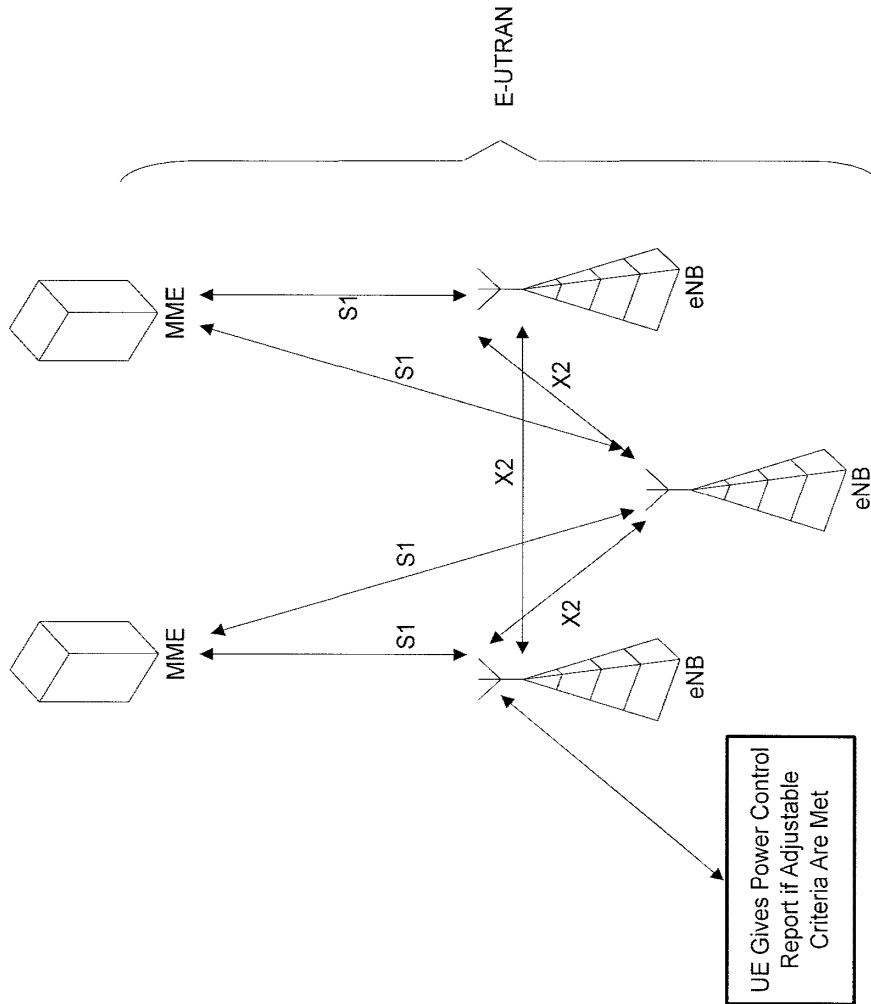

FIG. 2

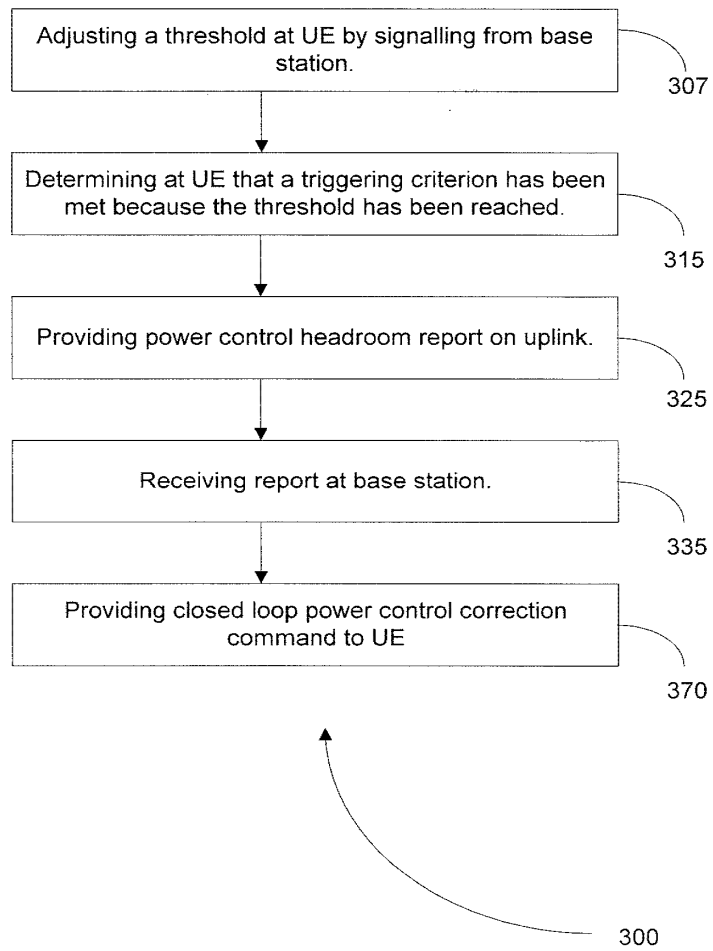

FIG. 3

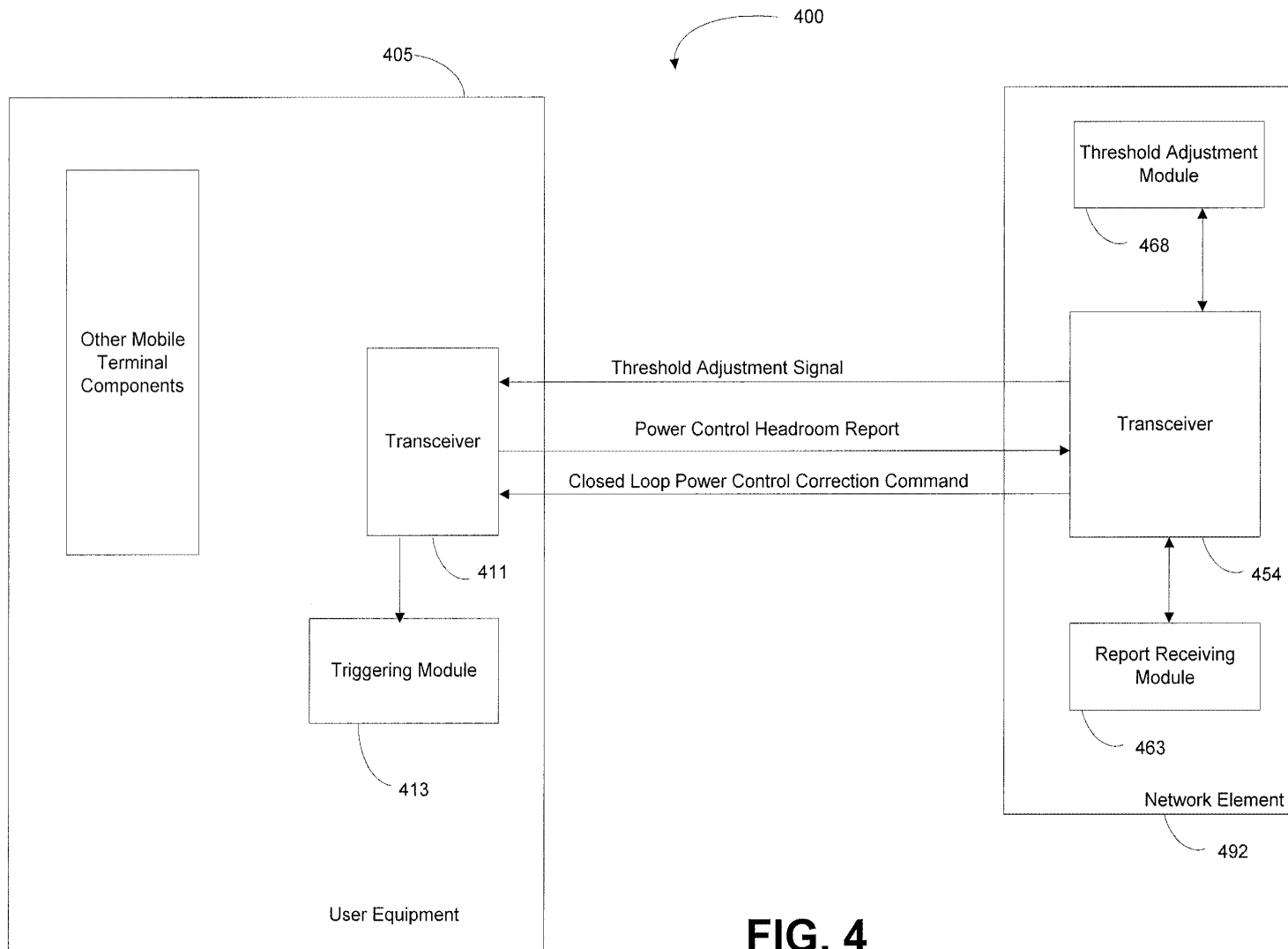

FIG. 4

Document made available under the Patent Cooperation Treaty (PCT)

International application number: PCT/FI2008/050384

International filing date: 23 June 2008 (23.06.2008)

Document type: Certified copy of priority document

Document details: Country/Office: US
Number: 60/936,649
Filing date: 20 June 2007 (20.06.2007)

Date of receipt at the International Bureau: 18 August 2008 (18.08.2008)

Remark: Priority document submitted or transmitted to the International Bureau in compliance with Rule 17.1(a) or (b)



World Intellectual Property Organization (WIPO) - Geneva, Switzerland
Organisation Mondiale de la Propriété Intellectuelle (OMPI) - Genève, Suisse

PA 1708892

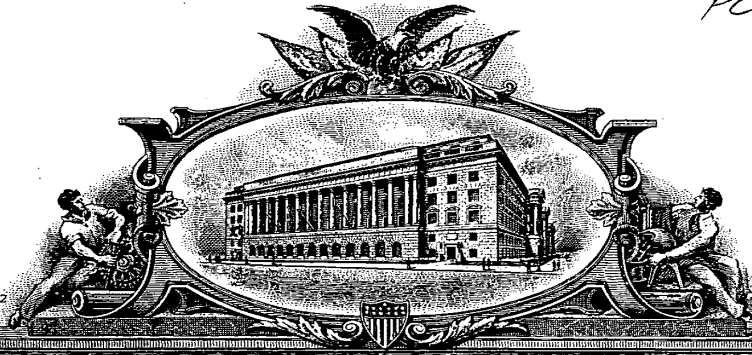

THE UNITED STATES OF AMERICA

TO ALL TO WHOM THESE PRESENTS SHALL COME:

UNITED STATES DEPARTMENT OF COMMERCE

United States Patent and Trademark Office

July 14, 2008

THIS IS TO CERTIFY THAT ANNEXED HERETO IS A TRUE COPY FROM THE RECORDS OF THE UNITED STATES PATENT AND TRADEMARK OFFICE OF THOSE PAPERS OF THE BELOW IDENTIFIED PATENT APPLICATION THAT MET THE REQUIREMENTS TO BE GRANTED A FILING DATE UNDER 35 USC 111.

APPLICATION NUMBER: 60/936,649

FILING DATE: June 20, 2007

THE COUNTRY CODE AND NUMBER OF YOUR PRIORITY APPLICATION, TO BE USED FOR FILING ABROAD UNDER THE PARIS CONVENTION, IS US60/936,649

**By Authority of the
Under Secretary of Commerce for Intellectual Property
and Director of the United States Patent and Trademark Office**

L. Edelen

**L. EDELEN
Certifying Officer**



U.S. PTO
60/936649
06/20/2007
PATENT

Practitioner's Docket No. 944-021.005

Preliminary Classification:

Proposed Class:

Subclass:

NOTE: "All applicants are requested to include a preliminary classification on newly filed patent applications. The preliminary classification, preferably class and subclass designations, should be identified in the upper right-hand corner of the letter of transmittal accompanying the application papers, for example 'Proposed Class 2, subclass 129.'" M.P.E.P., § 601, 7th ed.

IN THE UNITED STATES PATENT AND TRADEMARK OFFICE

In re application of: Jürgen MICHEL, Klaus I. PEDERSEN, Cláudio ROSA

For: Power Headroom Reporting Method

Mail Stop Provisional Patent Application

Commissioner for Patents

P.O. Box 1450, Alexandria, VA 22313-1450

COVER SHEET FOR FILING PROVISIONAL APPLICATION

(37 C.F.R. § 1.51(c)(1))

WARNING: "A provisional application must also include the cover sheet required by § 1.51(c)(1) or a cover letter identifying the application as a provisional application. Otherwise, the application will be treated as an application filed under paragraph (b) [nonprovisional application] of this section." 37 C.F.R. § 1.53(c)(1). See also M.P.E.P. § 201.04(b), 6th ed., rev. 3.

EXPRESS MAILING UNDER 37 C.F.R. § 1.10*

(Express Mail label number is mandatory.)

(Express Mail certification is optional.)

I hereby certify that this paper, along with any document referred to, is being deposited with the United States Postal Service on this date June 20, 2007, in an envelope addressed to the Commissioner for Patents, P.O. Box 1450, Alexandria, VA 22313-1450 as "Express Mail Post Office to Addressee" Mailing Label No. EV 913599106 US

Margery B. Hood

(type or print name of person mailing paper)

Margery B. Hood

Signature of person certifying

WARNING: Certificate of mailing (first class) or facsimile transmission procedures of 37 C.F.R. 1.8 cannot be used to obtain a date of mailing or transmission for this correspondence.

***WARNING:** Each paper or fee filed by "Express Mail" must have the number of the "Express Mail" mailing label placed thereon prior to mailing. 37 C.F.R. 1.10(b).

"Since the filing of correspondence under § 1.10 without the Express Mail mailing label thereon is an oversight that can be avoided by the exercise of reasonable care, requests for waiver of this requirement will not be granted on petition." Notice of Oct. 24, 1996, 60 Fed. Reg. 56,439, at 56,442.

(Cover Sheet for Filing Provisional Application [23-1]—page 1 of 5)

16138 U.S. PTO

- NOTE:** "A complete provisional application does not require claims since no examination on the merits will be given to a provisional application. However, provisional applications may be filed with one or more claims as part of the application. Nevertheless, no additional claim fee or multiple dependent claims fee will be required in a provisional application." Notice of December 5, 1994, 59 Fed. Reg. 63,951, at 63,953.
 "Any claim filed with a provisional application will, of course, be considered part of the original provisional application disclosure." Notice of April 14, 1995, 60 Fed. Reg. 20,195, at 20,209.
- NOTE:** "A provisional application is not entitled to the right of priority under 35 U.S.C. 119 or 365(a) or § 1.55, or to the benefit of an earlier filing date under 35 U.S.C. 120, 121 or 365(c) or § 1.78 of any other application. No claim for priority under § 1.78(a)(3) may be made in a design application based on a provisional application. No request under § 1.293 for a statutory invention registration may be filed in a provisional application. The requirements of §§ 1.821 through 1.825 regarding application disclosures containing nucleotide and/or amino acid sequences are not mandatory for provisional applications." 37 C.F.R. § 1.53(c)(3).
- NOTE:** "No information disclosure statement may be filed in a provisional application." 37 C.F.R. § 1.51(d).
 "Any information disclosure statements filed in a provisional application would either be returned or disposed of at the convenience of the Office." Notice of December 5, 1994, 59 Fed. Reg. 63,591, at 63,594.
- NOTE:** "No amendment other than to make the provisional application comply with the patent statute and all applicable regulations may be made to the provisional application after the filing date of the provisional application." 37 C.F.R. § 1.53(c).
- NOTE:** 35 U.S.C. 119(e)(1) requires that a nonprovisional application be filed within twelve months of the filing date of the provisional application for the nonprovisional application to claim the benefit of the filing date of the provisional application. Under 35 U.S.C. 21(b) and 119(e)(3), if this twelve-month period expires on a non-business day, it is extended to expire on the next business day.

This is a request for filing a PROVISIONAL APPLICATION FOR PATENT under 37 C.F.R. § 1.51(c)(1)(i).

1. The following comprises the information required by 37 C.F.R. § 1.51(c)(1):
2. The name(s) of the inventor(s) is/are (37 C.F.R. § 1.51(c)(1)(ii)):

NOTE: "If the correct inventor or inventors are not named on filing a provisional application without a cover sheet under § 1.15(c)(1), the later submission of a cover sheet under § 1.15(c)(1) during the pendency of the application will act to correct the earlier identification of inventorship." 37 C.F.R. § 1.48(f)(2).

NOTE: "The naming of inventors for obtaining a filing date for a provisional application is the same as for other applications. A provisional application filed with the inventors identified as 'Jones et al.' will not be accorded a filing date earlier than the date upon which the name of each inventor is supplied unless a petition with the fee set forth in § 1.17(i) is filed which sets forth the reasons the delay in supplying the names should be excused. Administrative oversight is an acceptable reason. It should be noted that for a 35 U.S.C. 111(a) application to be entitled to claim the benefit of the filing date of a provisional application the 35 U.S.C. 111(a) application must have at least one inventor in common with the provisional application." Notice of April 14, 1995, 60 Fed. Reg. 20,195, at 20,209.

The term "invention" is typically used to refer to subject matter which applicant is claiming in his/her application. Because claims are not required in a provisional application, it would not be appropriate to reference joint inventors as those who have made a contribution to the "invention" disclosed in the provisional application. If the "invention" has not been determined in the provisional application because no claims have been presented, then the name(s) of those person(s) who have made a contribution to the subject matter disclosed in the provisional application should be submitted. Section 1.45(c) states that "If multiple inventors are named in a provisional application, each named inventor must have made a contribution, individually or jointly, to the subject matter disclosed in the provisional application." All that § 1.45(c) requires is that if someone is named as an inventor, that person must have made a contribution to the subject matter disclosed in the provisional application. When applicant has determined what the invention is by the filing of the 35 U.S.C. 111(a) application, that is the time when the correct inventors must be named. The 35 U.S.C. 111(a) application must have an inventor in common with the provisional application in order for the 35 U.S.C. 111(a) application to be entitled to claim the benefit of the provisional application under 35 U.S.C. 119(e). Notice of April 14, 1995, 60 Fed. Reg. 20,195, at 20,208.

See 37 C.F.R. § 1.53.

(Cover Sheet for Filing Provisional Application [23-1]—page 2 of 6)

1.	<u>Jürgen</u>	<u></u>	<u>MICHEL</u>
	GIVEN NAME	MIDDLE INITIAL OR NAME	FAMILY (OR LAST) NAME
2.	<u>Klaus</u>	<u>I.</u>	<u>PEDERSEN</u>
	GIVEN NAME	MIDDLE INITIAL OR NAME	FAMILY (OR LAST) NAME
3.	<u>Claudio</u>	<u></u>	<u>ROSA</u>
	GIVEN NAME	MIDDLE INITIAL OR NAME	FAMILY (OR LAST) NAME

3. Residence address(es) of the inventor(s), as numbered above (37 C.F.R. § 1.51(c)(1)(iii)):

1. Sebastian-Bauer-Strasse 35, 81737 München, Germany
2. Laesogade 9, 3th, 9000 Aalborg, Denmark
3. Krebsen 14, 8900 Randers, Denmark

4. The title of the invention is (37 C.F.R. § 1.51(c)(1)(iv)):

Power Headroom Reporting Method

5. The name, registration, customer and telephone numbers of the practitioner (if applicable) is (37 C.F.R. § 1.51(c)(1)(v)):

Name of practitioner: Andrew T. Hyman

Reg. No. 45,858 Tel. (203) 261-1234

Customer No. 004955

(complete the following, if applicable)

A power of attorney accompanies this cover sheet.

6. The docket number used to identify this application is (37 C.F.R. § 1.51(c)(1)(vi)):

Docket No.: 944-021.005

7. The correspondence address for this application is (37 C.F.R. § 1.51(c)(1)(vii)):

WARE, FRESSOLA, VAN DER SLUYS & ADOLPHSON LLP

755 Main Street, PO Box 224, Monroe CT 06468

8. Statement as to whether invention was made by an agency of the U.S. Government or under contract with an agency of the U.S. Government.
(37 C.F.R. § 1.51(c)(1)(viii))

This invention was made by an agency of the United States Government, or under contract with an agency of the United States Government.

No.

Yes.

The name of the U.S. Government agency and the Government contract number are: _____

(Cover Sheet for Filing Provisional Application [23-1]—page 3 of 5)

9. Identification of documents accompanying this cover sheet:

A. Documents required by 37 C.F.R. §§ 1.51(c)(2)-(3):

Specification:

No. of pages 16

Drawings:

No. of sheets 4

B. Additional documents:

Claims:

No. of claims _____

Note: See 37 C.F.R. § 1.51.

Power of attorney

Small entity assertion

Assignment

English language translation of non-English provisional application

NOTE: A provisional application which is filed in a language other than English, does not have to have an English language translation. See 37 C.F.R. § 1.52(d)(2). However, if the provisional application is not in the English language and will later serve as a benefit of its filing date for a nonprovisional application, other than a design patent, or for an international application designating the U.S., then an English language translation must be filed in the provisional application or the later filed nonprovisional application. See § 1.78(a)(5)(iv).

This application is in a language other than English and an English translation along with a statement of its accuracy is submitted herewith.

Other

10. Fee

The filing fee for this provisional application, as set in 37 C.F.R. § 1.16(k), is \$160.00, for other than a small entity, and \$80.00, for a small entity.

Applicant is a small entity.

NOTE: "A . . . statement in compliance with existing § 1.27 is required to be filed in each provisional application in which it is desired to pay reduced fees." Notice of April 14, 1995, 60 Fed. Reg. 20,195, at 20,197.

11. Small entity assertion

The assertion that this is a filing by a small entity under 37 C.F.R. § 1.27(c)(1) is attached. ("ASSERTION OF SMALL ENTITY STATUS")

Small entity status is asserted for this application by payment of the small entity filing fee under § 1.16(k). 37 C.F.R. § 1.27(c)(3).

12. Fee payment

Fee payment in the amount of \$ 200⁰⁰ is being made at this time.

No filing fee is to be paid at this time. (This and the surcharge required by 37 C.F.R. 1.16(l) can be paid subsequently).

(Cover Sheet For Filing Provisional Application [23-1]—page 4 of 5)

13. Method of fee payment

- Attached is a check money order in the amount of \$ 200.00
 Authorization is hereby made to charge the amount of any deficiency
 to Deposit Account No. 23-0442
 to Credit card as shown on the attached credit card information authorization form PTO-2038.

WARNING: Credit card information should not be included on this form as it may become public.

- Charge any additional fees required by this paper or credit any overpayment in the manner authorized above.

A duplicate of this paper is attached.

Date: _____

Tel.: ()

Date: 6/20/07

Reg. No.: 45,858

Tel.: (203) 261-1234

Customer No.: 004955

Signature of submitter

OR

Andrew T. Hyman
Signature of practitioner

Andrew T. Hyman
(type or print name of practitioner)

WARE, FRESSOLA, VAN DER SLUYS
P.O. Address & ADOLPHSON LLP

755 Main Street, PO Box 224
Monroe CT 06468

(Cover Sheet For Filing Provisional Application [23-1]—page 5 of 5)

944-021.005

U.S. Provisional Patent Application of

**Jürgen MICHEL,
Klaus I. PEDERSEN
and
Claudio ROSA**

relating to a

POWER HEADROOM REPORTING METHOD

Exp. Mail No. EV 913599106 US

POWER HEADROOM REPORTING METHOD

5 **Field of the Invention**

The invention relates to the field of wireless telecommunications. More particularly, the present invention pertains to power control.

Background of the Invention

10 The telecommunications industry is in the process of developing a new generation of flexible and affordable communications that includes high-speed access while also supporting broadband services. Many features of the third generation (3G) mobile telecommunications system have already been established, but many other features have yet to be perfected. The Third Generation Partnership Project (3GPP) has been pivotal in these developments.

15 One of the systems within the third generation of mobile communications is the Universal Mobile Telecommunications System (UMTS) which delivers voice, data, multimedia, and wideband information to stationary as well as mobile customers. UMTS is designed to accommodate increased system capacity and data capability. Efficient use of the electromagnetic spectrum is vital in UMTS. It is known that spectrum efficiency can be
20 attained using frequency division duplex (FDD) or using time division duplex (TDD) schemes. Space division duplex (SDD) is a third duplex transmission method used for wireless telecommunications.

As can be seen in FIG. 1, the UMTS architecture consists of user equipment 102 (UE), the UMTS Terrestrial Radio Access Network 104 (UTRAN), and the Core Network
25 126 (CN). The air interface between the UTRAN and the UE is called Uu, and the interface between the UTRAN and the Core Network is called Iu.

High-Speed Downlink Packet Access (HSDPA) and High-Speed Uplink Packet Access (HSUPA) are further 3G mobile telephony protocols in the High-Speed Packet Access

(HSPA) family. They provide a smooth evolutionary path for UMTS-based networks allowing for higher data transfer speeds.

Evolved UTRAN (EUTRAN) is a more recent project than HSPA, and is meant to take 3G even farther into the future. EUTRAN is designed to improve the UMTS mobile phone standard in order to cope with various anticipated requirements. EUTRAN is frequently indicated by the term Long Term Evolution (LTE), and is also associated with terms like System Architecture Evolution (SAE). One target of EUTRAN is to enable all internet protocol (IP) systems to efficiently transmit IP data. The system will have only use a PS (packet switched) domain for voice and data calls, i.e. the system will contain Voice Over Internet Protocol (VoIP).

Information about LTE can be found in 3GPP TS 36.300 (V8.0.0, March 2007), *Evolved Universal Terrestrial Radio Access (E-UTRA) and Evolved Universal Terrestrial Radio Access Network (E-UTRAN) – Overall description; Stage 2 (Release 8)*, which is incorporated herein by reference in its entirety. UTRAN and EUTRAN will now be described in some further detail, although it is to be understood that especially E-UTRAN is evolving over time.

The UTRAN consists of a set of Radio Network Subsystems 128 (RNS), each of which has geographic coverage of a number of cells 110 (C), as can be seen in FIG. 1. The interface between the subsystems is called Iur. Each Radio Network Subsystem 128 (RNS) includes a Radio Network Controller 112 (RNC) and at least one Node B 114, each Node B having geographic coverage of at least one cell 110. As can be seen from Figure 1, the interface between an RNC 112 and a Node B 114 is called Iub, and the Iub is hard-wired rather than being an air interface. For any Node B 114 there is only one RNC 112. A Node B 114 is responsible for radio transmission and reception to and from the UE 102 (Node B antennas can typically be seen atop towers or preferably at less visible locations). The RNC 112 has overall control of the logical resources of each Node B 114 within the RNS 128, and the RNC 112 is also responsible for handover decisions which entail switching a call from one cell to another or between radio channels in the same cell.

In UMTS radio networks, a UE can support multiple applications of different qualities of service running simultaneously. In the MAC layer, multiple logical channels can be multiplexed to a single transport channel. The transport channel can define how traffic from logical channels is processed and sent to the physical layer. The basic data unit exchanged
5 between MAC and physical layer is called the Transport Block (TB). It is composed of an RLC PDU and a MAC header. During a period of time called the transmission time interval (TTI), several transport blocks and some other parameters are delivered to the physical layer.

Generally speaking, a prefix of the letter "E" in upper or lower case signifies the Long Term Evolution (LTE). The E-UTRAN consists of eNBs (E-UTRAN Node B), providing the
10 E-UTRA user plane (RLC/MAC/PHY) and control plane (RRC) protocol terminations towards the UE. The eNBs interface to the access gateway (aGW) via the S1, and are interconnected via the X2.

An example of the E-UTRAN architecture is illustrated in FIG. 2. This example of E-UTRAN consists of eNBs, providing the E-UTRA user plane (RLC/MAC/PHY) and
15 control plane (RRC) protocol terminations towards the UE. The eNBs are connected by means of the S1 interface to the EPC (evolved packet core), which is made out of Mobility Management Entities (MMEs) and/or gateways such as an access gateway (aGW). The S1 interface supports a many-to-many relation between MMEs and eNBs. Packet Data Convergence Protocol (PDCP) is located in an eNB.

In this example there exists an X2 interface between the eNBs that need to
20 communicate with each other. For exceptional cases (e.g. inter-PLMN handover), LTE_ACTIVE inter-eNB mobility is supported by means of MME relocation via the S1 interface.

The eNB may host functions such as radio resource management (radio bearer control,
25 radio admission control, connection mobility control, dynamic allocation of resources to UEs in both uplink and downlink), selection of a mobility management entity (MME) at UE attachment, scheduling and transmission of paging messages (originated from the MME), scheduling and transmission of broadcast information (originated from the MME or O&M),

and measurement and measurement reporting configuration for mobility and scheduling. The MME may host functions such as the following: distribution of paging messages to the eNBs, security control, IP header compression and encryption of user data streams; termination of U-plane packets for paging reasons; switching of U-plane for support of UE mobility, idle state mobility control, System Architecture Evolution (SAE) bearer control, and ciphering and integrity protection of NAS signaling.

In mobile telecommunications, the two basic types of power control are open-loop and closed-loop. In open-loop power control (OLPC), a mobile terminal measures received pilot signal power and accordingly sets the transmission power density (PDS) according to this measured quantity, and based on the pilot transmitted power, the S(I)NR target, and the interference level (these last values are usually broadcasted by the base station). In closed-loop power control, the measurements are done on the other end of the connection, in the base station, and the results are then sent back to the mobile terminal so that the mobile terminal can adjust its transmission power. Note that the term "base station" is used broadly in this application, and may refer to a Node B, or an eNodeB, or the like.

The current trend in the art is that uplink power control will include: (i) an open loop power control mechanism at the terminal, as well as (ii) options for the eNode-B to send closed loop power control correction commands to the terminal. The current invention solves problems that occur with uplink power control and associated signalling from the terminal to the base station (eNode-B) to facilitate efficient uplink radio resource management decisions at the eNode-B.

Given this uplink power control scheme, the eNode-B may be unaware of the transmit power level at which different terminals are operating. This information is important for the eNode-B, because this knowledge is needed for optimal radio resource management decisions such as allocating MCS (modulation and coding scheme) and transmission bandwidth for the different terminals. It therefore has been discussed in 3GPP that terminals should be able to provide power control headroom reports to the eNode-B. The power control headroom report basically provides a measure of how close the terminal's power spectral density (PSD) is to

the maximum PSD limit. The maximum PSD might be derived from the maximum UE transmit power (typically assumed to be on the order of 24 dBm) and the minimum bandwidth (typically 1 PRB).

Unfortunately, 3GPP has not yet been able to find satisfactory criteria for sending a power control headroom report from the user terminal to the eNode-B. In LTE uplink (UL), the eNode-B makes the scheduling and radio resource management decisions such as selecting the UEs to transmit, allocating the UE transmission bandwidths, and (as mentioned above) selecting the MCS they should use. These decisions are then signalled to the terminal(s) via dedicated signalling (e.g. UL scheduling grant message). And, in order to make these decisions properly, the eNode-B should be aware of the power level at which the terminals are transmitting, or some equivalent information like the power headroom information, since from this information the eNodeB derives which MCS can be supported in the future with a targeted block error rate (BLER) which would be otherwise not possible. Knowing at the eNode-B the power spectral density used by the mobile terminals is particularly important when selecting the transmission bandwidth (rather than the MCS). Not knowing with precision the PSD used by a mobile terminal when selecting the MCS has only a major impact in case of slow AMC (in which case the PSD is "automatically" increased/decreased when the MCS is modified).

Consequently, reporting of power headroom or some equivalent information is needed. However, reporting of the power control headroom is a trade-off between uplink signalling overhead versus performance improvements that result from having this information readily available at the eNode-B.

It is problematic to have the terminal periodically report the power control headroom at a frequency higher than the adjustments of the actual terminal power spectral density (PSD). Further, the aim of these power adjustments at the terminal is basically to (partly or fully) compensate the path-loss (including antenna-pattern, distance dependent path-loss and shadowing) between the eNode-B and the terminal, and the measurement of path-loss is done based on the DL (e.g. DL pilot channel). Even if the frequency of potential power

adjustments at the terminal is high but the measured path-loss is not changing, UL signalling would be a waste of resources; the only issue then for reporting would be if closed loop power control commands would come from the eNodeB and some of those commands would be misinterpreted at the UE. Then, the problem occurs that the eNodeB does not know the used transmission power. The problem with power control commands being misinterpreted at the mobile terminal is only an issue if relative closed loop power control commands are used (which is also the working assumption in 3GPP).

In HSUPA, the UE Power Headroom (UPH) is part of the Scheduling Information (SI), which is transmitted by the UE as part of the MAC-e header. If the UE is not allocated resources for the transmission of scheduled-data, then Scheduling Information can be transmitted periodically and/or based on specific triggers (i.e. when data arrives in the buffer). Otherwise, only periodic reporting is supported.

Summary of the Invention

Although the present invention is applicable in the context of the E-UTRAN (LTE or 3.9G), its principles are not limited to such an environment, and instead may also be applicable to various other current and future wireless telecommunications systems and access technologies. This invention provides specific reporting criteria that are an attractive trade-off between signalling overhead versus overall uplink performance for LTE. The following triggering criteria are found to be very efficient for sending a power control headroom report in the uplink, while optimizing uplink performance, and while minimizing signalling overhead.

The first triggering criterion is that, once "n" closed loop power corrections have been received by a terminal (sent from the eNode-B), the power control headroom is measured by the terminal over the next "m" transmission time intervals (TTIs) and afterwards reported to the eNode-B. The reason for this first criterion is, as already mentioned above, that the closed loop commands can be misinterpreted at the terminal and therefore tracking of power status at the eNodeB would lead to the accumulation of such errors. The problem with power control

commands being misinterpreted at the mobile terminal is only an issue if relative closed loop power control commands are used (which is also the working assumption in 3GPP).

The second triggering criterion is that, after the terminal's open loop power control algorithm modifies the PSD, the terminal shall measure the power control headroom over the following "m" TTIs and afterwards report it to the eNode-B.

The third triggering criterion is that, in order to further limit the signalling of uplink power control headroom reports, the terminal shall only send a new power control headroom report if the time since the last reporting exceeds "k" TTIs.

And, the fourth triggering criterion is that, instead of the third triggering criterion, another embodiment of the invention is that the terminal shall only send a new power control headroom report if the absolute difference between the current and the latest path-loss measurement is higher than a given threshold "p".

The three aforementioned quantities "n", "m", "k" (or "p" if the fourth rather than third triggering criterion is used) are parameters that are configured by the eNode-B. As an example, these parameters can be configured via RRC signalling from the eNode-B to the terminal. These described triggering criteria can be combined (e.g. using a logical "OR" combination).

Brief Description of the Drawings

Figure 1 shows a UTRAN network.

Figure 2 shows an LTE architecture.

Figure 3 is a flow chart showing and embodiment of a method according to the present invention.

Figure 4 is a block diagram of a system according to an embodiment of the present invention.

Detailed Description of the Invention

A preferred embodiment of the present invention will now be described. This is merely to illustrate one way of implementing the invention, without limiting the scope or coverage of what is described elsewhere in this application.

In this preferred embodiment, the reporting criteria are implemented in the terminal. However, the protocol for signalling the parameters “n”, “m”, “k” and/or “p” requires implementation at both the eNode-B and the terminal. This embodiment of the invention provides an attractive trade-off between signalling overhead and performance.

As seen in FIG. 3, the method 300 can begin with the base station adjusting 307 one or more of the thresholds “n”, “m”, “k” and/or “p” at the user equipment (UE) by signalling to the UE. At some subsequent point in time, the UE determines 315 that a triggering criterion has been met because one of those thresholds have been reached (or some combination of those thresholds have been reached). This will trigger the UE to provide 325 a power control headroom report on the uplink. When this report is received 335 at the base station, the base station will then use that report to help provide 370 a closed loop power control correction command to the user equipment.

Referring now to FIG. 4, a system 400 is shown according to an embodiment of the invention, including a network element 492 and a user equipment 405. At the network element, a threshold adjustment module 468 instructs transceiver 454 to send a threshold adjustment signal to the user equipment. At some subsequent point, a triggering module 413 at the user equipment determines that the threshold has been reached, and therefore instructs transceiver 411 to provide a power control headroom report to the network element, which processes the report in a report receiving module 463. The report receiving module 463 will thereby help the network element to provide a closed loop power control correction command to the user equipment 405.

Each of the embodiments described above can be implemented using a general purpose or specific-use computer system, with standard operating system software

conforming to the method described herein. The software is designed to drive the operation of the particular hardware of the system, and will be compatible with other system components and I/O controllers. The computer system of this embodiment includes a CPU processor, comprising a single processing unit, multiple processing units capable of parallel operation, or the CPU can be distributed across one or more processing units in one or more locations, e.g., on a client and server. A memory may comprise any known type of data storage and/or transmission media, including magnetic media, optical media, random access memory (RAM), read-only memory (ROM), a data cache, a data object, etc. Moreover, similar to the CPU, the memory may reside at a single physical location, comprising one or more types of data storage, or be distributed across a plurality of physical systems in various forms.

It is to be understood that the present figures, and the accompanying narrative discussions of best mode embodiments, do not purport to be completely rigorous treatments of the method, system, mobile device, network element, and software product under consideration. A person skilled in the art will understand that the steps and signals of the present application represent general cause-and-effect relationships that do not exclude intermediate interactions of various types, and will further understand that the various steps and structures described in this application can be implemented by a variety of different sequences and configurations, using various different combinations of hardware and software which need not be further detailed herein.

The invention includes a variety of concepts, which can be briefly described as follows, without in any way limiting what will be claimed in the future in reliance upon this provisional application. It is to be understood that the following concepts can be further
5 combined with each other in any multiple dependent manner, without departing from the scope of the invention.

1. A method comprising:
determining that a set of at least one triggering criterion is met; and
10 providing a power control headroom report on an uplink from user equipment, in response to determining that the set is met,
wherein said at least one triggering criterion include a threshold having been reached,
and
wherein said threshold is adjustable via a signal to the user equipment.

15 2. The method of claim 1, wherein said set of at least one triggering criterion include any one of a plurality of criteria that each entail reaching a respective threshold.

20 3. The method of claim 2, wherein the plurality of criteria comprise a first criterion, a second criterion, and a third criterion.

4. The method of claim 1, wherein the set comprises a criterion such that a number of received closed loop power corrections has reached a threshold of corrections.

25 5. The method of claim 1, wherein the set comprises a criterion such that an amount of transmission time intervals, following an open loop power control modification, has reached a threshold of intervals since modification.

6. The method of claim 1, wherein the set comprises a criterion such that an amount of transmission time intervals, following a previous power control headroom report, has reached a threshold of intervals since reporting.

5 7. The method of claim 1, wherein the set comprises a criterion such that an absolute difference between current and most recent path-loss measurements has reached a threshold of difference.

8. The method of claim 3,
10 wherein the first criterion is such that a number of received closed loop power corrections has reached a threshold of corrections, and
wherein the second criterion is such that an amount of transmission time intervals, following an open loop power control modification, has reached a threshold of intervals since modification.

15 9. The method of claim 8, wherein the third criterion is such that an amount of transmission time intervals, following a previous power control headroom report, has reached a threshold of intervals since reporting.

20 10. The method of claim 8, wherein the third criterion is such that an absolute difference between current and most recent path-loss measurements has reached a threshold of difference.

25 11. An apparatus comprising:
means for determining that a set of at least one triggering criterion is met; and
means for providing a power control headroom report on an uplink from user equipment, in response to the set having been met,
wherein said at least one triggering criterion include a threshold having been reached,

and

wherein said threshold is adjustable via a signal to the user equipment.

12. The apparatus of claim 11, wherein said set of at least one triggering criterion
5 include any one of a plurality of criteria that each entail reaching a respective threshold.

13. The apparatus of claim 12, wherein the plurality of criteria comprise a first
criterion, a second criterion, and a third criterion.

10 14. The apparatus of claim 13,
wherein the first criterion is such that a number of received closed loop power
corrections has reached a threshold of corrections, and
wherein the second criterion is such that an amount of transmission time intervals,
following an open loop power control modification, has reached a threshold of intervals since
15 modification.

15. The apparatus of claim 14, wherein the third criterion is such that an amount
of transmission time intervals, following a previous power control headroom report, has
reached a threshold of intervals since reporting.

20 16. The apparatus of claim 14, wherein the third criterion is such that an absolute
difference between current and most recent path-loss measurements has reached a threshold
of difference.

25 17. User equipment comprising:
a triggering module configured to determine that a set of at least one triggering
criterion is met; and
a transceiver configured to provide a power control headroom report on an uplink

from said user equipment, in response to the set having been met,
wherein said at least one triggering criterion include a threshold having been reached,
and
wherein said threshold is adjustable via a signal to the user equipment.

5

18. The user equipment of claim 17, wherein said set of at least one triggering
criterion include any one of a plurality of criteria that each entail reaching a respective
threshold.

10

19. The user equipment of claim 18, wherein the plurality of criteria comprise a first
criterion, a second criterion, and a third criterion.

15

20. The user equipment of claim 19,
wherein the first criterion is such that a number of received closed loop power
corrections has reached a threshold of corrections, and
wherein the second criterion is such that an amount of transmission time intervals,
following an open loop power control modification, has reached a threshold of intervals since
modification.

20

21. The user equipment of claim 19, wherein the third criterion is such that an amount
of transmission time intervals, following a previous power control headroom report, has
reached a threshold of intervals since reporting.

25

22. The user equipment of claim 19, wherein the third criterion is such that an
absolute difference between current and most recent path-loss measurements has reached a
threshold of difference.

23. A computer program product comprising a computer readable medium having

executable code stored therein; the code, when executed by a processor, adapted to carry out the functions of:

determining that a set of at least one triggering criterion is met; and

providing a power control headroom report on an uplink from user equipment, in

5 response to the set having been met,

wherein said at least one triggering criterion include a threshold having been reached,

and

wherein said threshold is adjustable via a signal to the user equipment.

10 24. The computer program product of claim 23, wherein said set of at least one triggering criterion include any one of a plurality of criteria that each entail reaching a respective threshold.

15 25. The computer program product of claim 24, wherein the plurality of criteria comprise a first criterion, a second criterion, and a third criterion.

26. The computer program product of claim 25,

wherein the first criterion is such that a number of received closed loop power corrections has reached a threshold of corrections, and

20 wherein the second criterion is such that an amount of transmission time intervals, following an open loop power control modification, has reached a threshold of intervals since modification.

27. A network element comprising:

25 a report receiving module configured to receive a power control headroom report on an uplink from user equipment, in response to the user equipment determining that a set of at least one triggering criterion is met because a threshold has been reached, and

a threshold adjustment module, configured to provide a threshold adjustment signal to

the user equipment in order to adjust the threshold.

28. The network element of claim 27, further comprising a correction module configured to provide a closed loop power control correction command signal to the user equipment at least partly in response to said power control headroom report.

29. A system comprising:
user equipment having a triggering module configured to determine that a set of at least one triggering criterion is met, and having a transceiver configured to provide a power control headroom report on an uplink from said user equipment, in response to the set having been met, wherein said at least one triggering criterion include a threshold having been reached; and

a network element having a report receiving module configured to receive a power control headroom report on an uplink from user equipment, in response to the user equipment determining that a set of at least one triggering criterion is met because said threshold has been reached, and having a threshold adjustment module configured to provide a threshold adjustment signal to the user equipment in order to adjust the threshold.

30. The system of claim 29,
wherein the set comprises a first criterion, a second criterion, and a third criterion, wherein the first criterion is such that a number of received closed loop power corrections has reached a threshold of corrections, and
wherein the second criterion is such that an amount of transmission time intervals, following an open loop power control modification, has reached a threshold of intervals since modification.

Abstract

A method, user equipment, network device, and software product enable a user equipment to determine that at least one of several triggering criterion have been met, in which case the user equipment provides a power control headroom report on an uplink from the user equipment. The triggering criterion includes a threshold having been reached, and the threshold is adjustable via a signal to the user equipment from a base station (such as an eNodeB).

FIG. 1

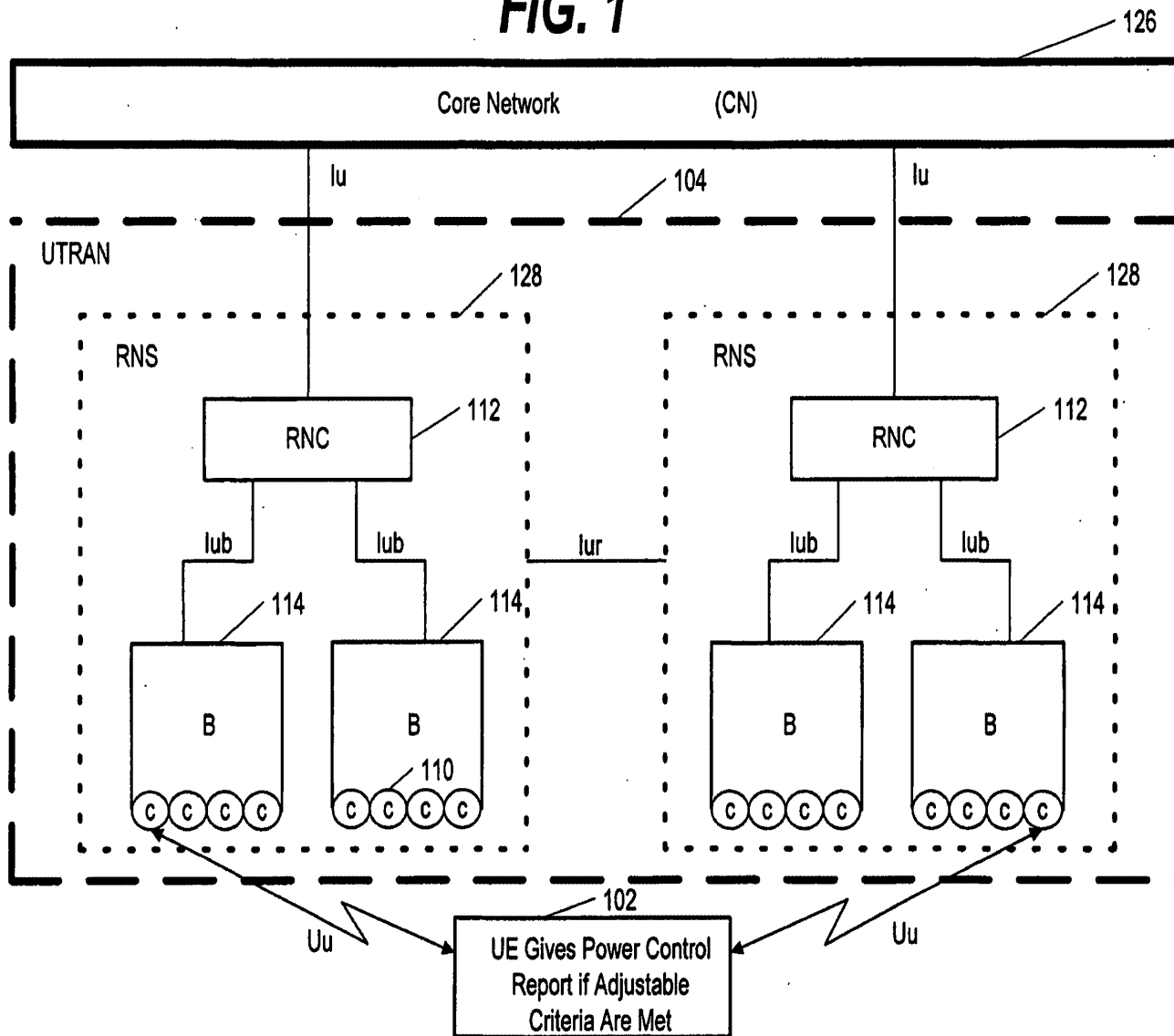

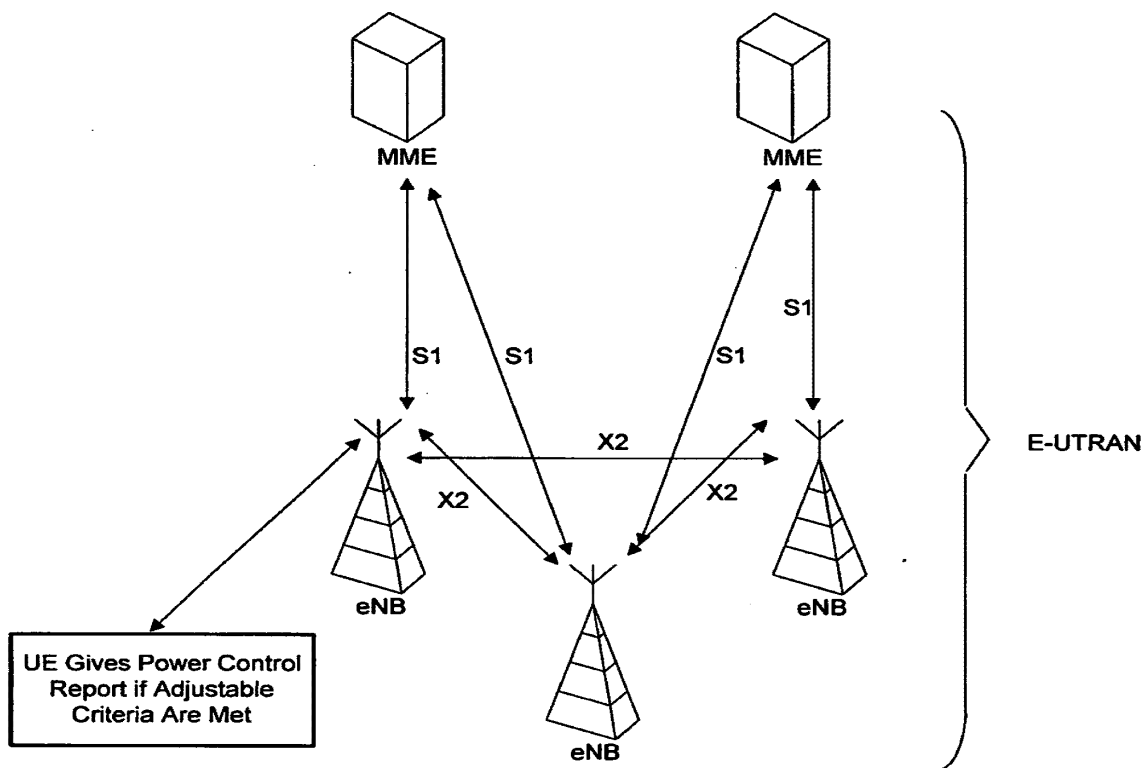

FIG. 2

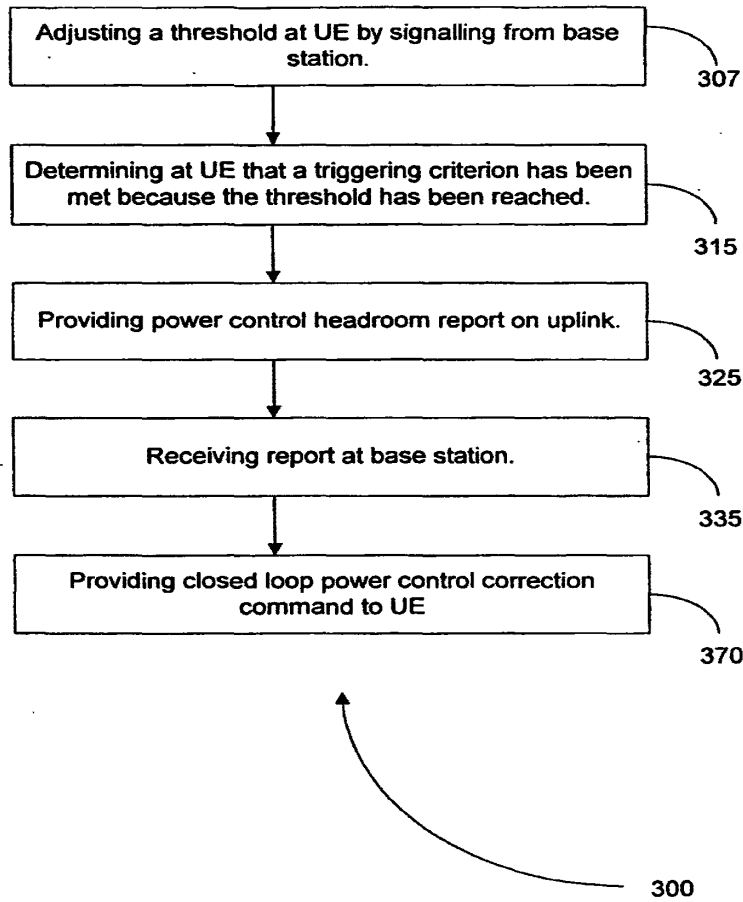

FIG. 3

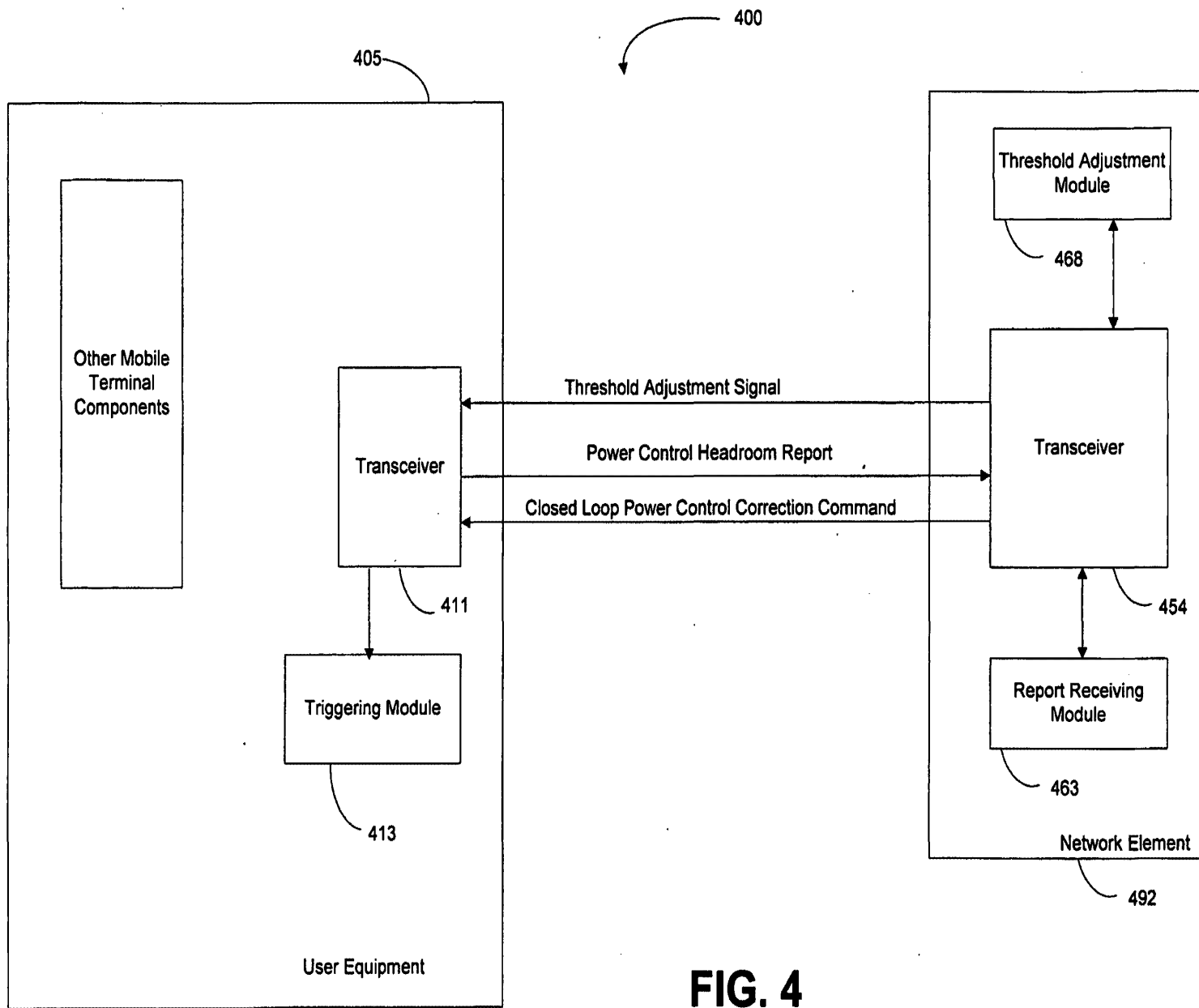

FIG. 4

**INFORMATION DISCLOSURE
CITATION FORM FOR
PATENT APPLICATION
(FORM PTO-1449)
(Substitute)**

Docket No.: 863.0156.U1(US)

Serial No.: 12/665,427

Applicant(s): Michel et al.

Filing Date: December 18, 2009

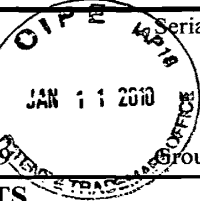

U.S. PATENT DOCUMENTS

Examiner Initials	Document Number (Number-Kind Code)	Publication Date (MM-DD-YYYY)	Name of Patentee or Applicant	Class	Sub-class
	US-				
	US-				
	US-				
	US-				
	US-				
	US-				
	US-				
	US-				
	US-				
	US-				
	US-				
	US-				
	US-				

FOREIGN PATENT DOCUMENTS

Examiner Initials	Document Number (Country Code-Number-Kind Code)	Publication Date (MM-DD-YYYY)	Name Of Patentee of Applicant	Translation? Yes/No/n/a
	- -			
	- -			
	- -			

OTHER DOCUMENTS (Author (Capitalize), Title, Date, Pages, Etc., if known)

	3GPP TS 36.300 V8.0.0 (2007-03); 3 rd Generation Partnership Project; Technical Specification Group Radio Access Network; Evolved Universal Terrestrial Radio Access (E-UTRA) and Evolved Universal Terrestrial Radio Access Network (E-UTRAN); Overall Description; Stage 2 (Release 8).

Examiner's Signature:

Date Considered:

Initial if reference was considered, whether or not citation is in conformance with MPEP. Mark through citation if not considered. Include a copy of this citation form with your next correspondence to the Applicant(s).



ELW

IN THE UNITED STATES PATENT AND TRADEMARK OFFICE

Application No.: 12/665,427 Confirmation No.: 1011
Applicant(s): Michel et al.
Filed: December 18, 2009
Art Unit: N/A
Examiner:

Title: Power Headroom Reporting Method

Attorney Docket No.: 863.0156.U1(US)

Commissioner For Patents
P.O. Box 1450
Alexandria, VA 22313-1450

Supplemental Information Disclosure Statement
(37 C.F.R. §1.97(b))

Sir:

The following information is being disclosed to the U.S. Patent and Trademark Office as information that may be material to the examination of the above-identified patent application.

Applicant's Attorney is aware of the documents listed on the enclosed Form PTO-1449. Copies of the non-US documents are enclosed with the Form PTO-1449 for the Examiner's use.

The filing of this Statement is not to be construed as a representation that a search has been made regarding the claimed invention (37 C.F.R. §1.97(g)) or that no other possible

material information exists. In addition, the filing of this Statement is not to be construed to be an admission that the information cited in the Statement is, or is considered to be, material to Patentability (37 C.F.R. §1.97(h)).

Respectfully submitted,



Harry F. Smith (Reg. No. 32,493)
Customer No.: 29683
Harrington & Smith, Attorneys at Law, LLC
4 Research Drive
Shelton, CT 06484-6212
203-925-9400

1/6/2010
Date

CERTIFICATE OF MAILING

I hereby certify that this correspondence is being deposited with the United States Postal Service as first class mail on the date shown below in an envelope addressed to:
Commissioner for Patents, P.O. Box 1450, Alexandria, VA 22313-1450.

1-6-2010
Date

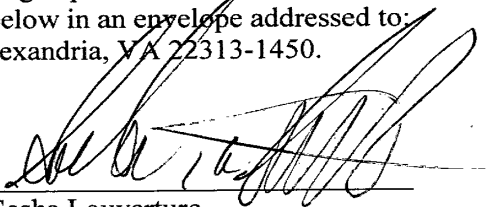

Sasha Louverture

FORM PTO-1390 (Modified) U.S. PATENT AND TRADEMARK OFFICE; U.S. DEPARTMENT OF COMMERCE (REV. 9-2006)		ATTORNEY'S DOCKET NUMBER 863.0156.U1(US)
TRANSMITTAL LETTER TO THE UNITED STATES DESIGNATED/ELECTED OFFICE (DO/EO/US) CONCERNING A SUBMISSION UNDER 35 U.S.C. 371		U.S. APPLICATION NO. (If known, see 37 CFR 1.5) 12/665,427
		PRIORITY DATE CLAIMED 20 June 2007
INTERNATIONAL APPLICATION NO. PCT/FI2008/050384	INTERNATIONAL FILING DATE 23 June 2008	
TITLE OF INVENTION Power Headroom Reporting Method		
APPLICANT(S) FOR DO/EO/US Juergen MICHEL, Klaus Ingemann PEDERSEN, Claudio ROSA		
Applicant herewith submits to the United States Designated/Elected Office (DO/EO/US) the following items and other information:		
<ol style="list-style-type: none"> 1. <input type="checkbox"/> This is a FIRST submission of items concerning a submission under 35 U.S.C. 371. 2. <input checked="" type="checkbox"/> This is a SECOND or SUBSEQUENT submission of items concerning a submission under 35 U.S.C. 371. 3. <input type="checkbox"/> This is an express request to begin national examination procedures (35 U.S.C. 371(f)). The submission must include items (5), (6), (9) and (25) indicated below. 4. <input type="checkbox"/> The US has been elected (Article 31). 5. <input type="checkbox"/> A copy of the International Application as filed (35 U.S.C. 371 (c)(2)) <ol style="list-style-type: none"> a. <input type="checkbox"/> is attached hereto (required only if not communicated by the International Bureau). b. <input type="checkbox"/> has been communicated by the International Bureau. c. <input type="checkbox"/> is not required, as the application was filed in the United States Receiving Office (RO/US). 6. <input type="checkbox"/> An English language translation of the International Application as filed (35 U.S.C. 371(c)(2)). <ol style="list-style-type: none"> a. <input type="checkbox"/> is attached hereto. b. <input type="checkbox"/> has been previously submitted under 35 U.S.C. 154(d)(4). 7. <input type="checkbox"/> Amendments to the claims of the International Application under PCT Article 19 (35 U.S.C. 371 (c)(3)) <ol style="list-style-type: none"> a. <input type="checkbox"/> are attached hereto (required only if not communicated by the International Bureau). b. <input type="checkbox"/> have been communicated by the International Bureau. c. <input type="checkbox"/> have not been made; however, the time limit for making such amendments has NOT expired. d. <input type="checkbox"/> have not been made and will not be made. 8. <input type="checkbox"/> An English language translation of the amendments to the claims under PCT Article 19 (35 U.S.C. 371(c)(3)). 9. <input checked="" type="checkbox"/> An oath or declaration of the inventor(s) (35 U.S.C. 371 (c)(4)). 10. <input type="checkbox"/> An English language translation of the annexes to the International Preliminary Examination Report under PCT Article 36 (35 U.S.C. 371 (c)(5)). 11. <input type="checkbox"/> A copy of the International Preliminary Examination Report (PCT/IPEA/409). 12. <input type="checkbox"/> A copy of the International Search Report (PCT/ISA/210). <p>Items 13 to 23 below concern document(s) or information included:</p> <ol style="list-style-type: none"> 13. <input type="checkbox"/> An Information Disclosure Statement under 37 CFR 1.97 and 1.98. 14. <input type="checkbox"/> An assignment document for recording. A separate cover sheet in compliance with 37 CFR 3.28 and 3.31 is included. 15. <input type="checkbox"/> A FIRST preliminary amendment. 16. <input type="checkbox"/> A SECOND or SUBSEQUENT preliminary amendment. 17. <input type="checkbox"/> An Application Data Sheet under 37 CFR 1.76. 18. <input type="checkbox"/> A substitute specification. 19. <input type="checkbox"/> A power of attorney and/or change of address letter. 20. <input type="checkbox"/> A computer-readable form of the sequence listing in accordance with PCT Rule 13ter.2 and 37 CFR 1.821 - 1.825. 21. <input type="checkbox"/> A second copy of the published International Application under 35 U.S.C. 154(d)(4). 22. <input type="checkbox"/> A second copy of the English language translation of the International Application under 35 U.S.C. 154(d)(4). 23. <input type="checkbox"/> Express Mail Label No. 		

Under the Paperwork Reduction Act of 1995, no persons are required to respond to a collection of information unless it displays a valid OMB control number.

U.S. APPLICATION NO (if known, see 37 CFR 1.5) 12/665,427	INTERNATIONAL APPLICATION NO. PCT/FI2008/050384	ATTORNEY'S DOCKET NUMBER 863.0156.U1(US)
24. Other items or information:		
The following fees have been submitted:		CALCULATIONS
25. <input type="checkbox"/> Basic national fee (37 CFR 1.492(a)). \$330		PTO USE
		\$ \$0.00
26. <input type="checkbox"/> Examination fee (37 CFR 1.492(c)) If the written opinion prepared by ISA/US or the international preliminary examination report prepared by IPEA/US indicates all claims satisfy provisions of PCT Article prepared by IPEA/US indicates all claims satisfy provisions of PCT Article \$0 All other situations. \$220		\$ \$0.00
27. <input type="checkbox"/> Search fee (37 CFR 1.492(b)) If the written opinion of the ISA/US or the International preliminary examination report prepared by IPEA/US indicates all claims satisfy provisions of PCT Article 33(1)-(4). . . \$0 Search fee (37 CFR 1.445(a)(2)) has been paid on the international application to the USPTO as an International Searching Authority. \$100 International Search Report prepared by an ISA other than the US and provided to the Office or previously communicated to the US by the IB. \$430 All other situations. \$540		\$ \$0.00
TOTAL OF 25, 26 and 27 =		\$ \$0.00
<input type="checkbox"/> Additional fee for specification and drawings filed in paper over 100 sheets (excluding sequence listing in compliance with 37 CFR 1.821(c) or (e) in an electronic medium or computer program listing in an electronic medium) (37 CFR 1.492(j)). The fee is \$270 for each additional 50 sheets of paper or fraction thereof.		
Total Sheets	Extra Sheets	Number of each additional 50 or fraction thereof (round up to a whole)
- 100 =	0 /50 =	0
		x \$270.00
		\$ \$0.00
Surcharge of \$130.00 for furnishing any of the search fee, examination fee, or the oath or declaration after the date of commencement of the national stage (37 CFR 1.492(h)).		\$ 130
CLAIMS	NUMBER FILED	NUMBER EXTRA
Total claims	- 20 =	0
		x \$52.00
		\$ \$0.00
Independent claims	- 3 =	0
		x \$220.00
		\$ \$0.00
MULTIPLE DEPENDENT CLAIMS (if applicable) <input type="checkbox"/>		+ \$390.00
		\$ \$0.00
TOTAL OF ABOVE CALCULATIONS =		\$ \$130.00
<input type="checkbox"/> Applicant claims small entity status. See 37 CFR 1.27. Fees above are reduced by 1/2.		
SUBTOTAL =		\$ \$130.00
Processing fee of \$130.00 for furnishing the English translation later than 30 months from the earliest claimed priority date (37 CFR 1.492(i)).		\$ \$0.00
TOTAL NATIONAL FEE =		\$ \$130.00
Fee for recording the enclosed assignment (37 CFR 1.21(h)). The assignment must be accompanied by an appropriate cover sheet (37 CFR 3.28, 3.31). \$40 per property +		\$ \$0.00
TOTAL FEES ENCLOSED =		\$ \$130.00
		Amount to be \$
		Amount to be \$

Under the Paperwork Reduction Act of 1995, no persons are required to respond to a collection of information unless it displays a valid OMB control number.

- a. A check in the amount of \$ _____ to cover the above fees is enclosed.
- b. Please charge my Deposit Account No. 50-1924 in the amount of \$ \$130.00 to cover the above fees.
A duplicate copy of this sheet is enclosed.
- c. The Commissioner is hereby authorized to charge any additional fees which may be required, or credit any overpayment to Deposit Account No. 50-1924. A duplicate copy of this sheet is enclosed.
- d. Fees are to be charged to a credit card. **WARNING:** Information on this form may become public. **Credit card information should not be included on this form.** Provide credit card information and authorization on PTO-2038. The PTO-2038 should only be mailed or faxed to the USPTO. However, when paying the basic national fee, the PTO-2038 may NOT be faxed to the USPTO.

ADVISORY: If filing by EFS-Web, do NOT attach the PTO-2038 form as a PDF along with your EFS-Web submission. Please be advised that this is not recommended and by doing so your credit card information may be displayed via PAIR. To

NOTE: Where an appropriate time limit under 37 CFR 1.495 has not been met, a petition to revive (37 CFR 1.137(a) or (b)) must be filed and granted to restore the International Application to pending status.

SEND ALL CORRESPONDENCE TO:

Customer No. 29,683
Harrington & Smith,
Attorneys At Law, LLC
4 Research Drive
Shelton, CT 06484-6212

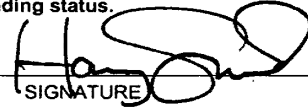
SIGNATURE

Harry F. Smith

NAME

32,493

REGISTRATION NUMBER

1/19/2010

DATE

01/22/2010 LLANDGRA 00000100 501924 12665427

01 FC:1617 130.00 DA

Declaration and Power of Attorney For Patent Application
Erklärung Für Patentanmeldungen Mit Vollmacht
German Language Declaration

Als nachstehend benannter Erfinder erkläre ich hiermit an Eides Statt:

As a below named Inventor, I hereby declare that:

dass mein Wohnsitz, meine Postanschrift, und meine Staatsangehörigkeit den im Nachstehenden nach meinem Namen aufgeführten Angaben entsprechen, dass ich, nach bestem Wissen der ursprüngliche, erste und alleinige Erfinder (falls nachstehend nur ein Name angegeben ist) oder ein ursprünglicher, erster und Miterfinder (falls nachstehend mehrere Namen aufgeführt sind) des Gegenstandes bin, für den dieser Antrag gestellt wird und für den ein Patent für die Erfindung mit dem Titel beantragt wird:

My residence, post office address and citizenship are as stated below next to my name,

I believe I am the original, first and sole inventor (if only one name is listed below) or an original, first and joint inventor (if plural names are listed below) of the subject matter which is claimed and for which a patent is sought on the invention entitled

POWER HEADROOM REPORTING METHOD

POWER HEADROOM REPORTING METHOD

deren Beschreibung hier beigefügt ist, es sei denn (in diesem Falle Zutreffendes bitte ankreuzen), diese Erfindung

the specification of which is attached hereto unless the following box is checked:

wurde angemeldet am 23.06.2008 unter der US-Anmeldenummer oder unter der Internationalen Anmeldenummer im Rahmen des PCT-Vertrags PCT/FI2008/050384, und am _____ abgeändert (falls zutreffend).

was filed on 23.06.2008 as United States Application Number or PCT International Application Number PCT/FI2008/050384 and was amended on _____ (if applicable).

Ich bestätige hiermit, dass ich den Inhalt der obigen Patentanmeldung einschliesslich der Ansprüche, die eventuell durch einen Zusatzantrag wie oben erwähnt abgeändert wurde, durchgesehen und verstanden habe.

I hereby state that I have reviewed and understand the contents of the above identified specification, including the claims, as amended by any amendment referred to above.

Ich erkenne meine Pflicht zur Offenbarung jeglicher Informationen an, die zur Prüfung der Patentfähigkeit in Einklang mit Titel 37, Code of Federal Regulations, § 1.56 von Belang sind.

I acknowledge the duty to disclose information which is material to patentability as defined in Title 37, Code of Federal Regulations, § 1.56.

Ich beanspruche hiermit ausländische Prioritätsvorteile gemäß Title 35, United States Code, § US-Code, § 119 (a)-(d), bzw. § 365(b) aller unten aufgeführten Auslandsanmeldungen für Patente oder Erfinderurkunden, oder § 365(a) aller PCT internationalen Anmeldungen, welche wenigstens ein Land ausser den Vereinigten Staaten von Amerika benennen, und habe nachstehend durch ankreuzen sämtliche Auslandsanmeldungen für Patente bzw. Erfinderurkunden oder PCT Internationale Anmeldungen angegeben, deren Anmeldetag dem der Anmeldung, für welche Priorität beansprucht wird, vorangeht.

I hereby claim foreign priority under Title 35, 119(a)-(d) or § 365(b) of any foreign application(s) for patent or inventor's certificate, or § 365(a) of any PCT International application which designated at least one country other than the United States, listed below and have also identified below, by checking the box, any foreign application for patent or inventor's certificate, or PCT International application having a filing date before that of the application on which priority is claimed.

German Language Declaration

Prior foreign applications
Priorität beansprucht

Priority Claimed

60/936,649
(Number)
(Nummer)

US
(Country)
(Land)

20.06.2007
(Day Month Year Filed)
(Tag Monat Jahr eingereicht)

Yes No
Ja Nein

(Number)
(Nummer)

(Country)
(Land)

(Day Month Year Filed)
(Tag Monat Jahr eingereicht)

Yes No
Ja Nein

(Number)
(Nummer)

(Country)
(Land)

(Day Month Year Filed)
(Tag Monat Jahr eingereicht)

Yes No
Ja Nein

(Number)
(Nummer)

(Country)
(Land)

(Day Month Year Filed)
(Tag Monat Jahr eingereicht)

Yes No
Ja Nein

Ich beanspruche hiermit die mir unter Title 35, US-Code, § 120 zustehenden Vorteile aller unten aufgeführten US-Patentanmeldungen bzw. § 365(c) aller PCT internationalen Anmeldungen, welche die Vereinigten Staaten von Amerika benennen, und erkenne, insofern der Gegenstand eines jeden früheren Anspruchs dieser Patentanmeldung nicht in einer US-Patentanmeldung, bzw. PCT internationalen Anmeldung in einer gemäß dem ersten Absatz von Title 35, US-Code, § 112 vorgeschriebenen Art und Weise offenbart wurde, meine Pflicht zur Offenbarung jeglicher Informationen an, die zur Prüfung der Patentfähigkeit in Einklang mit Title 37, Code of Federal Regulations, § 1.56 von Belang sind und die im Zeitraum zwischen dem Anmeldetag der früheren Patentanmeldung und dem nationalen oder im Rahmen des Vertrags über die Zusammenarbeit auf dem Gebiet des Patentwesens (PCT) gültigen internationalen Anmeldetags bekannt geworden sind.

I hereby claim the benefit under Title 35, United States Code, § 120 of any United States application(s), or § 365(c) of any PCT International application designating the United States, listed below and, insofar as the subject matter of each of the claims of this application is not disclosed in the prior United States or PCT International application in the manner provided by the first paragraph of Title 35, United States Code, § 112, I acknowledge the duty to disclose information which is material to patentability as defined in Title 37, Code of Federal Regulations, § 1.56 which became available between the filing date of the prior application and the national or PCT International filing date of this application.

PCT/FI2008/050384
(Application Serial No.)
(Anmeldeseriennummer)

23.06.2008
(Filing Date D, M, Y)
(Anmeldedatum T, M, J)

anhängig
(Status)
(patentiert, anhängig,
aufgegeben)

pending
(Status)
(patented, pending,
abandoned)

(Application Serial No.)
(Anmeldeseriennummer)

(Filing Date D, M, Y)
(Anmeldedatum T, M, J)

(Status)
(patentiert, anhängig,
aufgeben)

(Status)
(patented, pending,
abandoned)

Ich erkläre hiermit, daß alle in der vorliegenden Erklärung von mir gemachten Angaben nach bestem Wissen und Gewissen der Wahrheit entsprechen, und ferner daß ich diese eidesstattliche Erklärung in Kenntnis dessen ablege, daß wissentlich und vorsätzlich falsche Angaben oder dergleichen gemäß § 1001, Title 18 des US-Code strafbar sind und mit Geldstrafe und/oder Gefängnis bestraft werden können und daß derartige wissentlich und vorsätzlich falsche Angaben die Rechtswirksamkeit der vorliegenden Patentanmeldung oder eines aufgrund deren erteilten Patentes gefährden können.

I hereby declare that all statements made herein of my own knowledge are true and that all statements made on information and belief are believed to be true; and further that these statements were made with the knowledge that willful false statements and the like so made are punishable by fine or imprisonment, or both, under Section 1001 of Title 18 of the United States Code and that such willful false statements may jeopardize the validity of the application or any patent issued thereon.

German Language Declaration

VERTRETUNGSVOLLMACHT: Als benannter Erfinder beauftrage ich hiermit den (die) nachstehend aufgeführten Patentanwalt (Patentanwälte) und/oder Vertreter mit der Verfolgung der vorliegenden Patentanmeldung sowie mit der Abwicklung aller damit verbundenen Angelegenheiten vor dem US-Patent- und Markenamt: (Name(n) und Registrationsnummer(n) auflisten)

POWER OF ATTORNEY: As a named inventor, I hereby appoint the following attorney(s) and/or agent(s) to prosecute this application and transact all business in the Patent and Trademark Office connected therewith: (list name and registration number)

Customer No. _____

And I hereby appoint

Telefongespräche bitte richten an:
(Name und Telefonnummer)

Direct Telephone Calls to: (name and telephone number)

Ext. _____

Postanschrift:

Send Correspondence to:

Harrington & Smith, LLP
4 Research Drive Shelton, Connecticut 06484-6212 UNITED STATES OF AMERICA
Telephone: +1 203 925 9400 and Facsimile +1 203 944 0245

or
Customer No. _____

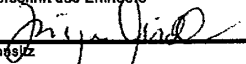
Voller Name des einzigen oder ursprünglichen Erfinders: Juergen Michel	Full name of sole or first inventor: Juergen Michel
Unterschrift des Erfinders  Datum 14.1.10	Inventor's signature Date
Wohnsitz München, GERMANY	Residence München, GERMANY
Staatsangehörigkeit DE	Citizenship DE
Postanschrift Hadorfer Str. 8	Post Office Address Hadorfer Str. 8
81475 München GERMANY	81475 München GERMANY
Voller Name des zweiten Miterfinders (falls zutreffend): Klaus Ingemann Pedersen	Full name of second joint inventor, if any: Klaus Ingemann Pedersen
Unterschrift des Erfinders Datum	Inventor's signature Date
Wohnsitz Aalborg, DENMARK	Residence Aalborg, DENMARK
Staatsangehörigkeit DK	Citizenship DK
Postanschrift Laesogade 9, 3 th	Post Office Address Laesogade 9, 3 th
9000 Aalborg DENMARK	9000 Aalborg DENMARK

(Bitte entsprechende Informationen und Unterschriften im Falle von dritten und weiteren Miterfindern angeben).

(Supply similar information and signature for third and subsequent joint inventors).

Voller Name des dritten Miterfinders:		Full name of third joint inventor:	
Claudio Rosa		Claudio Rosa	
Unterschrift des Erfinders	Datum	Inventor's signature	Date
Wohnsitz		Residence	
Randers, DENMARK		Randers, DENMARK	
Staatsangehörigkeit		Citizenship	
IT		IT	
Postanschrift		Post Office Address	
Krebsen 14		Krebsen 14	
8900 Randers DENMARK		8900 Randers DENMARK	
Voller Name des vierten Miterfinders:		Full name of fourth joint inventor:	
Unterschrift des Erfinders	Datum	Inventor's signature	Date
Wohnsitz		Residence	
,		,	
Staatsangehörigkeit		Citizenship	
Postanschrift		Post Office Address	
Voller Name des fünften Miterfinders:		Full name of fifth joint inventor:	
Unterschrift des Erfinders	Datum	Inventor's signature	Date
Wohnsitz		Residence	
,		,	
Staatsangehörigkeit		Citizenship	
Postanschrift		Post Office Address	
Voller Name des sechsten Miterfinders:		Full name of sixth joint inventor:	
Unterschrift des Erfinders	Datum	Inventor's signature	Date
Wohnsitz		Residence	
,		,	
Staatsangehörigkeit		Citizenship	
Postanschrift		Post Office Address	

(Bitte entsprechende Informationen und Unterschriften im Falle von dritten und weiteren Miterfindern angeben). (Supply similar information and signature for third and subsequent joint inventors).

Declaration and Power of Attorney For Patent Application
Erklärung Für Patentanmeldungen Mit Vollmacht
 German Language Declaration

Als nachstehend benannter Erfinder erkläre ich hiermit an Eldes Statt:

As a below named inventor, I hereby declare that:

dass mein Wohnsitz, meine Postanschrift, und meine Staatsangehörigkeit den im Nachstehenden nach meinem Namen aufgeführten Angaben entsprechen, dass ich, nach bestem Wissen der ursprüngliche, erste und alleinige Erfinder (falls nachstehend nur ein Name angegeben ist) oder ein ursprünglicher, erster und Miterfinder (falls nachstehend mehrere Namen aufgeführt sind) des Gegenstandes bin, für den dieser Antrag gestellt wird und für den ein Patent für die Erfindung mit dem Titel beantragt wird:

My residence, post office address and citizenship are as stated below next to my name.

I believe I am the original, first and sole inventor (if only one name is listed below) or an original, first and joint inventor (if plural names are listed below) of the subject matter which is claimed and for which a patent is sought on the invention entitled

POWER HEADROOM REPORTING METHOD

POWER HEADROOM REPORTING METHOD

deren Beschreibung hier beigefügt ist, es sei denn (in diesem Falle Zutreffendes bitte ankreuzen), diese Erfindung

the specification of which is attached hereto unless the following box is checked:

wurde angemeldet am 23.06.2008 unter der US-Anmeldenummer oder unter der Internationalen Anmeldenummer im Rahmen des PCT-Vertrags PCT/FI2008/050384 und am _____ abgeändert (falls zutreffend).

was filed on 23.06.2008 as United States Application Number or PCT International Application Number PCT/FI2008/050384 and was amended on _____ (if applicable).

Ich bestätige hiermit, dass ich den Inhalt der obigen Patentanmeldung einschliesslich der Ansprüche, die eventuell durch einen Zusatzantrag wie oben erwähnt abgeändert wurde, durchgesehen und verstanden habe.

I hereby state that I have reviewed and understand the contents of the above identified specification, including the claims, as amended by any amendment referred to above.

Ich erkenne meine Pflicht zur Offenbarung jeglicher Informationen an, die zur Prüfung der Patentfähigkeit in Einklang mit Titel 37, Code of Federal Regulations, § 1.56 von Belang sind.

I acknowledge the duty to disclose information which is material to patentability as defined in Title 37, Code of Federal Regulations, § 1.56.

Ich beanspruche hiermit ausländische Prioritätsvorteile gemäß Title 35, United States Code, § US-Code, § 119 (a)-(d), bzw. § 365(b) aller unten aufgeführten Auslandsanmeldungen für Patente oder Erfinderurkunden, oder § 365(a) aller PCT internationalen Anmeldungen, welche wenigstens ein Land ausser den Vereinigten Staaten von Amerika benennen, und habe nachstehend durch ankreuzen sämtliche Auslandsanmeldungen für Patente bzw. Erfinderurkunden oder PCT internationale Anmeldungen angegeben, deren Anmeldetag dem der Anmeldung, für welche Priorität beansprucht wird, vorangeht.

I hereby claim foreign priority under Title 35, 119(a)-(d) or § 365(b) of any foreign application(s) for patent or inventor's certificate, or § 365(a) of any PCT International application which designated at least one country other than the United States, listed below and have also identified below, by checking the box, any foreign application for patent or inventor's certificate, or PCT International application having a filing date before that of the application on which priority is claimed.

German Language Declaration

Prior foreign applications
Priorität beansprucht

Priority Claimed

60/936,649 US 20.06.2007
(Number) (Country) (Day Month Year Filed)
(Nummer) (Land) (Tag Monat Jahr eingereicht)

Yes No
Ja Nein

(Number) (Country) (Day Month Year Filed)
(Nummer) (Land) (Tag Monat Jahr eingereicht)

Yes No
Ja Nein

(Number) (Country) (Day Month Year Filed)
(Nummer) (Land) (Tag Monat Jahr eingereicht)

Yes No
Ja Nein

(Number) (Country) (Day Month Year Filed)
(Nummer) (Land) (Tag Monat Jahr eingereicht)

Yes No
Ja Nein

Ich beanspruche hiermit die mir unter Title 35, US-Code, § 120 zustehenden Vorteile aller unten aufgeführten US-Patentanmeldungen bzw. § 365(c) aller PCT internationalen Anmeldungen, welche die Vereinigten Staaten von Amerika benennen, und erkenne, insofern der Gegenstand eines jeden früheren Anspruchs dieser Patentanmeldung nicht in einer US-Patentanmeldung, bzw. PCT internationalen Anmeldung in einer gemäß dem ersten Absatz von Title 35, US-Code, § 112 vorgeschriebenen Art und Weise offenbart wurde, meine Pflicht zur Offenbarung jeglicher Informationen an, die zur Prüfung der Patentfähigkeit in Einklang mit Title 37, Code of Federal Regulations, § 1.56 von Belang sind und die im Zeitraum zwischen dem Anmeldetag der früheren Patentanmeldung und dem nationalen oder im Rahmen des Vertrags über die Zusammenarbeit auf dem Gebiet des Patentwesens (PCT) gültigen internationalen Anmeldetags bekannt geworden sind.

I hereby claim the benefit under Title 35, United States Code, § 120 of any United States application(s), or § 365(c) of any PCT International application designating the United States, listed below and, insofar as the subject matter of each of the claims of this application is not disclosed in the prior United States or PCT International application in the manner provided by the first paragraph of Title 35, United States Code, § 112, I acknowledge the duty to disclose information which is material to patentability as defined in Title 37, Code of Federal Regulations, § 1.56 which became available between the filing date of the prior application and the national or PCT International filing date of this application.

PCT/FI2008/050384 23.06.2008
(Application Serial No.) (Filing Date D, M, Y)
(Anmeldeseriennummer) (Anmeldedatum T, M, J)

anhängig
(Status)
(patentiert, anhängig,
aufgegeben)

pending
(Status)
(patented, pending,
abandoned)

(Application Serial No.) (Filing Date D,M,Y)
(Anmeldeseriennummer) (Anmeldedatum T, M, J)

(Status)
(patentiert, anhängig,
aufgeben)

(Status)
(patented, pending,
abandoned)

Ich erkläre hiermit, daß alle in der vorliegenden Erklärung von mir gemachten Angaben nach bestem Wissen und Gewissen der Wahrheit entsprechen, und ferner daß ich diese eidesstattliche Erklärung in Kenntnis dessen ablege, daß wissentlich und vorsätzlich falsche Angaben oder dergleichen gemäß § 1001, Title 18 des US-Code strafbar sind und mit Geldstrafe und/oder Gefängnis bestraft werden können und daß derartige wissentlich und vorsätzlich falsche Angaben die Rechtswirksamkeit der vorliegenden Patentanmeldung oder eines aufgrund deren erteilten Patentes gefährden können.

I hereby declare that all statements made herein of my own knowledge are true and that all statements made on information and belief are believed to be true; and further that these statements were made with the knowledge that willful false statements and the like so made are punishable by fine or imprisonment, or both, under Section 1001 of Title 18 of the United States Code and that such willful false statements may jeopardize the validity of the application or any patent issued thereon.

German Language Declaration

VERTRETUNGSVOLLMACHT: Als benannter Erfinder beauftrage ich hiermit den (die) nachstehend aufgeführten Patentanwalt (Patentanwälte) und/oder Vertreter mit der Verfolgung der vorliegenden Patentanmeldung sowie mit der Abwicklung aller damit verbundenen Angelegenheiten vor dem US-Patent- und Markenamt: (Name(n) und Registrationsnummer(n) auflisten)

POWER OF ATTORNEY: As a named inventor, I hereby appoint the following attorney(s) and/or agent(s) to prosecute this application and transact all business in the Patent and Trademark Office connected therewith: (list name and registration number)

Customer No. _____

And I hereby appoint

Telefongespräche bitte richten an:
(Name und Telefonnummer)

Direct Telephone Calls to: (name and telephone number)

Ext. _____

Postanschrift:

Send Correspondence to:

Harrington & Smith, LLP
4 Research Drive Shelton, Connecticut 06484-6212 UNITED STATES OF AMERICA
Telephone: +1 203 925 9400 and Facsimile +1 203 944 0245

or
Customer No. _____

Voller Name des einzigen oder ursprünglichen Erfinders: Juergen Michel		Full name of sole or first inventor: Juergen Michel	
Unterschrift des Erfinders	Datum	Inventor's signature	Date
Wohnsitz München, GERMANY		Residence München, GERMANY	
Staatsangehörigkeit DE		Citizenship DE	
Postanschrift Hadorfer Str. 8		Post Office Address Hadorfer Str. 8	
81475 München		81475 München	
GERMANY		GERMANY	
Voller Name des zweiten Miterfinders (falls zutreffend): Klaus Ingemann Pedersen		Full name of second joint inventor, if any: Klaus Ingemann Pedersen	
Unterschrift des Erfinders	Datum	Inventor's signature	Date
Wohnsitz Aalborg, DENMARK		Residence Aalborg, DENMARK	
Staatsangehörigkeit DK		Citizenship DK	
Postanschrift Laesogade 9, 3 th		Post Office Address Laesogade 9, 3 th	
9000 Aalborg		9000 Aalborg	
DENMARK		DENMARK	

(Bitte entsprechende Informationen und Unterschriften im Falle von dritten und weiteren Miterfindern angeben).

(Supply similar information and signature for third and subsequent joint inventors).

Voller Name des dritten Miterfinders: Claudio Rosa		Full name of third joint inventor: Claudio Rosa	
Unterschrift des Erfinders	Datum	Inventor's signature	Date
Wohnsitz Randers, DENMARK		Residence Randers, DENMARK	
Staatsangehörigkeit IT		Citizenship IT	
Postanschrift Krebsen 14		Post Office Address Krebsen 14	
8900 Randers		8900 Randers	
DENMARK		DENMARK	
Voller Name des vierten Miterfinders:		Full name of fourth joint inventor:	
Unterschrift des Erfinders	Datum	Inventor's signature	Date
Wohnsitz		Residence	
Staatsangehörigkeit		Citizenship	
Postanschrift		Post Office Address	
Voller Name des fünften Miterfinders:		Full name of fifth joint inventor:	
Unterschrift des Erfinders	Datum	Inventor's signature	Date
Wohnsitz		Residence	
Staatsangehörigkeit		Citizenship	
Postanschrift		Post Office Address	
Voller Name des sechsten Miterfinders:		Full name of sixth joint inventor:	
Unterschrift des Erfinders	Datum	Inventor's signature	Date
Wohnsitz		Residence	
Staatsangehörigkeit		Citizenship	
Postanschrift		Post Office Address	

(Bitte entsprechende Informationen und Unterschriften im Falle von dritten und weiteren Miterfindern angeben).

(Supply similar information and signature for third and subsequent joint inventors).

Declaration and Power of Attorney For Patent Application
Erklärung Für Patentanmeldungen Mit Vollmacht
German Language Declaration

Als nachstehend benannter Erfinder erkläre ich hiermit an Eides Statt:

dass mein Wohnsitz, meine Postanschrift, und meine Staatsangehörigkeit den im Nachstehenden nach meinem Namen aufgeführten Angaben entsprechen, dass ich, nach bestem Wissen der ursprüngliche, erste und alleinige Erfinder (falls nachstehend nur ein Name angegeben ist) oder ein ursprünglicher, erster und Miterfinder (falls nachstehend mehrere Namen aufgeführt sind) des Gegenstandes bin, für den dieser Antrag gestellt wird und für den ein Patent für die Erfindung mit dem Titel beantragt wird:

POWER HEADROOM REPORTING METHOD

deren Beschreibung hier beigefügt ist, es sei denn (in diesem Falle Zutreffendes bitte ankreuzen), diese Erfindung

- wurde angemeldet am 23.06.2008 unter der US-Anmeldenummer oder unter der Internationalen Anmeldenummer im Rahmen des PCT-Vertrags PCT/FI2008/050384 und am _____ abgeändert (falls zutreffend).

Ich bestätige hiermit, dass ich den Inhalt der obigen Patentanmeldung einschliesslich der Ansprüche, die eventuell durch einen Zusatzantrag wie oben erwähnt abgeändert wurde, durchgesehen und verstanden habe.

Ich erkenne meine Pflicht zur Offenbarung jeglicher Informationen an, die zur Prüfung der Patentfähigkeit in Einklang mit Titel 37, Code of Federal Regulations, § 1.56 von Belang sind.

Ich beanspruche hiermit ausländische Prioritätsvorteile gemäß Title 35, United States Code, § US-Code, § 119 (a)-(d), bzw. § 365(b) aller unten aufgeführten Auslandsanmeldungen für Patente oder Erfinderurkunden, oder § 365(a) aller PCT internationalen Anmeldungen, welche wenigstens ein Land ausser den Vereinigten Staaten von Amerika benennen, und habe nachstehend durch ankreuzen sämtliche Auslandsanmeldungen für Patente bzw. Erfinderurkunden oder PCT internationale Anmeldungen angegeben, deren Anmeldetag dem der Anmeldung, für welche Priorität beansprucht wird, vorangeht.

As a below named inventor, I hereby declare that:

My residence, post office address and citizenship are as stated below next to my name,

I believe I am the original, first and sole inventor (if only one name is listed below) or an original, first and joint inventor (if plural names are listed below) of the subject matter which is claimed and for which a patent is sought on the invention entitled

POWER HEADROOM REPORTING METHOD

the specification of which is attached hereto unless the following box is checked:

- was filed on 23.06.2008 as United States Application Number or PCT International Application Number PCT/FI2008/050384 and was amended on _____ (if applicable).

I hereby state that I have reviewed and understand the contents of the above identified specification, including the claims, as amended by any amendment referred to above.

I acknowledge the duty to disclose information which is material to patentability as defined in Title 37, Code of Federal Regulations, § 1.56.

I hereby claim foreign priority under Title 35, 119(a)-(d) or § 365(b) of any foreign application(s) for patent or inventor's certificate, or § 365(a) of any PCT International application which designated at least one country other than the United States, listed below and have also identified below, by checking the box, any foreign application for patent or inventor's certificate, or PCT International application having a filing date before that of the application on which priority is claimed.

German Language Declaration

Prior foreign applications
Priorität beansprucht

Priority Claimed

60/936.649

US

20.06.2007

Yes No
Ja Nein

(Number)
(Nummer)

(Country)
(Land)

(Day Month Year Filed)
(Tag Monat Jahr eingereicht)

(Number)
(Nummer)

(Country)
(Land)

(Day Month Year Filed)
(Tag Monat Jahr eingereicht)

Yes No
Ja Nein

(Number)
(Nummer)

(Country)
(Land)

(Day Month Year Filed)
(Tag Monat Jahr eingereicht)

Yes No
Ja Nein

(Number)
(Nummer)

(Country)
(Land)

(Day Month Year Filed)
(Tag Monat Jahr eingereicht)

Yes No
Ja Nein

Ich beanspruche hiermit die mir unter Title 35, US-Code, § 120 zustehenden Vorteile aller unten aufgeführten US-Patentanmeldungen bzw. § 365(c) aller PCT internationalen Anmeldungen, welche die Vereinigten Staaten von Amerika benennen, und erkenne, insofern der Gegenstand eines jeden früheren Anspruchs dieser Patentanmeldung nicht in einer US-Patentanmeldung, bzw. PCT internationalen Anmeldung in einer gemäß dem ersten Absatz von Title 35, US-Code, § 112 vorgeschriebenen Art und Weise offenbart wurde, meine Pflicht zur Offenbarung jeglicher Informationen an, die zur Prüfung der Patentfähigkeit in Einklang mit Title 37, Code of Federal Regulations, § 1.56 von Belang sind und die im Zeitraum zwischen dem Anmeldetag der früheren Patentanmeldung und dem nationalen oder im Rahmen des Vertrags über die Zusammenarbeit auf dem Gebiet des Patentwesens (PCT) gültigen internationalen Anmeldetags bekannt geworden sind.

I hereby claim the benefit under Title 35, United States Code, § 120 of any United States application(s), or § 365(c) of any PCT International application designating the United States, listed below and, insofar as the subject matter of each of the claims of this application is not disclosed in the prior United States or PCT International application in the manner provided by the first paragraph of Title 35, United States Code, § 112, I acknowledge the duty to disclose information which is material to patentability as defined in Title 37, Code of Federal Regulations, § 1.56 which became available between the filing date of the prior application and the national or PCT International filing date of this application.

PCT/FI2008/050384
(Application Serial No.)
(Anmeldeseriennummer)

23.06.2008
(Filing Date D, M, Y)
(Anmeldedatum T, M, J)

anhängig
(Status)
(patentiert, anhängig,
aufgegeben)

pending
(Status)
(patented, pending,
abandoned)

(Application Serial No.)
(Anmeldeseriennummer)

(Filing Date D,M,Y)
(Anmeldedatum T, M, J)

(Status)
(patentiert, anhängig,
aufgeben)

(Status)
(patented, pending,
abandoned)

Ich erkläre hiermit, daß alle in der vorliegenden Erklärung von mir gemachten Angaben nach bestem Wissen und Gewissen der Wahrheit entsprechen, und ferner daß ich diese eidesstattliche Erklärung in Kenntnis dessen ablege, daß wissentlich und vorsätzlich falsche Angaben oder dergleichen gemäß § 1001, Title 18 des US-Code strafbar sind und mit Geldstrafe und/oder Gefängnis bestraft werden können und daß derartige wissentlich und vorsätzlich falsche Angaben die Rechtswirksamkeit der vorliegenden Patentanmeldung oder eines aufgrund deren erteilten Patentes gefährden können.

I hereby declare that all statements made herein of my own knowledge are true and that all statements made on information and belief are believed to be true; and further that these statements were made with the knowledge that willful false statements and the like so made are punishable by fine or imprisonment, or both, under Section 1001 of Title 18 of the United States Code and that such willful false statements may jeopardize the validity of the application or any patent issued thereon.

German Language Declaration

VERTRETUNGSVOLMACHT: Als benannter Erfinder beauftrage ich hiermit den (die) nachstehend aufgeführten Patentanwalt (Patentanwälte) und/oder Vertreter mit der Verfolgung der vorliegenden Patentanmeldung sowie mit der Abwicklung aller damit verbundenen Angelegenheiten vor dem US-Patent- und Markenamt: (Name(n) und Registrationsnummer(n) auflisten)

POWER OF ATTORNEY: As a named inventor, I hereby appoint the following attorney(s) and/or agent(s) to prosecute this application and transact all business in the Patent and Trademark Office connected therewith: (list name and registration number)

And I hereby appoint
Customer No. _____

Telefongespräche bitte richten an:
(Name und Telefonnummer)

Direct Telephone Calls to: (name and telephone number)

Ext. _____

Postanschrift:

Send Correspondence to:

Harrington & Smith, LLP
4 Research Drive Shelton, Connecticut 06484-6212 UNITED STATES OF AMERICA
Telephone: +1 203 925 9400 and Facsimile +1 203 944 0245
or
Customer No. _____

Voller Name des einzigen oder ursprünglichen Erfinders:		Full name of sole or first inventor:	
Juergen Michel		Juergen Michel	
Unterschrift des Erfinders	Datum	Inventor's signature	Date
Wohnsitz		Residence	
München, GERMANY		München, GERMANY	
Staatsangehörigkeit		Citizenship	
DE		DE	
Postanschrift		Post Office Address	
Hadorfer Str. 8		Hadorfer Str. 8	
81475 München		81475 München	
GERMANY		GERMANY	
Voller Name des zweiten Miterfinders (falls zutreffend):		Full name of second joint inventor, if any:	
Klaus Ingemann Pedersen		Klaus Ingemann Pedersen	
Unterschrift des Erfinders	Datum	Inventor's signature	Date
Wohnsitz		Residence	
Aalborg, DENMARK		Aalborg, DENMARK	
Staatsangehörigkeit		Citizenship	
DK		DK	
Postanschrift		Post Office Address	
Laesogade 9, 3 th		Laesogade 9, 3 th	
9000 Aalborg		9000 Aalborg	
DENMARK		DENMARK	

(Bitte entsprechende Informationen und Unterschriften im Falle von dritten und weiteren Miterfindern angeben).

(Supply similar information and signature for third and subsequent joint inventors).

Voller Name des dritten Miterfinders: Claudio Rosa		Full name of third joint inventor: Claudio Rosa	
Unterschrift des Erfinders	Datum	Inventor's signature <i>Claudio Rosa</i>	Date 11/01 '10
Wohnsitz Randers, DENMARK		Residence Randers, DENMARK	
Staatsangehörigkeit IT		Citizenship IT	
Postanschrift Krebsen 14		Post Office Address Krebsen 14	
8900 Randers		8900 Randers	
DENMARK		DENMARK	
Voller Name des vierten Miterfinders:		Full name of fourth joint inventor:	
Unterschrift des Erfinders	Datum	Inventor's signature	Date
Wohnsitz		Residence	
Staatsangehörigkeit		Citizenship	
Postanschrift		Post Office Address	
Voller Name des fünften Miterfinders:		Full name of fifth joint inventor:	
Unterschrift des Erfinders	Datum	Inventor's signature	Date
Wohnsitz		Residence	
Staatsangehörigkeit		Citizenship	
Postanschrift		Post Office Address	
Voller Name des sechsten Miterfinders:		Full name of sixth joint inventor:	
Unterschrift des Erfinders	Datum	Inventor's signature	Date
Wohnsitz		Residence	
Staatsangehörigkeit		Citizenship	
Postanschrift		Post Office Address	

(Bitte entsprechende Informationen und Unterschriften im Falle von dritten und weiteren Miterfindern angeben). (Supply similar information and signature for third and subsequent joint inventors).

IN THE UNITED STATES PATENT AND TRADEMARK OFFICE

In re U.S. Patent Application of:

APPLICANT: Juergen Michel et al.

SERIAL NO.: 12/665,427

IA FILING DATE: 06/23/2008

INTERNATIONAL APPLICATION NO.: PCT/FI2008/050384

TITLE: POWER HEADROOM REPORTING METHOD

ATTORNEY DOCKET NO.: 863.0156.U1(US)

Confirmation No.: 1011

Certificate of Mailing

I hereby certify that the following correspondence:

Transmittal Letter to US Designated/Elected Office
Declaration and Power of Attorney (12 pages)

(authorization to charge deposit account \$130.00)

Is being deposited with the United States Postal Service, on the date shown below, first class mail, in an envelope addressed to: Commissioner for Patents, P.O. Box 1450, Alexandria, VA 22313-1450, Mail Stop PCT

1/19/2010
Date

Lisa Mrozek
Lisa Mrozek



UNITED STATES PATENT AND TRADEMARK OFFICE

UNITED STATES DEPARTMENT OF COMMERCE
United States Patent and Trademark Office
Address: COMMISSIONER FOR PATENTS
P.O. Box 1450
Alexandria, Virginia 22313-1450
www.uspto.gov

Table with 3 columns: U.S. APPLICATION NUMBER NO., FIRST NAMED APPLICANT, ATTY. DOCKET NO.
29683
HARRINGTON & SMITH
4 RESEARCH DRIVE, Suite 202
SHELTON, CT 06484-6212
12/665,427
Juergen Michel
863.0156.U1(US)
INTERNATIONAL APPLICATION NO.
PCT/FI08/50384
I.A. FILING DATE
06/23/2008
PRIORITY DATE
06/20/2007

CONFIRMATION NO. 1011
371 ACCEPTANCE LETTER



Date Mailed: 04/01/2010

NOTICE OF ACCEPTANCE OF APPLICATION UNDER 35 U.S.C 371 AND 37 CFR 1.495

The applicant is hereby advised that the United States Patent and Trademark Office in its capacity as a Designated / Elected Office (37 CFR 1.495), has determined that the above identified international application has met the requirements of 35 U.S.C. 371, and is ACCEPTED for national patentability examination in the United States Patent and Trademark Office.

The United States Application Number assigned to the application is shown above and the relevant dates are:

01/22/2010 DATE OF RECEIPT OF 35 U.S.C. 371(c)(1), (c)(2) and (c)(4) REQUIREMENTS
01/22/2010 DATE OF COMPLETION OF ALL 35 U.S.C. 371 REQUIREMENTS

A Filing Receipt (PTO-103X) will be issued for the present application in due course. THE DATE APPEARING ON THE FILING RECEIPT AS THE " FILING DATE" IS THE DATE ON WHICH THE LAST OF THE 35 U.S.C. 371 (c)(1), (c)(2) and (c)(4) REQUIREMENTS HAS BEEN RECEIVED IN THE OFFICE. THIS DATE IS SHOWN ABOVE. The filing date of the above identified application is the international filing date of the international application (Article 11(3) and 35 U.S.C. 363). Once the Filing Receipt has been received, send all correspondence to the Group Art Unit designated thereon.

The following items have been received:

- Copy of the International Application filed on 12/18/2009
• Copy of the International Search Report filed on 12/18/2009
• Preliminary Amendments filed on 12/18/2009
• Information Disclosure Statements filed on 12/18/2009
• Oath or Declaration filed on 01/22/2010
• U.S. Basic National Fees filed on 12/18/2009
• Priority Documents filed on 12/18/2009

Applicant is reminded that any communications to the United States Patent and Trademark Office must be mailed to the address given in the heading and include the U.S. application no. shown above (37 CFR 1.5)

VALERIE D KINARD

Telephone: (703) 756-1432



UNITED STATES PATENT AND TRADEMARK OFFICE

UNITED STATES DEPARTMENT OF COMMERCE
United States Patent and Trademark Office
Address: COMMISSIONER FOR PATENTS
P.O. Box 1450
Alexandria, Virginia 22313-1450
www.uspto.gov

Table with 7 columns: APPLICATION NUMBER, FILING or 371(c) DATE, GRP ART UNIT, FIL FEE REC'D, ATTY. DOCKET NO, TOT CLAIMS, IND CLAIMS. Row 1: 12/665,427, 01/22/2010, 2758, 863.0156.U1(US), 39, 6

CONFIRMATION NO. 1011

FILING RECEIPT

29683
HARRINGTON & SMITH
4 RESEARCH DRIVE, Suite 202
SHELTON, CT 06484-6212



Date Mailed: 04/01/2010

Receipt is acknowledged of this non-provisional patent application. The application will be taken up for examination in due course. Applicant will be notified as to the results of the examination. Any correspondence concerning the application must include the following identification information: the U.S. APPLICATION NUMBER, FILING DATE, NAME OF APPLICANT, and TITLE OF INVENTION. Fees transmitted by check or draft are subject to collection. Please verify the accuracy of the data presented on this receipt. If an error is noted on this Filing Receipt, please submit a written request for a Filing Receipt Correction. Please provide a copy of this Filing Receipt with the changes noted thereon. If you received a "Notice to File Missing Parts" for this application, please submit any corrections to this Filing Receipt with your reply to the Notice. When the USPTO processes the reply to the Notice, the USPTO will generate another Filing Receipt incorporating the requested corrections

Applicant(s)

Juergen Michel, Munchen, GERMANY;
Klaus Ingemann Pedersen, Aalborg, DENMARK;
Claudio Rosa, Randers, DENMARK;

Power of Attorney: The patent practitioners associated with Customer Number 29683

Domestic Priority data as claimed by applicant

This application is a 371 of PCT/FI08/50384 06/23/2008
which claims benefit of 60/936,649 06/20/2007

Foreign Applications

If Required, Foreign Filing License Granted: 03/30/2010

The country code and number of your priority application, to be used for filing abroad under the Paris Convention, is US 12/665,427

Projected Publication Date: 07/08/2010

Non-Publication Request: No

Early Publication Request: No

Title

Power Headroom Reporting Method

Preliminary Class

PROTECTING YOUR INVENTION OUTSIDE THE UNITED STATES

Since the rights granted by a U.S. patent extend only throughout the territory of the United States and have no effect in a foreign country, an inventor who wishes patent protection in another country must apply for a patent in a specific country or in regional patent offices. Applicants may wish to consider the filing of an international application under the Patent Cooperation Treaty (PCT). An international (PCT) application generally has the same effect as a regular national patent application in each PCT-member country. The PCT process **simplifies** the filing of patent applications on the same invention in member countries, but **does not result** in a grant of "an international patent" and does not eliminate the need of applicants to file additional documents and fees in countries where patent protection is desired.

Almost every country has its own patent law, and a person desiring a patent in a particular country must make an application for patent in that country in accordance with its particular laws. Since the laws of many countries differ in various respects from the patent law of the United States, applicants are advised to seek guidance from specific foreign countries to ensure that patent rights are not lost prematurely.

Applicants also are advised that in the case of inventions made in the United States, the Director of the USPTO must issue a license before applicants can apply for a patent in a foreign country. The filing of a U.S. patent application serves as a request for a foreign filing license. The application's filing receipt contains further information and guidance as to the status of applicant's license for foreign filing.

Applicants may wish to consult the USPTO booklet, "General Information Concerning Patents" (specifically, the section entitled "Treaties and Foreign Patents") for more information on timeframes and deadlines for filing foreign patent applications. The guide is available either by contacting the USPTO Contact Center at 800-786-9199, or it can be viewed on the USPTO website at <http://www.uspto.gov/web/offices/pac/doc/general/index.html>.

For information on preventing theft of your intellectual property (patents, trademarks and copyrights), you may wish to consult the U.S. Government website, <http://www.stopfakes.gov>. Part of a Department of Commerce initiative, this website includes self-help "toolkits" giving innovators guidance on how to protect intellectual property in specific countries such as China, Korea and Mexico. For questions regarding patent enforcement issues, applicants may call the U.S. Government hotline at 1-866-999-HALT (1-866-999-4158).

LICENSE FOR FOREIGN FILING UNDER

Title 35, United States Code, Section 184

Title 37, Code of Federal Regulations, 5.11 & 5.15

GRANTED

The applicant has been granted a license under 35 U.S.C. 184, if the phrase "IF REQUIRED, FOREIGN FILING LICENSE GRANTED" followed by a date appears on this form. Such licenses are issued in all applications where the conditions for issuance of a license have been met, regardless of whether or not a license may be required as set forth in 37 CFR 5.15. The scope and limitations of this license are set forth in 37 CFR 5.15(a) unless an earlier

license has been issued under 37 CFR 5.15(b). The license is subject to revocation upon written notification. The date indicated is the effective date of the license, unless an earlier license of similar scope has been granted under 37 CFR 5.13 or 5.14.

This license is to be retained by the licensee and may be used at any time on or after the effective date thereof unless it is revoked. This license is automatically transferred to any related applications(s) filed under 37 CFR 1.53(d). This license is not retroactive.

The grant of a license does not in any way lessen the responsibility of a licensee for the security of the subject matter as imposed by any Government contract or the provisions of existing laws relating to espionage and the national security or the export of technical data. Licensees should apprise themselves of current regulations especially with respect to certain countries, of other agencies, particularly the Office of Defense Trade Controls, Department of State (with respect to Arms, Munitions and Implements of War (22 CFR 121-128)); the Bureau of Industry and Security, Department of Commerce (15 CFR parts 730-774); the Office of Foreign Assets Control, Department of Treasury (31 CFR Parts 500+) and the Department of Energy.

NOT GRANTED

No license under 35 U.S.C. 184 has been granted at this time, if the phrase "IF REQUIRED, FOREIGN FILING LICENSE GRANTED" DOES NOT appear on this form. Applicant may still petition for a license under 37 CFR 5.12, if a license is desired before the expiration of 6 months from the filing date of the application. If 6 months has lapsed from the filing date of this application and the licensee has not received any indication of a secrecy order under 35 U.S.C. 181, the licensee may foreign file the application pursuant to 37 CFR 5.15(b).

MULTIPLE DEPENDENT CLAIM
 FEE CALCULATION SHEET
 (FOR USE WITH FORM PTO-875)

SERIAL NO.

12665427

FILING DATE

12-18-09

APPLICANT(S)

CLAIMS

	AS FILED		AFTER 1 st AMENDMENT		AFTER 2 nd AMENDMENT	
	IND.	DEP.	IND.	DEP.	IND.	DEP.
1	/		/			
2		/		/		
3		/		/		
4		/		/		
5		/		/		
6		/		/		
7		/		/		
8		/		/		
9		/		/		
10		/		/		
11		/		/		
12	/		/			
13		/		/		
14		/		/		
15		/		/		
16		/		/		
17		/		/		
18		/		/		
19		/		/		
20	/		/			
21		/		/		
22		/		/		
23		/		/		
24		/		/		
25		/		/		
26		/		/		
27		/		/		
28	/		/			
29		/		/		
30		/		/		
31		/		/		
32		/		/		
33		/		/		
34		/	/			
35		/		/		
36		/		/		
37	/		/			
38		/		/		
39		/		/		
40						
41						
42						
43						
44						
45						
46						
47						
48						
49						
50						
TOTAL IND.		↓	6	↓		↓
TOTAL DEP.		←	33	←		←
TOTAL CLAIMS			39			

	AS FILED		AFTER 1 st AMENDMENT		AFTER 2 nd AMENDMENT	
	IND.	DEP.	IND.	DEP.	IND.	DEP.
51						
52						
53						
54						
55						
56						
57						
58						
59						
60						
61						
62						
63						
64						
65						
66						
67						
68						
69						
70						
71						
72						
73						
74						
75						
76						
77						
78						
79						
80						
81						
82						
83						
84						
85						
86						
87						
88						
89						
90						
91						
92						
93						
94						
95						
96						
97						
98						
99						
100						
TOTAL IND.		↓		↓		↓
TOTAL DEP.		←		←		←
TOTAL CLAIMS						

PATENT APPLICATION FEE DETERMINATION RECORD

Effective December 8, 2004

Application or Docket Number

12/665427

CLAIMS AS FILED - PART I

	(Column 1)	(Column 2)
U.S. NATIONAL STAGE FEES		
BASIC FEE	SMALL ENT. = \$ 150	LARGE ENT. = \$ 300
EXAMINATION FEE	Satisfies PCT Article 33(1)-(4) = \$ 50 / \$ 100	All other situations = \$ 100 / \$ 200
SEARCH FEE	U.S. is ISA = \$ 50 / \$ 100 ALL other countries = \$ 200 / \$ 400	ALL other situations = \$ 250 / \$ 500
FEE FOR EXTRA SPEC. PGS.	minus 100 =	/ 50 =
TOTAL CHARGEABLE CLAIMS	39 minus 20 = *	19
INDEPENDENT CLAIMS	6 minus 3 = *	3
MULTIPLE DEPENDENT CLAIM PRESENT	<input type="checkbox"/>	

SMALL ENTITY TYPE

OR

OTHER THAN SMALL ENTITY

RATE	FEE		RATE	FEE
BASIC FEE		OR	BASIC FEE	330
EXAM. FEE			EXAM. FEE	220
SEARCH FEE			SEARCH FEE	430
X \$ 125 =			X \$ 250 =	
X \$ 25 =		OR	X \$ 50 =	988
X \$ 100 =		OR	X \$ 200 =	660
+ \$ 180 =		OR	+ \$ 360 =	
TOTAL		OR	TOTAL	2628

* If the difference in column 1 is less than zero, enter "0" in column 2

CLAIMS AS AMENDED - PART II

	(Column 1)	(Column 2)	(Column 3)
AMENDMENT A	CLAIMS REMAINING AFTER AMENDMENT	HIGHEST NUMBER PREVIOUSLY PAID FOR	PRESENT EXTRA
Total	*	Minus **	=
Independent	*	Minus ***	=
FIRST PRESENTATION OF MULTIPLE DEPENDENT CLAIM <input type="checkbox"/>			

SMALL ENTITY

OR

OTHER THAN SMALL ENTITY

RATE	ADDITIONAL FEE		RATE	ADDITIONAL FEE
X \$ 25 =		OR	X \$ 50 =	
X \$ 100 =		OR	X \$ 200 =	
+ \$ 180 =		OR	+ \$ 360 =	
TOTAL ADDIT. FEE		OR	TOTAL ADDIT. FEE	

	(Column 1)	(Column 2)	(Column 3)
AMENDMENT B	CLAIMS REMAINING AFTER AMENDMENT	HIGHEST NUMBER PREVIOUSLY PAID FOR	PRESENT EXTRA
Total	*	Minus **	=
Independent	*	Minus ***	=
FIRST PRESENTATION OF MULTIPLE DEPENDENT CLAIM <input type="checkbox"/>			

RATE	ADDITIONAL FEE		RATE	ADDITIONAL FEE
X \$ 25 =		OR	X \$ 50 =	
X \$ 100 =		OR	X \$ 200 =	
+ \$ 180 =		OR	+ \$ 360 =	
TOTAL ADDIT. FEE		OR	TOTAL ADDIT. FEE	

* If the entry in column 1 is less than the entry in column 2, write "0" in column 3.

** If the "Highest Number Previously Paid For" IN THIS SPACE is less than '20', enter "20".

*** If the "Highest Number Previously Paid For" IN THIS SPACE is less than '3', enter "3".

The "Highest Number Previously Paid For" (Total or Independent) is the highest number found in the appropriate box in column 1.



UNITED STATES PATENT AND TRADEMARK OFFICE

UNITED STATES DEPARTMENT OF COMMERCE
United States Patent and Trademark Office
Address: COMMISSIONER FOR PATENTS
P.O. Box 1450
Alexandria, Virginia 22313-1450
www.uspto.gov

APPLICATION NUMBER	FILING OR 371(C) DATE	FIRST NAMED APPLICANT	ATTY. DOCKET NO./TITLE
12/665,427	01/22/2010	Juergen Michel	863.0156.U1(US)

CONFIRMATION NO. 1011

29683
HARRINGTON & SMITH
4 RESEARCH DRIVE, Suite 202
SHELTON, CT 06484-6212

PUBLICATION NOTICE



Title:Power Headroom Reporting Method

Publication No.US-2010-0173665-A1

Publication Date:07/08/2010

NOTICE OF PUBLICATION OF APPLICATION

The above-identified application will be electronically published as a patent application publication pursuant to 37 CFR 1.211, et seq. The patent application publication number and publication date are set forth above.

The publication may be accessed through the USPTO's publically available Searchable Databases via the Internet at www.uspto.gov. The direct link to access the publication is currently <http://www.uspto.gov/patft/>.

The publication process established by the Office does not provide for mailing a copy of the publication to applicant. A copy of the publication may be obtained from the Office upon payment of the appropriate fee set forth in 37 CFR 1.19(a)(1). Orders for copies of patent application publications are handled by the USPTO's Office of Public Records. The Office of Public Records can be reached by telephone at (703) 308-9726 or (800) 972-6382, by facsimile at (703) 305-8759, by mail addressed to the United States Patent and Trademark Office, Office of Public Records, Alexandria, VA 22313-1450 or via the Internet.

In addition, information on the status of the application, including the mailing date of Office actions and the dates of receipt of correspondence filed in the Office, may also be accessed via the Internet through the Patent Electronic Business Center at www.uspto.gov using the public side of the Patent Application Information and Retrieval (PAIR) system. The direct link to access this status information is currently <http://pair.uspto.gov/>. Prior to publication, such status information is confidential and may only be obtained by applicant using the private side of PAIR.

Further assistance in electronically accessing the publication, or about PAIR, is available by calling the Patent Electronic Business Center at 1-866-217-9197.

Office of Data Management, Application Assistance Unit (571) 272-4000, or (571) 272-4200, or 1-888-786-0101



UNITED STATES PATENT AND TRADEMARK OFFICE

UNITED STATES DEPARTMENT OF COMMERCE
United States Patent and Trademark Office
Address: COMMISSIONER FOR PATENTS
P.O. Box 1450
Alexandria, Virginia 22313-1450
www.uspto.gov

APPLICATION NO.	FILING DATE	FIRST NAMED INVENTOR	ATTORNEY DOCKET NO.	CONFIRMATION NO.
12/665,427	01/22/2010	Juergen Michel	863.0156.U1(US)	1011
29683	7590	03/22/2012	EXAMINER	
HARRINGTON & SMITH 4 RESEARCH DRIVE, Suite 202 SHELTON, CT 06484-6212			REGO, DOMINIC E	
			ART UNIT	PAPER NUMBER
			2618	
			MAIL DATE	DELIVERY MODE
			03/22/2012	PAPER

Please find below and/or attached an Office communication concerning this application or proceeding.

The time period for reply, if any, is set in the attached communication.

DETAILED ACTION

Claim Rejections - 35 USC § 101

1. 35 U.S.C. 101 reads as follows:

Whoever invents or discovers any new and useful process, machine, manufacture, or composition of matter, or any new and useful improvement thereof, may obtain a patent therefor, subject to the conditions and requirements of this title.

Claims 28-33 are rejected under 35 U.S.C. 101 because the claimed invention is directed to non-statutory subject matter. In the specification, paragraph 0035, recites " A memory may comprise any known type of data storage and/or transmission media, including magnetic media, optical media, random access memory (RAM), read-only memory (ROM), a data cache, a data object, etc. Moreover, similar to the CPU, the memory may reside at a single physical location, comprising one or more types of data storage, or be distributed across a plurality of physical systems in various forms ".

Based on underlying parts "transmission media", treating claims 28-33 as a whole, it is effectively claiming a signal. Signal does not within any of the statutory categories, thus, not statutory (See MPEP 2100, In re Nuijten, Docket no. 2006-1371 (Fed. Cir. Sept 20, 2007)(slip. Op. at 18)). Based on the latest 101 guideline, claims 28-33 can be amended to overcome the 101 by adding the term "Non-transitory". For example, claims 28-33 can be recited as "A non-transitory computer program product.....".

Specification objection

2. The specification is objected to as failing to provide proper antecedent basis for the claimed subject matter. See 37 CFR 1.75(d)(1) and MPEP § 608.01(o). Correction of the following is required: Regarding claims 28-33, Applicant recites limitations “A computer program product” is not disclosed in the Specification. In the specification, paragraph 0035, stated “The computer system of this embodiment includes a CPU processor, comprising..... or A memory may comprise any known type of data storage.....” which is not same as "a computer program product". Therefore, the specification does not provide enough antecedent basis to the above claims.

Claim Rejections - 35 USC § 102

3. The following is a quotation of the appropriate paragraphs of 35 U.S.C. 102 that form the basis for the rejections under this section made in this Office action:

A person shall be entitled to a patent unless –

(e) the invention was described in (1) an application for patent, published under section 122(b), by another filed in the United States before the invention by the applicant for patent or (2) a patent granted on an application for patent by another filed in the United States before the invention by the applicant for patent, except that an international application filed under the treaty defined in section 351(a) shall have the effects for purposes of this subsection of an application filed in the United States only if the international application designated the United States and was published under Article 21(2) of such treaty in the English language.

4. Claims 1,2,4,5,12,13,15,16,20,21,23,24,28,29,31,32,34, and 37 are rejected under 35 U.S.C. 102(e) as being anticipated by Malladi et al. (US 2007/0270175).

Regarding claim 1, Malladi teaches a method comprising: determining that a set of at least one triggering criterion is met; and providing a power control headroom report on an uplink from user equipment, in response to determining that the set is met, wherein said at least one triggering criterion include a threshold having been reached (Paragraph 0034).

Regarding claim 2, Malladi teaches the method of claim 1, wherein said threshold is adjustable via a signal to the user equipment (Paragraph 0025, 0030, and 0097).

Regarding claim 4, Malladi teaches the method of claim 1, wherein said set of at least one triggering criterion include any one of a plurality of criteria that each entail Teaching a respective threshold (Paragraph 0025, 0030, and 0097).

Regarding claim 5, Malladi teaches the method of claim 4, wherein the plurality of criteria comprise a first criterion, a second criterion, and a third criterion (Paragraph 0025, 0030, and 0097. Also, it's inherent).

Regarding claim 12, Malladi teaches an apparatus comprising: means for determining that a set of at least one triggering criterion is met; and means for providing a power control headroom report on an uplink from user equipment, in response to the set having been met, wherein said at least one triggering criterion include a threshold having been reached (Paragraph 0034).

Regarding claim 13, Malladi teaches the apparatus of claim 12, wherein said threshold is adjustable via a signal to the user equipment (Paragraph 0025, 0030, and 0097).

Regarding claim 15, Malladi teaches the apparatus of claim 12, wherein said set of at least one triggering criterion include any one of a plurality of criteria that each entail reaching a respective threshold (Paragraph 0025, 0030, and 0097).

Regarding claim 16, Malladi teaches the apparatus of claim 15, wherein the plurality of criteria comprise a first criterion, a second criterion, and a third criterion (Paragraph 0025, 0030, and 0097. Also, it's inherent).

Regarding claim 20, Malladi teaches apparatus comprising: a triggering module configured to determine that a set of at least one triggering criterion is met; and a transceiver configured to provide a power control headroom report on an uplink from said user equipment, in response to the set having been met, wherein said at least one triggering criterion include a threshold having been reached (Paragraph 0034).

Regarding claim 21, Malladi teaches the apparatus of claim 20, wherein said threshold is adjustable via a signal to the apparatus (Paragraph 0025, 0030, and 0097).

Regarding claim 23, Malladi teaches the apparatus of claim 20, wherein said set of at least one triggering criterion include any one of a plurality of criteria that each entail reaching a respective threshold (Paragraph 0025, 0030, and 0097).

Regarding claim 24, Malladi teaches the apparatus of claim 23, wherein the plurality of criteria comprise a first criterion, a second criterion, and a third criterion (Paragraph 0025, 0030, and 0097. Also, it's inherent).

Regarding claim 28, Malladi teaches a computer program product comprising a computer readable medium having executable code stored therein; the code, when executed by a processor, adapted to carry out the functions of: determining that a set of

at least one triggering criterion is met; and providing a power control headroom report on an uplink from user equipment, in response to the set having been met, wherein said at least one triggering criterion include a threshold having been reached (Paragraph 0034).

Regarding claim 29, Malladi teaches the computer program product of claim 28, wherein said threshold is adjustable via a signal to the user equipment (Paragraph 0025, 0030, and 0097).

Regarding claim 31, Malladi teaches the computer program product of claim 28, wherein said set of at least one triggering criterion include any one of a plurality of criteria that each entail reaching a respective threshold (Paragraph 0025, 0030, and 0097).

Regarding claim 32, Malladi teaches the computer program product of claim 31, wherein the plurality of criteria comprise a first criterion, a second criterion, and a third criterion (Paragraph 0025, 0030, and 0097. Also, it's inherent).

Regarding claim 34, Malladi teaches a network element comprising: a report receiving module configured to receive a power control headroom report on an uplink from user equipment, in response to the user equipment determining that a set of at least one triggering criterion is met because a threshold has been reached, and a threshold adjustment module, configured to provide a threshold adjustment signal to the user equipment in order to adjust the threshold (Paragraph 0034).

Regarding claim 37, Malladi teaches a system comprising: user equipment having a triggering module configured to determine that a set of at least one triggering

criterion is met, and having a transceiver configured to provide a power control headroom report on an uplink from said user equipment, in response to the set having been met, wherein said at least one triggering criterion include a threshold having been reached (Paragraph 0034); and

a network element having a report receiving module configured to receive a power control headroom report on an uplink from user equipment, in response to the user equipment determining that a set of at least one triggering criterion is met because said threshold has been reached, and having a threshold adjustment module configured to provide a threshold adjustment signal to the user equipment in order to adjust the threshold (Paragraph 0025, 0030, 0034, and 0097).

Claim Rejections - 35 USC § 103

5. The following is a quotation of 35 U.S.C. 103(a) which forms the basis for all obviousness rejections set forth in this Office action:

(a) A patent may not be obtained though the invention is not identically disclosed or described as set forth in section 102 of this title, if the differences between the subject matter sought to be patented and the prior art are such that the subject matter as a whole would have been obvious at the time the invention was made to a person having ordinary skill in the art to which said subject matter pertains. Patentability shall not be negatived by the manner in which the invention was made.

6. Claims 3, 14, 22, 30, 35, and 38 are rejected under 35 U.S.C. 103(a) as being unpatentable over Malladi et al. (US 2007/0270175) in view of Malladi et al. (US 2010/0029212).

Regarding claim 3, Malladi *175 fails to teach the method of claim 1, wherein

the set comprises a criterion such that an absolute difference between current and most recent path-loss measurements has reached a threshold of difference.

However, in related art, Malladi *212 teaches the method of claim 1, wherein the set comprises a criterion such that an absolute difference between current and most recent path-loss measurements has reached a threshold of difference (Paragraphs 0018, 0078, 0079, 0081). Therefore, it would have been obvious to one of ordinary skill in the art at the time of the invention to provide the above teaching of Malladi *212 to Malladi *175 in order to mitigate interference and maximize data and voice communication.

Regarding claim 14, Malladi*175 fails to teach the apparatus of claim 12, wherein the set comprises a criterion such that an absolute difference between current and most recent path-loss measurements has reached a threshold of difference.

However, in related art, Malladi *212 teaches the apparatus of claim 12, wherein the set comprises a criterion such that an absolute difference between current and most recent path-loss measurements has reached a threshold of difference (Paragraphs 0018, 0078, 0079, 0081). Therefore, it would have been obvious to one of ordinary skill in the art at the time of the invention to provide the above teaching of Malladi *212 to Malladi *175 in order to mitigate interference and maximize data and voice communication.

Regarding claim 22, Malladi*175 fails to teach the apparatus of claim 20, wherein the set comprises a criterion such that an absolute difference between current and most recent path-loss measurements has reached a threshold of difference.

However, in related art, Malladi *212 teaches the apparatus of claim 20, wherein the set comprises a criterion such that an absolute difference between current and most recent path-loss measurements has reached a threshold of difference (Paragraphs 0018, 0078, 0079, 0081). Therefore, it would have been obvious to one of ordinary skill in the art at the time of the invention to provide the above teaching of Malladi *212 to Malladi *175 in order to mitigate interference and maximize data and voice communication.

Regarding claim 30, Malladi*175 fails to teach the computer program product of claim 28, wherein the set comprises a criterion such that an absolute difference between current and most recent path-loss measurements has reached a threshold of difference.

However, in related art, Malladi *212 teaches the apparatus of claim 20, wherein the set comprises a criterion such that an absolute difference between current and most recent path-loss measurements has reached a threshold of difference (Paragraphs 0018, 0078, 0079, 0081). Therefore, it would have been obvious to one of ordinary skill in the art at the time of the invention to provide the above teaching of Malladi *212 to Malladi *175 in order to mitigate interference and maximize data and voice communication.

Regarding claim 35, Malladi*175 fails to teach the network element of claim 34, wherein the set comprises a criterion such that an absolute difference between current and most recent path-loss measurements has reached a threshold of difference.

However, in related art, Malladi *212 teaches the network element of claim 34,

wherein the set comprises a criterion such that an absolute difference between current and most recent path-loss measurements has reached a threshold of difference (Paragraphs 0018, 0078, 0079, 0081). Therefore, it would have been obvious to one of ordinary skill in the art at the time of the invention to provide the above teaching of Malladi *212 to Malladi *175 in order to mitigate interference and maximize data and voice communication.

Regarding claim 38, Malladi*175 fails to teach the system of claim 37, wherein the set comprises a criterion such that an absolute difference between current and most recent path-loss measurements has reached a threshold of difference.

However, in related art, Malladi *212 teaches the system of claim 37, wherein the set comprises a criterion such that an absolute difference between current and most recent path-loss measurements has reached a threshold of difference (Paragraphs 0018, 0078, 0079, 0081). Therefore, it would have been obvious to one of ordinary skill in the art at the time of the invention to provide the above teaching of Malladi *212 to Malladi *175 in order to mitigate interference and maximize data and voice communication.

7. Claims 6 and 36 are rejected under 35 U.S.C. 103(a) as being unpatentable over Malladi et al. (US 2007/0270175) in view of Johnson et al. (US 2008/0240013).

Regarding claim 6, Malladi fails to teach the method of claim 1, wherein the set comprises a criterion such that a number of received closed loop power corrections has reached a threshold of corrections.

However, in related art, Johnson teaches the method of claim 1, wherein the set comprises a criterion such that a number of received closed loop power corrections has reached a threshold of corrections (Paragraph 0024). Therefore, it would have been obvious to one of ordinary skill in the art at the time of the invention to provide the above teaching of Johnson to Malladi in order to utilize and assign the available RF resources efficiently.

Regarding claim 36, Malladi fails to teach the network element of claim 34, further comprising a correction module configured to provide a closed loop power control correction command signal to the user equipment at least partly in response to said power control headroom report.

However, in related art, Johnson teaches the network element of claim 34, further comprising a correction module configured to provide a closed loop power control correction command signal to the user equipment at least partly in response to said power control headroom report (Paragraph 0024). Therefore, it would have been obvious to one of ordinary skill in the art at the time of the invention to provide the above teaching of Johnson to Malladi in order to utilize and assign the available RF resources efficiently.

8. Claim 7 is rejected under 35 U.S.C. 103(a) as being unpatentable over Malladi et al. (US 2007/0270175) in view of Damnjanovic et al. (US 2008/0247358).

Regarding claim 7, Malladi fails to teach the method of claim 1, wherein the set

comprises a criterion such that an amount of transmission time intervals, following an open loop power control modification, has reached a threshold of intervals since modification.

However, in related art, Damnjanovic teaches the method of claim 1, wherein the set comprises a criterion such that an amount of transmission time intervals, following an open loop power control modification, has reached a threshold of intervals since modification (Paragraph 076). Therefore, it would have been obvious to one of ordinary skill in the art at the time of the invention to provide the above teaching of Damnjanovic to Malladi in order to ensure that every UE in the system receives throughput properly.

9. Claim 8 is rejected under 35 U.S.C. 103(a) as being unpatentable over Malladi et al. (US 2007/0270175) in view of Yavuz et al. (US 2009/0034474).

Regarding claim 8, Malladi fails to teach the method of claim 1, wherein the set comprises a criterion such that an amount of transmission time intervals, following a previous power control headroom report, has reached a threshold of intervals since reporting.

However, in related art, Yavuz teaches the method of claim 1, wherein the set comprises a criterion such that an amount of transmission time intervals, following a previous power control headroom report, has reached a threshold of intervals since reporting (See Abstract; Paragraphs 0018, 0062, 0068, 0073). Therefore, it would have been obvious to one of ordinary skill in the art at the time of the invention to provide the

above teaching of Yavuz to Malladi in order to provide increased data throughput and lower power consumption.

10. Claims 9, 17, 25, 33, and 39 are rejected under 35 U.S.C. 103(a) as being unpatentable over Malladi et al. (US 2007/0270175) in view of Johnson et al. (US 2008/0240013), and further in view of Damnjanovic et al. (US 2008/0247358).

Regarding claim 9, Malladi fails to teach the method of claim 5, wherein the first criterion is such that a number of received closed loop power corrections has reached a threshold of corrections, and wherein the second criterion is such that an amount of transmission time intervals, following an open loop power control modification, has reached a threshold of intervals since modification.

However, in related art, Johnson teaches the method of claim 5, wherein the first criterion is such that a number of received closed loop power corrections has reached a threshold of corrections (Paragraph 0024). Therefore, it would have been obvious to one of ordinary skill in the art at the time of the invention to provide the above teaching of Johnson to Malladi in order to utilize and assign the available RF resources efficiently.

The combination of Malladi and Johnson fail to teach wherein the second criterion is such that an amount of transmission time intervals, following an open loop power control modification, has reached a threshold of intervals since modification.

However, in related art, Damnjanovic teaches wherein the second criterion is such that an amount of transmission time intervals, following an open loop power control modification, has reached a threshold of intervals since modification (Paragraph 076). Therefore, it would have been obvious to one of ordinary skill in the art at the time of the invention to provide the above teaching of Damnjanovic to Malladi and Johnson in order to ensure that every UE in the system receives throughput properly.

Regarding claim 17, Malladi fails to teach the apparatus of claim 16, wherein the first criterion is such that a number of received closed loop power corrections has reached a threshold of corrections, and wherein the second criterion is such that an amount of transmission time intervals, following an open loop power control modification, has reached a threshold of intervals since modification.

However, in related art, Johnson teaches the apparatus of claim 16, wherein the first criterion is such that a number of received closed loop power corrections has reached a threshold of corrections (Paragraph 0024). Therefore, it would have been obvious to one of ordinary skill in the art at the time of the invention to provide the above teaching of Johnson to Malladi in order to utilize and assign the available RF resources efficiently.

The combination of Malladi and Johnson fail to teach wherein the second criterion is such that an amount of transmission time intervals, following an open loop power control modification, has reached a threshold of intervals since modification.

However, in related art, Damnjanovic teaches wherein the second criterion is such that an amount of transmission time intervals, following an open loop power

control modification, has reached a threshold of intervals since modification (Paragraph 076). Therefore, it would have been obvious to one of ordinary skill in the art at the time of the invention to provide the above teaching of Damnjanovic to Malladi and Johnson in order to ensure that every UE in the system receives throughput properly.

Regarding claim 25, Malladi fails to teach the apparatus of claim 24, wherein the first criterion is such that a number of received closed loop power corrections has reached a threshold of corrections, and wherein the second criterion is such that an amount of transmission time intervals, following an open loop power control modification, has reached a threshold of intervals since modification.

However, in related art, Johnson teaches the apparatus of claim 24, wherein the first criterion is such that a number of received closed loop power corrections has reached a threshold of corrections (Paragraph 0024). Therefore, it would have been obvious to one of ordinary skill in the art at the time of the invention to provide the above teaching of Johnson to Malladi in order to utilize and assign the available RF resources efficiently.

The combination of Malladi and Johnson fail to teach wherein the second criterion is such that an amount of transmission time intervals, following an open loop power control modification, has reached a threshold of intervals since modification.

However, in related art, Damnjanovic teaches wherein the second criterion is such that an amount of transmission time intervals, following an open loop power control modification, has reached a threshold of intervals since modification (Paragraph 076). Therefore, it would have been obvious to one of ordinary skill in the art at the time

of the invention to provide the above teaching of Damnjanovic to Malladi and Johnson in order to ensure that every UE in the system receives throughput properly.

Regarding claim 33, Malladi fails to teach the apparatus of claim 24, wherein the first criterion is such that a number of received closed loop power corrections has reached a threshold of corrections, and wherein the second criterion is such that an amount of transmission time intervals, following an open loop power control modification, has reached a threshold of intervals since modification.

However, in related art, Johnson teaches the computer program product of claim 32, wherein the first criterion is such that a number of received closed loop power corrections has reached a threshold of corrections (Paragraph 0024). Therefore, it would have been obvious to one of ordinary skill in the art at the time of the invention to provide the above teaching of Johnson to Malladi in order to utilize and assign the available RF resources efficiently.

The combination of Malladi and Johnson fail to teach wherein the second criterion is such that an amount of transmission time intervals, following an open loop power control modification, has reached a threshold of intervals since modification.

However, in related art, Damnjanovic teaches wherein the second criterion is such that an amount of transmission time intervals, following an open loop power control modification, has reached a threshold of intervals since modification (Paragraph 076). Therefore, it would have been obvious to one of ordinary skill in the art at the time of the invention to provide the above teaching of Damnjanovic to Malladi and Johnson in order to ensure that every UE in the system receives throughput properly.

Regarding claim 39, Malladi teaches the system of claim 37, wherein the set comprises a first criterion, a second criterion, and a third criterion (Paragraph 0025, 0030, 0034, and 0097 and it's inherent), but does not specifically wherein the first criterion is such that a number of received closed loop power corrections has reached a threshold of corrections, and wherein the second criterion is such that an amount of transmission time intervals, following an open loop power control modification, has reached a threshold of intervals since modification.

However, in related art, Johnson teaches wherein the first criterion is such that a number of received closed loop power corrections has reached a threshold of corrections (Paragraph 0024). Therefore, it would have been obvious to one of ordinary skill in the art at the time of the invention to provide the above teaching of Johnson to Malladi in order to utilize and assign the available RF resources efficiently.

The combination of Malladi and Johnson fail to teach wherein the second criterion is such that an amount of transmission time intervals, following an open loop power control modification, has reached a threshold of intervals since modification.

However, in related art, Damnjanovic teaches wherein the second criterion is such that an amount of transmission time intervals, following an open loop power control modification, has reached a threshold of intervals since modification (Paragraph 076). Therefore, it would have been obvious to one of ordinary skill in the art at the time of the invention to provide the above teaching of Damnjanovic to Malladi and Johnson in order to ensure that every UE in the system receives throughput properly.

11. Claims 8, 18, and 26 are rejected under 35 U.S.C. 103(a) as being unpatentable over Malladi et al. (US 2007/0270175) in view of Johnson et al. (US 2008/0240013) in view of Damnjanovic et al. (US 2008/0247358), and further in view of Yavuz et al. (US 2009/0034474).

Regarding claim 10, the combination of Malladi, Johnson, and Damnjanovic do not specifically teach the method of claim 9, wherein the third criterion is such that an amount of transmission time intervals, following a previous power control headroom report, has reached a threshold of intervals since reporting.

However, in related art, Yavuz teaches the method of claim 9, wherein the third criterion is such that an amount of transmission time intervals, following a previous power control headroom report, has reached a threshold of intervals since reporting (See Abstract; Paragraphs 0018, 0062, 0068, 0073). Therefore, it would have been obvious to one of ordinary skill in the art at the time of the invention to provide the above teaching of Yavuz to Malladi, Johnson, and Damnjanovic in order to provide increased data throughput and lower power consumption.

Regarding claim 18, the combination of Malladi, Johnson, and Damnjanovic do not specifically teach the apparatus of claim 17, wherein the third criterion is such that an amount of transmission time intervals, following a previous power control headroom report, has reached a threshold of intervals since reporting.

However, in related art, Yavuz teaches the apparatus of claim 17, wherein the third criterion is such that an amount of transmission time intervals, following a previous

power control headroom report, has reached a threshold of intervals since reporting (See Abstract; Paragraphs 0018, 0062, 0068, 0073). Therefore, it would have been obvious to one of ordinary skill in the art at the time of the invention to provide the above teaching of Yavuz to Malladi, Johnson, and Damnjanovic in order to provide increased data throughput and lower power consumption.

Regarding claim 26, the combination of Malladi, Johnson, and Damnjanovic do not specifically teach the apparatus of claim 24, wherein the third criterion is such that an amount of transmission time intervals, following a previous power control headroom report, has reached a threshold of intervals since reporting.

However, in related art, Yavuz teaches the apparatus of claim 24, wherein the third criterion is such that an amount of transmission time intervals, following a previous power control headroom report, has reached a threshold of intervals since reporting (See Abstract; Paragraphs 0018, 0062, 0068, 0073). Therefore, it would have been obvious to one of ordinary skill in the art at the time of the invention to provide the above teaching of Yavuz to Malladi, Johnson, and Damnjanovic in order to provide increased data throughput and lower power consumption.

12. Claims 11, 19, and 27 are rejected under 35 U.S.C. 103(a) as being unpatentable over Malladi et al. (US 2007/0270175) in view of Johnson et al. (US 2008/0240013) in view of Damnjanovic et al. (US 2008/0247358), and further in view of Malladi et al. (US 2010/0029212).

Regarding claim 11, Malladi *175, Johnson, and Damnjanovic fail to teach the method of claim 9, wherein the third criterion is such that an absolute difference between current and most recent path-loss measurements has reached a threshold of difference.

However, in related art, Malladi *212 teaches the method of claim 9, wherein the third criterion is such that an absolute difference between current and most recent path-loss measurements has reached a threshold of difference (Paragraphs 0018, 0078, 0079, 0081). Therefore, it would have been obvious to one of ordinary skill in the art at the time of the invention to provide the above teaching of Malladi *212 to Malladi *175, Johnson, and Damnjanovic in order to mitigate interference and maximize data and voice communication.

Regarding claim 19, Malladi *175, Johnson, and Damnjanovic fail to teach the apparatus of claim 17, wherein the third criterion is such that an absolute difference between current and most recent path-loss measurements has reached a threshold of difference.

However, in related art, Malladi *212 teaches the apparatus of claim 17, wherein the third criterion is such that an absolute difference between current and most recent path-loss measurements has reached a threshold of difference (Paragraphs 0018, 0078, 0079, 0081). Therefore, it would have been obvious to one of ordinary skill in the art at the time of the invention to provide the above teaching of Malladi *212 to Malladi *175, Johnson, and Damnjanovic in order to mitigate interference and maximize data and voice communication.

Regarding claim 27, Malladi *175, Johnson, and Damnjanovic fail to teach the apparatus of claim 24, wherein the third criterion is such that an absolute difference between current and most recent path-loss measurements has reached a threshold of difference.

However, in related art, Malladi *212 teaches the apparatus of claim 24, wherein the third criterion is such that an absolute difference between current and most recent path-loss measurements has reached a threshold of difference (Paragraphs 0018, 0078, 0079, 0081). Therefore, it would have been obvious to one of ordinary skill in the art at the time of the invention to provide the above teaching of Malladi *212 to Malladi *175, Johnson, and Damnjanovic in order to mitigate interference and maximize data and voice communication.

Conclusion

13. The prior art made of record and not relied upon is considered pertinent to applicant's disclosure. Cho et al. (US Patent #7,558,535), Hosein et al. (US 2004/0252658), Ozturk et al. (US 2008/0259833), Tiedemann, Jr. et al. (US Patent #5,914,950), Chen et al. (US 2010/0046481), Akbar Attar et al. (US 2007/0015476), Yoon et al. (US 2007/0097962), Oteri et al. (US 2008/0233992).

Any inquiry concerning this communication or earlier communications from the examiner should be directed to DOMINIC E. REGO whose telephone number is (571)272-8132. The examiner can normally be reached on Monday-Friday, 9:00 am-5:30 pm.

If attempts to reach the examiner by telephone are unsuccessful, the examiner's supervisor, Duc M. Nguyen can be reached on 571-272-7503. The fax phone number for the organization where this application or proceeding is assigned is 571-273-8300.

Information regarding the status of an application may be obtained from the Patent Application Information Retrieval (PAIR) system. Status information for published applications may be obtained from either Private PAIR or Public PAIR. Status information for unpublished applications is available through Private PAIR only. For more information about the PAIR system, see <http://pair-direct.uspto.gov>. Should you have questions on access to the Private PAIR system, contact the Electronic Business Center (EBC) at 866-217-9197 (toll-free). If you would like assistance from a USPTO Customer Service Representative or access to the automated information system, call 800-786-9199 (IN USA OR CANADA) or 571-272-1000.

/DOMINIC E REGO/
Primary Examiner, Art Unit 2618
Tel 571-272-8132

Notice of References Cited	Application/Control No. 12/665,427	Applicant(s)/Patent Under Reexamination MICHEL ET AL.	
	Examiner DOMINIC E. REGO	Art Unit 2618	Page 1 of 1

U.S. PATENT DOCUMENTS

*	Document Number Country Code-Number-Kind Code	Date MM-YYYY	Name	Classification
*	A	US-2007/0270175	Malladi et al.	455/522
*	B	US-2010/0029212	Malladi et al.	455/63.1
*	C	US-2008/0240013	Johnson et al.	370/315
*	D	US-2008/0247358	Damnjanovic et al.	370/329
*	E	US-2009/0034479	Wakayama et al.	370/332
*	F	US-7,558,535	Cho et al.	455/69
*	G	US-2004/0252658	Hosein et al.	370/328
*	H	US-2008/0259833	Ozturk et al.	370/310
*	I	US-5,914,950	Tiedemann et al.	370/348
*	J	US-2010/0046481	Chen et al.	370/335
*	K	US-2007/0015476	Akbar Attar et al.	455/127.1
*	L	US-2007/0097962	Yoon et al.	370/352
*	M	US-2008/0233992	Oteri et al.	455/522

FOREIGN PATENT DOCUMENTS

*	Document Number Country Code-Number-Kind Code	Date MM-YYYY	Country	Name	Classification
N					
O					
P					
Q					
R					
S					
T					

NON-PATENT DOCUMENTS

*	Include as applicable: Author, Title Date, Publisher, Edition or Volume, Pertinent Pages)
U	
V	
W	
X	

*A copy of this reference is not being furnished with this Office action. (See MPEP § 707.05(a).)
Dates in MM-YYYY format are publication dates. Classifications may be US or foreign.

EAST Search History

EAST Search History (Prior Art)

Ref #	Hits	Search Query	DBs	Default Operator	Plurals	Time Stamp
S1	1	12/665427	US-PGPUB; USPAT; USOCR; FPRS; EPO; JPO	OR	ON	2012/03/16 10:59
S2	65	power near2 control\$4 near2 head\$room	US-PGPUB; USPAT; USOCR; FPRS; EPO; JPO	OR	ON	2012/03/17 17:14
S3	23	power near2 control\$4 near2 head\$room near3 report\$3	US-PGPUB; USPAT; USOCR; FPRS; EPO; JPO	OR	ON	2012/03/17 17:16
S4	0	S3 and (close inner) near2 loop near2 power	US-PGPUB; USPAT; USOCR; FPRS; EPO; JPO	OR	ON	2012/03/17 17:25
S5	4	S3 and (closed inner) near2 loop near2 power	US-PGPUB; USPAT; USOCR; FPRS; EPO; JPO	OR	ON	2012/03/17 17:30
S6	19534	455/522,67.11,68-70,115.3,126,127.1,127.2,135,226.3,277.2,296.ccls.370/318.ccls.	US-PGPUB; USPAT; USOCR; FPRS; EPO; JPO	OR	ON	2012/03/17 17:33
S7	7	S3 and S6	US-PGPUB; USPAT; USOCR; FPRS; EPO; JPO	OR	ON	2012/03/17 17:33
S8	17078	S6 and (@ad <= "20070620" @rlad <=	US-	OR	ON	2012/03/17

		"20070620" @pd <= "20070620")	PGPUB; USPAT; USOCR; FPRS; EPO; JPO			17:42
S10	1	S7 and (@ad <= "20070620" @rlad <= "20070620" @pd <= "20070620")	US- PGPUB; USPAT; USOCR; FPRS; EPO; JPO	OR	ON	2012/03/17 17:43
S11	22	S2 and (@ad <= "20070620" @rlad <= "20070620" @pd <= "20070620")	US- PGPUB; USPAT; USOCR; FPRS; EPO; JPO	OR	ON	2012/03/17 17:45
S12	606	power near3 head\$room same (target threshold reference pre\$defin\$3 pre\$determin\$3 limit level pre\$set near value than)	US- PGPUB; USPAT; USOCR; FPRS; EPO; JPO	OR	ON	2012/03/17 17:54
S13	432	power near3 head\$room same (target threshold reference pre\$defin\$3 pre\$determin\$3 pre\$set)	US- PGPUB; USPAT; USOCR; FPRS; EPO; JPO	OR	ON	2012/03/17 17:55
S14	12	power near3 head\$room same adjust\$3 near4 (target threshold reference pre\$defin\$3 pre\$determin\$3 pre\$set)	US- PGPUB; USPAT; USOCR; FPRS; EPO; JPO	OR	ON	2012/03/17 17:56
S15	8	S14 and (@ad <= "20070620" @rlad <= "20070620" @pd <= "20070620")	US- PGPUB; USPAT; USOCR; FPRS; EPO; JPO	OR	ON	2012/03/17 17:56
S17	143	power near2 head\$room same (target threshold reference pre\$defin\$3 pre\$determin\$3 pre\$set) same (up\$link reverse)	US- PGPUB; USPAT; USOCR; FPRS; EPO; JPO	OR	ON	2012/03/18 11:00
S18	57	S17 and (@ad <= "20070620" @rlad <= "20070620" @pd <= "20070620")	US- PGPUB; USPAT; USOCR; FPRS; EPO;	OR	ON	2012/03/18 11:00

EAST Search History

			JPO			
S19	262	(juergen near2 michel).in. (klaus near2 ingemann near2 pedersen).in. (claudio near rosa).in.	US-PGPUB; USPAT; USOCR; FPRS; EPO; JPO	OR	ON	2012/03/18: 18:37
S20	28508	nokia.as.	US-PGPUB; USPAT; USOCR; FPRS; EPO; JPO	OR	ON	2012/03/18: 18:38
S21	215	(power near2 head\$room).dlm.	US-PGPUB; USPAT; USOCR; FPRS; EPO; JPO	OR	ON	2012/03/18: 18:39
S22	3	S19 and S21	US-PGPUB; USPAT; USOCR; FPRS; EPO; JPO	OR	ON	2012/03/18: 18:39
S23	2	S20 and S21	US-PGPUB; USPAT; USOCR; FPRS; EPO; JPO	OR	ON	2012/03/18: 18:42
S24	202	power near2 head\$room near2 report\$3	US-PGPUB; USPAT; USOCR; FPRS; EPO; JPO	OR	ON	2012/03/18: 18:43
S25	81	S24 same (target threshold reference pre\$defin\$3 pre\$determin\$3 pre\$set)	US-PGPUB; USPAT; USOCR; FPRS; EPO; JPO	OR	ON	2012/03/18: 18:44
S26	5	S25 and (@ad <= "20070620" @rlad <= "20070620" @pd <= "20070620")	US-PGPUB; USPAT; USOCR; FPRS; EPO; JPO	OR	ON	2012/03/18: 18:44
S27	21	power near2 head\$room same (path\$loss path near2 loss) near2 (measur\$3 measurement)	US-PGPUB; USPAT; USOCR;	OR	ON	2012/03/18: 23:04

			FPRS; EPO; JPO			
S28	3	S27 and (@ad <= "20070620" @rlad <= "20070620" @pd <= "20070620")	US-PGPUB; USPAT; USOCR; FPRS; EPO; JPO	OR	ON	2012/03/18 23:04
S29	60	power near2 head\$room same (path\$loss path near2 loss) same (target threshold reference pre\$defin\$3 pre\$determin\$3 pre\$set)	US-PGPUB; USPAT; USOCR; FPRS; EPO; JPO	OR	ON	2012/03/18 23:50
S30	2	S29 and (@ad <= "20070620" @rlad <= "20070620" @pd <= "20070620")	US-PGPUB; USPAT; USOCR; FPRS; EPO; JPO	OR	ON	2012/03/18 23:51
S31	19	power same head\$room same ((clos\$2 inner) near2 loop) same (target threshold reference pre\$defin\$3 pre\$determin\$3 pre\$set)	US-PGPUB; USPAT; USOCR; FPRS; EPO; JPO	OR	ON	2012/03/19 10:40
S32	16	S31 and (@ad <= "20070620" @rlad <= "20070620" @pd <= "20070620")	US-PGPUB; USPAT; USOCR; FPRS; EPO; JPO	OR	ON	2012/03/19 10:41
S33	19	power same head\$room and (adjust\$3 correct\$3) near4 ((clos\$2 inner) near2 loop) same (target threshold reference pre\$defin\$3 pre\$determin\$3 pre\$set)	US-PGPUB; USPAT; USOCR; FPRS; EPO; JPO	OR	ON	2012/03/19 10:42
S34	9	S33 and (@ad <= "20070620" @rlad <= "20070620" @pd <= "20070620")	US-PGPUB; USPAT; USOCR; FPRS; EPO; JPO	OR	ON	2012/03/19 10:43
S35	1	power and head\$room and (adjust\$3 correct\$3) near4 ((clos\$2 inner) near2 loop) with (reach\$3 met)	US-PGPUB; USPAT; USOCR; FPRS; EPO; JPO	OR	ON	2012/03/19 10:49
S36	12	power same head\$room same (alter\$3 chang\$3 substitut\$3 replac\$3 vary\$3 modify\$3 adjust\$3	US-PGPUB;	OR	ON	2012/03/19 10:53

		correct\$3) with ((clos\$2 inner) near2 loop)	USPAT; USOCR; FPRS; EPO; JPO			
S37	10	S36 and (@ad <= "20070620" @rlad <= "20070620" @pd <= "20070620")	US-PGPUB; USPAT; USOCR; FPRS; EPO; JPO	OR	ON	2012/03/19 10:53
S38	90	power same head\$room and (alter\$3 chang\$3 substitut\$3 replac\$3 vary\$3 modify\$3 adjust\$3 correct\$3) near6 ((clos\$2 inner) near2 loop)	US-PGPUB; USPAT; USOCR; FPRS; EPO; JPO	OR	ON	2012/03/19 10:57
S39	59	S38 and (@ad <= "20070620" @rlad <= "20070620" @pd <= "20070620")	US-PGPUB; USPAT; USOCR; FPRS; EPO; JPO	OR	ON	2012/03/19 10:59
S40	0	power same head\$room and (alter\$3 chang\$3 substitut\$3 replac\$3 vary\$3 modify\$3 adjust\$3 correct\$3) near6 ((open\$2 outer) near2 loop) same (tim\$3 near2 interval tti)	US-PGPUB; USPAT; USOCR; FPRS; EPO; JPO	OR	ON	2012/03/19 11:48
S41	0	power same head\$room and (alter\$3 chang\$3 substitut\$3 replac\$3 vary\$3 modify\$3 adjust\$3 correct\$3) with ((open\$2 outer) near2 loop) same (tim\$3 near2 interval\$3 tti)	US-PGPUB; USPAT; USOCR; FPRS; EPO; JPO	OR	ON	2012/03/19 11:49
S42	297	(alter\$3 chang\$3 substitut\$3 replac\$3 vary\$3 modify\$3 adjust\$3 correct\$3) with ((open\$2 outer) near2 loop) same (tim\$3 near2 interval\$3 tti)	US-PGPUB; USPAT; USOCR; FPRS; EPO; JPO	OR	ON	2012/03/19 11:49
S43	0	S42 and power and head\$room	US-PGPUB; USPAT; USOCR; FPRS; EPO; JPO	OR	ON	2012/03/19 11:49
S44	0	S42 and head\$room	US-PGPUB; USPAT; USOCR; FPRS; EPO; JPO	OR	ON	2012/03/19 11:49

EAST Search History

S45	33	(alter\$3 chang\$3 substitut\$3 replac\$3 vary\$3 modify\$3 adjust\$3 correct\$3) near4 ((open\$2 outer) near2 loop) with (tim\$3 near2 interval\$3 tti) same (target threshold reference pre\$defin\$3 pre\$determin\$3 pre\$set)	US-PGPUB; USPAT; USOCR; FPRS; EPO; JPO	OR	ON	2012/03/19 11:52
S46	29	S45 and (@ad <= "20070620" @rlad <= "20070620" @pd <= "20070620")	US-PGPUB; USPAT; USOCR; FPRS; EPO; JPO	OR	ON	2012/03/19 11:53
S47	9	(transmi\$6 near2 tim\$3 near2 interval\$3 tti) with (target threshold reference pre\$defin\$3 pre\$determin\$3 pre\$set) same power same head\$room	US-PGPUB; USPAT; USOCR; FPRS; EPO; JPO	OR	ON	2012/03/19 12:20
S48	2	S47 and (@ad <= "20070620" @rlad <= "20070620" @pd <= "20070620")	US-PGPUB; USPAT; USOCR; FPRS; EPO; JPO	OR	ON	2012/03/19 12:21

3/ 19/ 2012 6:05:55 PM

C:\Users\drego\Documents\EAST\Workspaces\12665427.wsp

Receipt date: 01/11/2010

12665427 - GAU: 2618

Page No.: 1 of 1

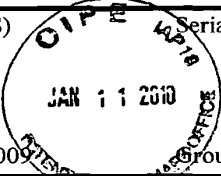
INFORMATION DISCLOSURE CITATION FORM FOR PATENT APPLICATION (FORM PTO-1449) (Substitute)	Docket No.: 863.0156.U1(US) Applicant(s): Michel et al. Filing Date: December 18, 2009		Serial No.: 12/665,427 Group:
-----------------------------------------------------------------------------------------------------------------	------------------------------------------------------------------------------------------------------	------------------------------------------------------------------------------------	--------------------------------------

U.S. PATENT DOCUMENTS

Examiner Initials	Document Number (Number-Kind Code)	Publication Date (MM-DD-YYYY)	Name of Patentee or Applicant	Class	Sub-class
	US-				
	US-				
	US-				
	US-				
	US-				
	US-				
	US-				
	US-				
	US-				
	US-				
	US-				
	US-				
	US-				

FOREIGN PATENT DOCUMENTS

Examiner Initials	Document Number (Country Code-Number-Kind Code)	Publication Date (MM-DD-YYYY)	Name Of Patentee of Applicant	Translation? Yes/No/n/a
	- -			
	- -			
	- -			

OTHER DOCUMENTS (Author (Capitalize), Title, Date, Pages, Etc., if known)

	3GPP TS 36.300 V8.0.0 (2007-03); 3 rd Generation Partnership Project; Technical Specification Group Radio Access Network; Evolved Universal Terrestrial Radio Access (E-UTRA) and Evolved Universal Terrestrial Radio Access Network (E-UTRAN); Overall Description; Stage 2 (Release 8).

Examiner's Signature: /Dominic Rego/	Date Considered: 03/15/2012
Initial if reference was considered, whether or not citation is in conformance with MPEP. Mark through citation if not considered. Include a copy of this citation form with your next correspondence to the Applicant(s).	

ALL REFERENCES CONSIDERED EXCEPT WHERE LINED THROUGH. /D.R./



UNITED STATES PATENT AND TRADEMARK OFFICE

UNITED STATES DEPARTMENT OF COMMERCE
 United States Patent and Trademark Office
 Address: COMMISSIONER FOR PATENTS
 P.O. Box 1450
 Alexandria, Virginia 22313-1450
 www.uspto.gov

BIB DATA SHEET

CONFIRMATION NO. 1011

SERIAL NUMBER 12/665,427	FILING or 371(c) DATE 01/22/2010 RULE	CLASS 455	GROUP ART UNIT 2618	ATTORNEY DOCKET NO. 863.0156.U1(US)	
APPLICANTS Juergen Michel, Munchen, GERMANY; Klaus Ingemann Pedersen, Aalborg, DENMARK; Claudio Rosa, Randers, DENMARK; ** CONTINUING DATA ***** This application is a 371 of PCT/FI08/50384 06/23/2008 which claims benefit of 60/936,649 06/20/2007 ** FOREIGN APPLICATIONS ***** ** IF REQUIRED, FOREIGN FILING LICENSE GRANTED ** 03/30/2010					
Foreign Priority claimed <input type="checkbox"/> Yes <input checked="" type="checkbox"/> No 35 USC 119(a-d) conditions met <input type="checkbox"/> Yes <input checked="" type="checkbox"/> No Verified and Acknowledged <u>/DOMINIC E REGO/</u> Examiner's Signature	<input type="checkbox"/> Met after Allowance Initials	STATE OR COUNTRY GERMANY	SHEETS DRAWINGS 4	TOTAL CLAIMS 39	INDEPENDENT CLAIMS 6
ADDRESS HARRINGTON & SMITH 4 RESEARCH DRIVE, Suite 202 SHELTON, CT 06484-6212 UNITED STATES					
TITLE Power Headroom Reporting Method					
FILING FEE RECEIVED 2758	FEES: Authority has been given in Paper No. _____ to charge/credit DEPOSIT ACCOUNT No. _____ for following:		<input type="checkbox"/> All Fees <input type="checkbox"/> 1.16 Fees (Filing) <input type="checkbox"/> 1.17 Fees (Processing Ext. of time) <input type="checkbox"/> 1.18 Fees (Issue) <input type="checkbox"/> Other _____ <input type="checkbox"/> Credit		

<i>Index of Claims</i> 	Application/Control No. 12665427	Applicant(s)/Patent Under Reexamination MICHEL ET AL.
	Examiner DOMINIC E REGO	Art Unit 2618

✓	Rejected
=	Allowed

-	Cancelled
÷	Restricted

N	Non-Elected
I	Interference

A	Appeal
O	Objected

Claims renumbered in the same order as presented by applicant
 CPA
 T.D.
 R.1.47

CLAIM		DATE									
Final	Original	03/15/2012									
	1	✓									
	2	✓									
	3	✓									
	4	✓									
	5	✓									
	6	✓									
	7	✓									
	8	✓									
	9	✓									
	10	✓									
	11	✓									
	12	✓									
	13	✓									
	14	✓									
	15	✓									
	16	✓									
	17	✓									
	18	✓									
	19	✓									
	20	✓									
	21	✓									
	22	✓									
	23	✓									
	24	✓									
	25	✓									
	26	✓									
	27	✓									
	28	✓									
	29	✓									
	30	✓									
	31	✓									
	32	✓									
	33	✓									
	34	✓									
	35	✓									
	36	✓									

<i>Index of Claims</i> 	Application/Control No. 12665427	Applicant(s)/Patent Under Reexamination MICHEL ET AL.
	Examiner DOMINIC E REGO	Art Unit 2618

✓	Rejected
=	Allowed

-	Cancelled
÷	Restricted

N	Non-Elected
I	Interference

A	Appeal
O	Objected

<input type="checkbox"/> Claims renumbered in the same order as presented by applicant		<input type="checkbox"/> CPA		<input type="checkbox"/> T.D.		<input type="checkbox"/> R.1.47			
CLAIM		DATE							
Final	Original	03/15/2012							
	37	✓							
	38	✓							
	39	✓							

Receipt date: 12/18/2009

12665427 - GAU: 2618

Page No.: 1 of 1

INFORMATION DISCLOSURE CITATION FORM FOR PATENT APPLICATION (FORM PTO-1449) (Substitute)		Docket No.: 863.0156.U1(US)		Serial No.: to be assigned	
		Applicant(s): Michel et al.			
		Filing Date: herewith		Group: N/A	
U.S. PATENT DOCUMENTS					
Examiner Initials	Document Number (Number-Kind Code)	Publication Date (MM-DD-YYYY)	Name of Patentee or Applicant	Class	Sub-class
	US-2003/0026324 A1 US- US- US- US- US- US- US- US- US- US- US- US-	02-06-2003	Li et al.		
FOREIGN PATENT DOCUMENTS					
Examiner Initials	Document Number (Country Code-Number-Kind Code)	Publication Date (MM-DD-YYYY)	Name Of Patentee of Applicant	Translation? Yes/No/n/a	
	EP I 311 076 A1 EP I 628 413 A2 WO 00/03499 WO 00/62441 - - - - - -	05-14-2003 02-22-2006 01-20-2000 10-19-2000	Lucent Technologies Inc. Samsung Electronics Co., Ltd. Samsung Electronics Co., Ltd. Telefonaktiebolaget LM Ericsson		
OTHER DOCUMENTS (Author (Capitalize), Title, Date, Pages, Etc., if known)					
Examiner's Signature: /Dominic Rego/			Date Considered: 03/15/2012		
Initial if reference was considered, whether or not citation is in conformance with MPEP. Mark through citation if not considered. Include a copy of this citation form with your next correspondence to the Applicant(s).					

ALL REFERENCES CONSIDERED EXCEPT WHERE LINED THROUGH. /D.R./

Search Notes 	Application/Control No. 12665427	Applicant(s)/Patent Under Reexamination MICHEL ET AL.
	Examiner DOMINIC E REGO	Art Unit 2618

SEARCHED			
Class	Subclass	Date	Examiner
455	522, 67.11, 68-70, 115.3, 126, 127.1, 127.2, 135, 226.3, 277.2, 296	3/15/2012	DR
370	318	3/15/2012	DR

SEARCH NOTES		
Search Notes	Date	Examiner
EAST, Inventor, and Assignee Search	3/15/2012	DR

INTERFERENCE SEARCH			
Class	Subclass	Date	Examiner

--	--



DFW

IN THE U.S. PATENT AND TRADEMARK OFFICE

In re U.S. Patent Application of:

APPLICANTS: Juergen Michel et al.

SERIAL NO.: 12/665,427 FILING DATE: January 22, 2010

EXAMINER: Rego, Dominic E ART UNIT: 2618

ATTORNEY'S DOCKET NO.: 863.0156.U1 (US)

TITLE: POWER HEADROOM REPORTING METHOD

Mail Stop Amendment
Commissioner for Patents
P.O. Box 1450
Alexandria, VA 22313-1450

RESPONSE TO OFFICE ACTION

Sir:

This paper is herewith filed in response to the Examiner's Office Action mailed on March 22, 2012 for the above-captioned U.S. Patent Application. This Response is filed within three months following the shortened statutory period for reply recited in the referenced Office Action. Please consider this as a petition for an extension of time necessary to effect this Response, and charge Deposit Account No. 50-1924 (\$1270) for an extension of time fee. However, should the undersigned attorney be mistaken, please consider this a petition for any extension of time that may be required to maintain the pendency of this Patent Application, and charge deposit account no. 50-1924 for any required fee deficiency.

09/25/2012 ZJUHR1 00000048 501924 12665427
01 FC:1253 1270.00 DA

S.N.: 12/665,427
Art Unit: 2618

AMENDMENTS TO THE CLAIMS:

This listing of the claims will replace all prior versions, and listings, of the claims in this application.

Listing of Claims:

1. (Currently Amended) A method comprising:
determining that a set of at least one triggering criterion is met; and
providing a power control headroom report on an uplink from user equipment, in response to determining that the set is met, wherein said at least one triggering criterion include [[a]] at least one threshold having been reached, wherein said at least one threshold is adjustable via a signal to the user equipment.
2. (Currently Amended) The method of claim 1, wherein said ~~threshold is adjustable via a signal to the user equipment~~ power control headroom report is for use in a power control correction command to the user equipment.
3. (Currently Amended) The method of claim 1, wherein the set of at least one triggering criterion comprises a triggering criterion such that an absolute difference between current and most recent path-loss measurements has reached a threshold of difference.
4. (Currently Amended) The method of claim 1, wherein said set of at least one triggering criterion include any one of a plurality of criteria that each entail ~~Teaching~~ teaching a respective threshold.
5. (Currently Amended) The method of ~~claim 4~~ claim 1, wherein the ~~plurality set of at least one triggering criterion~~ criteria comprise a first criterion, a second criterion, and a third criterion.

S.N.: 12/665,427
Art Unit: 2618

6. (Currently Amended) The method of claim 1, wherein the set of at least one triggering criterion comprises a criterion ~~such that a number of received~~ being met based on reaching a threshold of the at least one threshold of n closed loop power corrections has reached a threshold of corrections having been received by the user equipment over m transmission time intervals, wherein n and m are integers and wherein said at least one threshold adjustable via the signal comprises adjusting the threshold integers n and m.

7. (Currently Amended) The method of claim 1, wherein the set of at least one triggering criterion comprises a criterion ~~such that an amount of~~ being met based on reaching a threshold of the at least one threshold of m transmission time intervals, following an open loop power control modification, has reached a threshold of intervals since modification, wherein m is an integer and wherein said at least one threshold adjustable via the signal comprises adjusting the threshold integer m.

8. (Currently Amended) The method of claim 1, wherein the set of at least one triggering criterion comprises a criterion ~~such that an amount of~~ being met based on reaching a threshold of the at least one threshold of k transmission time intervals [[,]] following a previous power control headroom report, has reached a threshold of intervals since reporting, wherein k is an integer and wherein said at least one threshold adjustable via the signal comprises adjusting the threshold integer k.

9. (Currently Amended) The method of claim 5, wherein the first criterion is such that a number of received closed loop power corrections has reached a threshold of corrections, and wherein the second criterion is such that an amount of transmission time intervals[[,]] following an open loop power control modification[[,]] has reached a threshold of intervals since modification.

10. (Currently Amended) The method of claim 9, wherein the third criterion is such that an amount of transmission time intervals[[,]] following a previous power control headroom report[[,]] has reached a threshold of intervals since reporting.

11. (Original) The method of claim 9, wherein the third criterion is such that an absolute difference between current and most recent path-loss measurements has reached a threshold of difference.

12. (Currently Amended) An apparatus comprising:

means for determining that a set of at least one triggering criterion is met; and

means for providing a power control headroom report on an uplink from user equipment, in response to the set having been met, wherein said at least one triggering criterion include [[a]] at least one threshold having been reached power correction, wherein said at least one threshold is adjustable via a signal to the apparatus.

13. (Currently Amended) The apparatus of claim 12, wherein said ~~threshold is adjustable via a signal to the user equipment~~ power control headroom report is for use in a power control correction command to the apparatus.

14. (Currently Amended) The apparatus of claim 12, wherein the set of at least one triggering criterion comprises a criterion such that an absolute difference between current and most recent path-loss measurements has reached a threshold of difference.

15. (Original) The apparatus of claim 12, wherein said set of at least one triggering criterion include any one of a plurality of criteria that each entail reaching a respective threshold.

16. (Currently Amended) The apparatus of ~~claim 15~~ claim 12, wherein the ~~plurality set of at least one triggering~~ criteria comprise a first criterion, a second criterion, and a third criterion.

17. (Currently Amended) The apparatus of claim 16, wherein the first criterion is such that a number of received closed loop power corrections has reached a threshold of corrections, and wherein the second criterion is such that an amount of transmission time intervals~~[[,]]~~

S.N.: 12/665,427
Art Unit: 2618

following an open loop power control modification[[,]] has reached a threshold of intervals since modification.

18. (Currently Amended) The apparatus of claim 17, wherein the third criterion is such that an amount of transmission time intervals[[,]] following a previous power control headroom report[[,]] has reached a threshold of intervals since reporting.

19. (Currently Amended) The apparatus of claim 17, wherein the third criterion is such that an absolute difference between current and most recent path-loss measurements has reached a threshold of difference.

20. (Currently Amended) ~~Apparatus~~ An apparatus comprising:

at least one processor; and

at least one memory including software, where the at least one memory and the software are configured, with the at least one processor, to cause the apparatus to at least:

~~a triggering module configured to~~ determine that a set of at least one triggering criterion is met; and

~~a transceiver configured to~~ provide a power control headroom report on an uplink from said user equipment, in response to the set having been met, wherein said at least one triggering criterion include [[a]] at least one threshold having been reached, wherein said at least one threshold is adjustable via a signal to the apparatus.

21. (Currently Amended) The apparatus of claim 20, wherein said ~~threshold is adjustable via a signal to the apparatus~~ power control headroom report is for use in a power control correction command to the apparatus.

S.N.: 12/665,427
Art Unit: 2618

22. (Currently Amended) The apparatus of claim 20, wherein the set of at least one triggering criteria comprises a triggering criterion such that an absolute difference between current and most recent path-loss measurements has reached a threshold of difference.

23. (Original) The apparatus of claim 20, wherein said set of at least one triggering criterion include any one of a plurality of criteria that each entail reaching a respective threshold.

24. (Original) The apparatus of claim 23, wherein the plurality of criteria comprise a first criterion, a second criterion, and a third criterion.

25. (Original) The apparatus of claim 24, wherein the first criterion is such that a number of received closed loop power corrections has reached a threshold of corrections, and wherein the second criterion is such that an amount of transmission time intervals, following an open loop power control modification, has reached a threshold of intervals since modification.

26. (Currently Amended) The apparatus of claim 24, wherein the ~~third~~ second criterion is such that an amount of transmission time intervals[[,]] following a previous power control headroom report[[,]] has reached a threshold of intervals since reporting.

27. (Original) The apparatus of claim 24, wherein the third criterion is such that an absolute difference between current and most recent path-loss measurements has reached a threshold of difference.

28. (Currently Amended) A ~~computer program product comprising a~~ non-transitory computer readable medium including software having executable code stored therein; the code, that when executed by a processor, is adapted to carry out [[the]] functions of:

determining that a set of at least one triggering criterion is met; and

providing a power control headroom report on an uplink from user equipment, in response to the set having been met, wherein said at least one triggering criterion include [[a]]

S.N.: 12/665,427
Art Unit: 2618

at least one threshold having been reached, wherein said at least one threshold is adjustable via a signal to the user equipment.

29. (Currently Amended) The computer ~~program-product~~ readable medium of claim 28, wherein said ~~threshold is adjustable via a signal~~ power control headroom report is for use in a power control correction command to the user equipment.

30. (Currently Amended) The computer ~~program-product~~ readable medium of claim 28, wherein the set comprises a criterion such that an absolute difference between current and most recent path-loss measurements has reached a threshold of difference.

31. (Currently Amended) The computer ~~program-product~~ readable medium of claim 28, wherein said set of at least one triggering criterion include any one of a plurality of criteria that each entail reaching a respective threshold.

32. (Currently Amended) The computer ~~program-product~~ readable medium of claim 31, wherein the plurality of criteria comprise a first criterion, a second criterion, and a third criterion.

33. (Currently Amended) The computer ~~program-product~~ readable medium of claim 32, wherein the first criterion is such that a number of received closed loop power corrections has reached a threshold of corrections, and wherein the second criterion is such that an amount of transmission time intervals, following an open loop power control modification, has reached a threshold of intervals since modification.

34. (Currently Amended) A network element comprising:

at least one processor; and

at least one memory including software, where the at least one memory and the

S.N.: 12/665,427
Art Unit: 2618

software are configured, with the at least one processor, to cause the network element to at least:

~~a report receiving module configured to receive a power control headroom report on an uplink from user equipment, in response to the user equipment determining that a set of at least one triggering criterion is met because [[a]] at least one threshold has been reached, and~~
~~a threshold adjustment module, configured to provide a threshold adjustment signal to the user equipment in order to adjust the at least one threshold.~~

35. (Original) The network element of claim 34, wherein the set comprises a criterion such that an absolute difference between current and most recent path-loss measurements has reached a threshold of difference.

36. (Currently Amended) The network element of claim 34, ~~further comprising a correction module configured~~ wherein the at least one memory including the software is configured with the at least one processor to cause the network element to provide a closed loop power control correction command signal to the user equipment at least partly in response to said power control headroom report.

37. – 39. (Cancelled)

S.N.: 12/665,427
Art Unit: 2618

REMARKS:

This paper is herewith filed in response to the Examiner's Office Action mailed on March 22, 2012 for the above-captioned U.S. Patent Application. This office action is a rejection of claims 1-39 of the application.

More specifically, the Examiner has rejected claims 28-33 under 35 USC 101 asserting that the claimed invention is directed to non-statutory subject matter; rejected claims 1-2, 4-5, 12-13, 15-16, 20-21, 23-24, 28-29, 31-32, 34, and 37 under 35 USC 102(e) as being anticipated by Malladi (US20070270175); rejected claims 3, 14, 22, 30, 35, and 38 under 35 USC 103(a) as being unpatentable over Milladi in view of Milladi (US20100029212) hereafter referred to as Milladi*212; rejected claims 6 and 36 under 35 USC 103(a) as being unpatentable over Milladi in view of Johnson (US20080240013); rejected claim 7 under 35 USC 103(a) as being unpatentable over Milladi in view of Damnjanovic (US20080247358); rejected claim 8 under 35 USC 103(a) as being unpatentable over Milladi in view of Yavuz (US20090034474); rejected claims 9, 17, 25, 33, and 39 under 35 USC 103(a) as being unpatentable over Milladi in view of Johnson and further in view of Damnjanovic; rejected claims 8, 18, and 26 under 35 USC 103(a) as being unpatentable over Malladi in view of Johnson in view of Damnjanovic, and further in view of Yavuz (US20090034474); and rejected claims 11, 19, and 27 under 35 USC 103(a) as being unpatentable over Milladi in view of Johnson in view of Damnjanovic, and further in view of Milladi*212. The rejections are respectfully traversed.

Claims 1-10, 12-14, 17-22, 26, 28, 34 and 36 have been amended. Claims 37-40 have been cancelled without prejudice or disclaimer. Support for the amendments can be found at least page 6, line 22 to page 7, line 16 and page 8, line 9 to page 9, line 6 of the Application as filed. No new matter is added.

First, regarding the rejection of claims 28-33 under 35 USC 101, these claims have been amended to address the rejection. The Examiner is respectfully requested to remove the rejection under 35 USC 101.

S.N.: 12/665,427
Art Unit: 2618

Regarding the objection to the specification as indicated on page 3 of the Office Action, the claims have been amended to replace the term “computer program product” with the term “software.” This language is at least supported on page 8, lines 22-26 of the Application as filed. For at least these reasons the Examiner is requested to remove the objection to the specification.

In addition, for similar reasons the amendments to apparatus claim 20 and network element claims 34 and 36 are also supported by the specification.

Regarding the Rejection of Independent Claims 1, 12, 20, and 28

Although the rejections are not expressly or impliedly agree with, in order to facilitate the prosecution of this patent application towards allowance each of the Independent claims 1, 12, 20, and 28 have been amended in a somewhat similar fashion to recite features similar to claims 2, 13, 21, and 29, respectively. For example, claim 1 now recites:

A method comprising: determining that a set of at least one triggering criterion is met; and providing a power control headroom report on an uplink from user equipment, in response to determining that the set is met, wherein said at least one triggering criterion include at least one threshold having been reached, wherein said at least one threshold is adjustable via a signal to the user equipment

Regarding the rejection of claim 2, now similarly incorporated in claim 1, the Examiner states:

“Regarding claim 2, Malladi teaches the method of claim 1, wherein said threshold is adjustable via a signal to the user equipment (Paragraph 0025, 0030, and 0097),” (page 4 of the Office Action).

Malladi discloses:

“Systems and methods are provided for mitigating interference in a wireless network by controlling transmitter power levels in the network. In one embodiment, a method for controlling power in a wireless network is provided.

The method includes determining a relative power parameter at a wireless device such as a mobile wireless terminal and receiving a load parameter at the wireless device, where the load parameter is associated with at least one other wireless cell. The method includes adjusting transmit power of the wireless device in view of the relative power parameter and the load parameter. In another embodiment, the transmit power can be controlled in view of an absolute power spectral density parameter. In still yet another embodiment, along with relative power and absolute power spectral density parameters, transmit power can be adjusted in view of a relative power spectral density parameter,” (emphasis added), (paragraph [0025]); and

“In an embodiment, the power control component 160 employs the load indicator bits noted above and another parameter such as power headroom, where such headroom can be a function of a reference signal maintained at the stations 124-130 plus the maximum deliverable power by given devices 144-150. Based on such parameters, power transmissions can be tailored at the transmitting device 144-150 in the cell 124-130 to reduce the impact on devices within the cells or devices associated with other cells. In another embodiment, the power density control component 170 controls the power headroom parameter (or relative transmit power capability) along with a parameter referred to as absolute power spectral density at the devices 144-150. Based on this combination of power headroom and absolute power spectral density, devices 144-150 operating in a given cell 124-130 can adjust a given transmit power output in order to mitigate interference,” (emphasis added), (paragraph [0030]); and

“FIG. 10 is an illustration of a system 1000 for controlling power in accordance with a wireless terminal. In general, the system 1000 is related to a wireless communications apparatus to control transmitted power. This includes a logical component 1002 for receiving load parameters associated with wireless network cells. For example, this could include a receiver circuit in a wireless terminal or other receiver components. At 1004, a logical component is provided for generating a power headroom parameter based on a received reference signal. This could include a processor associated with a wireless terminal. At 1006, a logical component is provided for adjusting power based in part on the load parameters and the power headroom parameter. This can include processor instructions or hardware to execute a power control algorithm for example. At 1008, a logical component is provided for adjusting power based on an absolute power spectral density parameter, where this module can also include components of an algorithm,” (paragraph [0097])

The rejection is vague; however the Examiner appears to assert that the load parameter or load indicator bits or else the reference signal received by the wireless terminal of Milladi is somehow disclosing a signal to adjust a threshold of triggering criterion for a power control headroom

S.N.: 12/665,427
Art Unit: 2618

report at the wireless terminal. First, none of these paragraphs of Malladi disclose any operation using a threshold, for that matter in all of Malladi there is no disclosure of a threshold. Similarly, Malladi does not disclose any operation where these parameters are used to adjust a threshold by the wireless terminal of Malladi. Malladi discloses:

“Thus, one parameter that may be communicated between cells 110-120 indicates the general notion of load in the cell, where a load indicator bit for example, may signal that at least one device 144-150 is communicating in the cell. From these and other parameters, interference can be mitigated between cells 110-120 by employing the parameters to reduce transmit power at the respective devices 144-150 operating within a given cell,” (emphasis added), (paragraph [0029]); and

“In an embodiment, the power control component 160 employs the load indicator bits noted above and another parameter such as power headroom, where such headroom can be a function of a reference signal maintained at the stations 124-130 plus the maximum deliverable power by given devices 144-150. Based on such parameters, power transmissions can be tailored at the transmitting device 144-150 in the cell 124-130 to reduce the impact on devices within the cells or devices associated with other cells. In another embodiment, the power density control component 170 controls the power headroom parameter (or relative transmit power capability) along with a parameter referred to as absolute power spectral density at the devices 144-150. Based on this combination of power headroom and absolute power spectral density, devices 144-150 operating in a given cell 124-130 can adjust a given transmit power output in order to mitigate interference,” (paragraph [0030]).

According to Milladi the load parameter or load indicator bits and the power headroom appear to each be employed to reduce transmit power of the respective devices. However, Malladi does not disclose that the load parameter is used to adjust a threshold of triggering criterion for the power headroom in Malladi. With regards to the reference signal Milladi merely disclose that the power headroom can be a function of the reference signal. Milladi does not disclose any detail regarding this function and Milladi does not disclose that the reference signal somehow adjusts a threshold to trigger the power headroom. For at least these reasons the Examiner is respectfully requested to clarify the support for rejection in a non-final Office Action or else remove the rejection.

The basis for the Examiner's rejection is not understood. The Examiner is respectfully reminded

S.N.: 12/665,427
Art Unit: 2618

that a 35 USC 102 rejection requires that the cited art **disclose to the specificity of the rejected claim**; *Verve, LLC v. Crane Cams, Inc.*, 311 F.3d 1116, 1120, 65 USPQ2d 1051 (Fed. Cir. 2002) (“**A single reference must describe the claimed invention with sufficient precision and detail to establish that the subject matter existed in the prior art**”). It is axiomatic that a 35 USC 102(e) rejection requires strict identity with every claim element.

It is well recognized that "to constitute an anticipation, all material elements recited in a claim must be found in one unit of prior art", *Ex Parte Gould*, BPAI, 6 USPQ 2d, 1680, 1682 (1987), citing with approval *In re Marshall*, 578 F.2d 301, 304, 198 USPQ 344, 346 (CCPA 1978). Clearly, not all material elements recited in claim 1 are found in *Malladi* as asserted in the anticipation rejection.

Further, none of the references cited overcome at least the above stated shortfalls of *Malladi*.

Milladi*212

*Milladi*212* relates to a method of adjusting transmit power of the wireless device in view of the relative power parameter and the load parameter (paragraph [0025]). Similar to *Milladi*, as above, in all of *Milladi*212* there is not disclosed any operation using a threshold, no less an operation of a received signal adjusting a threshold of triggering criterion for a power control headroom. *Milladi*212* does not overcome at least the shortfalls of *Milladi* as stated above.

Johnson

Johnson discloses a method to perform closed loop power control, a receiving station measures the signal strength of a received signal, transmitted from a transmitting station, generates periodic power control commands based on the signal strength measurements, and transmits the periodic power control commands to a transmitting station to control the transmit power level of the transmitting station (Abstract). With regards to the control commands *Johnson* discloses “To briefly summarize, the base station 20 continuously monitors the uplink load and sends control

S.N.: 12/665,427
Art Unit: 2618

signals to one or more mobile stations 30 to selectively enable and disable compressed mode operation depending on the uplink load,” (paragraph [0016]). The control signals of Johnson used to enable and disable a compressed mode operation does not read on a received signal adjusting a threshold of triggering criterion for a power control headroom. In addition, similar to Malladi and Milladi*212 Johnson does not disclose a received signal adjusting a threshold of triggering criterion for a power control headroom. Johnson does not overcome at least the shortfalls of Milladi and Milladi*212 as stated above.

Damnjanovic

Damnjanovic relates to a method for a channel sensitive scheduler for scheduling transmissions in a communication system *Abstract). Damnjanovic does not disclose a received signal adjusting a threshold of triggering criterion for a power control headroom. Damnjanovic does not overcome at least the shortfalls of Milladi, Milladi*212, and Johnson as stated above.

Yavuz

Yavuz discloses a method for dynamically adjusting the transmission time interval (TTI) for a communications system are presented (Abstract). Yavuz discloses an operation identifying is whether a packet error rate of communications condition is crossing a threshold value however the threshold of Yavuz is predetermined and in a range of 0.1% and 5% (Fig. 5; paragraphs 16 and 18; and claims 18 and 46). Yavuz does not overcome at least the shortfalls of Milladi, Milladi*212, Johnson, and Damnjanovic as stated above.

None of the references cited overcome at least the shortfalls of Milladi as stated above.

For at least these reasons the rejection should be removed and claim 1 should be allowed.

In addition, the Applicants submit that, for similar reasons, the foregoing amendments to the independent claims 12, 20, and 28 also place these claims in condition for allowance in view of

S.N.: 12/665,427
Art Unit: 2618

the references cited. Therefore the Examiner is requested to remove the rejection and allow these claims.

Regarding Independent Claim 34

For at least the reasons stated above none of the references cited disclose or suggest at least where independent claim 34 recites:

“A network element comprising: at least one processor; and at least one memory including software, where the at least one memory and the software are configured, with the at least one processor, to cause the apparatus to at least: receive a power control headroom report on an uplink from user equipment, in response to the user equipment determining that a set of at least one triggering criterion is met because at least one threshold has been reached, and provide a threshold adjustment signal to the user equipment in order to adjust the at least one threshold”

Therefore, the Examiner is requested to remove the rejection and allow claim 34.

Regarding Claim 6

For at least the reasons stated above none of the references cited disclose or suggest at least where claim 6 recites in part:

“wherein the set of at least one triggering criterion comprises a criterion being met based on reaching a threshold of the at least one threshold of n closed loop power corrections having been received by the user equipment over m transmission time intervals, wherein n and m are integers and wherein said at least one threshold adjustable via the signal comprises adjusting the threshold integers n and m.”

Thus, the Examiner is requested to remove the rejection and allow claim 6.

Regarding Claim 7

S.N.: 12/665,427
Art Unit: 2618

For at least the reasons stated above none of the references cited disclose or suggest at least where claim 7 recites in part:

“wherein the set of at least one triggering criterion comprises a criterion being met based on reaching a threshold of the at least one threshold of m transmission time intervals, following an open loop power control modification, wherein m is an integer and wherein said at least one threshold adjustable via the signal comprises adjusting the threshold integer m.”

Therefore, the Examiner is requested to remove the rejection and allow claim 7.

Regarding Claim 8

For at least the reasons stated above none of the references cited disclose or suggest at least where claim 8 recites in part:

“wherein the set of at least one triggering criterion comprises a criterion being met based on reaching a threshold of the at least one threshold of k transmission time intervals following a previous power control headroom report, wherein k is an integer and wherein said at least one threshold adjustable via the signal comprises adjusting the threshold integer k.”

Therefore, the Examiner is requested to remove the rejection and allow claim 8.

In addition, for at least the reasons that claims 2-11, 13-19, 21-27, and 29-33 depend from claims 1, 12, 20, 28, and 34, respectively, the references cited do not disclose or suggest these claims.

Based on the above explanations and arguments, it is clear that the references cited cannot be seen to disclose or suggest claims 1-36. The Examiner is respectfully requested to reconsider and remove the rejections of claims 1-36 and to allow all of the pending claims 1-36 as now presented for examination.



S.N.: 12/665,427
Art Unit: 2618

For all of the foregoing reasons, it is respectfully submitted that all of the claims now present in the application are clearly novel and patentable over the prior art of record. Should any unresolved issue remain, the Examiner is invited to call Applicants' attorney at the telephone number indicated below.

Respectfully submitted:

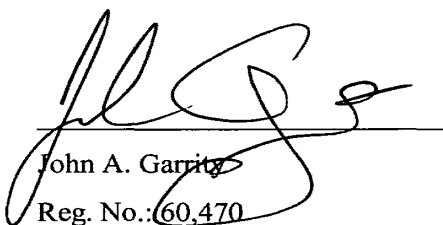
John A. Garrity
Reg. No.: 60,470

9/20/2012
Date

Customer No.: 29,683

HARRINGTON & SMITH ATTORNEYS AT LAW, LLC

4 Research Drive

Shelton, CT 06484-6212

Telephone: (203)925-9400

Facsimile: (203)944-0245

email: jgarrity@hspatent.com

CERTIFICATE OF MAILING

I hereby certify that this correspondence is being deposited with the United States Postal Service as first class mail in an envelope addressed to: Commissioner for Patents, P.O. BOX 1450, Alexandria, VA 22313-1450.

9/21/2012
Date

Clairne F. Mian
Name of Person Making Deposit

Under the Paperwork Reduction Act of 1995, no persons are required to respond to a collection of information unless it displays a valid OMB control number.

PATENT APPLICATION FEE DETERMINATION RECORD Substitute for Form PTO-875					Application or Docket Number 12/665,427		Filing Date 01/22/2010		<input type="checkbox"/> To be Mailed		
APPLICATION AS FILED – PART I							OTHER THAN SMALL ENTITY				
(Column 1)			(Column 2)		SMALL ENTITY <input type="checkbox"/>		OR		OTHER THAN SMALL ENTITY		
FOR		NUMBER FILED	NUMBER EXTRA		RATE (\$)	FEE (\$)	OR		RATE (\$)	FEE (\$)	
<input type="checkbox"/> BASIC FEE (37 CFR 1.16(a), (b), or (c))		N/A	N/A		N/A				N/A		
<input type="checkbox"/> SEARCH FEE (37 CFR 1.16(k), (i), or (m))		N/A	N/A		N/A		N/A				
<input type="checkbox"/> EXAMINATION FEE (37 CFR 1.16(o), (p), or (q))		N/A	N/A		N/A		N/A				
TOTAL CLAIMS (37 CFR 1.16(i))		minus 20 =	*		X \$ =		X \$ =				
INDEPENDENT CLAIMS (37 CFR 1.16(h))		minus 3 =	*		X \$ =		X \$ =				
<input type="checkbox"/> APPLICATION SIZE FEE (37 CFR 1.16(s))		If the specification and drawings exceed 100 sheets of paper, the application size fee due is \$250 (\$125 for small entity) for each additional 50 sheets or fraction thereof. See 35 U.S.C. 41(a)(1)(G) and 37 CFR 1.16(s).									
<input type="checkbox"/> MULTIPLE DEPENDENT CLAIM PRESENT (37 CFR 1.16(j))											
					TOTAL				TOTAL		
* If the difference in column 1 is less than zero, enter "0" in column 2.											
APPLICATION AS AMENDED – PART II							OTHER THAN SMALL ENTITY				
(Column 1)			(Column 2)		SMALL ENTITY		OR		OTHER THAN SMALL ENTITY		
AMENDMENT	09/25/2012	CLAIMS REMAINING AFTER AMENDMENT		HIGHEST NUMBER PREVIOUSLY PAID FOR	PRESENT EXTRA	RATE (\$)	ADDITIONAL FEE (\$)	OR		RATE (\$)	ADDITIONAL FEE (\$)
	Total (37 CFR 1.16(i))	* 36	Minus	** 39	= 0	X \$ =				X \$60=	0
	Independent (37 CFR 1.16(h))	* 5	Minus	***6	= 0	X \$ =		X \$250=	0		
	<input type="checkbox"/> Application Size Fee (37 CFR 1.16(s))										
	<input type="checkbox"/> FIRST PRESENTATION OF MULTIPLE DEPENDENT CLAIM (37 CFR 1.16(j))										
					TOTAL ADD'L FEE				TOTAL ADD'L FEE		0
AMENDMENT		CLAIMS REMAINING AFTER AMENDMENT		HIGHEST NUMBER PREVIOUSLY PAID FOR	PRESENT EXTRA	RATE (\$)	ADDITIONAL FEE (\$)	OR		RATE (\$)	ADDITIONAL FEE (\$)
	Total (37 CFR 1.16(i))	*	Minus	**	=	X \$ =				X \$ =	
	Independent (37 CFR 1.16(h))	*	Minus	***	=	X \$ =		X \$ =			
	<input type="checkbox"/> Application Size Fee (37 CFR 1.16(s))										
	<input type="checkbox"/> FIRST PRESENTATION OF MULTIPLE DEPENDENT CLAIM (37 CFR 1.16(j))										
					TOTAL ADD'L FEE				TOTAL ADD'L FEE		
* If the entry in column 1 is less than the entry in column 2, write "0" in column 3.											
** If the "Highest Number Previously Paid For" IN THIS SPACE is less than 20, enter "20".											
*** If the "Highest Number Previously Paid For" IN THIS SPACE is less than 3, enter "3".											
The "Highest Number Previously Paid For" (Total or Independent) is the highest number found in the appropriate box in column 1.											
							Legal Instrument Examiner: /BRENDA MURPHY/				

This collection of information is required by 37 CFR 1.16. The information is required to obtain or retain a benefit by the public which is to file (and by the USPTO to process) an application. Confidentiality is governed by 35 U.S.C. 122 and 37 CFR 1.14. This collection is estimated to take 12 minutes to complete, including gathering, preparing, and submitting the completed application form to the USPTO. Time will vary depending upon the individual case. Any comments on the amount of time you require to complete this form and/or suggestions for reducing this burden, should be sent to the Chief Information Officer, U.S. Patent and Trademark Office, U.S. Department of Commerce, P.O. Box 1450, Alexandria, VA 22313-1450. DO NOT SEND FEES OR COMPLETED FORMS TO THIS ADDRESS. **SEND TO: Commissioner for Patents, P.O. Box 1450, Alexandria, VA 22313-1450.**

If you need assistance in completing the form, call 1-800-PTO-9199 and select option 2.



UNITED STATES PATENT AND TRADEMARK OFFICE

UNITED STATES DEPARTMENT OF COMMERCE
U.S. Patent and Trademark Office
Address: COMMISSIONER FOR PATENTS
P.O. Box 1450
Alexandria, Virginia 22313-1450
www.uspto.gov

29683 e 2012-10-09
HARRINGTON & SMITH
4 RESEARCH DRIVE, Suite 202
SHELTON, CT 06484-6212

Paper No.

Application No.: 12/665,427 	Date Mailed: 2012-10-09
First Named Inventor: Michel, Juergen,	Examiner: REGO, DOMINIC E
Attorney Docket No.: 863.0156.U1(US)	Art Unit: 2647
Confirmation No.: 1011	Filing Date: 2010-01-22

Please find attached an Office communication concerning this application or proceeding.

Commissioner for Patents

Notice of Non-Compliant Amendment (37 CFR 1.121)	Application No. 12/665,427	Applicant(s) MICHEL ET AL.
		Art Unit 2647

-- The MAILING DATE of this communication appears on the cover sheet with the correspondence address --

The amendment document filed on 25 September, 2012 is considered non-compliant because it has failed to meet the requirements of 37 CFR 1.121 or 1.4. In order for the amendment document to be compliant, correction of the following item(s) is required.

THE FOLLOWING MARKED (X) ITEM(S) CAUSE THE AMENDMENT DOCUMENT TO BE NON-COMPLIANT:

- 1. Amendments to the specification:
 - A. Amended paragraph(s) do not include markings.
 - B. New paragraph(s) should not be underlined.
 - C. Other _____.
- 2. Abstract:
 - A. Not presented on a separate sheet. 37 CFR 1.72.
 - B. Other _____.
- 3. Amendments to the drawings:
 - A. The drawings are not properly identified in the top margin as "Replacement Sheet," "New Sheet," or "Annotated Sheet" as required by 37 CFR 1.121(d).
 - B. The practice of submitting proposed drawing correction has been eliminated. Replacement drawings showing amended figures, without markings, in compliance with 37 CFR 1.84 are required.
 - C. Other _____.
- 4. Amendments to the claims:
 - A. A complete listing of all of the claims is not present.
 - B. The listing of claims does not include the text of all pending claims (including withdrawn claims)
 - C. Each claim has not been provided with the proper status identifier, and as such, the individual status of each claim cannot be identified. Note: the status of every claim must be indicated after its claim number by using one of the following status identifiers: (Original), (Currently amended), (Canceled), (Previously presented), (New), (Not entered), (Withdrawn) and (Withdrawn-currently amended).
 - D. The claims of this amendment paper have not been presented in ascending numerical order.
 - E. Other: Claim 19 do not include markings.
- 5. Other (e.g., the amendment is unsigned or not signed in accordance with 37 CFR 1.4): For further explanation of the amendment format required by 37 CFR 1.121, see MPEP § 714.

TIME PERIODS FOR FILING A REPLY TO THIS NOTICE:

1. Applicant is given **no new time period if the non-compliant amendment is an** after-final amendment or an amendment filed after allowance, or a drawing submission (only) If applicant wishes to resubmit the non-compliant after-final amendment with corrections, the **entire corrected amendment** must be resubmitted.
2. Applicant is given **one month**, or thirty (30) days, whichever is longer, from the mail date of this notice to supply the correction, if the non-compliant amendment is one of the following: a preliminary amendment, a non-final amendment (including a submission for a request for continued examination (RCE) under 37 CFR 1.114), a supplemental amendment filed within a suspension period under 37 CFR 1.103(a) or (c), and an amendment filed in response to a Quayle action. If any of above boxes 1 to 4 are checked, the correction required is only the corrected section of the non-compliant amendment in compliance with 37 CFR 1.121.

Extensions of time are available under 37 CFR 1.136(a) only if the non-compliant amendment is a non-final amendment or an amendment filed in response to a *Quayle* action.

Failure to timely respond to this notice will result in:

- Abandonment** of the application if the non-compliant amendment is a non-final amendment or an amendment filed in response to a *Quayle* action; or
- Non-entry** of the amendment if the non-compliant amendment is a preliminary amendment or supplemental amendment.

Legal Instruments Examiner (LIE), if applicable /BRENDA MURPHY/

Telephone No: (571)272-1033



lfu

IN THE U.S. PATENT AND TRADEMARK OFFICE

In re U.S. Patent Application of:

APPLICANTS: Juergen Michel et al.

SERIAL NO.: 12/665,427 FILING DATE: January 22, 2010

EXAMINER: Rego, Dominic E ART UNIT: 2618/2647 (per Notice)

ATTORNEY'S DOCKET NO.: 863.0156.U1 (US)

TITLE: POWER HEADROOM REPORTING METHOD

Mail Stop Amendment
Commissioner for Patents
P.O. Box 1450
Alexandria, VA 22313-1450

RESPONSE TO NOTICE OF NON-COMPLIANT AMENDMENT

Sir:

This paper is herewith filed in response to the Examiner's Notice of Non-Compliant Amendment mailed on October 9, 2012 for the above-captioned U.S. Patent Application. This Response is filed within the one month period for reply as recited in the referenced Notice. However, should the undersigned attorney be mistaken, please consider this a petition for any extension of time that may be required to maintain the pendency of this Patent Application, and charge deposit account no. 50-1924 for any required fee deficiency.

To address the Notice of Non-Compliant Amendment, the claim status of claim 19 has been corrected to read "Original" and claim 19 has been removed from the list of amended claims. The remainder of the Amendment as previously submitted on September 21, 2012 remains unchanged and is re-submitted below in its entirety. The Examiner is respectfully requested to consider the amendment for prosecution of the Application towards an Allowance.

AMENDMENTS TO THE CLAIMS:

This listing of the claims will replace all prior versions, and listings, of the claims in this application.

Listing of Claims:

1. (Currently Amended) A method comprising:
 - determining that a set of at least one triggering criterion is met; and
 - providing a power control headroom report on an uplink from user equipment, in response to determining that the set is met, wherein said at least one triggering criterion include [[a]] at least one threshold having been reached, wherein said at least one threshold is adjustable via a signal to the user equipment.

2. (Currently Amended) The method of claim 1, wherein said ~~threshold is adjustable via a signal to the user equipment~~ power control headroom report is for use in a power control correction command to the user equipment.

3. (Currently Amended) The method of claim 1, wherein the set of at least one triggering criterion comprises a triggering criterion such that an absolute difference between current and most recent path-loss measurements has reached a threshold of difference.

4. (Currently Amended) The method of claim 1, wherein said set of at least one triggering criterion include any one of a plurality of criteria that each entail ~~Teaching~~ teaching a respective threshold.

5. (Currently Amended) The method of ~~claim 4~~ claim 1, wherein the ~~plurality~~ set of at least one triggering criterion ~~criteria~~ comprise a first criterion, a second criterion, and a third criterion.

S.N.: 12/665,427
Art Unit: 2618

6. (Currently Amended) The method of claim 1, wherein the set of at least one triggering criterion comprises a criterion ~~such that a number of received~~ being met based on reaching a threshold of the at least one threshold of n closed loop power corrections has reached a threshold of corrections having been received by the user equipment over m transmission time intervals, wherein n and m are integers and wherein said at least one threshold adjustable via the signal comprises adjusting the threshold integers n and m.

7. (Currently Amended) The method of claim 1, wherein the set of at least one triggering criterion comprises a criterion ~~such that an amount of~~ being met based on reaching a threshold of the at least one threshold of m transmission time intervals, following an open loop power control modification, has reached a threshold of intervals since modification, wherein m is an integer and wherein said at least one threshold adjustable via the signal comprises adjusting the threshold integer m.

8. (Currently Amended) The method of claim 1, wherein the set of at least one triggering criterion comprises a criterion ~~such that an amount of~~ being met based on reaching a threshold of the at least one threshold of k transmission time intervals [[,]] following a previous power control headroom report, has reached a threshold of intervals since reporting, wherein k is an integer and wherein said at least one threshold adjustable via the signal comprises adjusting the threshold integer k.

9. (Currently Amended) The method of claim 5, wherein the first criterion is such that a number of received closed loop power corrections has reached a threshold of corrections, and wherein the second criterion is such that an amount of transmission time intervals[[,]] following an open loop power control modification[[,]] has reached a threshold of intervals since modification.

10. (Currently Amended) The method of claim 9, wherein the third criterion is such that an amount of transmission time intervals[[,]] following a previous power control headroom report[[,]] has reached a threshold of intervals since reporting.

11. (Original) The method of claim 9, wherein the third criterion is such that an absolute difference between current and most recent path-loss measurements has reached a threshold of difference.

12. (Currently Amended) An apparatus comprising:

means for determining that a set of at least one triggering criterion is met; and
means for providing a power control headroom report on an uplink from user equipment, in response to the set having been met, wherein said at least one triggering criterion include [[a]] at least one threshold having been reached power correction, wherein said at least one threshold is adjustable via a signal to the apparatus.

13. (Currently Amended) The apparatus of claim 12, wherein said ~~threshold is adjustable via a signal to the user equipment~~ power control headroom report is for use in a power control correction command to the apparatus.

14. (Currently Amended) The apparatus of claim 12, wherein the set of at least one triggering criterion comprises a criterion such that an absolute difference between current and most recent path-loss measurements has reached a threshold of difference.

15. (Original) The apparatus of claim 12, wherein said set of at least one triggering criterion include any one of a plurality of criteria that each entail reaching a respective threshold.

16. (Currently Amended) The apparatus of ~~claim 15~~ claim 12, wherein the ~~plurality~~ set of at least one triggering criteria comprise a first criterion, a second criterion, and a third criterion.

17. (Currently Amended) The apparatus of claim 16, wherein the first criterion is such that a number of received closed loop power corrections has reached a threshold of corrections, and wherein the second criterion is such that an amount of transmission time intervals~~[[,]]~~

S.N.: 12/665,427
Art Unit: 2618

following an open loop power control modification[[,]] has reached a threshold of intervals since modification.

18. (Currently Amended) The apparatus of claim 17, wherein the third criterion is such that an amount of transmission time intervals[[,]] following a previous power control headroom report[[,]] has reached a threshold of intervals since reporting.

19. (Original) The apparatus of claim 17, wherein the third criterion is such that an absolute difference between current and most recent path-loss measurements has reached a threshold of difference.

20. (Currently Amended) ~~Apparatus~~ An apparatus comprising:

at least one processor; and

at least one memory including software, where the at least one memory and the software are configured, with the at least one processor, to cause the apparatus to at least:

~~a triggering module configured to determine that a set of at least one triggering criterion is met; and~~

~~a transceiver configured to provide a power control headroom report on an uplink from said user equipment, in response to the set having been met, wherein said at least one triggering criterion include [[a]] at least one threshold having been reached, wherein said at least one threshold is adjustable via a signal to the apparatus.~~

21. (Currently Amended) The apparatus of claim 20, wherein said ~~threshold is adjustable via a signal to the apparatus~~ power control headroom report is for use in a power control correction command to the apparatus.

S.N.: 12/665,427
Art Unit: 2618

22. (Currently Amended) The apparatus of claim 20, wherein the set of at least one triggering criteria comprises a triggering criterion such that an absolute difference between current and most recent path-loss measurements has reached a threshold of difference.

23. (Original) The apparatus of claim 20, wherein said set of at least one triggering criterion include any one of a plurality of criteria that each entail reaching a respective threshold.

24. (Original) The apparatus of claim 23, wherein the plurality of criteria comprise a first criterion, a second criterion, and a third criterion.

25. (Original) The apparatus of claim 24, wherein the first criterion is such that a number of received closed loop power corrections has reached a threshold of corrections, and wherein the second criterion is such that an amount of transmission time intervals, following an open loop power control modification, has reached a threshold of intervals since modification.

26. (Currently Amended) The apparatus of claim 24, wherein the ~~third~~ second criterion is such that an amount of transmission time intervals[[,]] following a previous power control headroom report[[,]] has reached a threshold of intervals since reporting.

27. (Original) The apparatus of claim 24, wherein the third criterion is such that an absolute difference between current and most recent path-loss measurements has reached a threshold of difference.

28. (Currently Amended) A ~~computer program product comprising a~~ non-transitory computer readable medium including software having executable code stored therein; the code, that when executed by a processor, is adapted to carry out [[the]] functions of:

determining that a set of at least one triggering criterion is met; and

providing a power control headroom report on an uplink from user equipment, in response to the set having been met, wherein said at least one triggering criterion include [[a]]

S.N.: 12/665,427
Art Unit: 2618

at least one threshold having been reached, wherein said at least one threshold is adjustable via a signal to the user equipment.

29. (Currently Amended) The computer ~~program-product~~ readable medium of claim 28, wherein said ~~threshold is adjustable via a signal~~ power control headroom report is for use in a power control correction command to the user equipment.

30. (Currently Amended) The computer ~~program-product~~ readable medium of claim 28, wherein the set comprises a criterion such that an absolute difference between current and most recent path-loss measurements has reached a threshold of difference.

31. (Currently Amended) The computer ~~program-product~~ readable medium of claim 28, wherein said set of at least one triggering criterion include any one of a plurality of criteria that each entail reaching a respective threshold.

32. (Currently Amended) The computer ~~program-product~~ readable medium of claim 31, wherein the plurality of criteria comprise a first criterion, a second criterion, and a third criterion.

33. (Currently Amended) The computer ~~program-product~~ readable medium of claim 32, wherein the first criterion is such that a number of received closed loop power corrections has reached a threshold of corrections, and wherein the second criterion is such that an amount of transmission time intervals, following an open loop power control modification, has reached a threshold of intervals since modification.

34. (Currently Amended) A network element comprising:

at least one processor; and

at least one memory including software, where the at least one memory and the

S.N.: 12/665,427
Art Unit: 2618

software are configured, with the at least one processor, to cause the network element to at least:

~~a report receiving module configured to receive a power control headroom report on an uplink from user equipment, in response to the user equipment determining that a set of at least one triggering criterion is met because [[a]] at least one threshold has been reached, and~~
~~a threshold adjustment module, configured to provide a threshold adjustment signal to the user equipment in order to adjust the at least one threshold.~~

35. (Original) The network element of claim 34, wherein the set comprises a criterion such that an absolute difference between current and most recent path-loss measurements has reached a threshold of difference.

36. (Currently Amended) The network element of claim 34, ~~further comprising a correction module configured~~ wherein the at least one memory including the software is configured with the at least one processor to cause the network element to provide a closed loop power control correction command signal to the user equipment at least partly in response to said power control headroom report.

37. – 39. (Cancelled)

S.N.: 12/665,427
Art Unit: 2618

REMARKS:

This paper is herewith filed in response to the Examiner's Office Action mailed on March 22, 2012 for the above-captioned U.S. Patent Application. This office action is a rejection of claims 1-39 of the application.

More specifically, the Examiner has rejected claims 28-33 under 35 USC 101 asserting that the claimed invention is directed to non-statutory subject matter; rejected claims 1-2, 4-5, 12-13, 15-16, 20-21, 23-24, 28-29, 31-32, 34, and 37 under 35 USC 102(e) as being anticipated by Malladi (US20070270175); rejected claims 3, 14, 22, 30, 35, and 38 under 35 USC 103(a) as being unpatentable over Milladi in view of Milladi (US20100029212) hereafter referred to as Milladi*212; rejected claims 6 and 36 under 35 USC 103(a) as being unpatentable over Milladi in view of Johnson (US20080240013); rejected claim 7 under 35 USC 103(a) as being unpatentable over Milladi in view of Damnjanovic (US20080247358); rejected claim 8 under 35 USC 103(a) as being unpatentable over Milladi in view of Yavuz (US20090034474); rejected claims 9, 17, 25, 33, and 39 under 35 USC 103(a) as being unpatentable over Milladi in view of Johnson and further in view of Damnjanovic; rejected claims 8, 18, and 26 under 35 USC 103(a) as being unpatentable over Malladi in view of Johnson in view of Damnjanovic, and further in view of Yavuz (US20090034474); and rejected claims 11, 19, and 27 under 35 USC 103(a) as being unpatentable over Milladi in view of Johnson in view of Damnjanovic, and further in view of Milladi*212. The rejections are respectfully traversed.

Claims 1-10, 12-14, 17-18, 20-22, 26, 28-34 and 36 have been amended. Claims 37-40 have been cancelled without prejudice or disclaimer. Support for the amendments can be found at least page 6, line 22 to page 7, line 16 and page 8, line 9 to page 9, line 6 of the Application as filed. No new matter is added.

First, regarding the rejection of claims 28-33 under 35 USC 101, these claims have been amended to address the rejection. The Examiner is respectfully requested to remove the rejection under 35 USC 101.

S.N.: 12/665,427
Art Unit: 2618

Regarding the objection to the specification as indicated on page 3 of the Office Action, the claims have been amended to replace the term “computer program product” with the term “software.” This language is at least supported on page 8, lines 22-26 of the Application as filed. For at least these reasons the Examiner is requested to remove the objection to the specification.

In addition, for similar reasons the amendments to apparatus claim 20 and network element claims 34 and 36 are also supported by the specification.

Regarding the Rejection of Independent Claims 1, 12, 20, and 28

Although the rejections are not expressly or impliedly agree with, in order to facilitate the prosecution of this patent application towards allowance each of the Independent claims 1, 12, 20, and 28 have been amended in a somewhat similar fashion to recite features similar to claims 2, 13, 21, and 29, respectively. For example, claim 1 now recites:

A method comprising: determining that a set of at least one triggering criterion is met; and providing a power control headroom report on an uplink from user equipment, in response to determining that the set is met, wherein said at least one triggering criterion include at least one threshold having been reached, wherein said at least one threshold is adjustable via a signal to the user equipment

Regarding the rejection of claim 2, now similarly incorporated in claim 1, the Examiner states:

“Regarding claim 2, Malladi teaches the method of claim 1, wherein said threshold is adjustable via a signal to the user equipment (Paragraph 0025, 0030, and 0097),” (page 4 of the Office Action).

Malladi discloses:

“Systems and methods are provided for mitigating interference in a wireless network by controlling transmitter power levels in the network. In one embodiment, a method for controlling power in a wireless network is provided.

The method includes determining a relative power parameter at a wireless device such as a mobile wireless terminal and receiving a load parameter at the wireless device, where the load parameter is associated with at least one other wireless cell. The method includes adjusting transmit power of the wireless device in view of the relative power parameter and the load parameter. In another embodiment, the transmit power can be controlled in view of an absolute power spectral density parameter. In still yet another embodiment, along with relative power and absolute power spectral density parameters, transmit power can be adjusted in view of a relative power spectral density parameter,” (emphasis added), (paragraph [0025]); and

“In an embodiment, the power control component 160 employs the load indicator bits noted above and another parameter such as power headroom, where such headroom can be a function of a reference signal maintained at the stations 124-130 plus the maximum deliverable power by given devices 144-150. Based on such parameters, power transmissions can be tailored at the transmitting device 144-150 in the cell 124-130 to reduce the impact on devices within the cells or devices associated with other cells. In another embodiment, the power density control component 170 controls the power headroom parameter (or relative transmit power capability) along with a parameter referred to as absolute power spectral density at the devices 144-150. Based on this combination of power headroom and absolute power spectral density, devices 144-150 operating in a given cell 124-130 can adjust a given transmit power output in order to mitigate interference,” (emphasis added), (paragraph [0030]); and

“FIG. 10 is an illustration of a system 1000 for controlling power in accordance with a wireless terminal. In general, the system 1000 is related to a wireless communications apparatus to control transmitted power. This includes a logical component 1002 for receiving load parameters associated with wireless network cells. For example, this could include a receiver circuit in a wireless terminal or other receiver components. At 1004, a logical component is provided for generating a power headroom parameter based on a received reference signal. This could include a processor associated with a wireless terminal. At 1006, a logical component is provided for adjusting power based in part on the load parameters and the power headroom parameter. This can include processor instructions or hardware to execute a power control algorithm for example. At 1008, a logical component is provided for adjusting power based on an absolute power spectral density parameter, where this module can also include components of an algorithm,” (paragraph [0097])

The rejection is vague; however the Examiner appears to assert that the load parameter or load indicator bits or else the reference signal received by the wireless terminal of Milladi is somehow disclosing a signal to adjust a threshold of triggering criterion for a power control headroom

S.N.: 12/665,427
Art Unit: 2618

report at the wireless terminal. First, none of these paragraphs of Malladi disclose any operation using a threshold, for that matter in all of Malladi there is no disclosure of a threshold. Similarly, Malladi does not disclose any operation where these parameters are used to adjust a threshold by the wireless terminal of Malladi. Malladi discloses:

“Thus, one parameter that may be communicated between cells 110-120 indicates the general notion of load in the cell, where a load indicator bit for example, may signal that at least one device 144-150 is communicating in the cell. From these and other parameters, interference can be mitigated between cells 110-120 by employing the parameters to reduce transmit power at the respective devices 144-150 operating within a given cell,” (emphasis added), (paragraph [0029]); and

“In an embodiment, the power control component 160 employs the load indicator bits noted above and another parameter such as power headroom, where such headroom can be a function of a reference signal maintained at the stations 124-130 plus the maximum deliverable power by given devices 144-150. Based on such parameters, power transmissions can be tailored at the transmitting device 144-150 in the cell 124-130 to reduce the impact on devices within the cells or devices associated with other cells. In another embodiment, the power density control component 170 controls the power headroom parameter (or relative transmit power capability) along with a parameter referred to as absolute power spectral density at the devices 144-150. Based on this combination of power headroom and absolute power spectral density, devices 144-150 operating in a given cell 124-130 can adjust a given transmit power output in order to mitigate interference,” (paragraph [0030]).

According to Milladi the load parameter or load indicator bits and the power headroom appear to each be employed to reduce transmit power of the respective devices. However, Malladi does not disclose that the load parameter is used to adjust a threshold of triggering criterion for the power headroom in Malladi. With regards to the reference signal Milladi merely disclose that the power headroom can be a function of the reference signal. Milladi does not disclose any detail regarding this function and Milladi does not disclose that the reference signal somehow adjusts a threshold to trigger the power headroom. For at least these reasons the Examiner is respectfully requested to clarify the support for rejection in a non-final Office Action or else remove the rejection.

The basis for the Examiner's rejection is not understood. The Examiner is respectfully reminded

S.N.: 12/665,427
Art Unit: 2618

that a 35 USC 102 rejection requires that the cited art **disclose to the specificity of the rejected claim**; *Verve, LLC v. Crane Cams, Inc.*, 311 F.3d 1116, 1120, 65 USPQ2d 1051 (Fed. Cir. 2002) (“**A single reference must describe the claimed invention with sufficient precision and detail to establish that the subject matter existed in the prior art**”). It is axiomatic that a 35 USC 102(e) rejection requires strict identity with every claim element.

It is well recognized that "to constitute an anticipation, all material elements recited in a claim must be found in one unit of prior art", *Ex Parte Gould*, BPAI, 6 USPQ 2d, 1680, 1682 (1987), citing with approval *In re Marshall*, 578 F.2d 301, 304, 198 USPQ 344, 346 (CCPA 1978). Clearly, not all material elements recited in claim 1 are found in Malladi as asserted in the anticipation rejection.

Further, none of the references cited overcome at least the above stated shortfalls of Malladi.

Milladi*212

Milladi*212 relates to a method of adjusting transmit power of the wireless device in view of the relative power parameter and the load parameter (paragraph [0025]). Similar to Milladi, as above, in all of Milladi*212 there is not disclosed any operation using a threshold, no less an operation of a received signal adjusting a threshold of triggering criterion for a power control headroom. Milladi*212 does not overcome at least the shortfalls of Milladi as stated above.

Johnson

Johnson discloses a method to perform closed loop power control, a receiving station measures the signal strength of a received signal transmitted from a transmitting station, generates periodic power control commands based on the signal strength measurements, and transmits the periodic power control commands to a transmitting station to control the transmit power level of the transmitting station (Abstract). With regards to the control commands Johnson discloses “To briefly summarize, the base station 20 continuously monitors the uplink load and sends control

S.N.: 12/665,427
Art Unit: 2618

signals to one or more mobile stations 30 to selectively enable and disable compressed mode operation depending on the uplink load,” (paragraph [0016]). The control signals of Johnson used to enable and disable a compressed mode operation does not read on a received signal adjusting a threshold of triggering criterion for a power control headroom. In addition, similar to Malladi and Milladi*212 Johnson does not disclose a received signal adjusting a threshold of triggering criterion for a power control headroom. Johnson does not overcome at least the shortfalls of Milladi and Milladi*212 as stated above.

Damnjanovic

Damnjanovic relates to a method for a channel sensitive scheduler for scheduling transmissions in a communication system *Abstract). Damnjanovic does not disclose a received signal adjusting a threshold of triggering criterion for a power control headroom. Damnjanovic does not overcome at least the shortfalls of Milladi, Milladi*212, and Johnson as stated above.

Yavuz

Yavuz discloses a method for dynamically adjusting the transmission time interval (TTI) for a communications system are presented (Abstract). Yavuz discloses an operation identifying is whether a packet error rate of communications condition is crossing a threshold value however the threshold of Yavuz is predetermined and in a range of 0.1% and 5% (Fig. 5; paragraphs 16 and 18; and claims 18 and 46). Yavuz does not overcome at least the shortfalls of Milladi, Milladi*212, Johnson, and Damnjanovic as stated above.

None of the references cited overcome at least the shortfalls of Milladi as stated above.

For at least these reasons the rejection should be removed and claim 1 should be allowed.

In addition, the Applicants submit that, for similar reasons, the foregoing amendments to the independent claims 12, 20, and 28 also place these claims in condition for allowance in view of

S.N.: 12/665,427
Art Unit: 2618

the references cited. Therefore the Examiner is requested to remove the rejection and allow these claims.

Regarding Independent Claim 34

For at least the reasons stated above none of the references cited disclose or suggest at least where independent claim 34 recites:

“A network element comprising: at least one processor; and at least one memory including software, where the at least one memory and the software are configured, with the at least one processor, to cause the apparatus to at least: receive a power control headroom report on an uplink from user equipment, in response to the user equipment determining that a set of at least one triggering criterion is met because at least one threshold has been reached, and provide a threshold adjustment signal to the user equipment in order to adjust the at least one threshold”

Therefore, the Examiner is requested to remove the rejection and allow claim 34.

Regarding Claim 6

For at least the reasons stated above none of the references cited disclose or suggest at least where claim 6 recites in part:

“wherein the set of at least one triggering criterion comprises a criterion being met based on reaching a threshold of the at least one threshold of n closed loop power corrections having been received by the user equipment over m transmission time intervals, wherein n and m are integers and wherein said at least one threshold adjustable via the signal comprises adjusting the threshold integers n and m.”

Thus, the Examiner is requested to remove the rejection and allow claim 6.

Regarding Claim 7

S.N.: 12/665,427
Art Unit: 2618

For at least the reasons stated above none of the references cited disclose or suggest at least where claim 7 recites in part:

“wherein the set of at least one triggering criterion comprises a criterion being met based on reaching a threshold of the at least one threshold of m transmission time intervals, following an open loop power control modification, wherein m is an integer and wherein said at least one threshold adjustable via the signal comprises adjusting the threshold integer m.”

Therefore, the Examiner is requested to remove the rejection and allow claim 7.

Regarding Claim 8

For at least the reasons stated above none of the references cited disclose or suggest at least where claim 8 recites in part:

“wherein the set of at least one triggering criterion comprises a criterion being met based on reaching a threshold of the at least one threshold of k transmission time intervals following a previous power control headroom report, wherein k is an integer and wherein said at least one threshold adjustable via the signal comprises adjusting the threshold integer k.”

Therefore, the Examiner is requested to remove the rejection and allow claim 8.

In addition, for at least the reasons that claims 2-11, 13-19, 21-27, and 29-33 depend from claims 1, 12, 20, 28, and 34, respectively, the references cited do not disclose or suggest these claims.

Based on the above explanations and arguments, it is clear that the references cited cannot be seen to disclose or suggest claims 1-36. The Examiner is respectfully requested to reconsider and remove the rejections of claims 1-36 and to allow all of the pending claims 1-36 as now presented for examination.

S.N.: 12/665,427
Art Unit: 2618

For all of the foregoing reasons, it is respectfully submitted that all of the claims now present in the application are clearly novel and patentable over the prior art of record. Should any unresolved issue remain, the Examiner is invited to call Applicants' attorney at the telephone number indicated below.

Respectfully submitted:

John A. Garrity
Reg. No.: 60,470

10/15/2012
Date

Customer No.: 29,683

HARRINGTON & SMITH ATTORNEYS AT LAW, LLC

4 Research Drive

Shelton, CT 06484-6212

Telephone: (203)925-9400

Facsimile: (203)944-0245

email: jgarrity@hspatent.com

CERTIFICATE OF MAILING

I hereby certify that this correspondence is being deposited with the United States Postal Service as first class mail in an envelope addressed to: Commissioner for Patents, P.O. BOX 1450, Alexandria, VA 22313-1450.

10/16/2012
Date

Clairine F. Mian
Name of Person Making Deposit

Under the Paperwork Reduction Act of 1995, no persons are required to respond to a collection of information unless it displays a valid OMB control number.

PATENT APPLICATION FEE DETERMINATION RECORD Substitute for Form PTO-875					Application or Docket Number 12/665,427		Filing Date 01/22/2010		<input type="checkbox"/> To be Mailed				
APPLICATION AS FILED – PART I													
(Column 1)			(Column 2)		SMALL ENTITY <input type="checkbox"/>			OR			OTHER THAN SMALL ENTITY		
FOR		NUMBER FILED	NUMBER EXTRA		RATE (\$)	FEE (\$)	OR			RATE (\$)	FEE (\$)		
<input type="checkbox"/> BASIC FEE <small>(37 CFR 1.16(a), (b), or (c))</small>		N/A	N/A		N/A					N/A			
<input type="checkbox"/> SEARCH FEE <small>(37 CFR 1.16(k), (i), or (m))</small>		N/A	N/A		N/A		N/A						
<input type="checkbox"/> EXAMINATION FEE <small>(37 CFR 1.16(o), (p), or (q))</small>		N/A	N/A		N/A		N/A						
TOTAL CLAIMS <small>(37 CFR 1.16(i))</small>		minus 20 =	*		X \$ =		X \$ =						
INDEPENDENT CLAIMS <small>(37 CFR 1.16(h))</small>		minus 3 =	*		X \$ =		X \$ =						
<input type="checkbox"/> APPLICATION SIZE FEE <small>(37 CFR 1.16(s))</small>		If the specification and drawings exceed 100 sheets of paper, the application size fee due is \$250 (\$125 for small entity) for each additional 50 sheets or fraction thereof. See 35 U.S.C. 41(a)(1)(G) and 37 CFR 1.16(s).											
<input type="checkbox"/> MULTIPLE DEPENDENT CLAIM PRESENT <small>(37 CFR 1.16(j))</small>										TOTAL			
* If the difference in column 1 is less than zero, enter "0" in column 2.													
APPLICATION AS AMENDED – PART II										OTHER THAN SMALL ENTITY			
(Column 1)			(Column 2)		SMALL ENTITY			OR			OTHER THAN SMALL ENTITY		
AMENDMENT	10/22/2012		CLAIMS REMAINING AFTER AMENDMENT		HIGHEST NUMBER PREVIOUSLY PAID FOR	PRESENT EXTRA	RATE (\$)	ADDITIONAL FEE (\$)	OR			RATE (\$)	ADDITIONAL FEE (\$)
	Total <small>(37 CFR 1.16(i))</small>		* 36	Minus	** 39	= 0	X \$ =					X \$62=	0
	Independent <small>(37 CFR 1.16(h))</small>		* 5	Minus	***6	= 0	X \$ =		X \$250=	0			
	<input type="checkbox"/> Application Size Fee <small>(37 CFR 1.16(s))</small>												
	<input type="checkbox"/> FIRST PRESENTATION OF MULTIPLE DEPENDENT CLAIM <small>(37 CFR 1.16(j))</small>												
							TOTAL ADD'L FEE		OR			TOTAL ADD'L FEE	
									OR			0	
AMENDMENT			CLAIMS REMAINING AFTER AMENDMENT		HIGHEST NUMBER PREVIOUSLY PAID FOR	PRESENT EXTRA	RATE (\$)	ADDITIONAL FEE (\$)	OR			RATE (\$)	ADDITIONAL FEE (\$)
	Total <small>(37 CFR 1.16(i))</small>		*	Minus	**	=	X \$ =					X \$ =	
	Independent <small>(37 CFR 1.16(h))</small>		*	Minus	***	=	X \$ =		X \$ =				
	<input type="checkbox"/> Application Size Fee <small>(37 CFR 1.16(s))</small>												
	<input type="checkbox"/> FIRST PRESENTATION OF MULTIPLE DEPENDENT CLAIM <small>(37 CFR 1.16(j))</small>												
							TOTAL ADD'L FEE		OR			TOTAL ADD'L FEE	
									OR				
* If the entry in column 1 is less than the entry in column 2, write "0" in column 3.													
** If the "Highest Number Previously Paid For" IN THIS SPACE is less than 20, enter "20".													
*** If the "Highest Number Previously Paid For" IN THIS SPACE is less than 3, enter "3".													
The "Highest Number Previously Paid For" (Total or Independent) is the highest number found in the appropriate box in column 1.													
										Legal Instrument Examiner: /KIM P. DOZIER/			

This collection of information is required by 37 CFR 1.16. The information is required to obtain or retain a benefit by the public which is to file (and by the USPTO to process) an application. Confidentiality is governed by 35 U.S.C. 122 and 37 CFR 1.14. This collection is estimated to take 12 minutes to complete, including gathering, preparing, and submitting the completed application form to the USPTO. Time will vary depending upon the individual case. Any comments on the amount of time you require to complete this form and/or suggestions for reducing this burden, should be sent to the Chief Information Officer, U.S. Patent and Trademark Office, U.S. Department of Commerce, P.O. Box 1450, Alexandria, VA 22313-1450. DO NOT SEND FEES OR COMPLETED FORMS TO THIS ADDRESS. **SEND TO: Commissioner for Patents, P.O. Box 1450, Alexandria, VA 22313-1450.**

If you need assistance in completing the form, call 1-800-PTO-9199 and select option 2.



UNITED STATES DEPARTMENT OF COMMERCE
United States Patent and Trademark Office
Address: COMMISSIONER FOR PATENTS
P.O. Box 1450
Alexandria, Virginia 22313-1450
www.uspto.gov

NOTICE OF ALLOWANCE AND FEE(S) DUE

29683 7590 01/18/2013
HARRINGTON & SMITH
4 RESEARCH DRIVE, Suite 202
SHELTON, CT 06484-6212

EXAMINER

REGO, DOMINIC E

ART UNIT PAPER NUMBER

2647

DATE MAILED: 01/18/2013

Table with 5 columns: APPLICATION NO., FILING DATE, FIRST NAMED INVENTOR, ATTORNEY DOCKET NO., CONFIRMATION NO.

12/665,427 01/22/2010 Juergen Michel 863.0156.U1(US) 1011

TITLE OF INVENTION: Power Headroom Reporting Method

Table with 7 columns: APPLN. TYPE, SMALL ENTITY, ISSUE FEE DUE, PUBLICATION FEE DUE, PREV. PAID ISSUE FEE, TOTAL FEE(S) DUE, DATE DUE

nonprovisional NO \$1770 \$300 \$0 \$2070 04/18/2013

THE APPLICATION IDENTIFIED ABOVE HAS BEEN EXAMINED AND IS ALLOWED FOR ISSUANCE AS A PATENT. PROSECUTION ON THE MERITS IS CLOSED. THIS NOTICE OF ALLOWANCE IS NOT A GRANT OF PATENT RIGHTS. THIS APPLICATION IS SUBJECT TO WITHDRAWAL FROM ISSUE AT THE INITIATIVE OF THE OFFICE OR UPON PETITION BY THE APPLICANT. SEE 37 CFR 1.313 AND MPEP 1308.

THE ISSUE FEE AND PUBLICATION FEE (IF REQUIRED) MUST BE PAID WITHIN THREE MONTHS FROM THE MAILING DATE OF THIS NOTICE OR THIS APPLICATION SHALL BE REGARDED AS ABANDONED. THIS STATUTORY PERIOD CANNOT BE EXTENDED. SEE 35 U.S.C. 151. THE ISSUE FEE DUE INDICATED ABOVE DOES NOT REFLECT A CREDIT FOR ANY PREVIOUSLY PAID ISSUE FEE IN THIS APPLICATION. IF AN ISSUE FEE HAS PREVIOUSLY BEEN PAID IN THIS APPLICATION (AS SHOWN ABOVE), THE RETURN OF PART B OF THIS FORM WILL BE CONSIDERED A REQUEST TO REAPPLY THE PREVIOUSLY PAID ISSUE FEE TOWARD THE ISSUE FEE NOW DUE.

HOW TO REPLY TO THIS NOTICE:

I. Review the SMALL ENTITY status shown above.

If the SMALL ENTITY is shown as YES, verify your current SMALL ENTITY status:

- A. If the status is the same, pay the TOTAL FEE(S) DUE shown above.
B. If the status above is to be removed, check box 5b on Part B - Fee(s) Transmittal and pay the PUBLICATION FEE (if required) and twice the amount of the ISSUE FEE shown above, or

If the SMALL ENTITY is shown as NO:

- A. Pay TOTAL FEE(S) DUE shown above, or
B. If applicant claimed SMALL ENTITY status before, or is now claiming SMALL ENTITY status, check box 5a on Part B - Fee(s) Transmittal and pay the PUBLICATION FEE (if required) and 1/2 the ISSUE FEE shown above.

II. PART B - FEE(S) TRANSMITTAL, or its equivalent, must be completed and returned to the United States Patent and Trademark Office (USPTO) with your ISSUE FEE and PUBLICATION FEE (if required). If you are charging the fee(s) to your deposit account, section "4b" of Part B - Fee(s) Transmittal should be completed and an extra copy of the form should be submitted. If an equivalent of Part B is filed, a request to reapply a previously paid issue fee must be clearly made, and delays in processing may occur due to the difficulty in recognizing the paper as an equivalent of Part B.

III. All communications regarding this application must give the application number. Please direct all communications prior to issuance to Mail Stop ISSUE FEE unless advised to the contrary.

IMPORTANT REMINDER: Utility patents issuing on applications filed on or after Dec. 12, 1980 may require payment of maintenance fees. It is patentee's responsibility to ensure timely payment of maintenance fees when due.

PART B - FEE(S) TRANSMITTAL

**Complete and send this form, together with applicable fee(s), to: Mail Mail Stop ISSUE FEE
 Commissioner for Patents
 P.O. Box 1450
 Alexandria, Virginia 22313-1450
 or Fax (571)-273-2885**

INSTRUCTIONS: This form should be used for transmitting the ISSUE FEE and PUBLICATION FEE (if required). Blocks 1 through 5 should be completed where appropriate. All further correspondence including the Patent, advance orders and notification of maintenance fees will be mailed to the current correspondence address as indicated unless corrected below or directed otherwise in Block 1, by (a) specifying a new correspondence address; and/or (b) indicating a separate "FEE ADDRESS" for maintenance fee notifications.

CURRENT CORRESPONDENCE ADDRESS (Note: Use Block 1 for any change of address)

Note: A certificate of mailing can only be used for domestic mailings of the Fee(s) Transmittal. This certificate cannot be used for any other accompanying papers. Each additional paper, such as an assignment or formal drawing, must have its own certificate of mailing or transmission.

29683 7590 01/18/2013

HARRINGTON & SMITH
 4 RESEARCH DRIVE, Suite 202
 SHELTON, CT 06484-6212

Certificate of Mailing or Transmission

I hereby certify that this Fee(s) Transmittal is being deposited with the United States Postal Service with sufficient postage for first class mail in an envelope addressed to the Mail Stop ISSUE FEE address above, or being facsimile transmitted to the USPTO (571) 273-2885, on the date indicated below.

_____ (Depositor's name)
_____ (Signature)
_____ (Date)

APPLICATION NO.	FILING DATE	FIRST NAMED INVENTOR	ATTORNEY DOCKET NO.	CONFIRMATION NO.
12/665,427	01/22/2010	Juergen Michel	863.0156.U1(US)	1011

TITLE OF INVENTION: Power Headroom Reporting Method

APPLN. TYPE	SMALL ENTITY	ISSUE FEE DUE	PUBLICATION FEE DUE	PREV. PAID ISSUE FEE	TOTAL FEE(S) DUE	DATE DUE
nonprovisional	NO	\$1770	\$300	\$0	\$2070	04/18/2013

EXAMINER	ART UNIT	CLASS-SUBCLASS
REGO, DOMINIC E	2647	455-522000

<p>1. Change of correspondence address or indication of "Fee Address" (37 CFR 1.363).</p> <p><input type="checkbox"/> Change of correspondence address (or Change of Correspondence Address form PTO/SB/122) attached.</p> <p><input type="checkbox"/> "Fee Address" indication (or "Fee Address" Indication form PTO/SB/47; Rev 03-02 or more recent) attached. Use of a Customer Number is required.</p>	<p>2. For printing on the patent front page, list</p> <p>(1) the names of up to 3 registered patent attorneys or agents OR, alternatively, _____ 1</p> <p>(2) the name of a single firm (having as a member a registered attorney or agent) and the names of up to 2 registered patent attorneys or agents. If no name is listed, no name will be printed. _____ 2</p> <p>_____ 3</p>
-------------------------------------------------------------------------------------------------------------------------------------------------------------------------------------------------------------------------------------------------------------------------------------------------------------------------------------------------------------------------------------------------------------------	---------------------------------------------------------------------------------------------------------------------------------------------------------------------------------------------------------------------------------------------------------------------------------------------------------------------------------------------------------------------------------------

3. ASSIGNEE NAME AND RESIDENCE DATA TO BE PRINTED ON THE PATENT (print or type)

PLEASE NOTE: Unless an assignee is identified below, no assignee data will appear on the patent. If an assignee is identified below, the document has been filed for recordation as set forth in 37 CFR 3.11. Completion of this form is NOT a substitute for filing an assignment.

(A) NAME OF ASSIGNEE _____ (B) RESIDENCE: (CITY and STATE OR COUNTRY) _____

Please check the appropriate assignee category or categories (will not be printed on the patent): Individual Corporation or other private group entity Government

<p>4a. The following fee(s) are submitted:</p> <p><input type="checkbox"/> Issue Fee</p> <p><input type="checkbox"/> Publication Fee (No small entity discount permitted)</p> <p><input type="checkbox"/> Advance Order - # of Copies _____</p>	<p>4b. Payment of Fee(s): (Please first reapply any previously paid issue fee shown above)</p> <p><input type="checkbox"/> A check is enclosed.</p> <p><input type="checkbox"/> Payment by credit card. Form PTO-2038 is attached.</p> <p><input type="checkbox"/> The Director is hereby authorized to charge the required fee(s), any deficiency, or credit any overpayment, to Deposit Account Number _____ (enclose an extra copy of this form).</p>
-------------------------------------------------------------------------------------------------------------------------------------------------------------------------------------------------------------------------------------------------	----------------------------------------------------------------------------------------------------------------------------------------------------------------------------------------------------------------------------------------------------------------------------------------------------------------------------------------------------------------------------------------------------------------------------------------------------------

5. Change in Entity Status (from status indicated above)

a. Applicant claims SMALL ENTITY status. See 37 CFR 1.27. b. Applicant is no longer claiming SMALL ENTITY status. See 37 CFR 1.27(g)(2).

NOTE: The Issue Fee and Publication Fee (if required) will not be accepted from anyone other than the applicant; a registered attorney or agent; or the assignee or other party in interest as shown by the records of the United States Patent and Trademark Office.

Authorized Signature _____ Date _____

Typed or printed name _____ Registration No. _____

This collection of information is required by 37 CFR 1.311. The information is required to obtain or retain a benefit by the public which is to file (and by the USPTO to process) an application. Confidentiality is governed by 35 U.S.C. 122 and 37 CFR 1.14. This collection is estimated to take 12 minutes to complete, including gathering, preparing, and submitting the completed application form to the USPTO. Time will vary depending upon the individual case. Any comments on the amount of time you require to complete this form and/or suggestions for reducing this burden, should be sent to the Chief Information Officer, U.S. Patent and Trademark Office, U.S. Department of Commerce, P.O. Box 1450, Alexandria, Virginia 22313-1450. DO NOT SEND FEES OR COMPLETED FORMS TO THIS ADDRESS. SEND TO: Commissioner for Patents, P.O. Box 1450, Alexandria, Virginia 22313-1450.

Under the Paperwork Reduction Act of 1995, no persons are required to respond to a collection of information unless it displays a valid OMB control number.



UNITED STATES PATENT AND TRADEMARK OFFICE

UNITED STATES DEPARTMENT OF COMMERCE
United States Patent and Trademark Office
Address: COMMISSIONER FOR PATENTS
P.O. Box 1450
Alexandria, Virginia 22313-1450
www.uspto.gov

Table with 5 columns: APPLICATION NO., FILING DATE, FIRST NAMED INVENTOR, ATTORNEY DOCKET NO., CONFIRMATION NO.
Row 1: 12/665,427, 01/22/2010, Juergen Michel, 863.0156.U1(US), 1011
Row 2: 29683, 7590, 01/18/2013, [Empty], [Empty]
Row 3: HARRINGTON & SMITH, 4 RESEARCH DRIVE, Suite 202, SHELTON, CT 06484-6212, [Empty], [Empty]
Row 4: [Empty], [Empty], [Empty], ART UNIT, PAPER NUMBER

DATE MAILED: 01/18/2013

Determination of Patent Term Adjustment under 35 U.S.C. 154 (b)
(application filed on or after May 29, 2000)

The Patent Term Adjustment to date is 244 day(s). If the issue fee is paid on the date that is three months after the mailing date of this notice and the patent issues on the Tuesday before the date that is 28 weeks (six and a half months) after the mailing date of this notice, the Patent Term Adjustment will be 244 day(s).

If a Continued Prosecution Application (CPA) was filed in the above-identified application, the filing date that determines Patent Term Adjustment is the filing date of the most recent CPA.

Applicant will be able to obtain more detailed information by accessing the Patent Application Information Retrieval (PAIR) WEB site (http://pair.uspto.gov).

Any questions regarding the Patent Term Extension or Adjustment determination should be directed to the Office of Patent Legal Administration at (571)-272-7702. Questions relating to issue and publication fee payments should be directed to the Customer Service Center of the Office of Patent Publication at 1-(888)-786-0101 or (571)-272-4200.

Privacy Act Statement

The Privacy Act of 1974 (P.L. 93-579) requires that you be given certain information in connection with your submission of the attached form related to a patent application or patent. Accordingly, pursuant to the requirements of the Act, please be advised that: (1) the general authority for the collection of this information is 35 U.S.C. 2(b)(2); (2) furnishing of the information solicited is voluntary; and (3) the principal purpose for which the information is used by the U.S. Patent and Trademark Office is to process and/or examine your submission related to a patent application or patent. If you do not furnish the requested information, the U.S. Patent and Trademark Office may not be able to process and/or examine your submission, which may result in termination of proceedings or abandonment of the application or expiration of the patent.

The information provided by you in this form will be subject to the following routine uses:

1. The information on this form will be treated confidentially to the extent allowed under the Freedom of Information Act (5 U.S.C. 552) and the Privacy Act (5 U.S.C. 552a). Records from this system of records may be disclosed to the Department of Justice to determine whether disclosure of these records is required by the Freedom of Information Act.
2. A record from this system of records may be disclosed, as a routine use, in the course of presenting evidence to a court, magistrate, or administrative tribunal, including disclosures to opposing counsel in the course of settlement negotiations.
3. A record in this system of records may be disclosed, as a routine use, to a Member of Congress submitting a request involving an individual, to whom the record pertains, when the individual has requested assistance from the Member with respect to the subject matter of the record.
4. A record in this system of records may be disclosed, as a routine use, to a contractor of the Agency having need for the information in order to perform a contract. Recipients of information shall be required to comply with the requirements of the Privacy Act of 1974, as amended, pursuant to 5 U.S.C. 552a(m).
5. A record related to an International Application filed under the Patent Cooperation Treaty in this system of records may be disclosed, as a routine use, to the International Bureau of the World Intellectual Property Organization, pursuant to the Patent Cooperation Treaty.
6. A record in this system of records may be disclosed, as a routine use, to another federal agency for purposes of National Security review (35 U.S.C. 181) and for review pursuant to the Atomic Energy Act (42 U.S.C. 218(c)).
7. A record from this system of records may be disclosed, as a routine use, to the Administrator, General Services, or his/her designee, during an inspection of records conducted by GSA as part of that agency's responsibility to recommend improvements in records management practices and programs, under authority of 44 U.S.C. 2904 and 2906. Such disclosure shall be made in accordance with the GSA regulations governing inspection of records for this purpose, and any other relevant (i.e., GSA or Commerce) directive. Such disclosure shall not be used to make determinations about individuals.
8. A record from this system of records may be disclosed, as a routine use, to the public after either publication of the application pursuant to 35 U.S.C. 122(b) or issuance of a patent pursuant to 35 U.S.C. 151. Further, a record may be disclosed, subject to the limitations of 37 CFR 1.14, as a routine use, to the public if the record was filed in an application which became abandoned or in which the proceedings were terminated and which application is referenced by either a published application, an application open to public inspection or an issued patent.
9. A record from this system of records may be disclosed, as a routine use, to a Federal, State, or local law enforcement agency, if the USPTO becomes aware of a violation or potential violation of law or regulation.

Notice of Allowability	Application No.	Applicant(s)	
	12/665,427	MICHEL ET AL.	
	Examiner	Art Unit	
	DOMINIC E. REGO	2647	

-- The MAILING DATE of this communication appears on the cover sheet with the correspondence address--

All claims being allowable, PROSECUTION ON THE MERITS IS (OR REMAINS) CLOSED in this application. If not included herewith (or previously mailed), a Notice of Allowance (PTOL-85) or other appropriate communication will be mailed in due course. **THIS NOTICE OF ALLOWABILITY IS NOT A GRANT OF PATENT RIGHTS.** This application is subject to withdrawal from issue at the initiative of the Office or upon petition by the applicant. See 37 CFR 1.313 and MPEP 1308.

1. This communication is responsive to 10/22/2012.
2. An election was made by the applicant in response to a restriction requirement set forth during the interview on _____; the restriction requirement and election have been incorporated into this action.
3. The allowed claim(s) is/are 1-7 and 9-35. As a result of the allowed claim(s), you may be eligible to benefit from the **Patent Prosecution Highway** program at a participating intellectual property office for the corresponding application. For more information, please see http://www.uspto.gov/patents/init_events/pph/index.jsp or send an inquiry to PPHfeedback@uspto.gov.
4. Acknowledgment is made of a claim for foreign priority under 35 U.S.C. § 119(a)-(d) or (f).
 - a) All b) Some* c) None of the:
 1. Certified copies of the priority documents have been received.
 2. Certified copies of the priority documents have been received in Application No. _____.
 3. Copies of the certified copies of the priority documents have been received in this national stage application from the International Bureau (PCT Rule 17.2(a)).

* Certified copies not received: _____.

Applicant has THREE MONTHS FROM THE "MAILING DATE" of this communication to file a reply complying with the requirements noted below. Failure to timely comply will result in ABANDONMENT of this application.

THIS THREE-MONTH PERIOD IS NOT EXTENDABLE.

5. CORRECTED DRAWINGS (as "replacement sheets") must be submitted.
 - including changes required by the attached Examiner's Amendment / Comment or in the Office action of Paper No./Mail Date _____.

Identifying indicia such as the application number (see 37 CFR 1.84(c)) should be written on the drawings in the front (not the back) of each sheet. Replacement sheet(s) should be labeled as such in the header according to 37 CFR 1.121(d).
6. DEPOSIT OF and/or INFORMATION about the deposit of BIOLOGICAL MATERIAL must be submitted. Note the attached Examiner's comment regarding REQUIREMENT FOR THE DEPOSIT OF BIOLOGICAL MATERIAL.

Attachment(s)

- | | |
|------------------------------------------------------------------------------------------------------------|--------------------------------------------------------------------------------------|
| 1. <input type="checkbox"/> Notice of References Cited (PTO-892) | 5. <input checked="" type="checkbox"/> Examiner's Amendment/Comment |
| 2. <input type="checkbox"/> Information Disclosure Statements (PTO/SB/08),
Paper No./Mail Date _____ | 6. <input checked="" type="checkbox"/> Examiner's Statement of Reasons for Allowance |
| 3. <input type="checkbox"/> Examiner's Comment Regarding Requirement for Deposit
of Biological Material | 7. <input type="checkbox"/> Other _____. |
| 4. <input checked="" type="checkbox"/> Interview Summary (PTO-413),
Paper No./Mail Date _____. | |

--	--

Examiner-Initiated Interview Summary	Application No. 12/665,427	Applicant(s) MICHEL ET AL.	
	Examiner DOMINIC E. REGO	Art Unit 2647	

All participants (applicant, applicant's representative, PTO personnel):

(1) DOMINIC E. REGO. (3)_____.

(2) John A. Garrity, Reg. No. 60,470. (4)_____.

Date of Interview: 09 January 2013.

Type: Telephonic Video Conference
 Personal [copy given to: applicant applicant's representative]

Exhibit shown or demonstration conducted: Yes No.

If Yes, brief description: _____.

Issues Discussed 101 112 102 103 Others

(For each of the checked box(es) above, please describe below the issue and detailed description of the discussion)

Claim(s) discussed: 8.

Identification of prior art discussed: N/A.

Substance of Interview

(For each issue discussed, provide a detailed description and indicate if agreement was reached. Some topics may include: identification or clarification of a reference or a portion thereof, claim interpretation, proposed amendments, arguments of any applied references etc...)

Agreed to add allowable claim 8 to independent claims 1, 12, 20, 28, and 34.

Applicant recordation instructions: It is not necessary for applicant to provide a separate record of the substance of interview.

Examiner recordation instructions: Examiners must summarize the substance of any interview of record. A complete and proper recordation of the substance of an interview should include the items listed in MPEP 713.04 for complete and proper recordation including the identification of the general thrust of each argument or issue discussed, a general indication of any other pertinent matters discussed regarding patentability and the general results or outcome of the interview, to include an indication as to whether or not agreement was reached on the issues raised.

Attachment

/DOMINIC E REGO/
Primary Examiner, Art Unit 2647

DETAILED ACTION

EXAMINER'S AMENDMENT

1. An examiner's amendment to the record appears below. Should the changes and/or additions be unacceptable to applicant, an amendment may be filed as provided by 37 CFR 1.312. To ensure consideration of such an amendment, it MUST be submitted no later than the payment of the issue fee.

Authorization for this examiner's amendment was given in a telephone interview with John A. Garrity on 01/12/2013.

The application has been amended as follows:

1. (Currently Amended) A method comprising:
determining that a set of at least one triggering criterion is met; and
providing a power control headroom report on an uplink from user equipment, in response to determining that the set is met, wherein said at least one triggering criterion include at least one threshold having been reached, wherein said at least one threshold is adjustable via a signal to the user equipment, wherein the set of at least one triggering criterion comprises a criterion being met based on reaching a threshold of the at least one threshold of k transmission time intervals following a previous power control headroom report, wherein k is an integer and wherein said at least one threshold adjustable via the signal comprises adjusting the threshold integer k.

8. (Cancelled)

12. (Currently Amended) An apparatus comprising:

means for determining that a set of at least one triggering criterion is met; and
means for providing a power control headroom report on an uplink from user equipment, in response to the set having been met, wherein said at least one triggering criterion include at least one threshold having been reached power correction, wherein said at least one threshold is adjustable via a signal to the apparatus, wherein the set of at least one triggering criterion comprises a criterion being met based on reaching a threshold of the at least one threshold of k transmission time intervals following a previous power control headroom report, wherein k is an integer and wherein said at least one threshold adjustable via the signal comprises adjusting the threshold integer k.

20. (Currently Amended) An apparatus comprising:

at least one processor; and
at least one memory including software, where the at least one memory and the software are configured, with the at least one processor, to cause the apparatus to at least:
determine that a set of at least one triggering criterion is met; and
provide a power control headroom report on an uplink from said user equipment, in response to the set having been met, wherein said at least one triggering criterion include at least one threshold having been reached, wherein said at least one threshold

is adjustable via a signal to the apparatus, wherein the set of at least one triggering criterion comprises a criterion being met based on reaching a threshold of the at least one threshold of k transmission time intervals following a previous power control headroom report, wherein k is an integer and wherein said at least one threshold adjustable via the signal comprises adjusting the threshold integer k.

28. (Currently Amended) A non-transitory computer readable medium including software that when executed by a processor, is adapted to carry out functions of:

- determining that a set of at least one triggering criterion is met; and
- providing a power control headroom report on an uplink from user equipment, in response to the set having been met, wherein said at least one triggering criterion include at least one threshold having been reached, wherein said at least one threshold is adjustable via a signal to the user equipment, wherein the set of at least one triggering criterion comprises a criterion being met based on reaching a threshold of the at least one threshold of k transmission time intervals following a previous power control headroom report, wherein k is an integer and wherein said at least one threshold adjustable via the signal comprises adjusting the threshold integer k.

34. (Currently Amended) A network element comprising:

- at least one processor; and
- at least one memory including software, where the at least one memory and the software are configured, with the at least one processor, to cause the network element

to at least:

receive a power control headroom report on an uplink from user equipment, in response to the user equipment determining that a set of at least one triggering criterion is met because at least one threshold has been reached, wherein the set of at least one triggering criterion comprises a criterion being met based on reaching a threshold of the at least one threshold of k transmission time intervals following a previous power control headroom report, wherein k is an integer and wherein said at least one threshold adjustable via the signal comprises adjusting the threshold integer k; and

provide a threshold adjustment signal to the user equipment in order to adjust the at least one threshold.

37. – 39. (Cancelled)

(End of Amendment).

Allowable Subject Matter

2. Claims 1-7 and 9-36 are allowed.

3. The following is an examiner's statement of reasons for allowance:

Regarding claims 1, 12, 20, 28, and 34, the prior art of record fails to teach wherein the set of at least one triggering criterion comprises a criterion being met based on reaching a threshold of the at least one threshold of k transmission time intervals

following a previous power control headroom report, wherein k is an integer and wherein said at least one threshold adjustable via the signal comprises adjusting the threshold integer k.

Dependent claims 2-7, 9-11, 13-19, 21-27, 29-33, 35, and 36 are allowed for the same reason.

Any comments considered necessary by applicant must be submitted no later than the payment of the issue fee and, to avoid processing delays, should preferably accompany the issue fee. Such submissions should be clearly labeled "Comments on Statement of Reasons for Allowance."

Conclusion

Any inquiry concerning this communication or earlier communications from the examiner should be directed to DOMINIC E. REGO whose telephone number is (571)272-8132. The examiner can normally be reached on Monday-Friday, 9:00 am-5:30 pm.

If attempts to reach the examiner by telephone are unsuccessful, the examiner's supervisor, Andrew Wendell can be reached on 571-272-0557. The fax phone number for the organization where this application or proceeding is assigned is 571-273-8300.

Art Unit: 2647

Information regarding the status of an application may be obtained from the Patent Application Information Retrieval (PAIR) system. Status information for published applications may be obtained from either Private PAIR or Public PAIR. Status information for unpublished applications is available through Private PAIR only. For more information about the PAIR system, see <http://pair-direct.uspto.gov>. Should you have questions on access to the Private PAIR system, contact the Electronic Business Center (EBC) at 866-217-9197 (toll-free). If you would like assistance from a USPTO Customer Service Representative or access to the automated information system, call 800-786-9199 (IN USA OR CANADA) or 571-272-1000.

/DOMINIC E REGO/
Primary Examiner, Art Unit 2647
Tel 571-272-8132

Search Notes 	Application/Control No. 12665427	Applicant(s)/Patent Under Reexamination MICHEL ET AL.
	Examiner DOMINIC E REGO	Art Unit 2618

SEARCHED			
Class	Subclass	Date	Examiner
455	522, 67.11, 68-70, 115.3, 126, 127.1, 127.2, 135, 226.3, 277.2, 296	3/15/2012	DR
370	318	3/15/2012	DR

SEARCH NOTES		
Search Notes	Date	Examiner
EAST, Inventor, and Assignee Search	3/15/2012	DR
Updated EAST, Inventor, and Assignee Search	1/12/2013	DR

INTERFERENCE SEARCH			
Class	Subclass	Date	Examiner
	PGPUB Text Search-See Interference Search History	1/12/2013	DR

--	--

EAST Search History

EAST Search History (Prior Art)

Ref #	Hits	Search Query	DBs	Default Operator	Plurals	Time Stamp
L16	21460	455/522,67.11,68-70,115.3,126,127.1,127.2,135,226.3,277.2,296.ccls.370/318.ccls.	US-PGPUB; USPAT; USOCR; FPRS; EPO; JPO	OR	ON	2013/01/13 00:25
L17	9	power near2 control\$4 with report\$3 same adjust\$3 near4 threshold	US-PGPUB; USPAT; USOCR; FPRS; EPO; JPO	OR	ON	2013/01/13 00:26
L18	61	power near2 control\$4 near4 report\$3 same (increase\$3 rais\$3 adjust\$3 revis\$3 higher more most maximum max maximal larger exceed\$3 greater increment\$3 decreas\$3 lower\$3 reduc\$4 diminish\$3 lessen\$3 mitigat\$3 suppress\$3 attenuat\$3 degrad\$3 decrement\$3) near2 threshold	US-PGPUB; USPAT; USOCR; FPRS; EPO; JPO	OR	ON	2013/01/13 00:26
L19	24	16 and 18	US-PGPUB; USPAT; USOCR; FPRS; EPO; JPO	OR	ON	2013/01/13 00:26
L20	22	19 and (@ad <= "20070620" @rlad <= "20070620" @pd <= "20070620")	US-PGPUB; USPAT; USOCR; FPRS; EPO; JPO	OR	ON	2013/01/13 00:27
L21	65	power near2 control\$4 near4 report\$3 same (increase\$3 rais\$3 adjust\$3 revis\$3 higher more most maximum max maximal larger exceed\$3 greater increment\$3 decreas\$3 lower\$3 reduc\$4 diminish\$3 lessen\$3 mitigat\$3 suppress\$3 attenuat\$3 degrad\$3 decrement\$3 reach\$3) near2 threshold	US-PGPUB; USPAT; USOCR; FPRS; EPO; JPO	OR	ON	2013/01/13 00:28
L22	33	21 same (cellular cell adj phone mobile portable pda terminal device user equipment (wireless communication) near2 (terminal device unit apparatus station user subscriber phone cellular cell adj phone mobile equipment) phone telephone cordless hand\$free hand adj free hand\$held hand adj held wtru subscriber station\$1 electronic near2 (device station terminal unit) apparatus)	US-PGPUB; USPAT; USOCR; FPRS; EPO; JPO	OR	ON	2013/01/13 00:29

EAST Search History

L23	25	22 same (cell network sector cell base adj2 stations bts\$1 bs\$1 base\$station node-b access near point ap base near2 site bss bs)	US-PGPUB; USPAT; USOCR; FPRS; EPO; JPO	OR	ON	2013/01/13 00:30
L24	22	16 and 23	US-PGPUB; USPAT; USOCR; FPRS; EPO; JPO	OR	ON	2013/01/13 00:32
L25	29	22 and (@ad <= "20070620" @rlad <= "20070620" @pd <= "20070620")	US-PGPUB; USPAT; USOCR; FPRS; EPO; JPO	OR	ON	2013/01/13 00:32
L26	21	24 and (@ad <= "20070620" @rlad <= "20070620" @pd <= "20070620")	US-PGPUB; USPAT; USOCR; FPRS; EPO; JPO	OR	ON	2013/01/13 00:32
L27	5	power near2 control\$4 near4 report\$3 same (rais\$3 adjust\$3 reach\$3) near2 threshold	US-PGPUB; USPAT; USOCR; FPRS; EPO; JPO	OR	ON	2013/01/13 00:33
S50	1	power near2 control\$4 near4 report\$3 same adjust\$3 near4 threshold	US-PGPUB; USPAT; USOCR; FPRS; EPO; JPO	OR	ON	2013/01/09 06:41
S51	185	power near2 control\$4 with report\$3 same (increase\$3 rais\$3 adjust\$3 revis\$3 higher more most maximum max maximal larger exceed\$3 greater increment\$3 decreas\$3 lower\$3 reduc\$4 diminish\$3 lessen\$3 mitigat\$3 suppress\$3 attenuat\$3 degrad\$3 decrement\$3) near4 threshold	US-PGPUB; USPAT; USOCR; FPRS; EPO; JPO	OR	ON	2013/01/09 06:46
S52	124	S51 and (@ad <= "20070620" @rlad <= "20070620" @pd <= "20070620")	US-PGPUB; USPAT; USOCR; FPRS; EPO; JPO	OR	ON	2013/01/09 06:46
S53	4	S51 same (open\$loop open near loop outer\$loop outer near loop)	US-PGPUB; USPAT; USOCR; FPRS;	OR	ON	2013/01/09 06:47

EAST Search History

			EPO; JPO			
S54	4	S51 same (open\$loop open near loop outer\$loop outer near loop close\$loop close near loop inner\$loop inner near loop)	US- PGPUB; USPAT; USOCR; FPRS; EPO; JPO	OR	ON	2013/01/09 06:48
S55	2	S54 and (@ad <= "20070620" @rlad <= "20070620" @pd <= "20070620")	US- PGPUB; USPAT; USOCR; FPRS; EPO; JPO	OR	ON	2013/01/09 06:48
S56	9	power near2 control\$4 with report\$3 same adjust\$3 near4 threshold	US- PGPUB; USPAT; USOCR; FPRS; EPO; JPO	OR	ON	2013/01/09 06:51
S57	8	S56 and (@ad <= "20070620" @rlad <= "20070620" @pd <= "20070620")	US- PGPUB; USPAT; USOCR; FPRS; EPO; JPO	OR	ON	2013/01/09 06:52

1/ 13/ 2013 12:36:05 AM

C:\Users\drego\Documents\EAST\Workspaces\12665427.wsp

EAST Search History

EAST Search History (Prior Art)

Ref #	Hits	Search Query	DBs	Default Operator	Plurals	Time Stamp
L5	293	(juergen near2 michel).in. (klaus near2 ingemann near2 pedersen).in. (claudio near rosa).in.	US-PGPUB; USPAT; USOCR; FPRS; EPO; JPO	OR	ON	2013/01/13 00:16
L6	30081	nokia.as.	US-PGPUB; USPAT; USOCR; FPRS; EPO; JPO	OR	ON	2013/01/13 00:16
L7	308	(power near2 head\$room).clm.	US-PGPUB; USPAT; USOCR; FPRS; EPO; JPO	OR	ON	2013/01/13 00:16
L8	5	(power near2 control\$4 with report\$3 same adjust\$3 near4 threshold).clm.	US-PGPUB; USPAT; USOCR; FPRS; EPO; JPO	OR	ON	2013/01/13 00:19
L9	1	5 and 8	US-PGPUB; USPAT; USOCR; FPRS; EPO; JPO	OR	ON	2013/01/13 00:19
L10	0	6 and 8	US-PGPUB; USPAT; USOCR; FPRS; EPO; JPO	OR	ON	2013/01/13 00:20
L11	2906	(power near2 control\$4 same (increase\$3 rais\$3 adjust\$3 revis\$3 higher more most maximum max maximal larger exceed\$3 greater increment\$3 decreas\$3 lower\$3 reduc\$4 diminish\$3 lessen\$3 mitigat\$3 suppress\$3 attenuat\$3 degrad\$3 decrement\$3) near4 threshold).clm.	US-PGPUB; USPAT; USOCR; FPRS; EPO; JPO	OR	ON	2013/01/13 00:20
L12	2386	(power near2 control\$4 same (increase\$3	US-	OR	ON	2013/01/13

		rais\$3 adjust\$3 revis\$3 higher more most maximum max maximal larger exceed\$3 greater increment\$3 decreas\$3 lower\$3 reduc\$4 diminish\$3 lessen\$3 mitigat\$3 suppress\$3 attenuat\$3 degrad\$3 decrement\$3) near2 threshold).clm.	PGPUB; USPAT; USOCR; FPRS; EPO; JPO			00:21
L13	582	(power near2 control\$4 same (increase\$3 rais\$3 adjust\$3 revis\$3 higher more most maximum max maximal larger exceed\$3 greater increment\$3 decreas\$3 lower\$3 reduc\$4 diminish\$3 lessen\$3 mitigat\$3 suppress\$3 attenuat\$3 degrad\$3 decrement\$3) near2 threshold same (tim\$3 period)).clm.	US- PGPUB; USPAT; USOCR; FPRS; EPO; JPO	OR	ON	2013/01/13 00:22
L14	0	5 and 13	US- PGPUB; USPAT; USOCR; FPRS; EPO; JPO	OR	ON	2013/01/13 00:23
L15	2	6 and 13	US- PGPUB; USPAT; USOCR; FPRS; EPO; JPO	OR	ON	2013/01/13 00:23

1/ 13/ 2013 12:23:55 AM

C:\Users\drego\Documents\EAST\Workspaces\12665427.wsp

Issue Classification 	Application/Control No. 12665427	Applicant(s)/Patent Under Reexamination MICHEL ET AL.
	Examiner DOMINIC E REGO	Art Unit 2647

ORIGINAL						INTERNATIONAL CLASSIFICATION														
CLASS			SUBCLASS			CLAIMED					NON-CLAIMED									
455			522			H	O	4	B	7 / 00 (2006.01.01)										
CROSS REFERENCE(S)																				
CLASS		SUBCLASS (ONE SUBCLASS PER BLOCK)																		
455	68	69																		

<input type="checkbox"/> Claims renumbered in the same order as presented by applicant <input type="checkbox"/> CPA <input type="checkbox"/> T.D. <input type="checkbox"/> R.1.47															
Final	Original	Final	Original	Final	Original	Final	Original	Final	Original	Final	Original	Final	Original	Final	Original
1	1	16	17	32	33										
2	2	17	18	33	34										
3	3	18	19	34	35										
4	4	19	20	35	36										
5	5	20	21		37										
9	6	21	22		38										
10	7	22	23		39										
	8	23	24												
6	9	24	25												
7	10	25	26												
8	11	26	27												
11	12	27	28												
12	13	28	29												
13	14	29	30												
14	15	30	31												
15	16	31	32												

NONE	Total Claims Allowed:	
(Assistant Examiner)	(Date)	35
/DOMINIC E REGO/ Primary Examiner. Art Unit 2647	1/13/2013	O.G. Print Claim(s) O.G. Print Figure
(Primary Examiner)	(Date)	1 1

PART B - FEE(S) TRANSMITTAL

IFU/##

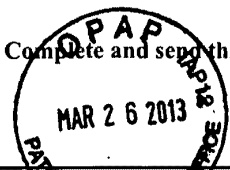

Complete and send this form, together with applicable fee(s), to: **Mail** Mail Stop ISSUE FEE
Commissioner for Patents
P.O. Box 1450
Alexandria, Virginia 22313-1450
or Fax (571)-273-2885

INSTRUCTIONS: This form should be used for transmitting the ISSUE FEE and PUBLICATION FEE (if required). Blocks 1 through 5 should be completed where appropriate. All further correspondence including the Patent, advance orders and notification of maintenance fees will be mailed to the current correspondence address as indicated unless directed below or directed otherwise in Block 1, by (a) specifying a new correspondence address; and/or (b) indicating a separate "FEE ADDRESS" for maintenance fee notifications.

CURRENT CORRESPONDENCE ADDRESS (Note: Use Block 1 for any change of address)

Note: A certificate of mailing can only be used for domestic mailings of the Fee(s) Transmittal. This certificate cannot be used for any other accompanying papers. Each additional paper, such as an assignment or formal drawing, must have its own certificate of mailing or transmission.

29683 7590 01/18/2013
HARRINGTON & SMITH
4 RESEARCH DRIVE, Suite 202
SHELTON, CT 06484-6212

Certificate of Mailing or Transmission
 I hereby certify that this Fee(s) Transmittal is being deposited with the United States Postal Service with sufficient postage for first class mail in an envelope addressed to the Mail Stop ISSUE FEE address above, or being facsimile transmitted to the USPTO (571) 273-2885, on the date indicated below.

<i>Cathy Sumner</i>	(Depositor's name)
<i>Cathy Sumner</i>	(Signature)
3/21/13	(Date)

APPLICATION NO.	FILING DATE	FIRST NAMED INVENTOR	ATTORNEY DOCKET NO.	CONFIRMATION NO.
-----------------	-------------	----------------------	---------------------	------------------

12/665,427 01/22/2010 Juergen Michel 863.0156.U1(US) 1011
 03/27/2013 CNGUYEN3 00000023 501924 12665427

TITLE OF INVENTION: Power Headroom Reporting Method

01 FC:1501 1700.00 DA
 02 FC:1504 300.00 DA

APPLN. TYPE	SMALL ENTITY	ISSUE FEE DUE	PUBLICATION FEE DUE	PREV. PAID ISSUE FEE	TOTAL FEE(S) DUE	DATE DUE
nonprovisional	NO	\$1770	\$300	\$0	\$2070	04/18/2013

EXAMINER	ART UNIT	CLASS-SUBCLASS
REGO, DOMINIC E	2647	455-522000

1. Change of correspondence address or indication of "Fee Address" (37 CFR 1.563).

Change of correspondence address (or Change of Correspondence Address form PTO/SB/122) attached.

"Fee Address" indication (or "Fee Address" Indication form PTO/SB/47; Rev 03-02 or more recent) attached. Use of a Customer Number is required.

2. For printing on the patent front page, list

(1) the names of up to 3 registered patent attorneys or agents OR, alternatively, 1 Harrington & Smith

(2) the name of a single firm (having as a member a registered attorney or agent) and the names of up to 2 registered patent attorneys or agents. If no name is listed, no name will be printed. 2 _____

3 _____

3. ASSIGNEE NAME AND RESIDENCE DATA TO BE PRINTED ON THE PATENT (print or type)

PLEASE NOTE: Unless an assignee is identified below, no assignee data will appear on the patent. If an assignee is identified below, the document has been filed for recordation as set forth in 37 CFR 3.11. Completion of this form is NOT a substitute for filing an assignment.

(A) NAME OF ASSIGNEE **Nokia Siemens Networks Oy**

(B) RESIDENCE: (CITY and STATE OR COUNTRY) **Espoo, Finland**

Please check the appropriate assignee category or categories (will not be printed on the patent): Individual Corporation or other private group entity Government

4a. The following fee(s) are submitted:

Issue Fee

Publication Fee (No small entity discount permitted)

Advance Order - # of Copies _____

4b. Payment of Fee(s): (Please first reapply any previously paid issue fee shown above)

A check is enclosed.

Payment by credit card. Form PTO-2038 is attached.

The Director is hereby authorized to charge the required fee(s), any deficiency, or credit any overpayment, to Deposit Account Number 50-1924 (enclose an extra copy of this form).

5. Change in Entity Status (from status indicated above)

a. Applicant claims SMALL ENTITY status. See 37 CFR 1.27. b. Applicant is no longer claiming SMALL ENTITY status. See 37 CFR 1.27(g)(2).

NOTE: The Issue Fee and Publication Fee (if required) will not be accepted from anyone other than the applicant; a registered attorney or agent; or the assignee or other party in interest as shown by the records of the United States Patent and Trademark Office.

Authorized Signature *John A. Garrity* Date 3/19/2013

Typed or printed name John A. Garrity Registration No. 60,470

This collection of information is required by 37 CFR 1.311. The information is required to obtain or retain a benefit by the public which is to file (and by the USPTO to process) an application. Confidentiality is governed by 35 U.S.C. 122 and 37 CFR 1.14. This collection is estimated to take 12 minutes to complete, including gathering, preparing, and submitting the completed application form to the USPTO. Time will vary depending upon the individual case. Any comments on the amount of time you require to complete this form and/or suggestions for reducing this burden, should be sent to the Chief Information Officer, U.S. Patent and Trademark Office, U.S. Department of Commerce, P.O. Box 1450, Alexandria, Virginia 22313-1450. DO NOT SEND FEES OR COMPLETED FORMS TO THIS ADDRESS. SEND TO: Commissioner for Patents, P.O. Box 1450, Alexandria, Virginia 22313-1450.

Under the Paperwork Reduction Act of 1995, no persons are required to respond to a collection of information unless it displays a valid OMB control number.



UNITED STATES PATENT AND TRADEMARK OFFICE

UNITED STATES DEPARTMENT OF COMMERCE
United States Patent and Trademark Office
Address: COMMISSIONER FOR PATENTS
P.O. Box 1450
Alexandria, Virginia 22313-1450
www.uspto.gov

APPLICATION NO.	FILING DATE	FIRST NAMED INVENTOR	ATTORNEY DOCKET NO.	CONFIRMATION NO.
12/665,427	01/22/2010	Juergen Michel	863.0156.U1(US)	1011
29683	7590	04/16/2013	EXAMINER	
HARRINGTON & SMITH 4 RESEARCH DRIVE, Suite 202 SHELTON, CT 06484-6212			REGO, DOMINIC E	
			ART UNIT	PAPER NUMBER
			2647	
			MAIL DATE	DELIVERY MODE
			04/16/2013	PAPER

Please find below and/or attached an Office communication concerning this application or proceeding.

The time period for reply, if any, is set in the attached communication.



UNITED STATES PATENT AND TRADEMARK OFFICE

Commissioner for Patents
United States Patent and Trademark Office
P.O. Box 1450
Alexandria, VA 22313-1450
www.uspto.gov

Application No. : 12665427
Applicant : Michel
Filing Date : 01/22/2010
Date Mailed : 04/16/2013

NOTICE TO FILE CORRECTED APPLICATION PAPERS

Notice of Allowance Mailed

This application has been accorded an Allowance Date and is being prepared for issuance. The application, however, is incomplete for the reasons below.

Applicant is given 1 month from the mail date of this Notice, or the time remaining from the Notice of Allowance and Fee(s) Due, whichever is longer, within which to respond.

The application is not in compliance with 37 CFR 1.78, as indicated in the attachment. The consequences of failure to respond within the above-identified time period are set forth in the attachment.

Even if the Office has recognized a benefit claim and has entered it into the Office's database and included it on applicant's filing receipt, the benefit claim is not a proper benefit claim unless the reference in compliance with 37 CFR 1.78 is included, depending upon the application's filing date and as indicated in the attachment, in an application data sheet or in the first sentence(s) of the specification and all other requirements are met.

This period for reply is NOT extendable under 37 CFR 1.136(a).

See attachment.

*A copy of this notice **MUST** be returned with the reply. Please address response to "Mail Stop Issue Fee, Commissioner for Patents, P.O. Box 1450, Alexandria, VA 22313-1450".*

Jonathan Robbins
Publication Branch
Office of Data Management
(571) 272-4200

Application No. 12665427

**APPLICATION FILED PRIOR TO SEPTEMBER 16, 2012,
NOT IN COMPLIANCE WITH 37 CFR 1.78**

- The 37 CFR 1.78(a)(2) reference on the application data sheet or in the first sentence(s) of the specification does not indicate the relationship (continuation, division, continuation-in-part) to the prior U.S. nonprovisional application or international application designating the U.S. See document coded _____ dated _____, listing application number(s) _____.
- The 37 CFR 1.78(a)(2) reference on the application data sheet or in the first sentence(s) of the specification following the title does not provide the U.S. nonprovisional application number (series code and serial number) or, with respect to an international PCT application designating the U.S., it provides the international application number or international filing date but not both. See document coded _____ dated _____, in which the following is missing: _____.
- The 37 CFR 1.78(a)(2) reference on the application data sheet or in the first sentence(s) of the specification following the title shows an incorrect, incomplete, or illegible U.S. nonprovisional application number, international PCT application number, or international PCT filing date. See document coded _____ dated _____, in which the following error was made: _____.
- The 37 CFR 1.78(a)(2) reference to the prior U.S. nonprovisional application or international application designating the U.S. is not present on an application data sheet or in the first sentence(s) of the specification following the title, thus removing the validating link under 35 U.S.C. 119(a)-(d) to a prior foreign application or under 35 U.S.C. 119(e) to a prior U.S. provisional application.
- The 37 CFR 1.78(a)(2) reference to the prior U.S. nonprovisional application or international application designating the U.S. is not present on an application data sheet or in the first sentence(s) of the specification following the title.
- The 37 CFR 1.78(a)(5) reference to the prior U.S. provisional application is not present on an application data sheet or in first sentence(s) of the specification following the title.
- The 37 CFR 1.78(a)(5) reference to the prior U.S. provisional application on an application data sheet or in first sentence(s) of the specification following the title does not provide the provisional application number (series code and serial number). See document coded _____ dated _____, in which the following is missing: _____.
- The 37 CFR 1.78(a)(5) reference to the prior U.S. provisional application on an application data sheet or in first sentence(s) of the specification following the title shows an incorrect, incomplete, or illegible U.S. provisional application number. See document coded _____ dated _____, in which the following error was made: _____.
- Other: _____.

HOW TO RESPOND

A proper response to this notice would include any one of: (1) a supplemental Application Data Sheet (ADS) pursuant to 37 CFR 1.76(c) which provides benefit information that complies with 37 CFR 1.78(a)(2) or 37 CFR 1.78(a)(5); (2) an amendment to the first sentence(s) of the specification which provides benefit information that complies with 37 CFR 1.78(a)(2) or 37 CFR 1.78(a)(5); or (3) a petition filed pursuant to the provisions of 37 CFR 1.78(a)(3) or 37 CFR 1.78(a)(6) if the benefit information from the document identified above by code and date does not accurately reflect the benefits under 35 U.S.C. 119(e), 120, 121 or 365(c) as claimed by applicant (a grantable petition would include either a supplemental ADS or an amendment to the first sentence(s) of the specification as required by 37 CFR 1.78(a)(3)(i) or 37 CFR 1.78(a)(6)(i)). Such amendments to the specification or supplemental ADS submission may be filed after payment of the issue fee if limited to informalities noted herein. See Waiver of 37 CFR 1.312 for Document Required by Office of Patent Publication, 1280 Off. Gaz. Patent Office 918 (March 23, 2004).

WARNING: If Applicant fails to timely submit a proper response, the benefit information will be deleted and the patent will be printed without the benefit information present.



Handwritten initials: FN

IN THE UNITED STATES PATENT AND TRADEMARK OFFICE

IN RE U.S. PATENT APPLICATION OF:

APPLICANTS: Michel et al.
 SERIAL NO.: 12/665,427
 FILING DATE: January 22, 2010
 EXAMINER: Dominic E. Rego
 ART UNIT: 2647
 ATT'Y DOCKET NO.: 863.0156.U1(US)
 TITLE: POWER HEADROOM REPORTING METHOD

Mail Stop Issue Fee
 Commissioner for Patents
 P.O. Box 1450
 Alexandria, VA 22313-1450

RESPONSE TO NOTICE TO FILE CORRECTED APPLICATION PAPERS

(Notice of Allowance Mailed)

Sir:

The present amendment is submitted in response to the Notice to File Corrected Application Papers of April 16, 2013 on the above-identified application. It is being submitted prior to the end of the shortened 1-month period for response set in the notice. As such, no request for an extension of time is believed to be necessary. In the event that the undersigned attorney is incorrect on this point, please consider this to be such a request, and charge Deposit Account No. 50-1924 for any fee required under 37 C.F.R. §1.17(a).

Please amend the application as shown below.

S.N.: 12/665,427
Art Unit: 2647

AMENDMENTS TO THE SPECIFICATION:

On page 1 of the specification, immediately above the section heading FIELD OF THE INVENTION, please insert:

CROSS-REFERENCE TO RELATED APPLICATIONS

This application claims the benefit of Provisional Application No. 60/936,649, filed June 20, 2007, the disclosure of which is incorporated herein by reference in its entirety.

S.N.: 12/665,427
Art Unit: 2647

REMARKS

The present amendment is respectfully submitted in response to the Notice to File Corrected Application Papers of April 16, 2013 on the above-identified application. Entry of the amendment is respectfully requested. A copy of the Notice to File Corrected Application Papers accompanies this paper.

Applicant respectfully requests the application now proceed to issuance as the issue fee has been paid and the requirements of the notice have been satisfied. In the event that further action is required, please contact the undersigned.

Respectfully submitted:

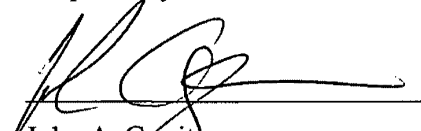

John A. Garrity
Registration No. 60,470
Customer No.: 29683

4/22/2013

Date

HARRINGTON & SMITH, ATTORNEYS AT LAW, LLC
4 Research Drive
Shelton, CT 06484-6212

Telephone: (203) 925-9400 ext. 15
Facsimile: (203) 944-0245
E-mail: jgarrity@hspatent.com

CERTIFICATE OF MAILING

I hereby certify that this correspondence is being deposited with the United States Postal Service as first class mail in an envelope addressed to: Mail Stop Issue Fee, Commissioner for Patents, P.O. Box 1450, Alexandria, VA 22313-1450.

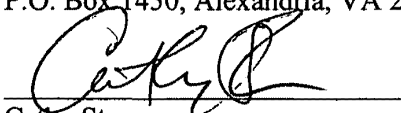

Cathy Sturmer

4/22/13

Date



UNITED STATES PATENT AND TRADEMARK OFFICE

JAC

UNITED STATES DEPARTMENT OF COMMERCE
United States Patent and Trademark Office
Address: COMMISSIONER FOR PATENTS
P.O. Box 1450
Alexandria, Virginia 22313-1450
www.uspto.gov

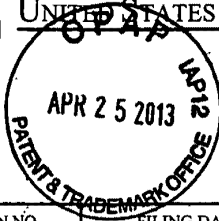

APPLICATION NO.	FILING DATE	FIRST NAMED INVENTOR	ATTORNEY DOCKET NO.	CONFIRMATION NO.
-----------------	-------------	----------------------	---------------------	------------------

12/665,427	01/22/2010	Juergen Michel	863.0156.U1(US)	1011
------------	------------	----------------	-----------------	------

29683 7590 04/16/2013
HARRINGTON & SMITH
4 RESEARCH DRIVE, Suite 202
SHELTON, CT 06484-6212

APR 18 2013

EXAMINER

REGO, DOMINIC E

ART UNIT	PAPER NUMBER
----------	--------------

2647

MAIL DATE	DELIVERY MODE
-----------	---------------

04/16/2013

PAPER

Please find below and/or attached an Office communication concerning this application or proceeding.

The time period for reply, if any, is set in the attached communication.

US ACTION _____
DUE DATE 5-16-13
PAID DATED 4-16-13
OA _____
MSC PF _____
APPEAL _____
OTHER Reference to provisional



UNITED STATES PATENT AND TRADEMARK OFFICE

Commissioner for Patents
United States Patent and Trademark Office
P.O. Box 1450
Alexandria, VA 22313-1450
www.uspto.gov

Application No. : 12665427
Applicant : Michel
Filing Date : 01/22/2010
Date Mailed : 04/16/2013

NOTICE TO FILE CORRECTED APPLICATION PAPERS

Notice of Allowance Mailed

This application has been accorded an Allowance Date and is being prepared for issuance. The application, however, is incomplete for the reasons below.

Applicant is given 1 month from the mail date of this Notice, or the time remaining from the Notice of Allowance and Fee(s) Due, whichever is longer, within which to respond.

The application is not in compliance with 37 CFR 1.78, as indicated in the attachment. The consequences of failure to respond within the above-identified time period are set forth in the attachment.

Even if the Office has recognized a benefit claim and has entered it into the Office's database and included it on applicant's filing receipt, the benefit claim is not a proper benefit claim unless the reference in compliance with 37 CFR 1.78 is included, depending upon the application's filing date and as indicated in the attachment, in an application data sheet or in the first sentence(s) of the specification and all other requirements are met.

This period for reply is NOT extendable under 37 CFR 1.136(a).

See attachment.

*A copy of this notice **MUST** be returned with the reply. Please address response to
"Mail Stop Issue Fee, Commissioner for Patents,
P.O. Box 1450, Alexandria, VA 22313-1450".*

Jonathan Robbins
Publication Branch
Office of Data Management
(571) 272-4200

Application No. 12665427

**APPLICATION FILED PRIOR TO SEPTEMBER 16, 2012,
NOT IN COMPLIANCE WITH 37 CFR 1.78**

- The 37 CFR 1.78(a)(2) reference on the application data sheet or in the first sentence(s) of the specification does not indicate the relationship (continuation, division, continuation-in-part) to the prior U.S. nonprovisional application or international application designating the U.S. See document coded _____ dated _____, listing application number(s) _____.
- The 37 CFR 1.78(a)(2) reference on the application data sheet or in the first sentence(s) of the specification following the title does not provide the U.S. nonprovisional application number (series code and serial number) or, with respect to an international PCT application designating the U.S., it provides the international application number or international filing date but not both. See document coded _____ dated _____, in which the following is missing: _____.
- The 37 CFR 1.78(a)(2) reference on the application data sheet or in the first sentence(s) of the specification following the title shows an incorrect, incomplete, or illegible U.S. nonprovisional application number, international PCT application number, or international PCT filing date. See document coded _____ dated _____, in which the following error was made: _____.
- The 37 CFR 1.78(a)(2) reference to the prior U.S. nonprovisional application or international application designating the U.S. is not present on an application data sheet or in the first sentence(s) of the specification following the title, thus removing the validating link under 35 U.S.C. 119(a)-(d) to a prior foreign application or under 35 U.S.C. 119(e) to a prior U.S. provisional application.
- The 37 CFR 1.78(a)(2) reference to the prior U.S. nonprovisional application or international application designating the U.S. is not present on an application data sheet or in the first sentence(s) of the specification following the title.
- The 37 CFR 1.78(a)(5) reference to the prior U.S. provisional application is not present on an application data sheet or in first sentence(s) of the specification following the title.
- The 37 CFR 1.78(a)(5) reference to the prior U.S. provisional application on an application data sheet or in first sentence(s) of the specification following the title does not provide the provisional application number (series code and serial number). See document coded _____ dated _____, in which the following is missing: _____.
- The 37 CFR 1.78(a)(5) reference to the prior U.S. provisional application on an application data sheet or in first sentence(s) of the specification following the title shows an incorrect, incomplete, or illegible U.S. provisional application number. See document coded _____ dated _____, in which the following error was made: _____.
- Other: _____.

HOW TO RESPOND

A proper response to this notice would include any one of: (1) a supplemental Application Data Sheet (ADS) pursuant to 37 CFR 1.76(c) which provides benefit information that complies with 37 CFR 1.78(a)(2) or 37 CFR 1.78(a)(5); (2) an amendment to the first sentence(s) of the specification which provides benefit information that complies with 37 CFR 1.78(a)(2) or 37 CFR 1.78(a)(5); or (3) a petition filed pursuant to the provisions of 37 CFR 1.78(a)(3) or 37 CFR 1.78(a)(6) if the benefit information from the document identified above by code and date does not accurately reflect the benefits under 35 U.S.C. 119(e), 120, 121 or 365(c) as claimed by applicant (a grantable petition would include either a supplemental ADS or an amendment to the first sentence(s) of the specification as required by 37 CFR 1.78(a)(3)(i) or 37 CFR 1.78(a)(6)(i)). Such amendments to the specification or supplemental ADS submission may be filed after payment of the issue fee if limited to informalities noted herein. See Waiver of 37 CFR 1.312 for Document Required by Office of Patent Publication, 1280 Off. Gaz. Patent Office 918 (March 23, 2004).

WARNING: If Applicant fails to timely submit a proper response, the benefit information will be deleted and the patent will be printed without the benefit information present.



UNITED STATES PATENT AND TRADEMARK OFFICE

UNITED STATES DEPARTMENT OF COMMERCE
United States Patent and Trademark Office
Address: COMMISSIONER FOR PATENTS
P.O. Box 1450
Alexandria, Virginia 22313-1450
www.uspto.gov

APPLICATION NO.	FILING DATE	FIRST NAMED INVENTOR	ATTORNEY DOCKET NO.	CONFIRMATION NO.
12/665,427	01/22/2010	Juergen Michel	863.0156.U1(US)	1011

29683 7590 05/07/2013
HARRINGTON & SMITH
4 RESEARCH DRIVE, Suite 202
SHELTON, CT 06484-6212

EXAMINER

REGO, DOMINIC E

ART UNIT	PAPER NUMBER
----------	--------------

2647

MAIL DATE	DELIVERY MODE
-----------	---------------

05/07/2013

PAPER

Please find below and/or attached an Office communication concerning this application or proceeding.

The time period for reply, if any, is set in the attached communication.

Response to Rule 312 Communication	Application No.	Applicant(s)
	12/665,427	MICHEL ET AL.
	Examiner	Art Unit

-- The MAILING DATE of this communication appears on the cover sheet with the correspondence address --

1. The amendment filed on 25 April 2013 under 37 CFR 1.312 has been considered, and has been:
- a) entered.
 - b) entered as directed to matters of form not affecting the scope of the invention.
 - c) disapproved because the amendment was filed after the payment of the issue fee.
Any amendment filed after the date the issue fee is paid must be accompanied by a petition under 37 CFR 1.313(c)(1) and the required fee to withdraw the application from issue.
 - d) disapproved. See explanation below.
 - e) entered in part. See explanation below.

Publishing Division



UNITED STATES PATENT AND TRADEMARK OFFICE

UNITED STATES DEPARTMENT OF COMMERCE
United States Patent and Trademark Office
Address: COMMISSIONER FOR PATENTS
P. O. Box 1450
Alexandria, Virginia 22313-1450
www.uspto.gov

APPLICATION NO.	ISSUE DATE	PATENT NO.	ATTORNEY DOCKET NO.	CONFIRMATION NO.
-----------------	------------	------------	---------------------	------------------

12/665,427	06/04/2013	8457676	863.0156.U1(US)	1011
------------	------------	---------	-----------------	------

29683 7590 05/15/2013
HARRINGTON & SMITH
4 RESEARCH DRIVE, Suite 202
SHELTON, CT 06484-6212

ISSUE NOTIFICATION

The projected patent number and issue date are specified above.

Determination of Patent Term Adjustment under 35 U.S.C. 154 (b)
(application filed on or after May 29, 2000)

The Patent Term Adjustment is 396 day(s). Any patent to issue from the above-identified application will include an indication of the adjustment on the front page.

If a Continued Prosecution Application (CPA) was filed in the above-identified application, the filing date that determines Patent Term Adjustment is the filing date of the most recent CPA.

Applicant will be able to obtain more detailed information by accessing the Patent Application Information Retrieval (PAIR) WEB site (<http://pair.uspto.gov>).

Any questions regarding the Patent Term Extension or Adjustment determination should be directed to the Office of Patent Legal Administration at (571)-272-7702. Questions relating to issue and publication fee payments should be directed to the Application Assistance Unit (AAU) of the Office of Data Management (ODM) at (571)-272-4200.

APPLICANT(s) (Please see PAIR WEB site <http://pair.uspto.gov> for additional applicants):

Juergen Michel, Munchen, GERMANY;
Klaus Ingemann Pedersen, Aalborg, DENMARK;
Claudio Rosa, Randers, DENMARK;

The United States represents the largest, most dynamic marketplace in the world and is an unparalleled location for business investment, innovation, and commercialization of new technologies. The USA offers tremendous resources and advantages for those who invest and manufacture goods here. Through SelectUSA, our nation works to encourage and facilitate business investment. To learn more about why the USA is the best country in the world to develop technology, manufacture products, and grow your business, visit SelectUSA.gov.

IN THE UNITED STATES PATENT AND TRADEMARK OFFICE

First Named Inventor: Juergen Michel
Patent No.: 8,457,676
Issued: June 4, 2013
Serial No.: 12/665,427
Filed: January 22, 2010
For: POWER HEADROOM REPORTING
METHOD

Group Art Unit: 2647
Examiner: REGO, DOMINIC E
Confirmation No.: 1011

REQUEST FOR CERTIFICATE OF CORRECTION UNDER §1.323
USPTO MISTAKE

Mail Stop Certificate of Corrections Branch
Commissioner for Patents
P. O. Box 1450
Alexandria, VA 22313-1450

Dear Sir:

Submitted herewith is a Certificate of Correction (Form PTO/SB/44) to correct typographical or clerical errors in U.S. Patent No. 8,457,676 which occur in claim 33 (columns 9 and 10).

The mistake was incurred through the fault of the Office and is clearly disclosed in the records of the Office. During an examiner-initiated interview on January 9, 2013 it was agreed to add claim 8 to each of the independent claims by examiner's amendment. The examiner inserted the limitations of claim 8 into claim 34 (claim 33 of issued U.S. Patent No. 8,457,676) in a location within the claim that created a lack of antecedent basis for "the signal." Specifically, "the signal" appears prior to the introduction of "a threshold adjustment signal" within the claim.

This mistake is correctable by moving the limitations added from claim 8 to the end of the claim.
The following markup of claim 33 of U.S. Patent No. 8,457,676 illustrates this correction:

33. A network element comprising:
at least one processor; and
at least one memory including software, where the at least one memory and the software are configured, with the at least one processor, to cause the network element to at least:
- receive a power control headroom report on an uplink from user equipment, in response to the user equipment determining that a set of at least one triggering criterion is met because at least one threshold has been reached, ~~wherein the set of at least one triggering criterion comprises a criterion being met based on reaching a threshold of the at least one threshold of k transmission time intervals following a previous power control headroom report, wherein k is an integer and wherein said at least one threshold adjustable via the signal comprises adjusting the threshold integer k;~~ and
 - provide a threshold adjustment signal to the user equipment in order to adjust the at least one threshold;
wherein the set of at least one triggering criterion comprises a criterion being met based on reaching a threshold of the at least one threshold of k transmission time intervals following a previous power control headroom report, wherein k is an integer and wherein said at least one threshold adjustable via the signal comprises adjusting the threshold integer k.

The following correction is requested:

1. Strike the phrase ", wherein the set of at least one triggering criterion comprises a criterion being met based on reaching a threshold of the at least one threshold of k transmission time intervals following a previous power control headroom report, wherein k is an integer and wherein said at least one threshold adjustable via the signal comprises adjusting the threshold integer k" from lines 10-17 of claim 33 (column 9, line 20 to column 10, line 7), and insert the phrase “; wherein the set of at

least one triggering criterion comprises a criterion being met based on reaching a threshold of the at least one threshold of k transmission time intervals following a previous power control headroom report, wherein k is an integer and wherein said at least one threshold adjustable via the signal comprises adjusting the threshold integer k” after the phrase "provide a threshold adjustment signal to the user equipment in order to adjust the at least one threshold" at line 19 of claim 33 (column 10, line 9).

It is respectfully requested that the attached Certificate of Correction indicating the corrections be issued.

The proposed corrections do not constitute new matter and do not require reexamination.

The Commission is hereby authorized to charge any fees and/or credit any overpayment/refunds to Deposit Account No. **50-2075**.

Respectfully submitted,

PROCOPIO, CORY, HARGREAVES &
SAVITCH

Dated: March 3, 2015

By: /Jacob P. Beers/
Jacob P. Beers
Registration No. 68,574

Procopio, Cory, Hargreaves & Savitch LLP
525 B Street, Suite 2200
San Diego, California 92101-4469
(619) 238-1900
Customer No. 27189

UNITED STATES PATENT AND TRADEMARK OFFICE CERTIFICATE OF CORRECTION

Page 1 of 1

PATENT NO. : 8,457,676

APPLICATION NO.: 12/665,427

ISSUE DATE : June 4, 2013

INVENTOR(S) : Juergen Michel; Klaus Ingemann Pedersen; Caudio Rosa

It is certified that an error appears or errors appear in the above-identified patent and that said Letters Patent is hereby corrected as shown below:

Strike the phrase ", wherein the set of at least one triggering criterion comprises a criterion being met based on reaching a threshold of the at least one threshold of k transmission time intervals following a previous power control headroom report, wherein k is an integer and wherein said at least one threshold adjustable via the signal comprises adjusting the threshold integer k" from lines 10-17 of claim 33, and insert the phrase --; wherein the set of at least one triggering criterion comprises a criterion being met based on reaching a threshold of the at least one threshold of k transmission time intervals following a previous power control headroom report, wherein k is an integer and wherein said at least one threshold adjustable via the signal comprises adjusting the threshold integer k-- after the phrase "provide a threshold adjustment signal to the user equipment in order to adjust the at least one threshold" at line 19 of claim 33.

MAILING ADDRESS OF SENDER (Please do not use customer number below):

Procopio, Cory, Hargreaves & Savitch LLP
525 B Street, Suite 2200
San Diego, CA 92101

This collection of information is required by 37 CFR 1.322, 1.323, and 1.324. The information is required to obtain or retain a benefit by the public which is to file (and by the USPTO to process) an application. Confidentiality is governed by 35 U.S.C. 122 and 37 CFR 1.14. This collection is estimated to take 1.0 hour to complete, including gathering, preparing, and submitting the completed application form to the USPTO. Time will vary depending upon the individual case. Any comments on the amount of time you require to complete this form and/or suggestions for reducing this burden, should be sent to the Chief Information Officer, U.S. Patent and Trademark Office, U.S. Department of Commerce, P.O. Box 1450, Alexandria, VA 22313-1450. **DO NOT SEND FEES OR COMPLETED FORMS TO THIS ADDRESS. SEND TO: Attention Certificate of Corrections Branch, Commissioner for Patents, P.O. Box 1450, Alexandria, VA 22313-1450.**

If you need assistance in completing the form, call 1-800-PTO-9199 and select option 2.

Privacy Act Statement

The **Privacy Act of 1974 (P.L. 93-579)** requires that you be given certain information in connection with your submission of the attached form related to a patent application or patent. Accordingly, pursuant to the requirements of the Act, please be advised that: (1) the general authority for the collection of this information is 35 U.S.C. 2(b)(2); (2) furnishing of the information solicited is voluntary; and (3) the principal purpose for which the information is used by the U.S. Patent and Trademark Office is to process and/or examine your submission related to a patent application or patent. If you do not furnish the requested information, the U.S. Patent and Trademark Office may not be able to process and/or examine your submission, which may result in termination of proceedings or abandonment of the application or expiration of the patent.

The information provided by you in this form will be subject to the following routine uses:

1. The information on this form will be treated confidentially to the extent allowed under the Freedom of Information Act (5 U.S.C. 552) and the Privacy Act (5 U.S.C. 552a). Records from this system of records may be disclosed to the Department of Justice to determine whether disclosure of these records is required by the Freedom of Information Act.
2. A record from this system of records may be disclosed, as a routine use, in the course of presenting evidence to a court, magistrate, or administrative tribunal, including disclosures to opposing counsel in the course of settlement negotiations.
3. A record in this system of records may be disclosed, as a routine use, to a Member of Congress submitting a request involving an individual, to whom the record pertains, when the individual has requested assistance from the Member with respect to the subject matter of the record.
4. A record in this system of records may be disclosed, as a routine use, to a contractor of the Agency having need for the information in order to perform a contract. Recipients of information shall be required to comply with the requirements of the Privacy Act of 1974, as amended, pursuant to 5 U.S.C. 552a(m).
5. A record related to an International Application filed under the Patent Cooperation Treaty in this system of records may be disclosed, as a routine use, to the International Bureau of the World Intellectual Property Organization, pursuant to the Patent Cooperation Treaty.
6. A record in this system of records may be disclosed, as a routine use, to another federal agency for purposes of National Security review (35 U.S.C. 181) and for review pursuant to the Atomic Energy Act (42 U.S.C. 218(c)).
7. A record from this system of records may be disclosed, as a routine use, to the Administrator, General Services, or his/her designee, during an inspection of records conducted by GSA as part of that agency's responsibility to recommend improvements in records management practices and programs, under authority of 44 U.S.C. 2904 and 2906. Such disclosure shall be made in accordance with the GSA regulations governing inspection of records for this purpose, and any other relevant (*i.e.*, GSA or Commerce) directive. Such disclosure shall not be used to make determinations about individuals.
8. A record from this system of records may be disclosed, as a routine use, to the public after either publication of the application pursuant to 35 U.S.C. 122(b) or issuance of a patent pursuant to 35 U.S.C. 151. Further, a record may be disclosed, subject to the limitations of 37 CFR 1.14, as a routine use, to the public if the record was filed in an application which became abandoned or in which the proceedings were terminated and which application is referenced by either a published application, an application open to public inspection or an issued patent.
9. A record from this system of records may be disclosed, as a routine use, to a Federal, State, or local law enforcement agency, if the USPTO becomes aware of a violation or potential violation of law or regulation.

Electronic Acknowledgement Receipt

EFS ID:	21659375
Application Number:	12665427
International Application Number:	
Confirmation Number:	1011
Title of Invention:	Power Headroom Reporting Method
First Named Inventor/Applicant Name:	Juergen Michel
Customer Number:	29683
Filer:	Jacob Paul Beers/Wayne Mahoney
Filer Authorized By:	Jacob Paul Beers
Attorney Docket Number:	863.0156.U1(US)
Receipt Date:	03-MAR-2015
Filing Date:	22-JAN-2010
Time Stamp:	18:49:22
Application Type:	U.S. National Stage under 35 USC 371

Payment information:

Submitted with Payment	no
------------------------	----

File Listing:

Document Number	Document Description	File Name	File Size(Bytes)/ Message Digest	Multi Part /.zip	Pages (if appl.)
1	Request for Certificate of Correction	REQUEST_CERTIFICATE_CORRECTION_122611_043US1.pdf	26389 8c1201a31fd71ad2f2e2816de7eff303d867d458	no	3

Warnings:

Information:

2	Request for Certificate of Correction	CERTIFICATE_CORRECTION_12 2611_043US1.pdf	165470 870c1de63d4f6e8c151b4f0ff4ed113f3057c 903	no	2
---	---------------------------------------	----------------------------------------------	------------------------------------------------------------	----	---

Warnings:

Information:

Total Files Size (in bytes):	191859
-------------------------------------	--------

This Acknowledgement Receipt evidences receipt on the noted date by the USPTO of the indicated documents, characterized by the applicant, and including page counts, where applicable. It serves as evidence of receipt similar to a Post Card, as described in MPEP 503.

New Applications Under 35 U.S.C. 111

If a new application is being filed and the application includes the necessary components for a filing date (see 37 CFR 1.53(b)-(d) and MPEP 506), a Filing Receipt (37 CFR 1.54) will be issued in due course and the date shown on this Acknowledgement Receipt will establish the filing date of the application.

National Stage of an International Application under 35 U.S.C. 371

If a timely submission to enter the national stage of an international application is compliant with the conditions of 35 U.S.C. 371 and other applicable requirements a Form PCT/DO/EO/903 indicating acceptance of the application as a national stage submission under 35 U.S.C. 371 will be issued in addition to the Filing Receipt, in due course.

New International Application Filed with the USPTO as a Receiving Office

If a new international application is being filed and the international application includes the necessary components for an international filing date (see PCT Article 11 and MPEP 1810), a Notification of the International Application Number and of the International Filing Date (Form PCT/RO/105) will be issued in due course, subject to prescriptions concerning national security, and the date shown on this Acknowledgement Receipt will establish the international filing date of the application.

Under the Paperwork Reduction Act of 1995, no persons are required to respond to a collection of information unless it displays a valid OMB control number.

POWER OF ATTORNEY TO PROSECUTE APPLICATIONS BEFORE THE USPTO

I hereby revoke all previous powers of attorney given in the application identified in the attached statement under 37 CFR 3.73(b).

I hereby appoint:

Practitioners associated with the Customer Number: 27189

OR

Practitioner(s) named below (if more than ten patent practitioners are to be named, then a customer number must be used):

Name	Registration Number	Name	Registration Number

as attorney(s) or agent(s) to represent the undersigned before the United States Patent and Trademark Office (USPTO) in connection with any and all patent applications assigned only to the undersigned according to the USPTO assignment records or assignment documents attached to this form in accordance with 37 CFR 3.73(b).

Please change the correspondence address for the application identified in the attached statement under 37 CFR 3.73(b) to:

The address associated with Customer Number: 27189

OR

<input type="checkbox"/> Firm or Individual Name			
Address			
City	State	Zip	
Country			
Telephone	Email		

Assignee Name and Address:

Cellular Communications Equipment LLC
 2400 Dallas Parkway, Suite 200
 Plano, TX 75093

A copy of this form, together with a statement under 37 CFR 3.73(b) (Form PTO/SB/96 or equivalent) is required to be filed in each application in which this form is used. The statement under 37 CFR 3.73(b) may be completed by one of the practitioners appointed in this form if the appointed practitioner is authorized to act on behalf of the assignee, and must identify the application in which this Power of Attorney is to be filed.

SIGNATURE of Assignee of Record

The individual whose signature and title is supplied below is authorized to act on behalf of the assignee

Signature		Date	April 1, 2015
Name	Marvin Key	Telephone	214-291-4647
Title	Director and Chief Executive Officer		

This collection of information is required by 37 CFR 1.31, 1.32 and 1.33. The information is required to obtain or retain a benefit by the public which is to file (and by the USPTO to process) an application. Confidentiality is governed by 35 U.S.C. 122 and 37 CFR 1.11 and 1.14. This collection is estimated to take 3 minutes to complete, including gathering, preparing, and submitting the completed application form to the USPTO. Time will vary depending upon the individual case. Any comments on the amount of time you require to complete this form and/or suggestions for reducing this burden, should be sent to the Chief Information Officer, U.S. Patent and Trademark Office, U.S. Department of Commerce, P.O. Box 1450, Alexandria, VA 22313-1450. DO NOT SEND FEES OR COMPLETED FORMS TO THIS ADDRESS. **SEND TO: Commissioner for Patents, P.O. Box 1450, Alexandria, VA 22313-1450.**

If you need assistance in completing the form, call 1-800-PTO-9199 and select option 2.

Privacy Act Statement

The **Privacy Act of 1974 (P.L. 93-579)** requires that you be given certain information in connection with your submission of the attached form related to a patent application or patent. Accordingly, pursuant to the requirements of the Act, please be advised that: (1) the general authority for the collection of this information is 35 U.S.C. 2(b)(2); (2) furnishing of the information solicited is voluntary; and (3) the principal purpose for which the information is used by the U.S. Patent and Trademark Office is to process and/or examine your submission related to a patent application or patent. If you do not furnish the requested information, the U.S. Patent and Trademark Office may not be able to process and/or examine your submission, which may result in termination of proceedings or abandonment of the application or expiration of the patent.

The information provided by you in this form will be subject to the following routine uses:

1. The information on this form will be treated confidentially to the extent allowed under the Freedom of Information Act (5 U.S.C. 552) and the Privacy Act (5 U.S.C. 552a). Records from this system of records may be disclosed to the Department of Justice to determine whether disclosure of these records is required by the Freedom of Information Act.
2. A record from this system of records may be disclosed, as a routine use, in the course of presenting evidence to a court, magistrate, or administrative tribunal, including disclosures to opposing counsel in the course of settlement negotiations.
3. A record in this system of records may be disclosed, as a routine use, to a Member of Congress submitting a request involving an individual, to whom the record pertains, when the individual has requested assistance from the Member with respect to the subject matter of the record.
4. A record in this system of records may be disclosed, as a routine use, to a contractor of the Agency having need for the information in order to perform a contract. Recipients of information shall be required to comply with the requirements of the Privacy Act of 1974, as amended, pursuant to 5 U.S.C. 552a(m).
5. A record related to an International Application filed under the Patent Cooperation Treaty in this system of records may be disclosed, as a routine use, to the International Bureau of the World Intellectual Property Organization, pursuant to the Patent Cooperation Treaty.
6. A record in this system of records may be disclosed, as a routine use, to another federal agency for purposes of National Security review (35 U.S.C. 181) and for review pursuant to the Atomic Energy Act (42 U.S.C. 218(c)).
7. A record from this system of records may be disclosed, as a routine use, to the Administrator, General Services, or his/her designee, during an inspection of records conducted by GSA as part of that agency's responsibility to recommend improvements in records management practices and programs, under authority of 44 U.S.C. 2904 and 2906. Such disclosure shall be made in accordance with the GSA regulations governing inspection of records for this purpose, and any other relevant (*i.e.*, GSA or Commerce) directive. Such disclosure shall not be used to make determinations about individuals.
8. A record from this system of records may be disclosed, as a routine use, to the public after either publication of the application pursuant to 35 U.S.C. 122(b) or issuance of a patent pursuant to 35 U.S.C. 151. Further, a record may be disclosed, subject to the limitations of 37 CFR 1.14, as a routine use, to the public if the record was filed in an application which became abandoned or in which the proceedings were terminated and which application is referenced by either a published application, an application open to public inspection or an issued patent.
9. A record from this system of records may be disclosed, as a routine use, to a Federal, State, or local law enforcement agency, if the USPTO becomes aware of a violation or potential violation of law or regulation.

Electronic Acknowledgement Receipt

EFS ID:	21960702
Application Number:	12665427
International Application Number:	
Confirmation Number:	1011
Title of Invention:	Power Headroom Reporting Method
First Named Inventor/Applicant Name:	Juergen Michel
Customer Number:	29683
Filer:	Richard Ernest Campbell/Wayne Mahoney
Filer Authorized By:	Richard Ernest Campbell
Attorney Docket Number:	863.0156.U1(US)
Receipt Date:	03-APR-2015
Filing Date:	22-JAN-2010
Time Stamp:	15:04:40
Application Type:	U.S. National Stage under 35 USC 371

Payment information:

Submitted with Payment	no
------------------------	----

File Listing:

Document Number	Document Description	File Name	File Size(Bytes)/ Message Digest	Multi Part /.zip	Pages (if appl.)
1	Assignee showing of ownership per 37 CFR 3.73	373STMT_122611_043US1.pdf	430167 2d0dd95faca95226e10165c44f54bc5cc4604803	no	2

Warnings:

Information:

2	Assignee showing of ownership per 37 CFR 3.73	373_SUPPL_122611_043US1.pdf	13387 6ff680d2b27ed365fd77b28199eff0f986583638	no	1
Warnings:					
Information:					
3	Assignee showing of ownership per 37 CFR 3.73	ASSIGNCOPY_2_122611.pdf	1056335 307b904db875170d1cb1f0f841744ba9eff9a79d	no	7
Warnings:					
Information:					
4	Power of Attorney	SB_80_POA_122611.PDF	271404 9284c9e739312825b9209c57e83a40019adb0e95	no	2
Warnings:					
Information:					
Total Files Size (in bytes):				1771293	
<p>This Acknowledgement Receipt evidences receipt on the noted date by the USPTO of the indicated documents, characterized by the applicant, and including page counts, where applicable. It serves as evidence of receipt similar to a Post Card, as described in MPEP 503.</p> <p><u>New Applications Under 35 U.S.C. 111</u> If a new application is being filed and the application includes the necessary components for a filing date (see 37 CFR 1.53(b)-(d) and MPEP 506), a Filing Receipt (37 CFR 1.54) will be issued in due course and the date shown on this Acknowledgement Receipt will establish the filing date of the application.</p> <p><u>National Stage of an International Application under 35 U.S.C. 371</u> If a timely submission to enter the national stage of an international application is compliant with the conditions of 35 U.S.C. 371 and other applicable requirements a Form PCT/DO/EO/903 indicating acceptance of the application as a national stage submission under 35 U.S.C. 371 will be issued in addition to the Filing Receipt, in due course.</p> <p><u>New International Application Filed with the USPTO as a Receiving Office</u> If a new international application is being filed and the international application includes the necessary components for an international filing date (see PCT Article 11 and MPEP 1810), a Notification of the International Application Number and of the International Filing Date (Form PCT/RO/105) will be issued in due course, subject to prescriptions concerning national security, and the date shown on this Acknowledgement Receipt will establish the international filing date of the application.</p>					

STATEMENT UNDER 37 CFR 3.73(b)

Applicant/Patent Owner: CELLULAR COMMUNICATIONS EQUIPMENT LLC

Application No./Patent No.: 8,457,676 Filed/Issue Date: June 4, 2013

Titled: POWER HEADROOM REPORTING METHOD

CELLULAR COMMUNICATIONS EQUIPMENT LI, a Limited Liability Company

(Name of Assignee) (Type of Assignee, e.g., corporation, partnership, university, government agency, etc.)

states that it is:

1. the assignee of the entire right, title, and interest in;
2. an assignee of less than the entire right, title, and interest in
 (The extent (by percentage) of its ownership interest is _____ %); or
3. the assignee of an undivided interest in the entirety of (a complete assignment from one of the joint inventors was made)

the patent application/patent identified above, by virtue of either:

A. An assignment from the inventor(s) of the patent application/patent identified above. The assignment was recorded in the United States Patent and Trademark Office at Reel _____, Frame _____, or for which a copy therefore is attached.

OR

B. A chain of title from the inventor(s), of the patent application/patent identified above, to the current assignee as follows:

1. From: PEDERSEN, KLAUS INGEMANN; ROSA, CLA To: NOKIA SIEMENS NETWORKS OY

The document was recorded in the United States Patent and Trademark Office at
 Reel 023841, Frame 0786, or for which a copy thereof is attached.

2. From: MICHEL, JUERGEN To: NOKIA SIEMENS NETWORKS OY

The document was recorded in the United States Patent and Trademark Office at
 Reel 023844, Frame 0041, or for which a copy thereof is attached.

3. From: NOKIA SIEMENS NETWORKS OY To: NOKIA SOLUTIONS AND NETWORKS OY

The document was recorded in the United States Patent and Trademark Office at
 Reel 034294, Frame 0603, or for which a copy thereof is attached.

Additional documents in the chain of title are listed on a supplemental sheet(s).

As required by 37 CFR 3.73(b)(1)(i), the documentary evidence of the chain of title from the original owner to the assignee was, or concurrently is being, submitted for recordation pursuant to 37 CFR 3.11.

[NOTE: A separate copy (i.e., a true copy of the original assignment document(s)) must be submitted to Assignment Division in accordance with 37 CFR Part 3, to record the assignment in the records of the USPTO. See MPEP 302.08]

The undersigned (whose title is supplied below) is authorized to act on behalf of the assignee.

/Richard E. Campbell/
 Signature

April 2, 2015
 Date

Richard E. Campbell
 Printed or Typed Name

Attorney of Record
 Title

This collection of information is required by 37 CFR 3.73(b). The information is required to obtain or retain a benefit by the public which is to file (and by the USPTO to process) an application. Confidentiality is governed by 35 U.S.C. 122 and 37 CFR 1.11 and 1.14. This collection is estimated to take 12 minutes to complete, including gathering, preparing, and submitting the completed application form to the USPTO. Time will vary depending upon the individual case. Any comments on the amount of time you require to complete this form and/or suggestions for reducing this burden, should be sent to the Chief Information Officer, U.S. Patent and Trademark Office, U.S. Department of Commerce, P.O. Box 1450, Alexandria, VA 22313-1450. DO NOT SEND FEES OR COMPLETED FORMS TO THIS ADDRESS. **SEND TO: Commissioner for Patents, P.O. Box 1450, Alexandria, VA 22313-1450.**

Privacy Act Statement

The **Privacy Act of 1974 (P.L. 93-579)** requires that you be given certain information in connection with your submission of the attached form related to a patent application or patent. Accordingly, pursuant to the requirements of the Act, please be advised that: (1) the general authority for the collection of this information is 35 U.S.C. 2(b)(2); (2) furnishing of the information solicited is voluntary; and (3) the principal purpose for which the information is used by the U.S. Patent and Trademark Office is to process and/or examine your submission related to a patent application or patent. If you do not furnish the requested information, the U.S. Patent and Trademark Office may not be able to process and/or examine your submission, which may result in termination of proceedings or abandonment of the application or expiration of the patent.

The information provided by you in this form will be subject to the following routine uses:

1. The information on this form will be treated confidentially to the extent allowed under the Freedom of Information Act (5 U.S.C. 552) and the Privacy Act (5 U.S.C. 552a). Records from this system of records may be disclosed to the Department of Justice to determine whether disclosure of these records is required by the Freedom of Information Act.
2. A record from this system of records may be disclosed, as a routine use, in the course of presenting evidence to a court, magistrate, or administrative tribunal, including disclosures to opposing counsel in the course of settlement negotiations.
3. A record in this system of records may be disclosed, as a routine use, to a Member of Congress submitting a request involving an individual, to whom the record pertains, when the individual has requested assistance from the Member with respect to the subject matter of the record.
4. A record in this system of records may be disclosed, as a routine use, to a contractor of the Agency having need for the information in order to perform a contract. Recipients of information shall be required to comply with the requirements of the Privacy Act of 1974, as amended, pursuant to 5 U.S.C. 552a(m).
5. A record related to an International Application filed under the Patent Cooperation Treaty in this system of records may be disclosed, as a routine use, to the International Bureau of the World Intellectual Property Organization, pursuant to the Patent Cooperation Treaty.
6. A record in this system of records may be disclosed, as a routine use, to another federal agency for purposes of National Security review (35 U.S.C. 181) and for review pursuant to the Atomic Energy Act (42 U.S.C. 218(c)).
7. A record from this system of records may be disclosed, as a routine use, to the Administrator, General Services, or his/her designee, during an inspection of records conducted by GSA as part of that agency's responsibility to recommend improvements in records management practices and programs, under authority of 44 U.S.C. 2904 and 2906. Such disclosure shall be made in accordance with the GSA regulations governing inspection of records for this purpose, and any other relevant (*i.e.*, GSA or Commerce) directive. Such disclosure shall not be used to make determinations about individuals.
8. A record from this system of records may be disclosed, as a routine use, to the public after either publication of the application pursuant to 35 U.S.C. 122(b) or issuance of a patent pursuant to 35 U.S.C. 151. Further, a record may be disclosed, subject to the limitations of 37 CFR 1.14, as a routine use, to the public if the record was filed in an application which became abandoned or in which the proceedings were terminated and which application is referenced by either a published application, an application open to public inspection or an issued patent.
9. A record from this system of records may be disclosed, as a routine use, to a Federal, State, or local law enforcement agency, if the USPTO becomes aware of a violation or potential violation of law or regulation.

**STATEMENT UNDER 37 CFR 3.73(b)
CONTINUED**

Applicant/Patent Owner: CELLULAR COMMUNICATIONS EQUIPMENT LLC

Application No./Patent No.: 8,457,676 Filed/Issue Date: June 4, 2013

Titled: POWER HEADROOM REPORTING METHOD

CELLULAR COMMUNICATIONS EQUIPMENT LLC _____, a Limited Liability Company _____
(Name of Assignee) (Type of Assignee, e.g., corporation, partnership, university, government agency, etc.)

B.

4. From: NOKIA SOLUTIONS AND NETWORKS OY

To: CELLULAR COMMUNICATIONS EQUIPMENT LLC

The document was recorded in the United States Patent and Trademark Office at

Reel __, Frame _____, or for which a copy thereof is attached.

ASSIGNMENT

WHEREAS, NOKIA SOLUTIONS AND NETWORKS OY, formally known as NOKIA SIEMENS NETWORKS OY, a Finnish limited liability company, having a principal place of business at Karaportti 3, 02610 Espoo, Finland (hereafter, together with any successors, legal representatives or assigns thereof, called "Assignor") and its affiliates are the beneficial owners of the **Patents and applications listed in Schedule 1 attached hereto;**

AND WHEREAS, CELLULAR COMMUNICATIONS EQUIPMENT LLC, a Texas limited liability company having a place of business at 2400 Dallas Parkway, Suite 200, Plano, Texas 75093 (hereafter, together with any successors, legal representatives or assigns thereof, called "ASSIGNEE") wants to acquire the entire right, title and interest in and to said **Patents and applications listed in Schedule 1 attached hereto**, and all the inventions therein, and Assignor is willing to enter into such assignment.

NOW, THEREFORE, effective on December 24, 2014 and in consideration of the sum of One Dollar (\$1.00) in hand paid and other good and valuable consideration the receipt of which from ASSIGNEE is hereby acknowledged, Assignor has sold, assigned, transferred and set over, and does hereby sell, assign, transfer and set over to ASSIGNEE the entire right, title and interest in and to (a) the **Patents and applications listed in Schedule 1 attached hereto**; (b) all reissues, reexaminations, continuations, continuations-in-part, divisionals, renewals and extensions (collectively "Related Cases") of such patents and patent applications; (c) all patents and patent applications (i) to which any or all of the foregoing directly or indirectly claims priority to, or the benefit of, the filing date, or (ii) for which any or all of the foregoing directly or indirectly forms a basis for priority or otherwise provides the benefit of an earlier filing date; and (d) all Related Cases (whether pending, issued, abandoned or filed before or after the effective date of this assignment) and foreign counterparts to any or all of the foregoing, including utility models, certificates of invention and equivalent rights worldwide; such right, title and interest further includes without limitation all rights to claim priority on the basis thereof, all rights to sue for past, present and future infringement, including the right to collect and receive any damages, royalties, or settlements for such infringements, all rights to sue for injunctive or other equitable relief, and any and all causes of action relating to any of the inventions or discoveries thereof;

Assignor hereby covenants that it has full right to convey the entire interest herein assigned, and that it has not executed, and will not execute, any agreement in conflict with this Assignment;

Assignor hereby further covenants and agrees that it will communicate to ASSIGNEE any and all facts known to it respecting said patents, and testify in any legal proceeding, sign all lawful papers, execute and deliver all papers and take any actions that may be necessary or desirable to perfect the title to any aforementioned patents and inventions, execute all divisional, continuation, reexamination, reissue and substitute applications, and make all rightful oaths and generally do everything possible to aid ASSIGNEE to obtain and enforce proper patent protection for said inventions in all countries.

FOR USPTO RECORDING

COPY- DO NOT RECORD

IN TESTIMONY WHEREOF, I hereunto set my hand this 27 day of March,
2015.

NOKIA SOLUTIONS AND NETWORKS OY
(Assignor)

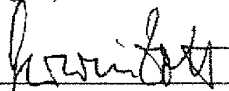
By 

Name: Gerwin Zott
Authorized Signatory

Title: Authorized Signatory

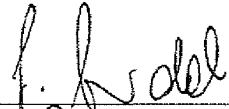
By 

Name: G. WEIDEL

Title: Authorized Signatory

WITNESSED BY:

By 

Name: Gerald Host

COPY- DO NOT RECORD

Schedule I
Nokia Solutions and Networks Oy

Internal file number	Filing date	Application number	Publication number	Grant date	Grant number	Applicant / Name
2007P02706WE	23.06.2008	08775509.6	2171871			Nokia Solutions and Networks Oy
2007P02706WOAU	23.06.2008	2008265071	2008265071	15.07.2013	2008265071	Nokia Solutions and Networks Oy
2007P02706WOBR	23.06.2008	PI0814714-0				Nokia Siemens Networks Oy
2007P02706WOCA	23.06.2008	2691230				Nokia Siemens Networks Oy
2007P02706WOCN	23.06.2008	200880103990.4	101785206			Nokia Solutions and Networks Oy
2007P02706WOIN	23.06.2008	8416/DELNP/2009				Nokia Siemens Networks Oy
2007P02706WOJP	23.06.2008	2010-512729		29.03.2013	5232224	Nokia Solutions and Networks Oy
2007P02706WOKR	23.06.2008	2010-7001337	2010-0041775	24.10.2011	1078115	Nokia Solutions and Networks Oy
2007P02706WOMX	23.06.2008	2009/014083		01.04.2011	285392	Nokia Siemens Networks Oy
2007P02706WORU	23.06.2008	2010101598		20.08.2013	2490795	Nokia Siemens Networks Oy
2007P02706WOUS	23.06.2008	12/665,427	2010-0173665	04.06.2013	8457676	Nokia Solutions and Networks Oy
2007P02706WOZA	23.06.2008	2009/09102		25.08.2010	2009/09102	Nokia Siemens Networks Oy
2007P03110 TH	07.08.2008	0801004122	98245			Nokia Siemens Networks Oy
2007P03110 TW	07.08.2008	97129980	200924542	21.06.2014	1442804	Nokia Siemens Networks Oy
2007P03110EPDE	09.08.2007	07015719.3	2023683	18.05.2011	60 2007 014 671.2	Nokia Solutions and Networks Oy
2007P03110EPFR	09.08.2007	07015719.3	2023683	18.05.2011	2023683	Nokia Siemens Networks Oy
2007P03110EPGB	09.08.2007	07015719.3	2023683	18.05.2011	2023683	Nokia Solutions and Networks Oy
2007P03110WOAU	31.07.2008	2008285753		26.04.2013	2008285753	Nokia Solutions and Networks Oy
2007P03110WOBR	31.07.2008	PI0814959-3				Nokia Siemens Networks Oy
2007P03110WOCN	31.07.2008	200880110723.X	101822116			Nokia Solutions and Networks Oy
2007P03110WOIN	31.07.2008	772/DELNP/2010				Nokia Siemens Networks Oy
2007P03110WOMX	31.07.2008	2010/001521		03.04.2012	297840	Nokia Siemens Networks Oy
2007P03110WOUS	31.07.2008	12/733,134	2010-0285791			Nokia Solutions and Networks Oy
2007P03923EP	30.10.2007	07119645.5	2056515			Nokia Solutions and Networks Oy
2007P03923WOCN	20.10.2008	200880123540.1	101911580	26.02.2014	101911580	Nokia Solutions and Networks Oy
2007P03923WOIN	20.10.2008	3172/DELNP/2010				Nokia Siemens Networks Oy
2007P03923WORU	20.10.2008	2010121542		10.10.2012	2463714	Nokia Siemens Networks Oy
2007P03923WOUS	20.10.2008	12/734,430	2010-0296465	19.02.2013	8379590	Nokia Solutions and Networks Oy
2007P04166EP	13.11.2007	07022036.3	2061212			Nokia Solutions and Networks Oy
2007P04166WOAU	30.10.2008	2008323081		03.04.2014	2008323081	Nokia Solutions and Networks Oy
2007P04166WOBR	30.10.2008	PI0820525-6				Nokia Siemens Networks Oy
2007P04166WOCN	30.10.2008	200880116575.2	101855890	16.04.2014	101855890	Nokia Solutions and Networks Oy

COPY- DO NOT RECORD

Schedule I
Nokia Solutions and Networks Oy

2007P04166WOUS	30.10.2008	12/742,102	2010-0257273			Nokia Solutions and Networks Oy
2007P04166WOZA	30.10.2008	2010/02340		29.12.2010	2010/02340	Nokia Siemens Networks Oy
2007P04291 US01	26.11.2008	12/315,128	2009-0156208			Nokia Solutions and Networks Oy
2007P04291WE	26.11.2008	08855116.3	2229796			Nokia Solutions and Networks Oy
2007P04291WOAU	26.11.2008	2008328876		28.11.2013	2008328876	Nokia Solutions and Networks Oy
2007P04291WOBR	26.11.2008	PI0819635-4				Nokia Siemens Networks Oy
2007P04291WOCA	26.11.2008	2706641		28.01.2014	2706641	Nokia Siemens Networks Oy
2007P04291WOCN	26.11.2008	200880125565.5	101926202	24.12.2014	101926202	Nokia Solutions and Networks Oy
2007P04291WOIN	26.11.2008	4137/DELNP/2010				Nokia Siemens Networks Oy
2007P04291WOJP	26.11.2008	2010-535367	2011-504716	12.07.2013	5314699	Nokia Solutions and Networks Oy
2007P04291WOKR	26.11.2008	2010-7014102	2010-0093096	06.03.2012	1126461	Nokia Solutions and Networks Oy
2007P04291WORU	26.11.2008	2010125955		10.04.2012	2447619	Nokia Siemens Networks Oy
2008P00892 SG01	26.03.2009	201304022-5	191605			Nokia Solutions and Networks Oy
2008P00892 US01	26.03.2009	12/382,920	2009-0245191	29.10.2013	8570957	Nokia Solutions and Networks Oy
2008P00892WE	26.03.2009	09724253.1	2260664			Nokia Solutions and Networks Oy
2008P00892WOAU	26.03.2009	2009228928		17.07.2014	2009228928	Nokia Solutions and Networks Oy
2008P00892WOCN	26.03.2009	200980119369.1	102047736			Nokia Solutions and Networks Oy
2008P00892WOIN	26.03.2009	6880/DELNP/2010				Nokia Siemens Networks Oy
2008P00892WORU	26.03.2009	2010143473		27.02.2013	2477000	Nokia Siemens Networks Oy
2008P01573WE	24.06.2008	08761329.5	2298004			Nokia Solutions and Networks Oy
2008P01573WOCN	24.06.2008	200880130857.8	102132610			Nokia Solutions and Networks Oy
2008P01573WOIN	24.06.2008	9061/DELNP/2010				Nokia Siemens Networks Oy
2008P01573WOJP	24.06.2008	2011-513887	2011-525738	26.04.2013	5256343	Nokia Solutions and Networks Oy
2008P01573WOKR	24.06.2008	2011-7001826	2011-0022708	18.12.2012	1215452	Nokia Solutions and Networks Oy
2008P01573WOUS	24.06.2008	13/000,719	2011-0129008	02.09.2014	8824533	Nokia Solutions and Networks Oy
2008P01741 KR01	30.06.2009	2012-7012679		07.06.2013	1274663	Nokia Solutions and Networks Oy
2008P01741 US01	30.06.2009	12/459,352	2009-0323613	12.03.2013	8396030	Nokia Solutions and Networks Oy
2008P01741 US02	19.02.2013	13/770,384	2013-0163546	14.10.2014	8861472	Nokia Solutions and Networks Oy
2008P01741 US03	22.08.2014	14/465,954	2014-0362707			Nokia Solutions and Networks Oy
2008P01741WE	30.06.2009	09772443.9	2297893			Nokia Solutions and Networks Oy
2008P01741WOAU	30.06.2009	2009265740		24.10.2013	2009265740	Nokia Solutions and Networks Oy
2008P01741WOBR	30.06.2009	PI0914115-4				Nokia Siemens Networks Oy
2008P01741WOCA	30.06.2009	2729510				Nokia Siemens Networks Oy

COPY- DO NOT RECORD

Schedule I
Nokia Solutions and Networks Oy

2008P01741WOCN	30.06.2009	200980133571.X	102144367	31.07.2013	1245344	Nokia Solutions and Networks Oy
2008P01741WOIN	30.06.2009	9298/DELNP/2010				Nokia Siemens Networks Oy
2008P01741WOJP	30.06.2009	2011-515434	2011-527843	18.10.2013	5391275	Nokia Solutions and Networks Oy
2008P01741WOKR	30.06.2009	2011-7002550	2011-0025874	31.10.2012	1198472	Nokia Solutions and Networks Oy
2008P01741WOPH	30.06.2009	1-2010-502939		12.12.2013	1-2010-502939	Nokia Siemens Networks Oy
2008P01741WORU	30.06.2009	2011102801		20.08.2013	2490803	Nokia Siemens Networks Oy
2008P01741WOSG	30.06.2009	201009651-9		31.07.2013	167965	Nokia Solutions and Networks Oy
2008P01741WOZA	30.06.2009	2011/00012		04.08.2011	2011/00012	Nokia Siemens Networks Oy
2008P02428 US01	22.09.2009	12/564,536		04.06.2013	8457022	Nokia Solutions and Networks Oy
2008P02428 US02	22.09.2009	13/744,079				Nokia Solutions and Networks Oy
2008P02428WEAT	22.09.2009	09783280.2	2342858	02.01.2013	E592106	Nokia Siemens Networks Oy
2008P02428WECH	22.09.2009	09783280.2	2342858	02.01.2013	2342858	Nokia Solutions and Networks Oy
2008P02428WEDE	22.09.2009	09783280.2	2342858	02.01.2013	60 2009 012 542.7	Nokia Solutions and Networks Oy
2008P02428WEDK	22.09.2009	09783280.2	2342858	02.01.2013	2342858	Nokia Solutions and Networks Oy
2008P02428WEES	22.09.2009	09783280.2	2342858	02.01.2013	2342858	Nokia Solutions and Networks Oy
2008P02428WEFI	22.09.2009	09783280.2	2342858	02.01.2013	2342858	Nokia Solutions and Networks Oy
2008P02428WEFR	22.09.2009	09783280.2	2342858	02.01.2013	2342858	Nokia Siemens Networks Oy
2008P02428WEGB	22.09.2009	09783280.2	2342858	02.01.2013	2342858	Nokia Solutions and Networks Oy
2008P02428WEIT	22.09.2009	09783280.2	2342858	02.01.2013	2342858	Nokia Siemens Networks Oy
2008P02428WENL	22.09.2009	09783280.2	2342858	02.01.2013	2342858	Nokia Siemens Networks Oy
2008P02428WEPL	22.09.2009	09783280.2	2342858	02.01.2013	2342858	Nokia Siemens Networks Oy
2008P02428WESE	22.09.2009	09783280.2	2342858	02.01.2013	2342858	Nokia Solutions and Networks Oy
2008P02428WETR	22.09.2009	09783280.2	2342858	02.01.2013	TR201303709T4	Nokia Siemens Networks Oy
2008P02428WOAU	22.09.2009	2009294519				Nokia Solutions and Networks Oy
2008P02428WOBR	22.09.2009	PI 0918762-6				Nokia Siemens Networks Oy
2008P02428WOCA	22.09.2009	2737664				Nokia Siemens Networks Oy
2008P02428WOCN	22.09.2009	200980146400.0	102224701	05.11.2014	102224701	Nokia Solutions and Networks Oy
2008P02428WOCN01	22.09.2009	201410397749.4	104135354			Nokia Siemens Networks Oy
2008P02428WOIN	22.09.2009	2888/DELNP/2011				Nokia Siemens Networks Oy
2008P02428WOJP	22.09.2009	2011-527352	2012-503393	05.07.2013	5308530	Nokia Solutions and Networks Oy
2008P02428WOKR	22.09.2009	2011-7009298	2011-0060952	26.04.2013	1260348	Nokia Solutions and Networks Oy
2008P02428WOMY	22.09.2009	PI 2011001244				Nokia Siemens Networks Oy
2008P02428WORU	22.09.2009	2011115532		10.12.2012	2469476	Nokia Siemens Networks Oy

COPY- DO NOT RECORD

Schedule I
Nokia Solutions and Networks Oy

2008P02428WOSG	22.09.2009	201101924-7		30.09.2013	169721	Nokia Solutions and Networks Oy
2008P02428WOZA	22.09.2009	2011/01889		30.11.2011	2011/01889	Nokia Siemens Networks Oy
2008P02543WE	26.09.2008	08807831.6	2332358			Nokia Solutions and Networks Oy
2008P02543WOCN	26.09.2008	200880132102.1	102227928	24.12.2014	102227928	Nokia Solutions and Networks Oy
2008P02543WOIN	26.09.2008	2177/DELNP/2011				Nokia Siemens Networks Oy
2008P02543WOKR	26.09.2008	2011-7009502	2011-0082011	27.03.2013	1249897	Nokia Solutions and Networks Oy
2008P02543WOUS	26.09.2008	13/120,947	2011-01836647			Nokia Solutions and Networks Oy
2008P02630WE	15.01.2009	09778955.6	2387830			Nokia Solutions and Networks Oy
2008P02630WOUS	15.01.2009	13/144,562	2011-0275392			Nokia Solutions and Networks Oy
2008P02993 US02	03.02.2010	12/699,146	2010-0197339	17.07.2012	8224372	Nokia Solutions and Networks Oy
2008P02993 US03	06.06.2012	13/489,870	2012-0314666	21.05.2013	8447345	Nokia Solutions and Networks Oy
2008P02993WE	02.02.2010	10702667.6	2394472			Nokia Solutions and Networks Oy
2008P03085 US01	12.09.2008	12/283,447	2009-0103561	09.11.2010	7830916	Nokia Solutions and Networks Oy
2008P03085WE	12.09.2008	08807635.1	2204005			Nokia Solutions and Networks Oy
2008P03085WOCN	12.09.2008	200880116589.4	101855859	16.07.2014	101855859	Nokia Solutions and Networks Oy
2008P03085WORU	12.09.2008	2010114720		20.06.2013	2485700	Nokia Siemens Networks Oy
2009P01594WE	16.10.2009	09850348.5	2489213			Nokia Solutions and Networks Oy
2009P01594WOCN	16.10.2009	200980162642.9				Nokia Solutions and Networks Oy
2009P01594WOIN	16.10.2009	3274/DELNP/2012				Nokia Siemens Networks Oy
2009P01594WOJP	16.10.2009	2012-533454	2013-507852			Nokia Solutions and Networks Oy
2009P01594WOKR	16.10.2009	2012-7012659	2012-0085813			Nokia Solutions and Networks Oy
2009P01594WOUS	16.10.2009	13/502,236	2012-0236798			Nokia Solutions and Networks Oy
2010P01813 US01	28.09.2011	13/247,323	2012-0076088	02.12.2014	8902770	Nokia Solutions and Networks Oy
2010P01813 US02	28.09.2011	14/558,083				Nokia Siemens Networks Oy
2010P01819 US01	05.10.2011	13/253,323	2012-0093012			Nokia Solutions and Networks Oy
2010P01819WE	05.10.2011	11764562.2	2625911			Nokia Solutions and Networks Oy
2010P01819WOBR	05.10.2011	11 2013 008193 7				Nokia Siemens Networks Oy
2010P01819WOCA	05.10.2011	2813275				Nokia Siemens Networks Oy
2010P01819WOCN	05.10.2011	201180048119.0	CN 103155672 A			Nokia Solutions and Networks Oy
2010P01819WOID	05.10.2011	W-00201301392	03951			Nokia Siemens Networks Oy
2010P01819WOIN	05.10.2011	2401/DELNP/2013				Nokia Siemens Networks Oy
2010P01819WOJP	05.10.2011	2013-532181	2013-545341			Nokia Solutions and Networks Oy
2010P01819WOKR	05.10.2011	2013-7011638				Nokia Solutions and Networks Oy

COPY- DO NOT RECORD

Schedule I
Nokia Solutions and Networks Oy

2010P01819WOMX	05.10.2011	2013/003867				Nokia Siemens Networks Oy
2010P01819WORU	05.10.2011	2013119339				Nokia Siemens Networks Oy
2010P01819WOSG	05.10.2011	201302164-7				Nokia Solutions and Networks Oy
2010P02547 HK	22.10.2014	14110540.8	1197324			Nokia Solutions and Networks Oy
2010P02547 TW	13.08.2012	101129179	201320680			Nokia Siemens Networks Oy
2010P02547WE	15.08.2011	11743239.3	2745452			Nokia Solutions and Networks Oy
2010P02547WOAU	15.08.2011	2011375165				Nokia Solutions and Networks Oy
2010P02547WOBR	15.08.2011	1120140035792				Nokia Solutions and Networks Oy
2010P02547WOCN	15.08.2011	201180072631.9	103858376			Nokia Solutions and Networks Oy
2010P02547WOID	15.08.2011	P-00201400511				Nokia Solutions and Networks Oy
2010P02547WOIN	15.08.2011	11168/DELNP/2013				Nokia Solutions and Networks Oy
2010P02547WOJP	15.08.2011	2014-525326	2014-529218			Nokia Solutions and Networks Oy
2010P02547WOKR	15.08.2011	2014-7006927	2014-0053334			Nokia Solutions and Networks Oy
2010P02547WORU	15.08.2011	2014108743				Nokia Solutions and Networks Oy
2010P02547WOSG	15.08.2011	201400104-4				Nokia Solutions and Networks Oy
2010P02547WOUS	15.08.2011	14/238,518	2014-0204961			Nokia Solutions and Networks Oy
2010P02561WE	18.01.2011	11856441.8	2666261			Nokia Solutions and Networks Oy
2010P02561WOAU	18.01.2011	2011356544				Nokia Solutions and Networks Oy
2010P02561WOBR	18.01.2011	1120130178914				Nokia Siemens Networks Oy
2010P02561WOCN	18.01.2011	201180065273.9	103314553			Nokia Solutions and Networks Oy
2010P02561WOHK	18.01.2011	14102681.4	1189724			Nokia Solutions and Networks Oy
2010P02561WOID	18.01.2011	W-00201303187				Nokia Siemens Networks Oy
2010P02561WOIN	18.01.2011	5552/DELNP/2013				Nokia Siemens Networks Oy
2010P02561WOJP	18.01.2011	2013-549688	2014-507870			Nokia Solutions and Networks Oy
2010P02561WOKR	18.01.2011	2013-7021660	2013-0129424			Nokia Solutions and Networks Oy
2010P02561WOPH	18.01.2011	1-2013-501274				Nokia Siemens Networks Oy
2010P02561WORU	18.01.2011	2013138235				Nokia Siemens Networks Oy
2010P02561WOUS	18.01.2011	13/980,323	2013-0295950			Nokia Solutions and Networks Oy
2011P01131 US	10.08.2011	13/136,793	2013-0040605	27.05.2014	8738075	Nokia Solutions and Networks Oy
2011P01131 US01	16.05.2014	14/280,077	2014-0248874	03.02.2015	8948751	Nokia Solutions and Networks Oy
2011P01131WE	16.07.2012	12737775.2	2742734			Nokia Solutions and Networks Oy
2011P01131WOCN	16.07.2012	201280038854.8	103733688			Nokia Solutions and Networks Oy

COPY- DO NOT RECORD



UNITED STATES PATENT AND TRADEMARK OFFICE

UNITED STATES DEPARTMENT OF COMMERCE
United States Patent and Trademark Office
Address: COMMISSIONER FOR PATENTS
P.O. Box 1450
Alexandria, Virginia 22313-1450
www.uspto.gov

APPLICATION NUMBER	FILING OR 371(C) DATE	FIRST NAMED APPLICANT	ATTY. DOCKET NO./TITLE
12/665,427	01/22/2010	Juergen Michel	863.0156.U1(US)

CONFIRMATION NO. 1011

POA ACCEPTANCE LETTER

27189
PROCOPIO, CORY, HARGREAVES & SAVITCH LLP
525 B STREET
SUITE 2200
SAN DIEGO, CA 92101



Date Mailed: 04/09/2015

NOTICE OF ACCEPTANCE OF POWER OF ATTORNEY

This is in response to the Power of Attorney filed 04/03/2015.

The Power of Attorney in this application is accepted. Correspondence in this application will be mailed to the above address as provided by 37 CFR 1.33.

/hsarwari/

Office of Data Management, Application Assistance Unit (571) 272-4000, or (571) 272-4200, or 1-888-786-0101



UNITED STATES PATENT AND TRADEMARK OFFICE

UNITED STATES DEPARTMENT OF COMMERCE
United States Patent and Trademark Office
Address: COMMISSIONER FOR PATENTS
P.O. Box 1450
Alexandria, Virginia 22313-1450
www.uspto.gov

APPLICATION NUMBER	FILING OR 371(C) DATE	FIRST NAMED APPLICANT	ATTY. DOCKET NO./TITLE
12/665,427	01/22/2010	Juergen Michel	863.0156.U1(US)

29683
HARRINGTON & SMITH
4 RESEARCH DRIVE, Suite 202
SHELTON, CT 06484-6212

CONFIRMATION NO. 1011
POWER OF ATTORNEY NOTICE



Date Mailed: 04/09/2015

NOTICE REGARDING CHANGE OF POWER OF ATTORNEY

This is in response to the Power of Attorney filed 04/03/2015.

- The Power of Attorney to you in this application has been revoked by the assignee who has intervned as provided by 37 CFR 3.71. Future correspondence will be mailed to the new address of record(37 CFR 1.33).

/hsarwari/

Office of Data Management, Application Assistance Unit (571) 272-4000, or (571) 272-4200, or 1-888-786-0101

SPE RESPONSE FOR CERTIFICATE OF CORRECTION

DATE : 04/30/2015

TO SPE OF : ART UNIT 2647

SUBJECT : Request for Certificate of Correction for Appl. No.: 12/665,427 Patent No.: 8,457,676 B2

CofC mailroom date: 03/03/2015

Please respond to this request for a certificate of correction within 7 days.

FOR IFW FILES:

Please review the requested changes/corrections as shown in the **COCIN** document(s) in the IFW application image. No new matter should be introduced, nor should the scope or meaning of the claims be changed.

Please complete the response (see below) and forward the completed response to scanning using document code **COCX**.

FOR PAPER FILES:

Please review the requested changes/corrections as shown in the attached certificate of correction. Please complete this form (see below) and forward it with the file to:

**Certificates of Correction Branch (CofC)
Randolph Square – 9D10-A
Palm Location 7580**

Note: In the claims

Virginia Tolbert

**Certificates of Correction Branch
(571) 272-0460**

Thank You For Your Assistance

The request for issuing the above-identified correction(s) is hereby:

Note your decision on the appropriate box.

- | | |
|--------------------------------------------------|--------------------------------------------------|
| <input type="checkbox"/> Approved | All changes apply. |
| <input type="checkbox"/> Approved in Part | Specify below which changes do not apply. |
| <input type="checkbox"/> Denied | State the reasons for denial below. |

Comments: _____

SPE RESPONSE FOR CERTIFICATE OF CORRECTION

DATE : 04/30/2015
TO SPE OF : ART UNIT 2647
SUBJECT : Request for Certificate of Correction for Appl. No.: 12/665,427 Patent No.: 8,457,676 B2

CofC mailroom date: 03/03/2015

Please respond to this request for a certificate of correction within 7 days.

FOR IFW FILES:

Please review the requested changes/corrections as shown in the **COCIN** document(s) in the IFW application image. No new matter should be introduced, nor should the scope or meaning of the claims be changed.

Please complete the response (see below) and forward the completed response to scanning using document code **COCX**.

FOR PAPER FILES:

Please review the requested changes/corrections as shown in the attached certificate of correction. Please complete this form (see below) and forward it with the file to:

Certificates of Correction Branch (CofC)
Randolph Square – 9D10-A
Palm Location 7580

Note: In the claims

Virginia Tolbert

Certificates of Correction Branch
(571) 272-0460

Thank You For Your Assistance

The request for issuing the above-identified correction(s) is hereby:

Note your decision on the appropriate box.

Approved

All changes apply.

Approved in Part

Specify below which changes do not apply.

Denied

State the reasons for denial below.

Comments: _____

/Nay A. Maung/

AU2647

UNITED STATES PATENT AND TRADEMARK OFFICE
CERTIFICATE OF CORRECTION

PATENT NO. : 8,457,676 B2
APPLICATION NO. : 12/665427
DATED : June 4, 2013
INVENTOR(S) : Juergen Michel et al.

Page 1 of 1

It is certified that error appears in the above-identified patent and that said Letters Patent is hereby corrected as shown below:

In the Claims

Column 9, line 20 thru Column 10, line 7

Strike the phrase “, wherein the set of at least one triggering criterion comprises a criterion being met based on reaching a threshold of the at least one threshold of k transmission time intervals following a previous power control headroom report, wherein k is an integer and wherein said at least one threshold adjustable via the signal comprises adjusting the threshold integer k” from lines 10-17 of claim 33, and insert the phrase --; wherein the set of at least one triggering criterion comprises a criterion being met based on reaching a threshold of the at least one threshold of k transmission time intervals following a previous power control headroom report, wherein k is an integer and wherein said at least one threshold adjustable via the signal comprises adjusting the threshold integer k-- after the phrase “provide a threshold adjustment signal to the user equipment in order to adjust the at least one threshold” at line 19 of claim 33.

Signed and Sealed this
Seventh Day of July, 2015



Michelle K. Lee
Director of the United States Patent and Trademark Office