

(12) **United States Patent**
Bhogal et al.

(10) **Patent No.:** **US 6,629,197 B1**
(45) **Date of Patent:** **Sep. 30, 2003**

(54) **METHOD AND SYSTEM FOR STORING DIGITAL AUDIO DATA AND EMULATING MULTIPLE CD-CHANGER UNITS**

6,137,047 A * 10/2000 Sugiyama 84/626
6,137,677 A * 10/2000 Ganthier et al. 361/683
6,182,242 B1 * 1/2001 Brogan et al. 714/26

(75) Inventors: **Kulvir Singh Bhogal**, Austin, TX (US);
Nizamudeen Ishmael, Jr., Austin, TX (US);
Baljeet Singh Baweja, Austin, TX (US);
Mandeep Sidhu, Austin, TX (US)

FOREIGN PATENT DOCUMENTS

DE 019546380 A1 * 6/1996 G06F/13/12
DE 29921681 12/1999
EP 999549 A2 11/1999
JP 403192426 A * 8/1991 G06F/3/06
JP 07271525 A * 10/1995 G06F/3/08
WO WO 00/11793 3/2000

(73) Assignee: **International Business Machines Corporation**, Armonk, NY (US)

OTHER PUBLICATIONS

(*) Notice: Subject to any disclaimer, the term of this patent is extended or adjusted under 35 U.S.C. 154(b) by 0 days.

English translation of DE 19546380.*
"Audio Services Repair Forum—computer emulated cd changer", <http://www.djcafe.com>, Oct. 9, 1999.
"The CrazyKarl.com Car MP3 Player", <http://www.krazykarl.com/mp3car>, Aug. 18, 2000.
"Aiwa car CD-MP3 player", <http://slashdot.org>, May 6, 2000.
Moore, "How Do I Create a Streaming Audio Java Applet?", Dr. Dobb's Journal, v. 23, n. 5, pp. 122-124, May 1998.

(21) Appl. No.: **09/704,570**

(22) Filed: **Nov. 3, 2000**

(51) **Int. Cl.**⁷ **G06F 12/00**

(52) **U.S. Cl.** **711/111; 711/163; 711/164; 369/2; 369/6; 709/219; 703/24**

(58) **Field of Search** **369/1, 2, 6, 7; 703/24, 25; 711/111, 163, 164; 709/219**

* cited by examiner

Primary Examiner—Aristotelis M. Psitos

(74) *Attorney, Agent, or Firm*—Jeffrey S. LaBaw; Joseph R. Burwell

(56) **References Cited**

U.S. PATENT DOCUMENTS

5,131,089 A * 7/1992 Cole 703/24
5,161,131 A 11/1992 Borchardt et al. 369/1
5,235,568 A 8/1993 Masaru 369/2
5,253,218 A * 10/1993 Suzuki 369/75.1
5,339,362 A * 8/1994 Harris 381/86
5,457,677 A * 10/1995 Yamashita et al. 369/289
5,473,765 A * 12/1995 Gibbons et al. 703/24
5,475,836 A * 12/1995 Harris et al. 703/24 X
5,633,843 A * 5/1997 Gupta et al. 369/32
5,640,592 A * 6/1997 Rao 395/825
5,790,481 A 8/1998 Meitner 369/2
5,794,013 A * 8/1998 McBrearty 395/500
6,011,741 A * 1/2000 Wallace et al. 365/221
6,028,996 A * 2/2000 Sniderman et al. 703/28
6,035,116 A * 3/2000 Terada et al. 703/24
6,041,023 A 3/2000 Lakhansingh 369/7
6,055,478 A * 4/2000 Heron 701/213
6,061,306 A 5/2000 Buchheim 369/2
6,117,186 A * 9/2000 Wydall et al. 717/9

(57) **ABSTRACT**

A method for processing digital audio data is presented. A control signal for a CD-changer unit is received and interpreted by a digital audio unit that stores digital audio data/files and that determines a CD-changer unit operation that would be performed by the CD-changer unit in response to the CD-changer unit receiving the control signal. The digital audio unit then emulates the CD-changer unit operation. The CD-changer unit to be emulated by the digital audio unit can be selected. The digital audio data stored by the digital audio unit can be organized as virtual CD-ROMs. By emulating the operations of multiple types of CD-changer units, a single digital audio unit can be inserted in many different digital audio systems, thereby extending the functionality of a digital audio system to include storage of softcopy digital audio files that may be accessed through controls and commands for a CD-changer unit.

17 Claims, 3 Drawing Sheets

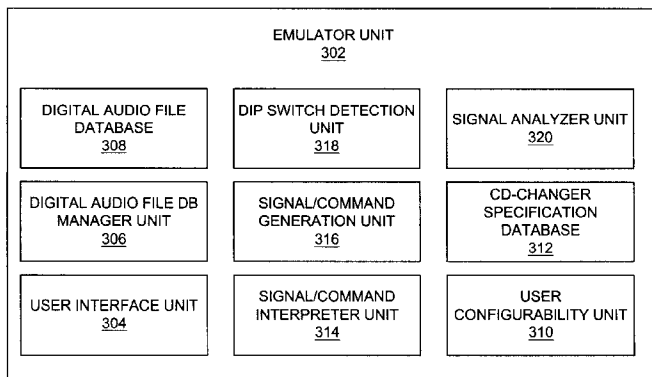

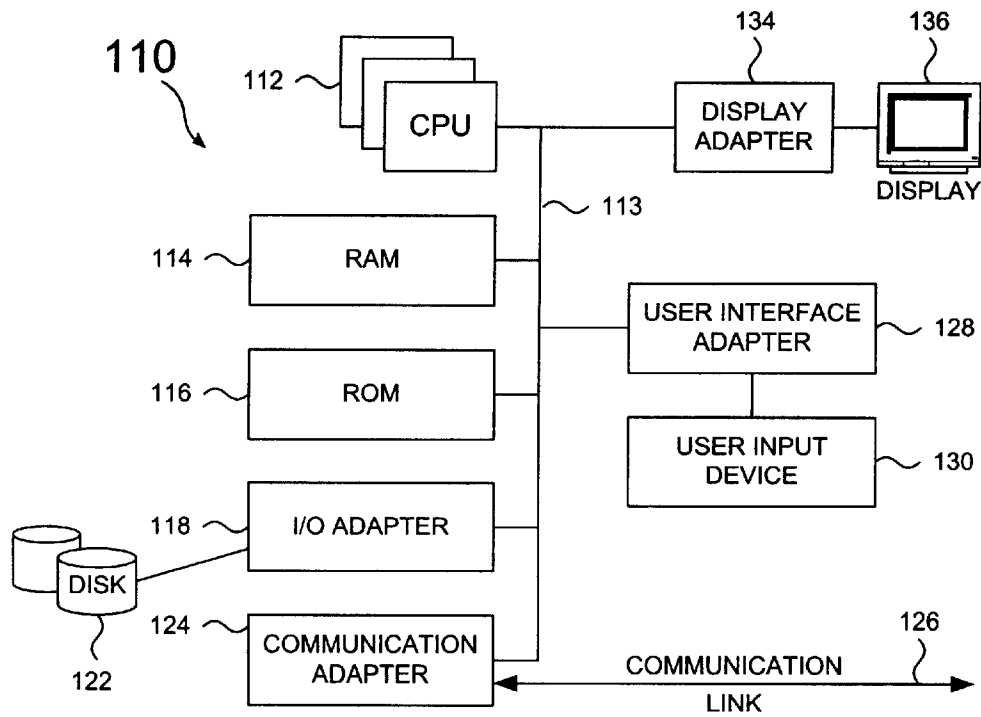

FIG. 1

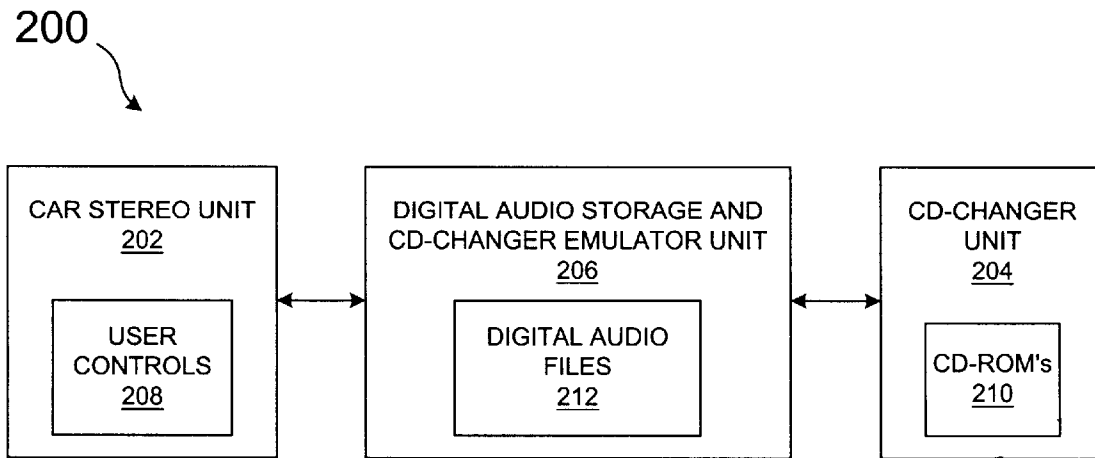

FIG. 2

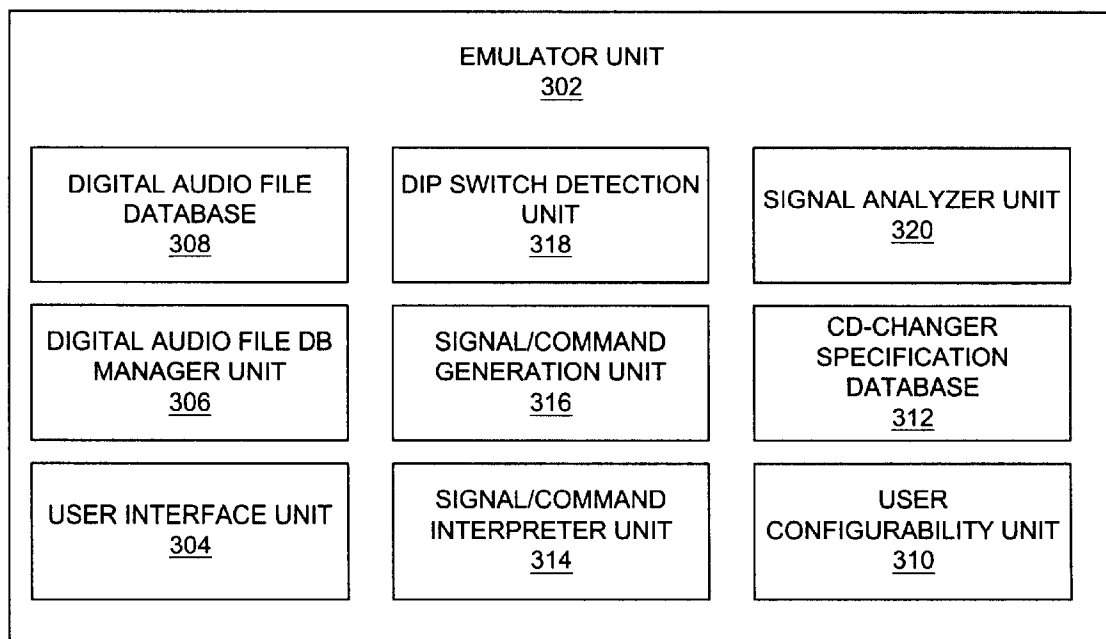

FIG. 3

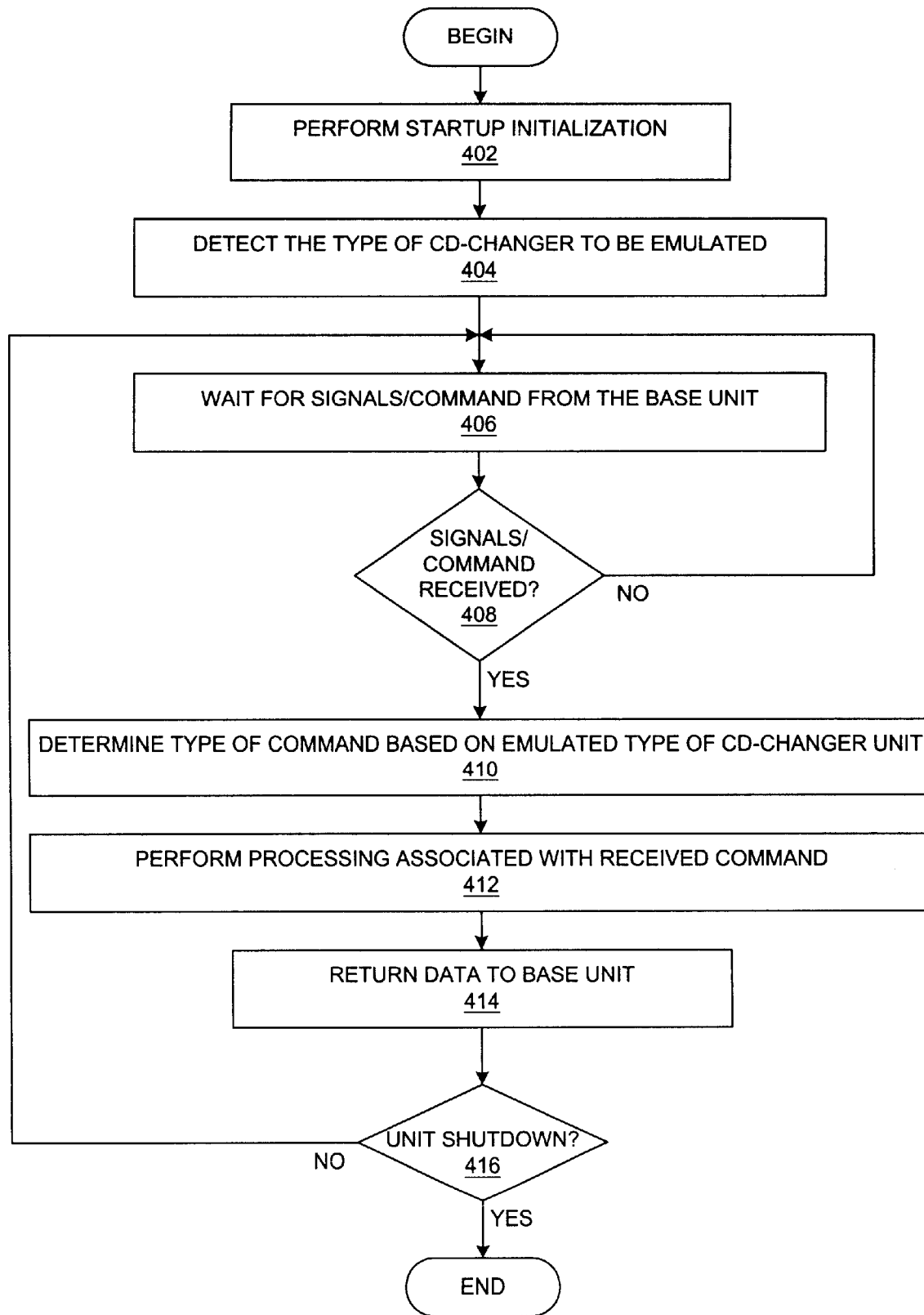

FIG. 4

METHOD AND SYSTEM FOR STORING DIGITAL AUDIO DATA AND EMULATING MULTIPLE CD-CHANGER UNITS

BACKGROUND OF THE INVENTION

1. Field of the Invention

The present invention relates to an improved data processing system and, in particular, to a method and apparatus for enhancing storage and playback of digital audio data.

2. Description of Related Art

While portable CD players have been widely available for many years, other types of digital audio devices, applications, and services have recently become very popular. CD-ROM players are standard equipment on many personal computers, and many free or commercially available applications allow a user to record digital audio data from a CD onto the hard drive of a personal computer.

Internet connections have also become standard features on most home computers. With the expanding commercial uses of the Internet, many new applications and devices have been developed and are being developed that connect to the Internet and use the Internet in a variety of ways. With the increasing availability of broadband connections, many home computers now have the ability to transmit and receive large amounts of data with relative ease. As a consequence, large digital audio files are now commonly transmitted across the Internet. In addition, many software applications and services are available for allowing users to buy and/or share digital audio files.

As with many digital appliances and devices, portable digital audio devices have become Internet-enabled in some manner. Relatively inexpensive portable devices now provide the ability to store large amounts of digital audio data in standard or flash random access memory (RAM). Typically, the digital audio data has been downloaded from the Internet or recorded from a CD onto a hard drive of a personal computer, and the digital audio data is then transferred into the digital audio device or into a flash RAM component that is subsequently placed into the digital audio device.

Although other data formats are also popular, the most popular file format for digital audio data is MP3, a form of MPEG-3 compression and encoding. Hence, as shorthand or slang, many portable digital audio devices are known as MP3 players. MP3 files can be downloaded through the Internet and stored into an MP3 player.

With the popularity of the MP3 file format and other types of digital audio files, many traditional types of digital audio equipment are being enhanced to receive and store digital audio files. Home stereos and car stereos are now manufactured with the capability of either directly storing and playing digital audio files and/or interfacing with digital audio storage devices, such as MP3 players.

While many people have become accustomed to purchasing new digital devices with the newest capabilities, many people are disappointed with the trend of replacing devices that are otherwise fully functional except for the fact that the older devices do not have the newest functionality. For example, a user may own a relatively new car stereo system that contains a sophisticated CD changer unit with digital radio capability for so-called satellite broadcast, CD-quality radio. However, the user may now frequently use a newer portable digital audio device, such as an MP3 player, and because the car stereo system lacks an interface for the

portable digital audio device, this user might become frustrated from the inability to play digital audio files through the car stereo system.

Essentially, the user is required to deal with digital audio files stored in different formats that can only be used on certain equipment. The user may continue to use CDs from a CD collection in a personal computer, home stereo, and car stereo. The user may also record digital audio files from a personal CD collection to create a digital audio file library, which is enhanced with files purchased or legally shared and downloaded from the Internet. The library of digital audio files might be archived on a personal computer, but these files can be temporarily copied to a portable digital audio device.

Once a user has built a personal digital audio file library, the user may become frustrated with the inability to playback digital audio files on certain equipment. For example, a user may be required to remember which digital audio files are owned only in a CD-ROM format. The user must then physically transfer CD-ROMs between locations when the user desires to playback the digital audio on these CDs in different locations. Data in hardcopy format, such as CDs, is becoming increasingly inconvenient in a computing environment in which devices are continually connected via the Internet and in which data can be easily transferred in softcopy format.

In order to reduce the number of times in which a user must physically transfer CDs to and from an audio system, many users have enhanced audio systems with a CD-changer unit that stores many audio CDs and that allows another piece of equipment in the audio system to control the CD-changer unit. In contrast to an audio unit that receives and plays a single CD, the CD-changer unit acts as a jukebox for storing, choosing, and playing many CDs. The user then has easy access to playing many CDs at any given time.

The CDs stored within a CD-changer unit, however, might represent only a small subset of the user's digital audio library. The user is still required to physically transfer the digital audio files in a physical medium, i.e. the CD-ROMs. When compared with the ease of transferring and using digital audio files in softcopy format with certain types of equipment, one can understand the inconvenience of continuing to use a CD library in hardcopy format. This is particularly frustrating given the widely held assumption that CDs were to be the ultimate format for storing and playing digital audio.

Currently owned audio equipment may be adequate except for the fact that the audio equipment does not have the ability to receive, store, or play digital audio files that are available only in softcopy format. Updating an audio system by replacing audio equipment in this situation seems expensive and unnecessary. Many audiophiles desire an alternative solution that allows them to keep their presently-owned audio equipment while updating the system with new functionality for receiving, storing, or playing digital audio files in softcopy format. This situation is particularly true for those persons who have previously purchased expensive CD-changer units that were widely regarded as necessary equipment for easy access to CDs.

Therefore, it would be advantageous to provide a system in which audio equipment can be enhanced with functionality for receiving, storing, or playing digital audio files in softcopy format. It would be particularly advantageous to augment an existing system containing a CD-changer unit with the desired functionality without having to physically modify the equipment in the existing audio system.

Explore Litigation Insights

Docket Alarm provides insights to develop a more informed litigation strategy and the peace of mind of knowing you're on top of things.

Real-Time Litigation Alerts



Keep your litigation team up-to-date with **real-time alerts** and advanced team management tools built for the enterprise, all while greatly reducing PACER spend.

Our comprehensive service means we can handle Federal, State, and Administrative courts across the country.

Advanced Docket Research



With over 230 million records, Docket Alarm's cloud-native docket research platform finds what other services can't. Coverage includes Federal, State, plus PTAB, TTAB, ITC and NLRB decisions, all in one place.

Identify arguments that have been successful in the past with full text, pinpoint searching. Link to case law cited within any court document via Fastcase.

Analytics At Your Fingertips



Learn what happened the last time a particular judge, opposing counsel or company faced cases similar to yours.

Advanced out-of-the-box PTAB and TTAB analytics are always at your fingertips.

API

Docket Alarm offers a powerful API (application programming interface) to developers that want to integrate case filings into their apps.

LAW FIRMS

Build custom dashboards for your attorneys and clients with live data direct from the court.

Automate many repetitive legal tasks like conflict checks, document management, and marketing.

FINANCIAL INSTITUTIONS

Litigation and bankruptcy checks for companies and debtors.

E-DISCOVERY AND LEGAL VENDORS

Sync your system to PACER to automate legal marketing.