



US005956323A

United States Patent [19]

[11] **Patent Number:** 5,956,323

Bowie

[45] **Date of Patent:** Sep. 21, 1999

[54] **POWER CONSERVATION FOR POTS AND MODULATED DATA TRANSMISSION**

[75] Inventor: **Bruce H. Bowie**, Santa Rose, Calif.

[73] Assignee: **Nokia High Speed Access Products Inc.**, Petaluma, Calif.

[21] Appl. No.: **08/903,504**

[22] Filed: **Jul. 30, 1997**

[51] **Int. Cl.**⁶ **H04M 11/00; H04Q 1/00**

[52] **U.S. Cl.** **370/241; 379/413**

[58] **Field of Search** 370/216, 241, 370/242, 244, 249, 250, 251, 204, 205, 212, 213; 379/1, 2, 5, 9, 15, 23, 26, 27, 32, 93.06, 399, 412, 413, 377

[56] **References Cited**

U.S. PATENT DOCUMENTS

4,484,028	11/1984	Kelley et al.	379/93.14
4,979,208	12/1990	Pruden et al.	379/145
5,483,574	1/1996	Yuyama	379/32
5,590,396	12/1996	Henry	455/426
5,742,527	4/1998	Rybicki et al.	364/705.05
5,799,064	8/1998	Sridhar et al.	375/222

Primary Examiner—Chi H. Pham
Assistant Examiner—Kwang B. Yao
Attorney, Agent, or Firm—Fish & Richardson P.C.

[57] **ABSTRACT**

Methods and apparatus for conserving power in terminal units that transmit and receive modulated data over a communications loop that is shared with voiceband telephone equipment are disclosed. The methods include monitoring the loop to detect a shut-down condition and reducing power consumption of certain of the electronic circuits in the terminal unit upon detection of a shut-down condition. The methods also include monitoring the loop with a monitoring circuit to detect a resume signal outside the voiceband frequency range on the loop and restoring power to the electronic circuits when the resume signal is detected. The apparatuses include a modulated data transmitting and receiving unit having a connector for coupling the unit to a communications loop, circuitry to transmit and receive a modulated data signal in a frequency range above voiceband, and circuitry to detect a resume signal in the frequency range above voiceband and then to initiate a power up sequence for the transmit and receive circuitry.

27 Claims, 3 Drawing Sheets

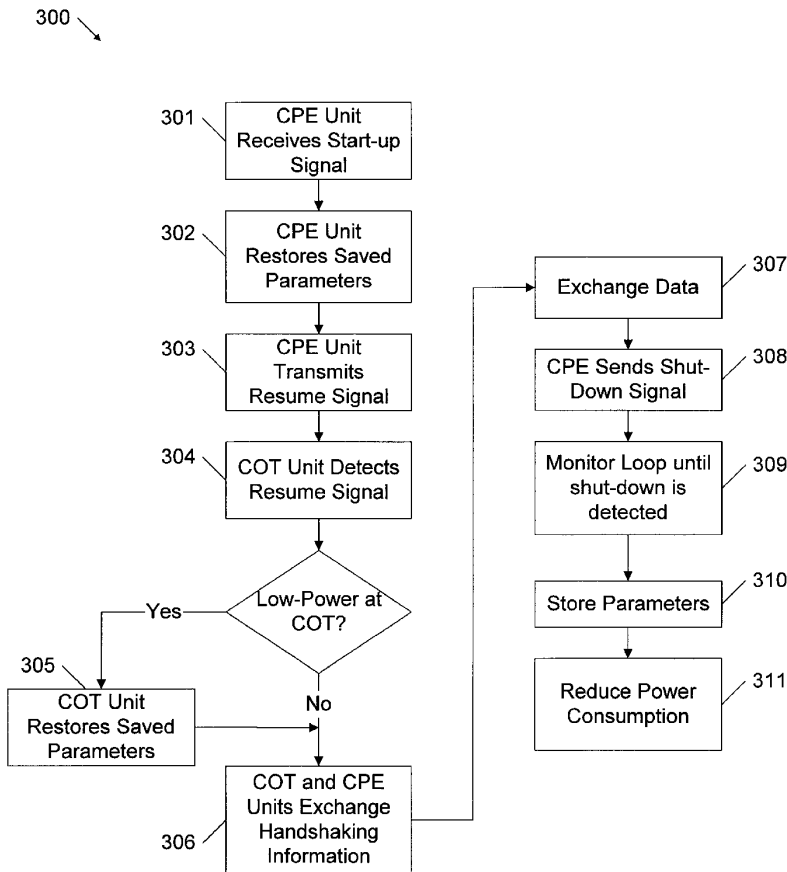

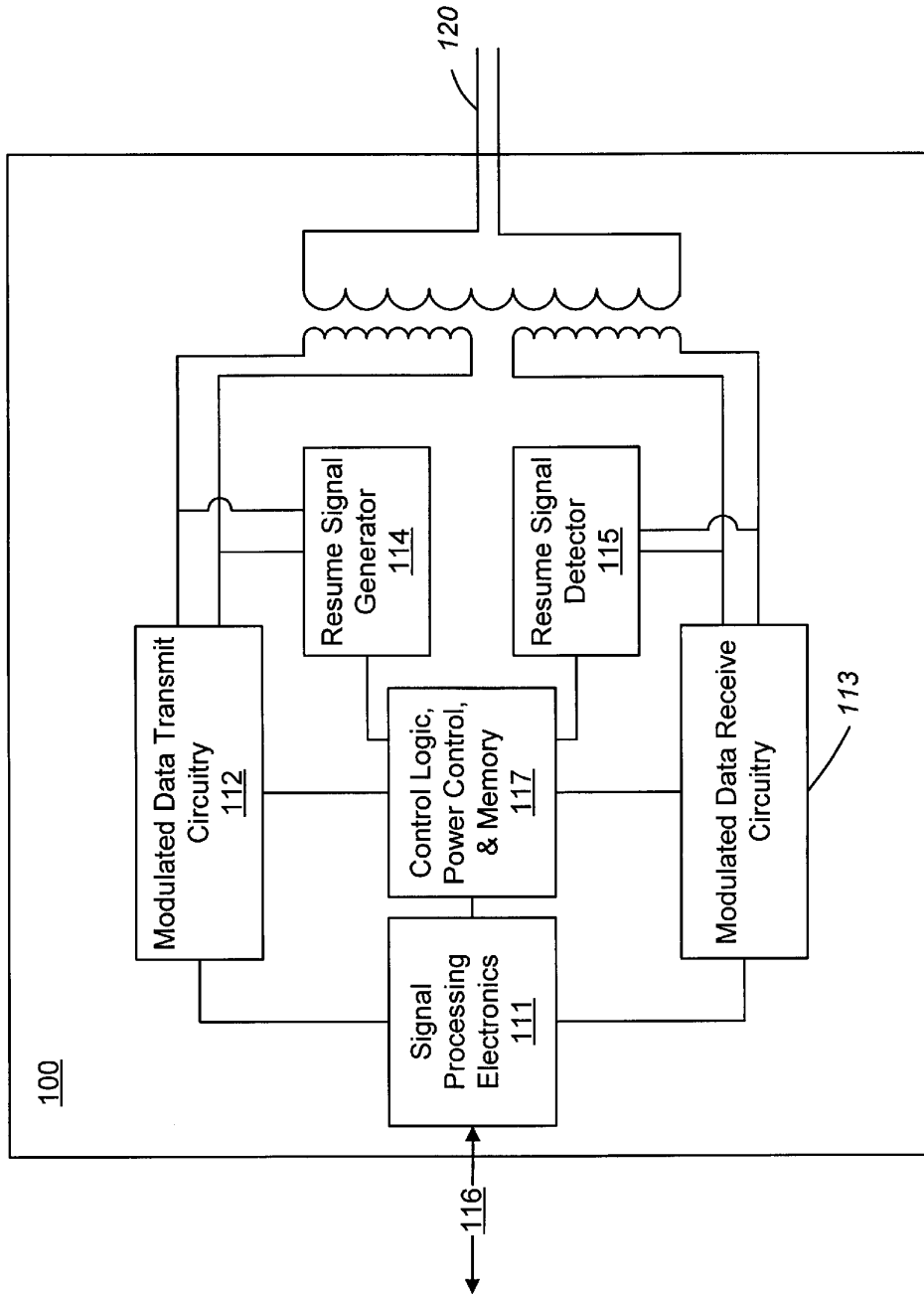

FIG. 1

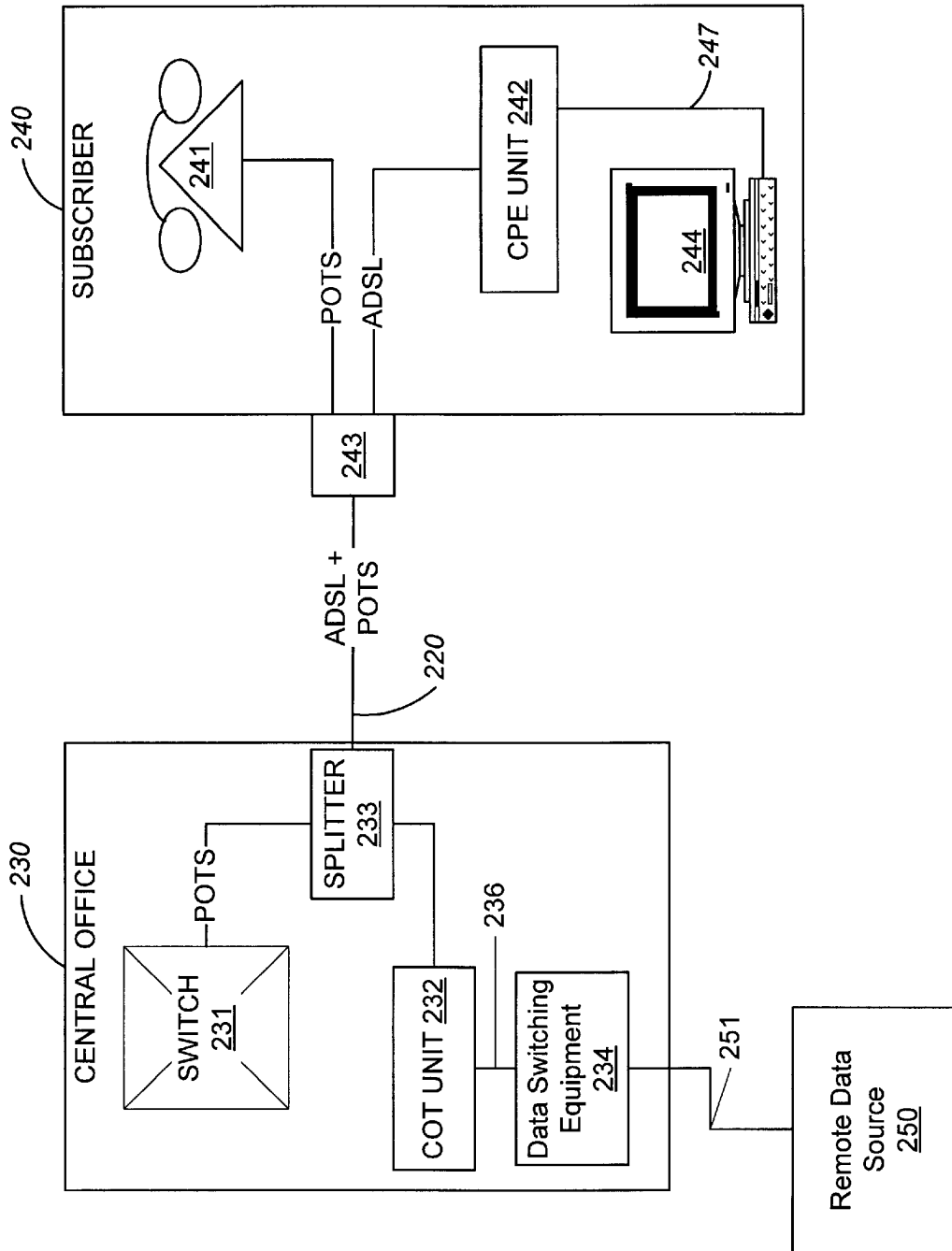

FIG. 2

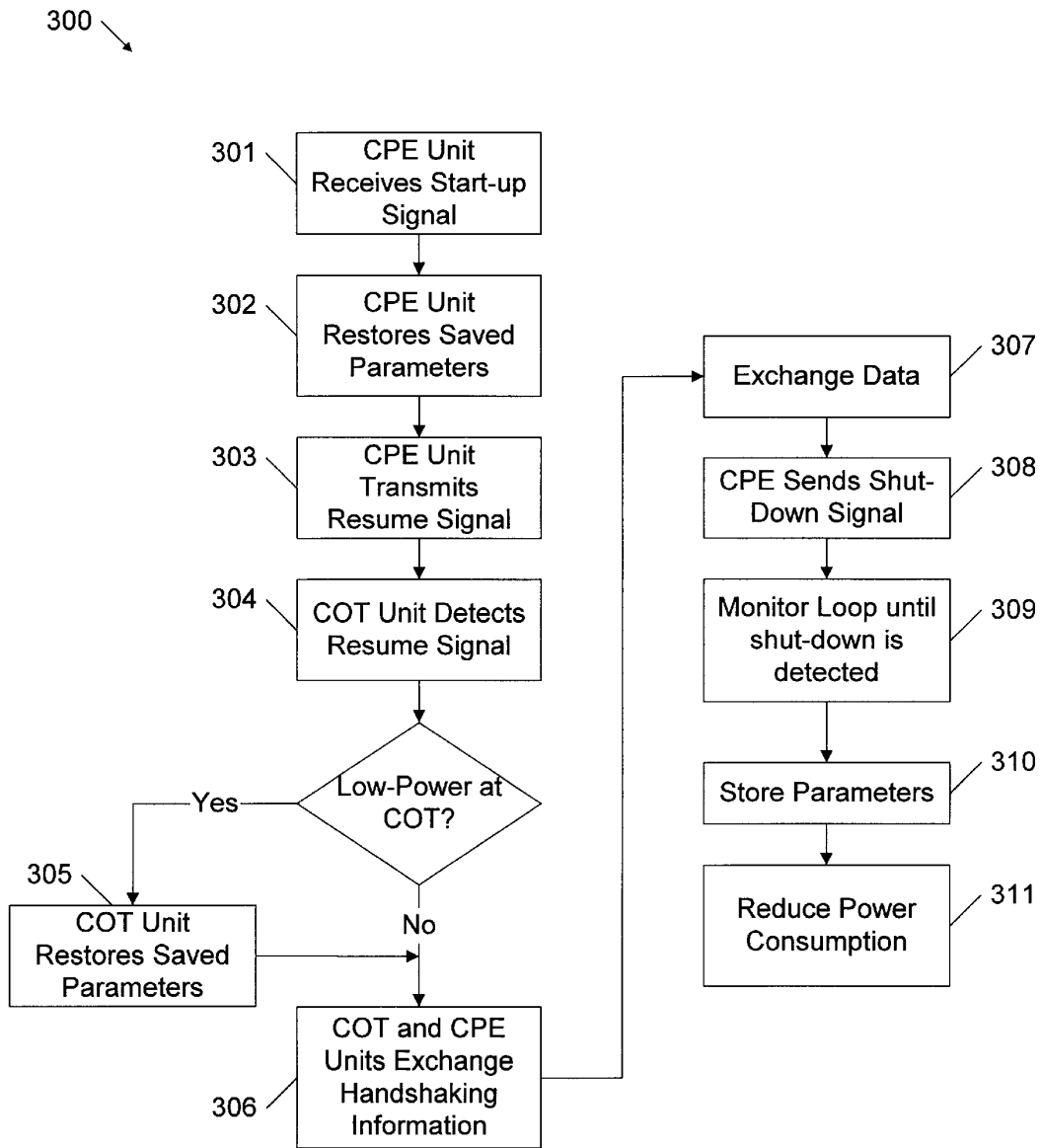

FIG. 3

POWER CONSERVATION FOR POTS AND MODULATED DATA TRANSMISSION

The present invention is directed to a power conservation system for modulated data communications, and more particularly to a power conservation system for transmission systems in which data is modulated over a communications loop from a central office location to a customer premises.

BACKGROUND

Wire loops extending from a telephone company central office to a customer premises are a ubiquitous part of the existing communications infrastructure. These wire loops form a communications network often referred to as the plain old telephone service' (POTS) network. The POTS network originated to support analog voice phone service.

The POTS network currently supports a wide range of communications services in addition to analog voice phone calls. These services include digital data transmissions from facsimile (FAX) machines and computer modems. Voice calls, FAX connections, and computer modem transmissions all operate within the frequency spectrum of traditional POTS calls, thus ensuring compatibility with the existing wire loop infrastructure and allowing transport of these services end-to-end through the POTS phone network. However, the use of POTS-compatible transmission frequencies severely limits the maximum information carrying capacity of the wire loop.

Certain transmission technologies may use carrier frequencies greater than those required for POTS services to exceed the information capacity limits of POTS calls over wire loops. However, since the existing POTS loop infrastructure was not designed for carrying such high frequency signals, severe impediments to such transmission exist. In particular, as a result of electromagnetic coupling among wire loops, electromagnetic noise signals are induced on the loops. This electromagnetic coupling may occur among the large number of loops in the wire bundles that extend from the central office to various customer distribution points.

Noise signals induced on the loops by electromagnetic coupling may not be perceptible on POTS voice calls. However, such signals may significantly interfere with wide-bandwidth modulated data transmissions that use high frequency signals. To reduce interference problems, sophisticated signal processing circuitry, such as digital signal processors (DSPs), are used within modulated data receiver and transmitter units to remove noise, to encode and decode desired signals, and to perform error correction functions.

To minimize the number of wire loops needed to service a customer's premises, POTS signals and modulated data transmission signals may be combined on a single wire loop. To combine POTS and wide-bandwidth modulated data transmission signals, the wide-bandwidth modulated data is transported using frequencies (spectrum) greater than those of POTS services. This spectrum usage allows a POTS service connection to be supported by its traditionally allocated spectrum while simultaneously supporting high frequency modulated data transmission. Thus, current technology permits POTS and high bandwidth data may be carried between customer premise equipment (CPE) and a central office (CO) on a single wire loop. At the central office, the POTS signal frequencies are separated from the high frequency data signal; the POTS signal is then handled by the existing POTS switch and network, while the high frequency spectrum is directed to separate processing components.

Signal processing, transmitting, and receiving circuitry for such high frequency modulated data signals requires a substantial amounts of power, typically up to 5 watts per loop served. For a large central office, potentially serving many thousands of such data connections, this power usage is substantial.

SUMMARY

In general, in one aspect, the invention features a method of conserving power in a terminal unit having a transmitter and receiver for modulated data communication over a communications loop that is shared with voiceband telephone equipment. The method includes monitoring the loop to detect a shut-down condition, reducing power consumption of certain of the electronic circuits in the terminal unit upon detection of a shut-down condition, monitoring the loop with a monitoring circuit to detect a resume signal outside the voiceband frequency range on the loop, and restoring power to the electronic circuits when the resume signal is detected.

Implementations of the invention may include one or more of the following features. The modulated data may be a bit stream including framing information, and a shut-down condition may be indicated by a loss of framing information. The modulated data may include a signaling channel and a shut down condition may be indicated by bits transmitted in the signaling channel. The resume signal may be an AC signal at a frequency above voiceband, such as a 16 kHz AC signal.

In general, in another aspect, the invention features a modulated data transmitting and receiving unit. The unit includes a connector for coupling the unit to a communications loop, circuitry to transmit and receive a modulated data signal in a frequency range above voiceband, and circuitry to detect a resume signal in the frequency range above voiceband and then to initiate a power up sequence for the transmit and receive circuitry.

Implementations of the invention may include one or more of the following features. The connector may be a two-wire connector. The transmit and receive circuitry may include Asymmetric Digital Subscriber Line transmit and receive circuitry. The resume signal detection circuitry may be a 16 kHz frequency detector. The communications loop may be a wireless communications loop. The resume signal may be an AC signal greater than 4 kHz or may be a multi-tone AC signal. The unit may also include a control signal interface to receive a start-up signal, and circuitry to transmit a resume signal upon receipt of the start-up signal.

In general, in another aspect, the invention features a modulated data transmitting and receiving unit. The unit includes a connector for coupling the unit to a communications loop, a control signal interface for receiving a start-up signal, circuitry to transmit and receive a modulated data signal at frequencies above voiceband, and circuitry to transmit a resume signal on the loop upon receipt of a start-up signal on the control signal interface.

Implementations of the invention may include one or more of the following features. The communications loop may a wireless loop. The control signal interface may be a data interface, such as a peripheral component interconnect (PCI) interface. The start-up signal may be indicated by receipt of data on the control signal interface. The control signal interface may be used for the exchange of both the start-up signal and of data between the modulated data transmitting and receiving unit and customer premise equipment.

Explore Litigation Insights

Docket Alarm provides insights to develop a more informed litigation strategy and the peace of mind of knowing you're on top of things.

Real-Time Litigation Alerts



Keep your litigation team up-to-date with **real-time alerts** and advanced team management tools built for the enterprise, all while greatly reducing PACER spend.

Our comprehensive service means we can handle Federal, State, and Administrative courts across the country.

Advanced Docket Research



With over 230 million records, Docket Alarm's cloud-native docket research platform finds what other services can't. Coverage includes Federal, State, plus PTAB, TTAB, ITC and NLRB decisions, all in one place.

Identify arguments that have been successful in the past with full text, pinpoint searching. Link to case law cited within any court document via Fastcase.

Analytics At Your Fingertips



Learn what happened the last time a particular judge, opposing counsel or company faced cases similar to yours.

Advanced out-of-the-box PTAB and TTAB analytics are always at your fingertips.

API

Docket Alarm offers a powerful API (application programming interface) to developers that want to integrate case filings into their apps.

LAW FIRMS

Build custom dashboards for your attorneys and clients with live data direct from the court.

Automate many repetitive legal tasks like conflict checks, document management, and marketing.

FINANCIAL INSTITUTIONS

Litigation and bankruptcy checks for companies and debtors.

E-DISCOVERY AND LEGAL VENDORS

Sync your system to PACER to automate legal marketing.