



US005089927A

United States Patent [19]

[11] Patent Number: **5,089,927**

Bulan et al.

[45] Date of Patent: **Feb. 18, 1992**

- [54] **POWER FEED CIRCUIT FOR DIGITAL COMMUNICATIONS TERMINAL EQUIPMENT**
- [75] Inventors: **Sergiu Bulan, Willowdale; Johannes L. Holt, Brampton, both of Canada**
- [73] Assignee: **Northern Telecom Limited, Montreal, Canada**
- [21] Appl. No.: **420,487**
- [22] Filed: **Oct. 12, 1989**
- [51] Int. Cl.⁵ **H02H 3/08**
- [52] U.S. Cl. **361/87**
- [58] Field of Search **361/87, 93, 100, 78, 361/66, 111; 379/2, 32, 93, 94, 412**

Attorney, Agent, or Firm—J. E. Moorhouse

[57] ABSTRACT

Integrated Services Digital Network (ISDN) terminal equipments (TEs) are remotely powered from a central source via line interface circuits. One function of the line interface circuit is that of conducting energizing direct current for the associated telecommunications terminal equipment while providing effective overcurrent protection in spite of widely variable load current requirements which occasionally may mimic a faulty over current condition. The line interface circuit includes first and second power terminals for connection to a source of power, first and second line terminals for supplying said energizing direct current, and a current control means, being connected between a one of the first and second power terminals and a respective one of the first and second line terminals, for temporarily switching off an inrush current in excess of a dynamic limit, and permanently switching off a load current in excess of a static limit until a virtual open circuit condition occurs across the first and second line terminals.

[56] References Cited

U.S. PATENT DOCUMENTS

- 3,858,089 12/1974 Poindexter 361/120 X
- 4,983,955 1/1991 Ham, Jr. et al. 361/93
- 4,987,512 1/1991 Mulshine 361/93

Primary Examiner—Steven L. Stephan
 Assistant Examiner—E. To

4 Claims, 3 Drawing Sheets

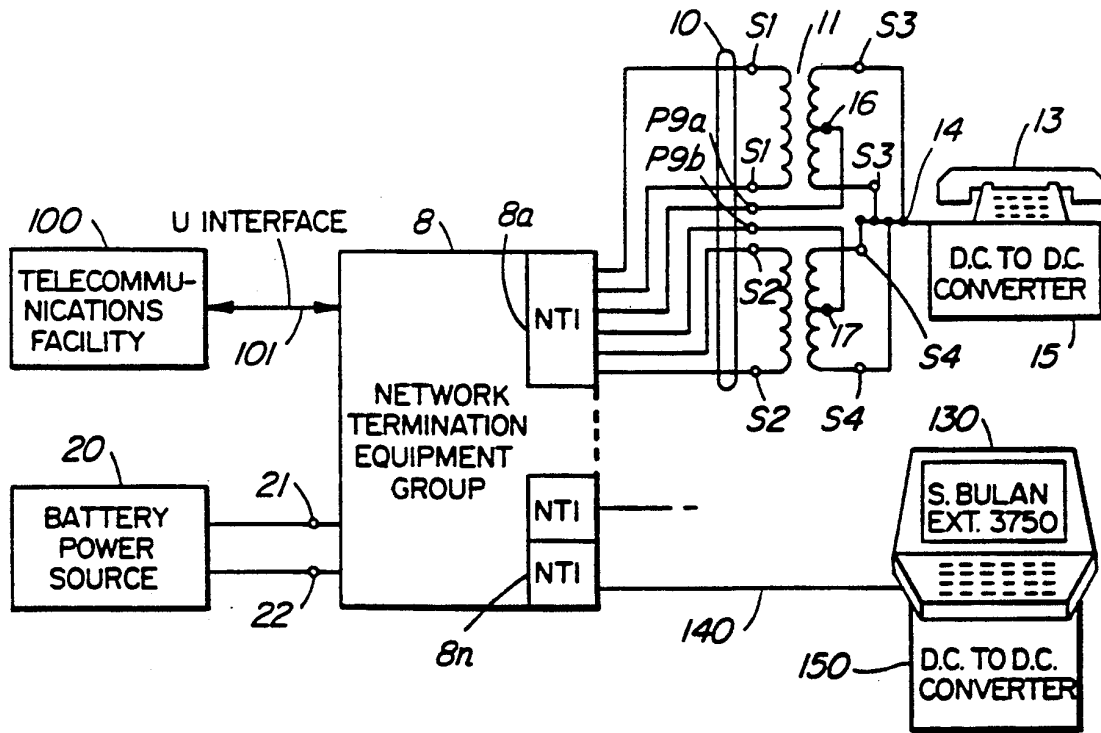

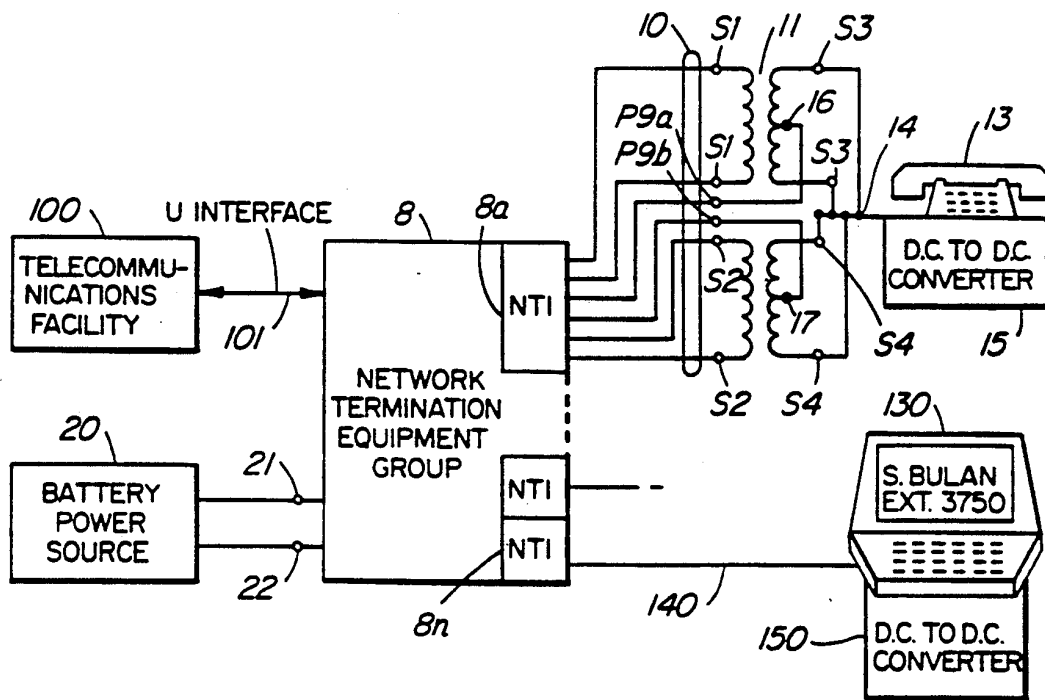

FIG. 1

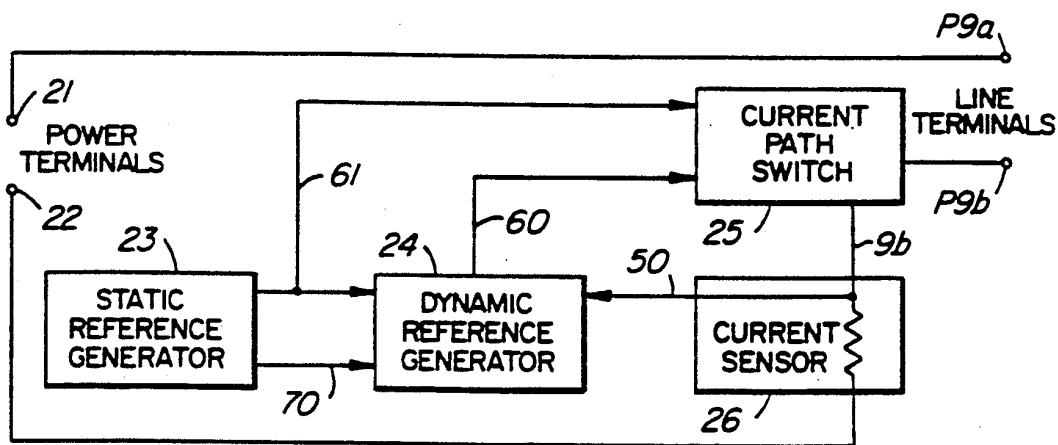

FIG. 2

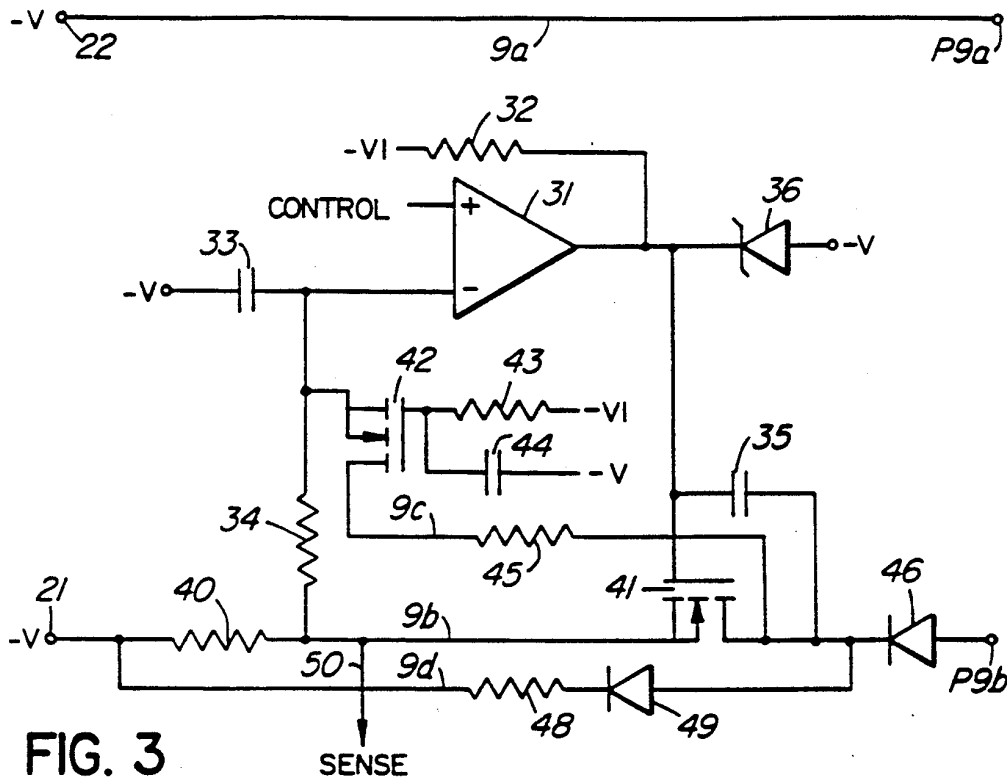

FIG. 3

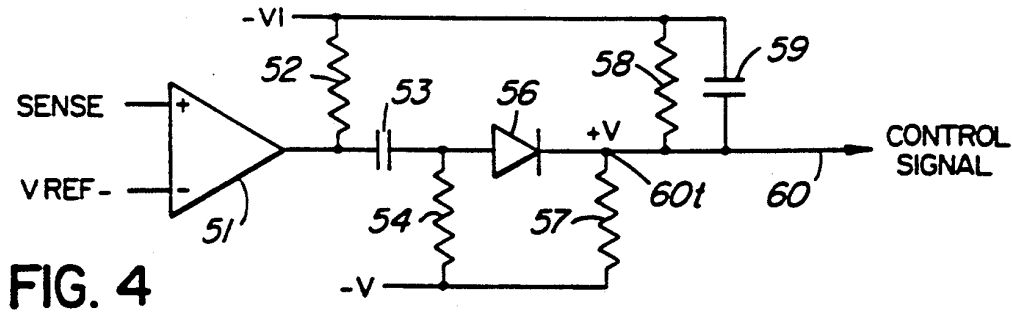

FIG. 4

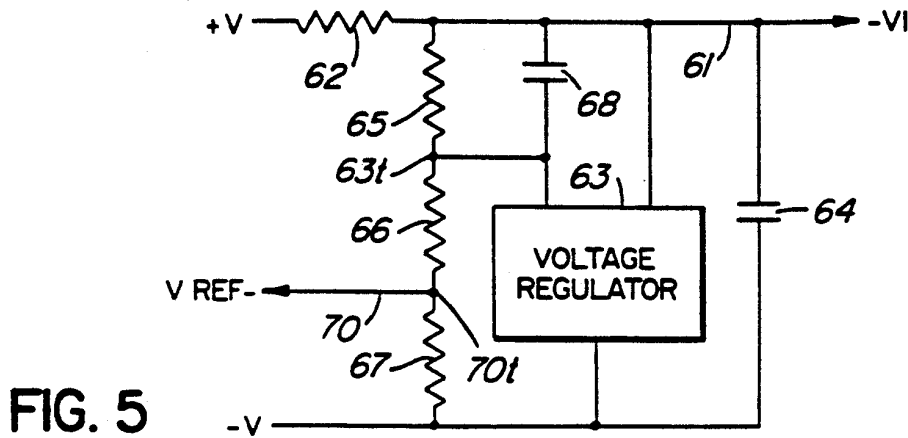

FIG. 5

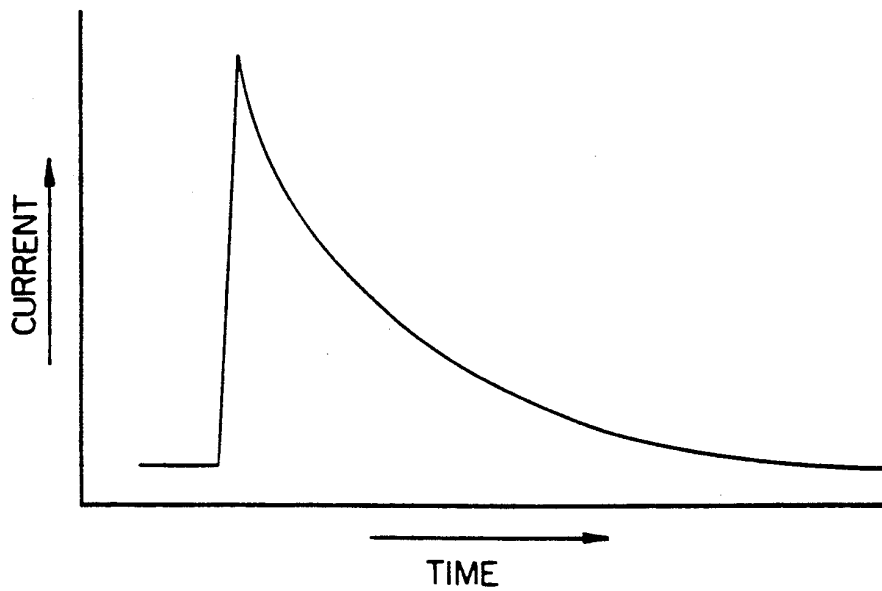

FIG. 6

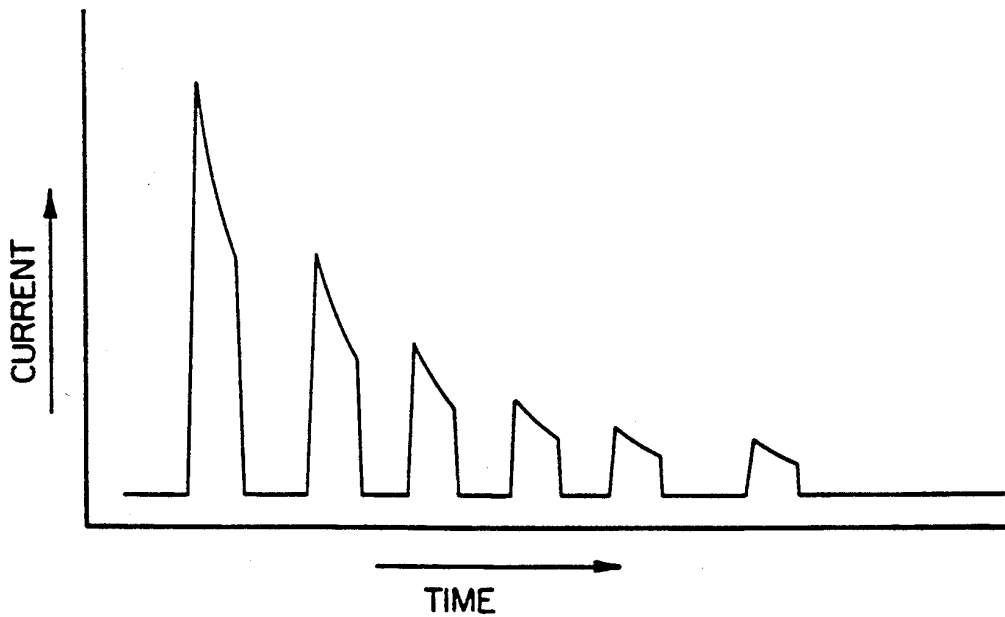

FIG. 7

POWER FEED CIRCUIT FOR DIGITAL COMMUNICATIONS TERMINAL EQUIPMENT

FIELD OF THE INVENTION

The invention is in the field of power feed apparatus and methods for supplying transmission line connected terminals with energizing current. More particularly the invention relates to apparatus and methods for powering a digital signal telecommunications terminal equipment wherein an initial power-up current in-rush may exceed a normal load current by many times.

BACKGROUND OF THE INVENTION

Traditionally a telephone terminal apparatus, for example telephones and the like, is coupled through an associated telephone line with a central power source via a line interface circuit. The line interface circuit includes circuitry, usually of a resistive nature, for feeding energizing direct current from the central power source to the telephone terminal apparatus. Recently, various active line interface circuits have been developed wherein the function of feeding the energizing direct current is performed by active elements which may optimize the coupling of the telephone with an associated telephone system. Such active line circuits may include over current protection circuitry which responds to unintended operational faults, for example power line crosses, short circuits or ground faults, by somewhat limiting current flow in the interest of preventing catastrophic failure of line interface circuit.

Recently telephone terminal apparatus of a digital nature have been developed to take advantage of the recommended Integrated Services Digital Network (ISDN) standard. In ISDN jargon a terminal apparatus is usually referred to as a terminal equipment (TE), a line interface circuit as a network termination (NT1), and a line for connection between a NT1 and a TE as a terminal (T) interface, hereafter referred to as a T bus. The TEs are characterized by digital circuitry requiring an operating voltage or voltages not conventionally available from an associated telephone facility. However the traditional reliability of telephony service is never the less preferred. Hence one arrangement is provided wherein a convenient physical location for a group of NT1s is also provided with a line power source, which is intended to be more reliable than the supply service expected from a local electrical utility. Each of the NT1s is provided with power from the line power source, at a potential of about 50 volts, so that energizing direct current is made available to each associated TE via the wires of the interconnecting T bus. A typical TE includes a direct current to direct current (DC to DC converter which utilizes between about 40 to 60 milliamperes of current from the T bus to provide the required voltage or voltages for normal operation. However initiation of operation of a TE, such as when it is first plugged into a T bus or when power is initially applied at the NT1, typically draws a momentary surge of current. The surge of current is that which is required to initiate operation of the typical DC to DC converter and associated filter capacitors. In a normal power up event in a TE, the DC to DC converter usually draws a current peak or current inrush, which may exceed an ampere for as much as ten milliseconds. In such circumstances the typical current limiting circuit intended to protect the typical line interface circuit is inappropriate for operation throughout the whole cur-

rent load regime. For example, if a current limit of twice the normal operating current is set, there will be insufficient current for start up of the DC to DC converter and on the other hand if a current limit sufficiently great to accommodate start up is set, a fault may be permitted to draw current for a period of time sufficient to seriously jeopardize the operations of the NT1 physically adjacent, and the line power source circuits.

It is an object of the invention to supply operating current from a central line power source via a line interface circuit, to a terminal equipment having a DC to DC converter, while providing an over current protection feature which is effective across the entire load current regime of the terminal equipment.

SUMMARY OF THE INVENTION

In accordance with the invention, a current control apparatus is provided for supplying an energizing direct current flow from a source of power via a transmission line to a telecommunications terminal apparatus being continuously operable while drawing a load current which is exceeded by an inrush current being greater than the load current at a moment of power up. The current control apparatus is for connection in series between the power source and the transmission line and comprises: means for generating a magnitude signal being representative of an amount of said energizing direct current flow; means for generating a static control signal for defining a maximum limit of load current; means for generating a momentary dynamic control signal for defining a maximum limit of the inrush current in response to the magnitude signal increasing from a level representative of less than the maximum limit of load current to a level representative of more than the maximum limit of load current; and switch means responsive to the magnitude signal and the static and dynamic control signals, to be set in an ON condition for conducting said current flow, when either one of said maximum limits is greater than the energizing direct current as is instantly represented by the magnitude signal, otherwise to be reset in an OFF condition, and while in the OFF condition being responsive to an apparent open circuit condition of the transmission line to become set in the ON condition.

In one example, a line interface circuit couples energizing direct current, from a line power supply to a communications line, for operation of a telecommunications terminal apparatus. The line interface circuit comprises: first and second power terminals for connection to the line power supply; first and second line terminals for connection to the communication line; and a current control means, being connected between a one of the first and second power terminals and a respective one of the first and second line terminals, for conducting the energizing direct current there between, for temporarily isolating the power terminal from the line terminal to stop an inrush current in excess of a dynamic limit, and permanently isolating the power terminal from the line terminal to stop a load current in excess of a static limit, until a virtual open circuit condition occurs across the first and second line terminals.

Also in accordance with the invention a method is provided for supplying an energizing direct current flow, from a source of power via a transmission line to a telecommunications terminal apparatus, said terminal apparatus being continuously operable while drawing a load current which is exceeded by an inrush current

Explore Litigation Insights

Docket Alarm provides insights to develop a more informed litigation strategy and the peace of mind of knowing you're on top of things.

Real-Time Litigation Alerts



Keep your litigation team up-to-date with **real-time alerts** and advanced team management tools built for the enterprise, all while greatly reducing PACER spend.

Our comprehensive service means we can handle Federal, State, and Administrative courts across the country.

Advanced Docket Research



With over 230 million records, Docket Alarm's cloud-native docket research platform finds what other services can't. Coverage includes Federal, State, plus PTAB, TTAB, ITC and NLRB decisions, all in one place.

Identify arguments that have been successful in the past with full text, pinpoint searching. Link to case law cited within any court document via Fastcase.

Analytics At Your Fingertips



Learn what happened the last time a particular judge, opposing counsel or company faced cases similar to yours.

Advanced out-of-the-box PTAB and TTAB analytics are always at your fingertips.

API

Docket Alarm offers a powerful API (application programming interface) to developers that want to integrate case filings into their apps.

LAW FIRMS

Build custom dashboards for your attorneys and clients with live data direct from the court.

Automate many repetitive legal tasks like conflict checks, document management, and marketing.

FINANCIAL INSTITUTIONS

Litigation and bankruptcy checks for companies and debtors.

E-DISCOVERY AND LEGAL VENDORS

Sync your system to PACER to automate legal marketing.