

LXT914

Flexible Quad Ethernet Repeater

General Description

The LXT914 is an integrated multi-port repeater designed for mixed-media networks. It provides all the active circuitry required for the repeater function in a single CMOS device. It includes one Attachment Unit Interface (AUI) port and four 10BASE-T transceivers. The AUI port is mode selectable: DTE mode allows connection of an external transceiver (10BASE2, 10BASE5, 10BASE-T or FOIRL) or a drop cable. MAU mode creates a MAU output allowing direct connection to another DTE interface. The 10BASE-T transceivers are entirely self-contained with internal filters which simplify the design work required for FCC-compliant EMI performance.

An inter-repeater backplane interface allows 128 or more 10BASE-T ports to be cascaded together. In addition, a serial port provides information for network management.

The LXT914 requires only a single 5-volt power supply due to an advanced CMOS fabrication process.

Applications

- LAN Repeaters
- Integrated Repeaters
- Switched Repeater Clusters

Features

- Four integrated 10BASE-T transceivers and one AUI transceiver on a single chip
- Programmable DTE/MAU interface on AUI port
- Seven integrated LED drivers with four unique operational modes
- On-chip transmit and receive filtering
- Automatic partitioning of faulty ports, enabled on an individual port basis
- Automatic polarity detection and correction
- Programmable squelch level allows extended range in low-noise environments
- Synchronous or asynchronous inter-repeater backplane supports "hot swapping"
- Inter-repeater backplane allows cascaded repeaters, linking 128 or more 10BASE-T ports
- Serial port for selecting programmable options
- 68-pin PLCC (Commercial or Extended temp range)
- 100-pin PQFP (Commercial temp range)

LXT914 Block Diagram

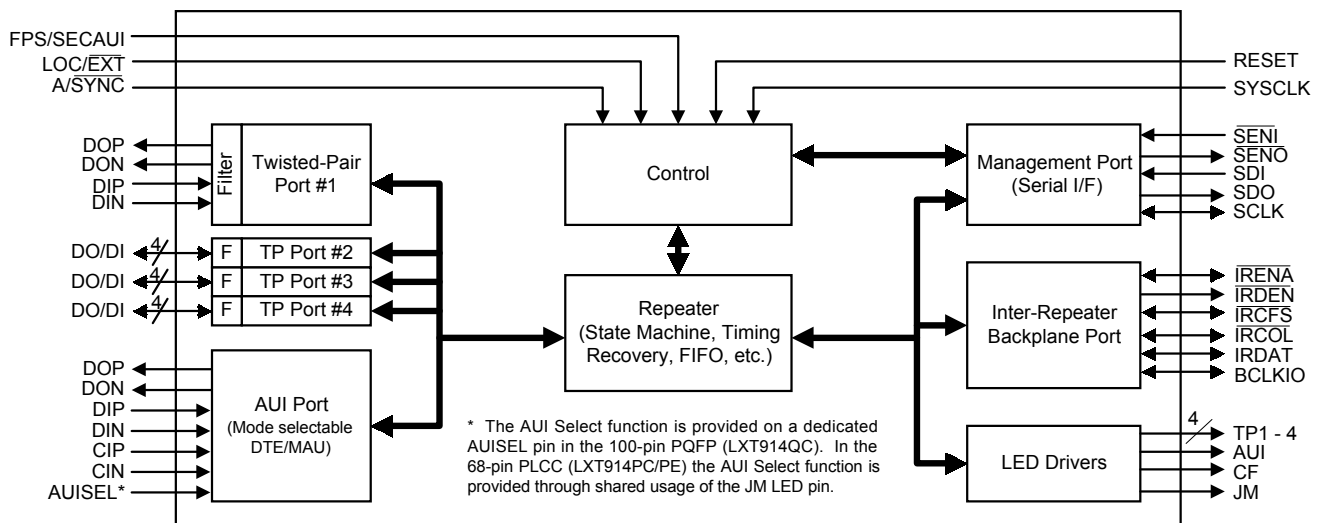
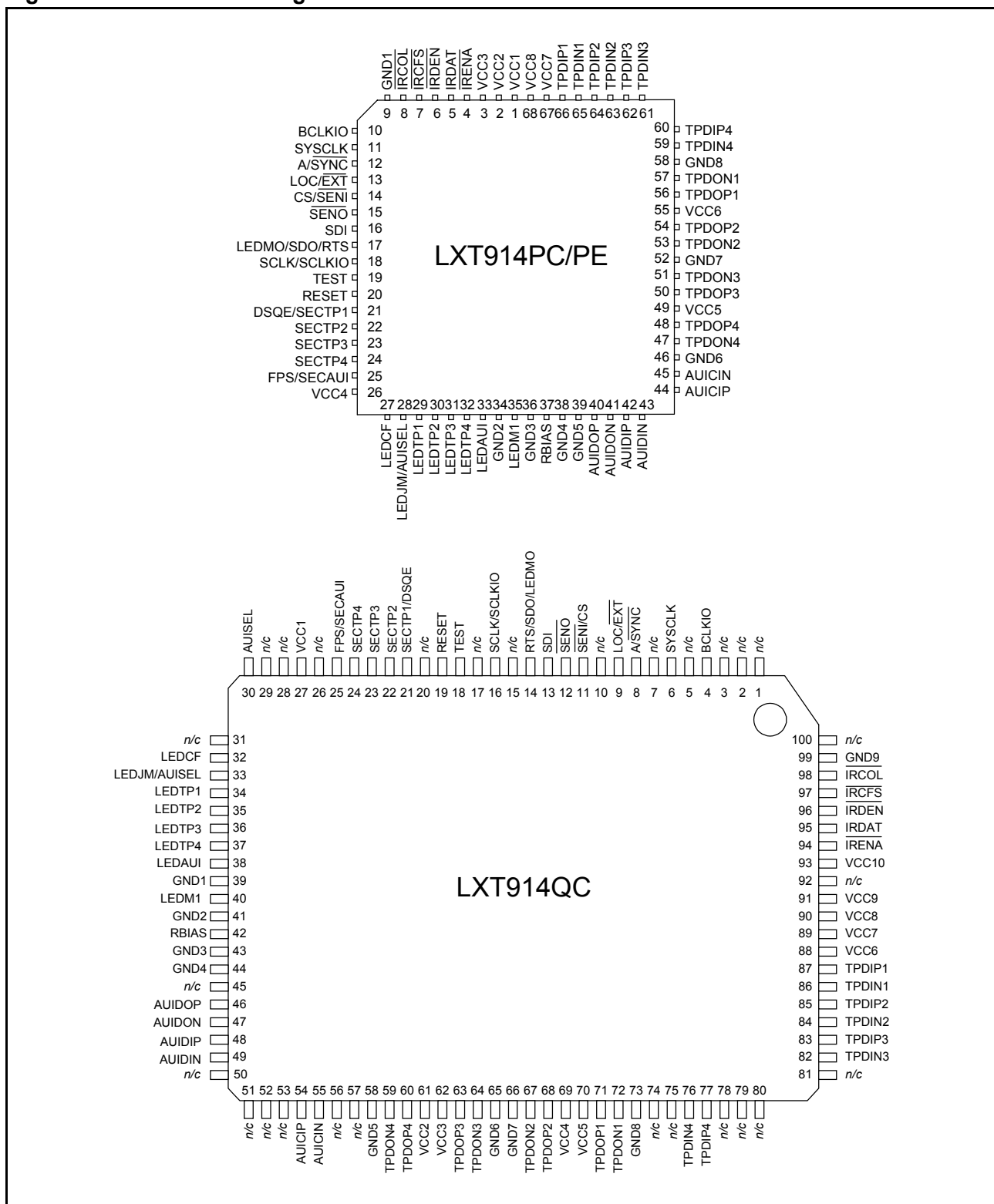

TABLE OF CONTENTS

PIN ASSIGNMENTS AND SIGNAL DESCRIPTIONS	12-3
FUNCTIONAL DESCRIPTION	12-5
Introduction	12-9
External Interfaces	12-9
10BASE-T Ports	12-9
AUI Port	12-9
Serial Port	12-9
Inter-Repeater Backplane	12-9
Internal Repeater Circuitry	12-10
Initialization	12-10
Local Management Mode Initialization	12-10
External Management Mode Initialization	12-14
10BASE-T Port Operation	12-15
10BASE-T Reception	12-15
10BASE-T Transmission	12-15
10BASE-T Link Integrity Testing	12-15
AUI Port Operation	12-15
AUI Reception	12-15
AUI Transmission	12-15
AUI Mode Selection (DTE/MAU)	12-16
Collision Handling	12-16
Security Mode	12-16
LED Display	12-16
APPLICATION INFORMATION	12-19
12-Port Hub Repeater Schematic	12-20
8-Port Print or File Server Schematic	12-24
TEST SPECIFICATIONS	12-26
Absolute Maximum Ratings	12-26
Recommended Operating Conditions	12-26
I/O Electrical Characteristics	12-26
AUI Electrical Characteristics	12-27
Twisted-Pair Electrical Characteristics	12-27
IRB Electrical Characteristics	12-27
Switching Characteristics	12-28
Serial Port Timing	12-28
Inter-Repeater Bus Timing	12-29

LXT914 PIN ASSIGNMENTS AND SIGNAL DESCRIPTIONS

Figure 1: LXT914 Pin Assignments



LXT914 Flexible Quad Ethernet Repeater

Table 1: LXT914 Power, Ground and Clock Signal Descriptions

Pin #		Symbol	I/O	Description
PLCC	PQFP			
1	27	VCC1	—	Power Supply Inputs. These pins each require a +5 VDC power supply. The various pins may be supplied from a single power source, but special de-coupling requirements may apply. Each VCC input must be within ± 0.3 V of every other VCC input.
2	61	VCC2	—	
3	62	VCC3	—	
26	69	VCC4	—	
49	70	VCC5	—	
55	88	VCC6	—	
67	89	VCC7	—	
68	90	VCC8	—	
—	91	VCC9	—	
—	93	VCC10	—	
9	39	GND1	—	Ground. These pins provide ground return paths for the various power supply pins.
34	41	GND2	—	
36	43	GND3	—	
38	44	GND4	—	
39	58	GND5	—	
46	65	GND6	—	
52	66	GND7	—	
58	73	GND8	—	
—	99	GND9	—	
37	42	RBIAS	—	Bias. This pin provides bias current for the internal circuitry. The 100 μ A bias current is provided through an external 12.4 k Ω resistor to ground.
10	4	BCLKIO	I/O	Backplane Clock. This 10 MHz clock synchronizes multiple repeaters on a common backplane. In the synchronous mode, BCLKIO must be supplied to all repeaters from a common external source. In the asynchronous mode, BCLKIO is supplied only when a repeater is outputting data to the bus. Each repeater outputs its internally recovered clock when it takes control of the bus. Other repeaters on the backplane then sync to BCLKIO for the duration of the transmission.
11	6	SYCLK	I	System Clock. The required 20 MHz system clock is input at this pin. Clock must have a 40-60 duty cycle with < 10 ns rise time.

LXT914 Pin Assignments and Signal Descriptions

Table 2: LXT914 Inter-Repeater Backplane Signal Descriptions

PLCC	PQFP	Symbol	I/O	Description
4	94	IRENA	I/O	Inter-Repeater Backplane Enable. This pin allows individual LXT914 repeaters to take control of the Inter-Repeater Backplane (IRB) data bus (IRDAT). The $\overline{\text{IRENA}}$ bus must be pulled up locally by a 330 Ω resistor. ¹
5	95	IRDAT	I/O	IRB Data. This pin is used to pass data between multiple repeaters on the IRB. The IRDAT bus must be pulled up locally by a 330 Ω resistor. ¹
6	96	IRDEN	O	IRB Driver Enable. The $\overline{\text{IRDEN}}$ pin is used to enable external bus drivers which may be required in synchronous systems with large backplanes. This is an active Low signal, maintained for the duration of the data transmission. $\overline{\text{IRDEN}}$ must be pulled up locally by a 330 Ω resistor.
7 8	97 98	$\overline{\text{IRCFS}}$ $\overline{\text{IRCOL}}$	I/O I/O	IRB Collision Flag Sense ($\overline{\text{IRCFS}}$) and IRB Collision ($\overline{\text{IRCOL}}$). These two pins are used for collision signalling between multiple LXT914 devices on the Inter-Repeater Backplane (IRB). Both the $\overline{\text{IRCFS}}$ bus and the $\overline{\text{IRCOL}}$ bus must be pulled up globally with 330 Ω resistors. ($\overline{\text{IRCFS}}$ requires a precision resistor [$\pm 1\%$].) ²

1. $\overline{\text{IRENA}}$ and IRDAT can be buffered between boards in multi-board configurations. Where buffering is used, a 330 Ω pull-up resistor can be used on each signal, on each board. Where no buffering is used, the total impedance should be no less than 330 Ω .

2. $\overline{\text{IRCFS}}$ and $\overline{\text{IRCOL}}$ cannot be buffered. In multi-board configurations, the total impedance on $\overline{\text{IRCOL}}$ should be no smaller than 330 Ω . $\overline{\text{IRCFS}}$ should be pulled up only once, by a single 330 Ω , 1% resistor.

Table 3: LXT914 Mode Select and Control Signal Descriptions

PLCC	PQFP	Symbol	I/O	Description
12	8	A/SYNC	I	Backplane Sync Mode Select. This pin selects the backplane sync mode. When this pin is left floating an internal pull-up defaults to the Asynchronous mode (A/SYNC High). In the asynchronous mode 12 or more LXT914s can be connected on the backplane, and an external 10 MHz backplane clock source is not required. When the synchronous mode is selected (A/SYNC tied Low), 32 or more LXT914s can be connected to the backplane and an external 10 MHz backplane clock source is required.
13	9	LOC/ $\overline{\text{EXT}}$	I	Management Mode Select. This pin selects the management mode. When this pin is left floating, an internal pull-up defaults to the Local management mode (LOC/ $\overline{\text{EXT}}$ High). In the Local mode, setup parameters are downloaded from an EEPROM during initialization. Once initialized with the setup parameters, the repeater functions independently.
28	33	LEDJM/ AUISEL	I/O	LED Driver or DTE/MAU Select. At reset, this pin selects the mode of the AUI port. If left floating, an internal pull-down device forces the AUI port to DTE mode. If pulled High with an external resistor, the port changes to a MAU, in which case the functions of the LEDJM pin are disabled and the default LED mode (Refer to Table 7) is not available.
—	30	AUISEL	I	DTE/MAU Select. This pin changes the mode of the AUI port independent of the condition at reset. This function is available only in the 100-pin PQFP package.
17 35	14 40	LEDM0 LEDM1	I/O I/O	LED Mode 0 & 1 Select. These two pins select one of four possible LED modes of operation. The Functional Description section describes the four modes.

Explore Litigation Insights

Docket Alarm provides insights to develop a more informed litigation strategy and the peace of mind of knowing you're on top of things.

Real-Time Litigation Alerts



Keep your litigation team up-to-date with **real-time alerts** and advanced team management tools built for the enterprise, all while greatly reducing PACER spend.

Our comprehensive service means we can handle Federal, State, and Administrative courts across the country.

Advanced Docket Research



With over 230 million records, Docket Alarm's cloud-native docket research platform finds what other services can't. Coverage includes Federal, State, plus PTAB, TTAB, ITC and NLRB decisions, all in one place.

Identify arguments that have been successful in the past with full text, pinpoint searching. Link to case law cited within any court document via Fastcase.

Analytics At Your Fingertips



Learn what happened the last time a particular judge, opposing counsel or company faced cases similar to yours.

Advanced out-of-the-box PTAB and TTAB analytics are always at your fingertips.

API

Docket Alarm offers a powerful API (application programming interface) to developers that want to integrate case filings into their apps.

LAW FIRMS

Build custom dashboards for your attorneys and clients with live data direct from the court.

Automate many repetitive legal tasks like conflict checks, document management, and marketing.

FINANCIAL INSTITUTIONS

Litigation and bankruptcy checks for companies and debtors.

E-DISCOVERY AND LEGAL VENDORS

Sync your system to PACER to automate legal marketing.