



(12) **United States Patent**
Marshall

(10) **Patent No.:** **US 7,061,142 B1**
(45) **Date of Patent:** **Jun. 13, 2006**

- (54) **INLINE POWER DEVICE DETECTION**
- (75) Inventor: **Robert A. Marshall**, Georgetown, TX (US)
- (73) Assignee: **Cisco Technology, Inc.**, San Jose, CA (US)
- (*) Notice: Subject to any disclaimer, the term of this patent is extended or adjusted under 35 U.S.C. 154(b) by 377 days.
- (21) Appl. No.: **10/447,419**
- (22) Filed: **May 28, 2003**
- (51) **Int. Cl.**
H03K 3/00 (2006.01)
- (52) **U.S. Cl.** **307/106; 307/105**
- (58) **Field of Classification Search** **307/105, 307/106**
See application file for complete search history.

5,365,177 A *	11/1994	Hamp et al.	324/547
5,369,680 A *	11/1994	Borbas et al.	379/10.02
5,406,260 A	4/1995	Cummings et al.	340/568
5,541,957 A	7/1996	Lau	375/258
5,574,748 A	11/1996	Vander Mey et al.	375/204
5,655,077 A	8/1997	Jones et al.	395/187.01
5,659,542 A	8/1997	Bell et al.	370/496
5,671,354 A	9/1997	Ito et al.	395/187.01
5,684,950 A	11/1997	Dare et al.	395/187.01
5,796,185 A	8/1998	Takata et al.	307/140
5,799,040 A	8/1998	Lau	375/258
5,802,042 A	9/1998	Natarajan et al.	370/255
5,811,962 A *	9/1998	Ceccherelli et al.	323/282
5,815,665 A	9/1998	Teper et al.	395/200.59
5,918,016 A	6/1999	Brewer et al.	395/200.5

(Continued)

FOREIGN PATENT DOCUMENTS

EP 0 412 422 A2 * 1/1990

(Continued)

OTHER PUBLICATIONS

Kiss, Peter (candidate), "Chapter 3, Cascaded Delta-Sigma ADCs", Thesis; "Politehnica" University of Timisoara; cover page plus pp. 45-71, Dec. 31, 1999.

(Continued)

Primary Examiner—Lynn Feild
Assistant Examiner—Michael Rutland-Wallis
(74) *Attorney, Agent, or Firm*—Baker Botts L.L.P.

(57) **ABSTRACT**

According to one embodiment of the invention, a method for providing power to a device coupled to a communications switch through a data line is provided. The method includes determining that the device includes a diode. The method also includes providing power to the device in response to the determination.

22 Claims, 3 Drawing Sheets

(56) **References Cited**

U.S. PATENT DOCUMENTS

4,131,767 A	12/1978	Weinstein	179/170.2
4,161,719 A	7/1979	Parikh et al.	340/147 SY
4,232,199 A	11/1980	Boatwright et al.	179/18 B
4,397,020 A	8/1983	Howson	370/105
4,532,626 A	7/1985	Flores et al.	370/85
4,599,494 A	7/1986	Welty	179/84 T
4,626,954 A	12/1986	Damiano et al.	361/96
4,710,949 A	12/1987	Ahuja	379/26
4,723,267 A	2/1988	Jones et al.	379/93
4,733,389 A	3/1988	Puvogel	370/5
4,875,223 A	10/1989	Curtis	375/36
4,969,179 A	11/1990	Kanare et al.	379/33
5,029,201 A	7/1991	Bindels	379/98
5,034,948 A	7/1991	Mizutani et al.	379/79
5,056,131 A	10/1991	Kanare et al.	379/33
RE33,900 E	4/1992	Howson	370/105
5,199,049 A	3/1993	Wilson	375/104
5,223,806 A	6/1993	Curtis et al.	333/12
5,311,518 A	5/1994	Takato et al.	370/110.1
5,321,372 A	6/1994	Smith	333/1

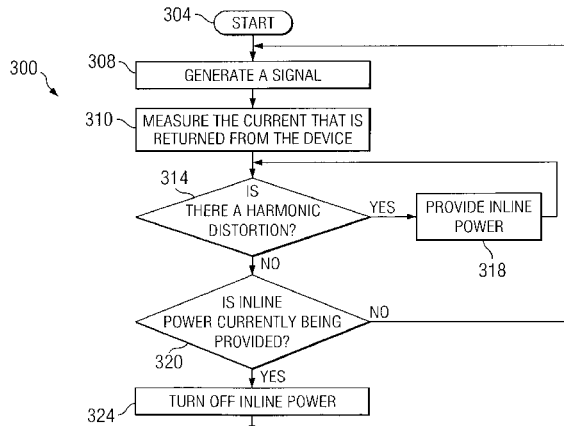

U.S. PATENT DOCUMENTS

5,944,824	A	8/1999	He	713/201
5,947,773	A	9/1999	Karam	439/676
5,994,998	A	11/1999	Fisher et al.	340/310.01
6,011,910	A	1/2000	Chau et al.	395/200.59
6,021,496	A	2/2000	Dutcher et al.	713/202
6,047,376	A	4/2000	Hosoe	713/201
6,092,196	A	7/2000	Reiche	713/200
6,115,468	A	9/2000	De Nicolo	379/413
6,134,666	A	10/2000	De Nicolo	713/300
6,140,911	A	10/2000	Fisher et al.	340/310.01
6,218,930	B1	4/2001	Katzenberg et al.	340/310.01
6,295,356	B1	9/2001	De Nicolo	379/413
6,308,240	B1	10/2001	De Nicolo	710/300
6,310,781	B1	10/2001	Karam	361/764
6,347,949	B1	2/2002	Edwards et al.	439/170
6,459,275	B1*	10/2002	Ewalt et al.	324/539
6,535,983	B1	3/2003	McCormack et al.	713/310
6,541,878	B1	4/2003	Diab	307/17
6,762,675	B1	7/2004	Cafiero et al.	340/10.42
6,804,351	B1	10/2004	Karam	379/413
2002/0063584	A1	5/2002	Molenda et al.	327/67
2002/0180592	A1*	12/2002	Gromov	340/310.01
2003/0087670	A1*	5/2003	Muir	455/557
2004/0156496	A1	8/2004	Karam	379/413

FOREIGN PATENT DOCUMENTS

WO WO99/553408 10/1999

OTHER PUBLICATIONS

Daniel Dove, Powepoint Presentation, "Power over the DTE,"30 pages, Jan. 2000.
 Robert Muir, Powerpoint Presentation: "Update on Diode Discovery Process," 30 pages, May 2000.

"Data Terminal Equipment (DTE) Power via Media Dependent Interface (MDI)", IEEE P802.3af/D3.01 Revision of IEEE Std. 802.3-2000), 55 pages, May 2002.

"33. Data Terminal Equipment (DTE) Power via Media Dependent Interface (MDI)", Draft Supplement to IEEE Standard 802.3 (IEEE Draft P802.3af/D3.2), pp. 35-38, Sep. 5, 2002.

"Amendment: Data Terminal Equipment (DTE) Power via Media Dependent Interface (MDI)", IEEE Draft P802.3af/D4.3, (IEEE Standards Department, Draft Amendment 802-3-2002), 31 Pages , May 2003.

Hugh Barrass, "Multi-Pair Aggregate Power Distribution"—U. S. Appl. No. 10/287,886, pp. 1-25, Nov. 4, 2002.

Jeffrey D. Provost, "Inline Power Control"—U.S. Appl. No. 10/618,211, pp. 1-15, Jul. 11, 2003.

Daniel C. Biederman, "Inline Power Based Device Communications"—U.S. Appl. No. 10/651,596, pp. 1-27, Aug. 29, 2003.

Cafiero, et al. "Method and Apparatus for Remote Powering of Device Connected to Network" —U.S. Appl No. 10/836,923, pp. 1-16, Apr. 29, 2004.

Roger A. Karam , "Method and Apparatus for Detecting a Compatible Phantom Powered Device Using Common Mode Signaling"—U.S. Appl. No. 10/855.212, pp. 1-29, May 26, 2004.

Schottkky Rectifier, " *International R Rectifier*", Bullentin PD-20558 rev. E, 5 pages, Jan. 2003.

Lan Man Standards Committee of the IEEE Computer Socieity, "*Amendment: Data Terminal Equipment (DTE) Power via Media Dependent Interface (MDI)*", IEEE Draft P802.3af/D4.01., 128 pages, Jan. 2003.

* cited by examiner

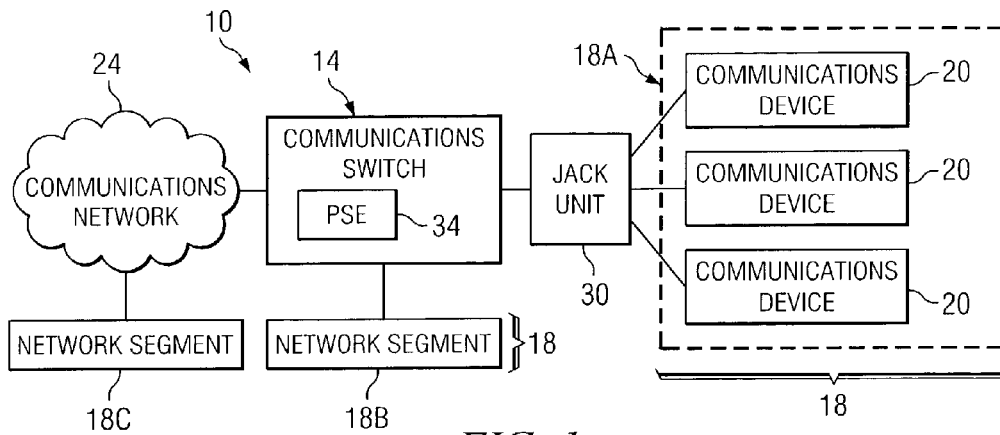

FIG. 1

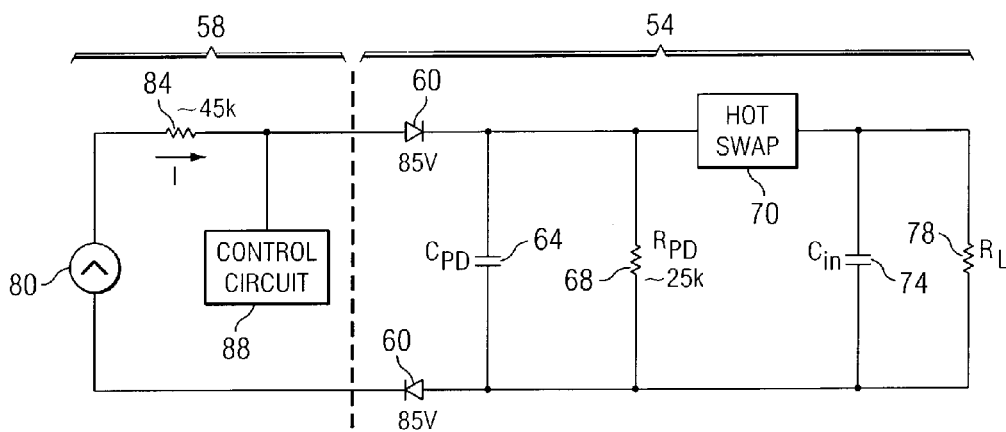

FIG. 2A

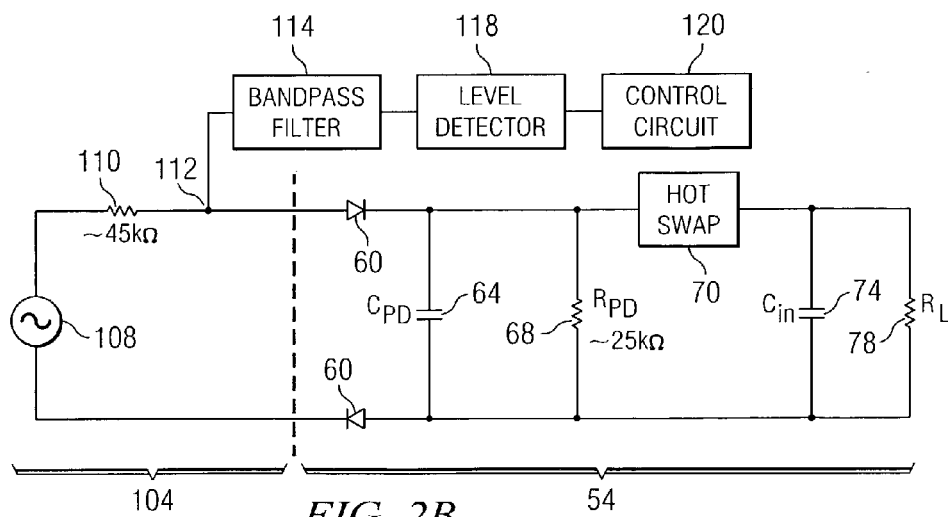

FIG. 2B

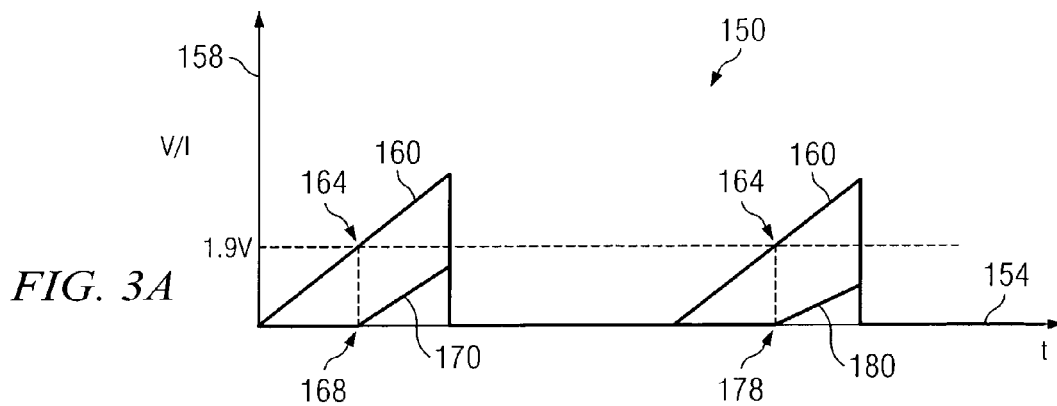

FIG. 3A

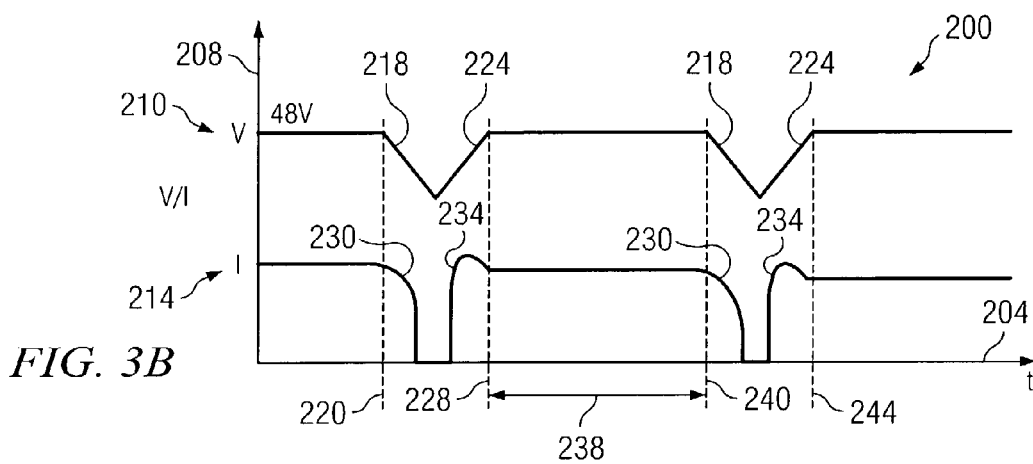

FIG. 3B

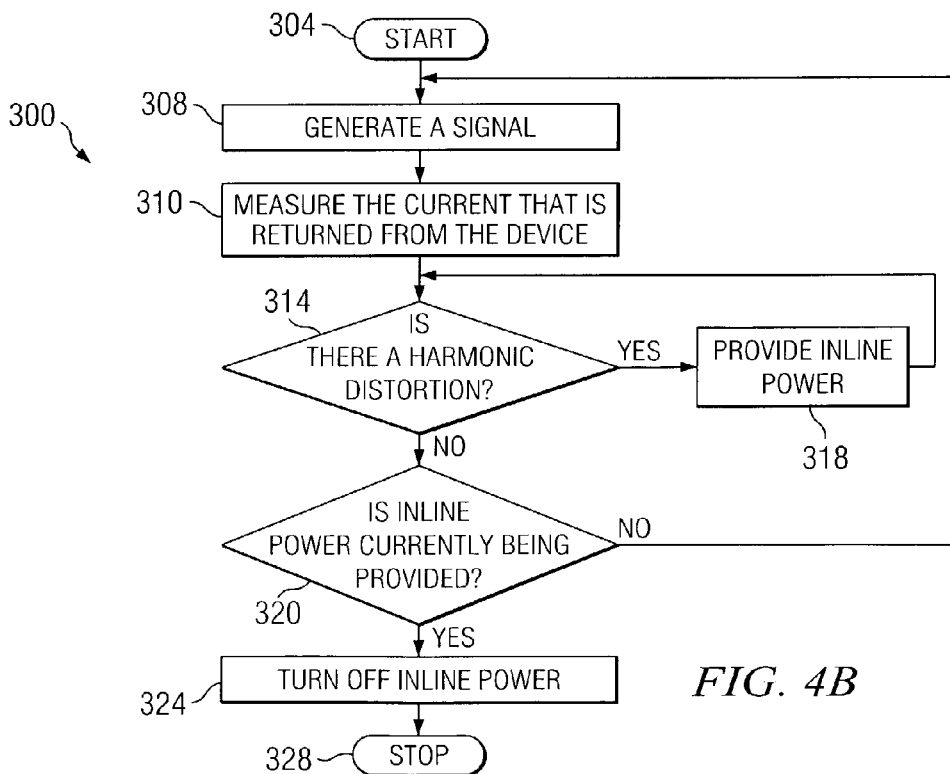

FIG. 4B

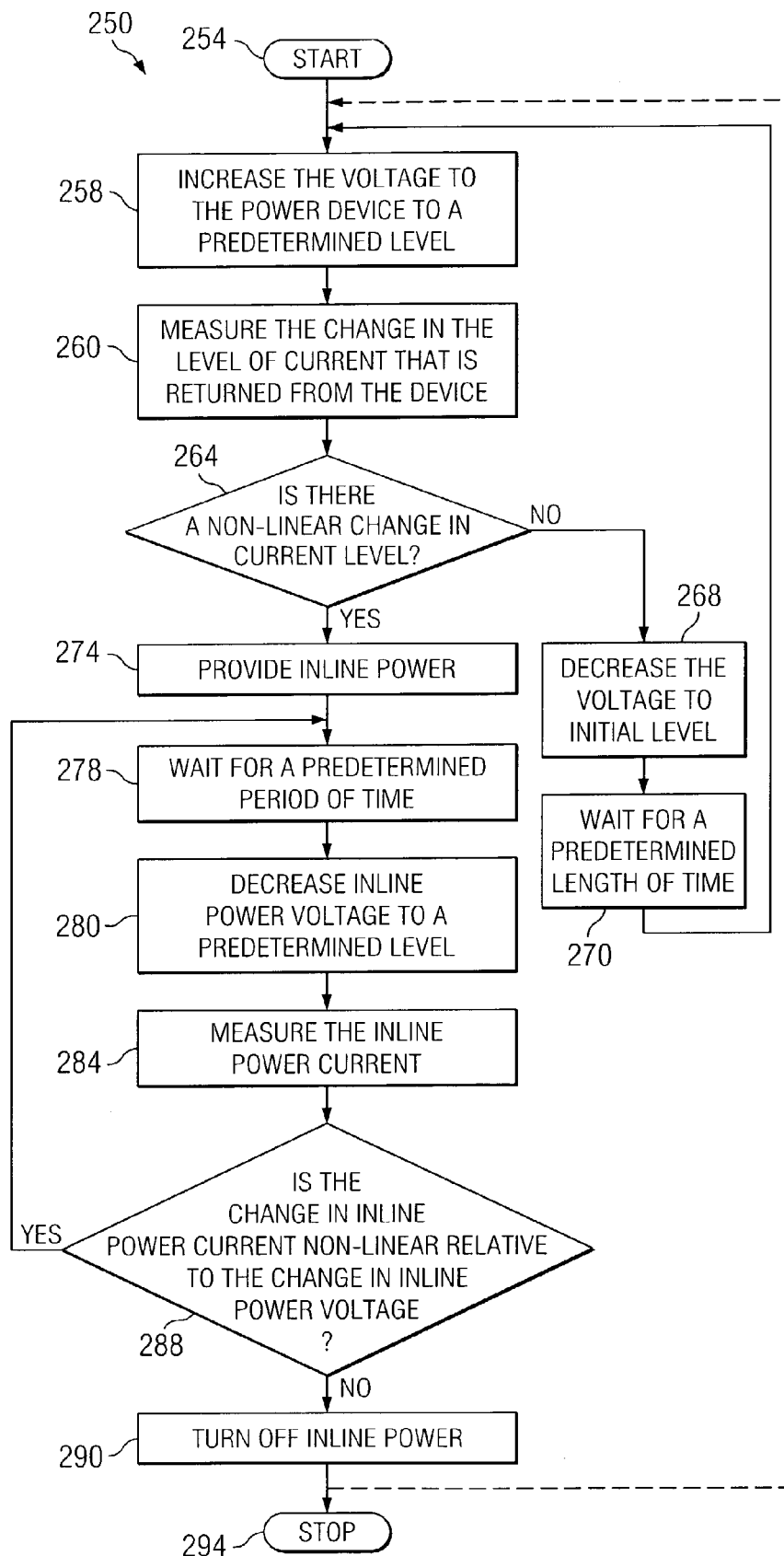

FIG. 11

Explore Litigation Insights

Docket Alarm provides insights to develop a more informed litigation strategy and the peace of mind of knowing you're on top of things.

Real-Time Litigation Alerts



Keep your litigation team up-to-date with **real-time alerts** and advanced team management tools built for the enterprise, all while greatly reducing PACER spend.

Our comprehensive service means we can handle Federal, State, and Administrative courts across the country.

Advanced Docket Research



With over 230 million records, Docket Alarm's cloud-native docket research platform finds what other services can't. Coverage includes Federal, State, plus PTAB, TTAB, ITC and NLRB decisions, all in one place.

Identify arguments that have been successful in the past with full text, pinpoint searching. Link to case law cited within any court document via Fastcase.

Analytics At Your Fingertips



Learn what happened the last time a particular judge, opposing counsel or company faced cases similar to yours.

Advanced out-of-the-box PTAB and TTAB analytics are always at your fingertips.

API

Docket Alarm offers a powerful API (application programming interface) to developers that want to integrate case filings into their apps.

LAW FIRMS

Build custom dashboards for your attorneys and clients with live data direct from the court.

Automate many repetitive legal tasks like conflict checks, document management, and marketing.

FINANCIAL INSTITUTIONS

Litigation and bankruptcy checks for companies and debtors.

E-DISCOVERY AND LEGAL VENDORS

Sync your system to PACER to automate legal marketing.