



United States Patent [19]

Smith

[11] Patent Number: **5,321,372**

[45] Date of Patent: **Jun. 14, 1994**

- [54] **APPARATUS AND METHOD FOR TERMINATING CABLES TO MINIMIZE EMISSIONS AND SUSCEPTIBILITY**
- [75] Inventor: **Robert W. Smith, Los Altos, Calif.**
- [73] Assignee: **SynOptics Communications, Inc., Santa Clara, Calif.**
- [21] Appl. No.: **1,809**
- [22] Filed: **Jan. 8, 1993**
- [51] Int. Cl.⁵ **H03H 7/00**
- [52] U.S. Cl. **333/1; 333/12; 333/22 R; 174/34; 379/416**
- [58] Field of Search **333/1, 12, 22 R; 307/89-91; 174/32-34, 36; 379/398, 416**

5,113,159 5/1992 Adriaensens et al. 333/12

FOREIGN PATENT DOCUMENTS

714544 12/1941 Fed. Rep. of Germany 333/1
79551 6/1981 Japan 333/22 R

Primary Examiner—Paul Gensler
Attorney, Agent, or Firm—Blakely, Sokoloff, Taylor & Zafman

[57] ABSTRACT

In a computer network having a cable for transmission of electrical signals between data terminal equipment and a device used to control and route data in the network, an apparatus for terminating the cable to minimize emissions radiating from the cable and susceptibility of the cable to outside interferences. The cable is comprised of unshielded twisted pairs of wires. Each twisted pair is individually terminated into a matching input impedance. The difference signals being conducted in each twisted pair produces common mode currents which sets up standing waves through the cable. Consequently, at each end of the cable, the common mode of the twisted pairs is terminated into a load having an impedance approximately equal to the common mode impedance of the twisted pairs. These loads effectively dissipate the energy from the standing waves, thereby minimizing emissions. Reciprocally, susceptibility is likewise minimized.

[56] References Cited

U.S. PATENT DOCUMENTS

- 1,998,960 4/1935 Kaar .
- 2,026,308 12/1935 Ganz .
- 2,222,406 11/1940 Crossley .
- 2,280,950 4/1942 Harder .
- 3,705,365 12/1972 Szabo et al. 333/12
- 3,731,234 5/1973 Collins 333/1
- 4,056,790 11/1977 Pospischil et al. 333/5
- 4,697,051 9/1987 Beggs et al. 178/63 D
- 4,751,607 6/1988 Smith 361/119
- 4,755,629 7/1988 Beggs et al. 174/34
- 4,823,095 4/1989 Afallah et al. 333/22 R
- 4,860,343 8/1989 Zetena, Jr. 379/110
- 4,873,393 10/1989 Friesen et al. 174/34
- 5,027,088 6/1991 Shimizu et al. 333/1

17 Claims, 3 Drawing Sheets

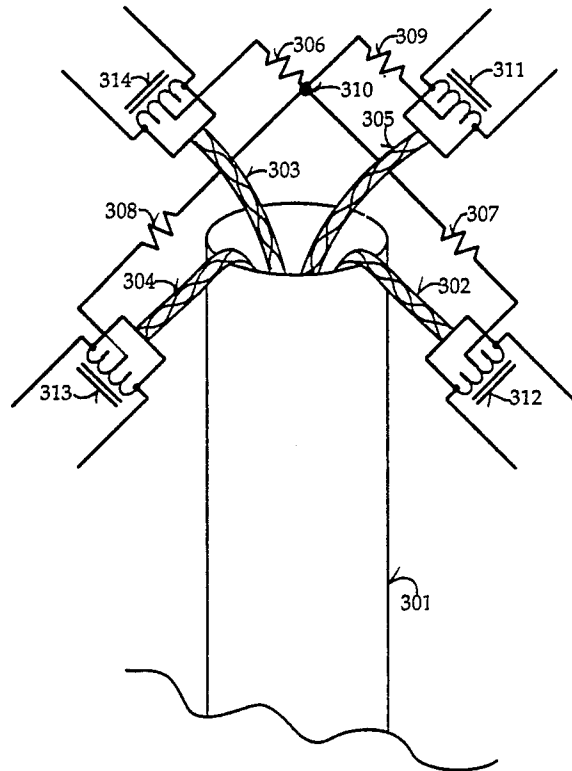

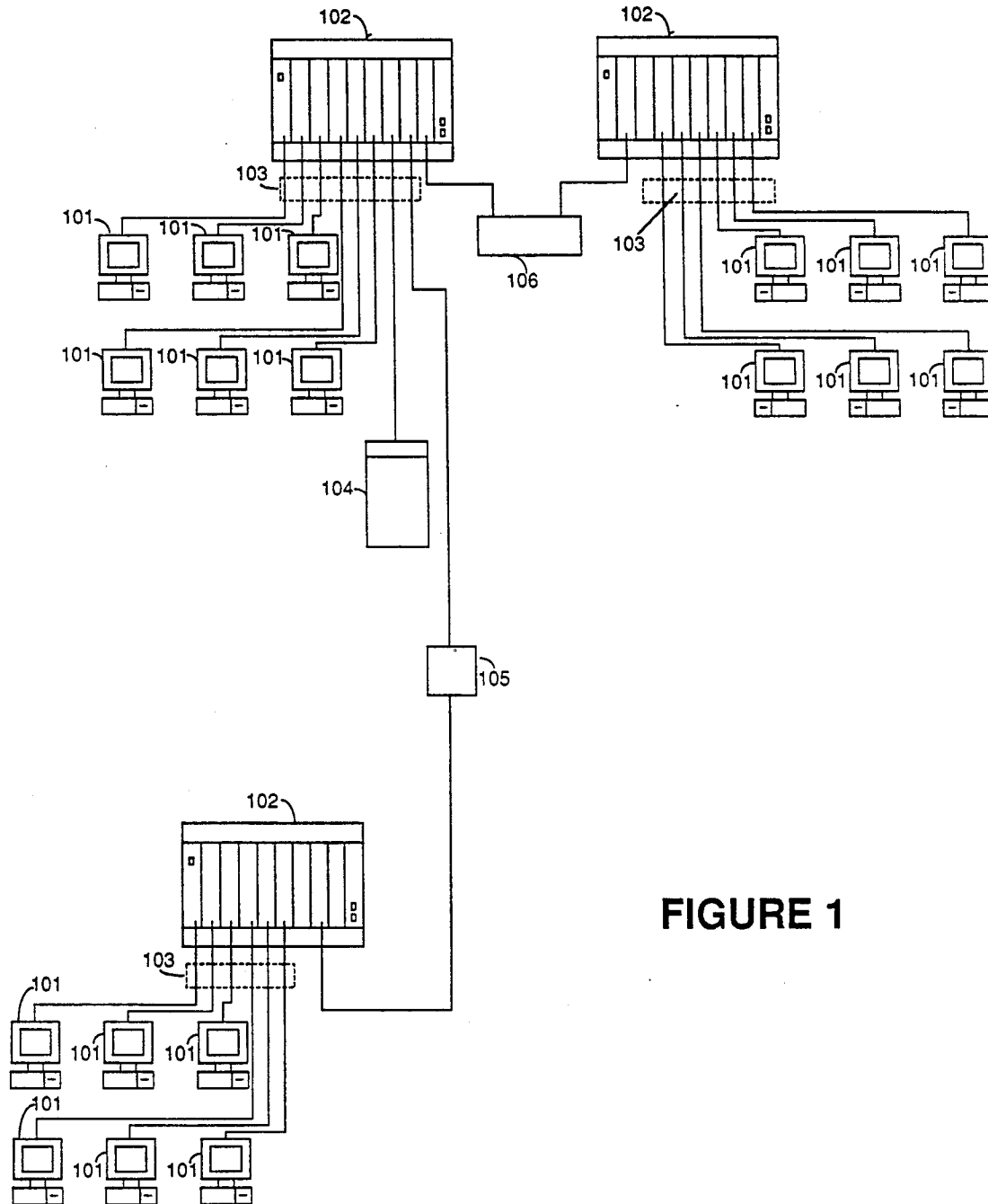

FIGURE 1

Figure 2

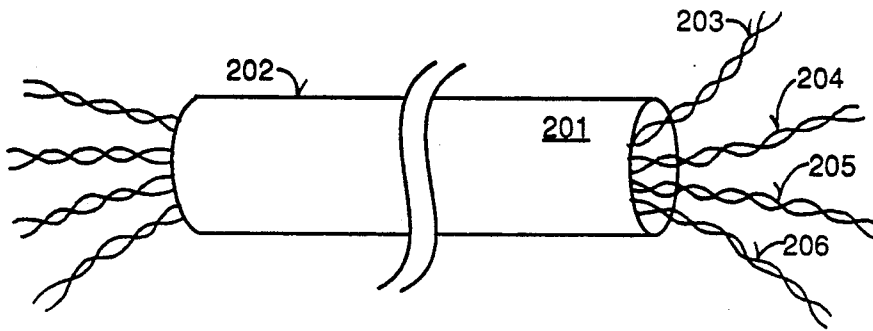

Figure 3

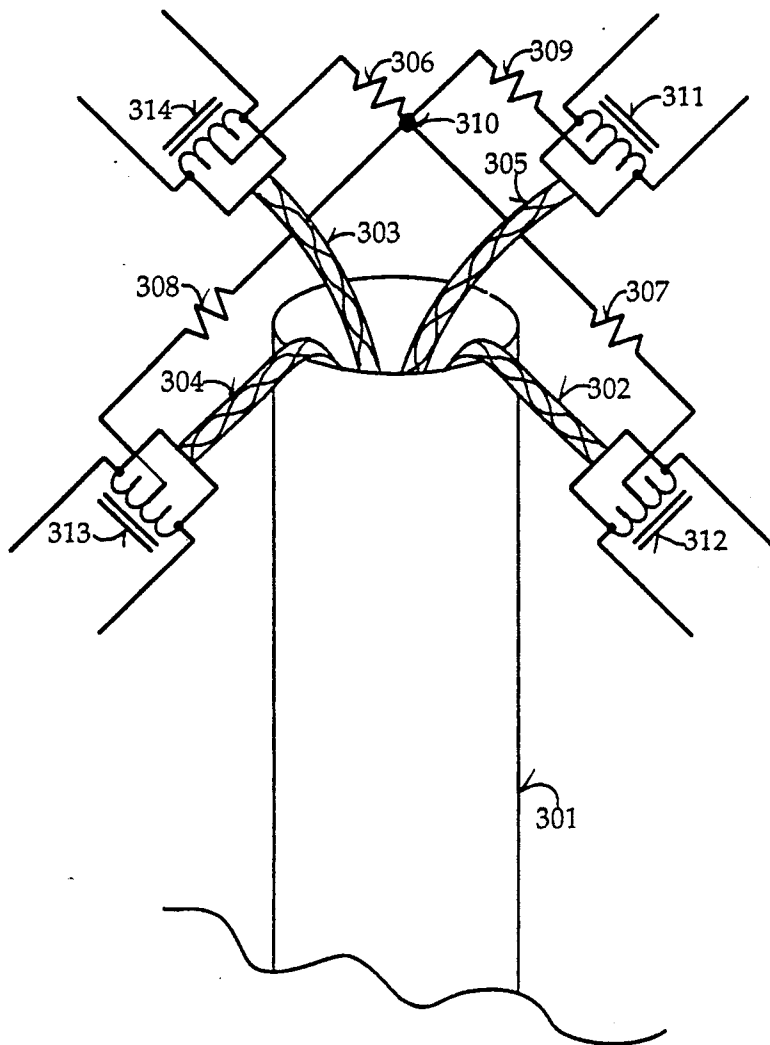
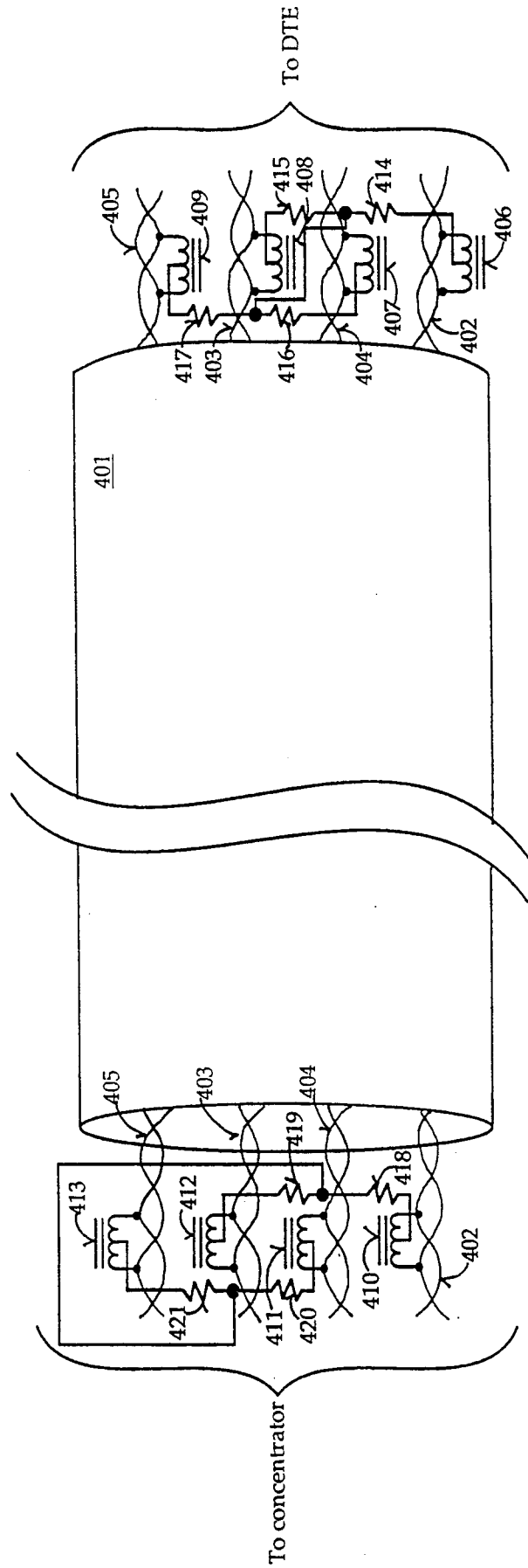

Figure 4



APPARATUS AND METHOD FOR TERMINATING CABLES TO MINIMIZE EMISSIONS AND SUSCEPTIBILITY

FIELD OF THE INVENTION

The present invention relates to the field of transmission lines. More particularly, the present invention pertains to an apparatus and method for terminating twisted pair cables to minimize emissions and susceptibility.

BACKGROUND OF THE INVENTION

In the field of computer systems, computer networks have enjoyed increasing popularity because of their versatility, flexibility, and economy. In contrast to powerful, centralized and costly "mainframes," wherein processing is routed to and performed by the mainframe computer, a computer network typically distributes processing to various autonomous computers. These individual computers are coupled together so that each computer in the network can communicate with other computers connected to the network. This arrangement allows end users to work on a joint project on separate computers by sharing files and swapping information over the network. Furthermore, application programs, databases, and peripheral hardware such as printers, disk drives, etc., can be shared amongst the various end users. Thereby, information and computing resources can readily be pooled amongst individuals and work groups. In addition, reliability is improved because a breakdown of one computer on the network does not result in shutting down or crashing the entire computer network. The other parts of the computer network can continue to function while the particular failed component is being repaired. Moreover, it is a relatively simple procedure to upgrade an existing computer network by hooking up additional computers and network control equipment on an as-needed basis.

Typically, a computer network is comprised of a number of data terminal equipment (DTE) which are coupled together by transmission lines. DTEs include personal computers, workstations, an input terminal, etc. Each DTE has a transceiver which couples the DTE to the transmission line. The transceiver transmits data onto and receives data from the transmission lines as well as performing any necessary signal conversions. Numerous transmission lines conduct digital bits of data between the DTEs. Often, the transmission lines are connected to a hub or concentrator which is used to route and manage signal traffic on the network. To expand a computer network, repeaters are used to copy and forward bits of data from one network to another; bridges are implemented to interface networks having different protocols; and routers are used for efficiently directing data packets to their final destination.

Presently, there exists many different types of media which can be used for propagating the transmission of data between the various devices of a computer network. The different types of media include unshielded twisted pair wiring, shielded twisted pair wiring, coaxial cables, and fiber optic cables. Traditionally, electrical communications were conducted over two insulated copper wires twisted together, hence the term twisted pair wiring. However, twisted pair wiring is susceptible to outside interference which introduces distortions. The distortions caused by outside sources increase with longer distances and higher data rates. These distortions

can lead to signal errors. Also, signals being conducted on these twisted pairs suffer from attenuation.

Increasing the signal strength addresses both these issues, but it also produces higher levels of emissions from the twisted pair wires. Government regulations mandate that emissions be limited to a particular level in order to minimize interferences with other apparatus. Thus, the signal strength for twisted pairs is governed by the standards set forth by the FCC. Sometimes, a shielding made of wire mesh or foil having a high permeability is used to surround the twisted pair wiring. One such implementation wherein four twisted shielded pairs for conducting differential signals, a 12 volt power line, and a master shielding and insulation layer encompassing all the wires is known as an Attachment Unit Interface (AUI) cable. For broadband and many baseband systems, an alternative to twisted pairs is coaxial cables. Coaxial cables have a single center conductor surrounded by an insulator, which is then enclosed by a metal shield such as a wire mesh or foil. Coaxial cables can handle greater bandwidths and are less susceptible to outside noise. However, coaxial cables are typically more expensive than twisted pairs.

Fiber optic cables are also being implemented in computer networks. Fiber optic cables are generally immune to electrical noise and are capable of handling very high bandwidth and transmission speed. However, splicing and tapping fiber optic cables is an expensive and difficult process. Moreover, fiber optic cables are very expensive. Hence, fiber optic cables are typically applied for long distances and heavy traffic.

Choosing among these various different media is a matter of tradeoffs. For most small local area networks (LANs), cost is of paramount concern. Significant costs are incurred not only for purchasing the medium itself but also for physically routing the medium to each of the various terminals. Costs could be greatly reduced if the network could take advantage of an already existing medium. One such medium is the telephone lines already existing and installed in virtually all office buildings, factories, and homes. These same telephone lines comprising twisted pair wiring can be used to conduct digital signals for computers rather than analog signals for phone systems. The disadvantage with using telephone wiring is that they are limited to short run lengths because of the susceptibility and emissions problems inherent to all twisted pair wiring. In some cases, longer lengths are required than can be met by telephone lines. Consequently, more expensive medium have to be bought and installed in these circumstances.

Therefore, there is a need in the prior art for an apparatus and method for minimizing the susceptibility and emissions of twisted pair wiring in order that longer lengths can be implemented to conduct digital signals in a computer network. It would also be highly preferable for the apparatus and method to be inexpensive and easy to implement.

SUMMARY OF THE INVENTION

In response to the shortcomings associated with prior art twisted pair cables used in the transmission of digital signals in a computer network, the present invention minimizes emissions radiating from such a cable and the susceptibility of signals on the cable to outside interferences. This is accomplished by terminating each twisted pair into a matching input impedance of either a data terminal equipment, such as a personal computer, or a

Explore Litigation Insights

Docket Alarm provides insights to develop a more informed litigation strategy and the peace of mind of knowing you're on top of things.

Real-Time Litigation Alerts



Keep your litigation team up-to-date with **real-time alerts** and advanced team management tools built for the enterprise, all while greatly reducing PACER spend.

Our comprehensive service means we can handle Federal, State, and Administrative courts across the country.

Advanced Docket Research



With over 230 million records, Docket Alarm's cloud-native docket research platform finds what other services can't. Coverage includes Federal, State, plus PTAB, TTAB, ITC and NLRB decisions, all in one place.

Identify arguments that have been successful in the past with full text, pinpoint searching. Link to case law cited within any court document via Fastcase.

Analytics At Your Fingertips



Learn what happened the last time a particular judge, opposing counsel or company faced cases similar to yours.

Advanced out-of-the-box PTAB and TTAB analytics are always at your fingertips.

API

Docket Alarm offers a powerful API (application programming interface) to developers that want to integrate case filings into their apps.

LAW FIRMS

Build custom dashboards for your attorneys and clients with live data direct from the court.

Automate many repetitive legal tasks like conflict checks, document management, and marketing.

FINANCIAL INSTITUTIONS

Litigation and bankruptcy checks for companies and debtors.

E-DISCOVERY AND LEGAL VENDORS

Sync your system to PACER to automate legal marketing.