

**UNITED STATES DISTRICT COURT
CENTRAL DISTRICT OF CALIFORNIA**

CIVIL MINUTES – GENERAL

Case No.	LA CV14-02454 JAK (JEMx)	LA CV14-03111 JAK (JEMx)	Date	April 17, 2015
	LA CV14-02457 JAK (JEMx)	LA CV14-03113 JAK (JEMx)		
	LA CV14-02962 JAK (JEMx)	LA CV14-03114 JAK (JEMx)		
	LA CV14-02963 JAK (JEMx)	SA CV14-00491 JAK (JEMx)		
	LA CV14-03108 JAK (JEMx)	SA CV14-00497 JAK (JEMx)		
	LA CV14-03109 JAK (JEMx)			
Title	Signal IP v. American Honda Motor Co., Inc.	Signal IP v. BMW of North America, LLC, et al.		
	Signal IP v. Kia Motors America, Inc.	Signal IP v. Volkswagen Group of America, Inc.		
	Signal IP v. Nissan North America, Inc.	Signal IP v. Porsche Cars of North America, Inc.		
	Signal IP v. Subaru of America, Inc.	Signal IP v. Mazda Motor of America, Inc.		
	Signal IP v. Jaguar Land Rover North Am., LLC	Signal IP v. Mitsubishi Motors North America, Inc.		
	Signal IP v. Mercedes-Benz USA, LLC, et al.			

Present: The Honorable	JOHN A. KRONSTADT, UNITED STATES DISTRICT JUDGE
Andrea Keifer	Not Reported
Deputy Clerk	Court Reporter / Recorder
Attorneys Present for Plaintiff:	Attorneys Present for Defendants:
Not Present	Not Present

Proceedings: (IN CHAMBERS) ORDER RE CLAIM CONSTRUCTION

TABLE OF CONTENTS

I. INTRODUCTION.....4

II. FACTUAL BACKGROUND4

III. LEGAL STANDARD5

A. Claim Construction5

B. Means Plus Function Claim Limitations.....7

C. Definiteness7

IV. ANALYSIS8

A. The ‘927 Patent8

 Term No. 1: “In a radar system wherein a host vehicle uses radar to detect a target vehicle in a blind spot of the host vehicle driver, a method of improving the perceived zone of coverage response automotive radar comprising the steps of” (Claim 1) 12

 Term No. 2: “Variable Sustain Time” (Claims 1 and 2)..... 14

 Term No. 3: “Wherein the Zone of Coverage Appears to Increase According to the Variable Sustain Time” / “Improving the Perceived Zone of Coverage” (Claim 1) 19

**UNITED STATES DISTRICT COURT
CENTRAL DISTRICT OF CALIFORNIA**

CIVIL MINUTES – GENERAL

Case No. LA CV14-02454 JAK (JEMx) -- AND RELATED CASES

Date April 17, 2015

Title Signal IP v. American Honda Motor Co., Inc. -- AND RELATED CASES

Term No. 4:	“A Threshold Time” (Claim 1)	23
Term No. 5:	“Improving the Perceived Zone of Coverage” (Claim 1)	24
B. The ‘375 Patent		24
Term No. 6:	“Force Distribution” (Claim 1).....	29
Term No. 7:	“On the Passenger Seat” (Claim 1)	33
Term No. 8:	“Seat Area” (Claim 1).....	35
Term No. 9:	“Sensor Array / Array of Force Sensors” (Claim 1).....	36
Term No. 10:	“Seat Area Threshold Force” (Claim 1).....	39
Term No. 11:	“Concentrated” (Claim 1)	41
C. The ‘007 Patent		43
Term No. 12:	“Seat Sensors” (Claims 1, 17, 18 & 19).....	48
Term No. 13:	“Lock Flag” / “Flag” (Claims 1, 17).....	51
Term No. 14:	“For a Time” / “For a Given Time” (Claims 1 & 17).....	53
Term No. 15:	“A Second Threshold” (Claim 20).....	56
Term No. 16:	“Relative Weight Parameter” (Claims 1, 17, 20-22).....	60
Term No. 17:	“Setting” / “Set a Lock Flag When . . .” (Claims 1, 17).....	63
Term No. 18:	“A Level Indicative of an Empty Seat” (Claims 1, 17).....	65
Term No. 19:	“Arrayed in an Interface Defined by the Bottom Surface” (Claim 19)	68
Term No. 20:	“Means for Selectively Allowing Deployment According to the Outputs of Seat Sensors Responding to the Weight of an Occupant” (Claim 1)”	70
Term No. 21:	“Means for Inhibiting and Allowing Deployment . . .” (Claim 17).....	73
D. The ‘486 Patent		75
Term No. 22:	“Warning Distance Based upon the Current Steering Angle”/ “Desired Warning Distance” (Claims 21 & 28)	79
E. The ‘601 Patent		85

**UNITED STATES DISTRICT COURT
CENTRAL DISTRICT OF CALIFORNIA**

CIVIL MINUTES – GENERAL

Case No. LA CV14-02454 JAK (JEMx) -- AND RELATED CASES

Date April 17, 2015

Title Signal IP v. American Honda Motor Co., Inc. -- AND RELATED CASES

Term Nos. 23 & 25: [Listed in Chart Below].....	88
Term No. 24: “Threshold Torque Range Indicative of Conditions of Relatively Low Vehicle Torque Demand” (Claim 8).....	93
Term No. 25: [See Term No. 23 (above)].....	97
Term No. 26: “Regions of Relatively High and Low Efficiency” / “Region of -Efficiency” / “Region of High Efficiency” / “Relatively High and Relatively Low Efficiency (Claims 15, 17).....	97
Term No. 27: “Mapping” / “Mapping the Respective Regions of Relatively High and Low Efficiency in an Efficiency Map for the Propulsion Unit” (Claims 15 & 17).....	100
Term No. 28: “Efficiency Map” (Claims 15 & 17).....	101
F. The ‘374 Patent.....	105
Term No. 29: “All Having the Same Data Format but Distinctive Codes for Tire Transmitters and Vehicle Function Transmitters” (Claim 1).....	108
Term No. 30: “A Switch Activated by a Vehicle User” (Claim 3).....	111
Term No. 31: “Sign Up Message” (Claim 3).....	113
Term No. 32: “Each Tire” (Claim 3).....	116
G. The ‘775 Patent.....	117
Term No. 33: “Message Rate” (Claim 6).....	120
Term No. 34: “Message Rate Interval” (Claim 6).....	122
Term No. 35: “Message” (Claim 6).....	127
Term No. 36: “Complete Message” / “Fragment of a Complete Message” (Claim 6)....	128
IV. CONCLUSION.....	132

**UNITED STATES DISTRICT COURT
CENTRAL DISTRICT OF CALIFORNIA**

CIVIL MINUTES – GENERAL

Case No. LA CV14-02454 JAK (JEMx) -- AND RELATED CASES

Date April 17, 2015

Title Signal IP v. American Honda Motor Co., Inc. -- AND RELATED CASES

I. INTRODUCTION

In April, 2014, Plaintiff Signal IP (“Plaintiff”) brought separate actions against Defendants Mitsubishi Motors North America, Inc. (“Mitsubishi”), Mazda Motor of America, Inc. (“Mazda”), BMW of North America, LLC (“BMW”), Porsche Cars North America, Inc. (“Porsche”), American Honda Motor Co., Inc. and Honda of America Mfg., Inc. (collectively, “Honda”), Nissan North America, Inc. (“Nissan”), Mercedes-Benz USA LLC (“Mercedes”), Volkswagen Group of America, Audi of America, LLC, and Bentley Motors, Inc. (collectively “VW/Bentley”), Jaguar Land Rover North America, LLC (“Jaguar”), Subaru of America, Inc. (“Subaru”), and Kia Motors America, Inc. (“Kia”) (collectively, “Defendants”), alleging infringement as to one or more of seven U.S. Patents (the “Patents in Suit”).¹

The parties filed their Joint Claim Construction and Prehearing Statement (“Joint Statement”) on January 30, 2015, *Signal IP, Inc. v. Am. Honda Motor Co., Inc.*, No. LA CV14-2454, Dkt. 46, and their Amended Joint Claim Construction Brief (“Joint Brief”) and Joint Evidentiary Appendix (“JA”) on March 11, 2015, *Signal IP, Inc. v. Am. Honda Motor Co., Inc.*, No. LA CV14-2454, Dkts. 52-53.² The parties disputed the construction of 36 terms. *Id.* The week before the hearing, the parties came to agreement on one of those terms. This left 35 for construction. Notice of Agreed Construction as to Claim Term Threshold Time, Dkt. 55.

A *Markman* hearing was held on March 31, 2015, and the matter was taken under submission. Minutes of *Markman* Hearing, Dkt. 57. The disputed terms are construed, or otherwise addressed, in this Order.

II. FACTUAL BACKGROUND

The Patents in Suit are: U.S. Patent No. 5,714,927 (“the ‘927 Patent”), “Method of Improving Zone of Coverage Response of Automotive Radar”; U.S. Patent No. 5,732,375 (“the ‘375 Patent”), “Method of Inhibiting or Allowing Airbag Deployment”; U.S. Patent No. 6,012,007 (“the ‘007 Patent”), “Occupant Detection Method and System for Air Bag System”; U.S. Patent No. 6,434,486 (“the ‘486 Patent”), “Technique for Limiting the Range of an Object Sensing System in a Vehicle”; U.S. Patent No. 6,775,601 (“the ‘601 Patent”), “Method and Control System for Controlling Propulsion in a Hybrid Vehicle”; U.S. Patent No. 5,463,374 (“the ‘374 Patent”), “Method and Apparatus for Tire Pressure Monitoring and for Shared Keyless Entry Control”; and U.S. Patent No. 5,954,775 (“the ‘775 Patent”), “Dual-rate Communication Protocol.” Joint Report, Dkt.35 at 3-4.

The following table shows the patents that are asserted against each Defendant.

¹ Several additional defendants were named in cases that have been dismissed or transferred from this District.

² Unless otherwise noted, all references to a docket number are to *Signal IP, Inc. v. Am. Honda Motor Co., Inc.*, No. LA CV 14-2454.

**UNITED STATES DISTRICT COURT
CENTRAL DISTRICT OF CALIFORNIA**

CIVIL MINUTES – GENERAL

Case No. LA CV14-02454 JAK (JEMx) -- AND RELATED CASES

Date April 17, 2015

Title Signal IP v. American Honda Motor Co., Inc. -- AND RELATED CASES

Patent	Honda	Kia	Mazda	Mitsubishi	Nissan	Subaru	Jaguar	Mercedes	BMW	VW	Porsche
'601 Patent	X	X			X	X		X	X	X	X
'486 Patent	X	X	X	X	X	X		X	X	X	X
'775 Patent								X	X	X	
'375 Patent	X	X	X	X	X				X	X	
'007 Patent	X	X	X	X	X	X		X	X	X	X
'927 Patent	X	X	X		X		X	X	X	X	X
'374 Patent			X	X	X	X					

III. LEGAL STANDARD

A. Claim Construction

Claim construction is the process of determining the meaning and scope of patent claims. *Markman v. Westview Instruments, Inc.*, 52 F.3d 967, 976 (Fed. Cir. 1995) (en banc), *aff'd*, 517 U.S. 370 (1996). It is a matter that is addressed by the district court; in general, the findings are reviewed *de novo* on appeal, although underlying factual determinations are reviewed for clear error. *Teva Pharm. USA, Inc. v. Sandoz, Inc.*, 135 S. Ct. 831, 840-41 (2015).

“[T]he words of a claim are generally given their ordinary and customary meaning,” which is “the meaning that the term would have to a person of ordinary skill in the art in question at the time of the invention, *i.e.*, as of the effective filing date of the patent application.” *Phillips v. AWH Corp.*, 415 F.3d 1303, 1313 (Fed. Cir. 2005) (internal citations and quotations omitted). “In some cases, the ordinary meaning of claim language as understood by a person of skill in the art may be readily apparent even to lay judges, and claim construction in such cases involves little more than the application of the widely accepted meaning of commonly understood words.” *Id.* at 1314. “In such circumstances, general purpose dictionaries may be helpful.” *Id.* “In many cases that give rise to litigation, however, determining the ordinary and customary meaning of the claim requires examination of terms that have a particular meaning in a field of art.” *Id.*

“Because the meaning of a claim term as understood by persons of skill in the art is often not immediately apparent, and because patentees frequently use terms idiosyncratically, the court looks to ‘those sources available to the public that show what a person of skill in the art would have understood disputed claim language to mean.’” *Id.* (quoting *Innova/Pure Water, Inc. v. Safari Water Filtration Sys., Inc.*, 381 F.3d 1111, 1116 (Fed. Cir. 2004)). “Those sources include ‘the words of the claims themselves, the remainder of the specification, the prosecution history, and extrinsic evidence concerning relevant scientific principles, the meaning of technical terms, and the state of the art.’” *Id.*

Claim construction “begins and ends” with the words of the claims. *Renishaw PLC v. Marposs Societa’ per Azioni*, 158 F.3d 1243, 1248 (Fed. Cir. 1998). “Quite apart from the written description and the

**UNITED STATES DISTRICT COURT
CENTRAL DISTRICT OF CALIFORNIA**

CIVIL MINUTES – GENERAL

Case No. LA CV14-02454 JAK (JEMx) -- AND RELATED CASES

Date April 17, 2015

Title Signal IP v. American Honda Motor Co., Inc. -- AND RELATED CASES

prosecution history, the claims themselves provide substantial guidance as to the meaning of particular claim terms.” *Phillips*, 415 F.3d at 1314. “[T]he context in which a term is used in the asserted claim can be highly instructive.” *Id.* In addition to the words of the claim(s) being construed, “[o]ther claims of the patent in question, both asserted and unasserted, can also be valuable sources of enlightenment as to the meaning of a claim term. Because claim terms are normally used consistently throughout the patent, the usage of a term in one claim can often illuminate the meaning of the same term in other claims.” *Id.* “Differences among claims can also be a useful guide in understanding the meaning of particular claim terms.” *Id.* “For example, the presence of a dependent claim that adds a particular limitation gives rise to a presumption that the limitation in question is not present in the independent claim.” *Id.* at 1314-15. However, “[c]laim differentiation is a guide, not a rigid rule.” *Laitram Corp. v. Rexnord, Inc.*, 939 F.2d 1533, 1538 (Fed. Cir. 1991) (citing *Autogiro Co. of America v. United States*, 384 F.2d 391, 404 (Ct. Cl. 1967) (“If a claim will bear only one interpretation, similarity will have to be tolerated.”)).

“[C]laims must be construed so as to be consistent with the specification, of which they are a part.” *Merck & Co., Inc. v. Teva Pharms. USA, Inc.*, 347 F.3d 1367, 1371 (Fed. Cir. 2003) (citations omitted). “[T]he person of ordinary skill in the art is deemed to read the claim term not only in the context of the particular claim in which the disputed term appears, but in the context of the entire patent, including the specification.” *Phillips*, 415 F.3d at 1313. “[T]he specification ‘is always highly relevant to the claim construction analysis. Usually, it is dispositive; it is the single best guide to the meaning of a disputed term.’” *Id.* at 1315 (quoting *Vitronics Corp. v. Conceptoronic, Inc.*, 90 F.3d 1576, 1582 (Fed. Cir. 1996)).

“[T]he specification may reveal a special definition given to a claim term by the patentee that differs from the meaning it would otherwise possess. In such cases, the inventor’s lexicography governs.” *Phillips*, 415 F.3d at 1316 (citations omitted). “In other cases, the specification may reveal an intentional disclaimer, or disavowal, of claim scope by the inventor. In that instance as well, the inventor has dictated the correct claim scope, and the inventor’s intention, as expressed in the specification, is regarded as dispositive.” *Id.* (citations omitted).

Notwithstanding the importance of a specification, limitations in the specification must not be read into the claims absent lexicography or disclaimer/disavowal. The Federal Circuit has “expressly rejected the contention that if a patent describes only a single embodiment, the claims of the patent must be construed as being limited to that embodiment.” *Id.* at 1323. Conversely, “an interpretation [which excludes a preferred embodiment] is rarely, if ever, correct and would require highly persuasive evidentiary support.” *Vitronics*, 90 F.3d at 1583.

The prosecution history of a patent is also relevant intrinsic evidence. Although “the prosecution history represents an ongoing negotiation between the PTO and the applicant, rather than the final product of that negotiation” and for this reason “often lacks the clarity of the specification,” the prosecution history can nonetheless “often inform the meaning of the claim language by demonstrating how the inventor understood the invention and whether the inventor limited the invention in the course of prosecution, making the claim scope narrower than it would otherwise be.” *Phillips*, 415 F.3d at 1317 (citations omitted).

“Although [the Federal Circuit has] emphasized the importance of intrinsic evidence in claim

**UNITED STATES DISTRICT COURT
CENTRAL DISTRICT OF CALIFORNIA**

CIVIL MINUTES – GENERAL

Case No. LA CV14-02454 JAK (JEMx) -- AND RELATED CASES

Date April 17, 2015

Title Signal IP v. American Honda Motor Co., Inc. -- AND RELATED CASES

construction, [it has] also authorized district courts to rely on extrinsic evidence, which ‘consists of all evidence external to the patent and prosecution history, including expert and inventor testimony, dictionaries, and learned treatises.’” *Id.* (citations omitted). The use of “technical words or phrases not commonly understood” may give rise to a factual dispute, the determination of which will precede the ultimate construction. *Teva*, 135 S.Ct. at 841, 849 (2015).

B. Means Plus Function Claim Limitations

A claim limitation may be phrased as “a means or step for performing a specified function without the recital of structure, material, or acts in support thereof.” Such limitations “shall be construed to cover the corresponding structure, material, or acts described in the specification and equivalents thereof.” 35 U.S.C. § 112(f). This “means plus function” interpretation applies “only to purely functional limitations that do not provide the structure that performs the recited function.” *Phillips*, 415 F.3d at 1311. “In construing a means plus function claim, the district court must first determine the claimed function and then identify the corresponding structure in the written description of the patent that performs that function.” *Baran v. Med. Device Techs., Inc.*, 616 F.3d 1309, 1316 (Fed. Cir. 2010). A district court should “construe the meaning of the words used to describe the claimed function, using ordinary principles of claim construction.” *Lockheed Martin Corp. v. Space Sys./Loral, Inc.*, 324 F.3d 1308, 1319 (Fed. Cir. 2003).

C. Definiteness

The patent monopoly is a property right, and “like any property right, its boundaries should be clear.” *Nautilus, Inc. v. Biosig Instruments, Inc.*, 134 S.Ct. 2120, 2124 (2014) (quoting *Festo Corp. v. Shoketsu Kinzoku Kogyo Kabushiki Co.*, 535 U.S. 722, 730 (2002)). The requirement that the claims “particularly point out and distinctly claim” the boundaries of the invention has existed since the Patent Act of 1870. *Nautilus*, 134 S. Ct. at 2125. The Patent Act of 1952, which is applicable to the patents at issue in this case that preceded the America Invents Act, requires that the specification conclude with “one or more claims particularly pointing out and distinctly claiming the subject matter which the applicant regards as his invention.” *Id.* (quoting 35 U.S.C. § 112, ¶ 2 (2006)).

In recent decisions that preceded *Nautilus*, courts held that claims failed the definiteness requirement only when they were “not amenable to construction” or “insolubly ambiguous.” See *Datamize, LLC v. Plumtree Software, Inc.*, 417 F.3d 1342, 1347 (Fed. Cir. 2005). However, *Nautilus* overturned that standard, holding instead that § 112, ¶ 2 requires that “a patent’s claims, viewed in light of the specification and prosecution history, inform those skilled in the art about the scope of the invention with reasonable certainty.” 134 S. Ct. at 2129. *Nautilus* emphasized that a patent must be precise enough to afford clear notice of what is claimed, thereby “appris[ing] the public of what is still open to them,” while recognizing that absolute precision is unobtainable. *Id.* (quoting *Markman v. Westview Instruments, Inc.*, 517 U.S. 370, 373 (1996)).

**UNITED STATES DISTRICT COURT
CENTRAL DISTRICT OF CALIFORNIA**

CIVIL MINUTES – GENERAL

Case No. LA CV14-02454 JAK (JEMx) -- AND RELATED CASES

Date April 17, 2015

Title Signal IP v. American Honda Motor Co., Inc. -- AND RELATED CASES

IV. ANALYSIS

A. The '927 Patent³

The '927 Patent was issued on February 3, 1998 to assignee Delco Electronics Corporation ("Delco"). It discloses an improved method for using side detection radar to warn a driver about objects in the blind spot of a vehicle. '927 Patent at Abstract. The '927 Patent contains 12 claims, three of which Plaintiff asserts in these cases. *Id.*; Joint Rep., Dkt. 27 at 4. The Parties dispute the construction of five terms, two of which Defendants allege are indefinite.

Generally, vehicles that use radar detection systems do so to identify nearby obstacles, or "targets." '927 Patent at 1:13-4. Such systems analyze the relative speeds of the host and target and decide whether to "report" a target. *Id.* at 1:35-39. Figure 1, which is reproduced below, shows a vehicle with side detection radar antennae behind the side view mirror. The antennae are part of a side detection system. *Id.* at 2:66-3:2. The side detection system is made up of the antennae, a signal processor, a transceiver and a microprocessor that receives and processes data. *Id.* at 3:14-24. Further, the '927 Patent incorporates by reference U.S. Patent No. 5,530,447, which discloses a method and system in which the microprocessor computes host vehicle speed to determine whether an object is a hazard. *Id.* at 3:34-38.

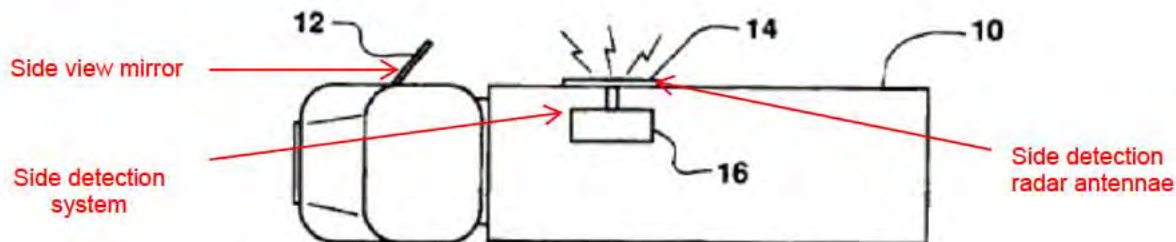

Figure 1

The system disclosed in the '927 Patent improves upon previous ones by avoiding signal dropout and improving the zone of coverage that is perceived by the driver. *Id.* at 2:9-35. The '927 Patent addresses these two issues with a single approach. Specifically, it sustains a signal for a variable time based on the vehicle speed. This increased signal length both covers up dropouts in the radar system and makes it appear that the radar system continues to sense a target even after that target has passed out of radar range. *Id.* at 2:25-35.

Figures 3a through 3d of the '927 Patent illustrate the dropout problem and the manner in which a sustained alert masks it. When a radar signal reflects off of a target vehicle's wheel wells, it creates dips in the return signal field strength. This results in dropouts in the raw alert signal, i.e. any signal received without further processing. By applying sustained alert processing, such drop-offs are not present in the signal presented to the driver. *Id.* at 3:52-4:7.

³ The '927 Patent is provided as Exhibit B, JA-0003-09.

UNITED STATES DISTRICT COURT
CENTRAL DISTRICT OF CALIFORNIA

CIVIL MINUTES – GENERAL

Case No. LA CV14-02454 JAK (JEMx) -- AND RELATED CASES

Date April 17, 2015

Title Signal IP v. American Honda Motor Co., Inc. -- AND RELATED CASES

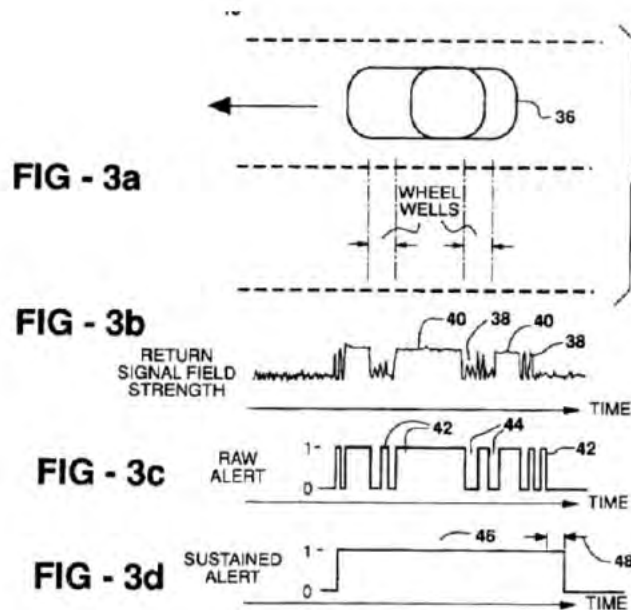

By adding “a variable sustain time . . . to each alert signal which exceeds a threshold value” this same gap-filling method also “extend[s] the perceived zone of coverage.” *Id.* at Abstract. Figure 4 of the ‘927 patent, which is reproduced below, shows the actual radar zone of coverage and the increased perceived zone that results from the variable sustain time.

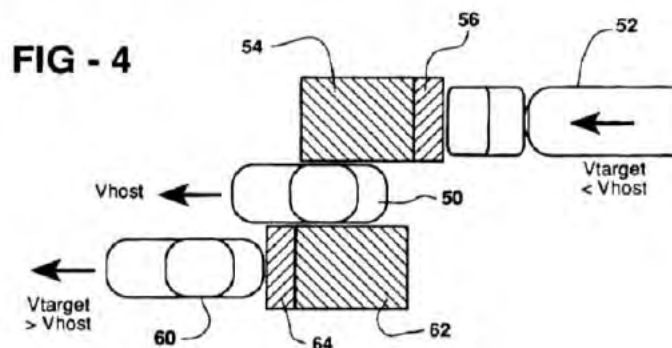

For target vehicle 52 travelling slower than the host vehicle, the radar “covers a zone 54 to provide a raw alert signal when the vehicle 52 is still in that zone.” *Id.* at 4:11-12. By sustaining the alert signal, “a zone of extension 56 is created to effectively increase the zone of coverage.” *Id.* at 4:13-14. Similarly, for target vehicle 60 travelling faster than the host vehicle, the “zone 62 actually monitored by radar is supplemented by a zone extension 64 due to the sustain period 48.” *Id.* at 4:18-19.

UNITED STATES DISTRICT COURT
CENTRAL DISTRICT OF CALIFORNIA

CIVIL MINUTES – GENERAL

Case No. LA CV14-02454 JAK (JEMx) -- AND RELATED CASES

Date April 17, 2015

Title Signal IP v. American Honda Motor Co., Inc. -- AND RELATED CASES

A signal sustaining algorithm determines how long to maintain an alert signal. *Id.* at 4:22-23. '927 Patent Figure 5 (below) depicts a flow chart of the alert signal sustaining algorithm. *Id.*

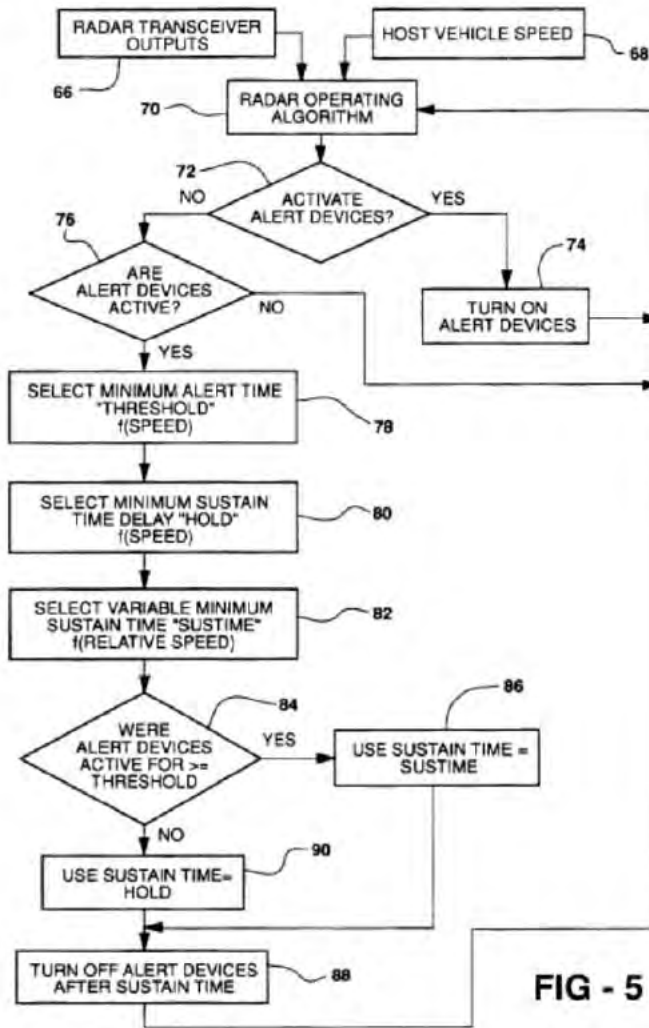

The alert device determines three variables: minimum alert time threshold "THRESHOLD," a function of vehicle speed 78; minimum sustain time delay "HOLD," a function of speed 80; and variable minimum sustain time "SUSTIME," a function of relative vehicle speed 82. *Id.* at 4:35-41.

If an alert is active for longer than the THRESHOLD time, the alert is maintained until the variable sustain time (SUSTIME) is reached; the alert then turns off. *Id.* at 4:41-44. If the alerts are active for less than the THRESHOLD time, the alert turn-off is delayed for the HOLD time. *Id.* at 4:44-46.

UNITED STATES DISTRICT COURT
CENTRAL DISTRICT OF CALIFORNIA

CIVIL MINUTES – GENERAL

Case No. LA CV14-02454 JAK (JEMx) -- AND RELATED CASES

Date April 17, 2015

Title Signal IP v. American Honda Motor Co., Inc. -- AND RELATED CASES

Suggested THRESHOLD, HOLD, and SUSTIME values vary according to vehicle speed. *Id.* at 4:37-42. Ideal THRESHOLD times are in the range of 160-300 milliseconds, decreasing stepwise as a function of speed. *Id.* at 4:53-56. This sustains the alert signal longer at higher speeds, when there is less probability of a false alarm. *Id.* at 4:53-61. HOLD values increase as a function of speed, in the 0-200 millisecond range. *Id.* at 4:61-64. Holding the signal for longer at higher speeds helps to mask flickers due to multiple reflections or weak signals from the front or rear of a target vehicle. *Id.* at 4:64-67. Suggested variable SUSTIME values decrease stepwise from 2.5-0.6 seconds as a function of relative vehicle speed, as shown in Figure 7 of the '927 Patent, which is reproduced below. *Id.* at 5:1-4. These values should extend the perceived zone of coverage by about 10 feet beyond what would occur if a sustain time were not used. *Id.* at 5:5-6.

FIG - 7

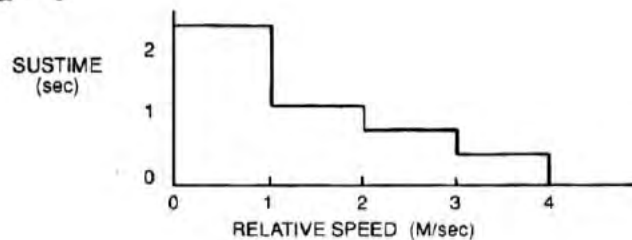

The asserted '927 Patent claims in which the disputed terms occur are reproduced below, with the disputed terms in bold:

1. In a radar system wherein a host vehicle uses radar to detect a target vehicle in a blind spot of the host vehicle driver, a method of improving the perceived zone of coverage response of automotive radar comprising the steps of:
 - determining the relative speed of the host and target vehicles;
 - selecting a **variable sustain time** as a function of relative vehicle speed;
 - detecting target vehicle presence and producing an alert command;
 - activating an alert signal in response to the alert command;
 - at the end of the alert command, determining whether the alert signal was active for a **threshold time**; and
 - if the alert signal was active for the threshold time, sustaining the alert signal for the **variable sustain time, wherein the zone of coverage appears to increase according to the variable sustain time.**
2. The invention as defined in claim 1 wherein the **variable sustain time** is an inverse function of the relative vehicle speed.

UNITED STATES DISTRICT COURT
CENTRAL DISTRICT OF CALIFORNIA

CIVIL MINUTES – GENERAL

Case No. LA CV14-02454 JAK (JEMx) -- AND RELATED CASES

Date April 17, 2015

Title Signal IP v. American Honda Motor Co., Inc. -- AND RELATED CASES

Term No. 1: "In a radar system wherein a host vehicle uses radar to detect a target vehicle in a blind spot of the host vehicle driver, a method of improving the perceived zone of coverage response automotive radar comprising the steps of" (Claim 1)

Plaintiff's Proposal	Defendant's Proposal	Court's Construction
Plain and ordinary meaning. To the extent a construction is necessary, Plaintiff proposes that the preamble is limiting.	<u>Kia, Mazda, Nissan, Jaguar, Mercedes, Porsche, BMW:</u> The preamble is limiting. <u>Honda:</u> Preamble does not limit claim to radar.	The preamble is limiting, and limits the claim to radar.

The parties agree that the preamble of claim 1 is limiting, except that Honda proposes that the preamble does not limit the claim to radar. Plaintiff argues that the preamble is limiting because it defines the subject matter of the claim and "provides antecedent basis" for the terms "host vehicle," "target vehicle," and "zone of coverage" within the claim. Further, Plaintiff argues that the preamble is limiting as a whole, even if the term "radar" does not appear later in the claim.

Defendants agree with Plaintiff that the antecedent basis for "zone of coverage" comes from the preamble, and also argue the preamble "is necessary to give life, meaning, and vitality' to the claim." *Jt. Br., Dkt. 53 at 16* (quoting *Pitney Bowes, Inc. v. Hewlett-Packard Co.*, 182 F.3d 1298, 1305 (Fed. Cir. 1999)).

Honda argues that the preamble should not limit the claim to radar. The premise for its position is that the term only appears in the preamble and not in the body of the claim, and "mere recital of the term in the preamble is insufficient to overcome the presumption that it does not limit the claim." *Id.* (citing *Allen Eng'g Corp. v. Bartell Indus., Inc.*, 299 F.3d 1336, 1346 (Fed. Cir. 2002)).

Other than the issue raised by Honda, all parties agree that the preamble is limiting. The Court agrees and so holds. Therefore, the following discussion only addresses the specific issue raised by Honda -- whether the preamble limits the claim to radar.

a. *The Language of the Claim*

Claim 1 is the '927 Patent's only independent claim. The preamble of claim 1 is: "In a radar system wherein a host vehicle uses radar to detect a target vehicle in a blind spot of the host vehicle driver, a method of improving the perceived zone of coverage response of automotive radar comprising the steps of : . . ." '927 Patent at 5:28-31. The body of the claim recites those steps, which are: "determining the relative speed of the host and target vehicles; selecting a variable sustain time as a function of relative vehicle speed; detecting target vehicle presence and producing an alert command; activating an alert signal in response to the alert command; at the end of the alert command, determining whether the alert signal was active for a threshold time; and if the alert signal was active for

UNITED STATES DISTRICT COURT
CENTRAL DISTRICT OF CALIFORNIA

CIVIL MINUTES – GENERAL

Case No. LA CV14-02454 JAK (JEMx) -- AND RELATED CASES

Date April 17, 2015

Title Signal IP v. American Honda Motor Co., Inc. -- AND RELATED CASES

the threshold time, sustaining the alert signal for the variable sustain time, wherein the zone of coverage appears to increase according to the variable sustain time.” *Id.* at 5:32-6:2.

“Generally, the preamble does not limit the claims.” *Allen Eng’g*, 299 at 1346; *Catalina Mktg. Int’l, Inc. v. Coolsavings.com, Inc.*, 289 F.3d 801, 808 (Fed. Cir. 2002). The preamble “limits the invention if it recites essential structure or steps, or if it is ‘necessary to give life, meaning, and vitality’ to the claim.” *Catalina*, 289 F.3d at 808 (internal citation omitted).

Here, the preamble describes several structural components of the claimed system: “radar system,” “host vehicle,” “target vehicle,” and “automotive radar.” ‘927 Patent at 5:28-31. The rest of the claim describes the steps to be carried out in “a radar system wherein a host vehicle uses radar to detect a target vehicle in a blind spot of the host vehicle driver.” *Id.* at 5:28-30. Nothing in the claim suggests that the steps could be carried out in a non-radar system. This suggests that the recitation of radar in the preamble “recites essential structure or steps.” *Catalina*, 289 F.3d at 808. Because it would otherwise be unclear how information about the target vehicle could be detected and its relative speed measured, the recitation of radar in the preamble gives “life, meaning, and vitality to the claim.” *Id.* Thus, the language of the claim suggests that the preamble’s recitation of radar is limiting.

b. The Specification

Determining whether a preamble is limiting is “resolved only on review of the entirety of the patent to gain an understanding of what the inventors actually invented and intended to encompass by the claim.” *Corning Glass Works v. Sumitomo Elec. U.S.A., Inc.*, 868 F.2d 1251, 1257 (Fed. Cir. 1989).

The specification makes numerous references to “side detection radar” and “coverage,” and further states that the “invention relates to the control of side detection automotive radar systems and particularly to a method of controlling an alarm or alert indication to enhance the perceived coverage of a blind spot.” ‘927 Patent at Abstract, 1:7-10, 2:9-10, 2:62-63. The ‘927 Patent repeatedly refers to the “invention” embodying “radar,” further suggesting that use of radar “is necessary to give life, meaning, and vitality to the claim.” *Pitney Bowes*, 182 F.3d 1298.

c. The Prosecution History

“[C]lear reliance on the preamble during prosecution to distinguish the claimed invention from prior art transforms the preamble into a claim limitation because such reliance indicates use of the preamble to define, in part, the claimed invention.” *Catalina*, 289 F.3d at 808-09. The converse can also be true -- if neither the claim language nor the “prosecution history suggests that the preamble language was considered necessary to the patentability of the claims. . . . this court has found the preamble language not to be limiting.” *Aspex Eyewear, Inc. v. Marchon Eyewear, Inc.*, 672 F.3d 1335, 1347 (Fed. Cir. 2012).

Honda argues that “Signal does not point to anything in the prosecution history of the ‘927 patent that suggests that the term ‘radar’ is limiting.” *Jt. Br.*, Dkt. 53 at 17 (citing *Aspex*, 672 F.3d at 1347).

UNITED STATES DISTRICT COURT
CENTRAL DISTRICT OF CALIFORNIA

CIVIL MINUTES – GENERAL

Case No. LA CV14-02454 JAK (JEMx) -- AND RELATED CASES

Date April 17, 2015

Title Signal IP v. American Honda Motor Co., Inc. -- AND RELATED CASES

However, the file history that has been submitted includes a portion highlighted by Defendants⁴ stating that the primary reason for allowance was that “[t]he prior art cited herein fails to disclose a method of improving the perceived zone of coverage response of automotive radar. . . .” July 22, 1997 Office Action at 2, SIG000001332. This key feature is only found in the preamble, providing another strong indication that its mention of radar is limiting.

d. The Extrinsic Evidence

The extrinsic evidence does not bear on this question.

e. Conclusion

For the reasons discussed above, the preamble is limiting, and limits the claim to radar.

Term No. 2: “Variable Sustain Time” (Claims 1 and 2)

Plaintiff’s Proposal	Defendants’ Proposal	Court’s Construction
Plain and ordinary meaning. To the extent a construction is necessary, Plaintiff proposes: “A variable period of time for which the alert signal persists.”	<u>Honda, Jaguar, Kia, Mazda, Mercedes, Nissan, Porsche, BMW</u> : “a variable period of time for which the alert signal persists after a target vehicle is no longer detected and the alert signal was active for a time equal to or greater than the threshold time”	“A variable period of time for which the alert signal persists”

The Parties agree that “variable sustain time” refers to “a variable period of time for which the alert signal persists.” Defendants contend it must also include the limitations that the signal persists “after a target vehicle is no longer detected and the alert signal was active” for longer than the threshold time.

Defendants argue that the claims and specification support their proposed construction because the patentee identified the “variable sustain time” as more than a preferred embodiment. They argue that the patentee did so by consistently identifying the “variable sustain time” in connection with the signal persisting after the alert signal has been active for at least the threshold time. Jt. Br., Dkt. 53 at 18-19. Defendants contend that the Abstract and Summary refer to the “variable sustain time” as “the invention.” Defendants argue that their proposed construction provides an important clarification between “variable sustain times” and “hold times,” without which “the jury could be easily confused by these similar concepts.” *Id.*

Plaintiff contends that “an alert signal does not need to persist ‘relative to something,’”; it may persist for a number of reasons and should not be limited to just “after a target vehicle is no longer detected.” *Id.* at 24. In particular, Plaintiff argues that weak signals, such as from wheel wells, can be returned to the

⁴ Per S.P.R. 3.5.2, Defendants have flagged this passage as relevant.

UNITED STATES DISTRICT COURT
CENTRAL DISTRICT OF CALIFORNIA

CIVIL MINUTES – GENERAL

Case No. LA CV14-02454 JAK (JEMx) -- AND RELATED CASES

Date April 17, 2015

Title Signal IP v. American Honda Motor Co., Inc. -- AND RELATED CASES

radar detector, and that it is a disclosed purpose of the sustain time to fill in gaps from such “weak” signal returns. *Id.* (citing *SanDisk Corp v. Memorex Prods., Inc.*, 415 F.3d 1278, 1285 (Fed. Cir. 2005) (“[a] claim construction that excludes a preferred embodiment . . . is rarely, if ever, correct.”)). Further, Plaintiff argues that Defendants’ proposed requirement that the alert signal must be active for greater than the threshold time is “superfluous” and reads in “a limitation that simply does not exist.” *Id.* at 25. As to jury confusion, Plaintiff argues that there would be no confusion over “hold time” because, *inter alia*, that term is not present in the asserted claims. *Id.*

In response, Defendants argue that wheel well dropouts are not a discrete embodiment of the variable sustain time because “[t]he ‘927 patent describes a binary system based simply on whether the reflected signal is above or below a threshold,” and that when there is a wheel well dropout, “the ‘927 patent expressly identifies this low reflectivity . . . as an example of the vehicle no longer being detected.” *Id.* at 22 (emphasis omitted).

a. *The Language of the Claims*

Claim 1 recites a radar system for improving blind spot coverage, one of the steps being “selecting a variable sustain time as a function of relative vehicle speed.” *Id.* at 5:34-35. The system then determines “whether the alert signal was active for a threshold time.” If it does so, the alert signal is “sustain[ed] . . . for the variable sustain time.” *Id.* at 5:41-44. Thus, the “zone of coverage appears to increase according to the variable sustain time.” *Id.* at 6:1-2. Claim 2, which depends from claim 1, is: “The invention as defined in claim 1 wherein the variable sustain time is an inverse function of the relative vehicle speed.” *Id.* at 6:3-5.

The claims do not explicitly require the target vehicle to be “no longer detected.” And, there is no implicit requirement in the claims that “variable sustain time” be limited to triggering “after a target vehicle is no longer detected.” For these reasons, the words of the claims do not exclude, for example, a variable sustain time that begins during a period of detection, which is not necessarily a practical system design solution to the problem of delay in receiving and processing the real-time radar data.

The claims separately recite the threshold time requirement. Therefore, it is not necessary to import or restate this limitation onto the term “variable sustain time” to provide clarity. “Claim construction is a matter of resolution of disputed meanings and technical scope, to clarify and when necessary to explain what the patentee covered by the claims, for use in the determination of infringement. It is not an obligatory exercise in redundancy.” *U.S. Surgical Corp. v. Ethicon, Inc.*, 103 F.3d 1554, 1568 (Fed. Cir. 1997).

b. *The Specification*

The specification teaches that the invention is designed to address several problems common in vehicle radar detection systems: (1) “false alarms” from sources such as “guard rails, walls, or other stationary objects”; (2) “alert dropout” caused by “variable reflectivity of a target vehicle” such as a weak signal from a vehicle wheel well; and (3) “alert signal flicker” caused “when a distributed target just enters or just clears a detection zone,” which may cause “the alert to oscillate in an annoying manner.” ‘927 Patent at 1:39-2:6.

UNITED STATES DISTRICT COURT
CENTRAL DISTRICT OF CALIFORNIA

CIVIL MINUTES – GENERAL

Case No. LA CV14-02454 JAK (JEMx) -- AND RELATED CASES

Date April 17, 2015

Title Signal IP v. American Honda Motor Co., Inc. -- AND RELATED CASES

In the invention, the time the alert signal has been active is “compared to a threshold” time, which “can either be fixed or vary inversely with host vehicle speed.” *Id.* at 2:16-18. If the alert time is less than the threshold, the signal is held for “a minimal hold time,” which may be fixed or a function of vehicle speed. *Id.* at 2:18-21. If the alert time is greater than or equal to the threshold, it is sustained for a longer period which “varies according to the absolute value of the relative velocity between the target and host vehicles.” *Id.* at 2:25-33. This is the variable sustain time.

The algorithm for sustaining the alert signal is shown in Figure 5 of the ‘927 Patent, which is reproduced below, with annotations added. *Id.* at 4:22-42. This figure shows that the variable sustain time is triggered when alert devices have been active for at least the threshold time.

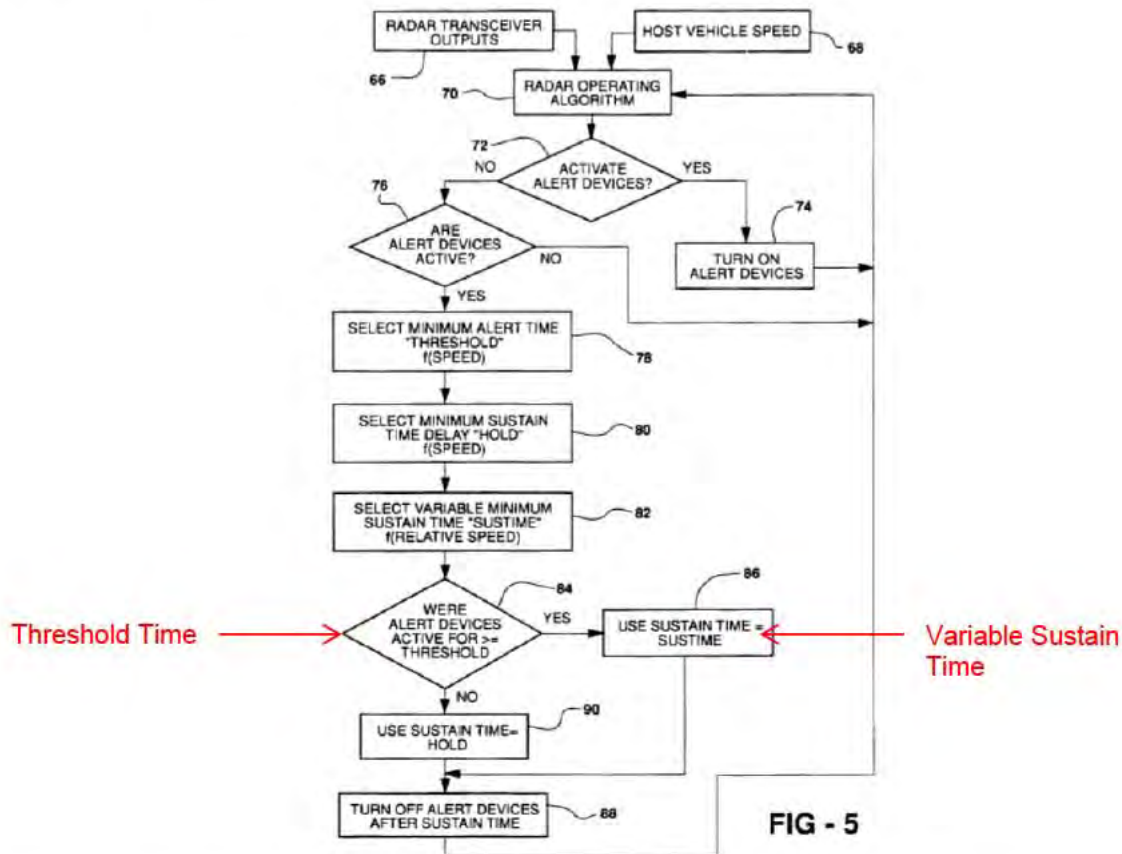

The variable sustain time is used to delay the time an alert signal is sounded where the alert has been sounding for longer than a certain threshold time. Otherwise the alert time is delayed by a different “HOLD” time. *Id.* at 4:36-49.

UNITED STATES DISTRICT COURT
CENTRAL DISTRICT OF CALIFORNIA

CIVIL MINUTES – GENERAL

Case No. LA CV14-02454 JAK (JEMx) -- AND RELATED CASES

Date April 17, 2015

Title Signal IP v. American Honda Motor Co., Inc. -- AND RELATED CASES

Defendants argue that the variable sustain time must be “added to extend the alert signal after the vehicle is no longer detected,” quoting several passages in the specification. Jt. Br., Dkt. 53 at 21-22. None of these supports their conclusion. The specification shows that an alert is turned on when a vehicle is detected,⁵ that the sustain time is “used to delay alert turn off,” ‘927 Patent at 4:42-43, that “a variable sustain time is added to each alert signal which exceeds a threshold value,” *id.* at Abstract, and “[w]hen the alert time is equal to or greater than the threshold, a longer sustain time is applied to hold the signal on.” *id.* at 2:25-28. All of the foregoing could remain true even if the variable sustain time were added to extend the alert system while the vehicle is still detected. As noted above, some period of overlap may or may not be necessary for practical reasons. Nothing else in the specification requires that the variable sustain time be used only when a vehicle is no longer detected. Thus, the specification supports Plaintiff’s argument that the alert signal “does not need to persist ‘relative to something,’ because it simply persists until it stops.” Jt. Br., Dkt. 53 at 24.

Plaintiff further argues that the “purpose of the sustain time is to fill in gaps or dropout events due to ‘weak’ return signals and ‘weak’ field of strength portions of the radar signal.” *Id.* (citing ‘927 Patent at 3:52-61). Defendant contends “there is no such embodiment” in the specification because “[t]he ‘927 patent describes a binary system based simply on whether the reflected signal is above or below a threshold.” *Id.* at 22. According to Defendants, Figure 3 of the ‘927 Patent “expressly identifies . . . low reflectivity . . . as an example of the vehicle no longer being detected.” *Id.* As to this issue each of the Parties is correct, in part. Plaintiff correctly notes that in Figure 3a, which is reproduced below with annotations added, the detected signal from wheel wells is weak, but nonzero. But Defendants are correct that this is then converted into a binary output for transmission, as shown in Figure 3c, which is also below.

⁵ The alert is issued based on a “target discrimination program,” ‘927 Patent at 4:28-32, which is described in U.S. Pat. No. 5,530,447 (incorporated by reference). This patent claims a method for “discriminating a target which presents a hazard to the vehicle,” where a “target is hazardous if the sum of the measured vehicle velocity and the estimated parallel target velocity is greater than a first predetermined threshold.” ‘447 Patent Claim 1.

UNITED STATES DISTRICT COURT
CENTRAL DISTRICT OF CALIFORNIA

CIVIL MINUTES – GENERAL

Case No. LA CV14-02454 JAK (JEMx) -- AND RELATED CASES

Date April 17, 2015

Title Signal IP v. American Honda Motor Co., Inc. -- AND RELATED CASES

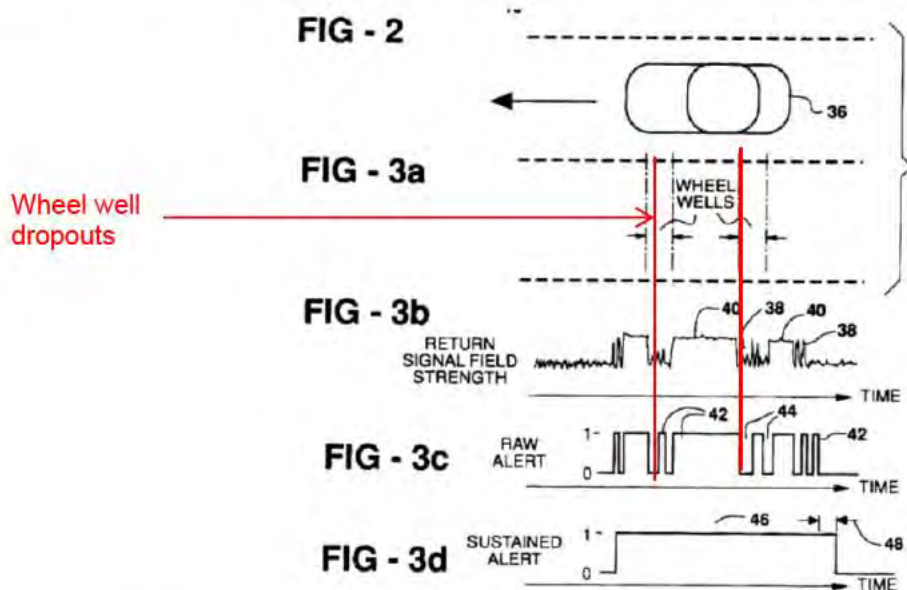

Ultimately, this dispute is not material because the variable alert time functions in precisely the same manner for wheel well dropouts as it does for extending the zone of coverage as illustrated in Figure 4.

c. The Prosecution History

The prosecution history does not bear on this question.

d. The Extrinsic Evidence

The extrinsic evidence does not bear on this question.

e. Conclusion

For the reasons outlined above, the claim is construed to mean: "A variable period of time for which the alert signal persists."

UNITED STATES DISTRICT COURT
CENTRAL DISTRICT OF CALIFORNIA

CIVIL MINUTES – GENERAL

Case No. LA CV14-02454 JAK (JEMx) -- AND RELATED CASES

Date April 17, 2015

Title Signal IP v. American Honda Motor Co., Inc. -- AND RELATED CASES

Term No. 3: “Wherein the Zone of Coverage Appears to Increase According to the Variable Sustain Time” / “Improving the Perceived Zone of Coverage” (Claim 1)

Plaintiff's Proposal	Defendant's Proposal	Court's Construction
<p>Not indefinite</p> <p>Plain and ordinary meaning.</p> <p>To the extent a recitation of the plain and ordinary meaning is necessary, Plaintiff proposes:</p> <p>“wherein the zone of coverage as perceived by the vehicle driver appears to increase according to a variable sustain time.” (for “wherein the zone of coverage appears to increase . . .) and</p> <p>“improving the perceived zone of coverage, compared to an interrupted signal” (for “improving the perceived zone of coverage”)</p>	<p><u>Honda, Mazda, Nissan, Jaguar, Mercedes, Porsche, VW/Bentley:</u></p> <p>Indefinite</p> <p><u>Honda:</u> Alternatively, “wherein the alert signal remains active when a target vehicle is beyond the range that the object detection system can detect”</p>	<p>Not indefinite</p> <p>“wherein the alert signal remains active when a target vehicle is beyond the range that the object detection system can detect”</p>

The Parties agree that the zone of coverage appears to increase / improve from the perspective of the driver of the host vehicle. Defendants Honda, Mazda, Nissan, Jaguar, Mercedes, and Porsche contend the term is indefinite because “it would ‘depend solely on the unrestrained, subjective opinion of a particular individual purportedly practicing the invention.’” Jt. Br., Dkt. 53 at 26.

Defendants argue that the specification and prosecution history provide no guidance for an “objective standard defining what an individual must observe in order for it to ‘appear’ that the zone of coverage increases according to the variable sustain time.”⁶ *Id.* (citing *Datamize LLC v. Plumtree Software, Inc.*, 417 F.3d 1342, 1350-51 (Fed. Cir. 2005) (“aesthetically pleasing” found indefinite); *Interval Licensing LLC v. AOL, Inc.*, 766 F.3d 1370-71 (“unobtrusive manner” found indefinite); *Prolifiq Software Inc. v. Veeva Sys. Inc.*, No. C 13-03644 SI, 2014 WL 3870016, at *8 n.6 (N.D. Cal. Aug. 6, 2014) (“differently versioned” found indefinite)).

⁶ Defendants’ expert has opined that the term is also ambiguous because it is not clear whether the zone of coverage appears to increase to the driver or to the system designer. Eskandarian Decl. ¶ 24, JA-0057. Defendants have not expressly advanced this argument, and agree that the zone of coverage appears to increase from the driver’s perspective. Defendants VW/Bentley note their position that the indefiniteness analysis does not require consideration of expert opinion.

UNITED STATES DISTRICT COURT
CENTRAL DISTRICT OF CALIFORNIA

CIVIL MINUTES – GENERAL

Case No. LA CV14-02454 JAK (JEMx) -- AND RELATED CASES

Date April 17, 2015

Title Signal IP v. American Honda Motor Co., Inc. -- AND RELATED CASES

Honda provides an alternative construction in the event “wherein the zone of coverage” is not found indefinite. It adds the requirement that the alert system “remains active when a target vehicle is beyond the range that the object detection system can detect.” *Id.* at 32.

Plaintiff argues that Defendants’ cases are distinguishable because: (1) they involve subjective criteria; and (2) more pertinently, the Federal Circuit has upheld terms with a similar user-perception component -- “color perceptible to an observer or observers utilizing a night vision aid” -- as not indefinite when the “fundamental purpose of the invention [was] to permit displays that convey information . . . to crewmembers . . . without such light overwhelming sensor elements.” *Id.* at 38 (quoting *Honeywell Int’l, Inc. v. United States*, 609 F.3d 1292, 1302 (Fed. Cir. 2010)).

According to Plaintiff, the zone of coverage is increased when the alert signal is uninterrupted rather than interrupted. *Id.* at 35. Plaintiff’s expert, Dr. Ioannou, opines that “drivers cannot reasonably differ” in their perception of whether a signal is interrupted or uninterrupted. Ioannou Decl. ¶ 24, JA-0206. In the event construction is necessary, Plaintiff proposes adding “by the vehicle driver” to clarify to whom the increased zone of coverage is perceived (for “wherein the zone of coverage . . .”) and adding “compared to an interrupted signal” to give direction regarding what the zone of coverage refers to (for “improving . . .”). Jt. Br., Dkt. 53 at 34-35.

a. *The Language of the Claim*

The relevant portions of claim 1 are: “a method of improving the perceived zone of coverage response of automotive radar,” and “sustaining the alert signal for the variable sustain time, wherein the zone of coverage appears to increase according to the variable sustain time.” ‘927 Patent at 5:30-31, 5:44-6:2. The preamble describes a radar system that detects a target vehicle “in a blind spot of the host vehicle driver.” *Id.* at 5:29-30.

From the claim alone, it is not clear whether the “perceived zone of coverage” is a visible area, an uninterrupted signal or something else. The claim does indicate that the zone of coverage is related to “a blind spot of the host vehicle driver,” suggesting that the zone of coverage increases from the driver’s perspective. *Id.*

b. *The Specification*

It is “an object of the invention to improve the zone of coverage response of side detection radar.” *Id.* at 2:9-10. The invention accomplishes this by delaying the alert signal turn-off which “improves the zone of coverage as perceived by the vehicle driver.” *Id.* at 2:15-34. Therefore, the specification makes clear that the zone of coverage improves from the driver’s perspective.

The parties disagree whether the “zone of coverage” is represented by a physical area or an uninterrupted alert signal. Figure 4, which is reproduced below, shows “actual zones and perceived extensions of radar coverage according to the invention,” *id.* at 2:50-52, while the specification distinguishes the “zone of coverage” from an uninterrupted signal. Figures 3c and 3d, which are reproduced below, illustrate that “gaps 44 are removed and any remaining gaps 44 are minimized by this method. . . . At the same time, because of the sustaining effect, the sustained alert signal 46 is

UNITED STATES DISTRICT COURT
CENTRAL DISTRICT OF CALIFORNIA

CIVIL MINUTES – GENERAL

Case No.	LA CV14-02454 JAK (JEMx) -- AND RELATED CASES	Date	April 17, 2015
Title	Signal IP v. American Honda Motor Co., Inc. -- AND RELATED CASES		

longer by a period 48 than the alert command, thereby extending the zone of coverage as perceived by the driver.” *Id.* at 4:1-7. Thus, the same invention, operating the same way, can be described as solving two different problems -- eliminating gaps, and extending the zone of coverage.

For these reasons, the specification distinguishes between “filling in gaps in alert signals to produce . . . a steady alert signal while a target is in view of the radar” and “increas[ing] the perceived zone of coverage by extending the length of the alert signal.” *Id.* at 5:19-25. The specification consistently refers to the zone of coverage extension as extensions at the beginning and end (box 64 in Figure 4), not gap-filling (Figures 3c vs. 3d).

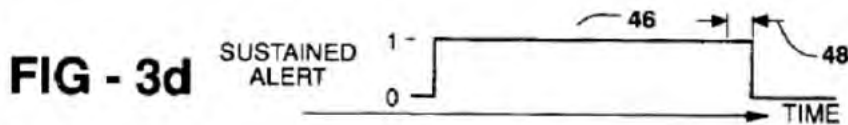
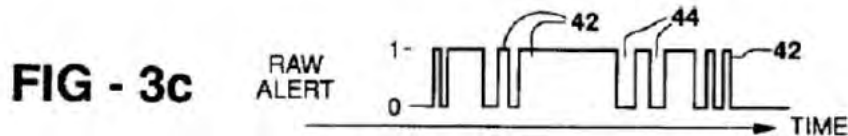
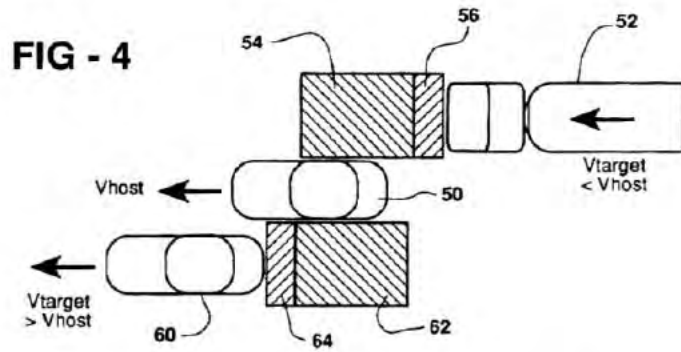

As to the use of the terms “perceived” and “appears” in the claim, nothing in the specification requires that a driver actually notice an increase in the zone of coverage. The specification explains that the “zone actually monitored by radar is supplemented by a zone extension 64 due to the sustain period 48.” *Id.* at 4:9-15. In short, the “perceived” increase in the zone simply means that the alert remains on past the time that the radar system is actually receiving a return signal, which indicates the presence of an object, at or above the level needed to turn the alert on according to the system logic. Thus, the driver does not, as Defendants contend, need to “observe the size of an invisible warning area around the vehicle.” *Jt. Br.*, Dkt. 53 at 27. Nor does a driver need to be able to make comparisons between vehicles with or without the system. The perceived extension is objectively measurable, but the driver

UNITED STATES DISTRICT COURT
CENTRAL DISTRICT OF CALIFORNIA

CIVIL MINUTES – GENERAL

Case No. LA CV14-02454 JAK (JEMx) -- AND RELATED CASES

Date April 17, 2015

Title Signal IP v. American Honda Motor Co., Inc. -- AND RELATED CASES

need not measure it. The term “perceived” simply refers to the fact that the radar system coverage is not actually extended, but the alert stays on as if it were.

If the term is not indefinite, Honda and Plaintiff propose constructions. For “wherein the zone of coverage . . .” Honda argues that the perceived zone of coverage can only increase when the target vehicle is not actually detected. *Jt. Br.*, Dkt. 53 at 32-33, quoting ‘927 Patent at 4:18-20. (The “zone 62 actually monitored by radar is supplemented by a zone extension 64 due to a sustain period 48.”) Plaintiff argues that Honda’s proposed construction is too narrow because “the purpose of the sustain time is to fill in gaps or dropout events due to ‘weak’ return signals and ‘weak’ field strength portions of the radar signal.” *Id.* at 40. Plaintiff argues that, although the specification distinguishes between gap-filling and the zone of coverage increase, the claim itself does not separately describe reduced signals or dropouts. From this, Plaintiff argues that if the claim were limited to “when a target vehicle is beyond the range that the object detection system can detect,” it would exclude a preferred embodiment. *Id.* (citing *SanDisk Corp. v. Memorex Prods., Inc.*, 415 F.3d 1278, 1285 (Fed. Cir. 2005) (“A claim construction that excludes a preferred embodiment . . . is rarely, if ever, correct”). Given that all claims depend from claim 1, Plaintiff argues that Honda’s proposed construction would exclude a preferred embodiment.

For the construction of “wherein the zone of coverage,” Plaintiff proposes adding “as perceived by the vehicle driver” to account for any confusion as to who perceives an apparent increase in the zone of coverage. *Id.* at 25, 35. The parties agree that the zone of coverage increases from the driver’s perspective. However, importing this limitation is unnecessary and suggests a subjective component that is not required by the claims.

For “improving the perceived zone of coverage,” Plaintiff proposes adding, “compared to an interrupted signal.” *Id.* at 48. However, for the reasons described in this section, the specification clearly associates improvements in “zone of coverage” with extensions at the beginning and the end of the signal, not filling gaps due to weak reflections. For these reasons, this proposed addition to the construction is not appropriate.

c. The Prosecution History

The prosecution history does not bear on this question.

d. The Extrinsic Evidence

Each party contends that Ioannou’s deposition testimony supports its arguments.⁷ Ioannou opined that “it is not possible for a human to be able” to measure small fluctuations in the zone of coverage while

⁷ VW/Bentley argue that the indefiniteness decision “should be based on the intrinsic evidence alone,” disregarding the Ioannou declaration and deposition. Experts “may be examined to explain terms of art . . . but they cannot be used to prove ‘the proper or legal construction of any instrument of writing.’” *Teva Pharm. USA Inc. v. Sandoz, Inc.*, 135 S. Ct. 831, 840 (2015) (quoting *Winans v. New York & Erie R. Co.*, 21 How. 88, 100-101 (1859); also citing *Prolifiq*, 2014 WL 83700016 at *8 n. 6). According to VW/Bentley, Ioannou does not explain terms of art, but “merely proposes his own claim construction based on his analysis of the intrinsic evidence.” Plaintiff argues that Ioannou’s opinion should be considered because the “definiteness inquiry trains on the

UNITED STATES DISTRICT COURT
CENTRAL DISTRICT OF CALIFORNIA

CIVIL MINUTES – GENERAL

Case No. LA CV14-02454 JAK (JEMx) -- AND RELATED CASES

Date April 17, 2015

Title Signal IP v. American Honda Motor Co., Inc. -- AND RELATED CASES

driving. Ioannou Depo. at 76:1-11, JA-0029. Defendants interpret this testimony to mean that “Dr. Ioannou believes that a driver neither knows, nor cares, about the length of the sustain time or the size of the zone of coverage.” Jt. Br., Dkt. 53 at 28. Plaintiff responds that Ioannou’s testimony actually shows how “every single driver will see an improvement.” Ioannou Depo. at 71:22-23, JA-0028.

According to Ioannou, the proper measurement for the “perceived zone of coverage” is the increase in coverage “compared to not having the invention.” *Id.* at JA-0019, 35:14-18. Without the invention, there will be gaps or a shorter zone of coverage. The invention eliminates these problems, clearly increasing the zone of coverage. Ioannou explains that a driver “doesn’t read the radar” but rather perceives the zone of coverage as “the light or a sound” issued by the warning system. *Id.* at 34:16-24, JA-0019. In comparison, without the invention, “an increase . . . will be clear to the driver.” *Id.* at 59:3-15, JA-0025. Thus, “every single driver will see an improvement.” *Id.* at 71:22-23, JA-0028. These portions of Ioannou’s testimony support the perceived increase being noticeable although not necessarily subjective.

Ioannou also testifies that drivers have “different perceptions”: “Some of them which are technically advanced may say . . . that’s a sensor here that goes on and off. . . . Others will ignore it.” *Id.* at 42:18-24, JA-0021. Ioannou explicitly said that often, the “driver doesn’t know” that the zone has been extended, *id.* at 54:13-15, JA-0024, because “[t]he driver is not going to count the seconds that the alert signal was on Some of this extension is going into the millisecond area.” *Id.* at 74:3-16, JA-0029.

Ioannou ultimately explains that “[t]hey designed it in order to make sure that if there is a vehicle there and it’s just moving out and the radar didn’t see it [t]hey want to say the guy is still there.” *Id.* at 54:15-21, JA-0024. Thus, the claim term merely requires there to be a warning signal at times that, absent the invention, it would otherwise not be on. The claim does not require the driver actually to notice the details of the improvement. Thus, Ioannou’s testimony supports the conclusion that this term is adequately definite.

e. *Conclusion*

For the reasons described above, the terms are not indefinite. For the terms “wherein the zone of coverage appears to increase according to the variable sustain time” and “improving the perceived zone of coverage,” the Court adopts Honda’s construction: “wherein the alert signal remains active when a target vehicle is beyond the range that the object detection system can detect.”

Term No. 4: “A Threshold Time” (Claim 1)

understanding of a skilled artisan at the time of the patent application.” *Nautilus*, 134 S. Ct. at 2129, n.10. Because the Ioannou testimony is helpful in explaining a skilled artisan’s understanding of alert signals, it is considered in this Order.

UNITED STATES DISTRICT COURT
CENTRAL DISTRICT OF CALIFORNIA

CIVIL MINUTES – GENERAL

Case No. LA CV14-02454 JAK (JEMx) -- AND RELATED CASES

Date April 17, 2015

Title Signal IP v. American Honda Motor Co., Inc. -- AND RELATED CASES

On March 26, 2015, the Parties agreed to construct “a threshold time” as “length of time that the alert signal must be active for the alert signal to be sustained for the variable sustain time.” Notice of Agreed Construction as to Claim Term “Threshold Time” in U.S. Patent No. 5,714,927, Dkt. 55.

Term No. 5: “Improving the Perceived Zone of Coverage” (Claim 1)

Plaintiff’s Proposal	Defendant’s Proposal	Court’s Construction
<p>Not indefinite</p> <p>Plain and ordinary meaning.</p> <p>To the extent a construction is necessary, Plaintiff proposes: “Improving the perceived zone of coverage, compared to an interrupted signal.”</p>	<p>Honda, Mazda, Nissan, Jaguar, Mercedes, Porsche, and VW/Bentley:</p> <p>Indefinite under § 112, paragraph 2</p>	<p>Not indefinite</p> <p>“wherein the alert signal remains active when a target vehicle is beyond the range that the object detection system can detect”</p>

Due to the similarity of the terms and arguments, the same conclusions apply to this term and term no. 3, above, i.e., “wherein the zone of coverage appears to increase according to the variable sustain time.”

For these reasons, the term is not indefinite. As previously stated, Plaintiff’s addition of “compared to an interrupted signal” is not appropriate in light of the specification’s clear association of improvements in the zone of coverage, with extensions at the beginning and end of the signal, and not specifically with filling gaps due to weak reflections.

Finally, the intrinsic and extrinsic evidence support the conclusion that claim 1 merely requires a warning signal that would otherwise not be present but for the invention. The claim does not require a driver’s subjective perception of increased coverage. Therefore, the following construction is adopted: “improving the perceived zone of coverage” means “wherein the alert signal remains active when a target vehicle is beyond the range that the object detection system can detect.”

B. The ‘375 Patent⁸

The ‘375 Patent was issued on March 24, 1998 to assignee Delco. The ‘375 Patent discloses a method of inhibiting or allowing airbag deployment using an array of pressure sensors on a vehicle passenger seat. ‘375 Patent at Abstract. The parties request construction of six terms, one of which VW and Bentley argue is indefinite.

The ‘375 Patent teaches that the passenger seat of a vehicle may be occupied or unoccupied, and may be occupied by a child in an infant seat. ‘375 Patent at 1:18-20, 44-47. In the latter case, the infant seat

⁸ The ‘375 Patent is provided as Exhibit G, JA-0261-69.

UNITED STATES DISTRICT COURT
CENTRAL DISTRICT OF CALIFORNIA

CIVIL MINUTES – GENERAL

Case No. LA CV14-02454 JAK (JEMx) -- AND RELATED CASES

Date April 17, 2015

Title Signal IP v. American Honda Motor Co., Inc. -- AND RELATED CASES

could be in a rear or forward-facing position. *Id.* at 1:18-25. Although airbag deployment is generally preferred if the passenger seat is occupied, if the seat is occupied by a rear-facing infant seat, it is desirable to prevent airbag deployment. *Id.* at 1:28-29. It is also desirable for the system to be sensitive to possible seating positions of small children. *Id.* at 1:49-50. In a disclosed embodiment, the passenger seat is equipped with 12 pressure sensors, arranged on the seat according to Figure 2, which is reproduced below. *Id.* at 3:21-23.

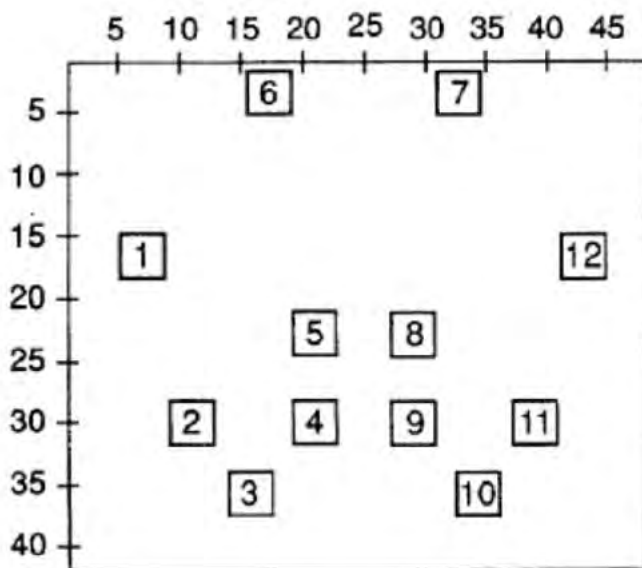

'375 Patent Figure 2 -- Sensor Arrangement

In this embodiment, the sensors are turned on one at a time, a microprocessor samples each sensor four times, and the values are averaged, bias-corrected, and filtered with a time constant. *Id.* at 3:41-43. This resulting value is then used to determine "decision measures," *id.* at 3:48-49, using "fuzzy logic" to rate and handle marginal cases. *Id.* at 2:13, 19-20.

The overall operation is shown in Figure 3 of the '375 patent, which is reproduced below.

UNITED STATES DISTRICT COURT
CENTRAL DISTRICT OF CALIFORNIA

CIVIL MINUTES – GENERAL

Case No. LA CV14-02454 JAK (JEMx) -- AND RELATED CASES

Date April 17, 2015

Title Signal IP v. American Honda Motor Co., Inc. -- AND RELATED CASES

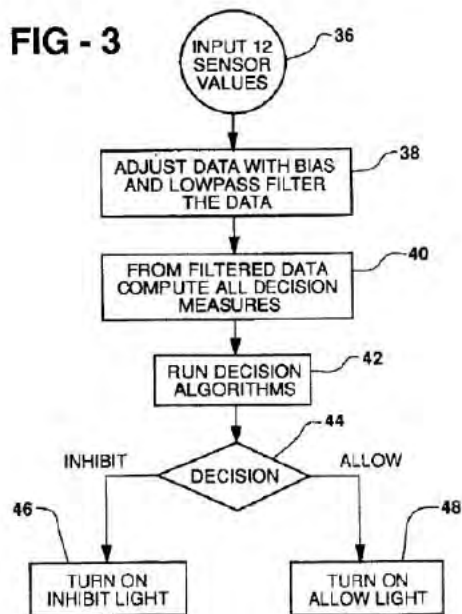

Figure 4 of the '375 Patent, which is reproduced below, shows the decision measure algorithm flow chart. *Id.* at 3:48-51. The sensor values are summed to obtain the total force. *Id.* at 3:49-51. Each sensor is given a "load rating," which tracks whether a given sensor is detecting some load. *Id.* at 4:1-4. The total load rating, which is the sum of the individual load ratings, is then calculated. *Id.* at 4:9-11.

UNITED STATES DISTRICT COURT
CENTRAL DISTRICT OF CALIFORNIA

CIVIL MINUTES – GENERAL

Case No. LA CV14-02454 JAK (JEMx) -- AND RELATED CASES

Date April 17, 2015

Title Signal IP v. American Honda Motor Co., Inc. -- AND RELATED CASES

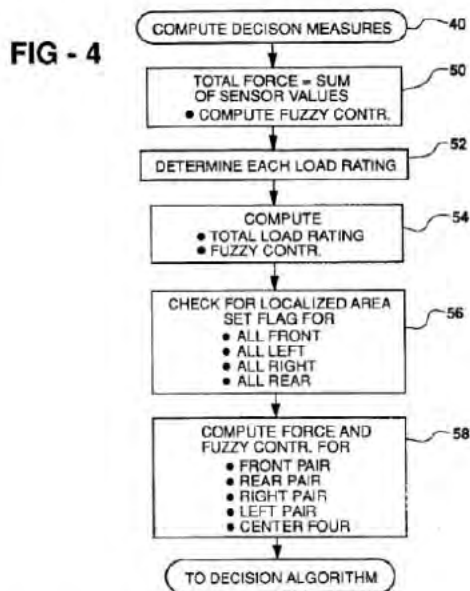

Next, the localized areas, shown in Figure 7, are checked for force concentration. *Id.* at 4:18-19. The sensors are divided into overlapping front, left, right and rear areas, and the algorithm determines whether all of the pressure is concentrated in a particular group. *Id.* at 4:19-25. If so, a flag is set for that group. *Id.* at 4:27-29.

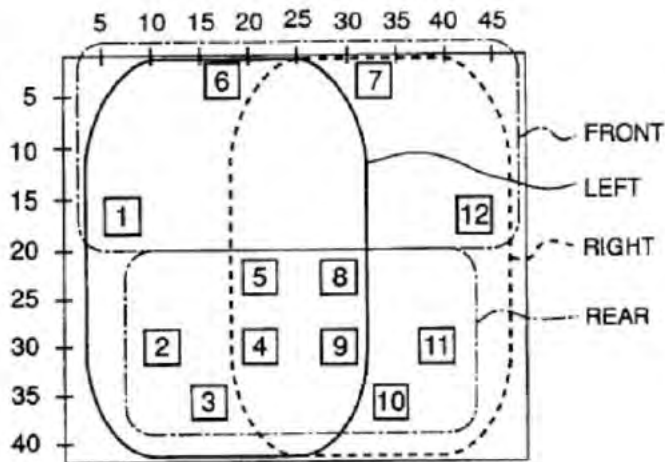

'375 Patent Figure 7 -- Localized Areas

The deployment decision algorithm is shown in Figure 8 of the '375 Patent, which is reproduced below.

UNITED STATES DISTRICT COURT
CENTRAL DISTRICT OF CALIFORNIA

CIVIL MINUTES – GENERAL

Case No. LA CV14-02454 JAK (JEMx) -- AND RELATED CASES

Date April 17, 2015

Title Signal IP v. American Honda Motor Co., Inc. -- AND RELATED CASES

The force is summed for the front two sensors, the rear two sensors, the right two sensors, the left two sensors and the four center sensors. *Id.* at 4:30-31. These values are all sent to a decision algorithm, which determines whether the rails of an infant seat are detected, and if so, whether the seat is facing forward or rearward. *Id.* at 4:65-5:1. The decision algorithm then determines whether to allow or inhibit airbag deployment. Given sufficient force, it checks for the rails of an infant seat. In the case of a forward-facing seat, deployment is allowed; in the case of a rearward-facing seat, deployment is inhibited. *Id.* at 5:4-9.

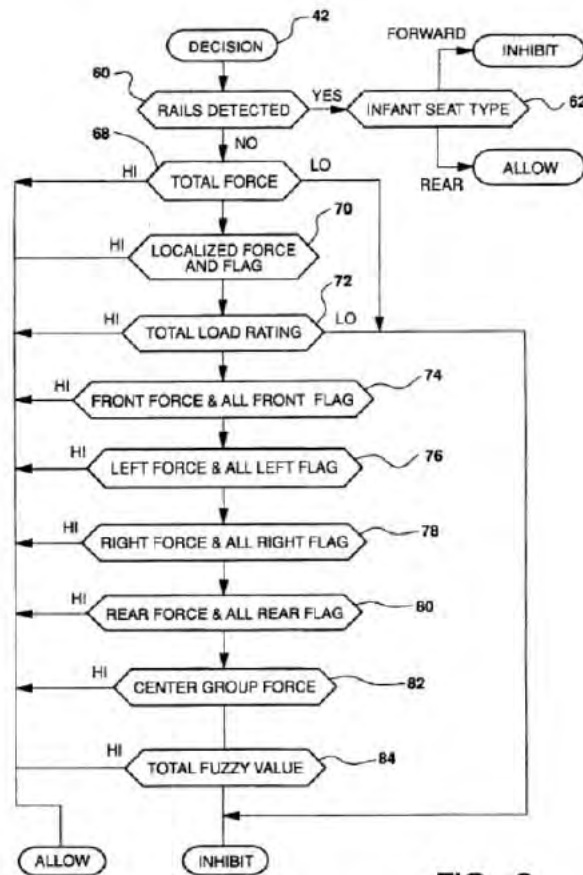

FIG - 8

In the absence of infant seat rails, deployment is allowed if the force is above a certain threshold, and inhibited if it is not. *Id.* at 5:12-15. Deployment is allowed if the total force is above a “high threshold,” or the localized force for a sensor group is “above a threshold and the flag corresponding to that group is set.” *Id.* at 5:12-18.

The disputed terms all occur in ‘375 Patent claim 1, which is reproduced below with the disputed terms in bold. *Id.* at 5:40-59.

UNITED STATES DISTRICT COURT
CENTRAL DISTRICT OF CALIFORNIA

CIVIL MINUTES – GENERAL

Case No. LA CV14-02454 JAK (JEMx) -- AND RELATED CASES

Date April 17, 2015

Title Signal IP v. American Honda Motor Co., Inc. -- AND RELATED CASES

1. A method of airbag control in a vehicle having an **array of force sensors on the passenger seat** coupled to a controller for determining whether to allow airbag deployment based on sensed force and **force distribution** comprising the steps of:

- measuring the force detected by each sensor;
- calculating the total force of the **sensor array**;
- allowing deployment if the total force is above a total threshold force;
- defining a plurality of **seat areas**, at least one sensor located in each **seat area**;
- determining the existence of a local pressure area when the calculated total force **is concentrated** in one of said **seat areas**;
- calculating a local force as the sum of forces sensed by each sensor located in the **seat area** in which the total force is **concentrated**; and
- allowing deployment if the local force is greater than a predefined **seat area threshold force**.

Term No. 6: "Force Distribution" (Claim 1)

Plaintiff's Proposal	Defendant's Proposal	Court's Construction
Plain and ordinary meaning. To the extent a construction is necessary, Plaintiff proposes: "A distribution of force or pressure on the seat."	<u>Honda, Mazda, Mitsubishi, Nissan:</u> "a pattern of pressure distribution measured by sampling a plurality of seat sensors."	None necessary.

The parties agree that "force" means "pressure that is indicative of weight." JCC, Dkt. 46 at 2. Several defendants contend that a "pattern" of pressure distribution is measured. Defendants also argue that the term "sampling" should be used. Jt. Br., Dkt. 53 at 51.

Plaintiff disagrees, arguing that "pattern" recognition is only used for detecting an infant seat, and that "sampling" language would "impose[] a limitation not found in the claims." Further, Plaintiff's proposed construction adds "on the seat" for clarification. *Id.* at 53.

a. *The Language of the Claims*

Claim 1 describes a method "for determining whether to allow airbag deployment based on sensed force and force distribution" using "an array of force sensors on the passenger seat." *Id.* at 5:40-43. The term "force distribution" appears in the preamble of the claim, and the body of the claim expressly recites the steps to be used in determining force distribution. Thus, the force detected by each sensor is measured, the forces are summed, a plurality of seat areas are defined and the concentration of force in one or more of these seat areas is then determined. Nothing in claim 1 refers to a "pattern" of force or pressure distribution, or any "sampling."

Nine claims depend from claim 1. Some of these claims describe using a "pattern." Claim 2 adds the steps of "determining a pattern of sensor loading" and "determining from the pattern of sensor loading

UNITED STATES DISTRICT COURT
CENTRAL DISTRICT OF CALIFORNIA

CIVIL MINUTES – GENERAL

Case No. LA CV14-02454 JAK (JEMx) -- AND RELATED CASES

Date April 17, 2015

Title Signal IP v. American Honda Motor Co., Inc. -- AND RELATED CASES

whether an infant seat is on the passenger seat.” *Id.* at 5:62-64. Claims 3 and 4 further describe the step of determining a pattern of sensor loading. *Id.* at 6:4, 9-10. Claim 6 adds the steps of “determining a pattern of sensor loading” and “prior to the step of allowing deployment if the total force is above a total threshold force, determining from the pattern of sensor loading whether an infant seat is on the seat.” *Id.* at 6:28-32. As used in the claims, “pattern” determinations are separate from the more fundamental steps present in claim 1. Claim 1 mentions neither “patterns” nor “infant seats.” This suggests that the “pattern” limitation should not be imported into claim 1. See *Phillips v. AWH Corp.*, 415 F.3d 1303, 1314-15 (Fed. Cir. 2005) (“[T]he presence of a dependent claim that adds a particular limitation gives rise to a presumption that the limitation in question is not present in the independent claim.”).⁹

Taken as whole, the words of the claims suggest that the “pattern” recited in the dependent claims is not merely the “concentrat[ion]” of claim 1. The claim explains that the force distribution is measured using sensors “on the passenger seat,” in accordance with Plaintiff’s proposed addition. ‘375 Patent at 5:40-41. However, because the claim already expressly states that the sensors are on the seat, it is not necessary to repeat this clarification in the construction of “force distribution.” See *U.S. Surgical Corp. v. Ethicon, Inc.*, 103 F.3d 1554, 1568 (Fed. Cir. 1997).

b. The Specification

The specification explains that “[a] dozen sensors, judicially [sic, likely “judiciously”] located in the seat, can garner sufficient pressure and distribution information to allow determination of the occupant type and infant seat position.” ‘375 Patent at 1:59-61. Figure 8 of the ‘375 Patent, which is reproduced below with annotations added, shows that the infant seat detection and type decisions come before the total and local force decisions. The infant seat decision involves pattern concepts like rails and forward or rear orientation; the local force decisions determine whether the local force meets a threshold value in a given seat area. However, the specification also provides that “pattern recognition for detecting children is made possible by applying fuzzy logic concepts to the pressure reading for each sensor in the array and assigning a load rating to each sensor.” *Id.* at 2:12-15.

⁹ Defendants contend that claims 2 and 6 are not relevant to this question because neither discusses “local” pressures or forces. *Jt. Br.*, Dkt. 53 at 53. This argument is not convincing because both claims depend from claim 1, which does include “local force” limitations.

UNITED STATES DISTRICT COURT
CENTRAL DISTRICT OF CALIFORNIA

CIVIL MINUTES – GENERAL

Case No. LA CV14-02454 JAK (JEMx) -- AND RELATED CASES

Date April 17, 2015

Title Signal IP v. American Honda Motor Co., Inc. -- AND RELATED CASES

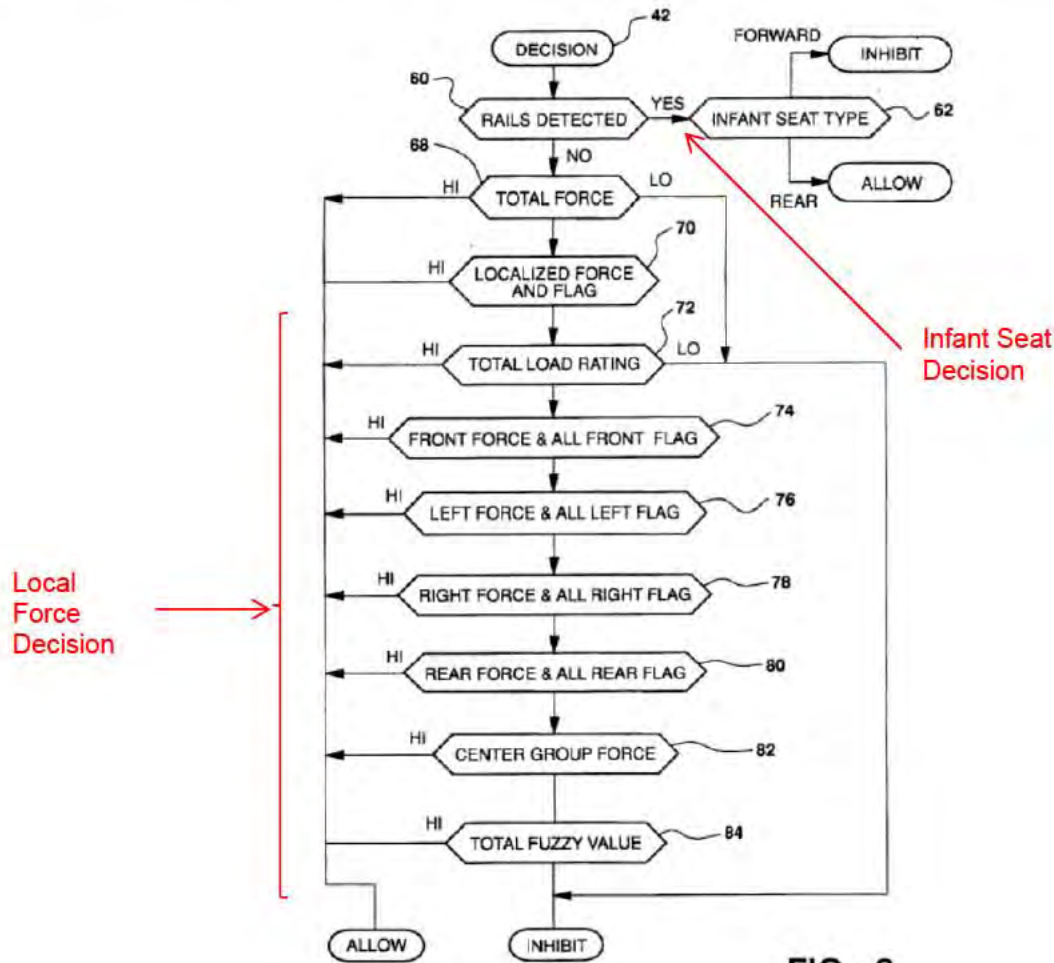

FIG - 8

Similarly, the specification states that “[a] microprocessor is programmed to sample each sensor, determine a total weight parameter by summing the pressures, and determine the pattern of pressure distribution by evaluating a local group of sensors. Total force is sufficient for proper detection of adults in the seat, but the pattern recognition provides improved detection of small children and infant seats.” *Id.* at 1:67-2:6. The patent also describes “[t]he pattern recognition for detecting children.” *Id.* at 2:12-20. All of this language indicates that pattern recognition is used to detect small children, not just infant seats.

Defendants also argue that because the specification describes determining “the pattern of pressure distribution by evaluating local groups of sensors,” *id.* at 2:2-3, and claim 1 describes “local force” and “local pressure,” claim 1 must deal with a “pattern.” *Jt. Br., Dkt. 53* at 51-52. There is some force to this position, but including “pattern” in the construction, as Defendants propose, is likely to be misleading. Any comparison of local and total forces perhaps inherently concerns a “pattern,” but again, the words of claim 1 adequately describe the particular pattern that is suggested. The specification does not justify

UNITED STATES DISTRICT COURT
CENTRAL DISTRICT OF CALIFORNIA

CIVIL MINUTES – GENERAL

Case No. LA CV14-02454 JAK (JEMx) -- AND RELATED CASES

Date April 17, 2015

Title Signal IP v. American Honda Motor Co., Inc. -- AND RELATED CASES

layering an additional “pattern” requirement onto the claim.

Defendants also include the word “sampling” in their proposed construction. *Id.* Sampling is discussed twice in the ‘375 Patent. The summary of the invention states that “[a] microprocessor is programmed to sample each sensor, determine a total weight parameter by summing the pressures, and determine the pattern of pressure distribution by evaluating local groups of sensors.” *Id.* at 1:67-2:3. Later, it describes the process shown in Figure 3 of the ‘375 Patent, which is reproduced below: “[o]ne sensor at a time is turned on, sampled four times and averaged” as part of the bias adjustment in box 38. *Id.* at 3:37-44. At box 42, “decision measures” are run. The decision measures determine total force, local force and whether an infant seat is present. *Id.* at 3:48-5:30.

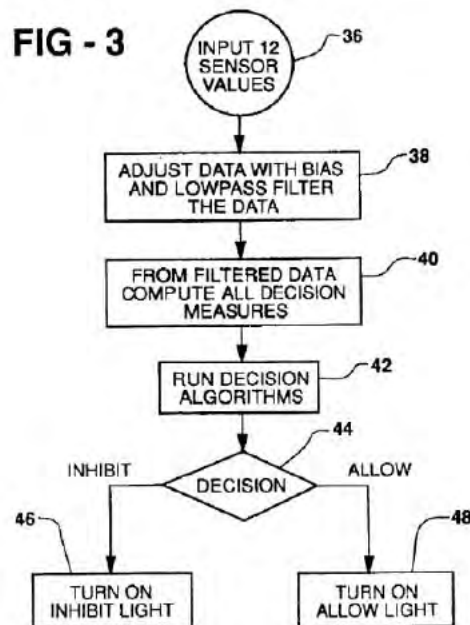

“Sampling” appears to be how the specification teaches obtaining measurements from the sensors. But, the specification does not specifically link sampling to force distribution. Including sampling would, therefore, import a limitation from the specification into the claims, and would also likely require further claim construction of “sampling” itself.

c. The Prosecution History

In an April 11, 1997 Office Action, the USPTO rejected all claims as obvious in light of U.S. Pats. No. 5,474,327 (“Schousek”) and 5,570,301 (“Barrus”). April 11, 1997 Office Action at 3, SIG00000494. The examiner stated that Barrus shows “determining from the pattern of loaded sensors whether an infant seat is present.” *Id.* at 5, SIG00000496. The patentee responded that Barrus did not make claim 1 obvious because “[a]lthough applicant has disclosed the use of pattern recognition to identify the

UNITED STATES DISTRICT COURT
CENTRAL DISTRICT OF CALIFORNIA

CIVIL MINUTES – GENERAL

Case No. LA CV14-02454 JAK (JEMx) -- AND RELATED CASES

Date April 17, 2015

Title Signal IP v. American Honda Motor Co., Inc. -- AND RELATED CASES

presence of an infant seat, pattern recognition is not used to identify the position of an occupant, as taught by Barrus.” June 13, 1997 Response to Office Action, SIG00000706. Thus, the patentee explicitly disclaimed the use of pattern recognition “to identify the position of an occupant.” “[W]here the patentee has unequivocally disavowed a certain meaning to obtain his patent, the doctrine of prosecution disclaimer attaches and narrows the ordinary meaning of the claim congruent with the scope of the surrender.” *Omega Eng’g, Inc. v. Raytek Corp.*, 334 F.3d 1314, 1324 (Fed. Cir. 2003). For these reasons, the prosecution history weighs against using the word “pattern” in claim 1.

d. The Extrinsic Evidence

The extrinsic evidence does not bear on this question.

e. Conclusion

The claims do not support adding the terms “pattern” or “sampling” to describe the force distribution. Although the specification refers to a “pattern” in connection with the method of claim 1, and although any comparison of total and localized forces inherently involves a type of pattern, the use of a “pattern” for occupant position identification was explicitly disclaimed in the prosecution history. Moreover, “pattern” is used in the dependent claims. As for Plaintiff’s proposed construction, it adds nothing not already in the claim. For these reasons, no construction is necessary.

Term No. 7: “On the Passenger Seat” (Claim 1)

Plaintiff’s Proposal	Defendants’ Proposal	Court’s Construction
Plain and ordinary meaning. To the extent a construction is necessary, Plaintiff proposes: “Located such that weight on the passenger seat can be detected.”	<u>Honda, Kia, Mazda, Mitsubishi, Nissan:</u> “on the top surface of the seat, just under the seat cover”	None necessary.

a. The Language of the Claims

Claim 1 requires the sensors to be: (1) “on the passenger seat,” (2) arranged in an “array . . . defining a plurality of seat areas,” and (3) used to “measur[e] the force” on the seat. ‘375 Patent at 5:40-41, 45, 50. The claim does not require the sensors to be in any particular position relative to the seat cover. The sensors could be in various positions relative to the seat cover and still be “on the passenger seat,” so long as they arranged in an array, define a plurality of seat areas, and can measure force on the seat.

b. The Specification

In the specification, the sensors are described as being “judicially [likely, “judiciously”] located in the seat,” *id.* at 1:59, “arranged symmetrically about the seat centerline,” *id.* at 1:63-64, and “embedded in a

UNITED STATES DISTRICT COURT
CENTRAL DISTRICT OF CALIFORNIA

CIVIL MINUTES – GENERAL

Case No. LA CV14-02454 JAK (JEMx) -- AND RELATED CASES

Date April 17, 2015

Title Signal IP v. American Honda Motor Co., Inc. -- AND RELATED CASES

seat cushion.” *Id.* at 5:32-33. In the disclosed embodiment, the sensors are in the seat cushion, near but below the surface of the seat. This does not provide support for requiring the sensors to be “just under the seat cover.”

Figure 2 of the ‘375 Patent, which is reproduced below, shows the arrangement of the sensors in the disclosed embodiment, described as “[t]he mounting arrangement of sensors 28 on a bottom bucket seat cushion.” *Id.* at 3:21-22. This figure shows a detailed example of the sensor arrangement in the plane of the seat cushion, but nothing about their position relative to the top or bottom of the seat cushion.

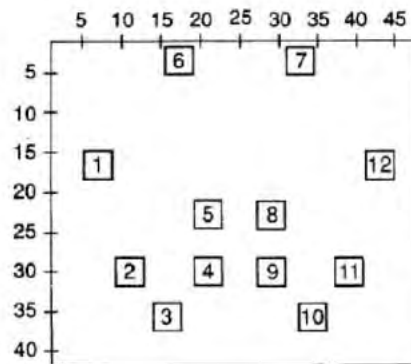

Defendants argue that, because the Abstract describes “sensors on a vehicle passenger seat,” the disclosed position is more than a preferred embodiment, and that it is instead essential to the invention that the sensors be “on the top surface of the seat, just under the seat cover.” *Jt. Br.*, Dkt. 53 at 55-57. This is not convincing because the claim itself also says that the sensors are “on” the seat, but, as described in the previous section, this does not limit the placement of the sensors to a specific surface or section of the seat.

c. The Prosecution History

The prosecution history does not bear on this question.

d. The Extrinsic Evidence

Defendants cite the ‘007 Patent (discussed *infra*): “It has been proposed . . . in U.S. Pat. No. 5,474,327 to Schousek . . . and in U.S. Pat. No. 5,732,375 . . . to incorporate pressure sensors in the passenger seat These disclosures teach the use of sensors on the top surface of the seat, just under the seat cover.” ‘007 Patent at 1:31-41. Plaintiff responds that “[t]his teaching is only found in the ‘327 Patent, which is not at issue here.” *Jt. Br.*, Dkt. 53 at 58. This teaching is not present expressly in either Schousek or the ‘375 Patent. Further, the ‘375 Patent had already issued when the application resulting in the ‘007 patent was filed, and the ‘007 Patent and the ‘375 Patent were prepared by different patent prosecutors. Although the characterization of the ‘375 Patent in the later patent provides some insight as to how a person of skill in the art would understand the ‘375 Patent’s disclosure, that evidence is

UNITED STATES DISTRICT COURT
CENTRAL DISTRICT OF CALIFORNIA

CIVIL MINUTES – GENERAL

Case No. LA CV14-02454 JAK (JEMx) -- AND RELATED CASES

Date April 17, 2015

Title Signal IP v. American Honda Motor Co., Inc. -- AND RELATED CASES

ambiguous. The patent simultaneously cites to the Schousek patent and the '375 Patent while failing to provide clarity or context through any precise citation to either.

e. Conclusion

Defendants have not demonstrated that it would be appropriate to restrict the allowable sensor positions to a narrowly defined area of the seat cushion. Plaintiff's proposed construction removes the restriction that the sensors are "on the passenger seat" altogether. For these reasons, this term is not construed at this time.¹⁰

Term No. 8: "Seat Area" (Claim 1)

Plaintiff's Proposal	Defendant's Proposal	Court's Construction
Plain and ordinary meaning. To the extent a construction is necessary, Plaintiff proposes "Area of the seat."	<u>Honda, Kia, Mazda, Mitsubishi, Nissan:</u> "area of the bottom seat cushion"	"a portion of the seat in which one or more sensors are located"

Defendants argue that the specifications of this patent and two others support narrowing the seat area to the area of the bottom seat cushion. Plaintiff counters that this would improperly import limitations from the specification onto the claims. *Jt. Br.*, Dkt. 53 at 60, 65.

a. The Language of the Claims

Claim 1 describes "defining a plurality of seat areas, at least one sensor located in each seat area." '375 Patent at 5:50-51. It also describes a "local pressure area," which exists "when the calculated total force is concentrated in one of said seat areas." *Id.* at 5:52-54. The local force is "the sum of forces sensed by each sensor located in the seat area in which the total force is concentrated." *Id.* at 5:55-57. Deployment is allowed "if the local force is greater than a predefined seat area threshold force." *Id.* at 5:58-59.

The claim specifies that the sensors are located in the various seat areas, and that the sensors are "on the passenger seat." *Id.* at 5:41, 50-51. The claim shows that the seat areas are some defined portions of the seat, but does not restrict them to the bottom seat cushion.¹¹

¹⁰ The parties provided no extrinsic evidence concerning the usage of "seat" in the industry. If necessary, the claim may be construed later in these proceedings on a more developed record.

¹¹ For example, Plaintiff proposes that sensors could be in the seat back. *Jt. Br.*, Dkt. 53 at 64-65. Defendants' *Markman* presentation contains a lengthy argument not present in the brief about the uselessness of placing sensors in the back of the seat. If such a configuration is actually useless, it is not likely to be at issue in this case.

UNITED STATES DISTRICT COURT
CENTRAL DISTRICT OF CALIFORNIA

CIVIL MINUTES – GENERAL

Case No. LA CV14-02454 JAK (JEMx) -- AND RELATED CASES

Date April 17, 2015

Title Signal IP v. American Honda Motor Co., Inc. -- AND RELATED CASES

b. The Specification

Although the specification does not refer expressly to “seat areas,” it does explain that the sensors are divided into groups -- a left pair, a right pair, a front pair, a rear pair and a center group. *Id.* at 3:21-32. A sensor arrangement is illustrated in Figures 2 and 7 of the ‘375 Patent. The specification also describes that the sensors are “judicially [likely, “judiciously”] located in the seat,” *id.* at 1:59, and “embedded in a seat cushion.” *Id.* at 5:32-33. Further, Figure 2 of the ‘375 Patent (see term 7, above) shows the “[t]he mounting arrangement of sensors 28 on a bottom bucket seat cushion.” *Id.* at 3:21-22. Thus, the specification teaches placing the sensors on a bottom seat cushion, and does not expressly teach placing them anywhere else.

Notwithstanding the foregoing, Plaintiff contends that restricting the seat areas of claim 1 to the bottom seat cushion “violates the fundamental canon of claim construction . . . ‘that limitations from the specification may [not] be read into the claims.’” *Jt. Br.*, Dkt. 53 at 65 (quoting *Sjolund v. Musland*, 847 F.2d 1573, 1581 (Fed. Cir. 1988)). Indeed, that the sensors are in the bottom seat cushion in the disclosed example does not mean that this location should be imported into the “seat area” of claim 1. See *Phillips v. AWH Corp.*, 415 F.3d 1303, 1314-15 (Fed. Cir. 2005).

c. The Prosecution History

The prosecution history does not bear on this question.

d. The Extrinsic Evidence

Defendants argue that the state of the art when the ‘375 Patent was filed -- Schousek -- supports their proposed construction. In Schousek, according to Defendants, “sensors are exclusively described as being mounted on the bottom seat cushion of the passenger seat.” Even if this were established, it would be improper to import a limitation from a different patent into claim 1 of the ‘375 Patent.

e. Conclusion

The Court adopts the construction that a “seat area” is “a portion of the seat in which one or more sensors are located.”

Term No. 9: “Sensor Array / Array of Force Sensors” (Claim 1)

Plaintiff’s Proposal	Defendants’ Proposal	Court’s Construction
Plain and ordinary meaning. To the extent a construction is necessary, Plaintiff proposes “Ordered grouping of [force] sensors.”	<u>Honda, Kia, Mazda, Mitsubishi, Nissan:</u> “an ordered or symmetrical grouping of [force] sensors arranged in rows and columns”	“ordered grouping of [force] sensors”

UNITED STATES DISTRICT COURT
CENTRAL DISTRICT OF CALIFORNIA

CIVIL MINUTES – GENERAL

Case No. LA CV14-02454 JAK (JEMx) -- AND RELATED CASES

Date April 17, 2015

Title Signal IP v. American Honda Motor Co., Inc. -- AND RELATED CASES

The parties agree that the force sensors are in an “ordered grouping,” and that “force” is “pressure that is indicative of weight.” Defendants propose the additional limitation that the sensors are in “an ordered or symmetrical grouping” and “arranged in rows and columns.” Plaintiff argues that Defendants’ proposed construction would improperly import limitations from the specification onto the claim. Jt. Br., Dkt. 53 at 66, 71.

Defendants cite *Bickerstaff v. Dr. Shrink, Inc.*, 1999 U.S. App. LEXIS 21601, at *10 (Fed. Cir. Sept. 3, 1999) (“The court concluded that the term ‘array’ refers to ‘a rectangular arrangement of quantities arranged in rows and columns.’”). Jt. Br., Dkt. 53 at 67. However, on appeal, the Federal Circuit did not consider the correctness of that construction, but rather revisited the construction of the term “cowl.” *Bickerstaff*, 1999 U.S. App. LEXIS 21601, at *10, *13. In construing “array,” the district court started with the dictionary definitions, and then used the patent’s figures to select among those definitions. *Bickerstaff v. Dr. Shrink, Inc.*, No. 1:97 CV 528, 1998 U.S. Dist. LEXIS 14722, at *11 (W.D. Mich. Aug. 13, 1998). This reflects the dictionary-centric approach to claim construction that prevailed at that time, and which has been replaced by a greater focus on the intrinsic record. See *Phillips v. AWH Corp.*, 415 F.3d 1303, 1321 (Fed. Cir. 2005) (“The main problem with elevating the dictionary to such prominence is that it focuses the inquiry on the abstract meaning of words rather than on the meaning of claim terms within the context of the patent.”). Thus, *Bickerstaff* has minimal force here.

Plaintiff cites *Gart v. Logitech, Inc.*, 254 F.3d 1334, 1342-43 (Fed. Cir. 2001) (holding that courts should not “improperly add a limitation appearing in the specification and the drawings, but not appearing in the unambiguous language of the claim”). Jt. Br., Dkt. 53 at 70. Defendants argue *Gart* is not relevant because “[u]nlike the patent at issue in *Gart*, the ‘375 Patent teaches only one embodiment and refers to the disclosed arrangement as the invention.” *Id.* at 68. However, the Federal Circuit “has expressly rejected the contention that if a patent describes only a single embodiment, the claims of the patent must be construed as being limited to that embodiment.” *Liebel-Flarsheim Co. v. Medrad, Inc.*, 358 F.3d 898, 906 (Fed. Cir. 2004) (collecting cases).

a. *The Language of the Claims*

Claim 1 discloses “an array of force sensors on the passenger seat.” ‘375 Patent at 5:40-41. The claimed method involves “calculating the total force of the sensor array.” *Id.* at 5:46. At least one sensor is located in one of several overlapping seat areas, and this scheme is used to determine local pressures in a given seat area as the sum of forces of the sensors in a given seat area. *Id.* at 5:50-54. Thus, the claim shows that the sensors are arranged in a plurality of seat areas, that the sensor array describes the layout of all the sensors and that the sensors are on the passenger seat. The claim does not require anything further as to the symmetry or formation in which the sensors are arranged.

b. *The Specification*

Figures 2 and 7 of the ‘375 Patent depict two seat sensor position diagrams, which are reproduced below:

UNITED STATES DISTRICT COURT
CENTRAL DISTRICT OF CALIFORNIA

CIVIL MINUTES – GENERAL

Case No. LA CV14-02454 JAK (JEMx) -- AND RELATED CASES

Date April 17, 2015

Title Signal IP v. American Honda Motor Co., Inc. -- AND RELATED CASES

FIG - 2

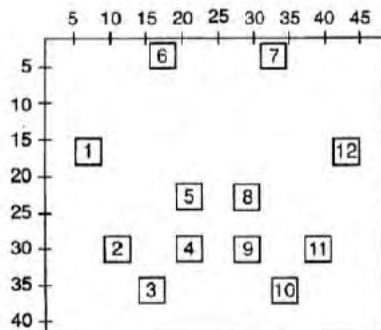

FIG - 7

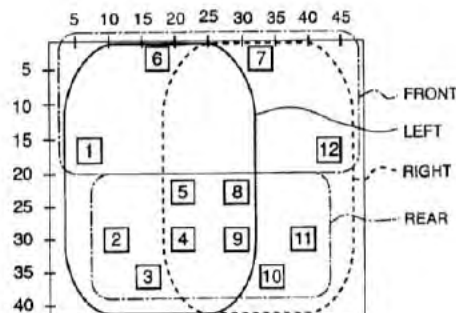

Figure 2 “is a position diagram of seat sensors for the system of FIG. 1, according to the invention,” and Figure 7 “is a position diagram of seat sensors illustrating sensor grouping.” ‘375 Patent at 2:30-43. The specification discloses that the “sensors are arranged symmetrically about the seat centerline.” *Id.* at 1:62-65. As the diagrams show, this means a symmetry on the x-axis (on either side of the vertical centerline), but not on the y-axis. The arrangement is also described as a “pattern of resistive sensors.” *Id.* at 5:32.

Although the figures present an ordered and symmetrical arrangement of sensors mapped with rows and columns, the specification never uses the words “rows” or “columns,” and any two-dimensional distribution can be mapped with rows and columns. Given the distribution, and lack of supporting language in the specification, it is far from clear that a defining feature of the sensor placement is that they are arranged in “rows” and “columns.”

Even assuming that the sensors in the figures are arranged in rows and columns, Defendants would have to justify importing that limitation into the claims. Defendants argue that doing so is appropriate here because the patent “refers to the disclosed arrangement as the invention.” *Jt. Br.*, Dkt. 53 at 68. However, the only time the sensor arrangement is referred to as “the invention” is in the brief description of Figure 2: “Fig. 2 is a position diagram of seat sensors for the system of Fig. 1, according to the invention.” *Id.* at 2:30-31.

It is true that, in some circumstances, a patentee’s consistent reference to a certain limitation or a preferred embodiment as “this invention” or the “present invention” can serve to limit the scope of the entire invention On the other hand, we have found that use of the phrase “present invention” or “this invention” is not always so limiting, such as where the references to a certain limitation as being the “invention” are not uniform, or where other portions of the intrinsic evidence do not support applying the limitation to the entire patent.

Absolute Software, Inc. v. Stealth Signal, Inc., 659 F.3d 1121, 1136 (Fed. Cir. 2011). Here, a single, brief reference that Figure 2 is a diagram of sensors “according to the invention” is not enough to show that the particular arrangement shown in Figure 2 is “the invention.”

UNITED STATES DISTRICT COURT
CENTRAL DISTRICT OF CALIFORNIA

CIVIL MINUTES – GENERAL

Case No. LA CV14-02454 JAK (JEMx) -- AND RELATED CASES

Date April 17, 2015

Title Signal IP v. American Honda Motor Co., Inc. -- AND RELATED CASES

Overall, the specification and case law do not support imposing Defendants' proposed limitations on claim 1.

c. *The Prosecution History*

The prosecution history does not bear on this question.

d. *The Extrinsic Evidence*

Both parties cite dictionary definitions in support of their proposed constructions. Defendants cite two dictionary definitions. First, *Webster's II New College Dictionary* defines "array," among many other definitions, as "a rectangular arrangement of quantities in rows and columns, as in a matrix." *Webster's II New College Dictionary* 62 (1999), JA-0299. Defendants cite definition number four, prefaced "Math." Defendants also cite *Merriam-Webster's School Dictionary*, defining "array" as, among other things: "A group of mathematical elements (as numbers or letters) arranged in rows or columns." *Merriam-Webster's School Dictionary* 46 (1999), JA-0302. Again this is the fourth definition listed. Plaintiff points to the first definition in *Merriam-Webster's School Dictionary*, "regular order or arrangement." *Id.*

Overall, these divergent dictionary definitions are of minimal importance. "A claim should not rise or fall based upon the preferences of a particular dictionary editor, or the court's independent decision, uninformed by the specification, to rely on one dictionary rather than another." *Phillips*, 415 F.3d at 1322. As Defendants noted elsewhere, "our inquiry here starts with the intrinsic record, including the specification, and not with a dictionary definition of the disputed term." *Jt. Br.*, Dkt. 53 at 77 (quoting *Power Integrations, Inc. v. Fairchild Semiconductor Int'l, Inc.*, 711 F.3d 1348, 1362 (Fed. Cir. 2013)).

e. *Conclusion*

For the reasons described above, the Court construes "sensor array" and "array of force sensors" as "ordered grouping of [force] sensors."

Term No. 10: "Seat Area Threshold Force" (Claim 1)

Plaintiff's Proposal	Defendants' Proposal	Court's Construction
<p>Plain and ordinary meaning.</p> <p>To the extent a construction is necessary, Plaintiff proposes: "A minimum force that allows airbag deployment based on the forces in one of the seat areas."</p>	<p><u>Honda and Mazda:</u></p> <p>"A minimum force different than the total threshold force that allows airbag deployment based on the forces measured by the sensors in one of the seat areas."</p>	<p>"a minimum force different than the total threshold force that allows airbag deployment based on the forces measured by the sensors in one of the seat areas"</p>

The parties agree that the seat area threshold force is "a minimum force that allows airbag deployment

UNITED STATES DISTRICT COURT
CENTRAL DISTRICT OF CALIFORNIA

CIVIL MINUTES – GENERAL

Case No. LA CV14-02454 JAK (JEMx) -- AND RELATED CASES

Date April 17, 2015

Title Signal IP v. American Honda Motor Co., Inc. -- AND RELATED CASES

based on the forces in one of the seat areas.” Jt. Br., Dkt. 53 at 71-72. They also agree that “force” is “pressure that is indicative of weight,” and “total threshold force” is “a minimum force that allows airbag deployment based on the total force sensed by the entire sensor array.” JCC, Dkt. 46 at 2. Defendants Honda and Mazda argue that the construction should specify that this force is “different than the total threshold force.” Jt. Br., Dkt. 53 at 71-72.

a. The Language of the Claims

In claim 1, airbag deployment is allowed if the total force exceeds a “total threshold force.” ‘375 Patent at 5:48-49. There is a “local pressure area” if the total force is concentrated in one seat area, and deployment is also allowed if the local force is greater than “a predefined seat area threshold force.” *Id.* at 5:53-55, 58-59. The claim language demonstrates that the “total threshold force” and “seat area threshold force” are distinct concepts. Further, after determining whether the total force exceeds the total threshold force, the method checks for a local concentration, sums the forces in a local area, then allows deployment if the local force exceeds the seat area threshold force. *Id.* at 5:48-49, 53-55, 58-59. If the total threshold force were not distinct from the seat area threshold force, these latter steps would be unnecessary; the local and total threshold forces would always be the same. Thus, the words of the claim support Defendants’ contention that the total threshold force is different than the seat area threshold force.

b. The Specification

The phrase “seat area threshold force” does not appear in the specification. The specification explains that deployment may be allowed if the total force is above a “high threshold,” or if “localized force for a sensor group is above a threshold.” *Id.* at 5:12-15. The specification does not limit the seat area threshold force any more than the claim does by its own terms.

c. The Prosecution History

In response to an April 11, 1997 Office Action, the patentee argued that the “claims set forth a method of allowing deployment even though the total force sensed by the seat sensors is less than a total threshold force.” June 19, 1997 Office Action Response, SIG00000706. With this statement, the patentee was making explicit what is already implicit in the claim -- that the seat area threshold force should be smaller than the total force threshold.

d. The Extrinsic Evidence

The extrinsic evidence does not bear on this question.

e. Conclusion

Because the intrinsic evidence supports the proposed addition of Honda and Mazda distinguishing the seat area threshold force from the total threshold force, this addition is adopted. “Seat area threshold force” is construed to mean “a minimum force different than the total threshold force that allows airbag deployment based on the forces measured by the sensors in one of the seat areas.”

UNITED STATES DISTRICT COURT
CENTRAL DISTRICT OF CALIFORNIA

CIVIL MINUTES – GENERAL

Case No. LA CV14-02454 JAK (JEMx) -- AND RELATED CASES

Date April 17, 2015

Title Signal IP v. American Honda Motor Co., Inc. -- AND RELATED CASES

Term No. 11: "Concentrated" (Claim 1)

Plaintiff's Proposal	Defendant's Proposal	Court's Construction
Not indefinite / Plain and ordinary meaning.	<u>VW / Bentley: Indefinite</u>	Indefinite

VW/Bentley argue that this claim term is indefinite because it does not inform those skilled in the art of the claimed invention with reasonable certainty. VW/Bentley point to an absence of supporting intrinsic evidence, and contend that although “the term ‘concentrated’ is one of degree,” the scope of the term is not defined anywhere in the patent. Jt. Br., Dkt. 53 at 75-76. Plaintiff argues that the term is not indefinite, and proposes that it should carry plain meaning “because the term ‘concentrated’ is not a technical term or term of art, but rather a common word that any lay juror would easily understand.” *Id.* at 78.

“Claim language employing terms of degree has long been found definite where it provided enough certainty to one of skill in the art when read in the context of the invention.” *Interval Licensing LLC v. AOL, Inc.*, 766 F.3d 1364, 1370 (Fed. Cir. 2014).

Although absolute or mathematical precision is not required, it is not enough, as some of the language in our prior cases may have suggested, to identify “some standard for measuring the scope of the phrase.” . . . The Supreme Court explained that a patent does not satisfy the definiteness requirement of § 112 merely because “a court can ascribe some meaning to a patent’s claims.” The claims, when read in light of the specification and the prosecution history, must provide objective boundaries for those of skill in the art.

Id. at 1370-71 (citations omitted).

Plaintiff responds that Defendants have not provided any extrinsic evidence showing that the term is indefinite to a skilled artisan. Jt. Br., Dkt. 53 at 10 (quoting *Nautilus, Inc. v. Biosig Instruments, Inc.*, 134 S. Ct. 2120, 2129 (2014)) (“definiteness is to be evaluated from the perspective of someone skilled in the relevant art”). Given that the indefiniteness inquiry is taken from the perspective of a skilled artisan, Plaintiff argues that Defendants have not met the required burden of providing clear and convincing evidence. *Id.* at 11 (citing *Microsoft Corp. v. i4i Ltd. P’ship*, 131 S. Ct. 2238 (2011)). VW/Bentley argue that extrinsic evidence is not required to prove indefiniteness. *Id.* at 6 (quoting *Interval Licensing LLC v. AOL, Inc.*, 766 F.3d 1364, 1371 n.6 (2014)) (“[W]e find it unnecessary to rely on [expert] testimony (or any other extrinsic evidence) to reach our conclusion. Like the district court, we find the claims indefinite based on the claims, the written description, and the prosecution history.”) VW/Bentley also quote from *Prolifiq Software*: “where a claim term allows the scope of the invention to be determined by the unrestrained, subjective opinion of the person practicing the invention, then no one, including a person skilled in the art, can determine with reasonable clarity the scope of the invention.” *Id.* at 7 (quoting *Prolifiq Software Inc. v. Veeva Systems, Inc.*, No. C 13–03644 SI, 2014 WL 3870016, at *8 n.6

UNITED STATES DISTRICT COURT
CENTRAL DISTRICT OF CALIFORNIA

CIVIL MINUTES – GENERAL

Case No. LA CV14-02454 JAK (JEMx) -- AND RELATED CASES

Date April 17, 2015

Title Signal IP v. American Honda Motor Co., Inc. -- AND RELATED CASES

(N.D. Cal. Aug. 6, 2014)).

VW/Bentley are correct that, in certain circumstances, a claim can be properly found indefinite without extrinsic evidence. Further, Plaintiff was free to submit evidence that the term had an established meaning in the field, but did not do so.

a. The Language of the Claim

The term is used in claim 1 as follows: “determining the existence of a local pressure area when the calculated total force is concentrated in one of said seat areas,” and “calculating a local force . . . in the seat area in which the total force is concentrated.” ‘375 Patent at 5:52-57. Given that the total force is described as being in “the seat area” or “one of said seat areas,” the claim gives the impression that 100% of the referred-to force must be in a single seat area for it to be “concentrated” there.

The method comprises the steps of: (1) measuring the force detected by each sensor, (2) calculating the total force of the sensor array; (3) allowing deployment if this exceeds a total threshold force; (4) defining a plurality of seat areas and determining whether the total force is concentrated in one of said seat areas; (5) calculating the local force in the seat area in which the total force is concentrated; and (6) allowing deployment if the local force is greater than a predefined seat area threshold force. If 100% of the force were concentrated in a local area according to step (4), and the total force had already been calculated in step (2), then calculating the local force in step (5) would be unnecessary. Step (5) would, therefore, not make sense unless the local force could differ from the total force. That understanding would require “concentrated” to not mean 100% concentrated.

For these reasons it is unclear from the language of the claim whether “concentrated” means 100% of the force is in a given area, or some smaller amount.

b. The Specification

The specification explains that “the algorithm determines if the pressure is *all* concentrated in one group by summing the load ratings of the sensors in each group and comparing to the total load rating.” ‘375 Patent at 4:18-27 (emphasis added). Then the specification explains how this determination is made: “The algorithm determines if the pressure is *all* concentrated in one group by summing the load ratings of the sensors in each group and comparing to the total load rating. If the rating sum of any group is equal to the total rating, a flag is set for each group.” *Id.* at 4:24-29 (emphasis added). Thus, the specification clearly teaches that *all* the pressure is concentrated, i.e. located, in one group. Plaintiff argues that this example shows that the term is not indefinite, *Jt. Br.*, Dkt. 53 at 79, but does not point to any other portion of the specification demonstrating that less than 100% would or would not be considered “concentrated.”

c. The Prosecution History

The prosecution history does not bear on this question.

UNITED STATES DISTRICT COURT
CENTRAL DISTRICT OF CALIFORNIA

CIVIL MINUTES – GENERAL

Case No. LA CV14-02454 JAK (JEMx) -- AND RELATED CASES

Date April 17, 2015

Title Signal IP v. American Honda Motor Co., Inc. -- AND RELATED CASES

d. The Extrinsic Evidence

Plaintiff refers to a dictionary defining “concentrated” as “clustered or gathered together closely.” Jt. Br., Dkt. 53 at 79 n.31 (citing Dictionary.com, <http://dictionary.reference.com/browse/concentrated?s=t>). This does not address the particular issue posed by the claim language or specification.

e. Conclusion

If the claim were limited to concentrations of 100%, as the specification suggests, it would be sufficiently definite. But neither Plaintiff nor VW/Bentley takes that position. Nothing in the claims or specification allows a person of skill in the art to know the “objective boundaries” of the claim, *Interval Licensing*, 766 F.3d at 1370: whether 75%, 51%, or 33% of the force counts as “concentrated” in one group. “[A] patent is invalid for indefiniteness if its claims, read in light of the specification delineating the patent, and the prosecution history, fail to inform, with reasonable certainty, those skilled in the art about the scope of the invention.” *Nautilus, Inc. v. Biosig Instruments, Inc.*, 134 S. Ct. 2120, 2124 (2014). The “concentrated” term here fails that standard. Accordingly, Claim 1 of the ‘375 Patent is invalid as indefinite.

C. The ‘007 Patent¹²

The ‘007 Patent was issued on January 4, 2000 to assignee Delphi Technologies, Inc. (“Delphi”), disclosing an occupant detection method and apparatus for an air bag system using pressure sensors to allow or inhibit airbag deployment based on passenger weight. ‘007 Patent at Abstract. Plaintiffs assert that Defendants infringe 10 of the 27 claims in the ‘007 Patent.¹³ Jt. Report, Dkt. 35 at 4. Ten terms have been presented for construction, and Defendants contend that several of them are indefinite. JCC, Dkt. 46 at 30-39.

The ‘007 Patent is a continuation-in-part of the ‘375 Patent, which is described above. *Id.* at 1:4-6. The ‘007 Patent incorporates the ‘375 Patent by reference and discloses additional improvements for distinguishing heavy and light occupants and operating under dynamic conditions. *Id.* at 1:42-48. According to the invention, air bag deployment is inhibited when a seat is empty or occupied by a small child, and allowed when occupied by a larger passenger. *Id.* at 2:55-58. Figure 1 of the ‘007 patent (below) shows a typical airbag (or supplemental inflatable restraint -- “SIR”) system.

¹² The ‘007 Patent is provided as Exhibit I, JA-0279-89.

¹³ Claims 9, 18, and 22 are asserted only against Mazda. Joint Rep., Dkt. 35 at 4.

UNITED STATES DISTRICT COURT
CENTRAL DISTRICT OF CALIFORNIA

CIVIL MINUTES – GENERAL

Case No. LA CV14-02454 JAK (JEMx) -- AND RELATED CASES

Date April 17, 2015

Title Signal IP v. American Honda Motor Co., Inc. -- AND RELATED CASES

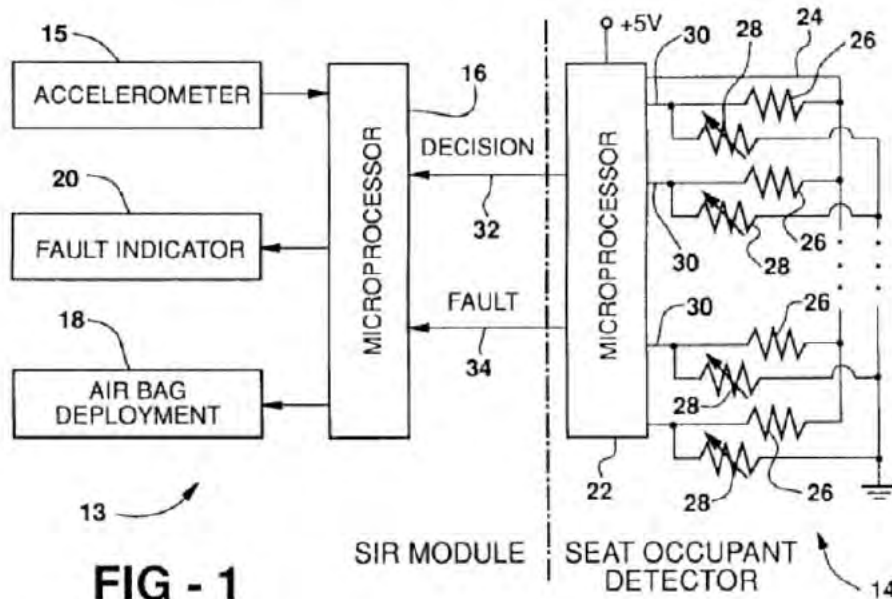

FIG - 1
PRIOR ART

Id. at 1:15-16, 2:18-19. An accelerometer senses an impending crash and a microprocessor receives signals from the accelerometer and determines whether to deploy an air bag. *Id.* at 2:46-49. On the other side of the figure, seat occupant detectors communicate with a separate microprocessor, which determines whether there is an appropriate occupant for airbag deployment. *Id.* at 3:4-7. The seat detector uses a series of voltage dividers made of resistors in series with a pressure sensor or variable resistor. *Id.* at 2:64-3:2. The microprocessor analyzes sensor voltage for passenger information. *Id.* at 2:61-3:7.

The positions of the sensors are shown in Figure 2 of the '007 patent, which is reproduced below with annotations added. *Id.* at 2:20-21.

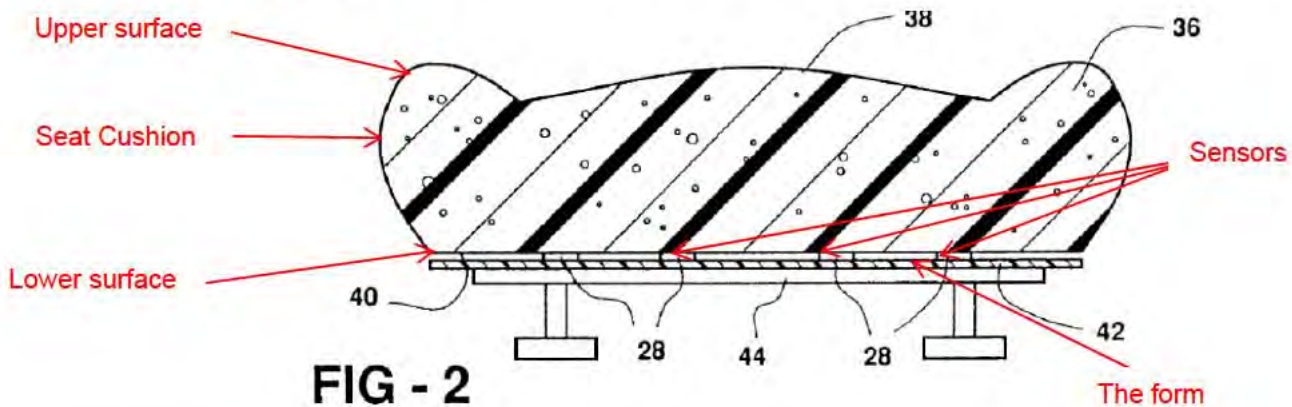

FIG - 2

UNITED STATES DISTRICT COURT
CENTRAL DISTRICT OF CALIFORNIA

CIVIL MINUTES – GENERAL

Case No. LA CV14-02454 JAK (JEMx) -- AND RELATED CASES

Date April 17, 2015

Title Signal IP v. American Honda Motor Co., Inc. -- AND RELATED CASES

The seat cushion has an upper surface 38 and a lower surface 40. *Id.* at 3:21-22. The lower surface is “seated on a rigid sheet or plastic form.” *Id.* at 3:21-23. The form “holds a dozen pressure sensors 28 on its upper surface so that the sensors are pressed against the bottom surface 40 of the seat cushion.” *Id.* at 3:24-27.

Figure 4 of the ‘007 Patent, which is reproduced below, is a flowchart overview of the operation. *Id.* at 3:36. The microprocessor reads the sensor values. *Id.* at 3:37-38. One sensor at a time is turned on and sampled once every 100 ms. *Id.* at 3:40-41. The readings are then bias corrected -- a bias calibrated for each sensor is subtracted from each sensor reading. *Id.* at 3:37-41. Then, decision measures are computed and decision algorithms are run, issuing a signal to either inhibit or allow deployment. *Id.* at 3:41-46.

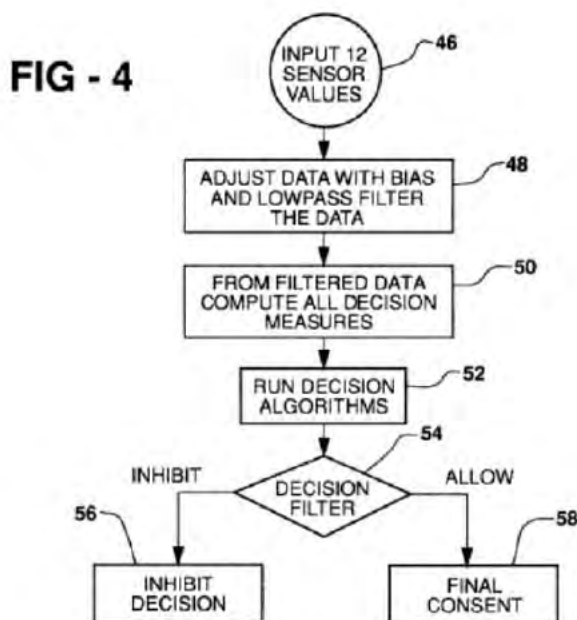

The decision measures may involve calculation of the total force, which is the sum of: the sensor outputs; the total force threshold; the sensor load ratings; the long term average of the sensor readings; and group sensor measures and thresholds. *Id.* at 3:48-55; 4:11-15.

UNITED STATES DISTRICT COURT
CENTRAL DISTRICT OF CALIFORNIA

CIVIL MINUTES – GENERAL

Case No. LA CV14-02454 JAK (JEMx) -- AND RELATED CASES

Date April 17, 2015

Title Signal IP v. American Honda Motor Co., Inc. -- AND RELATED CASES

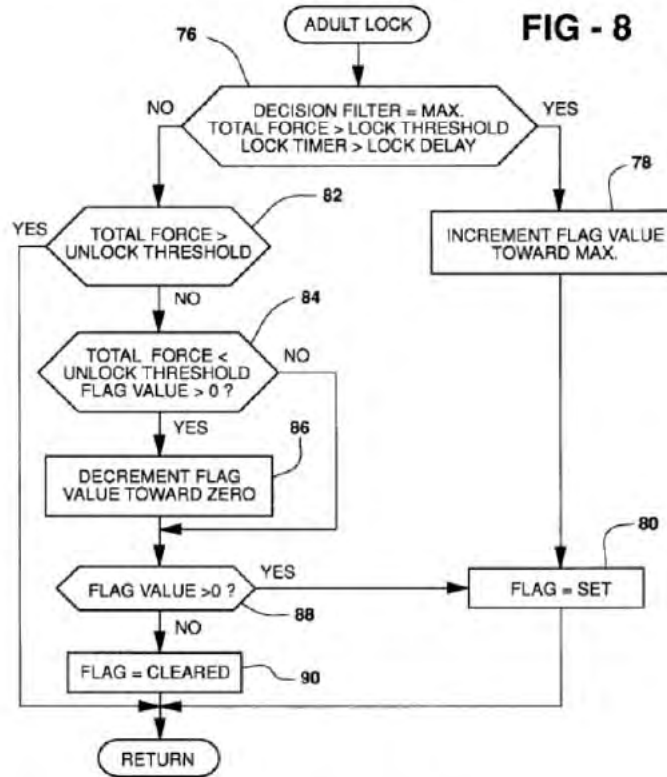

The main decision algorithm uses an “Adult Lock Flag” as shown in Figure 8 of the ‘007 Patent (above). *Id.* at 4:36-37. A lock threshold and an unlock threshold are used to determine whether an “adult,” or occupant above a threshold mass, is in the seat. *Id.* at 4:36-44. A lock timer measures the time after the vehicle ignition is turned on, and a lock delay on the order of one to five minutes is used. *Id.* at 4:42-44.

A final decision algorithm for whether to deploy an airbag is shown in Figure 10 of the ‘007 Patent, which is reproduced below. *Id.* at 5:8-9. A counter tabulates from zero to 255, and is incremented if an allow decision is made and decremented if an inhibit decision is made. *Id.* at 5:9-13. Final consent to deploy is granted when the count exceeds 133. *Id.* at 5:13-14. If consent is granted, a count over 123 is needed to maintain the state, and if the count falls below 123, the consent is revoked and deployment is inhibited. *Id.* at 5:9-18. By averaging measures over time, the system can account for occupant movement. *Id.* at 5:31-33.

UNITED STATES DISTRICT COURT
CENTRAL DISTRICT OF CALIFORNIA

CIVIL MINUTES – GENERAL

Case No. LA CV14-02454 JAK (JEMx) -- AND RELATED CASES

Date April 17, 2015

Title Signal IP v. American Honda Motor Co., Inc. -- AND RELATED CASES

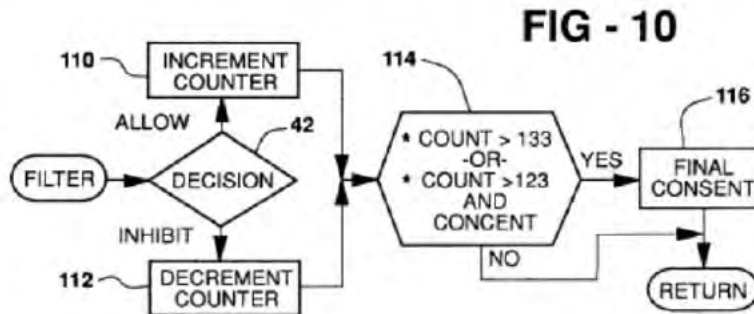

The asserted '007 Patent claims in which the disputed terms occur are reproduced below, with the disputed terms in bold:

1. In a vehicle restraint system having a controller for deploying air bags and **means for selectively allowing deployment according to the outputs of seat sensors responding to the weight of an occupant**, a method of allowing deployment according to sensor response including the steps of:
 - determining measures represented by individual sensor outputs and calculating from the sensor outputs a **relative weight parameter**;
 - establishing a first threshold of the **relative weight parameter**;
 - allowing deployment when the **relative weight parameter** is above the first threshold;
 - establishing a lock threshold above the first threshold;
 - setting a lock flag when the relative weight parameter is above the lock threshold and deployment has been allowed for a given time**;
 - establishing an unlock threshold at a **level indicative of an empty seat**;
 - clearing the **flag when the relative weight parameter is below the unlock threshold for a time**; and
 - allowing deployment while the **lock flag** is set.

17. In a vehicle restraint system having a controller for deploying air bags, **means for inhibiting and allowing deployment according to whether a seat is occupied by a person of at least a minimum weight** comprising:
 - seat sensors** responding to the weight of an occupant to produce sensor outputs;
 - a microprocessor coupled to the sensor outputs and programmed to inhibit and allow deployment according to sensor response and particularly programmed to determine measures represented by individual sensor outputs and calculate from the sensor outputs a **relative weight parameter**,
 - establish a first threshold of the **relative weight parameter**,
 - allow deployment when the **relative weight parameter** is above the first threshold,
 - establish a lock threshold above the first threshold,
 - set a lock flag when the relative weight parameter is above the lock threshold and deployment has been allowed for a given time**,
 - establish an unlock threshold at a **level indicative of an empty seat**,

UNITED STATES DISTRICT COURT
CENTRAL DISTRICT OF CALIFORNIA

CIVIL MINUTES – GENERAL

Case No. LA CV14-02454 JAK (JEMx) -- AND RELATED CASES

Date April 17, 2015

Title Signal IP v. American Honda Motor Co., Inc. -- AND RELATED CASES

clear the **flag** when the **relative weight parameter** is below the unlock threshold **for a time**, and
allow deployment while the **lock flag** is set.

18. Means for inhibiting and allowing deployment as defined in claim 17 wherein:
the seat comprises a resilient pad having a top surface for bearing an occupant and a bottom surface;
a support mounting the bottom surface; and
the **seat sensors** are arrayed on the bottom surface for sensing forces imposed by the weight of the occupant.
19. Means for inhibiting and allowing deployment as defined in claim 17 wherein:
the seat comprises a resilient pad having a top surface for bearing an occupant and a bottom surface;
a support including a panel supporting the bottom surface; and
the **seat sensors** are **arrayed in an interface defined by the bottom surface** and the panel for sensing forces imposed by the weight of the occupant.
20. Means for inhibiting and allowing deployment as defined in claim 17 wherein the microprocessor is further programmed to inhibit deployment when the **relative weight parameter** is below a **second threshold**.
21. Means for inhibiting and allowing deployment as defined in claim 17 wherein the **relative weight parameter** is the total force detected by all the sensors.
22. Means for inhibiting and allowing deployment as defined in claim 17 wherein **relative weight parameter** is a long term average of sensor outputs and the microprocessor is further programmed to average all sensor outputs over a plurality of sample events to obtain a cumulative average, and long term filter the cumulative average to obtain the long term average.

Term No. 12: "Seat Sensors" (Claims 1, 17, 18 & 19)

Plaintiff's Proposal	Defendant's Proposal	Court's Construction
Plain and ordinary meaning. To the extent a construction is necessary, Plaintiff proposes: "A plurality of sensors for a seat."	<u>Honda, Kia, Mazda, Mitsubishi, Nissan, Subaru, Mercedes, Porsche:</u> "a plurality of sensors in, or on a seat cushion"	None necessary.

The parties agree that "seat sensors" refers to "a plurality of sensors." Jt. Br., Dkt. 53 at 80. Defendants argue the sensors must be "in, or on a seat cushion," while Plaintiff argues the sensors merely need to be "for a seat." *Id.*

UNITED STATES DISTRICT COURT
CENTRAL DISTRICT OF CALIFORNIA

CIVIL MINUTES – GENERAL

Case No. LA CV14-02454 JAK (JEMx) -- AND RELATED CASES

Date April 17, 2015

Title Signal IP v. American Honda Motor Co., Inc. -- AND RELATED CASES

a. *The Language of the Claims*

Claims 1 and 17 are independent, while claims 18 and 19 depend from claim 17. Claim 1 begins, “[i]n a vehicle restraint system having a controller for deploying airbags and means for selectively allowing deployment according to the outputs of seat sensors responding to the weight of an occupant” ‘007 Patent at 5:42-45. Claim 17 describes “seat sensors responding to the weight of an occupant to produce sensor outputs.” *Id.* at 7:55-56. Neither of these claims mentions seat cushions or otherwise restricts the position of the seat sensors.

Claim 18 describes the seat in detail -- “the seat comprises a resilient pad having a top surface for bearing an occupant and a bottom surface; a support mounting the bottom surface; and the seat sensors are arrayed on the bottom surface for sensing forces imposed by the weight of the occupant.” *Id.* at 8:11-15. Similarly, claim 19 states that, “the seat comprises a resilient pad having a top surface for bearing an occupant and a bottom surface . . . and the seat sensors are arrayed in an interface defined by the bottom surface and the panel for sensing forces imposed by the weight of the occupant.” *Id.* at 8:19-25.

This resilient pad could be described as a cushion. Thus, the sensors of claim 18 and 19 are in or on a seat cushion. In claims 1 and 17, on the other hand, neither resilient pads nor seat cushions, nor any positional description of the seat sensors (other than “seat”) is provided. “When a limitation is included in several claims but is stated in terms of apparently different scope, there is a presumption that a difference in scope is intended and is real. . . . Such a presumption can be overcome, but the evidence must be clear and persuasive.” *Modine Mfg. Co. v. U.S. Int’l Trade Comm’n*, 75 F.3d 1545, 1551 (Fed. Cir. 1996) (citation omitted). Because claims 18 and 19 claim the same system as claims 1 and 17, but include a narrowing limitation that “the seat comprises a resilient pad” on which the seat sensors are placed, claim differentiation applies. There is a rebuttable presumption that claims 1 and 17 do not require the seat sensors to be in or on a seat cushion.

According to the claims themselves, claims 18 and 19 require the seat sensors to be in or on a seat cushion, and claims 1 and 17 presumptively do not.

b. *The Specification*

The summary of the invention describes a “number of sensors, judicially [sic, likely “judiciously”] located in the seat,” and states that “[t]he sensors are arranged in groups in the seat.” ‘007 Patent at 1:66, 2:4-5.

Figure 2 depicts “a cross section of a seat equipped with pressure sensors, according to the invention,” which is reproduced below with annotations added). *Id.* at 2:20-21.

UNITED STATES DISTRICT COURT
CENTRAL DISTRICT OF CALIFORNIA

CIVIL MINUTES – GENERAL

Case No. LA CV14-02454 JAK (JEMx) -- AND RELATED CASES

Date April 17, 2015

Title Signal IP v. American Honda Motor Co., Inc. -- AND RELATED CASES

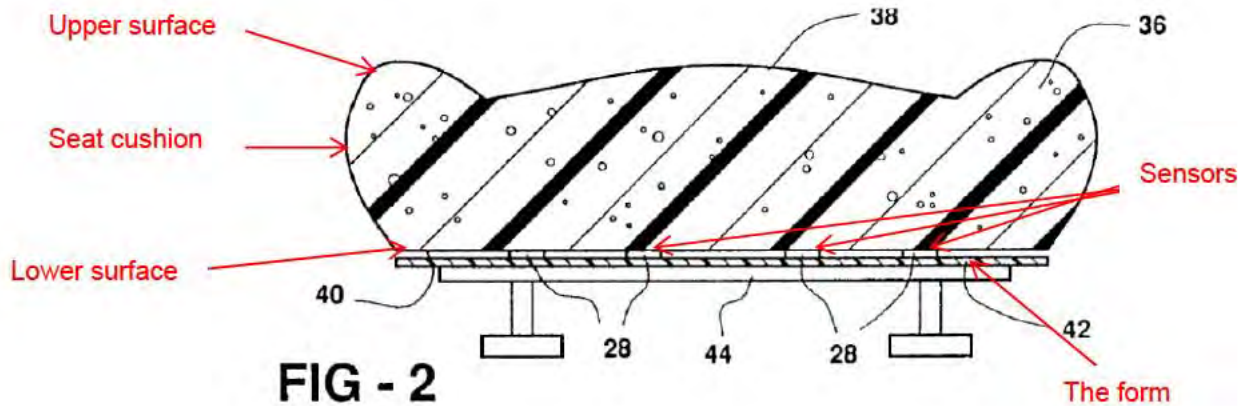

In Figure 2, a seat cushion is pictured. The seat cushion has an upper surface 38 and “a lower surface 40 seated on a rigid sheet or plastic form 42.” *Id.* at 3:21-23. The form “holds a dozen pressure sensors 28 on its upper surface so that the sensors are pressed against the bottom surface 40 of the seat cushion.” *Id.* at 3:24-27. Thus, according to Figure 2, the sensors are attached to a “form” and pressed against the bottom of a “seat cushion.”

The specification further explains that “[a]utomotive seat cushion[] assemblies do not normally have the form,” but here the form is useful to “hold the sensors” and “provide a reaction surface for the sensors, allowing each sensor to detect a force imposed by the weight of a seat occupant.” *Id.* at 3:27-30. This emphasizes the importance of having the sensors held by the form. The specification concludes: “The seat structure with sensors placed on the bottom surface of the seat cushion permits sensing of occupant weight without great sensitivity to localized forces on the top surface of the seat.” *Id.* at 5:34-38. The express teaching of the specification is that the sensors are attached to the form, not the cushion, although when attached, this could be considered “on” the bottom of the cushion.

As shown by this language, the specification repeatedly describes the sensors as being on the bottom of the seat cushion. However, limitations from the specification should not necessarily be imported onto the claims. *Phillips v. AWH Corp.*, 415 F.3d 1303, 1323 (Fed. Cir. 2005) (“although the specification often describes very specific embodiments of the invention, we have repeatedly warned against confining the claims to those embodiments”).

c. *The Prosecution and the Extrinsic Evidence*

The prosecution history and the extrinsic evidence do not bear on this question.

d. *Conclusion*

Because claims 18 and 19 clearly restrict the position of the sensors within the seat cushion, and claims 1 and 17 do not, there is a rebuttable presumption that the seat sensors of claims 1 and 17

UNITED STATES DISTRICT COURT
CENTRAL DISTRICT OF CALIFORNIA

CIVIL MINUTES – GENERAL

Case No. LA CV14-02454 JAK (JEMx) -- AND RELATED CASES

Date April 17, 2015

Title Signal IP v. American Honda Motor Co., Inc. -- AND RELATED CASES

should not be limited to in, or on, the seat cushion. No evidence has been offered to rebut this presumption. Further, it is not necessary to repeat the positional descriptions within claims 18 and 19. As to Plaintiff's proposed construction, it does little more than invert the order of "seat" and "sensors." Therefore, construction of this term is not required.

Term No. 13: "Lock Flag" / "Flag" (Claims 1, 17)

Plaintiff's Proposal	Defendant's Proposal	Court's Construction
<p>Plain and ordinary meaning.</p> <p>To the extent a construction is necessary, Plaintiff proposes: "Flag that is cleared when the relative weight parameter is below the unlock threshold for a time."</p>	<p><u>Honda, Mazda, Mitsubishi, Nissan, Subaru, Mercedes, Porsche:</u></p> <p>"flag that, once set, remains set as long as the relative weight parameter is not below the unlock threshold for a time"</p>	<p>None required.</p>

The parties agree that the flag is cleared when the relative weight parameter is "below the unlock threshold for a time." Jt. Br., Dkt. 53 at 84-85. Several Defendants argue that once set, the flag remains set unless the relative weight parameter is not below this threshold for a time. *Id.* In effect, these Defendants are arguing that the flag is cleared *only* when the relative weight parameter is below the unlock threshold for a time. Plaintiff argues that this improperly excludes the possibility that the flag can be cleared for other reasons, and proposes that the flag "is cleared when the relative weight parameter is below the unlock threshold for a time." *Id.* at 84-85, 87.

a. The Language of the Claims

Claims 1 and 17 provide a method of and means for inhibiting and allowing air bag deployment. Among the steps are "[setting / set] a lock flag when the relative weight parameter is above the lock threshold and deployment has been allowed for a given time; [establishing / establish] an unlock threshold at a level indicative of an empty seat; [clearing / clear] the flag when the relative weight parameter is below the unlock threshold for a time; and [allowing / allow] deployment while the lock flag is set." '007 Patent at 5:56-64, 8:1-8.

In dependent claims 7 (dependent on claim 1) and 24 (dependent on claim 17), the lock flag is incremented towards a maximum value when the relative weight parameter is above the lock threshold and decremented toward zero when the relative weight parameter is less than the unlock threshold. The lock flag is cleared when the flag value is zero. '007 Patent at 6:40-41, 8:60-63. Plaintiff argues that this creates "a presumption that such specific details are not present in independent claims 1 and 17." Jt. Br., Dkt. 53 at 88. Although this is true as to incrementing and decrementing the flag value, it does not address whether the flag must remain set as long as the relative weight parameter is not below the unlock threshold for a time, which already appears in claims 1 and 17.

UNITED STATES DISTRICT COURT
CENTRAL DISTRICT OF CALIFORNIA

CIVIL MINUTES – GENERAL

Case No. LA CV14-02454 JAK (JEMx) -- AND RELATED CASES

Date April 17, 2015

Title Signal IP v. American Honda Motor Co., Inc. -- AND RELATED CASES

According to the claim language, the flag is “clear[ed] . . . when the relative weight parameter is below the unlock threshold for a time.” ‘007 Patent at 5:62-63, 8:6-7. The claim clearly explains both what the flag is and what it does, indicating that construction is unnecessary.

b. The Specification

According to the abstract, “an allow decision is locked in place as long as total force exceeds a threshold.” ‘007 Patent at Abstract. The specification refers to this as an “Adult Lock Flag.” *Id.* at 4:36. “When the Adult Lock Flag is set, the output decision will always be to allow deployment.” *Id.* at 4:40-41.

Figure 8 of the ‘007 Patent, which is reproduced below, demonstrates how the “Adult Lock Flag” decision is made. *Id.* at 4:36-37. To “set” the flag the total force must be greater than the lock threshold (indicating an adult-occupied seat) and this condition must persist for a certain period of time before the flag value is incremented toward the maximum value. Once the maximum value is reached, a flag “set” command is delivered, ending the cycle. *Id.* at 4:41-50. However, as soon as the total force falls below the unlock threshold (indicating an empty seat), the flag value begins to loop through decrement cycles, decreasing the flag value until zero is reached, then “clearing” the flag. *Id.* at 4:50-57.

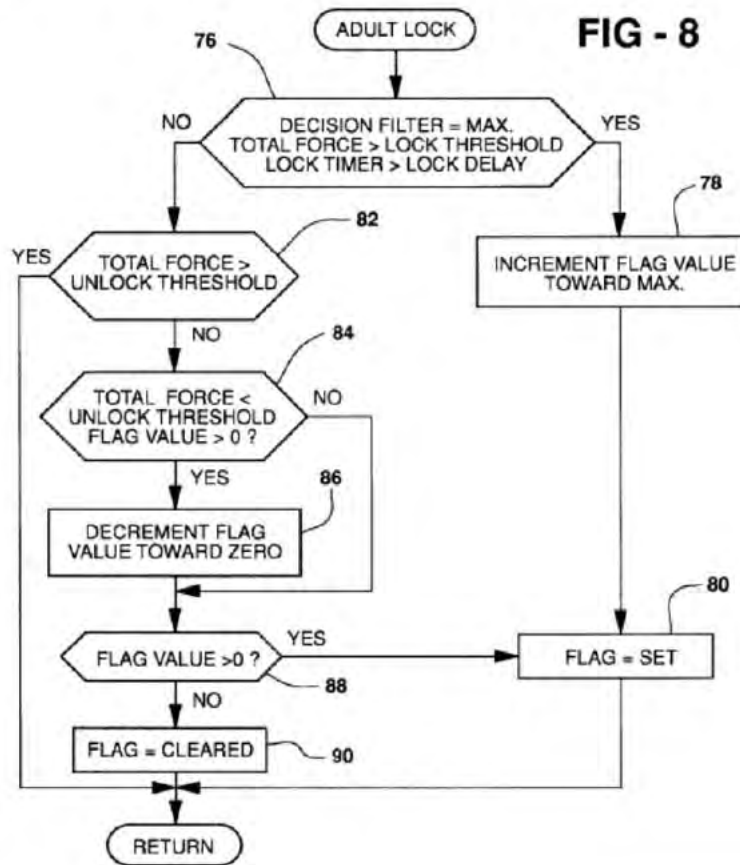

UNITED STATES DISTRICT COURT
CENTRAL DISTRICT OF CALIFORNIA

CIVIL MINUTES – GENERAL

Case No. LA CV14-02454 JAK (JEMx) -- AND RELATED CASES

Date April 17, 2015

Title Signal IP v. American Honda Motor Co., Inc. -- AND RELATED CASES

Plaintiff argues that this is “only ‘a flow chart representing a method of computing an adult lock flag,’ not the *only* method of doing so,” Jt. Br., Dkt. 53 at 88 (quoting ‘007 Patent at 2:35-36), and that Defendants’ effort to import a limitation from the specification onto the claims should be rejected. Indeed, Figure 8 is just an example of using the lock flag, and this limitation should not be imported onto the claims. *Phillips v. AWH Corp.*, 415 F.3d 1303, 1323 (Fed. Cir. 2005) (“although the specification often describes very specific embodiments of the invention, we have repeatedly warned against confining the claims to those embodiments”).

c. The Prosecution History

The prosecution history does not bear on this question.

d. The Extrinsic Evidence

Defendants refer to the dictionary definition for “lock”: “to hold fast . . . ; fix,” *Merriam-Webster’s School Dictionary* 519 (1999), JA-0305. They argue that Plaintiff’s construction is inconsistent with this plain meaning of “lock.” This argument is unconvincing because, even using this definition of lock, something can be locked and then unlocked for different reasons.

e. Conclusion

Because the “lock flag” and how it is cleared are clearly described in the claim, this term does not require construction.

Term No. 14: “For a Time” / “For a Given Time” (Claims 1 & 17)

Plaintiff’s Proposal	Defendant’s Proposal	Court’s Construction
Not indefinite.	<u>VW/ Bentley:</u>	Not indefinite.
Plain and ordinary meaning.	Indefinite.	Construction not required.
To the extent a construction is necessary, Plaintiff proposes: “A time sufficient to avoid the effects of transient events.”		

The parties dispute whether the term is indefinite. VW/Bentley argue that these are terms of degree and no objective bounds are provided in the specification or prosecution history. Jt. Br., Dkt. 53 at 89 (citing *Interval Licensing LLC v. AOL, Inc.*, 766 F.3d 1364 at 1370-71 (Fed. Cir. 2014)). Plaintiff argues that the specification clearly explains that the time should be one sufficient to avoid the effects of transient events, and proposes a construction reflecting that. *Id.* at 88, 91.

UNITED STATES DISTRICT COURT
CENTRAL DISTRICT OF CALIFORNIA

CIVIL MINUTES – GENERAL

Case No.	LA CV14-02454 JAK (JEMx) -- AND RELATED CASES	Date	April 17, 2015
Title	Signal IP v. American Honda Motor Co., Inc. -- AND RELATED CASES		

a. *The Language of the Claims*

In claims 1 and 17, the lock flag is set “when the relative weight parameter is above the lock threshold and deployment has been allowed for a given time.” ‘007 Patent at 5:53-54, 7:65-66. The flag is cleared “when the relative weight parameter is below the unlock threshold for a time.” *Id.* at 5:62-63, 8:6-7. The claims do not specify what constitutes a “given time” or a “time.” In light of the claims, any time would infringe. Therefore, there is no confusion about what times could be within the bounds of these claims, indicating the terms are not indefinite.¹⁴ “In light of *Nautilus*, the Federal Circuit has clarified that claim language employing terms of degree has long been found definite where it provided enough certainty to one of skill in the art when read in the context of the invention.” *NobelBiz, Inc. v. LiveVox, Inc.*, No. 13-CV-1773-YGR, 2015 WL 225223, at *7-*9 (N.D. Cal. Jan. 16, 2015) (holding that “geographic region” is not indefinite).

b. *The Specification*

The specification explains that the main decision algorithm creates “an allow or an inhibit decision, but this decision is preliminary, subject to subsequent filtering to obtain final consent to deployment.” ‘007 Patent at 4:58-61.

The specification gives a detailed example of an appropriate timeframe. Figure 10 of the ‘007 Patent, which is reproduced below, shows the “decision filter” that makes the “final judgment of whether to consent to deployment.” *Id.* at 5:8-9. This uses an “up and down counter starting at zero and having a maximum count of 255.” *Id.* at 5:9-11. The counter is incremented “if an allow decision is made” and decremented “if an inhibit decision is made.” *Id.* at 5:11-13.

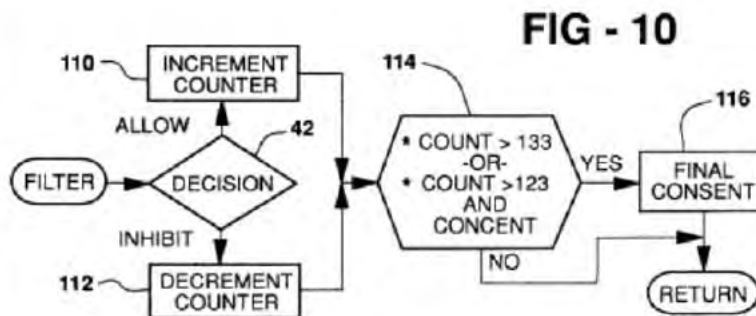

If the count exceeds 133, “consent to deployment is granted.” *Id.* at 5:13-14. The count must remain above 123 “to maintain that state to afford hysteresis,” otherwise “consent is revoked and deployment

¹⁴ In contrast to the term “concentrated” discussed earlier in the context of the ‘375 Patent, there is no confusion about what is within the bounds of these claims. Any time applied would infringe based on the claim language. On the other hand, for the term “concentrated” in the ‘375 Patent, the specification required 100% concentration, but the claims suggested, and Plaintiff argued, that some unspecified smaller percentage would suffice, making it impossible to determine what percentages were within the bounds of “concentrated.” There is no such confusion as to the present issue.

UNITED STATES DISTRICT COURT
CENTRAL DISTRICT OF CALIFORNIA

CIVIL MINUTES – GENERAL

Case No. LA CV14-02454 JAK (JEMx) -- AND RELATED CASES

Date April 17, 2015

Title Signal IP v. American Honda Motor Co., Inc. -- AND RELATED CASES

will be inhibited.” *Id.* at 5:15-18. “Assuming that the increment size is one count, at the 100 ms loop execution rate a minimum of 13.3 seconds will be required to issue the consent, and at least 25.5 seconds are needed to reach the maximum count needed to set the Adult Lock Flag. Similarly, once the maximum count is attained, at least 13.2 seconds are needed to revoke the consent.” *Id.* at 5:18-24.

VW/Bentley argue that this teaching does not provide sufficient precision because “[t]he claimed invention is not limited to this specific example, and the specification does not identify what other time period would fall within the scope of the claims.” *Jt. Br.*, Dkt. 53 at 89. However, the claims are broad enough to encompass any time. Further, the specification shows that the point of the invention is the decision process, not the precise timing of its elements. Thus, the “claims, viewed in light of the specification and prosecution history, inform those skilled in the art about the scope of the invention with reasonable certainty.” *Nautilus*, 134 S.Ct. at 2129.

Plaintiff argues that, if the claim must be construed, it should include the clarification that the “given time” is the time is sufficient to avoid the effects of transient events. *Jt. Br.*, Dkt. 53 at 91. The abstract of the ‘007 Patent explains that “[a]llow and inhibit decisions are filtered [to] avoid sudden response to transient pressure changes on the seat.” This construction would then pose the question of how long is necessary to eliminate transient effects. It is unnecessary to reach that question, as the claims are not so limited.

c. The Prosecution History and the Extrinsic Evidence

The prosecution history and the extrinsic evidence do not bear on this question.

d. Conclusion

There is no uncertainty here as to what amount of time falls within the scope of the claim. Any amount of time will satisfy the condition. It is important to recall the place of this limitation in the claims. For example:

1. In a vehicle restraint system having a controller for deploying air bags and means for selectively allowing deployment according to the outputs of seat sensors responding to the weight of an occupant, a method of allowing deployment according to sensor response including the steps of:
 - determining measures represented by individual sensor outputs and calculating from the sensor outputs a relative weight parameter;
 - establishing a first threshold of the relative weight parameter;
 - allowing deployment when the relative weight parameter is above the first threshold;
 - establishing a lock threshold above the first threshold;
 - setting a lock flag when the relative weight parameter is above the lock threshold and deployment has been allowed **for a given time**;
 - establishing an unlock threshold at a level indicative of an empty seat;
 - clearing the flag when the relative weight parameter is below the unlock threshold **for a time**; and
 - allowing deployment while the lock flag is set.

UNITED STATES DISTRICT COURT
CENTRAL DISTRICT OF CALIFORNIA

CIVIL MINUTES – GENERAL

Case No. LA CV14-02454 JAK (JEMx) -- AND RELATED CASES

Date April 17, 2015

Title Signal IP v. American Honda Motor Co., Inc. -- AND RELATED CASES

A person of ordinary skill in the art would not conclude that they might not be infringing this claim if they performed all of these steps, but used a particularly long or short time. Therefore, the use of the disputed phrase does not prevent a person of ordinary skill in the art from understanding the scope of the invention with reasonable certainty. See *Nautilus*, 134 S. Ct. at 2124. For these reasons, the term is not indefinite, and does not require construction.

Term No. 15: "A Second Threshold" (Claim 20)

Plaintiff's Proposal	Defendant's Proposal	Court's Construction
<p>Not indefinite.</p> <p>Plain and ordinary meaning.</p> <p>To the extent a construction is necessary, Plaintiff proposes: "A second threshold of the relative weight parameter."</p>	<p><u>Honda, Mazda, Mitsubishi, Nissan, Subaru, Mercedes, Porsche:</u></p> <p>Indefinite</p>	<p>Not indefinite</p> <p>"a threshold that differs from the lock threshold, the first threshold, and the unlock threshold"</p>

Several defendants argue that the claim term is indefinite under § 112, paragraph 2 because it is unclear where the "second threshold" must be in relation to other claimed thresholds. *Jt. Br.*, Dkt. 53 at 93. Plaintiff argues that the term is not indefinite, and, to the extent construction is necessary, proposes "a second threshold of the weight parameter." *Id.*

a. The Language of the Claims

Claim 20 depends from claim 17, which refers to several thresholds: "allow deployment when the relative weight parameter is above the first threshold," "establish a lock threshold above the first threshold," and "establish an unlock threshold at a level indicative of an empty seat." '007 Patent at 7:65-67, 8:4-5. The flag is cleared "when the relative weight parameter is below the unlock threshold for a time." *Id.* at 8:6-7.

Claim 20, in its entirety, states: "Means for inhibiting and allowing deployment as defined in claim 17 wherein the microprocessor is further programmed to inhibit deployment when the relative weight parameter is below a second threshold." *Id.* at 8:26-29.

The claims make it clear that the first threshold is used to allow deployment, and the second threshold is used to inhibit deployment. It is not clear from the language of the claims, however, what values are appropriate for these thresholds or how they are calculated.

Given that the claim expressly states "when the relative weight parameter is below a second threshold," Plaintiff's proposed construction is not helpful. See *id.* at 8:28-29.

UNITED STATES DISTRICT COURT
CENTRAL DISTRICT OF CALIFORNIA

CIVIL MINUTES – GENERAL

Case No. LA CV14-02454 JAK (JEMx) -- AND RELATED CASES

Date April 17, 2015

Title Signal IP v. American Honda Motor Co., Inc. -- AND RELATED CASES

b. The Specification

The specification describes several thresholds -- a force threshold, '007 Patent at 3:48-50; a "fixed threshold," *id.* at 3:54, 4:64; a "variable threshold," *id.* at 3:57, 4:63; a "lock threshold," *id.* at 4:42; and an "unlock threshold." *id.* at 4:43-44.

Although the specification does not use the terms "first threshold" or "second threshold," it describes algorithms for determining when allow and inhibit decisions are triggered. An inhibit decision can be made when there is a low total force, *id.* at 4:67-5:2, or "on the basis of the fuzzy measure." *id.* at 5:5-7. Figure 9 of the '007 Patent shows three different scenarios resulting in an inhibit decision, which is reproduced below with the annotations added by Plaintiff. Pl.'s *Markman* Presentation, Dkt. 54 at 60.

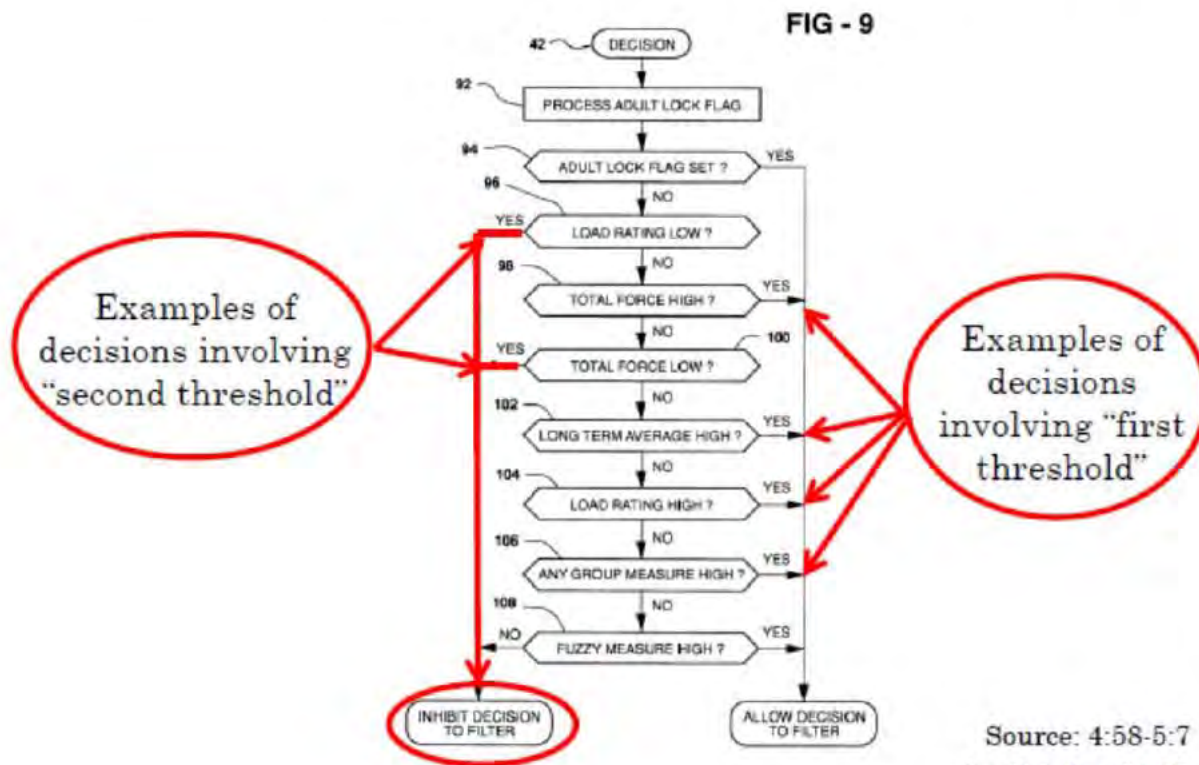

Given that the claim links the "second threshold" to the "inhibit decision," these three criteria represent three possible values of the second threshold. Thus, the claim term is understandable in light of these examples.

According to the Defendants, "[a]ll of the parties agree about where the lock threshold, first threshold, and unlock threshold lie in relationship to one another," Defs.' Presentation Material, Dkt. 66 at 134,

UNITED STATES DISTRICT COURT
CENTRAL DISTRICT OF CALIFORNIA

CIVIL MINUTES – GENERAL

Case No. LA CV14-02454 JAK (JEMx) -- AND RELATED CASES

Date April 17, 2015

Title Signal IP v. American Honda Motor Co., Inc. -- AND RELATED CASES

providing the following figure, and arguing that the patent does not clarify what the “second threshold” is or where it lies in this continuum.

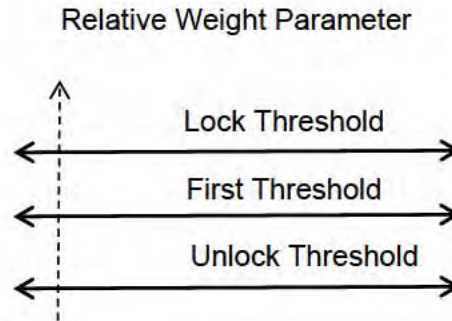

Plaintiff argues that the “second threshold” and “unlock threshold” “apply in different circumstances,” PI.’s Claim Construction Presentation, Dkt. 54 at 61, and provides the following decision tree:

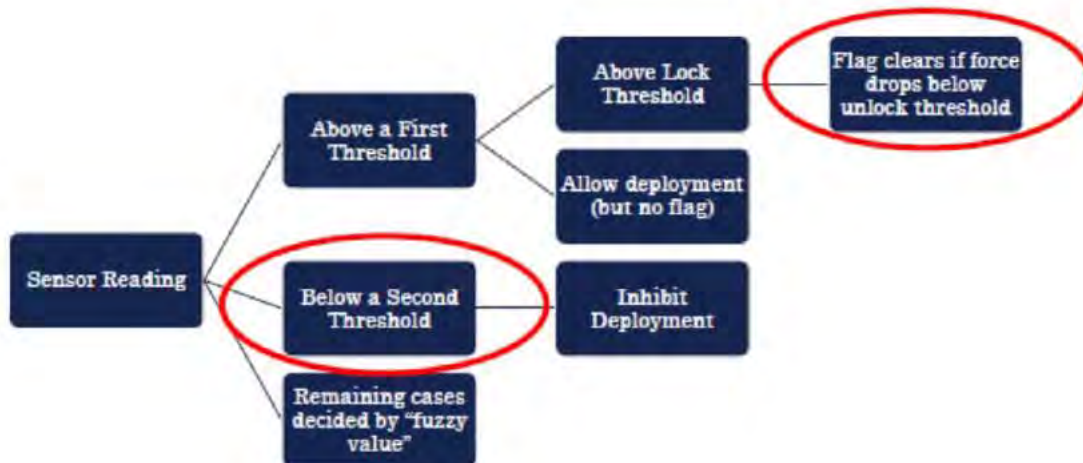

This decision tree implies that the second threshold is lower than the first threshold, but actually does not explain why the second threshold must be lower than the first. Thus, deployment could be allowed if above a threshold and inhibited if below the same threshold. Therefore, in the context of the ‘007 Patent, having a second threshold seems to make sense only if it is in between the “first threshold” and the “unlock threshold.” It would then serve the following purpose:

UNITED STATES DISTRICT COURT
CENTRAL DISTRICT OF CALIFORNIA

CIVIL MINUTES – GENERAL

Case No. LA CV14-02454 JAK (JEMx) -- AND RELATED CASES

Date April 17, 2015

Title Signal IP v. American Honda Motor Co., Inc. -- AND RELATED CASES

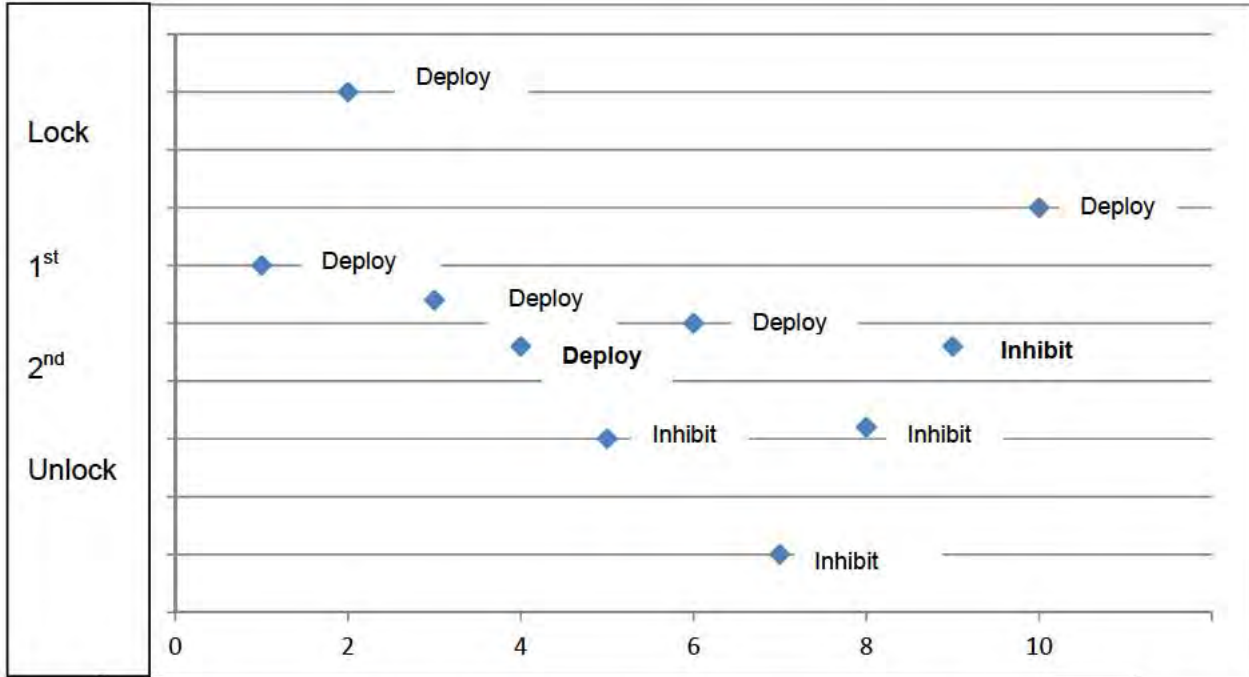

For example, if the system detects a passenger getting into the seat, and the force reaches the first threshold, a deployment condition would be triggered. As the passenger settles in, the force reaches the lock level, and deployment is locked. As the passenger is jostled, the force falls below the first threshold, but deployment is still locked -- that is the purpose of the lock. But when the force falls below the second threshold, an inhibit decision is activated. As the force falls below the unlock threshold, the lock is cleared. Now, as the passenger falls back into the seat, the condition remains inhibited until the force exceeds the first threshold. Thus, in this example, the second threshold causes the 4th and 9th force readings, which are the same, to result in different allow/inhibit decisions.

Ultimately, a detailed understanding of the second threshold is not necessary in determining the bounds of claim 20 -- the claim covers a method using a first threshold, a second threshold, a lock threshold and an unlock threshold. If all four thresholds are not used, the claim is not infringed.

c. The Prosecution History and the Extrinsic Evidence

The prosecution history and extrinsic evidence do not bear on this question.

d. Conclusion

For the foregoing reasons, the term is definite. For clarity, and to ensure that all of the claim terms are given effect, the following construction is adopted: the second threshold is "a threshold that differs from the lock threshold, the first threshold, and the unlock threshold"

UNITED STATES DISTRICT COURT
CENTRAL DISTRICT OF CALIFORNIA

CIVIL MINUTES – GENERAL

Case No. LA CV14-02454 JAK (JEMx) -- AND RELATED CASES

Date April 17, 2015

Title Signal IP v. American Honda Motor Co., Inc. -- AND RELATED CASES

Term No. 16: "Relative Weight Parameter" (Claims 1, 17, 20-22)

Plaintiff's Proposal	Defendant's Proposal	Court's Construction
Not indefinite. Plain and ordinary meaning. To the extent a construction is necessary, Plaintiff proposes: "A relative parameter indicative of weight."	<u>BMW, Mazda, VW/Bentley:</u> Indefinite <u>Honda:</u> Alternatively, "a relative parameter indicative of weight."	Indefinite (Claims 1, 17, 20) Not indefinite (Claims 21, 22) Construction not required.

Several defendants argue that the term "relative weight parameter" is indefinite. They argue that the term is "not used in the specification, and is one of degree," focusing on the use of the word "relative," and its connotations of comparison. *Id.* at 96. Plaintiff disagrees, arguing that the term should not lead to confusion "because the relative weight parameter is simply relative to the threshold." *Id.* at 95-96, 100. To the extent construction is necessary, Plaintiff and Honda (alternatively) propose "a relative parameter indicative of weight." *Id.* at 95-96.

a. *The Language of the Claims*

Claims 1 and 17 describe "determining [/determine] measures represented by individual sensor outputs and calculating [/calculate] from the sensor outputs a relative weight parameter." Then, a "first threshold of the relative weight parameter" is established. '007 Patent at 5:48-52, 7:60-64. Deployment is allowed "when the relative weight parameter is above the first threshold;" a lock flag is set "when the relative weight parameter is above the lock threshold and deployment has been allowed for a given time;" and the flag is cleared "when the relative weight parameter is below the unlock threshold for a time." *Id.* at 5:53-43, 56-58, 62-63; 7:65-66, 8:1-3, 6-7.

Claims 3-6 depend from claim 1. In claim 3, the relative weight parameter "is the total force detected by all the sensors." *Id.* at 6:4-5. In claim 4, the "relative weight parameter is a long term average obtained by the following steps: averaging all sensor outputs over a plurality of sample events to obtain a cumulative average; and long term filtering the cumulative average to obtain the long term average." *Id.* at 6:6-12. In claim 5, "the relative weight parameter is a load rating obtained by: calculating a load rating for each sensor as a function of the difference between the sensor output and a base value; and summing the load rating for all the sensors to derive a total load rating." *Id.* at 6:13-19. In claim 6, "the relative weight parameter is a fuzzy value obtained by: calculating a total load rating for all the sensors; determining a fuzzy load value from the total load rating; calculating a long term average for all the sensors; determining a fuzzy average value from the long term average; and combining the fuzzy average and the fuzzy load value to obtain the fuzzy value." *Id.* at 6:20-29. Claims 21-23 depend from claim 17, and, like claims 3-6, provide detailed embodiments of possible relative weight parameters (the total force, long term average of sensor outputs, and total load rating, respectively). Claim 20 depends from claim 17, but does not give an exemplary relative weight parameter. Rather, in claim 20, "the microprocessor is further programmed to inhibit deployment when the relative weight parameter is

UNITED STATES DISTRICT COURT
CENTRAL DISTRICT OF CALIFORNIA

CIVIL MINUTES – GENERAL

Case No. LA CV14-02454 JAK (JEMx) -- AND RELATED CASES

Date April 17, 2015

Title Signal IP v. American Honda Motor Co., Inc. -- AND RELATED CASES

below a second threshold.” Unlike in claims 21-23, claim 20 does not provide any guidance as to what the “relative weight parameter” is.

Thus, in claims 1, 17, and 20, the boundaries of what might or might not constitute a “relative weight parameter” are unclear.

b. The Specification

The specification does not contain the phrase “relative weight parameter.” The sole reference to a “parameter” is: “A microprocessor is programmed to sample each sensor, determine a total weight parameter by summing the forces, determine the forces on local groups of sensors, and averaging or filtering to provide several different measures of seat occupancy, each of which can be used determine whether to allow deployment.” ‘007 Patent at 2:5-10.

At the *Markman* hearing, Plaintiff argued that Figures 4 and 5 of the ‘007 Patent, which are reproduced below, explain the relative weight parameter. However, as with the rest of the specification, these figures do not mention a “relative weight parameter.” It is possible, in light of Plaintiff’s argument, that the “decision measures” represent possible “relative weight parameters.” However, this is far from clear from the face of the specification, and the extent to which these terms overlap remains unclear.

UNITED STATES DISTRICT COURT
CENTRAL DISTRICT OF CALIFORNIA

CIVIL MINUTES – GENERAL

Case No. LA CV14-02454 JAK (JEMx) -- AND RELATED CASES

Date April 17, 2015

Title Signal IP v. American Honda Motor Co., Inc. -- AND RELATED CASES

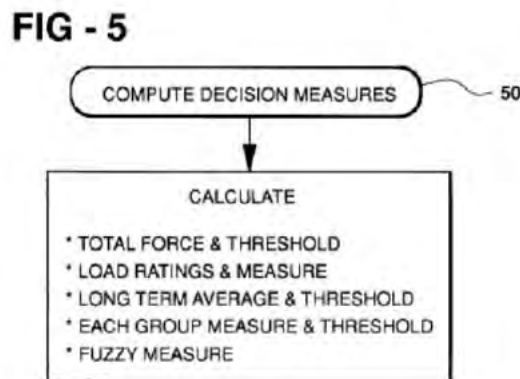
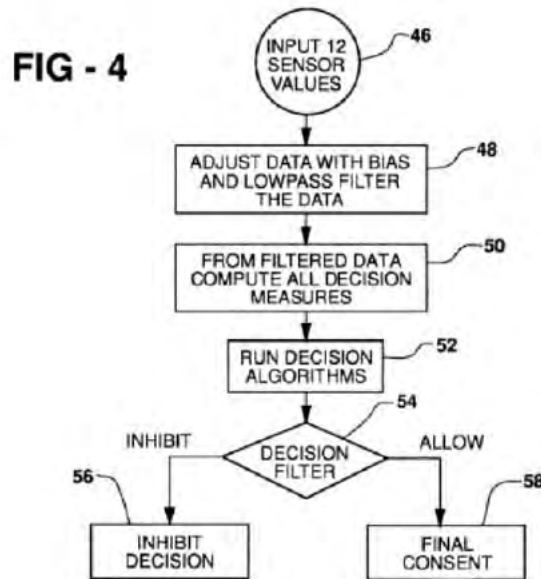

Due to the absence of the word “relative” in the specification, it is unclear whether the relative weight parameter is “relative.” According to Plaintiff, it is relative to the threshold. Plaintiff provides no support for this assertion, and it is not apparent from the specification. Looking at the versions of the relative weight parameter in the dependent claims, none is relative to the threshold. Rather, the threshold is compared to the relative weight parameter after it has been determined. In light of the specification, there is no support for the use of the word “relative.” Further, the specification provides no aid in clarifying the boundaries of “relative weight parameter” in the independent claims.

c. The Prosecution History

The prosecution history does not bear on this question.

UNITED STATES DISTRICT COURT
CENTRAL DISTRICT OF CALIFORNIA

CIVIL MINUTES – GENERAL

Case No. LA CV14-02454 JAK (JEMx) -- AND RELATED CASES

Date April 17, 2015

Title Signal IP v. American Honda Motor Co., Inc. -- AND RELATED CASES

d. The Extrinsic Evidence

The extrinsic evidence does not bear on this question.

e. Conclusion

Because the patent provides no boundaries for what parameters could be considered a “relative weight parameter,” and does not describe to what it is “relative,” a person of ordinary skill in the art would not be able to discern the bounds of the claim with reasonable certainty. For example, an alleged infringer could argue that its product does not infringe, because it simply uses a weight measurement, but not one that is “relative.” Whether such a measurement would infringe cannot be determined with reasonable certainty from the language of the patent.

“If a patentee uses a coined technical term as an element of a claim and fails to clearly define the term elsewhere in the specification or prosecution history, the meaning of the term is left to speculation and subjective judgment. A patent claim, which includes as an element a term, the meaning of which is left to speculation and subjective judgment, is indefinite.” *Acacia Media Techs. Corp. v. New Destiny Internet Group*, 405 F. Supp. 2d 1127, 1134 (N.D. Cal. 2005).

For these reasons, the term is indefinite in claims 1, 17 and 20. However, claims 21 and 22 adequately describe the relative weight parameter, and are not indefinite.¹⁵ Thus, for claims 21 and 22, construction is not necessary.

Term No. 17: “Setting” / “Set a Lock Flag When . . .” (Claims 1, 17)

Plaintiff’s Proposal	Defendant’s Proposal	Court’s Construction
Plain and ordinary meaning.	<u>Honda, Mazda, Mitsubishi, Nissan, Subaru, Mercedes, Porsche:</u> “setting a lock flag only if . . .”	None required.

Several defendants argue that the term should be read to mean that the lock flag is set *only if* certain conditions apply. *Jt. Br.*, Dkt. 53 at 101. Plaintiff simply requests the “plain and ordinary meaning,” arguing that the word “only” should not be read into the claim. *Id.* at 103.

¹⁵ The problem in claims 1 and 17 is cured in the dependent claims that recite a specific parameter. Although the indefiniteness of a term in an independent claim may often result in the indefiniteness of its dependent claims, here, the dependent claims themselves cure the indefiniteness issue. *See Halliburton Energy Servs., Inc. v. M-I LLC*, 514 F.3d 1244, 1250 n.2 (Fed. Cir. 2008) (acknowledging the possibility that a dependent claim may be valid despite a finding of indefiniteness in its independent claim, due to the presence of additional limitations).

UNITED STATES DISTRICT COURT
CENTRAL DISTRICT OF CALIFORNIA

CIVIL MINUTES – GENERAL

Case No. LA CV14-02454 JAK (JEMx) -- AND RELATED CASES

Date April 17, 2015

Title Signal IP v. American Honda Motor Co., Inc. -- AND RELATED CASES

a. *The Language of the Claims*

Claim 1 is to “a method of allowing deployment according to sensor response including the steps of . . . setting a lock flag when the relative weight parameter is above the lock threshold and deployment has been allowed for a given time.” ‘007 Patent at 5:45-47, 57-59.

Claim 17 is to a “means for inhibiting and allowing deployment . . . comprising . . . a microprocessor coupled to the sensor outputs and programmed to . . . set a lock flag when the relative weight parameter is above the lock threshold and deployment has been allowed for a given time.” *Id.* at 7:52-54, 57-58, 8:1-3.

The claims use open-ended language, which includes the words “including” and “comprising.” This means other possibilities are allowed by the claims. Inserting the word “only” would contradict the decision to use open-ended language.

b. *The Specification*

Figure 8 of the ‘007 Patent, which is reproduced below with annotations added, best explains when a lock flag is set.

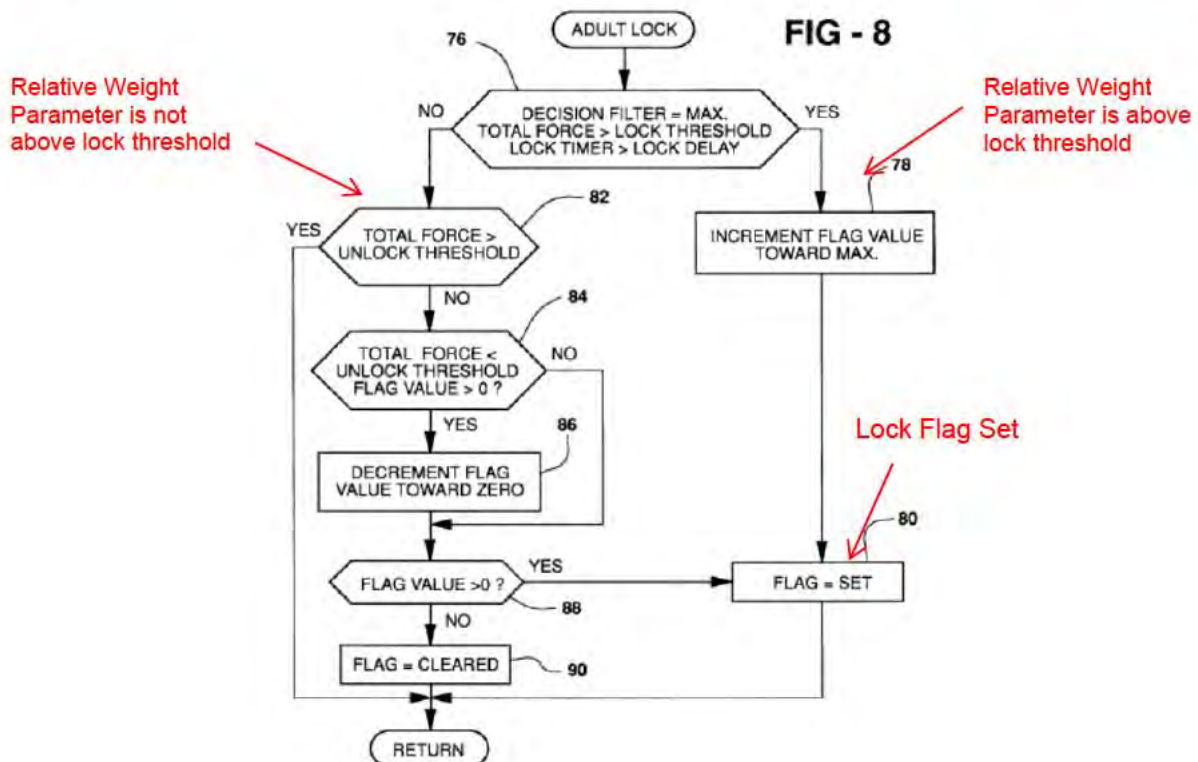

UNITED STATES DISTRICT COURT
CENTRAL DISTRICT OF CALIFORNIA

CIVIL MINUTES – GENERAL

Case No. LA CV14-02454 JAK (JEMx) -- AND RELATED CASES

Date April 17, 2015

Title Signal IP v. American Honda Motor Co., Inc. -- AND RELATED CASES

This flowchart shows two possible routes to setting the lock flag. First, there is a check whether the decision filter is at its maximum value, the total force, i.e. relative weight parameter, is greater than the lock threshold, and the lock timer exceeds the lock delay (box 76). If all these conditions are in place, the flag value is incremented towards a maximum value (box 78). Then, the lock flag is set. *Id.* at 4:46-50. Here, the relative weight parameter is above the lock threshold.

If box 76 results in a “no,” the system checks whether the total force, i.e. relative weight parameter, exceeds the unlock threshold. If not, it checks if the flag value is greater than zero (box 84). If the flag value is greater than zero, the flag value is decremented toward zero (box 86). If, after the decrement, the flag value remains greater than 0 (box 88), the flag is set (box 80). *Id.* at 4:50-57. Here, the relative weight parameter is not above the lock threshold.

For these reasons, the specification discloses more than one set of facts in which the lock flag may be set, and doing so does not necessarily require the relative weight parameter to be above the lock threshold. Thus, it is inaccurate to say the lock flag is set “only if” the relative weight parameter is above the lock threshold . . .”

c. The Prosecution History and the Extrinsic Evidence

The prosecution history and extrinsic evidence do not bear on this question.

d. Conclusion

For the reasons explained above, it is not appropriate to insert the word “only” into this term. Thus, although a system needs to set a lock flag under the conditions described by the claims in order to infringe, that it also sets lock flags under different conditions does not make it noninfringing. As the plain meaning of the term is readily apparent and accurate, construction is not necessary.

Term No. 18: “A Level Indicative of an Empty Seat” (Claims 1, 17)

Plaintiff’s Proposal	Defendant’s Proposal	Court’s Construction
Plain and ordinary meaning. To the extent a construction is necessary, Plaintiff proposes: “A measurement indicative of an empty seat or small occupant.”	<u>Honda, Kia, Mitsubishi, Nissan, Subaru, Mercedes, Porsche:</u> “a force/pressure measurement of zero or substantially zero weight on the seat”	“a force/pressure measurement of zero or substantially zero weight on the seat”

Several defendants argue that the claim term should mean that zero or effectively zero weight is on the seat. Plaintiff argues that the specification supports extending coverage to a weight indicative of a small occupant that is not effectively zero. *Jt. Br.*, Dkt. 53 at 104.

UNITED STATES DISTRICT COURT
CENTRAL DISTRICT OF CALIFORNIA

CIVIL MINUTES – GENERAL

Case No. LA CV14-02454 JAK (JEMx) -- AND RELATED CASES

Date April 17, 2015

Title Signal IP v. American Honda Motor Co., Inc. -- AND RELATED CASES

a. *The Language of the Claims*

In claims 1 and 17, an “unlock threshold” is established “at a level indicative of an empty seat.” ‘007 Patent at 5:59-60, 8:4-5. The claims do not further specify what measurements indicate an empty seat.

Defendants argue that, based on this language, “empty” plainly means that there is zero or effectively zero weight on the seat. Jt. Br., Dkt. 53 at 104. This is a better fit with the plain language of the claims than Plaintiff’s suggestion that “empty” extends to a seat with a small occupant.

Plaintiff argues that other claim language suggests that the claimed force cannot be zero. That is because, in claims 1 and 17, the flag is cleared “when the relative weight parameter is below the unlock threshold for a time.” *Id.* at 106-07. Similarly, in claim 7 the flag value is decremented towards zero “when the relative weight parameter is less than the unlock threshold,” and, in claim 16, the flag is cleared “when the total force is below the unlock threshold for a time.” Based on this language, Plaintiff argues that, if the unlock threshold were set to zero, the flag would only clear when the force is less than zero, which is an impossibility. *Id.*

These values could be less than the unlock threshold if it is set to “substantially zero.” Further, because of the indefiniteness of “relative weight parameter,” it is conceivable that it could have a negative value. Thus, Plaintiff’s argument does not override the plain meaning of an “empty seat.”

b. *The Specification*

According to the specification, it is the object of the invention to “disable the airbag when a small person occupies the seat or when the seat is empty.” ‘007 Patent at 1:28-30. “For example, the system may be tuned to always inhibit deployment for occupants weighing less than 66 pounds, and always allow deployment for occupants exceeding 105 pounds.” *Id.* at 2:58-61. “The algorithm uses a lock threshold which is above the total force threshold range and an unlock threshold which represents an empty seat.” *Id.* at 4:41-44.

The specification repeats the language in the claims that “an unlock threshold . . . represents an empty seat.” *Id.* at 43-44. However, it is an object of the invention to disable the airbag when a small person occupies the seat or when the seat is empty. *Id.* at 1:28-30. An example of always inhibiting deployment for occupants under 66 pounds is provided. *Id.* at 2:58-61. But, the specification distinguishes between a small occupant and an empty seat, *id.* at 1:28-30, 2:55-57, and the claims only use the language “empty seat.” This supports the conclusion that these are two distinct concepts and only the latter is claimed.

The ‘007 Patent is a continuation-in-part of the ‘375 Patent, which it incorporates by reference. In the ‘375 Patent, “[a]n empty seat will have a total force near 0 after the bias adjustments [a minor correction].” ‘375 Patent at 3:53-54. According to Defendants, this clearly requires an “empty seat” to have “a total force near 0.” Jt. Br., Dkt. 53 at 104. Plaintiff argues that the ‘375 Patent does not include the concept of an “unlock threshold,” so its definition of an empty seat should not be used here. *Id.* at

UNITED STATES DISTRICT COURT
CENTRAL DISTRICT OF CALIFORNIA

CIVIL MINUTES – GENERAL

Case No. LA CV14-02454 JAK (JEMx) -- AND RELATED CASES

Date April 17, 2015

Title Signal IP v. American Honda Motor Co., Inc. -- AND RELATED CASES

109. But Plaintiff has not shown why the answer to the question whether empty means zero differs depending on whether an unlock threshold is involved.

c. The Prosecution History

In responding to a rejection based on obviousness in view of the '375 Patent, the applicant responded:

While the Cashler ['375] patent admittedly is foundational to the present invention, the rejected claims recite non-obvious enhancements in the form of apparatus and method steps which are particularly useful for discriminating between heavy and light occupants under dynamic conditions due, for example, to occupant shifting or bouncing. Such enhancements are neither shown nor suggested in Cashler. . . . (3) clearing the lock flag when the total force or relative weight parameter is below an empty seat threshold for a time These steps/functions are not found in Cashler; rather, they enhance Cashler by addressing dynamic operating conditions not even recognized in the Cashler patent."

July 9, 1999 Amendment, SIG00000226. Defendants argue that this shows that the patentee "expressly recognized that the disclosed system differentiated between large occupants, small occupants, and an empty seat but claimed only . . . an empty seat." *Jt. Br.*, Dkt. 53 at 105-06. Plaintiff argues that the applicant emphasized that enhancements for dynamic conditions and heavy and light occupants were "neither shown nor suggested" in the '375 Patent, so the '375 Patent did not contemplate the appropriate "level indicative of an empty seat" for the '007 Patent. *Id.* at 108-09.

Overall, the prosecution history echoes what is stated in the specification. As such it does not provide a helpful basis to determine what value a relative weight parameter must have to be "below an empty seat threshold."

d. The Extrinsic Evidence

The extrinsic evidence does not bear on this question.

e. Conclusion

Although the specification discusses both an "empty seat" and small occupants, the patentee used the phrase "empty seat" in the claim. For this reason Defendants' proposed construction is adopted: "a force/pressure measurement of zero or substantially zero weight on the seat."

UNITED STATES DISTRICT COURT
CENTRAL DISTRICT OF CALIFORNIA

CIVIL MINUTES – GENERAL

Case No. LA CV14-02454 JAK (JEMx) -- AND RELATED CASES

Date April 17, 2015

Title Signal IP v. American Honda Motor Co., Inc. -- AND RELATED CASES

Term No. 19: "Arrayed in an Interface Defined by the Bottom Surface" (Claim 19)

Plaintiff's Proposal	Defendant's Proposal	Court's Construction
Plain and ordinary meaning.	<p><u>Honda, Kia, Mazda, Mitsubishi, Nissan, Subaru, Mercedes, Porsche:</u></p> <p>"an ordered or symmetrical grouping of sensors arranged in rows and columns on the bottom surface of the resilient pad"</p>	None required.

The parties agree that the claim term describes an ordered grouping of sensors, the location of which is on or defined by the bottom surface of the pad. Several defendants argue that this grouping should be "ordered or symmetrical" and "arranged in rows or columns," and that the array must be "on" the bottom surface of the resilient pad. *Jt. Br.*, Dkt. 53 at 109-10. Plaintiff responds that these limitations should not be imposed on the term. *Id.* at 112.

These arguments are the same as those made for term 9, which appeared in the related '375 Patent. There, it was determined that the term "array" is not restricted to a symmetrical grouping of rows and columns. In a similar conclusion regarding term 12 in the '007 Patent, it was determined that the sensors need not be restricted to be in, or on, a seat cushion. Given that the arguments about defining an "array" are based entirely upon material that also appears in the '375 Patent, that decision also applies here. *See* term 9, *supra*. This only leaves the issue whether the sensors must be "on the bottom surface of the resilient pad."

a. The Language of the Claim

In claim 19, "the seat sensors are arrayed in an interface defined by the bottom surface and the panel for sensing forces imposed by the weight of the occupant." '007 Patent at 8:23-25. The claim places the seat sensors on "an interface defined by the bottom surface of the resilient pad." *Id.* The claim itself clearly indicates the position of the sensors.

b. The Specification

The abstract describes "sensors on the bottom surface of a seat cushion." '007 Patent at Abstract. Figure 3 shows the arrangement of sensors:

UNITED STATES DISTRICT COURT
CENTRAL DISTRICT OF CALIFORNIA

CIVIL MINUTES – GENERAL

Case No. LA CV14-02454 JAK (JEMx) -- AND RELATED CASES

Date April 17, 2015

Title Signal IP v. American Honda Motor Co., Inc. -- AND RELATED CASES

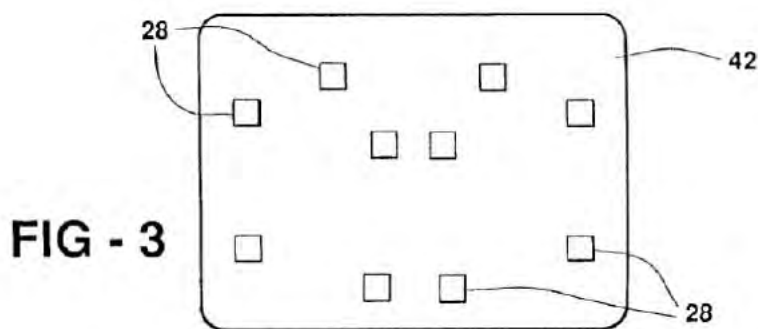

The sensors are “judicially [sic, likely “judiciously”] located in the seat,” and “arranged in groups in the seat.” *Id.* at 1:66, 2:4-5. The sensors are held by the “form” “on its upper surface so that the sensors are pressed against the bottom surface of the seat cushion.” *Id.* at 3:24-27. “The seat structure with sensors placed on the bottom surface of the seat cushion permits sensing of occupant weight without great sensitivity to localized forces on the top surface of the seat.” *Id.* at 5:35-38.

Figure 2 shows “a cross section of a seat equipped with pressure sensors, according to the invention.” It is reproduced below, with annotations added. *Id.* at 2:20-21.

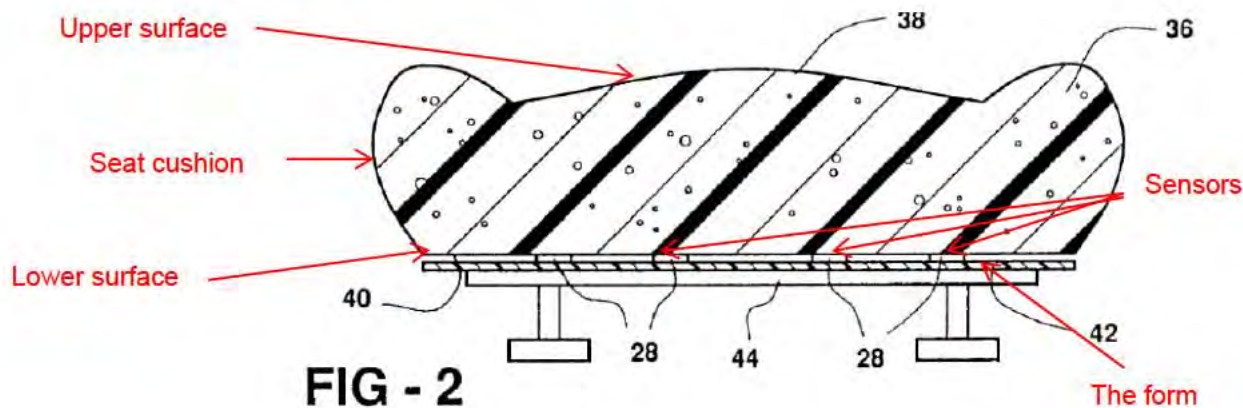

It is not clear from the figure whether the sensors are attached to the seat cushion itself or to the form. Although language in the specification indicates the sensors are in, or on, the resilient pad itself, there is no reason to import these limitations onto the claim. The claim language appears to embrace both these possibilities.

c. *The Prosecution History and the Extrinsic Evidence*

The prosecution history and the extrinsic evidence do not bear on this question.

UNITED STATES DISTRICT COURT
CENTRAL DISTRICT OF CALIFORNIA

CIVIL MINUTES – GENERAL

Case No. LA CV14-02454 JAK (JEMx) -- AND RELATED CASES

Date April 17, 2015

Title Signal IP v. American Honda Motor Co., Inc. -- AND RELATED CASES

d. Conclusion

The claim term does not require construction because there is no support for importing Defendants' proposed limitations on the term, no alternative construction has been proposed and the claim itself is very clear on the issue of how the array is "defined by the bottom surface."

Term No. 20: "Means for Selectively Allowing Deployment According to the Outputs of Seat Sensors Responding to the Weight of an Occupant" (Claim 1)"

Plaintiff's Proposal	Defendant's Proposal	Court's Construction
<p><u>Function:</u> "selectively allowing deployment according to the outputs of seat sensors responding to the weight of an occupant"</p> <p><u>Corresponding Structure:</u> A microprocessor 22, which analyzes the sensor inputs and issues a decision whether to inhibit and allow airbag deployment.</p> <p>To the extent that defendants may contend that structure is in the form of an algorithm, then the corresponding structure is recited in the claim itself in the form of specific steps, and the claim is not subject to § 112, paragraph 6.</p>	<p><u>Honda, Kia, Mazda, Mitsubishi, Nissan, Subaru, Mercedes, and Porsche:</u></p> <p>This term should be construed under § 112, paragraph 6</p> <p><u>Function:</u> "selectively allowing deployment according to the outputs of seat sensors responding to the weight of an occupant"</p> <p><u>Corresponding structure:</u> A microprocessor 22, which analyzes the sensor inputs and issues a decision whether to inhibit and allow airbag deployment based on the algorithms of Figures 4, 5, 6, 8, 9, and 10.</p>	<p>The term is construed under § 112, ¶ 6.</p> <p>The function is "selectively allowing deployment according to the outputs of seat sensors responding to the weight of an occupant."</p> <p>The corresponding structure is "a microprocessor," "a line," and the algorithm provided in Claim 1.</p>

The Parties dispute whether this claim limitation is governed by § 112, paragraph 6. If so, the Parties agree that the function is "selectively allowing deployment according to the outputs of seat sensors responding to the weight of an occupant," and that the microprocessor described in the specification is the corresponding structure. *Jt. Br.*, Dkt. 53 at 113-14. The parties also agree that the function at issue begins by operating on the outputs of the seat sensors, so they are not part of the corresponding structure. Several defendants argue that the corresponding structure must include both the microprocessor and multiple algorithms described in the specification. *Id.* According to Plaintiff, the microprocessor is the only corresponding structure necessary from the specification because the algorithm is already sufficiently explained in the claim itself. *Id.* at 122-22. None of the cases cited by the parties addresses the present situation in which a means-plus-function claim recites steps in an algorithm.

UNITED STATES DISTRICT COURT
CENTRAL DISTRICT OF CALIFORNIA

CIVIL MINUTES – GENERAL

Case No. LA CV14-02454 JAK (JEMx) -- AND RELATED CASES

Date April 17, 2015

Title Signal IP v. American Honda Motor Co., Inc. -- AND RELATED CASES

35 U.S.C. § 112 ¶ 6 provides that a claim limitation may be phrased as “a means or step for performing a specified function without the recital of structure, material, or acts in support thereof.” Claim limitations so drafted “shall be construed to cover the corresponding structure, material, or acts described in the specification and equivalents thereof.” 35 U.S.C. §112 ¶ 6. “The guidelines are straightforward: use of the word ‘means’ creates a rebuttable presumption that the drafter intended to invoke § 112, ¶ 6, while failure to use the word ‘means’ creates a rebuttable presumption that the drafter did not intend the claims to be governed by § 112, ¶ 6.” *Flo Healthcare Solutions, LLC v. Kappos*, 697 F.3d 1367, 1373 (Fed. Cir. 2012). The presumption is overcome when the claim language specifies the exact structure necessary to perform the recited function. *TriMed, Inc. v. Stryker Corp.*, 514 F.3d 1256, 1259-60 (Fed. Cir. 2008).

a. *The Language of the Claims*

Claim 1, in its entirety, is as follows:

In a vehicle restraint system having a controller for deploying air bags and **means for selectively allowing deployment according to the outputs of seat sensors responding to the weight of an occupant**, a method of allowing deployment according to sensor response including the steps of:

- determining measures represented by individual sensor outputs and calculating from the sensor outputs a relative weight parameter;
- establishing a first threshold of the relative weight parameter;
- allowing deployment when the relative weight parameter is above the first threshold;
- establishing a lock threshold above the first threshold;
- setting a lock flag when the relative weight parameter is above the lock threshold and deployment has been allowed for a given time;
- establishing an unlock threshold at a level indicative of an empty seat;
- clearing the flag when the relative weight parameter is below the unlock threshold for a time; and
- allowing deployment while the lock flag is set.

'007 Patent at 5:42-64.

Claim 1 uses the term “means,” which creates a rebuttable presumption that 112 ¶ 6 applies. *Flo Healthcare Solutions*, 697 F.3d at 1373. This presumption is rebutted if the corresponding structure is completely provided in the claim. *TriMed*, 514 F.3d at 1259-60.

Claim 1 separately describes a “means for selectively allowing deployment according to the outputs of seat sensors responding to the weight of an occupant” and a “method” for “allowing deployment according to sensor response.” '007 Patent at 5:42-47. It seems clear from the context of the claim that this “method” is the algorithm that is executed by the microprocessor disclosed in the specification. In a means-plus-function term, “[i]f the function is performed by a general purpose computer or microprocessor, then the specification must also disclose the algorithm that the computer performs to accomplish that function.” *Triton Tech of Tex., LLC v. Nintendo of Am., Inc.*, 753 F.3d 1375, 1378 (Fed. Cir. 2014). Here, the algorithm is disclosed in the claim itself. This is unusual, but appears to comply

UNITED STATES DISTRICT COURT
CENTRAL DISTRICT OF CALIFORNIA

CIVIL MINUTES – GENERAL

Case No. LA CV14-02454 JAK (JEMx) -- AND RELATED CASES

Date April 17, 2015

Title Signal IP v. American Honda Motor Co., Inc. -- AND RELATED CASES

with the rule because the claims are considered “a part” of the specification. *Phillips v. AWH Corp.*, 415 F.3d at 1315.

Claim 17 is similar to claim 1, but specifies that the means further comprises “a microprocessor coupled to the sensor outputs and programmed to inhibit and allow deployment according to sensor response and particularly programmed to determine measures represented by individual sensor outputs and calculate from the sensor outputs the relative weight parameter.”¹⁶ ‘007 Patent at 7:57-62.

b. The Specification

Both parties cite the same part of the specification to provide the corresponding structure: “The microprocessor 22 analyzes the sensor inputs and issues a decision whether to inhibit air bag deployment and the decision is coupled to the microprocessor 16 by a line 32.” ‘007 Patent at 3:4-7. Thus, this structure clearly makes the decision whether to inhibit air bag deployment, and is the corresponding structure. In addition to the microprocessor, the “line 32” is also part of the necessary structure.

Defendants argue that the corresponding structure must also include the “decision whether to inhibit and allow airbag deployment based on the algorithms of Figures 4, 5, 6, 8, 9, and 10.” *Jt. Br.*, Dkt. 53 at 116. However, the claim itself already provides the necessary algorithmic structure. Again, the structure of the claim is unusual, but given that it includes the algorithm it recites, no corresponding structure in the specification needs to be found for that portion of the claim.

In sum, the corresponding structure to the portion of the “means” not already recited in the claim is the “microprocessor” 22 and the “line” 32.

c. The Prosecution History

The prosecution history does not bear on this question.

d. The Extrinsic Evidence

Plaintiff’s expert, Dr. Smedley, opined that “the corresponding structure is recited in the claim itself,” and recited the steps in claim 1. Similarly, Smedley recited steps in other claims and concluded that

¹⁶ Plaintiff argues that, if “the ‘microprocessor’ is what performs the steps in claim 17, then the microprocessor also performs the same steps in claim 1.” *Jt. Br.*, Dkt. 53 at 122. Claims 7 and 10 provide algorithms for “setting the lock flag [with] repetitive loops” and “allowing deployment” using counters. Plaintiff argues that these algorithms “include many specific features that are recited in the dependent claims and therefore are presumed not to be present in the independent claim elements.” *Id.* at 123. This argument is unclear and unpersuasive. First, this is a selective attempt to invoke claim differentiation -- if the presence of algorithms in claims 7 and claim 10 implies they are not present in claim 1, why would the microprocessor of claim 17 be in claim 1? Second, “the judicially developed guide to claim interpretation known as ‘claim differentiation’ cannot override the statute. A means-plus-function limitation is not made open-ended by the presence of another claim specifically claiming the disclosed structure which underlies the means clause or an equivalent of that structure.” *Laitram Corp. v. Rexnord, Inc.*, 939 F.2d 1533, 1538 (Fed. Cir. 1991).

UNITED STATES DISTRICT COURT
CENTRAL DISTRICT OF CALIFORNIA

CIVIL MINUTES – GENERAL

Case No. LA CV14-02454 JAK (JEMx) -- AND RELATED CASES

Date April 17, 2015

Title Signal IP v. American Honda Motor Co., Inc. -- AND RELATED CASES

“the claims themselves connote sufficiently definite structure to a person of ordinary skill in the art.” Smedley Decl. at ¶¶ 11-13, JA-0309-0311. Defendants argue that, in his deposition, Smedley “acknowledged that the main decision algorithm in figure 9 is not the only algorithm needed to perform the recited function.” Jt. Br., Dkt. 53 at 116 n.45 (citing Smedley Decl. 192:6-8, JA-0370). However, Smedley’s answer to that question was: “So the processor performs more functions than just what is described in figure 9, yes.” It is not clear that this testimony reflected agreement with the view that figure 9 corresponded to the claimed function, particularly in light of Smedley’s opinion that the claims themselves recite algorithms.

e. Conclusion

The term is construed under 112 ¶ 6. The parties agree that the function is “selectively allowing deployment according to the outputs of seat sensors responding to the weight of an occupant.” The corresponding structure is “a microprocessor,” “a line” and the algorithm provided in Claim 1.

Term No. 21: “Means for Inhibiting and Allowing Deployment . . .” (Claim 17)

Plaintiff’s Proposal	Defendant’s Proposal	Court’s Construction
<p><u>Function:</u> “inhibiting and allowing deployment according to whether a seat is occupied by a person of at least a minimum weight.”</p> <p><u>Corresponding structure:</u> A microprocessor 22, which analyzes the sensor inputs and issues a decision whether to inhibit and allow airbag deployment.</p> <p>To the extent that defendants may contend that structure is in the form of an algorithm, then the corresponding structure is recited in the claim itself in the form of specific steps and the claim is not subject to § 112, paragraph 6.</p>	<p><u>Honda, Kia, Mazda, Mitsubishi, Nissan, Subaru, Mercedes, Porsche:</u></p> <p>This term should be construed under § 112, paragraph 6</p> <p><u>Function:</u> inhibiting and allowing deployment according to whether a seat is occupied by a person of at least a minimum weight.</p> <p><u>Corresponding structure:</u> Fixed resistors 26 in series with pressure sensors 28 of Figures 1-3 and a microprocessor 22, which analyzes the sensor inputs and issues a decision whether to inhibit and allow airbag deployment based on the algorithms of Figures 4, 5, 6, 8, 9, and 10.</p>	<p>Section 112 ¶ 6 does not apply.</p>

Several defendants contend that this term should be construed under 35 U.S.C. § 112, paragraph 6. To the extent this is true, the parties agree that the corresponding function is “inhibiting and allowing deployment according to whether a seat is occupied by a person of at least a minimum weight.”

UNITED STATES DISTRICT COURT
CENTRAL DISTRICT OF CALIFORNIA

CIVIL MINUTES – GENERAL

Case No. LA CV14-02454 JAK (JEMx) -- AND RELATED CASES

Date April 17, 2015

Title Signal IP v. American Honda Motor Co., Inc. -- AND RELATED CASES

According to these defendants, the corresponding structure includes resistors, pressure sensors, a microprocessor, and several different algorithms. Plaintiff argues that the corresponding structure is just the microprocessor. *Jt. Br.*, Dkt. 53 at 124-25.

a. *The Language of the Claim*

Claim 17, in its entirety, is as follows:

In a vehicle restraint system having a controller for deploying air bags, **means for inhibiting and allowing deployment according to whether a seat is occupied by a person of at least a minimum weight comprising:**

seat sensors responding to the weight of an occupant to produce sensor outputs;
a microprocessor coupled to the sensor outputs and programmed to inhibit and allow deployment according to sensor response and particularly programmed to determine measures represented by individual sensor outputs and calculate from the sensor outputs a relative weight parameter,
establish a first threshold of the relative weight parameter,
allow deployment when the relative weight parameter is above the first threshold,
establish a lock threshold above the first threshold,
set a lock flag when the relative weight parameter is above the lock threshold and deployment has been allowed for a given time,
establish an unlock threshold at a level indicative of an empty seat,
clear the flag when the relative weight parameter is below the unlock threshold for a time, and
allow deployment while the lock flag is set.

'007 Patent at 7:50-8:8.

Claim 17 includes the word “means,” creating a presumption that it is subject to Section 112(6). *Flo Healthcare Solutions*, 697 F.3d at 1373. This presumption is rebutted if the corresponding structure is completely provided in the claim. *TriMed*, 514 F.3d at 1259-60. The presumption is rebutted here, because Claim 17 describes in detail what the means includes: seat sensors and a microprocessor programmed to inhibit and allow deployment according to sensor response, specifying the algorithm.¹⁷

At the *Markman* hearing, Defendants argued that, although the claim recites “sensors,” it remains necessary to look to the specification under § 112, ¶ 6 for further identification of the structure. Given that it has already been determined that “seat sensors” does not require construction, and Defendants did not point to any ambiguities about the meaning of seat sensors other than their position (see term no. 12), this is not a compelling argument. Defendants cited *Laitram* and *Lighting Ballast* for the proposition that the mere presence of structure in the claims does not preclude the applicability of 35 U.S.C. § 112, ¶ 6. In *Laitram*, the means provided in the claims were merely functional, and no corresponding structure was provided in the claims. *Laitram Corp. v. NEC Corp.*, 62 F.3d 1388, 1393

¹⁷ Plaintiff argues that the sensors are not part of the means for performing the claimed function. Because this is not a means-plus-function term, that is immaterial. Moreover, the sensors are clearly part of the claimed structure.

UNITED STATES DISTRICT COURT
CENTRAL DISTRICT OF CALIFORNIA

CIVIL MINUTES – GENERAL

Case No. LA CV14-02454 JAK (JEMx) -- AND RELATED CASES

Date April 17, 2015

Title Signal IP v. American Honda Motor Co., Inc. -- AND RELATED CASES

(Fed. Cir. 1995). Similarly, in *Lighting Ballast*, the claim only recited the function without providing any structure. *Lighting Ballast Control LLC v. Philips Elecs. North Am. Corp.*, 744 F.3d 1272, 1295 (Fed. Cir. 2014); *Lighting Ballast Control, LLC v. Philips Elecs. N. Am. Corp.*, 814 F. Supp. 2d 665 (N.D. Tex. 2011). Thus, both cases involve facts quite different from those present here. The presence of the requisite structure in Claim 17 is strong evidence that § 112, ¶ 6 does not apply.

b. The Specification

The specification provides that the “seat occupant sensing system 14 comprises a microprocessor . . . and a series of voltage dividers. . . . Each voltage divider has a fixed resistor 26 in series with a pressure sensor or variable resistor 28.” ‘007 Patent at 2:61-67. Defendants argue that “Signal . . . fails to overcome the burden because the corresponding structure relating to fixed resistors 26 in series with pressure sensors 28 of Figures 1-3 is . . . not recited in the claim.” Jt. Br., Dkt. 53 at 126. But there is no requirement that to avoid means-plus-function treatment, every structure in the specification related to the claimed function must be included in the claim.

“Sufficient structure exists when the claim language specifies the exact structure that performs the functions in question without need to resort to other portions of the specification or extrinsic evidence for an adequate understanding of the structure.” *TriMed*, 514 F.3d at 1259-60 (Fed. Cir. 2008). It appears that a person of ordinary skill in the art would understand the structure of “seat sensors responding to the weight of an occupant” without need to resort to the specification’s description of fixed resistors in series with pressure sensors. Thus, the claim’s recitation of the complete necessary structure rebuts the presumption that this is a means-plus-function term.

c. The Prosecution History

The prosecution history does not bear on this question.

d. The Extrinsic Evidence

The extrinsic evidence does not bear on this question.

e. Conclusion

The presumption that claim 17 is subject to section 112 ¶ 6 is overcome, because all the necessary structure is recited in the claim. Section 112 ¶ 6 does not apply.

D. The ‘486 Patent¹⁸

The ‘486 Patent was issued to Delphi on August 13, 2002. It discloses a technique for limiting the range of an object sensing system in a vehicle by using the steering angle to limit the range of the system. As a result it avoids false alarms. ‘486 Patent at Abstract. It contains 40 claims, eight of which are asserted

¹⁸ The ‘486 Patent is provided as Exhibit P, JA-0407-13.

UNITED STATES DISTRICT COURT
CENTRAL DISTRICT OF CALIFORNIA

CIVIL MINUTES – GENERAL

Case No. LA CV14-02454 JAK (JEMx) -- AND RELATED CASES

Date April 17, 2015

Title Signal IP v. American Honda Motor Co., Inc. -- AND RELATED CASES

by the Plaintiff. *Jt. Rep.*, Dkt. 35 at 4. The parties request construction of one term. *Jt. Statement*, Dkt. 46 at 18-19.

Figure 1 of the '486 Patent, which is shown below, shows a block diagram of the object-sensing system. It includes a processor, memory subsystem, steering angle sensor, object sensor, front sensor, and alarm:

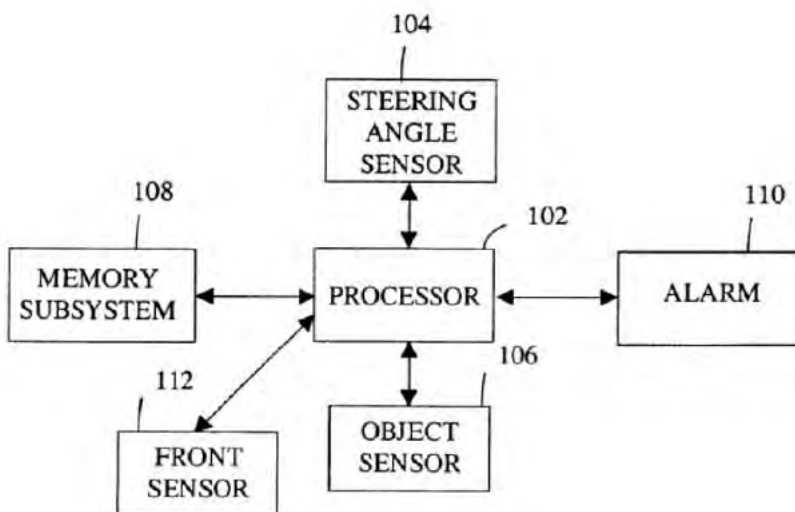

FIG. 1

'486 Patent at 2:46-51. The object sensor can be formed from a combination of radar and/or ultrasonic sensors. *Id.* at 2:99-3:10. The alarm can provide audible and/or visual warnings. *Id.* at 3:30-33.

Figure 2 of the '486 Patent, which is reproduced below, with annotations added, shows the method of calculating the desired warning distance as a function of vehicle position. *Id.* at 3:46-4:18.

UNITED STATES DISTRICT COURT
CENTRAL DISTRICT OF CALIFORNIA

CIVIL MINUTES – GENERAL

Case No. LA CV14-02454 JAK (JEMx) -- AND RELATED CASES

Date April 17, 2015

Title Signal IP v. American Honda Motor Co., Inc. -- AND RELATED CASES

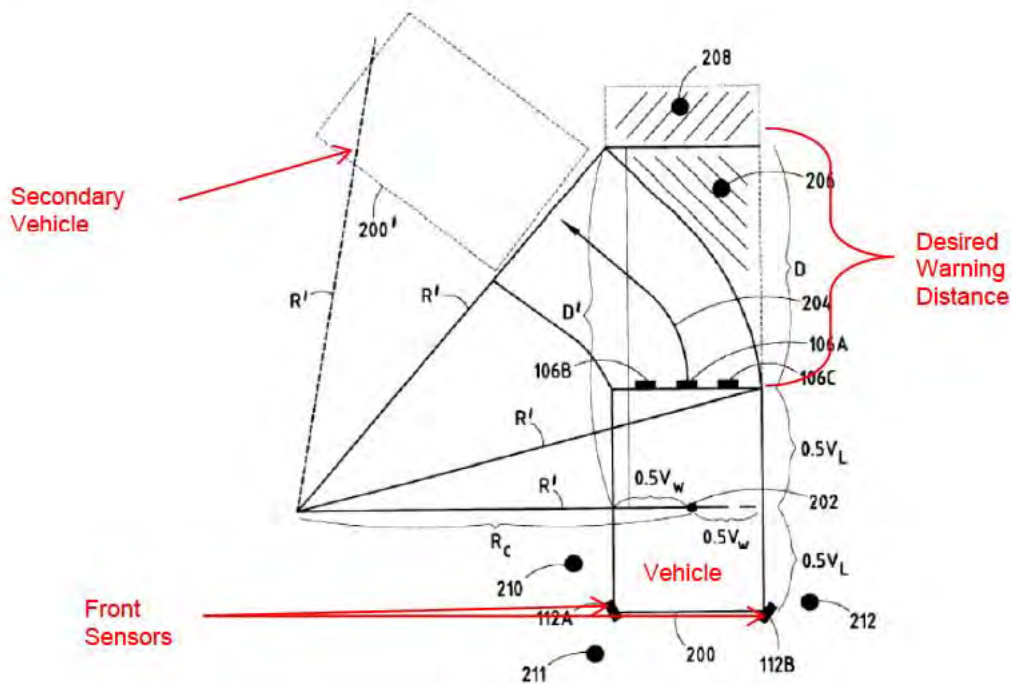

FIG. 2

The specification explains that if the distance to an object exceeds the desired warning distance, an alarm would be a nuisance because the path of the vehicle would not result in a collision with the object. *Id.* at 3:53-57. In Figure 2, the vehicle is shown in a solid origin position and a dotted secondary position, which the vehicle will reach after traveling along a projected path. *Id.* at 3:65-67. The radius of curvature R_c is based on the center of the vehicle, and V_w and V_L measure the width and length of the vehicle, respectively. *Id.* at 3:48-54. The projected path of the vehicle has an outer radius R' , which can be used to calculate the warning distance D as shown below. *Id.* at 3:67-4:18.

UNITED STATES DISTRICT COURT
CENTRAL DISTRICT OF CALIFORNIA

CIVIL MINUTES – GENERAL

Case No. LA CV14-02454 JAK (JEMx) -- AND RELATED CASES

Date April 17, 2015

Title Signal IP v. American Honda Motor Co., Inc. -- AND RELATED CASES

$$R' = \sqrt{\left(R_C + \frac{V_W}{2}\right)^2 + \left(\frac{V_L}{2}\right)^2}$$

$$D' = \sqrt{R'^2 - \left(R_C - \frac{V_W}{2}\right)^2}$$

$$D = D' - \frac{V_L}{2}$$

$$D = \sqrt{2R_C V_W + \frac{V_L^2}{4}} - \frac{V_L}{2}$$

The system may use additional front sensors. *Id.* at 4:32-33. In conjunction with the steering angle (“yaw rate”) sensor, the front sensors, which are shown in Figure 8, can determine if an object to the side of the vehicle poses a threat of a collision. *Id.* at 4:32-36. The yaw rate sensor determines whether the equipped vehicle is traveling toward an object; it cancels the alarm if it is not. *Id.* at 4:37-41. Thus, in Figure 2, the system would ignore object 210, because the front of the vehicle is turning away from it, but would provide an alert for object 212, because the front of the vehicle is turning toward it. *Id.* at 4:38-41.

The asserted '486 Patent claims are reproduced here with the disputed terms in bold:

21. A method for limiting the range of a object sensing system such that certain objects detected by the sensing system that are not in a vehicle path do not cause the sensing system to provide an alarm, comprising the steps of:

- determining a **desired warning distance based upon the current steering angle**;
- determining a current distance to a sensed object; and
- providing an alarm only if the sensed object is within the **desired warning distance**.

28. An object sensing system that provides for limiting the range of the sensing system such that certain objects detected by the sensing system that are not in a vehicle path do not cause the sensing system to provide an alarm, comprising:

- a processor;
- a memory subsystem for storing information coupled to the processor;
- a steering angle sensor coupled to the processor;
- an object sensor coupled to the processor; and
- processor executable code for causing the processor to perform the steps of:
 - determining a **desired warning distance based upon the current steering angle**;
 - determining a current distance to a sensed object as derived from the object sensor; and

UNITED STATES DISTRICT COURT
CENTRAL DISTRICT OF CALIFORNIA

CIVIL MINUTES – GENERAL

Case No. LA CV14-02454 JAK (JEMx) -- AND RELATED CASES

Date April 17, 2015

Title Signal IP v. American Honda Motor Co., Inc. -- AND RELATED CASES

providing an alarm only if the sensed object is within the **desired warning distance**.

Term No. 22: "Warning Distance Based upon the Current Steering Angle"/
"Desired Warning Distance" (Claims 21 & 28)

Plaintiff's Proposal	Defendant's Proposal	Court's Construction
<p>Plain and ordinary meaning.</p> <p>To the extent a construction is necessary, Plaintiff proposes: "Distance that depends on the current steering angle, within which an alarm is provided for a sensed object."</p> <p>(for "desired warning distance based upon the current steering angle")</p>	<p><u>Kia, Mazda, Mitsubishi, Nissan, Subaru, Porsche</u>: "distance that varies depending on the current steering angle, within which an alarm is provided for a sensed object"</p> <p><u>Honda</u>: "a distance within which a sensed object generates a warning that varies based upon instantaneous steering angle"</p> <p><u>BMW</u> (for "desired warning distance"): "a distance that the user or system defines such that all objects sensed at less than that distance result in an alarm"</p> <p><u>Mercedes</u>: no construction necessary.</p>	<p>"warning distance that is a function of the current steering angle," noting that stepwise and other non-linear, or non-square root functions are not excluded.</p>

Several parties propose constructions for the phrase "warning distance based up on the current steering angle," while BMW focuses on "desired warning distance." *Jt. Br.*, Dkt. 53 at 129. This Order considers the longer phrase, which provides helpful context for the subpart on which BMW has focused.

Kia, Mazda, Mitsubishi, Nissan, Subaru, and Porsche argue that the distance must "var[y] depending on the current steering angle." *Id.* Similarly, Honda argues that the desired warning distance is that "within which a sensed object generates a warning that varies based upon instantaneous steering angle." *Id.* at 133. Plaintiff proffers that the "claim language merely requires that the calculation of the warning distance take the current steering angle into account." *Id.* at 137.

On its face, the parties' competing, proposed language is not materially different. Further, the parties agree that the warning distance changes based on the current steering angle. However, Plaintiff argues that the term "varies" is too restrictive, because a slight change in steering angle may not necessarily result in a new warning distance. *Id.* Given their positions, the scope of the present dispute is unclear.

UNITED STATES DISTRICT COURT
CENTRAL DISTRICT OF CALIFORNIA

CIVIL MINUTES – GENERAL

Case No. LA CV14-02454 JAK (JEMx) -- AND RELATED CASES

Date April 17, 2015

Title Signal IP v. American Honda Motor Co., Inc. -- AND RELATED CASES

However, based on Plaintiff's statement, it appears that it seeks to preserve a scope of the claim in which small steering angle changes would not necessarily result in a warning distance change.

On a different element, BMW proposes that the distance is defined by "the user or system" "such that all objects sensed at less than that distance result in an alarm." *Id.* at 129. Plaintiff responds that this construction would result in false alarms from objects that do not pose risk of collisions, and does not accurately portray the system. *Id.* at 138. Plaintiff also argues that warning distance is "determined," which implies computation, not "defined," which "implies a statement of meaning." From this premise, it contends that it would be misleading to say the distance is "defined" by the user or system. *Id.* at 139.

Finally, it appears that the parties are disputing whether the claim's alert criteria are meant in an "only if" or "always if" sense.

a. The Language of the Claims

Claims 21 and 28 provide a system and method "for limiting the range of" a sensing system to avoid false alarms, "comprising" steps that include "determining a desired warning distance based upon the current steering angle." '486 Patent at 6:33-38, 6:58-7:4. An alarm is then provided "only if the sensed object is within the desired warning distance." *Id.* at 6:41-42, 7:8-9. The claims do not require a particular relationship between the current steering angle and the desired warning distance.

Several parties propose adding the phrase "within which an alarm is provided for a sensed object." *Jt. Br.*, Dkt. 53 at 129. Given that the claims already explain that an alarm is provided "only if the sensed object is within the desired warning distance," this proposed addition would be redundant. See '486 Patent at 6:41-42, 7:8-9. "Claim construction . . . is not an obligatory exercise in redundancy." *U.S. Surgical Corp. v. Ethicon, Inc.*, 103 F.3d 1554, 1568 (Fed. Cir. 1997). Alternatively, to the extent that Defendants seek to change this "only if" language in a manner that would mean "always if," they have not justified their position.

Similarly, BMW contends that "all objects" within the desired warning distance result in an alarm. *Jt. Br.*, Dkt. 53 at 134-135. Once again, the claims use the language "only if," not "always if." In these open-ended "comprising" claims, the phrase "only if" allows additional tests to be imposed before the system issues an alarm. BMW also proposes that the construction states that "the user or system defines" the desired warning distance. *Id.* at 129. The claims describe "determining a desired warning distance based upon the current steering angle." '486 Patent at 6:37-38, 7:3-4. It is not clear how substituting BMW's proposed language would make this description more accurate or precise.

b. The Specification

i. Warning Distance and Steering Angle

According to the specification, the "desired warning distance (D) varies depending on the path of the vehicle," *id.* at 3:48-55, as shown in Figure 2 of the '486 Patent, which is reproduced below, with annotations added. "If the actual distance to a given object is greater than (D), then an alarm, if provided, is a nuisance alarm." *Id.* at 3:55-57.

UNITED STATES DISTRICT COURT
CENTRAL DISTRICT OF CALIFORNIA

CIVIL MINUTES – GENERAL

Case No. LA CV14-02454 JAK (JEMx) -- AND RELATED CASES

Date April 17, 2015

Title Signal IP v. American Honda Motor Co., Inc. -- AND RELATED CASES

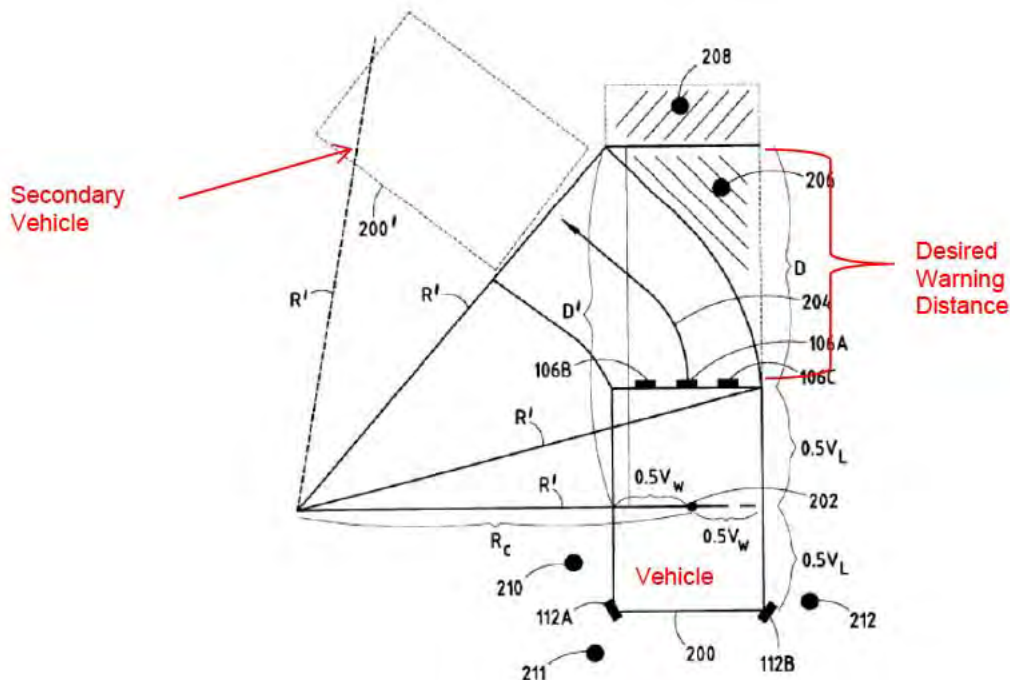

FIG. 2

The specification explains how the desired warning distance is calculated in “the preferred embodiment.” *Id.* at 3:30. The desired warning distance is calculated using the variables: R_C (radius of curvature), V_W (vehicle width), and V_L (vehicle length), illustrated in Figure 2, above. *Id.* at 3:48-54.

The radius of curvature (R_C) is “based on a center 202 of vehicle 200,” *id.* at 3:48-49, and “can be determined by, for example, steering angle sensors or yaw rate sensors.” *Id.* at 2:34-36. “As is well understood by one of ordinary skill in the art, a steering angle sensor is typically positioned on a steering column of a vehicle so as to provide an indicator of the current steering angle.” *Id.* at 2:38-41.

As shown below, the projected path of the vehicle has an outer radius R' , which can be used to calculate the warning distance D . *Id.* at 3:67-4:18.

UNITED STATES DISTRICT COURT
CENTRAL DISTRICT OF CALIFORNIA

CIVIL MINUTES – GENERAL

Case No. LA CV14-02454 JAK (JEMx) -- AND RELATED CASES

Date April 17, 2015

Title Signal IP v. American Honda Motor Co., Inc. -- AND RELATED CASES

$$R' = \sqrt{\left(R_C + \frac{V_W}{2}\right)^2 + \left(\frac{V_L}{2}\right)^2}$$

$$D' = \sqrt{R'^2 - \left(R_C - \frac{V_W}{2}\right)^2}$$

$$D = D' - \frac{V_L}{2}$$

$$D = \sqrt{2R_C V_W + \frac{V_L^2}{4}} - \frac{V_L}{2}$$

These formulas demonstrate that the steering angle may be used to determine the radius of curvature (R_C) upon which the warning distance (D) function relies. But, the dispute between Kia and Plaintiff arises from the use of the word “varies” in the claim term. Kia and several other defendants argue that the term should be construed as “distance that varies depending on the current steering angle . . .” Jt. Br., Dkt. 53 at 129. Kia explains that the ‘486 Patent “expressly describes that the desired warning distance changes with respect to vehicle path, and that vehicle path is determinable from the current steering angle.” *Id.* at 130. The ‘486 Patent does include this statement. ‘486 Patent at Abstract. Similarly, Honda argues that the intrinsic and extrinsic evidence support its construction of “a distance within which a sensed object generates a warning that varies based upon instantaneous steering angle.” Jt. Br., Dkt. 53 at 134.

The specification does not exclude, for example, using a stepped/quantized relationship between steering angle and distance, such that changes are only made at each full degree, or some other fixed increment. For this reason, the specification does not exclude relationships between steering angle and distance that are not perfectly continuous.

ii. Alarm Response and Distance Setting

With regard to BMW’s argument, nothing in the specification supports construing the claims to have “the user or system define[]” the warning distance. *See id.* at 129. BMW also argues that all objects within the desired warning distance must result in an alarm because “the patent does not teach any circumstances in which an alarm is not provided when an object is sensed within the desired warning distance.” *Id.* at 133. However, the ‘486 Patent does not teach that an alarm should always occur. Specifically, Plaintiff points out that there “is no basis anywhere in the evidence to require that all objects that are sensed result in an alarm” -- for example, raindrops and insects should not issue an alarm. *Id.* at 137.

The specification provides that “there are frequently objects (e.g., bicycles, tricycles, another vehicle, etc.) at the rear of the vehicle, within the range of the sensors of the BUA [back up aid], that are not in the path of the vehicle. These objects can cause the BUA to provide a nuisance alarm. To prevent

UNITED STATES DISTRICT COURT
CENTRAL DISTRICT OF CALIFORNIA

CIVIL MINUTES – GENERAL

Case No. LA CV14-02454 JAK (JEMx) -- AND RELATED CASES

Date April 17, 2015

Title Signal IP v. American Honda Motor Co., Inc. -- AND RELATED CASES

certain objects from providing nuisance alarms, the effective range of the BUA is limited.” ‘486 Patent at 2:24-30. This does not suggest that the presence of insects should cause an alarm to issue. Further, the claims are written in “only if” format, and do not require an alarm to be issued. Instead, they require that an alarm not issue if the object is outside of the warning distance.

c. The Prosecution History

Originally, the application resulting in the ‘486 Patent had 20 claims. Claims 21 and 28 were added in the course of prosecution, as original (and current) claims 1 and 8, but without the step of “determining a projected path of a vehicle based upon a current steering angle of the vehicle” / “determining a projected path of a vehicle using a current steering angle of the vehicle as derived from the steering angle sensor.” See Claims as of August 28, 2000, SIG00000774-75 *c.f.* ‘486 Patent Claims 1, 8, 21, 28.

In an April 6, 2001 office action, the USPTO rejected original claims 1 and 8 as anticipated by U.S. Patent No. 6,170,591 to Sakai et al. (“Sakai”). SIG00000791. Sakai discloses “an automatic steering operation . . . carried out on the basis of a relation between a traveling distance of the vehicle stored in advance and a reference steering angle.” Sakai at Abstract, SIG00000798.

In a July 6, 2001 response, the applicant argued that, unlike the present invention, Sakai does not determine “a desired warning distance based upon a current steering angle.” July 6, 2001 Response to Office Action at 2, SIG00000945. “Sakai does not teach or suggest determining a desired warning distance based upon the current steering angle and providing an alarm only if the sensed object is within the desired warning distance.” *Id.* at 3, SIG00000946. Rather, Sakai teaches “providing an alarm when the distance between the vehicle and the obstacle is less than a predetermined amount.” *Id.*

Kia argues that, [i]n distinguishing that prior art, the applicant explicitly disclaimed a system wherein warning distance did not specifically vary as ‘a function of a current steering angle.” Jt. Br., Dkt. 53 at 131. Indeed, the applicant disclaimed a system where a desired warning distance is not based on a current steering angle, but did not make any statements supporting the use of the word “vary.” As a result, to the extent this dispute is about the nature of the continuous relationship between steering angle and warning distance, this portion of the prosecution history is not material or helpful to its resolution.

In response to a final Office Action rejecting the claims, applicants filed a request for reconsideration. Aug. 16, 2001 Request for Reconsideration, SIG00000963. As Honda notes, the applicant distinguished the present invention from the prior art for its use of a warning distance as “a function of the current steering angle.” Jt. Br., Dkt. 53 at 134; Aug. 16, 2001 Office Action at 2, SIG00000964. Again, this does not further specify the parameters of that function.

In an appeal before the Board of Patent Appeals and Interferences, the applicant argued that the rejection of claims 1 and 8 was improper because the “desired warning distance varies depending upon a path of the vehicle” and “upon a current steering angle,” and provides “an alarm only if the sensed object is within the desired warning distance.” Feb. 19, 2002 Appeal Brief, SIG00000976-77. In contrast, Sakai does not use the current steering angle. *Id.*

UNITED STATES DISTRICT COURT
CENTRAL DISTRICT OF CALIFORNIA

CIVIL MINUTES – GENERAL

Case No. LA CV14-02454 JAK (JEMx) -- AND RELATED CASES

Date April 17, 2015

Title Signal IP v. American Honda Motor Co., Inc. -- AND RELATED CASES

In a May 24, 2002 amendment, the applicant deleted the step of “determining a projected path of a vehicle based upon a current steering angle . . .” from claims 21 and 28, arguing that “the deleted step appears to be superfluous.” SIG00000999. As the applicant explained, “the step of determining a projected path of a vehicle based on the current steering angle of the vehicle is actually, in the specific embodiment described in the application, a part of the process (that is a sub-step) of determining a desired warning distance based upon the current steering angle.” *Id.*

Kia argues that this amendment requires a finding that the desired warning distance varies according to the current steering angle. *Jt. Br.*, Dkt. 53 at 131. But, this amendment only says that the projected path of the vehicle is based on the current steering angle and a part of that desired warning distance calculation. It also emphasizes that the warning distance depends upon the steering angle. Again, this does not further delimit the precise manner in which the warning distance depends on the steering angle.

When considered as a whole, the prosecution history reflects an emphasis on an aspect of the specification implicit in the claims -- that changes in steering angle result in changes to warning distance. The prosecution history does not address whether these changes can be stepwise or otherwise specify the precise relationship between angle and distance.

d. The Extrinsic Evidence

Honda refers to a dictionary definition of “current”: “occurring in or belonging to the present time.” *Id.* at 133 (quoting *Webster’s Third New International Dictionary* 557 (2002), JA-0417). Honda argues that this “makes it clear that the ‘current steering angle’ of the vehicle . . . occurs at a specific instant in time.” *Id.* Accordingly, this merits the insertion of the word “instantaneous” into the term. *Id.*

“Current” is a commonly understood word, and there is no basis for replacing it with a synonym. To the extent Honda’s proposal contemplates perfectly instantaneous transmission and processing, it is also unpersuasive. *See, e.g., Paragon Solutions, LLC v. Timex Corp.*, 566 F.3d 1075, 1088 (Fed. Cir. 2009) (holding that “‘displaying real-time data’ cannot possibly mean displaying data literally instantaneously, because the claims themselves require a transmission that necessarily takes some time, however minute that might be”).

e. Conclusion

The term “desired warning distance based upon the current steering angle” is construed to mean “warning distance that is a function of the current steering angle,” noting that stepwise and other non-linear, or non-square root functions, are not excluded.

UNITED STATES DISTRICT COURT
CENTRAL DISTRICT OF CALIFORNIA

CIVIL MINUTES – GENERAL

Case No. LA CV14-02454 JAK (JEMx) -- AND RELATED CASES

Date April 17, 2015

Title Signal IP v. American Honda Motor Co., Inc. -- AND RELATED CASES

E. The '601 Patent¹⁹

The '601 Patent was issued to assignee Delphi on August 10, 2004. It discloses a system and method for controlling propulsion in a hybrid vehicle by switching between different sources of propulsion power at appropriate times. '601 Patent at Abstract. It contains 17 claims, seven of which are asserted by Plaintiff. Jt. Report, Dkt. 35 at 4. The Parties request construction of six terms, two of which Defendants argue are indefinite. Jt. Statement, Dkt. 46 at 20-29.

The invention is for use in "parallel-hybrids." These are vehicles in which power may be selected from one of at least two power systems. '601 Patent at 4:9-13. Figure 1 of the '601 Patent, which is reproduced below, shows the system, comprising a controller, an electric traction motor and a propulsion unit. *Id.* at 2:52-56. The propulsion unit would typically be an internal combustion engine, but could also be a fuel cell. *Id.* at 3:6-11.

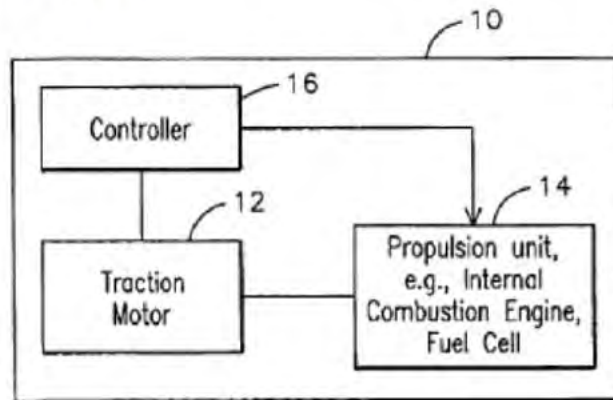

In the prior art, an internal combustion engine ("ICE") and an electric traction motor would generally be used simultaneously to provide additional power, but would compromise the level of fuel consumption in the process. *Id.* at 1:36-38. The '601 Patent states that it improves upon this concept by switching between propulsion methods to optimize fuel efficiency. *Id.* at 1:10-35, 1:50-55.

The object of the invention is to modulate the use of an electric motor or propulsion unit within a vehicle to obtain superior fuel economy. *Id.* at 3:64-67. The vehicle's controller ascertains when the propulsion unit would operate at low efficiency. It does so based on cues including vehicle torque demand, and then switches to the electric motor at these times. *Id.* at 4:30-36.

A sensor, which can be coupled to the accelerator pedal, is used to determine vehicle torque demand. *Id.* at 4:49-51. If the accelerator pedal is fully depressed, the system would recognize that the driver seeks more torque and that electric traction would not be desirable; if the accelerator is partially depressed, then electric traction would be appropriate. *Id.* at 4:49-55.

¹⁹ The '601 Patent is provided as Exhibit R, JA-0418-25.

UNITED STATES DISTRICT COURT
CENTRAL DISTRICT OF CALIFORNIA

CIVIL MINUTES – GENERAL

Case No. LA CV14-02454 JAK (JEMx) -- AND RELATED CASES

Date April 17, 2015

Title Signal IP v. American Honda Motor Co., Inc. -- AND RELATED CASES

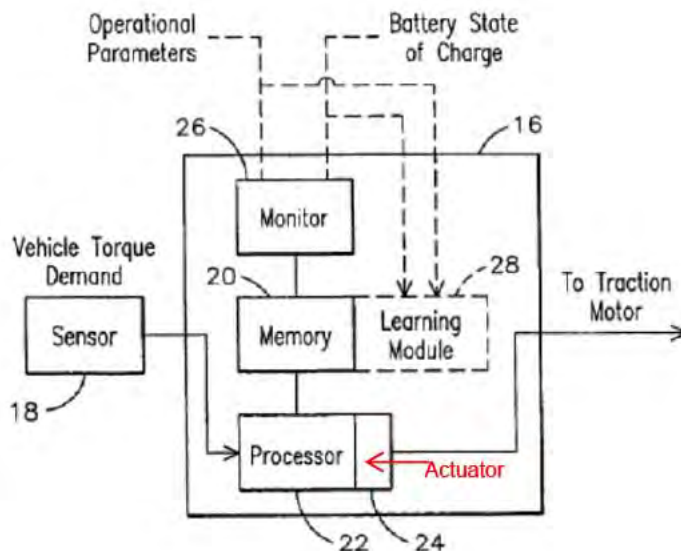

FIG. 2

An exemplar of the embodiment of the controller is shown in Figure 2 of the '601 Patent, which is reproduced above. *Id.* at 2:58-59. The sensor transmits vehicle torque demand information. *Id.* at 4:47-49. A memory stores a threshold torque range, which then sets what the system considers a low vehicle torque demand. The example given is 0-55 Nm. *Id.* at 4:47-61.

A processor determines whether the vehicle torque demand is within the threshold torque range. *Id.* at 4:61-64. When there is torque within the threshold range, an actuator signals the electric traction motor to engage and the propulsion unit to disengage. *Id.* at 4:64-5:2. When the torque is outside of the threshold torque range, the actuator signals the electric traction motor to disengage and the internal combustion engine to engage. *Id.* at 5:2-9.

The controller may also use another option, which includes a monitor and/or learning module. *Id.* at 5:19-25. The monitor option allows the controller to consider additional parameters that reflect environmental or operational conditions. These include charge state and temperature. *Id.* at 5:11-19. The learning option employs a module to collect and analyze historical data of propulsion system performance in order to select an appropriate threshold torque range based on that data. *Id.* at 5:20-25.

Regions of relatively high and low efficiency may be mapped in an efficiency chart, *id.* at 7:8-10. The results may depend on altitude, temperature and other parameters. *Id.* at 6:48-54. The specification incorporates by reference an article by C.C. Chan, which provides such an efficiency map for an internal combustion engine ("ICE"). *Id.* at 4:19-25; C.C. Chan, *The State of the Art of Electric and Hybrid Vehicles* ("Chan"), JA-0618.

UNITED STATES DISTRICT COURT
CENTRAL DISTRICT OF CALIFORNIA

CIVIL MINUTES – GENERAL

Case No. LA CV14-02454 JAK (JEMx) -- AND RELATED CASES

Date April 17, 2015

Title Signal IP v. American Honda Motor Co., Inc. -- AND RELATED CASES

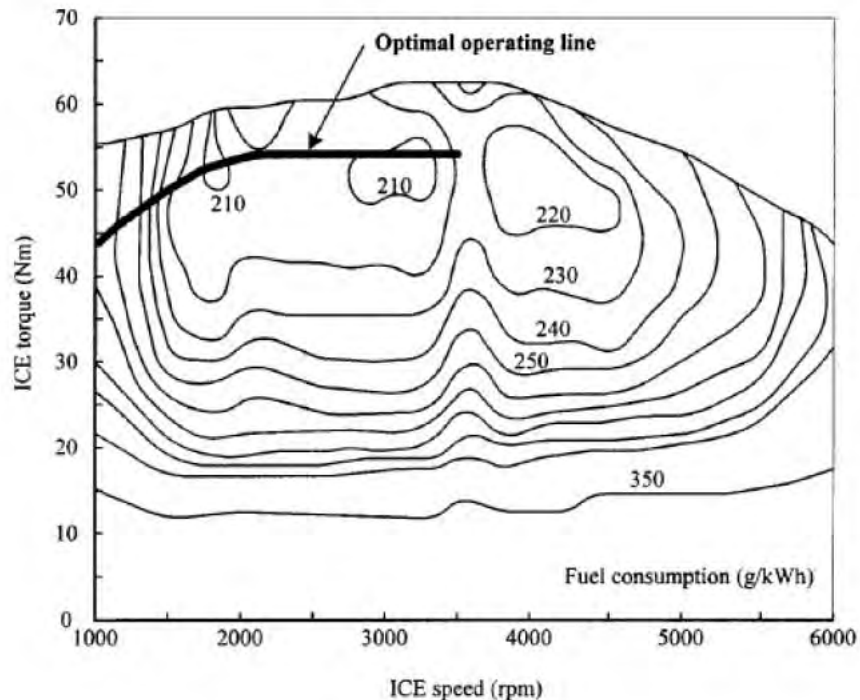

Chan Figure 18

The invention can be embodied in a computer-implemented process wherein segment code -- a computer program code -- is loaded onto a computer. *Id.* at 7:39-48.

The asserted claims of the '601 Patent are reproduced below with the disputed terms in bold.

8. A control system for controlling propulsion equipment in a hybrid vehicle including a traction motor and an internal combustion engine, the control system comprising:
- a sensor coupled to sense a signal indicative of vehicle torque demand;
 - memory for storing a **threshold torque range indicative of conditions of relatively low vehicle torque demand**;
 - a processor configured to process the signal indicative of vehicle torque demand to determine whether the vehicle torque demand is within the **threshold torque range**;
 - during conditions when the signal indicative of vehicle torque demand is within threshold torque range, an actuator configured to generate a signal configured to activate the electric traction motor to drivingly propel the vehicle while de-engaging the internal combustion engine from propelling the vehicle**; and
 - during conditions when the signal indicative of vehicle torque demand is outside the threshold torque range, the actuator configured to generate a signal configured to deactivate the electric traction motor from drivingly propelling the vehicle while re-engaging the internal combustion engine to propel the vehicle.**

UNITED STATES DISTRICT COURT
CENTRAL DISTRICT OF CALIFORNIA

CIVIL MINUTES – GENERAL

Case No. LA CV14-02454 JAK (JEMx) -- AND RELATED CASES

Date April 17, 2015

Title Signal IP v. American Honda Motor Co., Inc. -- AND RELATED CASES

15. A method for controlling a propulsion system in a hybrid vehicle including a traction motor and a propulsion unit, the method comprising:
mapping respective regions of relatively high and low efficiency in an efficiency map for the propulsion unit;
 sensing a signal indicative of said **regions of relatively high and low efficiency;**
during conditions when the sensed signal indicates a region of low-efficiency for the propulsion unit, generating a signal configured to activate the electric motor to drivingly propel the vehicle while de-engaging the propulsion unit from propelling the vehicle; and
during conditions when the sensed signal indicates a region of high-efficiency for the propulsion unit, generating a signal configured to deactivate the traction motor from drivingly propelling the vehicle while re-engaging the propulsion unit to propel the vehicle.

17. A computer-readable medium including computer-readable code for causing a computer to control a propulsion system in a hybrid vehicle including a traction motor and a propulsion unit, the computer-readable medium comprising:
 segment code for **mapping respective regions of relatively high and low efficiency in an efficiency map for the propulsion unit;**
 segment code for sensing a signal indicative of said **regions of relatively high and low efficiency;**
 during conditions when the sensed signal indicates a **region of low-efficiency** for the propulsion unit, segment code for **generating a signal configured to activate the electric traction motor to drivingly propel the vehicle while de-engaging the propulsion unit from propelling the vehicle;** and
 during conditions when the sensed signal indicates a **region of high-efficiency** for the propulsion unit, **segment code for generating a signal configured to deactivate the electric traction motor from drivingly propelling the vehicle while re-engaging the propulsion unit to propel the vehicle.**

Term Nos. 23 & 25: [Listed in Chart Below]

Claim Language	Parties' Proposals	Court's Construction
<p><u>Term No. 23:</u></p> <p>(a) "during conditions when the signal indicative of vehicle torque demand is [within / outside] the threshold torque range, [an / the] actuator configured to generate a signal configured to [activate / deactivate] the electric traction motor [to / from] drivingly</p>	<p><u>Plaintiff and Porsche</u></p> <p>Plain and ordinary meaning for term nos. 23 and 25.</p> <p><u>Honda, Kia, Nissan, Subaru, Mercedes</u></p> <p><u>For Term No. 23:</u></p>	<p>Not necessary.</p>

UNITED STATES DISTRICT COURT
CENTRAL DISTRICT OF CALIFORNIA

CIVIL MINUTES – GENERAL

Case No. LA CV14-02454 JAK (JEMx) -- AND RELATED CASES

Date April 17, 2015

Title Signal IP v. American Honda Motor Co., Inc. -- AND RELATED CASES

<p>propel[ling] the vehicle while [de-engaging / re-engaging] the internal combustion engine [to / from] propel[ling] the vehicle” (claim 8)</p> <p>(b) “during conditions when the sensed signal indicates a region of [low / high]-efficiency for the propulsion unit, generating a signal configured to [activate / deactivate] the electric traction motor [to / from] drivingly propel[ling] the vehicle while [de-engaging / re-engaging] the propulsion unit [to / from] propel[ling] the vehicle” (Claim 15)</p> <p><u>Term No. 25</u></p> <p>(a) “[de-/re-]engaging the [internal combustion engine / propulsion unit] [from propelling / to propel] the vehicle” (Claims 8, 15, 17)</p> <p>(b) “an actuator configured to generate a signal configured to [activate/deactivate] the electric traction motor” (Claim 8)</p> <p>(c) “generating a signal configured to [activate/deactivate] the electric traction motor” (Claims 15, 17)</p>	<p>“during conditions when the signal indicative of vehicle torque demand is [within/outside] the threshold torque range, an actuator configured to always generate a signal configured to [activate/deactivate] the electric traction motor to drivingly propel the vehicle while [de-engaging/re-engaging] the internal combustion engine [from propelling/ to propel] the vehicle” (for (a))²⁰</p> <p>“during conditions when the sensed signal indicates a region of [low/high]-efficiency for the propulsion unit, generating a signal configured to always [activate/deactivate] the electric traction motor to drivingly propel the vehicle while [de-engaging/re-engaging] the propulsion unit [from propelling/to propel] the vehicle.” (for (b))²¹</p> <p><u>For Term No. 25:</u></p> <p>(a) “[de-engaging/re-engaging] the use of the [internal combustion engine/ propulsion unit] [from propelling/to propel] the vehicle in response to the claimed signal”</p> <p>(b) “[activating/deactivating] the use of the electric traction motor in response to the claimed signal generated by the actuator”</p> <p>(c) “[activating/deactivating] the use of the electric traction motor in response to the claimed signal”</p>	
---	---	--

²⁰ Defendants call these terms (i) and (ii).

²¹ Defendants call these terms (iii) and (iv).

UNITED STATES DISTRICT COURT
CENTRAL DISTRICT OF CALIFORNIA

CIVIL MINUTES – GENERAL

Case No. LA CV14-02454 JAK (JEMx) -- AND RELATED CASES

Date April 17, 2015

Title Signal IP v. American Honda Motor Co., Inc. -- AND RELATED CASES

With respect to term no. 23, several defendants propose adding the word “always” to four lengthy claim terms. Jt. Br., Dkt. 53 at 139. Without proposing a construction, Plaintiff argues that there is no support in the intrinsic evidence for this restriction. *Id.* The language used is unclear, but the briefing shows that the dispute concerning term 23 is whether a system that ever uses the electric traction motor or the internal combustion engine at the same time never infringes. That is the understanding proposed by Defendants Honda, Kia, Nissan, Subaru and Mercedes.²²

With respect to term no. 25, several defendants propose inserting language about “the use of” and “in response to the claimed signal” into phrases already within term 23, and the same phrase in Claim 17. *Id.* at 158-59. Defendants argue that “the use of” should be added to convey that the claim encompasses activating one device while deactivating the other. *Id.* at 159. Plaintiff counters that this would exclude using both devices at once, which is done in a preferred embodiment of the invention when the ICE recharges the electric motor. *Id.* at 162.

Defendants also propose adding “in response to the claimed signal [generated by the actuator]” to indicate that the signal effects the change. *Id.* at 158, 160. Plaintiff responds that the signal does not necessarily activate or deactivate the ICE, but instead only needs to activate the electric traction motor. *Id.* at 163.

Although the language proposed for term no. 25 by Defendants Honda, Kia, Nissan, Subaru, and Mercedes is different from what they propose for term no. 23, it is confusing. But the substance of the argument is the same: (1) whether a vehicle that allows one propulsion method at a time to power a vehicle, but also allows different variations on propulsion method switching, could ever infringe; or, (2) whether, as those Defendants argue, such a vehicle would be categorically noninfringing, even if it at times it carries out the steps literally called for by the claims. For these reasons, in interpreting term nos. 23 and 25, they are considered together.

a. *The Language of the Claims*

Claim 8 is to a “control system for controlling propulsion equipment in a hybrid vehicle including a traction motor and an internal combustion engine, the control system comprising,” among other things:

- (i) “during conditions when the signal indicative of vehicle torque demand is within the threshold torque range, an actuator configured to generate a signal configured to activate the electric traction motor to drivingly propel the vehicle while de-engaging the internal combustion engine from propelling the vehicle;” and
- (ii) “during conditions when the signal indicative of vehicle torque demand is outside the threshold torque range, the actuator configured to generate a signal configured to deactivate the electric traction motor from drivingly propelling the vehicle while re-engaging the internal

²² These Defendants also propose several minor changes without explanation. These include changing “the actuator” to “an actuator” in claim 8, changing “from drivingly propelling” to “to drivingly propel” in claim 8, and deleting “while re-engaging the propulsion unit to propel the vehicle” from claim 15. Jt. Br., Dkt. 53 at 139-141. Plaintiff argues this is improper because the changes are “arbitrary and unwarranted.” *Id.* at 141.

UNITED STATES DISTRICT COURT
CENTRAL DISTRICT OF CALIFORNIA

CIVIL MINUTES – GENERAL

Case No. LA CV14-02454 JAK (JEMx) -- AND RELATED CASES

Date April 17, 2015

Title Signal IP v. American Honda Motor Co., Inc. -- AND RELATED CASES

combustion engine to propel the vehicle.”

’601 Patent at 8:48-50, 8:60-9:4.

The “threshold torque range” is “indicative of conditions of relatively low vehicle torque demand.” *Id.* at 8:54-55.

Claim 15 is to a “method for controlling a propulsion system in a hybrid vehicle including a traction motor and a propulsion unit, the method comprising,” among other things:

- (i) “during conditions when the sensed signal indicates a region of low-efficiency for the propulsion unit, generating a signal configured to activate the electric traction motor to drivingly propel the vehicle while de-engaging the propulsion unit from propelling the vehicle; and”
- (ii) “during conditions when the sensed signal indicates a region of high-efficiency for the propulsion unit, generating a signal configured to deactivate the electric traction motor from drivingly propelling the vehicle while re-engaging the propulsion unit to propel the vehicle.”

Id. at 9:30-32, 9:37-10:10.

Claim 17 is to a “computer-readable medium including computer-readable code for causing a computer to control a propulsion system in a hybrid vehicle including a traction motor and a propulsion unit, the computer-readable medium comprising,” among other things:

- (i) “during conditions when the sensed signal indicates a region of low-efficiency for the propulsion unit, segment code for generating a signal configured to activate the electric traction motor to drivingly propel the vehicle while de-engaging the propulsion unit from propelling the vehicle; and”
- (ii) “during conditions when the sensed signal indicates a region of high-efficiency for the propulsion unit, segment code for generating a signal configured to deactivate the electric traction motor from drivingly propelling the vehicle while re-engaging the propulsion unit to propel the vehicle.”

Id. at 10:15-18, 25-36.

Defendants argue that the claims support the need for a binary system, i.e., where the car is powered either by the electric motor or the propulsion unit. Under this approach, both activation and deactivation will always occur together if the car is operating. *Jt. Br.*, Dkt. 53 at 159. Plaintiff argues that the claim language does not preclude other possibilities including “using the electric motor to ‘augment the power capabilities of the vehicle.’” *Id.* at 162-63. The claims use the open language “comprising,” indicating that other possibilities are not foreclosed. Further, the claims recite that the power sources are activated or deactivated “from propelling the vehicle,” not from all uses. Thus, the language of the claims does not support Defendants’ proposed insertion of the words “always” or “use of.”

UNITED STATES DISTRICT COURT
CENTRAL DISTRICT OF CALIFORNIA

CIVIL MINUTES – GENERAL

Case No. LA CV14-02454 JAK (JEMx) -- AND RELATED CASES

Date April 17, 2015

Title Signal IP v. American Honda Motor Co., Inc. -- AND RELATED CASES

As to Defendants' proposal to specify that the engagement/disengagement is "in response to the claimed signal," this is unnecessary. The claims already state expressly that the propulsion units are activated or deactivated when "the sensed signal indicates a region of [low-efficiency / high-efficiency] for the propulsion unit." See '601 Patent at 8:60-61, 66-67, 9:37-38, 10:5-6, 25-26, 31-32. Because the claims already explain that a signal is necessary to initiate the process, Defendants' proposed language about the need for a signal is redundant.²³

b. The Specification

The specification teaches that in prior art propulsion systems, it was common to use both an internal combustion engine ("ICE") and an electric motor simultaneously, either to boost a low-power ICE or augment a high-power ICE. '601 Patent at 1:11-30. The present invention describes a more efficient system that switches back and forth between power sources. *Id.* at 1:30-34, 1:50-2:3. Thus, "it would be advantageous to use the electric motor not just to augment the power capabilities of the vehicle, but to use the electric motor during states or modes of vehicle operation that otherwise would have been commonly propelled by the ICE, regardless of whether the ICE would not have been operating very efficiently." *Id.* at 3:37-43.

Plaintiff argues that this "not just to augment" language shows that the "invention clearly does not preclude the electric motor from being used to augment the power as well." Jt. Br., Dkt. 53 at 142. Defendants disagree and contend that this passage shows that using one propulsion method and not the other is "the alleged point of novelty of the invention." *Id.* at 140.

Although the discussion of the prior art highlights advantages of using one propulsion method at a time, it also discusses using the electric motor "not just" to augment the ICE. See '601 Patent at 3:38-39. This suggests that the '601 Patent contemplates a system using both propulsion methods at certain times, and one or the other at different ones.

²³ Plaintiff also argues that the omission of the "signal" language is warranted because "the claims only require that the signal (or actuator) activate or deactivate the electric traction motor, not the ICE." Jt. Br., Dkt. 53 at 163. This argument is not convincing. The claims state that the signal is "configured to [activate / deactivate] the electric traction motor [to drivingly propel / from drivingly propelling] the vehicle while [de-engaging / re-engaging] the propulsion unit to propel the vehicle." From the language of the claims, it appears that the signal results in a change to both the electric traction motor and the propulsion unit, not the electric motor alone.

Furthermore, the specification teaches that the signal is "indicative of vehicle torque demand is processed to determine whether the vehicle torque demand is within the threshold torque range," '601 Patent at 1:58-60, and "[d]uring conditions when the sensed signal indicates a region of low-efficiency for the propulsion unit," the signal transmits information about whether the vehicle torque demand is in the low-efficiency threshold." *Id.* at 2:34-36. Figure 2 of the '601 Patent shows "a block diagram representation of an exemplary embodiment for the controller of FIG 1." *Id.* at 2:58-59. The figure shows the sensor sending a signal to the processor, which then sends a signal to the traction motor. Plaintiff argues that because the figure shows no connection to the ICE, the signal must not control the ICE. Jt. Br., Dkt. 53 at 163. However, this figure is only an example, and if the signal does not trigger the ICE to engage or disengage the ICE, it is not clear what does.

UNITED STATES DISTRICT COURT
CENTRAL DISTRICT OF CALIFORNIA

CIVIL MINUTES – GENERAL

Case No. LA CV14-02454 JAK (JEMx) -- AND RELATED CASES

Date April 17, 2015

Title Signal IP v. American Honda Motor Co., Inc. -- AND RELATED CASES

To be sure, all of the examples in the specification describe “activating” one propulsion method “to drivingly propel the vehicle” while “de-engaging” the other propulsion method “from propelling the vehicle.” *Id.* at Abstract, 2:12-26, 5:5-11. However, the Federal Circuit “has expressly rejected the view that if a patent describes only a single embodiment, the claims of the patent must be construed as being limited to that embodiment.” *Liebel-Flarsheim Co. v. Medrad, Inc.*, 358 F.3d 898, 906 (Fed. Cir. 2004) (collecting cases). Thus, the specification does not support requiring that it is “always” the case that only one propulsion method or the other is selected. Of course, dual-propulsion operation does not itself infringe. But Defendants propose a much more restrictive construction, one that states that single-propulsion does not infringe, if at other times there is dual propulsion. The specification does not warrant this restrictive interpretation.

Plaintiff cautions that Defendants’ inclusion of the word “use” in their construction would likely exclude the embodiment disclosed in the specification wherein “the ICE may be used to mechanically drive the electric machine as an alternator to recharge the power sources of the vehicle.” Jt. Br., Dkt. 53 at 162; ‘601 Patent at 5:8-11. Thus, the ICE can be used both “drivingly” to propel the vehicle and to recharge the battery. For this reason, Defendants’ construction is improper, because it is one that would exclude a preferred embodiment disclosed in the specification; this is something that is “rarely, if ever, correct.” *SanDisk Corp. v. Memorex Prods., Inc.*, 415 F.3d 1278, 1285 (Fed. Cir. 2005). However, Defendants respond that the word “use” is always tied to propulsion in their constructions, such that the recharging scenario is not excluded. Jt. Br., Dkt. 53 at 159.

c. The Prosecution History and the Extrinsic Evidence

The prosecution history and the extrinsic evidence do not bear on this question.

d. Conclusion

There is no support in the ‘601 Patent for imposing the limitation of “always” or “use of.” The insertion of the phrase “in response to the signal” would be redundant. No alternative constructions have been proposed. Thus, no construction of term nos. 23 and 25 is necessary.

Term No. 24: “Threshold Torque Range Indicative of Conditions of Relatively Low Vehicle Torque Demand” (Claim 8)

Plaintiff’s Proposal	Defendant’s Proposal	Court’s Construction
Plain and ordinary meaning. To the extent a construction is necessary, Plaintiff proposes: “Threshold torque range indicative of conditions of relatively low vehicle torque demand for the vehicle’s engine.”	<u>Honda, Kia, Nissan, Subaru, Mercedes, Porsche, VW/Bentley:</u> Indefinite <u>Honda</u> (Alternatively): “torque range where vehicle can be driven efficiently with just the electric motor”	Indefinite

UNITED STATES DISTRICT COURT
CENTRAL DISTRICT OF CALIFORNIA

CIVIL MINUTES – GENERAL

Case No. LA CV14-02454 JAK (JEMx) -- AND RELATED CASES

Date April 17, 2015

Title Signal IP v. American Honda Motor Co., Inc. -- AND RELATED CASES

Defendants argue that the scope of the term cannot be determined. *Jt. Br.*, Dkt. 53 at 146. Plaintiff responds by arguing that “a POSA can readily determine the specific threshold torque range indicative of conditions of relatively low vehicle torque demand for the vehicle’s engine.” Plaintiff adds that the present case is distinguishable from those cited by Defendants, in which a disputed term was plainly subjective, because “torque demand” is an objective concept. *Id.* at 152. In the alternative, Plaintiff and Honda propose constructions.

Plaintiff frames the dispute as whether a term that is intentionally open-ended to allow adaptation to different products is indefinite, and argues that such terms are acceptable, citing *Orthokinetics, Inc. v. Safety Travel Chairs, Inc.*, 806 F.2d 1565, 1576 (Fed. Cir. 1986). In *Orthokinetics*, the Federal Circuit reversed a district court’s finding that “so dimensioned as to be insertable through the space between the doorframe of an automobile and one of the seats thereof” is indefinite, reasoning that “one of ordinary skill in the art would easily have been able to determine the appropriate dimensions.” *Id.* The court held that “[a]s long as those of ordinary skill in the art realized that the dimensions could be easily obtained, § 112, 2d ¶ requires nothing more. The patent law does not require that all possible lengths corresponding to the spaces in hundreds of different automobiles be listed in the patent, let alone that they be listed in the claims.” *Id.*²⁴

The absence of a fixed meaning can render claims indefinite. *Aquatic AV, Inc. v. Magnadyne Corp.*, No. C 14-01931 WHA, 2015 WL 926425, at *3 (N.D. Cal. Feb. 25, 2015) (applying *Nautilus*, holding “hermetically sealed” indefinite where patentee proposed at various times that it had definitions including the terms “water resistant,” “watertight,” “IPX,” “IP Code,” “110.15–1,” and “Coast Guard”). “Absent a meaningful ‘definiteness’ check, applicants face powerful incentives to inject ambiguity into their claims.” *Id.*

a. *The Language of the Claim*

Claim 8 describes “a threshold torque range indicative of conditions of relatively low vehicle torque demand.” ‘601 Patent at 8:54-55. The system uses a “signal indicative of vehicle torque demand to determine whether the vehicle torque demand is within the threshold torque range.” *Id.* at 8:56-59. If the signal indicates that torque demand is within the threshold torque range, the electric traction motor is activated, and if it is outside the threshold torque range, the internal combustion engine is activated. *Id.* at 8:60-9:4. Thus, the claim presents circular language in which the threshold torque range is the range within which use of the electric motor of a hybrid vehicle is appropriate.

b. *The Specification*

The specification provides an example in which a sensor is “coupled to the accelerator pedal to detect

²⁴ *Orthokinetics* predates the decision by the Supreme Court to abrogate the Federal Circuit’s “insolubly ambiguous” standard for indefiniteness in favor of the “reasonably certainty” standard in *Nautilus*, 134 S.Ct. at 2124. However, *Orthokinetics* (1) does not apply the “insolubly ambiguous” standard; (2) predates by more than 15 years the Federal Circuit’s “insolubly ambiguous” cases; and (3) uses reasoning that is consistent with *Nautilus*.

UNITED STATES DISTRICT COURT
CENTRAL DISTRICT OF CALIFORNIA

CIVIL MINUTES – GENERAL

Case No. LA CV14-02454 JAK (JEMx) -- AND RELATED CASES

Date April 17, 2015

Title Signal IP v. American Honda Motor Co., Inc. -- AND RELATED CASES

whether the accelerator pedal is fully depressed. In this situation, one would not want to be in an electric traction mode.” *Id.* at 4:49-52. On the other hand, “if the accelerator is just partially depressed that would indicate a mode of small torque demand and one would want to switch over to the electric traction mode.” *Id.* at 4:52-55. These examples describe positions at the extremely high and extremely low ends of the spectrum, but do not help define the boundaries of “relatively high” and “relatively low.”

In the specification, an exemplary threshold (“relatively low”) torque range runs “from a lower limit indicative of any non-negative torque demand to an upper limit of about 50 Nm.” *Id.* at 4:57-61. When the vehicle torque demand signal “is either negative or greater than 50 Nm, then the electric machine would be commanded to a generating state.” *Id.* at 5:55-58. Certainly, such a fixed range would be definite. But Plaintiff does not contend that a fixed range applies, and for the reasons discussed below in connection with the extrinsic evidence, such a claim would not make sense.

The specification also explains that “the threshold torque range could have different values depending on the specific propulsion equipment being utilized or depending on vehicle use location or both.” *Id.* at 6:2-5. For example, a high-altitude, hilly location could create different torque requirements than a low-altitude, flat location. *Id.* at 6:1-9. “[A]lthough the threshold torque range may be selected to have a constant value, it will be appreciated that many learning techniques may be used for selecting an optimal value for the threshold torque range based on historical vehicle performance.” *Id.* at 6:15-19.

c. The Prosecution History

The prosecution history does not bear on this question.

d. The Extrinsic Evidence

The competing experts agree that the threshold torque range varies greatly among vehicles.²⁵ Bower Decl. at ¶ 37, JA-0542; Ronney Decl. at ¶ 21, JA-0433. (“I agree with Mr. Bower that in absolute terms, a high torque demand for an economy car might be a low torque demand for a sports car or light truck.”).

According to Ronney, who is Plaintiff’s expert, a person of skill in the art (“POSA”) would understand that “the threshold torque range indicative of conditions of relatively low vehicle torque demand is determined by the context,” Ronney Decl. at ¶ 21, JA-0433, and a “POSA can use his/her judgment to apply the range for the vehicle and the operating condition. The patent cannot include every vehicle and every operating condition, but a POSA can apply the range for the vehicle and operating condition.” *Id.* at ¶ 23, JA-0434.

Bower, who is Defendants’ expert, contends that “relatively low vehicle torque demand” is subjective

²⁵ VW/Bentley argue that the extrinsic evidence need not be considered, and this issue should be decided on the intrinsic evidence alone. Given that the relevant standard is whether the “claims, read in light of the specification delineating the patent, and the prosecution history, fail to inform, with reasonable certainty, those skilled in the art about the scope of the invention,” *Nautilus*, 134 S. Ct. at 2124, it is appropriate to consider the evidence presented here by skilled artisans.

UNITED STATES DISTRICT COURT
CENTRAL DISTRICT OF CALIFORNIA

CIVIL MINUTES – GENERAL

Case No. LA CV14-02454 JAK (JEMx) -- AND RELATED CASES

Date April 17, 2015

Title Signal IP v. American Honda Motor Co., Inc. -- AND RELATED CASES

and not explained in the patent. Bower Decl. at ¶¶ 34-40, JA-0451-53. Considering the figure from the incorporated-by-reference Chan article, which is reproduced below, Bower argues that the peak torque is around 62 Nm, which means that the patent's exemplary 0-50 Nm torque range could not be a "relatively low torque demand" for a typical vehicle. *Id.* at ¶ 40, JA-0543. Bower opines that "it is impossible for a POSA to specify a 'relatively low' threshold torque range for the vehicle depicted [in Chan] with reasonable certainty." *Id.*

Plaintiff responds that Bower should not have attempted to apply the 50 Nm example to Chan, "which describes a weaker engine having a maximum torque of only 62 Nm." *Jt. Br.*, Dkt. 53 at 155. According to Ronney, the vehicle depicted in Chan is not representative of a typical one. Ronney Decl. ¶ 24, JA-0435. Indeed, it would not make sense to apply the 0-50 Nm range to the Chan figure because 50 Nm is not a low torque for that vehicle. Ronney explains that the popular Toyota Prius Hybrid has a maximum torque of 111 NM. He adds that 50 Nm is 45% of that amount and is reasonably considered "relatively low." *Id.* Ronney address neither what percentage of torque 50 Nm represents for other hybrid vehicles, nor how much more than 45% would still be "relatively low."

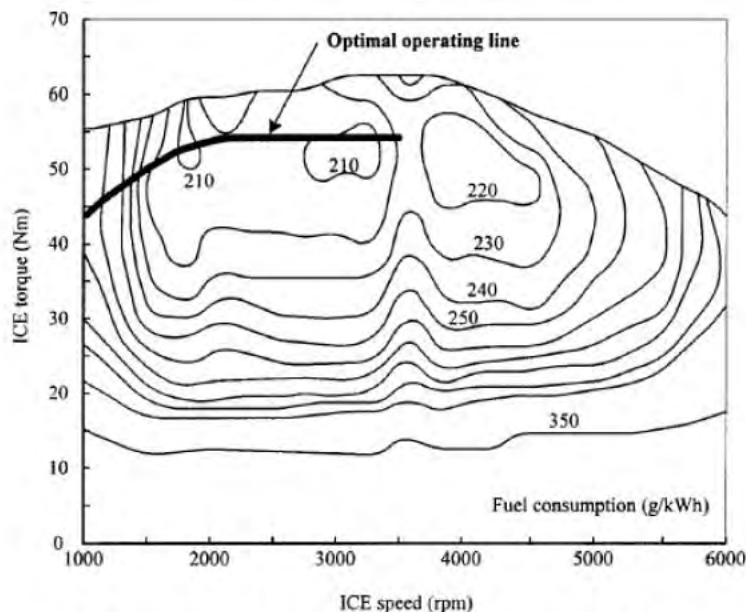

If the claim were interpreted to incorporate the fixed 0-50 Nm range, this definiteness problem would not be presented. However, neither party argues the torque should be fixed in this range. Indeed, that this range is not relatively low in the vehicle depicted in Chan shows that the specification, which incorporates Chan by reference, does not support limiting the relatively low torque to this exemplary range for all vehicles.

In his deposition, Ronney testified that many factors are at play in determining whether a vehicle is operating at a "relatively low" torque threshold: "the maximum torque that the vehicle can produce at that time . . . or some estimate of that," "some indication as to the vehicle torque demand at that time," and "the operating conditions." Ronney Dep. at 65:13-66:16, JA-0475-76. When asked whether 60

UNITED STATES DISTRICT COURT
CENTRAL DISTRICT OF CALIFORNIA

CIVIL MINUTES – GENERAL

Case No. LA CV14-02454 JAK (JEMx) -- AND RELATED CASES

Date April 17, 2015

Title Signal IP v. American Honda Motor Co., Inc. -- AND RELATED CASES

percent was relatively low, Ronney answered that it is probably on the high side, but he would “certainly want more information to make a better determination,” and “that can change a lot.” *Id.* at 68:19-69-13, JA-0476. Ronney also indicated that “a person of ordinary skill can use his or her judgment to apply the range for the vehicle and the operating condition,” potentially arriving at different results. *Id.* at 153:17-154:8, JA-0497-98.

This evidence shows that the claims do not define the scope of the invention with “reasonable certainty.” The opinions of the competing experts confirm one point: It would be difficult for an expert to pinpoint a torque range indicative of “relatively low” torque demand. Unlike in *Orthokinetics*, a skilled artisan could not simply perform a simple measurement on a given car to calculate the appropriate numbers. Nor is there a fixed percentage of the total torque for a given vehicle that defines a “relatively low” torque demand. Indeed, it remains entirely unclear how an expert could consistently discriminate between relatively high and low torque demands even for a single car.

e. Conclusion

For the foregoing reasons, claim 8 is indefinite.

Term No. 25: [See Term No. 23 (above)]

Term No. 26: “Regions of Relatively High and Low Efficiency” / “Region of -Efficiency” / “Region of High Efficiency” / “Relatively High and Relatively Low Efficiency (Claims 15, 17)”

Plaintiff’s Proposal	Defendant’s Proposal	Court’s Construction
<p>Not Indefinite</p> <p>Plain and ordinary meaning.</p> <p>To the extent a construction is necessary, Plaintiff proposes “Region of relatively high and low efficiency” / “region of high efficiency” / “regions of low efficiency” / “relatively high and relatively low efficiency” / “high efficiency / low efficiency” for the vehicle’s engine.</p>	<p><u>Honda, Kia, Nissan, Subaru, Mercedes, Porsche, VW / Bentley:</u></p> <p>Indefinite</p> <p><u>Nissan, Honda:</u> Alternatively (for “region of high-efficiency”), “region of high efficiency, mutually exclusive and collectively exhaustive of regions of low efficiency”</p> <p>Alternatively (for “region of low-efficiency”), “region of low efficiency, mutually exclusive and collectively exhaustive regions of low efficiency”</p>	<p>Indefinite</p>

UNITED STATES DISTRICT COURT
CENTRAL DISTRICT OF CALIFORNIA

CIVIL MINUTES – GENERAL

Case No. LA CV14-02454 JAK (JEMx) -- AND RELATED CASES

Date April 17, 2015

Title Signal IP v. American Honda Motor Co., Inc. -- AND RELATED CASES

Several defendants contend that the terms are indefinite because “a person of ordinary skill would not know with reasonable certainty whether their judgment of relatively high and low efficiency infringes claims 15 or 17.” Jt. Br., Dkt. 53 at 166. Plaintiff argues that energy efficiency differs based on the type of engine and operating conditions, and a skilled artisan could easily apply the term to a given vehicle at a given time. *Id.* at 172. Plaintiff incorporates the arguments it made for term no. 24, which deals with a similar issue. *Id.* In particular, Plaintiff contends that the efficiency of a vehicle is not a subjective concept.

a. The Language of the Claims

Both claims 15 and 17 of the ‘601 patent describe “mapping respective regions of relatively high and low efficiency in an efficiency map for the propulsion unit.” ‘601 Patent at 9:33-34, 10:20-22. Then, a signal is sensed “indicative of said regions of relatively high and low efficiency.” *Id.* at 9:35-36, 10:23-24. If the signal indicates a “region of low-efficiency for the propulsion unit,” a signal triggers the electric traction motor. *Id.* at 9:37-10:4, 10:25-30. If the signal indicates a “region of high-efficiency for the propulsion unit,” a signal triggers the propulsion unit and deactivates the electric traction motor. *Id.* at 10:5-11, 32-36. Thus, the regions of relatively high and low efficiency determine whether to activate or deactivate the electric traction motor or the propulsion unit. The claims do not explain what constitutes “relatively high” or “relatively low” efficiency.

b. The Specification

The specification explains that, in an engine efficiency map, there are “distinct regions of engine efficiency during operation of an internal combustion engine,” fuel cell engine, or “other type of non-electrically powered engine.” *Id.* at 1:4-11. “[T]he efficiency map for an engine may be dependent on altitude and/or temperature because air density varies, and oxygen content in the air that fills the cylinder may also vary. Thus, it is contemplated that one could adjust the engine efficiency map as a function of such operational parameters.” *Id.* at 6:49-54. Further, “the energy efficiency may differ based on the type of engine and engine speed.” *Id.* at 6:58-61.

Defendants correctly point out that “the specification does not disclose even a single example of high or low efficiency levels.” Jt. Br., Dkt. 53 at 165. The only indication of high or low efficiency levels comes from the Chan paper, which the specification incorporates by reference. Chan obliquely shows high efficiency with the “optimal operating line,” but does not speak specifically to the dividing line between high and low efficiency:

UNITED STATES DISTRICT COURT
CENTRAL DISTRICT OF CALIFORNIA

CIVIL MINUTES – GENERAL

Case No. LA CV14-02454 JAK (JEMx) -- AND RELATED CASES

Date April 17, 2015

Title Signal IP v. American Honda Motor Co., Inc. -- AND RELATED CASES

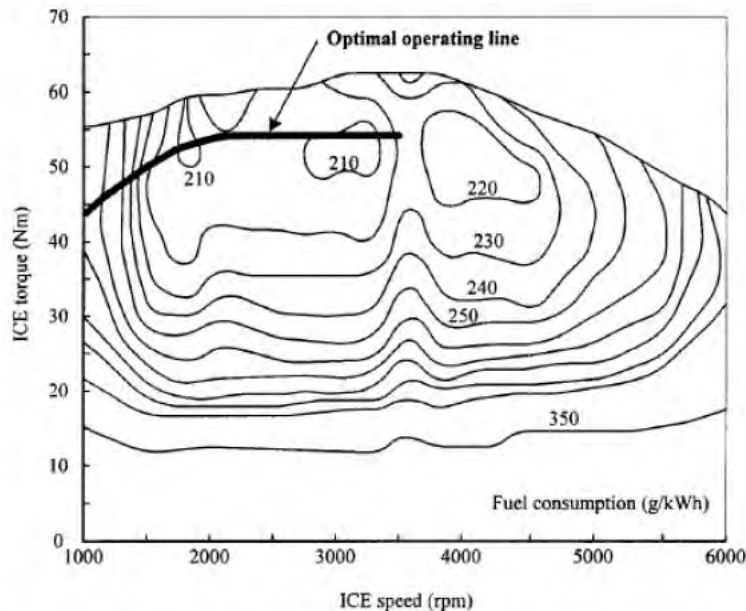

Plaintiff, conceding specific examples are not provided in the specification, argues that they are not necessary in the specification because a skilled artisan could easily ascertain what region is of high or low efficiency for a given vehicle. That is not apparent from the specification.

c. The Prosecution History

The prosecution history does not bear on this question.

d. The Extrinsic Evidence²⁶

In his declaration, Ronney, opined that “a POSA would know how to determine regions of relatively high and low efficiency from the map for a particular engine,” and “would understand conditions corresponding to ‘relatively high fuel efficiency’ to depend on the engine.” Ronney Decl. at ¶ 29, JA-0437.

Considering the aforementioned figure from Chan, Ronney explains that the numbers “represent conditions having similar fuel consumption per unit of shaft work produced. The numbers . . . associated with each ring represent the fuel consumption measured in grams of fuel consumed per kilowatt-hour of shaft work produced (g/kWhr).” Ronney opined that such maps were well-known to skilled artisans in 2002. *Id.* at ¶ 26, JA-0436. The plateau at 210 shows maximum fuel efficiency. *Id.* at

²⁶ VW/Bentley argue that the extrinsic evidence need not be considered, and this issue should be decided on the intrinsic evidence alone. Given that the relevant standard is whether the “claims, read in light of the specification delineating the patent, and the prosecution history, fail to inform, with reasonable certainty, those skilled in the art about the scope of the invention,” *Nautilus*, 134 S. Ct. at 2124, it is appropriate to consider the evidence presented about the understandings of skilled artisans.

UNITED STATES DISTRICT COURT
CENTRAL DISTRICT OF CALIFORNIA

CIVIL MINUTES – GENERAL

Case No. LA CV14-02454 JAK (JEMx) -- AND RELATED CASES

Date April 17, 2015

Title Signal IP v. American Honda Motor Co., Inc. -- AND RELATED CASES

¶ 29, JA-0437. Further, a “POSA would understand that a fuel consumption map or a fuel efficiency map is specific to a particular engine.” *Id.*

In response, Bower opined that “the phrases ‘regions of relatively high and low efficiency,’ [etc.] include terms of degree, upon which reasonable people could differ greatly.” Bower Decl. at ¶ 53, JA-0549. With respect to the figure from Chan, Bower agrees with Ronney that the numbers represent the amount of fuel consumed per unit energy, that this figure represents minimum fuel consumption and maximum fuel economy, and that such a map “is like a fingerprint for a person and is specific to each engine design.” *Id.* at ¶ 47, JA-0546. However, Bower opines that the “applicant should have delineated the regions that he would characterize as relatively high and relatively low efficiency, but chose not to do so. . . . unfortunately, there is absolutely nothing in the specification to teach a POSA how to determine what fuel efficiencies are ‘relatively high’ or ‘relatively low.’” *Id.* at ¶ 49, JA-0547.

In his deposition, Ronney testified that there could be substantial variation in levels of high and low efficiency. Thus, it “would just depend on the particular mode of operation.” Ronney Depo. at 115:14-117:8, JA-0488. When asked about the potential bounds, Ronney testified that “if you are anything below the highest efficiency, you might want to say I only want to operate at the highest efficiency on the gasoline engine and at other times on the electric drive.” When asked if that would practice this claim element, Ronney said that it would “[b]ecause it just says relatively high and low. I mean you could say that 220 is relatively low relative to 210,” and “the claim just says regions of relatively high and low efficiency.” *Id.* at 118:1-18, JA-0489.

The expert testimony shows that a skilled artisan would have difficulty determining regions of relatively high or low efficiency, much as described above regarding term no. 24. Indeed, Ronney’s testimony indicates that this term is almost entirely subjectively determined. This does not define the scope of the invention with “reasonable certainty.”

e. Conclusion

For the foregoing reasons, claims 15 and 17 are indefinite.

Term No. 27: “Mapping” / “Mapping the Respective Regions of Relatively High and Low Efficiency in an Efficiency Map for the Propulsion Unit” (Claims 15 & 17)

Plaintiff’s Proposal	Defendant’s Proposal	Court’s Construction
Plain and ordinary meaning.	<u>Honda, Nissan, Subaru, Mercedes, Porsche</u> (for “mapping”): “creating a representation of” <u>BMW</u> (for overall phrase): “plotting regions of relatively high and low efficiency in an efficiency map for the propulsion unit”	The Court construes these terms only insofar as noting that machine readable data can, for the purposes of the claim, constitute a “map.”

UNITED STATES DISTRICT COURT
CENTRAL DISTRICT OF CALIFORNIA

CIVIL MINUTES – GENERAL

Case No. LA CV14-02454 JAK (JEMx) -- AND RELATED CASES

Date April 17, 2015

Title Signal IP v. American Honda Motor Co., Inc. -- AND RELATED CASES

This term will be analyzed together with Term No. 28, immediately following.

Term No. 28: "Efficiency Map" (Claims 15 & 17)

Plaintiff's Proposal	Defendant's Proposal	Court's Construction
<p>Plain and ordinary meaning.</p> <p>To the extent a construction is necessary, Plaintiff proposes: "A machine-readable representation of efficiency"</p>	<p><u>Honda, Nissan, Subaru, Mercedes, Porsche:</u></p> <p>"a graphical representation of the relationship between engine torque, engine speed (rpm), and efficiency"</p>	<p>"a machine-readable representation of efficiency"</p>

Because term nos. 27 and 28 raise the same issues, they are construed together. The parties agree that "an 'efficiency map' is a representation of some kind." Jt. Br., Dkt. 53 at 179. Several defendants propose that "mapping" means "creating a representation of." *Id.* at 176. However, although the constructions of Defendants imply that the representation is graphical, Plaintiff's understanding encompasses machine-readable data. Plaintiff argues that "creating a representation" connotes, improperly, that the efficiency data needs to be "created" during the mapping step, rather than loaded from memory. *Id.* at 179-80. This language does not necessarily preclude using pre-loaded data.

a. The Language of the Claims

Both claims 15 and 17 of the '601 patent describe "mapping respective regions of relatively high and low efficiency for the propulsion unit." '601 Patent at 9:33-34, 10:20-21. This is done "in an efficiency map." Claim 15 covers a "method for controlling a propulsion system in a hybrid vehicle," and claim 17 covers "a computer-readable medium . . . for causing a computer to control a propulsion system in a hybrid vehicle." *Id.* at 9:30-31, 10:15-17. In light of the claims, "mapping" is some method of specifying regions of high and low efficiency in a propulsion unit that can be performed on a computer-readable medium.

The claims do not otherwise define or restrict the meaning of "mapping." They do show that mapping is performed for the purposes of the system to control the switching of propulsion units. There is no evidence that it is done for the benefit of the driver. For these reasons, the language of the claims does not support the contention that the map should be a pictorial representation.

b. The Specification

The method of the invention "allows mapping respective regions of relatively high and low efficiency in an efficiency map for the propulsion unit." *Id.* at 2:30-33. "If one had available an engine efficiency map, one would be able to observe distinct regions of engine efficiency during operation of an internal combustion engine." *Id.* at 3:4-6. In an exemplary embodiment, "block 52 [in figure 4, reproduced below] allows mapping respective regions of relatively high and low efficiency in an efficiency map for the propulsion unit." *Id.* at 7:8-10. These are the only references to "mapping" in the specification.

UNITED STATES DISTRICT COURT
CENTRAL DISTRICT OF CALIFORNIA

CIVIL MINUTES – GENERAL

Case No. LA CV14-02454 JAK (JEMx) -- AND RELATED CASES

Date April 17, 2015

Title Signal IP v. American Honda Motor Co., Inc. -- AND RELATED CASES

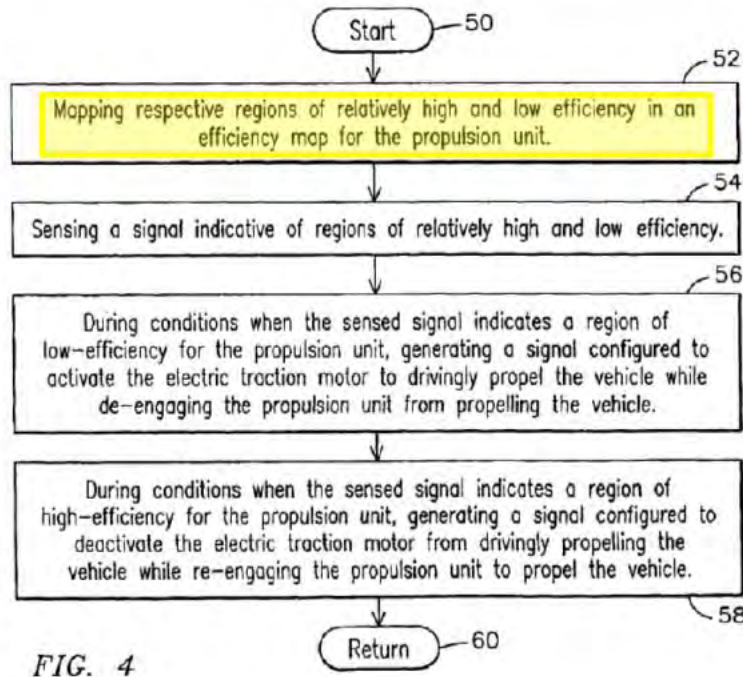

Plaintiff argues that “the efficiency data can be implemented as logic as well” because the specification “teaches that the threshold range can have a ‘factory-loaded’ or ‘constant’ value,” citing the specification at 6:9-19. *Jt. Br.*, Dkt. 53 at 180. This portion describes using “a factory-loaded value for the upper limit of the threshold torque range,” and does not speak to the mapping process itself. *Id.*

When examined as a whole, the specification reinforces the language of the claims in that any “mapping” done is for the benefit of a computer to control the propulsion sources. That “[i]f one had available an engine efficiency map, one would be able to observe distinct regions of engine efficiency during operation of an internal combustion engine” is true, but does not suggest that as used in the claim, “mapping” is to produce a picture for a person, rather than actionable data for a computer. See ‘601 Patent at 3:4-8.

The method of the invention “allows mapping respective regions of relatively high and low efficiency in an efficiency map for the propulsion unit.” *Id.* at 2:30-33. “If one had available an engine efficiency map, one would be able to observe distinct regions of engine efficiency during operation of an internal combustion engine.” *Id.* at 3:4-6. In an exemplary embodiment, “block 52 [in figure 4, reproduced above] allows mapping respective regions of relatively high and low efficiency in an efficiency map for the propulsion unit.” *Id.* at 7:8-10.

The specification describes someone observing the efficiency map, which Defendants argue means it must be a graphical, not machine-readable, representation. On the other hand, creating a map for the driver to view would have little utility in a mechanism that switches propulsion units depending on fuel efficiency. The specification describes a “control algorithm” with the goal “to identify the regions of

UNITED STATES DISTRICT COURT
CENTRAL DISTRICT OF CALIFORNIA

CIVIL MINUTES – GENERAL

Case No. LA CV14-02454 JAK (JEMx) -- AND RELATED CASES

Date April 17, 2015

Title Signal IP v. American Honda Motor Co., Inc. -- AND RELATED CASES

operation of the ICE where the energy efficiency is particularly low,” indicating the map is used by the algorithm. *Id.* at 6:55-61.

The ‘601 Patent incorporates Chan by reference. Chan presents an exemplary map:

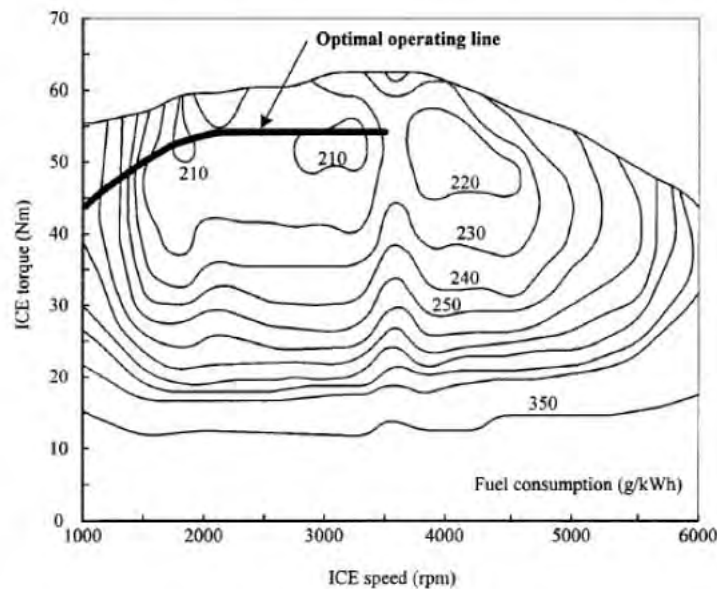

Defendants argue that Chan “explains that an efficiency map is a graphical representation of fuel consumption (i.e., efficiency) at different engine speeds and torque.” In Chan, this figure is described as the “[o]ptimal operating line on an ICE fuel consumption map.” Chan at 261, JA-0618. Chan indicates that a fuel consumption, i.e. efficiency, map can be graphically depicted, but it does not foreclose other representations.

c. The Prosecution History

The prosecution history does not bear on this question.

d. The Extrinsic Evidence

Bower describes a fuel consumption map in terms of a pictorial representation, but does not speak to the “mapping” process. Bower Decl. at ¶¶ 46-48, JA-0545-47. Defendants cite several efficiency maps from textbooks, which are reproduced below. Defendants argue this demonstrates that it is well understood that an efficiency map is known within the industry to be a graphical representation of the relationship between engine torque, engine speed, and efficiency.

UNITED STATES DISTRICT COURT
CENTRAL DISTRICT OF CALIFORNIA

CIVIL MINUTES – GENERAL

Case No. LA CV14-02454 JAK (JEMx) -- AND RELATED CASES

Date April 17, 2015

Title Signal IP v. American Honda Motor Co., Inc. -- AND RELATED CASES

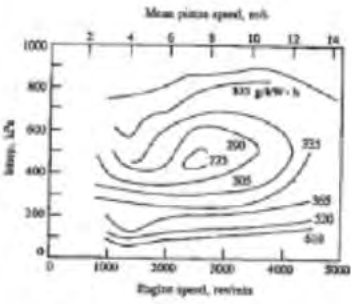
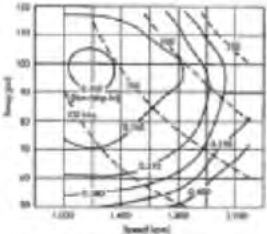
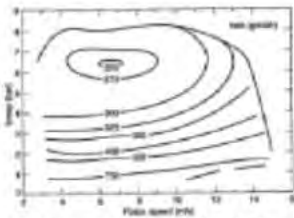
<p>John B. Heywood, <i>Internal Combustion Engine Fundamentals</i>, 839 (1st ed. 1988)</p>	<p>Edward F. Obert, <i>Internal Combustion Engines & Air Pollution</i>, 46-47, 55 (3rd ed. 1973)</p>	<p>Collin R. Ferguson, <i>Internal Combustion Engines Applied Thermosciences</i> (2nd ed. 2000)</p>
	 <p>FIG. 3-25. Performance map of a diesel engine. Model: 6M, 6-cyl., 5 x 5 1/2 in., 204 in.³, open chamber.</p>	 <p>Figure 3-24. Performance map of a spark-ignition engine. Model: 6M, 6-cyl., 5 x 5 1/2 in., 204 in.³, open chamber.</p>

Although the figure in Chan uses axes of speed and torque to represent efficiency, the other figures use units of speed and pressure to represent efficiency. Thus, it would be overly restrictive to require only “the relationship between engine torque, engine speed (rpm), and efficiency” to be depicted.

It is also significant that these maps are presented for the purpose of demonstrating these concepts to a person. In the context of the claims, the maps are used by the computer to shift between power sources. Thus, Plaintiff argues that this argument “conflates the graphical map intended for humans with the machine-readable map referenced in the claims.” *Jt. Br.*, Dkt. 53 at 184. According to Ronney, “an efficiency map can be represented in different forms, depending on the context, and who or what is processing the information.” *Ronney Decl.* at ¶ 27, JA-0436. Ronney opines that “a POSA would understand that the ‘efficiency map’ referenced in the claims . . . refers to information in machine readable form, which would typically be in the form of a database table, mathematical formula, or other data structure, not a graphical representation of data.” *Id.*

Overall, the extrinsic evidence suggests that the map need not be graphical or restricted to a function of torque.

e. Conclusion

The language of the patent does not support limiting “mapping” to creating a pictorial representation or plot. Therefore, term no. 27 is construed only to note that machine readable data can, for purposes of the claim, constitute a “map.”

The language of the patent does not support interpreting an “efficiency map” as a physical representation or plot. To the contrary, the map would only be useful within the claims if it were machine-readable. The extrinsic evidence indicates that the relationship need not be restricted to one

UNITED STATES DISTRICT COURT
CENTRAL DISTRICT OF CALIFORNIA

CIVIL MINUTES – GENERAL

Case No. LA CV14-02454 JAK (JEMx) -- AND RELATED CASES

Date April 17, 2015

Title Signal IP v. American Honda Motor Co., Inc. -- AND RELATED CASES

between engine torque, engine speed, and efficiency. Thus, the construction “a machine-readable representation of efficiency” is adopted for term no. 28.

F. The ‘374 Patent²⁷

The ‘374 Patent was issued on October 31, 1995 to assignee Delco. It discloses a method and apparatus for tire pressure monitoring and keyless entry control using common hardware. ‘374 Patent at 1:6-11. The ‘374 Patent has seven claims, three of which are asserted by Plaintiff. Joint Rep. at 4. The parties request construction of four terms in the ‘374 Patent.

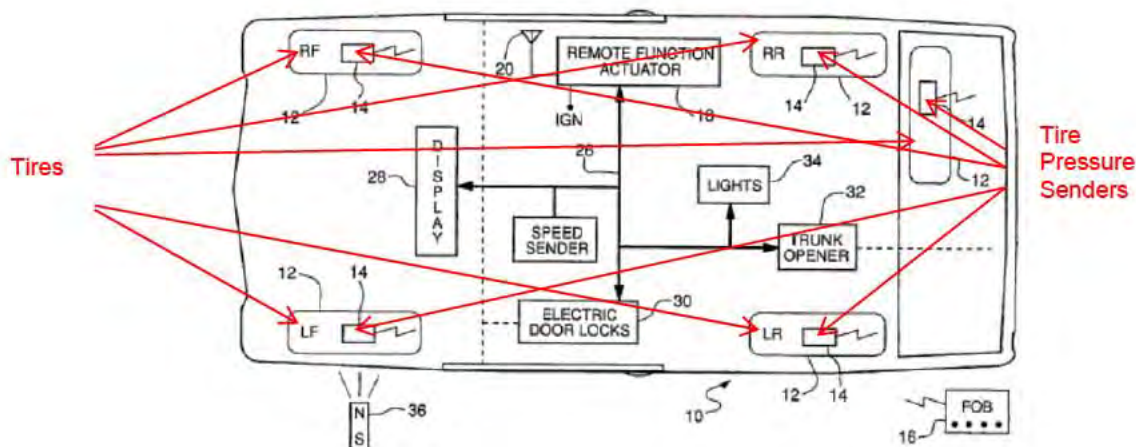

Figure 1 -- Schematic Diagram of System

The system combines tire pressure monitoring and keyless entry functions to save system resources. ‘374 Patent at 1:49-51.

Figure 1 of the ‘374 Patent, which is reproduced above, with annotations added, shows a schematic diagram of a keyless entry and tire pressure warning system. *Id.* at 1:1-2. Within each tire is an air pressure sender that transmits radio signals carrying pressure-related information. *Id.* at 3:30-33. Each air pressure sender has a unique identification code so that the location of the pressure information can be transmitted. *Id.* at 3:33-35. A fob transmits radio signals to unlock doors, open the trunk or turn on the lights. *Id.* at 3:35-39.

A remote function actuator in the vehicle receives signals from the tire pressure sender and fob. *Id.* at 3:39-42. The remote function actuator, which is shown below in Figure 2 of the ‘374 Patent, includes an antenna, RF receiver, and processor. *Id.* at 3:40-44.

²⁷ The ‘374 Patent is provided as Exhibit V, JA-0736-45.

UNITED STATES DISTRICT COURT
CENTRAL DISTRICT OF CALIFORNIA

CIVIL MINUTES – GENERAL

Case No.	LA CV14-02454 JAK (JEMx) -- AND RELATED CASES	Date	April 17, 2015
Title	Signal IP v. American Honda Motor Co., Inc. -- AND RELATED CASES		

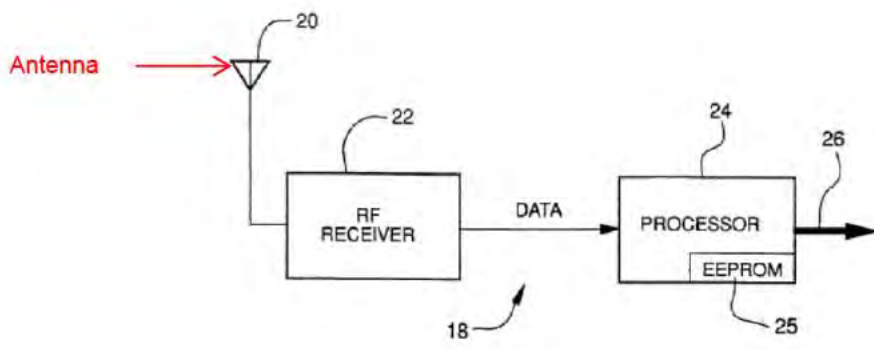

Figure 2-- Remote Function Actuator

Both the tire pressure sender and the fob use compatible pulse width modulated data formats. *Id.* at 4:48-51. Figure 4 of the '374 Patent, which is set forth below, shows the general format of the communications sent from the tire pressure sender or the fob, broken up into several different codes.²⁸ *Id.* at 4:52-53. The message formats comprise a preamble, a header which identifies the source as a tire sender or keyless entry fob, a unique transmitter identification code four bytes long, security or pressure data and a function code. *Id.* at 4:52-55.

PREAMBLE	HEADER	ID	SECURITY / PRESSURE DATA	FUNCTION CODE	CHECK SUM
----------	--------	----	--------------------------	---------------	-----------

Figure 4

The function and security / pressure data codes, which are shown above, use the same format for the tire pressure sender and the fob, but contain different content. *Id.* at 4:48-59. The function code for each is 1 byte long. For the tire pressure sender, the code denotes sign-up, state of health, pressure low, or pressure high. *Id.* at 4:59-62. For the fob, the code denotes sign-up, door lock, door unlock, trunk open, or light on commands. *Id.* at 4:62-64. Using the security/pressure data code, the tire pressure sender transmits tire pressure data, and the fob transmits security data identifying itself. *Id.* at 4:64-66.

The invention also has a system of magnetic switches for tracking the location of each tire. For example, it would be used if the tires had been rotated. In this way it can accurately send information about which tire has low air pressure. *Id.* at 2:46-61. The switches are activated through a "sign-up procedure," wherein a person moves a magnet to each tire in a specified order. *Id.* at 5:57-59. In response to the magnetic activation, the sender in each tire transmits a sign-up message with an identification code. *Id.* at 5:60-61. The processor stores the codes in the order received, and if all five tires are entered within an adequate timeframe, the tire positions are permanently stored into the memory. The process should be repeated whenever the tires are rotated. *Id.* at 5:57-6:19.

²⁸ As discussed below, the specification's internally conflicting terminology gives rise to the question whether Figure 4 illustrates a "data format," as that term is used in the claims, or a "message format."

UNITED STATES DISTRICT COURT
CENTRAL DISTRICT OF CALIFORNIA

CIVIL MINUTES – GENERAL

Case No. LA CV14-02454 JAK (JEMx) -- AND RELATED CASES

Date April 17, 2015

Title Signal IP v. American Honda Motor Co., Inc. -- AND RELATED CASES

The asserted '374 Patent claims are reproduced below, with the disputed terms in bold.

1. A vehicle remote function actuator system having a single on-board radio receiver, comprising
 - at least one remote tire transmitter for transmitting radio frequency tire condition data;
 - at least one remote vehicle function transmitter for transmitting radio frequency vehicle function data;
 - a radio receiver mounted on the vehicle for receiving data from said remote tire transmitter and said remote vehicle function transmitter;
 - a controller having a pressure detector for providing pressure condition data to said remote tire transmitter and causing said remote tire transmitter to transmit the pressure condition data to said receiver;
 - the remote transmitters **all having the same data format but distinctive codes for tire transmitters and vehicle function transmitters**;
 - a processor connected to the receiver and coupled to a display device and to a vehicle function device for responding to the transmitted data; and
 - the processor being programmed to effect display of pressure condition data on said display device when a transmitted data contains a distinctive code for tire transmitters, and to activate said vehicle function device when a transmitted data contains a distinctive code for the vehicle function transmitters.

3. A combined keyless entry and low tire pressure warning system for a vehicle having electric door locks and a warning display comprising:
 - a set of remote transmitters comprising radio frequency tire transmitters one mounted in **each tire** for transmitting data messages including modulated data and an identification code;
 - a radio frequency keyless entry transmitter for transmitting lock operation commands;
 - a radio receiver mounted on the vehicle for receiving data messages from the tire transmitters and lock operation commands from the keyless entry transmitter;
 - a processor coupled with the receiver, the electric door locks and the warning display for controlling the locks and the display according to transmitted commands and messages;
 - a controller coupled with **each tire** transmitter having a pressure detector for providing pressure data to the tire transmitter, an identification code for transmission with the pressure data, and a **switch activated by a vehicle user** for transmitting a **sign-up message** including the identification code for that tire location, the receiver unit including means for storing identification codes from the transmitted **sign-up messages** for comparison with subsequently transmitted data messages to differentiate data transmitted from various tire locations.

UNITED STATES DISTRICT COURT
CENTRAL DISTRICT OF CALIFORNIA

CIVIL MINUTES – GENERAL

Case No. LA CV14-02454 JAK (JEMx) -- AND RELATED CASES

Date April 17, 2015

Title Signal IP v. American Honda Motor Co., Inc. -- AND RELATED CASES

Term No. 29: "All Having the Same Data Format but Distinctive Codes for Tire Transmitters and Vehicle Function Transmitters" (Claim 1)

Plaintiff's Proposal	Defendant's Proposal	Court's Construction
<p>Plain and ordinary meaning.</p> <p>To the extent a construction is necessary, Plaintiff proposes: "All transmitting data in a format compatible with the receiver, with unique codes for tire transmitters and vehicle function transmitters."</p>	<p><u>Mazda, Mitsubishi, Nissan, Subaru:</u></p> <p>"all having the same number and arrangement of data bits or elements but including distinct coded data for tire transmitters and vehicle function transmitters"</p>	<p>"all having the same number and arrangement of data bits or elements but including distinct coded data for tire transmitters and vehicle function transmitters."</p>

The parties dispute the proper construction of "data format," and appear to dispute some nuance around the term "distinctive codes." Jt. Br., Dkt. 53 at 186. Defendants propose that the data format must be the "number and arrangement of data bits" or elements, while Plaintiff argues that any "format compatible with the receiver" is included. *Id.* at 187, 188. Plaintiff's proposed construction also replaces "having the same" with "transmitting," which Defendants contend improperly broadens the scope of the claim. *Id.* at 186.

a. *The Language of the Claim*

Claim 1 covers a "vehicle remote function actuator system" including "at least one remote tire transmitter for transmitting radio frequency tire condition data; at least one remote vehicle function transmitter for transmitting radio frequency vehicle function data . . . the remote transmitters all having the same data format but distinctive codes for tire transmitters and vehicle function transmitters." '374 Patent at 6:35-39, 48-50. The claim does not describe the data format or codes in any further detail.

b. *The Specification*

The specification teaches that the "receiver function [is shared] with another vehicle operation to economize on initial expense as well as upon power requirements." *Id.* at 1:60-62. Confusingly, the specification uses four different "format" terms, and it is inconsistent with respect to "data format" and "message format."

- "The **signal format** of the tire pressure senders is the same as the keyless entry senders. A code in the signal identifies the source of the signal, and the processor handles the signal data accordingly." *Id.* at 2:13-16 (emphasis added).
- "FIG. 4 is an illustration depicting the **data format** of radio communication used in the system." *Id.* at 3:7-8.

UNITED STATES DISTRICT COURT
CENTRAL DISTRICT OF CALIFORNIA

CIVIL MINUTES – GENERAL

Case No. LA CV14-02454 JAK (JEMx) -- AND RELATED CASES

Date April 17, 2015

Title Signal IP v. American Honda Motor Co., Inc. -- AND RELATED CASES

FIG - 4

PREAMBLE	HEADER	ID	SECURITY / PRESSURE DATA	FUNCTION CODE	CHECK SUM
----------	--------	----	--------------------------	---------------	-----------

- “The **data format** is pulse width modulated. Both the **data format** and the **message format** are compatible with that of the fob 16 so that the receiver can consistently manage the data from either source. The **message format as shown in FIG. 4** comprises a preamble which comprises a series of ones; a header one byte long for message byte forming and identifying the source as a tire sender or a keyless entry fob; the unique transmitter identification code which is four bytes long; pressure data including seven bytes of zeros and 1 byte containing pressure measurements from the transducer 50 covering a range of 0 psi to 100 psi; a function code one byte long to denote sign-up, state of health, pressure low or pressure high, and finally a checksum 1 byte long for message verification. For the fob 16 transmission the function code would contain sign-up, door lock, door unlock, trunk open, or light on commands, and the pressure data is replaced by security data which would comprise a code for verifying authenticity of the sending fob.” *Id.* at 4:52-66 (emphasis added).
- “By using a common **communication format** the receiving microprocessor can readily process the incoming data from either source.” *Id.* at 6:22-24 (emphasis added).

Setting aside the terms “signal format” and “communication format,” there is an internal inconsistency in the specification with respect to the use of “data format” and “message format.” First, the specification clearly teaches that the two are not the same: “[b]oth the data format and the message format are compatible with that of the fob” *Id.* at 4:47-49. The surrounding language suggests that “data format” could describe the modulation (“the data format is pulse width modulated”, *id.* at 4:47), while “message format” could describe the arrangement of bytes encoded by the modulation. *Id.* at 4:52-66.

This distinction is then complicated because the specification says that “FIG. 4 is an illustration depicting the **data format** of radio communication used in the system.” *Id.* at 3:7-8 (emphasis added), then that “The **message format** as shown in FIG. 4 comprises a preamble which comprises a series of ones; a header one byte long” *Id.* at 4:52-54. That is, the specification expressly, and contradictorily, teaches that FIG. 4 is an illustration of the “data format” and an illustration of the “message format.”

At the *Markman* hearing, Plaintiff argued that this is a “typo.” “[C]ertain obvious errors in the patent can be corrected by the district court in construing the patent. . . . A district court can correct a patent only if (1) the correction is not subject to reasonable debate based on consideration of the claim language and the specification and (2) the prosecution history does not suggest a different interpretation of the claims.” *Novo Indus., L.P. v. Micro Molds Corp.*, 350 F.3d 1348, 1355, 1357 (Fed. Cir. 2003).

It is not clear how the patent should be “corrected,” i.e., whether “data format” in column 3 would be

UNITED STATES DISTRICT COURT
CENTRAL DISTRICT OF CALIFORNIA

CIVIL MINUTES – GENERAL

Case No. LA CV14-02454 JAK (JEMx) -- AND RELATED CASES

Date April 17, 2015

Title Signal IP v. American Honda Motor Co., Inc. -- AND RELATED CASES

changed to “message format,” or whether “message format” in column 4 would be changed to “data format.” Without deciding that issue, in the context of the claim language, the specification teaches that the transmissions, whether from the tire transmitter or key fob, “all hav[e] the same number and arrangement of data bits or elements but include[e] distinct coded data for tire transmitters and vehicle function transmitters.” Thus, it is appropriate to find that the inclusion in the claim of the term “data format” imparts that same understanding.

c. The Prosecution History

The prosecution history does not bear on this question.

d. The Extrinsic Evidence

Defendants cite a dictionary definition of “format”: “[a] particular arrangement of data or characters in a record, instruction, word, etc., in a form that can be processed or stored by a computer.” *Oxford English Dictionary Online*, JA-0746. Defendants argue that this shows that the data sent must be in “the same format -- i.e., the same number and arrangement of bits.” This definition provides that there are many different possible expressions of a format. Thus, this definition in no way restricts this format to any particular type. The dictionary definition supports Plaintiff’s proposed broad reading of the meaning of “format.”

e. Conclusion

For purposes of claim construction, Defendant’s construction is the most accurate in view of the patent as a whole:

Ultimately, the interpretation to be given a term can only be determined and confirmed with a full understanding of what the inventors actually invented and intended to envelop with the claim. The construction that stays true to the claim language and most naturally aligns with the patent’s description of the invention will be, in the end, the correct construction.

Phillips, 415 F.3d at 1316 (Fed. Cir. 2005) (quoting *Renishaw*, 158 F.3d at 1250). Therefore, the Defendants’ construction is adopted: “all having the same number and arrangement of data bits or elements but including distinct coded data for tire transmitters and vehicle function transmitters.”²⁹

²⁹ Once again, the inconsistent description of various “formats” in the ‘374 Patent could give rise to indefiniteness. Because this issue has not been briefed by the parties, indefiniteness will not be resolved during claim construction. Therefore, the construction is adopted without prejudice to Defendants presenting claims as to indefiniteness at a later stage of the proceedings.

UNITED STATES DISTRICT COURT
CENTRAL DISTRICT OF CALIFORNIA

CIVIL MINUTES – GENERAL

Case No. LA CV14-02454 JAK (JEMx) -- AND RELATED CASES

Date April 17, 2015

Title Signal IP v. American Honda Motor Co., Inc. -- AND RELATED CASES

Term No. 30: "A Switch Activated by a Vehicle User" (Claim 3)

Plaintiff's Proposal	Defendant's Proposal	Court's Construction
Plain and ordinary meaning.	<u>Mazda, Mitsubishi, Nissan, Subaru:</u> "a magnetic switch activated by a permanent magnet operated by a user to identify the location of a particular tire to the processor"	not limited to a magnetic switch further construction not required

Defendants argue that the term should be restricted to a "magnetic switch" activated by a "permanent magnet" to "identify the location of a particular tire to the processor." The bases for this position are the references to that type of switch in the specification and prosecution history. *Jt. Br.*, Dkt. 53 at 190. Plaintiff argues that it would be improper to import such limitations from the specification, and that the references to magnets in the prosecution history do not rise to a disclaimer. *Id.* at 192.

a. *The Language of the Claim*

In claim 3, the system "compris[es]" "a switch activated by a vehicle user for transmitting a sign-up message including the identification code for that tire location." '374 Patent at 7:22-23. The claim does not mention magnets or otherwise restrict the type of switch claimed.

The claim clearly explains that the message transmitted when the switch is activated includes tire location. *Id.* at 7:23-24. This data is transmitted to the receiver unit -- "a radio receiver [is] mounted on the vehicle for receiving data messages from the tire transmitters and lock operation commands from the keyless entry transmitter," and "the receiver unit include[s] means for storing identification codes from the transmitted sign-up messages." *Id.* at 7:12-14, 24-26. Thus, the language of the claim suggests that adding "to identify the location of a particular tire" would be redundant, and to add "to the processor" would be inaccurate.

Claim 6 depends from claim 4. In claim 6, "each tire is equipped with a magnetic switch," and switch activation includes "manually presenting a magnet to each tire in a prescribed rotation for sequentially actuating the magnetic switches." *Id.* at 8:20-21, 23-25. Plaintiff argues that claim differentiation applies; Defendants respond that claim 6 depends from claim 3, not claim 4.

The presence of magnetic switches in claim 6 but not in claim 4 "creates a presumption that each claim . . . has a different scope," *Kraft Foods, Inc. v. Int'l Trading Co.*, 203 F.3d 1362, 1368 (Fed. Cir. 2000). That presumption has the most force only where "the limitation that is sought to be 'read into' an independent claim already appears in a dependent claim." *Liebel-Flarsheim Co. v. Medrad, Inc.*, 358 F.3d 898, 910 (Fed. Cir. 2004). This presumption is rebuttable. *Kraft Foods*, 203 F.3d at 1368.

UNITED STATES DISTRICT COURT
CENTRAL DISTRICT OF CALIFORNIA

CIVIL MINUTES – GENERAL

Case No. LA CV14-02454 JAK (JEMx) -- AND RELATED CASES

Date April 17, 2015

Title Signal IP v. American Honda Motor Co., Inc. -- AND RELATED CASES

b. The Specification

The specification repeatedly refers to the switch as magnetic: (1) “A portable magnet is placed near each tire, in turn, to operate the magnetic switches,” ‘374 Patent Abstract; (2) Figure 3 shows a “sign-up magnetic switch”; and (3) “magnetic switches are used to teach the receiver processor the location of each tire [and a] portable magnet is carried by an operator and placed adjacent each tire in a predetermined sequence.” *Id.* at 2:46-51. The only examples provided use magnetic switches, and a system with magnetic switches is repeatedly referred to as “the invention.” *Id.* at 1:47, 2:46-51, 4:15, 4:25-32.

That the specification never refers to non-magnetic switches is not itself a sufficient basis to overcome the presumption that claim 3 does not contain the limitations present in dependent claim 6. *Liebel-Flarsheim*, 358 F.3d at 906 (the Federal Circuit “has expressly rejected the contention that if a patent describes only a single embodiment, the claims of the patent must be construed as being limited to that embodiment”).

The specification also describes the information going to the processor: “The processor then is apprised of the location of each of the tires and makes a record of that information.” *Id.* at 2:53-56. Nevertheless, it is not necessary to import this language into the claim, which by its express terms requires the information to go to a receiver. A skilled artisan would not doubt that a processor should be implemented to do processing tasks. Further, the open-ended language (“comprising”) allows a processor or equivalent device to be added to those listed in the claim.

c. The Prosecution History

In the original patent application, current claim 3 was designated claim 4 and current claim 6 was designated claim 16. Mar. 27, 1995 Response to Office Action at 2, SIG00000398. In a January 6, 1995 office action, the USPTO rejected claims 4 and 16. Claim 4 was rejected as obvious over U.S. Pat. No. 5,289,369 to Hirshberg (“Hirshberg”) in view of U.S. Pat. No. 5,109,213 to Williams (“Williams”). Claim 16 was rejected as obvious over Hirshberg and Williams in view of U.S. Patent No. 4,163,208 to Merz (“Merz”). Hirshberg is for a car-rental system that keeps track of the location and movement of each car. Hirshberg at Abstract, SIG00000388. The system can also track information about “the main systems of the car, such as fuel level [and] tire pressure.” *Id.* at 2:43-47, SIG00000394. Williams is for a tire pressure monitor using tire pressure sensors with manual (“DIP”) switches for identifying the source tire. Williams at Abstract, SIG00000332, 3:61-4:31, SIG00000344. Merz is for an automatic wireless tire pressure monitoring system using directional antennas and different frequencies for identifying the source tire (or foregoing tire identification entirely). Merz at Abstract, SIG00000318, 7:35-66, SIG00000330.

In responding to this office action, the applicant added the phrases “switch activated by a vehicle user” and “transmitting a sign-up message.” As the applicant explained: “Claims 4, 16 and 17 are additionally directed to the Applicants’ “magnetic sign-up” feature. Representative Claim 4 provides . . . : ‘a switch activated by a vehicle user for transmitting a sign-up message’” Mar. 27, 1995 Response to Office Action at 2, 5, SIG00000398-401. Nothing added to or quoted in claim 4 relates to magnets.

UNITED STATES DISTRICT COURT
CENTRAL DISTRICT OF CALIFORNIA

CIVIL MINUTES – GENERAL

Case No. LA CV14-02454 JAK (JEMx) -- AND RELATED CASES

Date April 17, 2015

Title Signal IP v. American Honda Motor Co., Inc. -- AND RELATED CASES

In justifying the allowance of claims 16 and 17, the applicant argued about details of the identification codes and their transmission, while characterizing both inventions as ones that use magnetic switches. *Id.* at 5-6, SIG00000401-02. The response concluded: “Applicants have amended Claims 4 and 16 to clearly provide that the magnetic switches in the sign-up procedure are activated by the operator of the vehicle to transmit identification codes which are stored by the receiver for comparison with subsequently transmitted tire pressure signals to differentiate pressure data transmitted from various tire locations.” *Id.* at 7, SIG00000403.

This history shows that the applicant represented to the USPTO that current claim 3 involved magnetic switches. However, the reference to the magnetic nature of the switches was in passing, and no argument was made that the magnetic nature of the switch distinguished the invention from the prior art. Indeed, given that then-claim 16, also referred to, expressly recites a magnetic switch, this could have been an oversight. “[A]lleged disavowing actions or statements made during prosecution [must] be both clear and unmistakable.” *Omega Eng’g, Inc. v. Raytek Corp.*, 334 F.3d 1314, 1326 (Fed. Cir. 2003). The cited statements are insufficient to rebut the presumption that claim 3 does not require a magnetic switch. See *Storage Technology Corp. v. Cisco Systems, Inc.*, 329 F.3d 823, 832 (Fed. Cir. 2003) (holding that statement in prosecution history that in “the invention as recited in claims 1, 11, and 18, the instance of network policy and the policy identification information are both cached” was insufficient to require caching in the independent claim: “The prosecution history statement describes generally the features of the claimed invention and erroneously suggests that the independent claims include a cache for the instance of network policy. The applicants’ inaccurate statement cannot override the claim language itself, which controls the bounds of the claim.”).

d. The Extrinsic Evidence

The extrinsic evidence does not bear on this question.

e. The Conclusion

Claim 3 is not limited to a magnetic switch. The term does not otherwise require construction.

Term No. 31: “Sign Up Message” (Claim 3)

Plaintiff’s Proposal	Defendant’s Proposal	Court’s Construction
Plain and ordinary meaning. To the extent a construction is necessary, Plaintiff proposes: “A message that identifies the tire.”	<u>Mazda, Mitsubishi, Nissan, Subaru</u> : “a coded signal transmitted from a tire pressure sensor to a processor that identifies the specific location of the tire on the vehicle”	None required.

The parties agree that the sign-up message identifies each tire by its location. Defendants propose that

UNITED STATES DISTRICT COURT
CENTRAL DISTRICT OF CALIFORNIA

CIVIL MINUTES – GENERAL

Case No. LA CV14-02454 JAK (JEMx) -- AND RELATED CASES

Date April 17, 2015

Title Signal IP v. American Honda Motor Co., Inc. -- AND RELATED CASES

the message must be “transmitted from a tire pressure sensor to a processor.” Jt. Br., Dkt. 53 at 193-94. Plaintiff argues that this is inappropriate because the sign up message is transmitted by a user to a receiver. Defendants’ proposed construction also describes a “coded signal,” which Plaintiff argues is not described anywhere in the ‘374 Patent. *Id.* at 195-96.

a. *The Language of the Claims*

The switch in claim 3 is used “for transmitting a sign-up message including the identification code for that tire location.” ‘374 Patent at 7:23-24. This indicates that the signal would be accurately described as “coded.”

The switch is “activated by a vehicle user.” *Id.* at 7:22-23. The data is “transmitted from various tire locations,” through “a set of remote transmitters comprising radio frequency tire transmitters one mounted in each tire.” *Id.* at 7:28, 7:5-6. Defendants propose that this means the signal is “transmitted from a tire pressure sensor.” Jt. Br., Dkt. 53 at 193. Plaintiff argues that the “claim recites that the sign-up message is transmitted by ‘a switch activated by a vehicle user.’” *Id.* at 196. The claim does not mention sensors. It does describe a “controller coupled with each tire transmitter having a pressure detector,” but this is not discussed in conjunction with the “sign-up message.” ‘374 Patent at 7:19-24. Claim 3 teaches that the sign-up message carries “the identification code for that tire location,” *Id.* at 7:23-24; this supports Plaintiff’s proposal.

A receiver unit includes a “means for storing identification codes from the transmitted sign-up messages for comparison with subsequently transmitted data messages to differentiate data transmitted from various tire locations.” *Id.* at 25-28. Defendants argue that a processor identifies the location of each tire, Jt. Br., Dkt. 53 at 195, while Plaintiff argues that the claim shows that a receiver unit does this task. *Id.* at 196. The claim only mentions a “receiver” in connection with receiving and processing the sign-up message. By contrast, the claim describes a “processor coupled with the receiver . . . for controlling the locks.” *Id.* at 7:19-24, 7:15-18.

b. *The Specification*

Figure 3 of the ‘374 Patent, which is reproduced below, shows a schematic diagram of the tire pressure sender of Figure 1. ‘374 Patent at 3:5-6. Figure 3 includes a “sign-up magnetic switch 47.” *Id.* at 3:65-66.

UNITED STATES DISTRICT COURT
CENTRAL DISTRICT OF CALIFORNIA

CIVIL MINUTES – GENERAL

Case No. LA CV14-02454 JAK (JEMx) -- AND RELATED CASES

Date April 17, 2015

Title Signal IP v. American Honda Motor Co., Inc. -- AND RELATED CASES

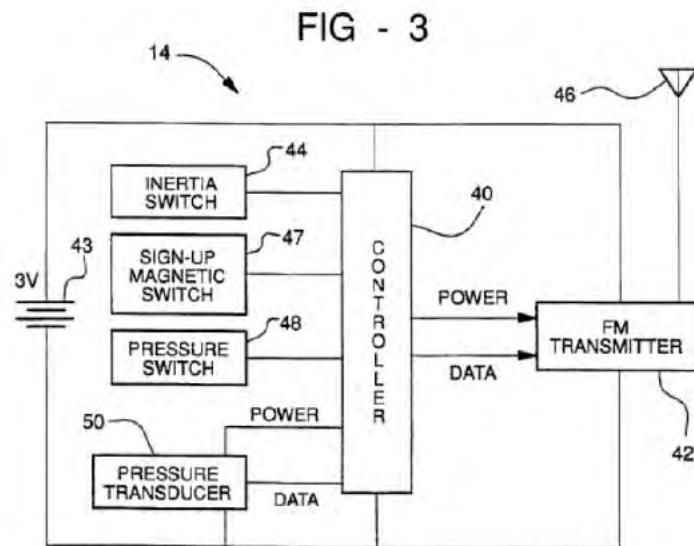

The sign-up magnetic switch 47 is operated by placing the magnet 36 near the tire. When a magnetic switch is actuated the controller is awakened and causes a sign-up code as well as the identification code to be sent to the transmitter 42 and then to the actuator 18. By moving the magnet from one tire to another in a prescribed sequence, the resulting sequence of transmissions enables the actuator to determine the position of each sender 14.

Id. at 4:25-32. Defendants argue that this information, including a “sign-up code as well as an identification code,” is “indisputably a coded signal.” *Jt. Br.*, Dkt. 53 at 194. However, the connotations of a code and a coded signal are not necessarily the same, and Defendants have not justified treating them interchangeably.

In Defendants’ proposed construction, the sign-up message is transmitted from a tire pressure sensor. However, the specification shows the information having been sent from a tire pressure “sender,” not a tire pressure “sensor.” ‘374 Patent at 2:56-59, 3:41, 55, 6:27-28.

Finally, Defendants propose that “a processor . . . identifies the specific location of the tire on the vehicle.” *Jt. Br.*, Dkt. 53 at 193. The relevant part of the specification states:

As each switch opens or closes it wakes up its associated controller to transmit the identification code to the receiver. The processor then is apprised of the location of each of the tires and makes a record of that information. Then each time a low pressure or other signal is received from a tire pressure sender the processor can identify the tire position where the data originated.

‘374 Patent at 2:52-59. Further, “[t]he processor is a microprocessor having a receiver-on port for

UNITED STATES DISTRICT COURT
CENTRAL DISTRICT OF CALIFORNIA

CIVIL MINUTES – GENERAL

Case No. LA CV14-02454 JAK (JEMx) -- AND RELATED CASES

Date April 17, 2015

Title Signal IP v. American Honda Motor Co., Inc. -- AND RELATED CASES

sending a command to the receiver and a data port for accepting data from the receiver.” *Id.* at 3:44-47. As this language shows, the receiver receives the information, and sends it to a processor, which further analyzes the data.

c. The Prosecution History and the Extrinsic Evidence

The prosecution history and extrinsic evidence do not bear on this question.

d. Conclusion

In the context of the claim, “sign up message” is clear and requires no construction. Defendants have not justified importing into the claim specific details in the specification surrounding the exemplary embodiments of how a “sign up message” is used.

Term No. 32: “Each Tire” (Claim 3)

Plaintiff’s Proposal	Defendant’s Proposal	Court’s Construction
Plain and ordinary meaning. To the extent a construction is necessary, Plaintiff proposes: “Each tire subject to tire pressure monitoring.”	<u>Mazda, Mitsubishi, Nissan, Subaru:</u> “each tire inclusive of any spare tire”	“each tire inclusive of any spare tire”

a. The Language of the Claim

In claim 3, the system includes “a set of remote transmitters comprising radio frequency tire transmitters one mounted in each tire for transmitting data messages including modulated data and an identification code.” ‘374 Patent at 7:5-8. The claim does not further define “each tire.”

b. The Specification

The specification states that “[t]he magnet switches are used to teach the receiver processor the location of each tire on the vehicle, including the spare tire.” *Id.* at 2:46-48. Figure 1, which is reproduced below, with annotations added, shows a schematic diagram of the system. *Id.* at 3:1-2. Figure 1 shows senders 14 in both the four installed tires and in the spare tire that is stored in the trunk.

UNITED STATES DISTRICT COURT
CENTRAL DISTRICT OF CALIFORNIA

CIVIL MINUTES – GENERAL

Case No. LA CV14-02454 JAK (JEMx) -- AND RELATED CASES

Date April 17, 2015

Title Signal IP v. American Honda Motor Co., Inc. -- AND RELATED CASES

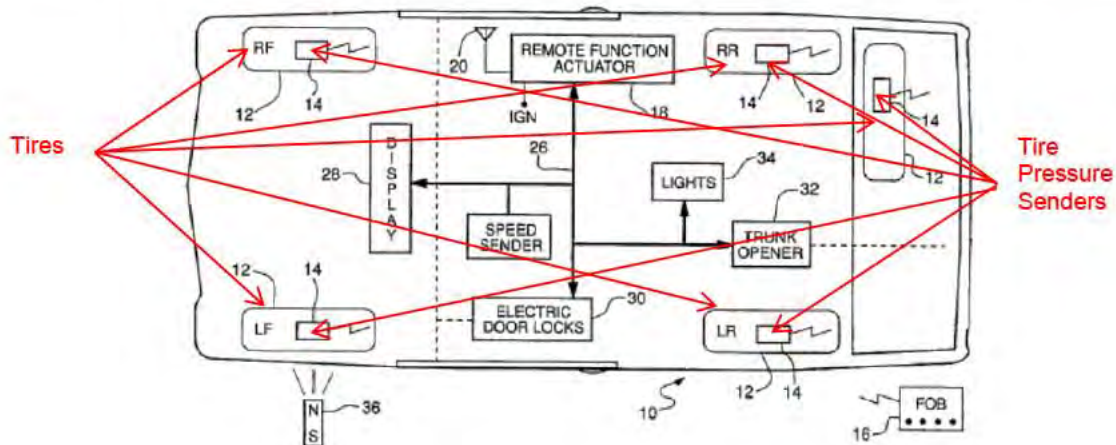

The sign up process is done “according to a prescribed sequence, say, LF, RF, RR, LR, and then Spare.” *Id.* at 5:57-59. “Any time the tire positions are changed for tire rotation or exchanging a tire of the spare, the sign-up procedure must be repeated to update the . . . record of tire positions.” *Id.* at 6:16-19. The specification describes each tire being relevant for the claimed messages, inclusive of spares.

Plaintiff argues that, because the specification mentions “a spare tire in the vehicle trunk,” this only applies to an inflated tire in the trunk, and that spare tires only need transmitters when “subject to tire pressure monitoring.” *Jt. Br.*, Dkt. 53 at 199. Plaintiff’s argument is circular, and reads out “each tire” from the claim.

In sum, the specification supports Defendants’ proposed requirement that any spare tire is included.

c. The Prosecution History and the Extrinsic Evidence

The prosecution history and extrinsic evidence do not bear on this question.

d. Conclusion

For the foregoing reasons, the construction “each tire inclusive of any spare tire” is adopted.

G. The ‘775 Patent³⁰

The ‘775 Patent was issued to assignee Delco on September 21, 1999. It discloses a dual rate communication protocol to improve the communication of seat content data to an airbag system. ‘775 Patent at Abstract. The ‘775 Patent contains eight claims, one of which Plaintiff asserts. *Joint Rep.*, Dkt.

³⁰ The ‘775 Patent is provided as Exhibit X, JA-0749-54.

UNITED STATES DISTRICT COURT
CENTRAL DISTRICT OF CALIFORNIA

CIVIL MINUTES – GENERAL

Case No. LA CV14-02454 JAK (JEMx) -- AND RELATED CASES

Date April 17, 2015

Title Signal IP v. American Honda Motor Co., Inc. -- AND RELATED CASES

35 at 4. Defendants request construction of four terms, and contend that two of them are indefinite. *Jt. Br.*, Dkt. 53 at 200, 204, 221, 223.

The '775 Patent teaches that it is desirable to transmit multiple types of information, such as weight and position information, from seat sensors. '775 Patent at 2:21-24. The invention claimed in the '775 patent allows communication at low and high bandwidths over the same communication link. *Id.* at 2:21-23. High and low bandwidths may be used separately or in combination. *Id.* at 2:21-29. This is shown in Figure 1 of the '775 Patent, which is reproduced below, with annotation added.

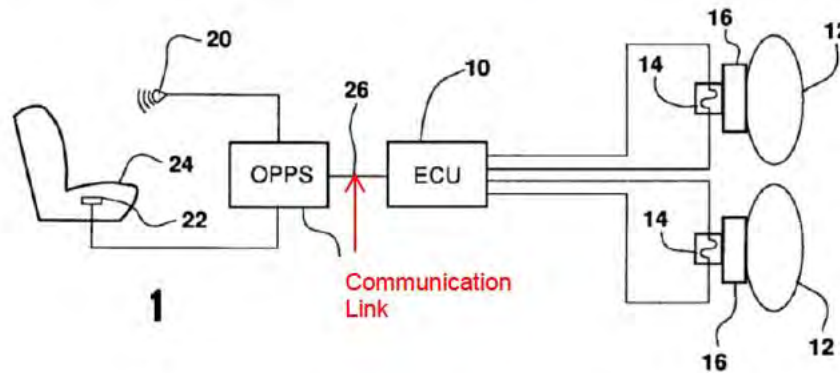

Figure 1 -- Schematic Diagram of System

An electronic control unit (ECU) is coupled to air bags and a device used to determine both the presence of an occupant as well as position sensing (OPSS). *Id.* at 3:20-27. Information from the OPSS is encoded as digital data and transmitted over a communication link to the ECU, which determines whether to deploy an air bag. *Id.* at 3:31-35.

The OPSS device transmits information about both the presence and position of an occupant. *Id.* at 3:26-31. Presence data is updated slowly, while position data is updated frequently and rapidly. *Id.* at 3:36-37. Thus, the two types of data constitute component protocols within a combined one. *Id.* at 3:38-42. Each component protocol is based on a fundamental time interval (FTI) -- a low rate FTI (LFTI) for the occupant presence component, and a high rate FTI (HFTI) for the occupant position component. *Id.* at 3:36-46. The ratio of the LFTI to the HFTI allows at least one complete high rate message to be contained within one LFTI. At the same time there is sufficient time remaining within the LFTI to determine its state unambiguously, as shown in Figure 2 of the '775 Patent (below). *Id.* at 3:47-51. Within a given low rate message period, there are multiple high rate time intervals, providing sufficient bandwidth to contain at least one complete message. *Id.* at 3:57-60.

UNITED STATES DISTRICT COURT
CENTRAL DISTRICT OF CALIFORNIA

CIVIL MINUTES – GENERAL

Case No. LA CV14-02454 JAK (JEMx) -- AND RELATED CASES

Date April 17, 2015

Title Signal IP v. American Honda Motor Co., Inc. -- AND RELATED CASES

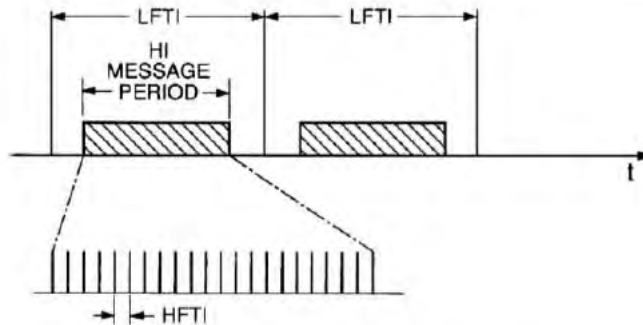

Figure 2 -- Combined High Rate and Low Rate Message Protocols

In an exemplary embodiment, the LFTI is 50 ms and the HFTI is 500 μ s. A high rate message using 54 FTIs would require 27 ms and fit within the LFTI without ambiguity. *Id.* at 4:11-17. A value of 0 is denoted by a pulse one FTI wide and a value of 1 is denoted by a pulse two FTI wide. *Id.* at 4:23-25. Figure 3 of the '775 Patent shows an exemplary message. *Id.*

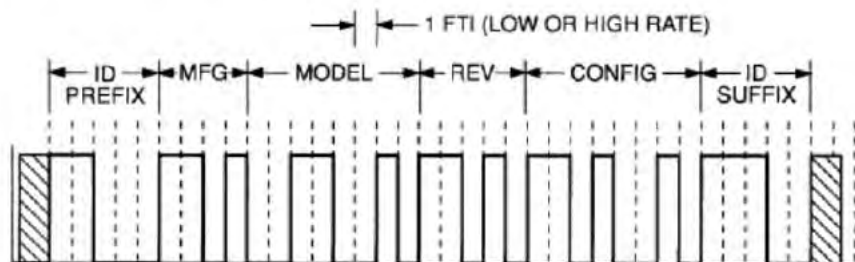

Figure 23 -- Exemplary Message

The asserted '775 Patent claim is reproduced below, with the disputed terms in bold:

6. A method of accommodating communication of first and second types of data at first and second **message rates** over a common communication link comprising the steps of:
 - establishing a **message rate interval** on the common communication link;
 - devoting a portion of each **message rate interval** to the first type of data and reserving a remaining portion of each **message rate interval** for the second type of data;
 - providing the first type of data at a first **message rate** sufficient to form a **complete message** within the devoted portion of each **message rate interval**;
 - providing the second type of data at a second **message rate** sufficient to form only a **fragment of a complete message** in the remaining portion of each **message rate interval**, thereby requiring a plurality of consecutive **message rate intervals** to form a **complete message** of the second type of data; and

UNITED STATES DISTRICT COURT
CENTRAL DISTRICT OF CALIFORNIA

CIVIL MINUTES – GENERAL

Case No. LA CV14-02454 JAK (JEMx) -- AND RELATED CASES

Date April 17, 2015

Title Signal IP v. American Honda Motor Co., Inc. -- AND RELATED CASES

transmitting at least one of the first and second types of data in the respective portions of each message rate interval.

Term No. 33: "Message Rate" (Claim 6)

Plaintiff's Proposal	Defendant's Proposal	Court's Construction
<p>Plain and ordinary meaning.</p> <p>To the extent a construction is necessary, Plaintiff proposes: "The data rate at which messages are sent, which <i>may be</i> expressed in terms of a number of bits or bytes transmitted per second."</p>	<p><u>BMW, Mercedes:</u></p> <p>"the data rate at which messages are sent, which <i>is</i> expressed in terms of a number of bits or bytes transmitted per second"</p>	<p>"The data rate at which messages are sent, which may be expressed in terms of a number of bits or bytes transmitted per second."</p>

The parties agree that the term "message rate" refers to "the data rate at which messages are sent." *Jt. Br.*, Dkt. 53 at 200. But, BMW and Mercedes argue the message rate "*is* expressed in terms of a number of bits or bytes transmitted per second;" Plaintiff responds that the message rate "*may be*" expressed that way. *Id.*

a. The Language of the Claim

Claim 6, in its entirety, is: "A method of accommodating communication of first and second types of data at first and second message rates over a common communication link comprising the steps of:

- establishing a message rate interval on the common communication link;
- devoting a portion of each message rate interval to the first type of data and reserving a remaining portion of each message rate interval for the second type of data;
- providing the first type of data at a first message rate sufficient to form a complete message within the devoted portion of each message rate interval;
- providing the second type of data at a second message rate sufficient to form only a fragment of a complete message in the remaining portion of each message rate interval, thereby requiring a plurality of consecutive message rate intervals to form a complete message of the second type of data; and
- transmitting at least one of the first and second types of data in the respective portions of each message rate interval.

'775 Patent at 6:26-45.

Thus, claim 6 repeatedly refers to "message rates" and a "message rate interval," without suggesting the definition of the term or its appropriate units of measurement.

UNITED STATES DISTRICT COURT
CENTRAL DISTRICT OF CALIFORNIA

CIVIL MINUTES – GENERAL

Case No. LA CV14-02454 JAK (JEMx) -- AND RELATED CASES

Date April 17, 2015

Title Signal IP v. American Honda Motor Co., Inc. -- AND RELATED CASES

b. The Specification

The system uses a “combined protocol,” with two components using different fundamental time intervals (FTIs) -- a low rate fundamental time interval (LFTI) and a high rate fundamental time interval (HFTI). *Id.* at 2:38-40, 3:43-46. The fundamental time interval is “the shortest meaningful time interval for that protocol.” *Id.* at 2:46-47. “The low and high rate protocols are combined when the FTI for the high rate protocol is selected so that an entire high rate message can be contained within a single FTI for the low rate protocol.” *Id.* at 2:38-51. For example, the LFTI is 50 ms and the HFTI is 500 μ s. *Id.* at 4:13-14. “Then a high rate message comprising 54 FTIs will require only 27 ms and the remainder of the LFTI will be in a state required for the low rate message.” *Id.* at 4:11-16. Figure 3 (reproduced below) shows an exemplary message.

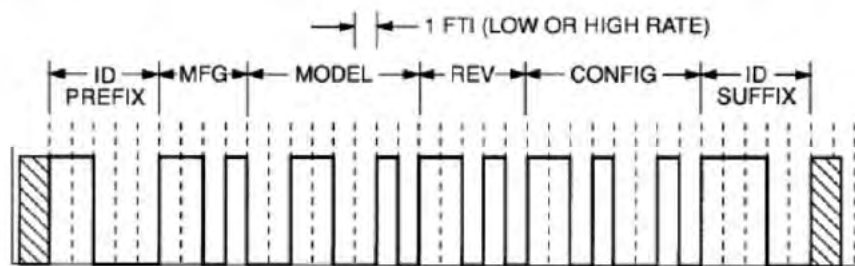

The low rate message requires “two to four LFTIS or 100 ms to 200 ms.” *Id.* at 4:43-44. The high rate message “is more complex,” requiring a “maximum of 54 HFTIs or 27 ms.” *Id.* at 4:48-62. Because the number of messages that fit in a given interval is a function of their message rate, and because the interval is measured in units of time, it appears the message rate is 1 divided by the amount of time it takes to send the data.

In addition, the specification describes the message in terms of bits -- “the ID consists of a 3 bit manufacturer code, a 5 bit model identifier,” etc. *Id.* at 4:27-28. “The same message structure is used for the high rate and the low rate protocols,” *id.* at 4:27-30; “there is a dramatic difference in the information rate or bandwidth required between occupant presence and occupant position systems.” *Id.* at 1:64-67. This indicates that the message rate could also be described as a number of bits per unit of time.

Considered collectively, this language in the specification supports Plaintiff’s interpretation that the message rate can be measured in different units, and does not support Defendants’ attempt to limit it to “bits or bytes transmitted per second.”

c. The Prosecution History

The prosecution history does not bear on this question.

UNITED STATES DISTRICT COURT
CENTRAL DISTRICT OF CALIFORNIA

CIVIL MINUTES – GENERAL

Case No. LA CV14-02454 JAK (JEMx) -- AND RELATED CASES

Date April 17, 2015

Title Signal IP v. American Honda Motor Co., Inc. -- AND RELATED CASES

d. The Extrinsic Evidence

Defendants’ expert, Dr. Philip Koopman, opines that a skilled artisan would understand “message rate” to mean “the data rate at which messages are sent, which is expressed in terms of bits/second.” Koopman Decl. at ¶ 28, JA-0765. Plaintiff’s expert Smedley disagrees, asserting that there is “no support in the specification for reading in a particular way in which that data rate must be expressed,” and “bits/second . . . is by no means the only . . . way of expressing a message rate.” Smedley Decl. at ¶ 21, JA-0313.

In his deposition, Smedley testified that bits per second is “one of many widely used ways of talking about a data rate,” and it could also be referenced in “nonquantitative ways like . . . a very high rate or a very low rate . . . or . . . in terms of how many videos you can download . . . or . . . in terms of kilobytes per hour or megabits per second. . . . It’s also sometimes described as a baud rate.” Smedley Depo. at 53:15-54:21, JA-0335-36. He noted that all the quantitative units listed were “closely related to bits per second,” i.e. “you can convert from one to the other.” *Id.*

Defendants argue that all of the quantitative units listed by Smedley are equivalent to bits per second, citing a dictionary definition of “baud rate”: “[t]he baud . . . indicates the number of bits per second that are transmitted.” *Random House Webster’s Computer & Internet Dictionary* 48 (3d ed. 1999), JA-0870.

The extrinsic evidence suggests that message rate intervals are typically measured in bits per second, or are at least convertible to that measurement.

e. Conclusion

Because the parties generally agree on Plaintiff’s proposed construction, save the unnecessary restriction that the data rate must always be measured in a specific unit, the following construction is adopted: “The data rate at which messages are sent, which may be expressed in terms of a number of bits or bytes transmitted per second.”

Term No. 34: “Message Rate Interval” (Claim 6)

Plaintiff’s Proposal	Defendant’s Proposal	Court’s Construction
<p>Not indefinite.</p> <p>Plain and ordinary meaning.</p> <p>To the extent a construction is necessary, Plaintiff proposes: “A period of time corresponding to a message rate.”</p>	<p><u>Mercedes and VW / Bentley:</u> Indefinite</p> <p><u>Mercedes Alternative:</u> “a period of time sufficiently long to contain both first and second types of data”</p> <p><u>BMW:</u> “The fundamental time interval of the first (low rate) message rate protocol”</p>	<p>Not indefinite.</p> <p>Construction not required.</p>

UNITED STATES DISTRICT COURT
CENTRAL DISTRICT OF CALIFORNIA

CIVIL MINUTES – GENERAL

Case No. LA CV14-02454 JAK (JEMx) -- AND RELATED CASES

Date April 17, 2015

Title Signal IP v. American Honda Motor Co., Inc. -- AND RELATED CASES

Mercedes and VW/Bentley argue that the term “message rate interval” is indefinite. *Jt. Br.*, Dkt. 53 at 204. Mercedes bases its argument upon the intrinsic evidence and the testimony of Dr. Koopman, while VW/Bentley base their argument on the intrinsic evidence alone. *Id.* at 204, 210-212.

BMW does not contend that the term is indefinite, and proposes that “message rate interval” corresponds to the low rate message protocol only. *Id.* at 213. Plaintiff argues that the term is not confined to the low message rate protocol, and that it is not indefinite. *Id.* at 215, 217.

a. The Language of the Claim

In claim 6, the steps include “establishing a message rate interval on the common communication link” and “devoting a portion of each message rate interval to the first type of data and reserving a remaining portion of each message rate interval for the second type of data” such that it is possible “to form a complete message within the devoted portion of each message rate interval.” ‘775 Patent at 6:26-36. The “second type of data” is provided “at a second message rate sufficient to form only a fragment of a complete message in the remaining portion of each message rate interval, thereby requiring a plurality of consecutive message rate intervals to form a complete message of the second type of data.” *Id.* at 6:37-42. The “first and second types of data” are transmitted “in the respective portions of each message rate interval.” *Id.* at 6:43-45.

This claim language indicates that the “message rate interval” is simply an interval of time for messages, to be apportioned as expressly called for in the claim. VW/Bentley and Mercedes argue that the term is indefinite because it only appears in the claim and does not have a known meaning in the art. *Jt. Br.*, Dkt. 53 at 205. However, the claim itself describes in considerable detail what is required of the message rate interval.

b. The Specification

The system uses a “combined protocol,” in which two components use different fundamental time intervals (FTIs) -- a low rate fundamental time interval (LFTI) and a high rate fundamental time interval (HFTI). ‘775 Patent at 2:38-40, 3:43-46. The fundamental time interval is “the shortest meaningful time interval for that protocol.” *Id.* at 2:46-47. “The low and high rate protocols are combined when the FTI for the high rate protocol is selected so that an entire high rate message can be contained within a single FTI for the low rate protocol.” *Id.* at 2:38-51. A “high rate message comprising 54 FTIs will require only 27 ms and the remainder of the LFTI will be in a state required for the low rate message.” *Id.* at 4:11-16. Figure 3, which is reproduced below, illustrates an example of such a message.

UNITED STATES DISTRICT COURT
CENTRAL DISTRICT OF CALIFORNIA

CIVIL MINUTES – GENERAL

Case No. LA CV14-02454 JAK (JEMx) -- AND RELATED CASES

Date April 17, 2015

Title Signal IP v. American Honda Motor Co., Inc. -- AND RELATED CASES

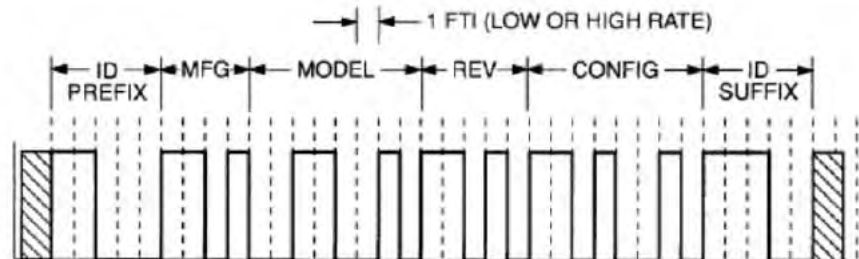

The parties agree that the LFTI is a message rate interval, as shown in the figure below. Plaintiff's Claim Construction Presentation at 143; Defendants' Technology Tutorial at Ch. 17, 4:11.

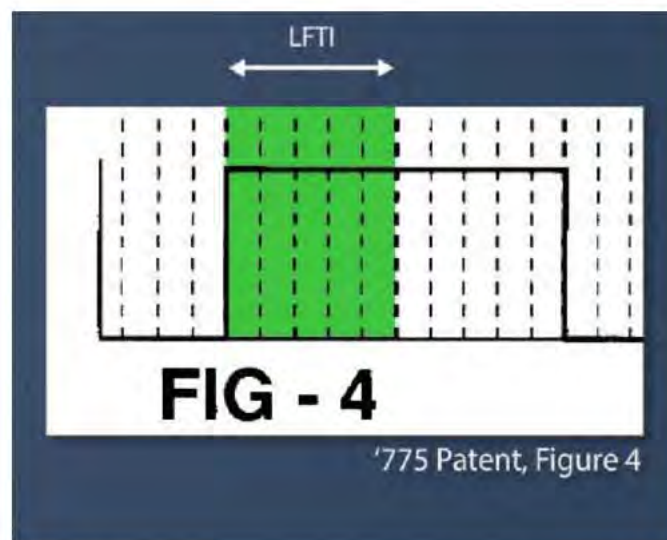

VW/Bentley and Mercedes argue that the description in the patent does not provide sufficiently precise boundaries for the scope of the claim, Jt. Br., Dkt. 53 at 205. In support of this position they observe that the specification gives the example of a 50 ms LFTI and a 500 μ s HFTI, but no other boundaries for the interval. *Id.* at 205-207 (citing '775 Patent at 4:12-13). However, the claim itself precisely specifies how the message rate interval is used and how it must relate to "first" and "second" types of data.

BMW disagrees, and argues that the specification clearly restricts the message rate interval to the LFTI, Jt. Br., Dkt. 53 at 212-13. Defendants' presentation materials, which include the figure reproduced below, show the high rate message in red. In the illustration it fits completely within the LFTI. The low rate message, which is outlined in blue, does not fit within the LFTI. Defendants' Presentation Material, *Signal IP, Inc. v. Mercedes-Benz USA, LLC*, No. LA CV14-3109, Dkt. 66 at 326. BMW argues that this shows that the LFTI is the "message rate interval" because, according to the claim, a complete message of the "first type of data" fits within the message rate interval, and "only a fragment of a

UNITED STATES DISTRICT COURT
CENTRAL DISTRICT OF CALIFORNIA

CIVIL MINUTES – GENERAL

Case No. LA CV14-02454 JAK (JEMx) -- AND RELATED CASES

Date April 17, 2015

Title Signal IP v. American Honda Motor Co., Inc. -- AND RELATED CASES

complete message” of the “second message rate” fits in “the remaining portion of each message rate interval.” *Id.* at 323-27; ‘775 Patent at 6:34-42.

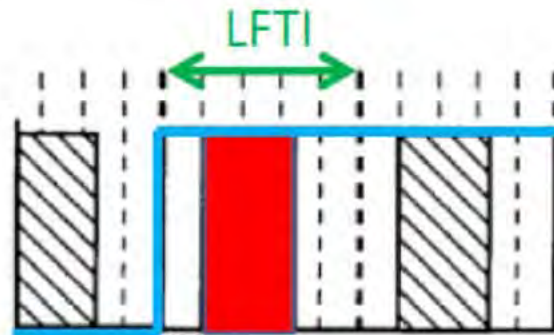

FIG - 7

In the alternative, Mercedes proposes the construction “a period of time sufficiently long to contain both first and second types of data.” For the reasons stated above, this is not accurate because the second type of data (low-rate in the specification) is not intended to fit in the message rate interval, at least if the proposal contemplates a complete message.

Plaintiff disagrees with the interpretations of BMW and VW/Bentley. Plaintiff argues that “the claimed ‘message rate interval’ simply refers to the ‘message rate’ protocols (e.g. high or low) and the corresponding fundamental time ‘intervals’ (i.e. periods of time) in which the protocols are based.” *Id.* at 217.

The specification describes two different types of fundamental time intervals. Although the claim language is supported by the example of the LFTI in the specification, there is not sufficient support to restrict the claim to the low rate interval solely because the patentee intentionally left language about low rate intervals and high rate intervals out of claim 6.

c. The Prosecution History

Claim 6 originally recited “establishing a low message rate interval” and “devoting a period of each interval to high rate message data and reserving the remainder of each interval for low rate information.” Claims as of Feb. 5, 1997, SIG00001130. In a January 8, 1999 office action, the examiner allowed claim 6. Jan. 8, 1999 Office Action at 2, SIG00001143. Claims 6-9 were apparently rejected as obvious in a subsequent phone conference. See Apr. 05, 1999 Amendment at 7, SIG00001205; Defendants’ Presentation Material, *Signal IP, Inc. v. Mercedes-Benz USA, LLC*, No. LA CV14-3109, Dkt. 66 at 328. The applicant then amended claim 6, by removing references to “low” and “high” message rate intervals. In particular, “establishing a low message rate interval” was changed to “establishing a message rate interval on the common communication link,” and, “devoting a period of each interval to high rate message data and reserving the remainder of each interval for low rate

UNITED STATES DISTRICT COURT
CENTRAL DISTRICT OF CALIFORNIA

CIVIL MINUTES – GENERAL

Case No. LA CV14-02454 JAK (JEMx) -- AND RELATED CASES

Date April 17, 2015

Title Signal IP v. American Honda Motor Co., Inc. -- AND RELATED CASES

information” was changed to “devoting a portion of each message rate interval to the first type of data and reserving a remaining portion of each message rate interval for the second type of data.” Apr. 05, 1999 Amendment at 4, SIG00001202. Thus, the applicant broadened the term, but it remained clear that an example of a “first type of data” is the high rate message, and an example of the “second type of data” is the low rate message.

VW/Bentley argue that “the claim was . . . amended to eliminate the references to the ‘high’ and ‘low’ message rates and time intervals in favor of generic claim language, including a ‘message rate interval,’ thereby disclaiming that this ‘message rate interval’ is the same thing as an HFTI or an LFTI.” Jt. Br., Dkt. 53 at 206. However, Plaintiff does not propose that the term is the “same thing” as an HFTI or LFTI.

According to BMW, the prosecution history confirms that the message rate is tied to the LFTI because the amendment was in response to a rejection relating to the high and low rate messages. Jt. Br., Dkt. 53 at 214. However, the amendment serves to broaden the claim, and there is no argument in the prosecution history supporting BMW’s contention. If anything, the prosecution history shows that the patentee chose not to restrict the message rate interval to the LFTI.

Although the prosecution history establishes a connection between the LFTI, HFTI, and message rate interval, the patentee chose to use broader language, which the examiner permitted.

*d. The Extrinsic Evidence*³¹

According to Dr. Koopman, who is Defendants’ expert, “‘message rate interval’ is not a term of art, because it has no commonly understood meaning . . . in any networking field.” Koopman Decl. at ¶ 36, JA-0767. Koopman opines that “message rate” means “data rate” and can be expressed in bits/second. The “interval” is a period of time, expressed in seconds. Thus, the “message rate interval” can be expressed as:

$$\text{message rate interval} = (\text{message rate}) \bullet (\text{interval})$$

In terms of units, this would be

$$[1 \text{ Mbit} / \text{s}] \bullet [\text{s}] = \text{Mbit}$$

According to Koopman, this “does not make any logical sense in the context of the patent-in-suit” because “a number of bits of data is not considered an ‘interval’ in any networking field.” *Id.* at ¶ 38, JA-0767.

Plaintiff agrees with Defendants’ expert that a number of bits is not considered an interval in any networking field, but argues that Koopman’s deduction of the message rate interval into bits is incorrect. Jt. Br., Dkt. 53 at 218-19. Smedley, who is Plaintiff’s expert, opines that, [a]lthough bits/second is one

³¹ VW/Bentley argue that the expert testimony should not be considered. Because the understanding of a skilled artisan is relevant on this issue, the extrinsic evidence is considered.

UNITED STATES DISTRICT COURT
CENTRAL DISTRICT OF CALIFORNIA

CIVIL MINUTES – GENERAL

Case No. LA CV14-02454 JAK (JEMx) -- AND RELATED CASES

Date April 17, 2015

Title Signal IP v. American Honda Motor Co., Inc. -- AND RELATED CASES

way of expressing a message rate, it is by no means the only one.” Smedley Decl. at ¶ 21, JA-0313. According to Smedley, the reason that the resulting unit of Mbit does not make any sense is “that it did not make sense for Dr. Koopman to analyze the term ‘message rate interval’ as if it were a mathematical formula.” *Id.* at ¶ 23, JA-0131-14. Plaintiff explains that the phrase “message rate interval” should not be analyzed formulaically, *id.* at ¶ 22, JA-0313, “because a message rate interval does not refer to a unit of data but rather an interval of time.” *Jt. Br.*, Dkt. 53 at 216.

Smedley cites the following part of the specification in support of his position: “Each component protocol must be based on a fundamental time interval (FTI); a low rate FTI (LFTI) for the occupant presence component, and a high rate FTI (HFTI) for the occupant position component.” ‘775 Patent at 3:43-46; Smedley Decl. at ¶ 29, JA-0315. According to Smedley, “[a] message rate protocol is based on a time interval, and a ‘message rate interval’ simply describes the time interval upon which a protocol for a message rate is based.” Smedley Decl. at ¶ 30, JA-0315. At his deposition, Smedley testified that the fundamental time interval is one possible message rate interval, “but there may well be others.” Smedley Depo. at 114, JA-0351.

e. Conclusion

The meaning of “message rate interval” is reasonably certain from the claim and the specification, and is not indefinite. Because the claim itself describes in detail how the “message rate interval” must relate to the “first and second types of data,” construction is not required.

Term No. 35: “Message” (Claim 6)

Plaintiff’s Proposal	Defendant’s Proposal	Court’s Construction
Plain and ordinary meaning. To the extent a construction is necessary, Plaintiff proposes: “A collection of bits that are sent together in a message protocol.”	<u>BMW</u> : “A collection of bits that are sent together to define the information transferred in a message protocol”	None required.

a. The Language of the Claim

Claim 6 repeatedly refers to a “message,” primarily in the context of “message rate[s]” and “message rate interval[s]” for use in “accommodating communication of first and second types of data.” ‘775 Patent at 6:26-45.

b. The Specification

The specification describes two types of messages, high rate and low rate. ‘775 Patent at Abstract. The high rate message is “more complex,” as shown in Figure 5 of the ‘775 patent (reproduced below). *Id.* at 4:49-50. There is a start of message symbol comprising a low pulse and a high pulse, a 3 bit tag identifying the type of data to follow, 8 bits of data “representing the information identified by the tag,

UNITED STATES DISTRICT COURT
CENTRAL DISTRICT OF CALIFORNIA

CIVIL MINUTES – GENERAL

Case No. LA CV14-02454 JAK (JEMx) -- AND RELATED CASES

Date April 17, 2015

Title Signal IP v. American Honda Motor Co., Inc. -- AND RELATED CASES

e.g., the distance between the driver and the steering column,” a parity bit, and an end of message symbol comprising a single pulse. *Id.* at 4:49-60. The specification supports the agreed construction that the message is a collection of bits sent together in a message protocol.

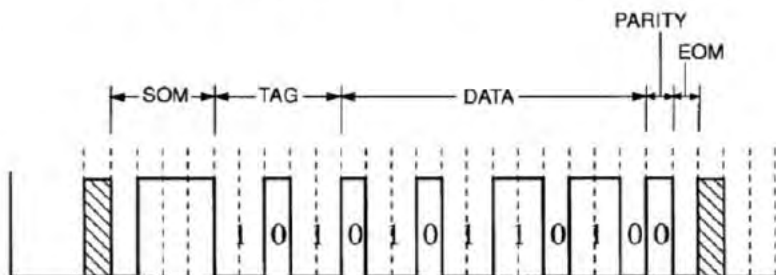

FIG - 5

The dispute is whether these bits “define the information transferred” on the message protocol. The only basis BMW provides for inserting this language is that the patent discloses sending bits for the high rate and low rate messages together in a combined protocol. *Jt. Br.*, Dkt. 53 at 221 (citing '775 Patent at 3:42-51). This is not a sufficient basis for importing the limitation proposed by BMW into the claim.

c. *The Prosecution History and the Extrinsic Evidence*

The prosecution history and the extrinsic evidence do not bear on this question.

d. *Conclusion*

Because “message” is a well-known term used in the usual sense in the '775 Patent, and the proposed constructions simply repeat the word “message” in a way that is not helpful, this term does not require construction.

Term No. 36: “Complete Message” / “Fragment of a Complete Message” (Claim 6)

Plaintiff's Proposal	Defendant's Proposal	Court's Construction
<p>Not indefinite.</p> <p>Plain and ordinary meaning.</p>	<p><u>VW/Bentley</u>: Indefinite</p>	<p>Not indefinite.</p> <p>Construction not required.</p>

VW/Bentley argue that the term is indefinite because the claim language fails to inform a skilled artisan of the bounds of the terms, and the terms are not defined in the specification. *Jt. Br.*, Dkt. 53 at 223. Plaintiff responds that the meanings of the terms are clear -- “the term ‘complete’ message simply means a complete collection of bits that are sent together in a message protocol,” while “a ‘fragment’ of

UNITED STATES DISTRICT COURT
CENTRAL DISTRICT OF CALIFORNIA

CIVIL MINUTES – GENERAL

Case No. LA CV14-02454 JAK (JEMx) -- AND RELATED CASES

Date April 17, 2015

Title Signal IP v. American Honda Motor Co., Inc. -- AND RELATED CASES

a complete message simply means a fragment of a complete collection of bits that are sent together in a message protocol.” *Id.* at 225 (emphasis omitted).

a. *The Language of the Claim*

In claim 6, the first type of data is provided “at a first message rate sufficient to form a complete message within the devoted portion of each message rate interval.” The second type of data is provided “at a second message rate sufficient to form only a fragment of a complete message in the remaining portion of each message rate interval, thereby requiring a plurality of consecutive message rate intervals to form a complete message of the second type of data.” ‘775 Patent at 6:34-42.

b. *The Specification*

Figure 2 shows the HFTI and LFTI message periods, which are reproduced below.

FIG - 2

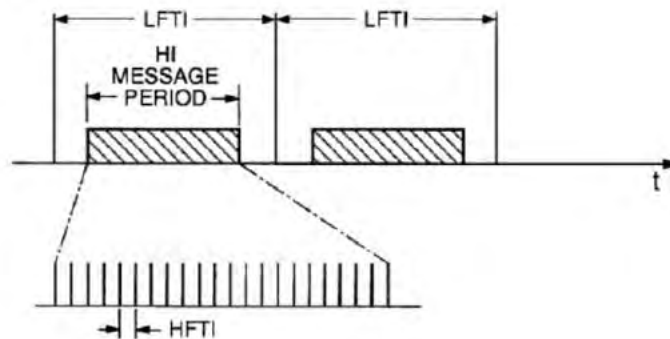

The “period reserved to the high rate message . . . is somewhat shorter than the LFTI.” *Id.* at 3:55-56. This period “consists of many HFTI intervals affording sufficient bandwidth to contain at least one complete occupant position message.” *Id.* at 3:52-60. “The ratio of the LFTI to the HFTI must be great enough to allow at [least] one complete high rate message to be contained within a single LFTI and leave sufficient time remaining within the LFTI that its state can be determined without ambiguity.” *Id.* at 3:47-51.

The complete low rate message includes the information in the following table:

UNITED STATES DISTRICT COURT
CENTRAL DISTRICT OF CALIFORNIA

CIVIL MINUTES – GENERAL

Case No. LA CV14-02454 JAK (JEMx) -- AND RELATED CASES

Date April 17, 2015

Title Signal IP v. American Honda Motor Co., Inc. -- AND RELATED CASES

CONDITION	LOW PULSE WIDTH	HIGH PULSE WIDTH
Occupant Present	1	1
Occupant Not Present	2	2
Infant Seat Facing Rearward	1	2
Infant Seat Facing Forward	2	1

Id. at 4:31-44. “Thus the low rate message is completed in two to four LFTIs or 100 ms to 200 ms.” *Id.* “The high rate message is more complex,” and includes a start of message symbol 1 HFTI wide, followed by a high pulse 3 HFTI wide, a 3 bit tag, 8 bits of data, a parity bit, and an end of message symbol 1 HFTI wide. *Id.* at 4:48-60. “A maximum of 54 HFTIs or 27 ms is required for the complete message if the data bits were all ones, and less time is required when the message includes zeros.” *Id.* at 4:61-63.

Figures 5-7, which are reproduced below, portray all the information required in a complete high rate message (Fig. 5), and how several high rate messages fit within a single low rate message (Fig. 7). “The low and high rate protocols may be used separately or simultaneously.” *Id.* at 4:48-5:9.

UNITED STATES DISTRICT COURT
CENTRAL DISTRICT OF CALIFORNIA

CIVIL MINUTES – GENERAL

Case No. LA CV14-02454 JAK (JEMx) -- AND RELATED CASES

Date April 17, 2015

Title Signal IP v. American Honda Motor Co., Inc. -- AND RELATED CASES

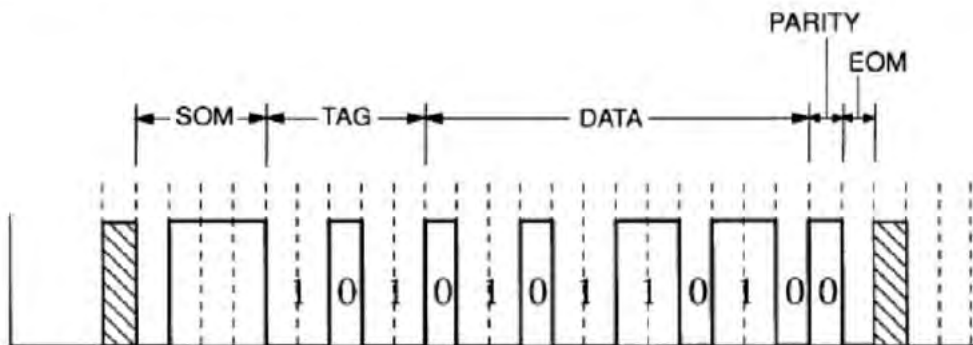

FIG - 5

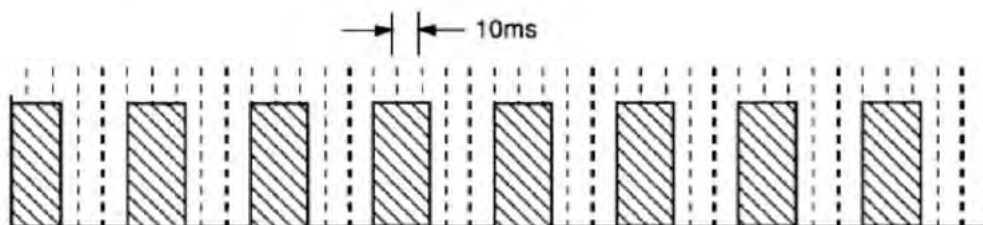

FIG - 6

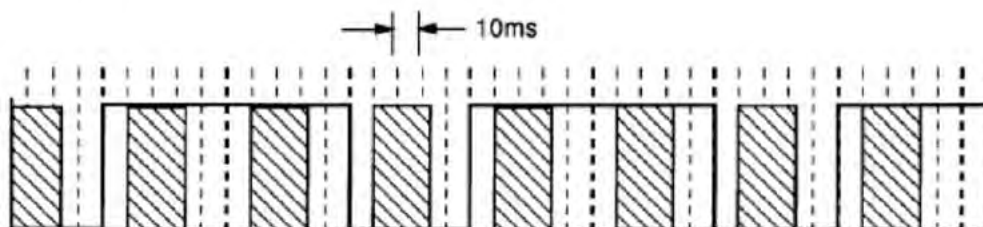

FIG - 7

According to Plaintiff, the specification clearly distinguishes a complete message from an incomplete message. *Jt. Br.*, Dkt. 53 at 225-26. Specifically, a complete message is one that includes all the necessary information. *Id.* VW/Bentley argue that it is not clear from the patent whether “a message of some unknown ‘first’ or ‘second’ types of data would be deemed ‘complete.’” *Id.* at 224.

Ultimately, a message can be complete if it contains all the required information, whether in the form of a high rate message, low rate message, or some other form.

UNITED STATES DISTRICT COURT
CENTRAL DISTRICT OF CALIFORNIA

CIVIL MINUTES – GENERAL

Case No. LA CV14-02454 JAK (JEMx) -- AND RELATED CASES

Date April 17, 2015

Title Signal IP v. American Honda Motor Co., Inc. -- AND RELATED CASES

c. The Prosecution History

VW/Bentley make essentially the same argument about the prosecution history as it did in term no. 34, which was addressed above. Once again, this position is not convincing.

d. The Extrinsic Evidence

The extrinsic evidence does not bear on this question.

e. Conclusion

Because the term is reasonably certain in the context of the specification, it is not indefinite. The parties have not demonstrated that any construction is required or would be useful.

IV. CONCLUSION

The foregoing constructions are adopted.