



US008773356B2

(12) **United States Patent**
Martin et al.

(10) **Patent No.:** **US 8,773,356 B2**

(45) **Date of Patent:** ***Jul. 8, 2014**

(54) **METHOD AND APPARATUS FOR PROVIDING TACTILE SENSATIONS**

(58) **Field of Classification Search**
USPC 345/163, 167-169, 173
See application file for complete search history.

(75) Inventors: **Kenneth M. Martin**, Los Gatos, CA (US); **Steven P. Vassallo**, Redwood City, CA (US); **Alex S. Goldenberg**, San Francisco, CA (US); **Alexander Jasso**, San Jose, CA (US); **Kollin M. Tierling**, Milpitas, CA (US)

(56) **References Cited**

U.S. PATENT DOCUMENTS

2,972,140 A 2/1961 Hirsch
3,157,853 A 11/1964 Hirsch
3,220,121 A 11/1965 Cutler

(Continued)

FOREIGN PATENT DOCUMENTS

EP 0349086 1/1990
EP 0817110 1/1998

(Continued)

OTHER PUBLICATIONS

Adelstein, "A Virtual Environment System for the Study of Human Arm Tremor," Ph.D. Dissertation, Dept. of Mechanical Engineering, MIT, Jun. 1989.

(Continued)

Primary Examiner — Ricardo L Osorio

(74) *Attorney, Agent, or Firm* — Kilpatrick Townsend & Stockton LLP

(57) **ABSTRACT**

Systems and methods for providing tactile sensations are disclosed. For example, one disclosed method includes the steps of outputting a display signal configured to display a graphical object on a touch-sensitive input device; receiving a sensor signal from the touch-sensitive input device, the sensor signal indicating an object contacting the touch-sensitive input device; determining an interaction between the object contacting the touch-sensitive input device and the graphical object; and generating an actuator signal based at least in part on the interaction.

(73) Assignee: **Immersion Corporation**, San Jose, CA (US)

(*) Notice: Subject to any disclaimer, the term of this patent is extended or adjusted under 35 U.S.C. 154(b) by 0 days.

This patent is subject to a terminal disclaimer.

(21) Appl. No.: **13/362,113**

(22) Filed: **Jan. 31, 2012**

(65) **Prior Publication Data**

US 2013/0027324 A1 Jan. 31, 2013

Related U.S. Application Data

(63) Continuation of application No. 12/894,489, filed on Sep. 30, 2010, now Pat. No. 8,159,461, which is a continuation of application No. 11/693,117, filed on Mar. 29, 2007, now Pat. No. 7,808,488, which is a continuation of application No. 10/285,450, filed on Nov. 1, 2002, now Pat. No. 7,336,260.

(60) Provisional application No. 60/335,493, filed on Nov. 1, 2001, provisional application No. 60/399,883, filed on Jul. 31, 2002.

(51) **Int. Cl.**
G06F 3/033 (2013.01)
G09G 5/00 (2006.01)

(52) **U.S. Cl.**
USPC **345/163; 345/167**

26 Claims, 11 Drawing Sheets

INPUT DEVICE	INPUT SIGNAL	POSITION DATA	PRESSURE DATA	FUNCTION	TACTILE SENSATION
1	--	Location 1	< Pressure 1	Search	Sensation 1
	Input 1	Location 1	Pressure 1 <=	Select	Sensation 2
2	--	Position 1	--	On	Sensation 3
	--	Position 2	--	Off	Sensation 4
3	Input 2A	--	Pressure 1	9	Sensation 5
	Input 2B	--	Pressure 2	W	Sensation 6
	Input 2C	--	Pressure 3	X	Sensation 7
	Input 2D	--	Pressure 4	Y	Sensation 8
	Input 2E	--	Pressure 5	Z	Sensation 9
4	Input 3	--	Pressure 1	Menu 1	Sensation 10
		--	Pressure 2	Menu 2	Sensation 11
		--	Pressure 3	Menu 3	Sensation 12
5	---	--	Pressure 1	2	Sensation 13
		--	Pressure 2	A	Sensation 14
		--	Pressure 3	B	Sensation 15
		--	Pressure 4	C	Sensation 16
6	Input 4	Position 1	Pressure 1	Function 1	Sensation 17
	Input 5	Position 2	Pressure 2	Function 2	Sensation 18
	Input 6	Position 3	Pressure 3	Function 3	Sensation 19
7	Input 7	Location 1	Pressure 1	Function 1	Sensation 20
	Input 8	Location 2	Pressure 2	Function 2	Sensation 21
--	AMBIGUOUS	--	--	--	Sensation 22

(56)

References Cited

FOREIGN PATENT DOCUMENTS

KR	2001-0028369	4/2001
WO	95/20787	8/1995
WO	97/18546	5/1997
WO	99/49443	9/1999
WO	01/54109	7/2001
WO	02/27645	4/2002
WO	02/31807	4/2002
WO	02/019110	11/2002

OTHER PUBLICATIONS

Adelstein, "Design and Implementation of a Force Reflecting Manipulandum for Manual Control research," DSC-vol. 42, Advances in Robotics, Edited by H. Kazerooni, pp. 1-12, 1992.

Aukstakalnis et al., "Silicon Mirage: The Art and Science of Virtual Reality," ISBN 0-938151-82-7, pp. 129-180, 1992.

Baigrie, "Electric Control Loading—A Low Cost, High Performance Alternative," Proceedings, pp. 247-254, Nov. 6-8, 1990.

Bejczy, "Sensors, Controls, and Man-Machine Interface for Advanced Teleoperation," Science, vol. 208, No. 4450, pp. 1327-1335, 1980.

Bejczy, "Generalization of Bilateral Force-Reflecting Control of Manipulators," Proceedings of Fourth CISM-IFTOMM, Sep. 8-12, 1981.

Bejczy, et al., "Universal Computer Control System (UCCS) for Space Telerobots," CH2413-3/87/0000/0318501.00 1987 IEEE, 1987.

Bejczy et al., "A Laboratory Breadboard System for Dual-Arm Teleoperation," SOAR '89 Workshop, JSC, Houston, TX, Jul. 25-27, 1989.

Bliss, "Optical-to-Tactile Image Conversion for the Blind," IEEE Transactions on Man-Machine Systems, vol. MMS-11, No. 1, Mar. 1970.

Brooks et al., "Hand Controllers for Teleoperation—A State-of-the-Art Technology Survey and Evaluation," JPL Publication 85-11; NASA-CR-175890; N85-28559, pp. 1-84, Mar. 1, 1985.

Burdea et al., "Distributed Virtual Force Feedback, Lecture Notes for Workshop on Force Display in Virtual Environments and its Application to Robotic Teleoperation," 1993 IEEE International Conference on Robotics and Automation, pp. 25-44, May 2, 1993.

Cadler, "Design of a Force-Feedback Touch-Introducing Actuator for Teleoperator Robot Control," Bachelor of Science Thesis, MIT, Jun. 23, 1983.

Caldwell et al., "Enhanced Tactile Feedback (Tele-Traction) Using a Multi-Functional Sensory System," 1050-4729/93, pp. 955-960, 1993.

Eberhardt et al., "OMAR—A Haptic display for speech perception by deaf and def-blind individuals," IEEE Virtual Reality Annual International Symposium, Seattle, WA, Sep. 18-22, 1993.

Eberhardt et al., "Inducing Dynamic Haptic Perception by The Hand: System Description and Some Results," DSC-vol. 55-1, Dynamic Systems and Control: vol. 1, ASME 1994.

Fukumoto, "Active Click: Tactile Feedback for Touch Panels," ACM CHI2001 Extended Abstracts, pp. 121-122, Apr. 2001.

Gobel et al., "Tactile Feedback Applied to Computer Mice," International Journal of Human-Computer Interaction, vol. 7, No. 1, pp. 1-24, 1995.

Gotow et al., "Controlled Impedance Test Apparatus for Studying Human Interpretation of Kinesthetic Feedback," WA11-11:00, pp. 332-337.

Howe, "A Force-Reflecting Teleoperated Hand System for the Study of Tactile Sensing in Precision Manipulation," Proceedings of the 1992 IEEE International Conference on Robotics and Automation, Nice, France, May 1992.

IBM Technical Disclosure Bulletin, "Mouse Ball-Actuating Device With Force and Tactile Feedback," vol. 32, No. 9B, Feb. 1990.

Iwata, "Pen-based Haptic Virtual Environment," 0-7803-1363-1/93 IEEE, pp. 287-292, 1993.

Jacobsen et al., "High Performance, Dextrous Telerobotic Manipulator With Force Reflection," Intervention/ROV '91 Conference & Exposition, Hollywood, Florida, May 21-23, 1991.

Johnson, "Shape-Memory Alloy Tactile Feedback Actuator," Armstrong Aerospace Medical Research Laboratory, AAMRL-TR-90-039, Aug. 1990.

Jones et al., "A perceptual analysis of stiffness," ISSN 0014-4819 Springer International (Springer-Verlag); Experimental Brain Research, vol. 79, No. 1, pp. 150-156, 1990.

Kaczmarek et al., "Tactile Displays," Virtual Environment Technologies.

Kontarinis et al., "Display of High-Frequency Tactile Information to Teleoperators," Telemanipulator Technology and Space Telerobotics, Won S. Kim, Editor, Proc. SPIE vol. 2057, pp. 40-50, Sep. 7-9, 1993.

Kontarinis et al., "Tactile Display of Vibratory Information in Teleoperation and Virtual Environments," Presence, 4(4):387-402, 1995.

Lake, "Cyberman from Logitech," GameBytes, 1994.

Marcus, "Touch Feedback in Surgery," Proceedings of Virtual Reality and Medicine The Cutting Edge, Sep. 8-11, 1994.

McAfee, "Teleoperator Subsystem/Telerobot Demonstrator: Force Reflecting Hand Controller Equipment Manual," JPL D-5172, pp. 1-50, A1-A36, B1-B5, C1-C36, Jan. 1988.

Minsky, "Computational Haptics: The Sandpaper System for Synthesizing Textue for a Force-Feedback Display," Ph.D. Dissertation, MIT, Jun. 1995.

Ouh-Young, "Force Display in Molecular Docking," Order No. 9034744, p. 1-369, 1990.

Ouh-Young, "A Low-Cost Force Feedback Joystick and Its Use in PC Video Games," IEEE Transactions on Consumer Electronics, vol. 41, No. 3, Aug. 1995.

Ouhyoung et al., "The Development of a Low-Cost Force Feedback Joystick and Its Use in the Virtual Reality Environment," Proceedings of the Third Pacific Conference on Computer Graphics and Applications, Pacific Graphics '95, Seoul, Korea, Aug. 21-24, 1995.

Patrick et al., "Design and Testing of a Non-reactive, Fingertip, Tactile Display for Interaction with Remote Environments," Cooperative Intelligent Robotics in Space, Rui J. deFigueiredo et al., Editor, Proc. SPIE vol. 1387, pp. 215-222, 1990.

Pimentel et al., "Virtual Reality: through the new looking glass," 2nd Edition; McGraw-Hill, ISBN 0-07-050167-X, pp. 41-202, 1994.

Rabinowitz et al., "Multidimensional tactile displays: Identification of vibratory intensity, frequency, and contactor area," Journal of the Acoustical Society of America, vol. 82, No. 4, Oct. 1987.

Russo, "The Design and Implementation of a Three Degree of Freedom Force Output Joystick," MIT Libraries Archives Aug. 14, 1990, pp. 1-131, May 1990.

Russo, "Controlling Dissipative Magnetic Particle Brakes in Force Reflective Devices," DSC-vol. 42, Advances in Robotics, pp. 63-70, ASME 1992.

Scannell, "Taking a Joystick Ride", Computer Currents, Nov. 1994, Boston Edition, vol. 9 No. 11.

Shimoga, "Finger Force and Touch Feedback Issues in Dexterous Telemanipulation," Proceedings of Fourth Annual Conference on Intelligent Robotic Systems for Space Exploration, Rensselaer Polytechnic Institute, Sep. 30-Oct. 1, 1992.

SMK Corporation, "Multi-Functional Touch Panel, Force-Feedback Type, Developed: A Touch Panel Providing a Clicking Feeling," http://www.smk.co.jp/whatsnew_e/628csc_e.html, Sep. 30, 2002.

SMK Corporation, "Force Feedback Type Optical Touch Panel Developed," SMK Corporation Website, Oct. 30, 2002.

Snow et al., "Model-X Force-Reflecting-Hand-Controller," NT Control No. MPO-17851; JPL Case No. 5348, pp. 1-4, Jun. 15, 1989.

Stanley et al., "Computer Simulation of Interacting Dynamic Mechanical Systems Using Distributed Memory Parallel Processors," DSV-vol. 42, Advances in Robotics, pp. 55-61, ASME 1992.

Tadros, "Control System Design for a Three Degree of Freedom Virtual Environment Simulator Using Motor/Brake Pair Actuators,"

(56)

References Cited

OTHER PUBLICATIONS

Terry et al., "Tactile Feedback in a Computer Mouse," Proceedings of Fourteenth Annual Northeast Bioengineering Conference, University of New Hampshire, Mar. 10-11, 1988.

Wakiwaka, et al., "Influence of Mover Support Structure on Linear Oscillatory Actuator for Cellular Phones," The Third International Symposium on Linear Drives for Industry Applications, 2001, p. 260-263, Nagano, Japan.

Wiker, "Teletouch Display Development: Phase I Report," Technical Report 1230, Naval Ocean Systems Center, San Diego, Apr. 17, 1989.

Notification of First Office Action mailed Sep. 5, 2007 for corresponding Chinese Application 02821854.X.

Notice of Reasons for Rejection for Jan. 29, 2008 mailed Feb. 20, 2008 for corresponding Japanese Patent Application No. 2003-540973.

Notice of Reasons for Rejection of Sep. 11, 2007 mailed Sep. 11, 2007 for corresponding Japanese Patent Application No. 2003-540973.

United States Patent and Trademark Office, Office Action mailed Dec. 23, 2005 for corresponding U.S. Appl. No. 10/285,450.

United States Patent and Trademark Office, Office Action mailed May 18, 2006 for corresponding U.S. Appl. No. 10/285,450.

United States Patent and Trademark Office, Office Action mailed Nov. 15, 2006 for corresponding U.S. Appl. No. 10/285,450.

United States Patent and Trademark Office, Office Action mailed Jun. 1, 2007 for corresponding U.S. Appl. No. 10/285,450.

European Supplemental Search Report mailed Jul. 1, 2008 for corresponding European Patent Application No. 02773960.6.

Notice of Preliminary Rejection mailed Mar. 28, 2009 for corresponding Korean Patent Application No. 10-2004-7006627.

Office Action mailed Nov. 25, 2009 for corresponding Korean Patent Application No. 10-2009-7017838.

Office Action mailed May 10, 2010 for corresponding Korean Patent Application No. 10-2009-7017838.

Office Action mailed Nov. 25, 2009 for corresponding Korean Patent Application No. 10-2004-7006627.

Office Action mailed Jul. 2, 2010 for corresponding Korean Patent Application No. 10-2009-7006555.

Office Action mailed Jun. 19, 2009 for corresponding Chinese Application No. 200810008845.X.

Office Action mailed Nov. 1, 2010 for corresponding Chinese Application No. 200810008845.X.

Office Action mailed Nov. 23, 2010 for corresponding Chinese Application No. 02821854.X.

Office Action mailed Mar. 5, 2009 for corresponding U.S. Appl. No. 11/693,117.

Office Action mailed Jun. 24, 2009 for corresponding U.S. Appl. No. 11/693,117.

Office Action mailed Dec. 29, 2009 for corresponding U.S. Appl. No. 11/693,117.

Office Action mailed Jul. 7, 2011 for corresponding Chinese Application No. 200810008815.X.

Office Action mailed Dec. 5, 2012 for corresponding Korean Patent Application No. 10-2011-7025866.

Office Action mailed Aug. 23, 2011 for corresponding Korean Patent Application No. 10-2010-7006555.

Office Action mailed Oct. 26, 2010 for corresponding Korean Patent Application No. 10-2009-7017838.

Office Action mailed May 18, 2010 for corresponding Korean Patent Application No. 10-2004-7006627.

Communication pursuant to Article 94(3) EPC mailed May 10, 2012 for corresponding European Application No. 08007837.1.

Notification of Reexamination mailed Mar. 9, 2012 for corresponding Chinese Application 02821854.X.

United States Patent and Trademark Office, Office Action mailed Mar. 2, 2011 for corresponding U.S. Appl. No. 12/894,489.

United States Patent and Trademark Office, Office Action mailed Aug. 17, 2011 for corresponding U.S. Appl. No. 12/894,489.

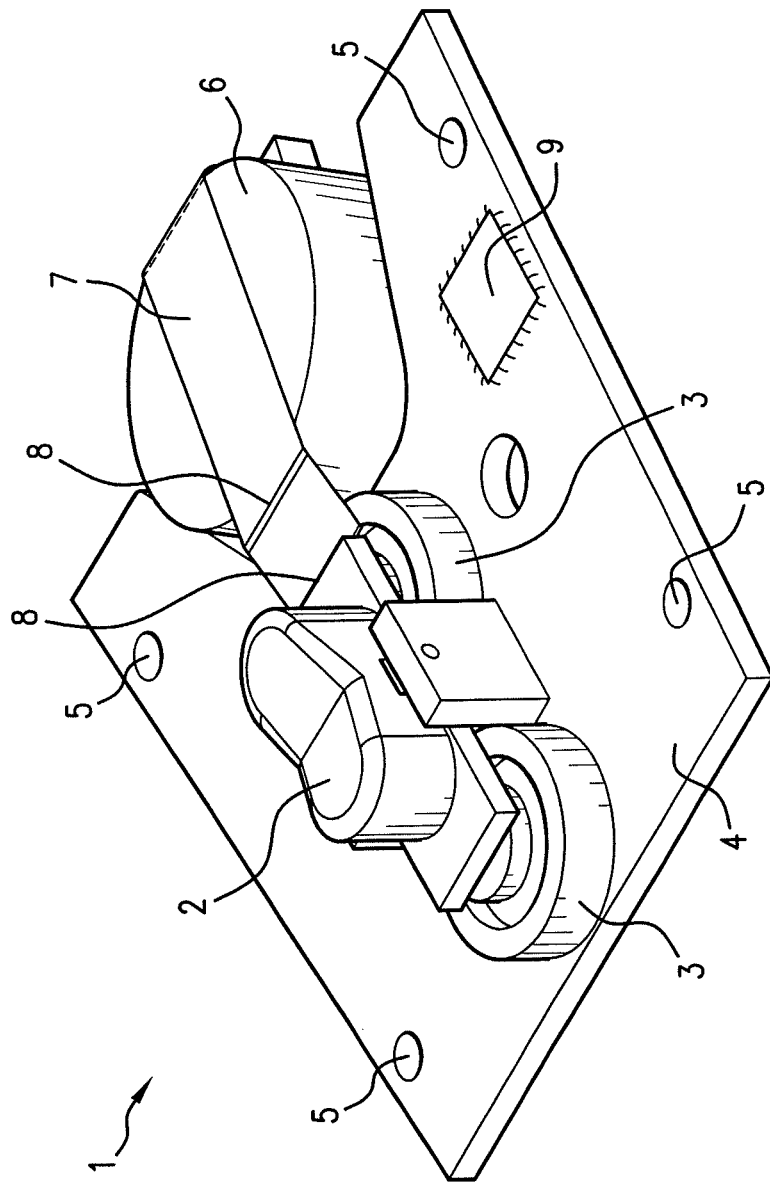

FIG. 1

Explore Litigation Insights

Docket Alarm provides insights to develop a more informed litigation strategy and the peace of mind of knowing you're on top of things.

Real-Time Litigation Alerts



Keep your litigation team up-to-date with **real-time alerts** and advanced team management tools built for the enterprise, all while greatly reducing PACER spend.

Our comprehensive service means we can handle Federal, State, and Administrative courts across the country.

Advanced Docket Research



With over 230 million records, Docket Alarm's cloud-native docket research platform finds what other services can't. Coverage includes Federal, State, plus PTAB, TTAB, ITC and NLRB decisions, all in one place.

Identify arguments that have been successful in the past with full text, pinpoint searching. Link to case law cited within any court document via Fastcase.

Analytics At Your Fingertips



Learn what happened the last time a particular judge, opposing counsel or company faced cases similar to yours.

Advanced out-of-the-box PTAB and TTAB analytics are always at your fingertips.

API

Docket Alarm offers a powerful API (application programming interface) to developers that want to integrate case filings into their apps.

LAW FIRMS

Build custom dashboards for your attorneys and clients with live data direct from the court.

Automate many repetitive legal tasks like conflict checks, document management, and marketing.

FINANCIAL INSTITUTIONS

Litigation and bankruptcy checks for companies and debtors.

E-DISCOVERY AND LEGAL VENDORS

Sync your system to PACER to automate legal marketing.