

UNITED STATES PATENT AND TRADEMARK OFFICE

---

BEFORE THE PATENT TRIAL AND APPEAL BOARD

---

R.J. REYNOLDS VAPOR COMPANY  
Petitioner,

v.

FONTEM HOLDINGS 1 B.V.,  
Patent Owner.

---

Case IPR2016-01268  
Patent 8,365,742 B2

---

Before BRIAN J. McNAMARA, JEREMY M. PLENZLER, and  
JO-ANNE M. KOKOSKI, *Administrative Patent Judges*.

KOKOSKI, *Administrative Patent Judge*.

DECISION  
Institution of *Inter Partes* Review  
37 C.F.R. § 42.108

## I. INTRODUCTION

R.J. Reynolds Vapor Company (“Petitioner”) filed a Petition (“Pet.”) to institute an *inter partes* review of claims 2 and 3 of U.S. Patent No. 8,365,742 B2 (“the ’742 patent,” Ex. 1001). Paper 2. Fontem Holdings 1 B.V. (“Patent Owner”) filed a Preliminary Response (“Prelim. Resp.”). Paper 8. We have jurisdiction under 35 U.S.C. § 314.

Upon consideration of the Petition and Preliminary Response, we determine that Petitioner has established a reasonable likelihood of prevailing with respect to the unpatentability of claims 2 and 3 of the ’742 patent. Accordingly, we institute an *inter partes* review of those claims.

### A. *Related Proceedings*

The parties indicate that the ’742 patent is asserted in numerous cases pending in the Central District of California, including *Fontem Ventures B.V. v. R.J. Reynolds Vapor Company*, Case No. 2:16-cv-02286. Pet. 2–3; Paper 4, 1–5; Paper 6, 2. The ’742 patent was previously the subject of IPR2015-00859 (“the 859 IPR,” institution denied on September 9, 2015) and IPR2015-01587 (terminated on December 14, 2015 at the joint request of the parties before an institution decision was entered) (Pet. 3; Paper 4, 7), and also currently is the subject of IPR2016-01532, filed by Petitioner on August 5, 2016, and IPR2016-01303, filed by Nu Mark LLC on June 28, 2016 (Paper 4, 7; Paper 7, 1).

### B. *The ’742 Patent (Ex. 1001)*

The ’742 patent, titled “Electronic Cigarette,” is directed to an aerosol electronic cigarette having a battery assembly, an atomizer assembly, a cigarette bottle assembly, and a hollow, integrally-formed shell. Ex. 1001, Abstract. According to the ’742 patent, prior art devices had various

disadvantages, including low atomizing efficiency, being structurally complicated, and not providing ideal aerosol effects. *Id.* at 1:21–24.

Figure 1 of the '742 patent is reproduced below:

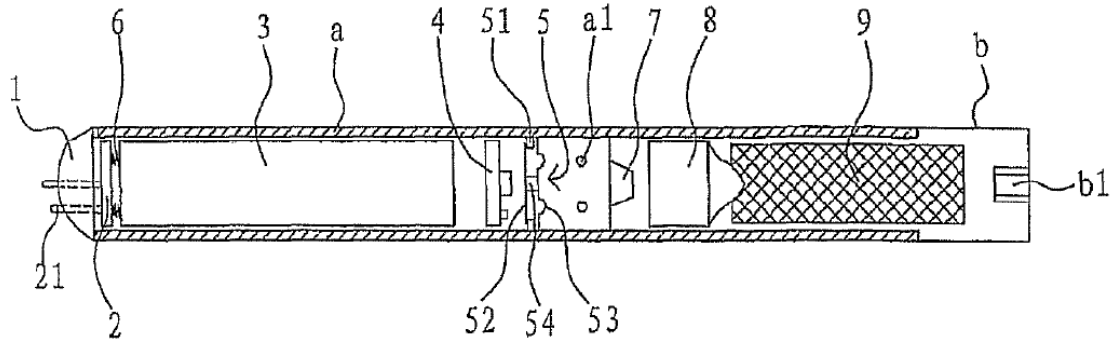

Figure 1

Figure 1 is a side section view of an electronic cigarette. *Id.* at 1:45. Hollow, integrally-formed shell “a” includes a battery assembly, atomizer assembly, and cigarette bottle assembly. *Id.* at 2:30–33. The battery assembly connects to the atomizer assembly in shell “a,” and the detachable cigarette body assembly (which fits with the atomizer assembly) is located in one end of shell “a.” *Id.* at 2:33–37. Shell “a” also includes through-air-inlets a1. *Id.* at 2:37–38. The battery assembly includes operating indicator 1, battery 3, electronic circuit board 4, and airflow sensor 5. *Id.* at 2:39–45. The atomizer assembly is atomizer 8, which includes a porous component and a heating rod. *Id.* at 3:6–8. The cigarette bottle assembly includes hollow cigarette shell holder “b,” and perforated component for liquid storage 9. *Id.* at 3:49–51. Air channel b1 is located in the center on the

surface of one end of cigarette shell holder “b,” and extends inward. *Id.* at 3:59–62.

Figures 5, 6, and 7 of the '742 patent are reproduced below:

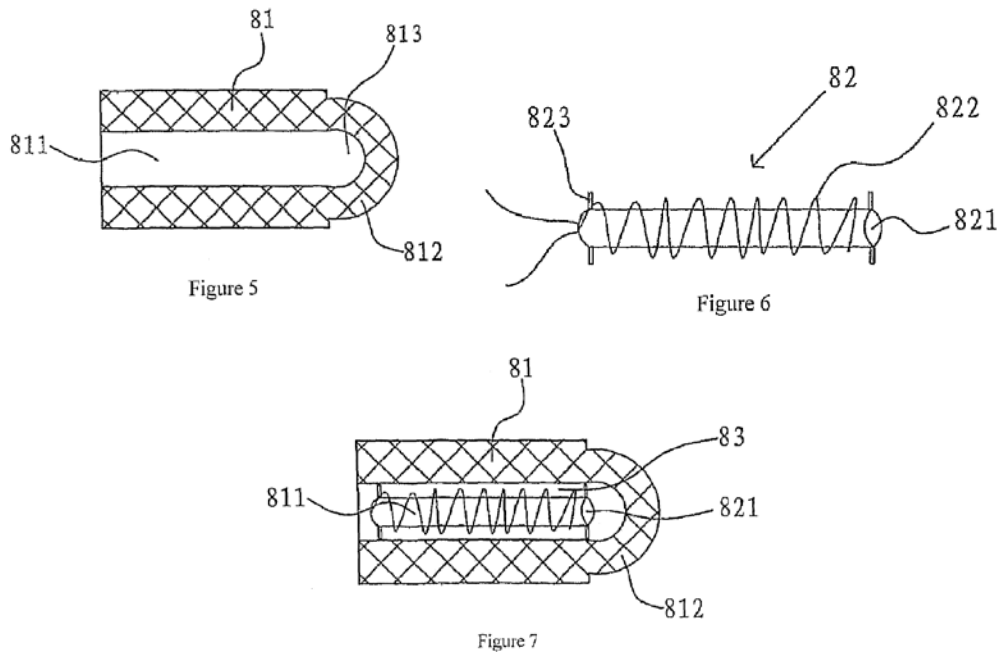

Figure 5 is a side-section view of the porous component of atomizer 8, Figure 6 is a diagram of the structure of a heating rod in atomizer 8, and Figure 7 is a side-section view of atomizer 8. *Id.* at 1:53–59. Atomizer 8 includes porous component 81 and heating rod 82. *Id.* at 3:6–8. Heating rod 82 includes heating wire 822 wound on the wall of cylinder 821. *Id.* at 3:28–30. Porous component 81 contains run-through atomizing chamber 811. *Id.* at 3:8–9. Heating rod 82 enters run-through atomizing chamber 811, and the space between heating rod 82 and the interior wall of run-through atomizing chamber 811 creates negative pressure cavity 83. *Id.* at 3:11–15. One end of porous component 81 fits with the cigarette bottle

assembly, with protuberance 812 at the other end connecting to atomizing chamber 811 with run-through hole 813. *Id.* at 3:16–19.

*C. Challenged Claims*

Petitioner challenges claims 2 and 3 of the '742 patent, which are reproduced below.

2. An electronic cigarette, comprising:

a battery assembly and an atomizer assembly within a housing with the battery assembly electrically connected to the atomizer assembly;

a liquid storage component in the housing;

with the housing having one or more through-air-inlets;

the atomizer assembly including a porous component supported by a frame having a run-through hole;

a heating wire wound on a part of the porous component in the path of air flowing through the run-through hole; and

the porous component substantially surrounded by the liquid storage component.

3. An electronic cigarette, comprising:

a battery assembly and an atomizer assembly within a housing with the battery assembly electrically connected to the atomizer assembly;

with the housing having one or more through-air-inlets and an outlet;

the atomizer assembly includes a frame having a run through hole, and a porous component between the frame and the outlet;

a heating wire wound on a part of the porous component which is substantially aligned with the run-through hole; and

with the porous component in contact with a liquid supply in the housing.

# Explore Litigation Insights

Docket Alarm provides insights to develop a more informed litigation strategy and the peace of mind of knowing you're on top of things.

## Real-Time Litigation Alerts



Keep your litigation team up-to-date with **real-time alerts** and advanced team management tools built for the enterprise, all while greatly reducing PACER spend.

Our comprehensive service means we can handle Federal, State, and Administrative courts across the country.

## Advanced Docket Research



With over 230 million records, Docket Alarm's cloud-native docket research platform finds what other services can't. Coverage includes Federal, State, plus PTAB, TTAB, ITC and NLRB decisions, all in one place.

Identify arguments that have been successful in the past with full text, pinpoint searching. Link to case law cited within any court document via Fastcase.

## Analytics At Your Fingertips



Learn what happened the last time a particular judge, opposing counsel or company faced cases similar to yours.

Advanced out-of-the-box PTAB and TTAB analytics are always at your fingertips.

## API

Docket Alarm offers a powerful API (application programming interface) to developers that want to integrate case filings into their apps.

## LAW FIRMS

Build custom dashboards for your attorneys and clients with live data direct from the court.

Automate many repetitive legal tasks like conflict checks, document management, and marketing.

## FINANCIAL INSTITUTIONS

Litigation and bankruptcy checks for companies and debtors.

## E-DISCOVERY AND LEGAL VENDORS

Sync your system to PACER to automate legal marketing.