

US005893752A

United States Patent [19]
Zhang et al.

[11] **Patent Number:** **5,893,752**
[45] **Date of Patent:** **Apr. 13, 1999**

- [54] **PROCESS FOR FORMING A SEMICONDUCTOR DEVICE**
- [75] Inventors: **Jiming Zhang**, Austin; **Dean J. Denning**, Del Valle, both of Tex.
- [73] Assignee: **Motorola, Inc.**, Schaumburg, Ill.
- [21] Appl. No.: **08/996,000**
- [22] Filed: **Dec. 22, 1997**
- [51] **Int. Cl.⁶** **H01L 21/00**
- [52] **U.S. Cl.** **438/687**; 438/687; 438/627; 438/628; 438/643
- [58] **Field of Search** 438/653, 627-28, 438/654, 656, 643, 644, 645, 648, 680, 681, 658, 687

[56] **References Cited**
U.S. PATENT DOCUMENTS

5,206,187	4/1993	Doan et al.	437/192
5,231,053	7/1993	Bost et al.	437/190
5,289,035	2/1994	Bost et al.	257/750
5,323,047	6/1994	Nguyen	257/384
5,391,517	2/1995	Gelatos et al.	438/643
5,420,072	5/1995	Fiordalice et al.	438/607
5,468,339	11/1995	Gupta et al.	216/67
5,614,437	3/1997	Choudhury	437/140
5,677,238	10/1997	Gn et al.	438/653
5,747,360	5/1998	Nulman	1/1

FOREIGN PATENT DOCUMENTS

0 163 830 A2	12/1985	European Pat. Off.	H01L 23/52
0 673 063 A2	9/1995	European Pat. Off.	H01L 21/768

OTHER PUBLICATIONS

- Wolf et al. Silicon Processing for the VLSI Era vol. 2, pp. 273-276, 1990, no month.
- Han Sin Lee et al., An Optimized Densification of the Filled Oxide for Quarter Micro Shallow Trench Isolation (STI), 1996 Symposium on VLSI Technology, Digest of Technical Papers, International Electron Devices Meeting, pp. 158-159 (1966).

- Torres, Advanced copper Interconnections for silicon CMOS technologies, Applied Surface Science 91 (1995) pp. 112-123.
- Wang, Barriers Against Copper Diffusion into Silicon and Drift Through Silicon Dioxide, MRS Bulletin/Aug. 1994, pp. 30-39.
- Reid et al., Evaluation of amorphous (Mo, Ta W)—Si—N diffusion barriers for <Si>/Cu metallizations, Elsevier Sequoia (1993), pp. 319-324.
- Wang et al., Diffusion barrier study on TaSi^x and TaSi_xN_y, Elsevier Sequoia (1993) pp. 169-174.
- Smolinsky et al., Material Properties of Spin-on Silicon Oxide (SOX) for Fully Recessed NMOS Field Isolation, J. Electrochem. Soc., vol. 137, No. 1, Jan. 1990, The Electrochemical Society, Inc., pp. 229-234.
- Selective Oxidation of Titanium while forming Titanium Silicide at Polysilicon and Diffusions, IBM Technical Disclosure Bulletin vol. 27 No. 10A Mar. 1985.
- Frisa et al.; U.S. appl. No. 8/804,589, filed Feb. 26, 1997.
- Frisa et al.; U.S. appl. No. 08/887,654 filed Jul. 3, 1997.

Primary Examiner—Charles Bowers
Assistant Examiner—Thanh Nguyen
Attorney, Agent, or Firm—George R. Meyer

[57] **ABSTRACT**

A semiconductor device comprises a substrate (100), first conductive film (22 and 32) over the substrate (100), and a second conductive film (54 and 64) over the first conductive film (22 and 32). The first conductive film includes a refractory metal and nitrogen. The first conductive film has a first portion (22) that lies closer to the substrate and a second portion (32) that lies further from the substrate. The nitrogen percentage for the second portion (32) is lower than the nitrogen atomic percentage for the first portion (22). The second conductive film (54 and 64) includes mostly copper. The combination of portions (22 and 32) within the first conductive film provides a good diffusion barrier (first portion) and has good adhesion (second portion) with the second conductive film (54 and 64).

22 Claims, 5 Drawing Sheets

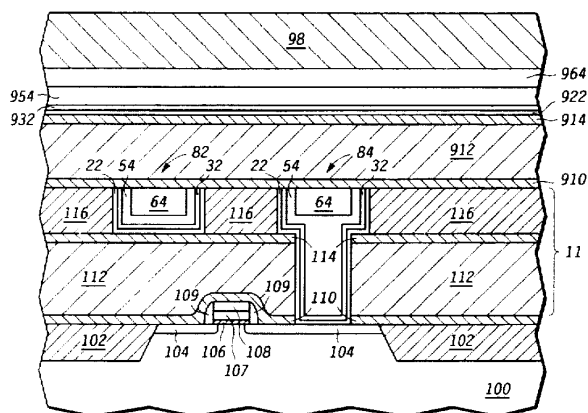

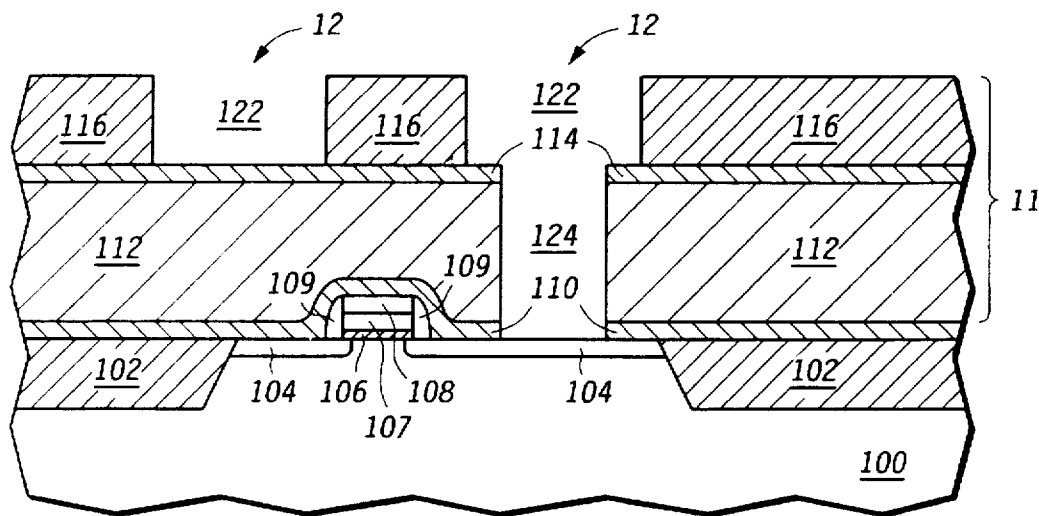

FIG. 1

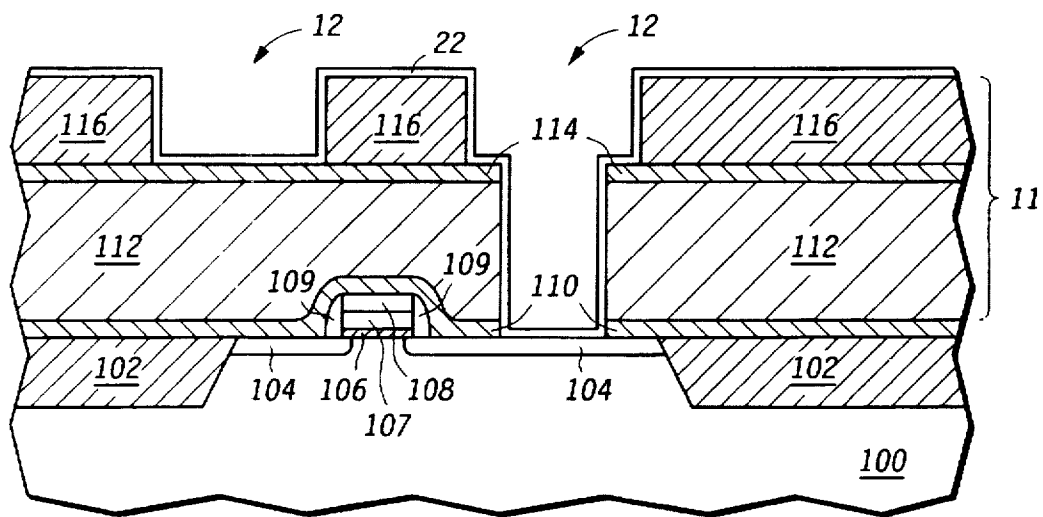

FIG. 2

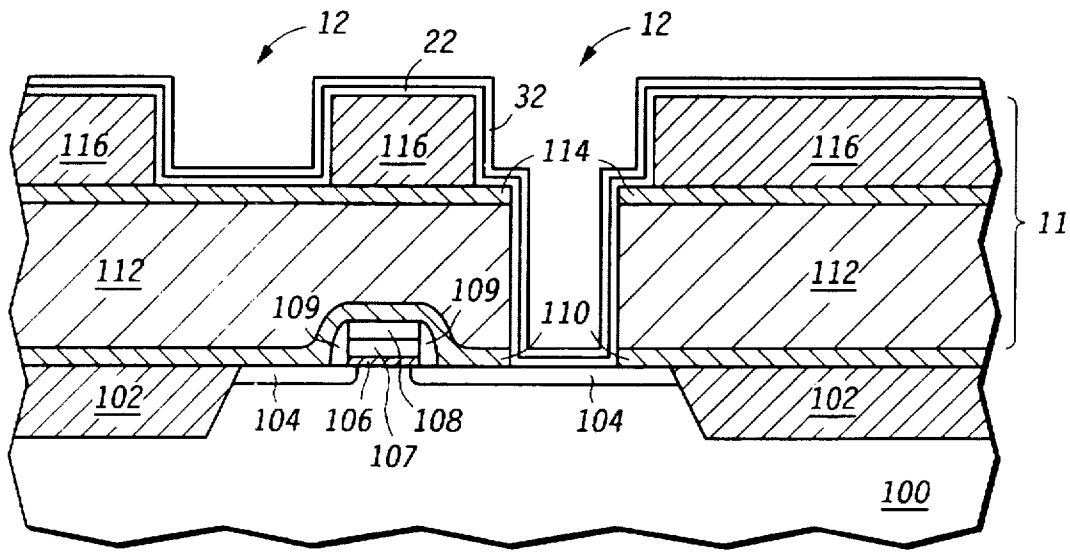

FIG. 3

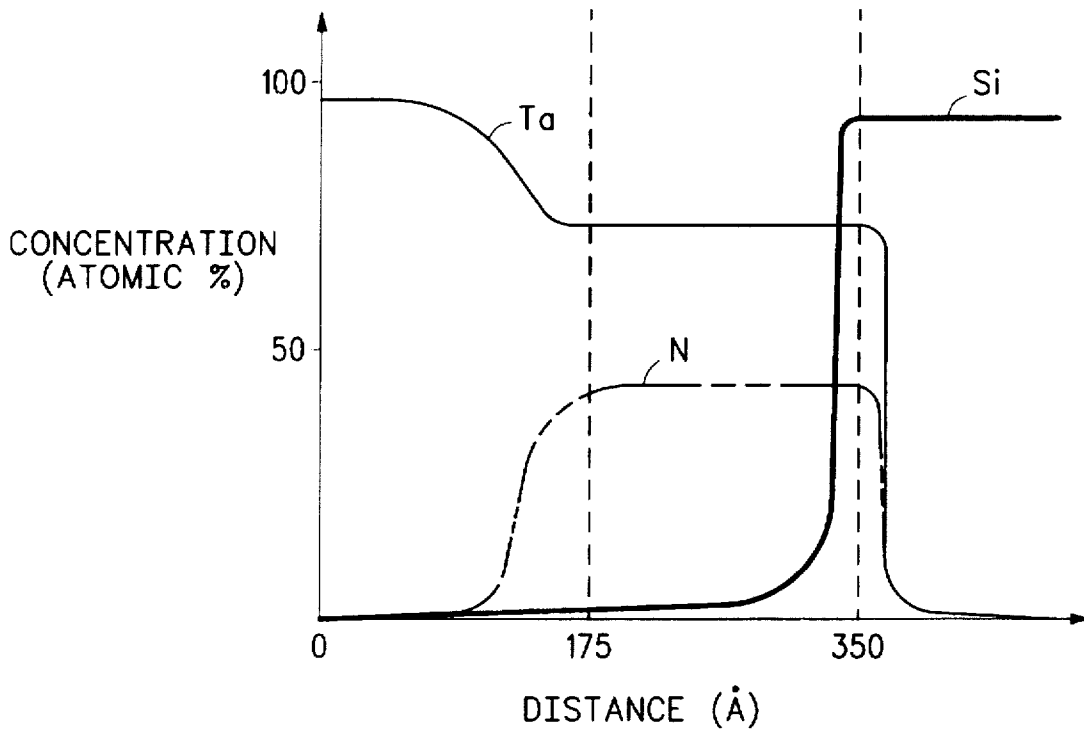

FIG. 4

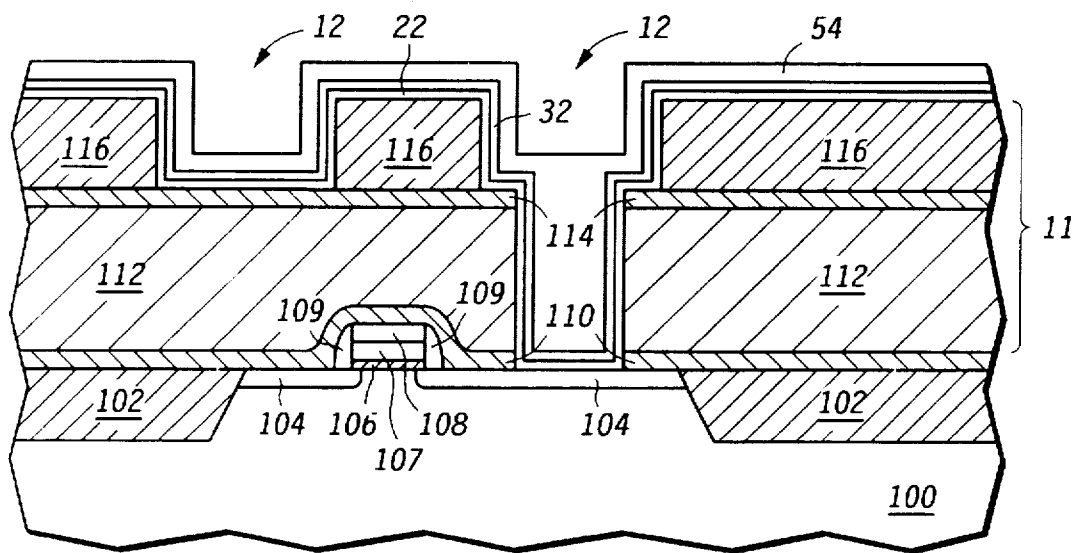

FIG. 5

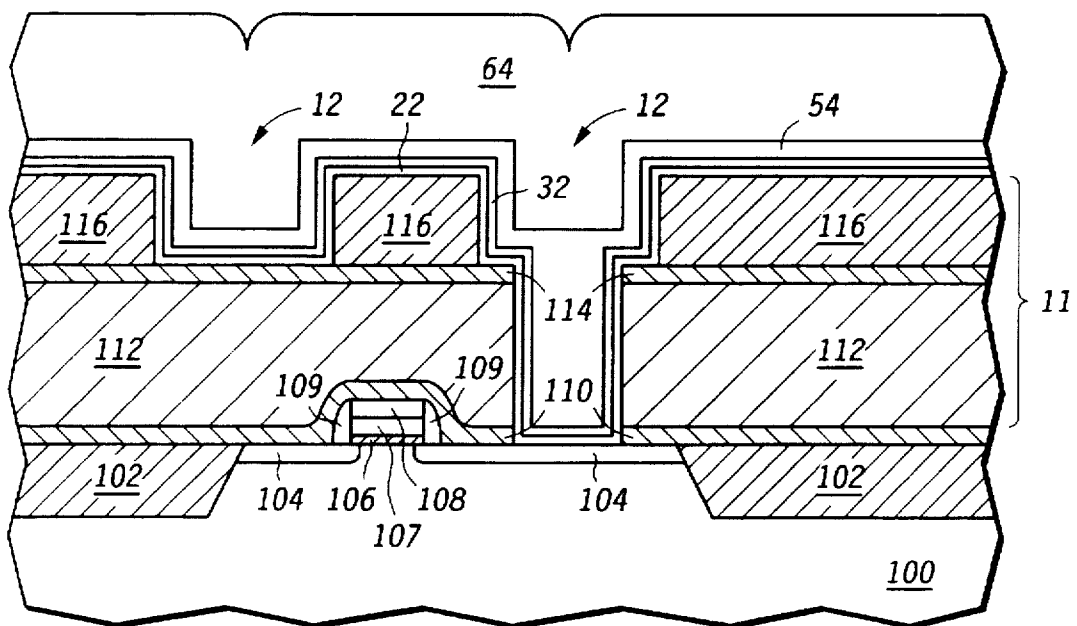

FIG. 6

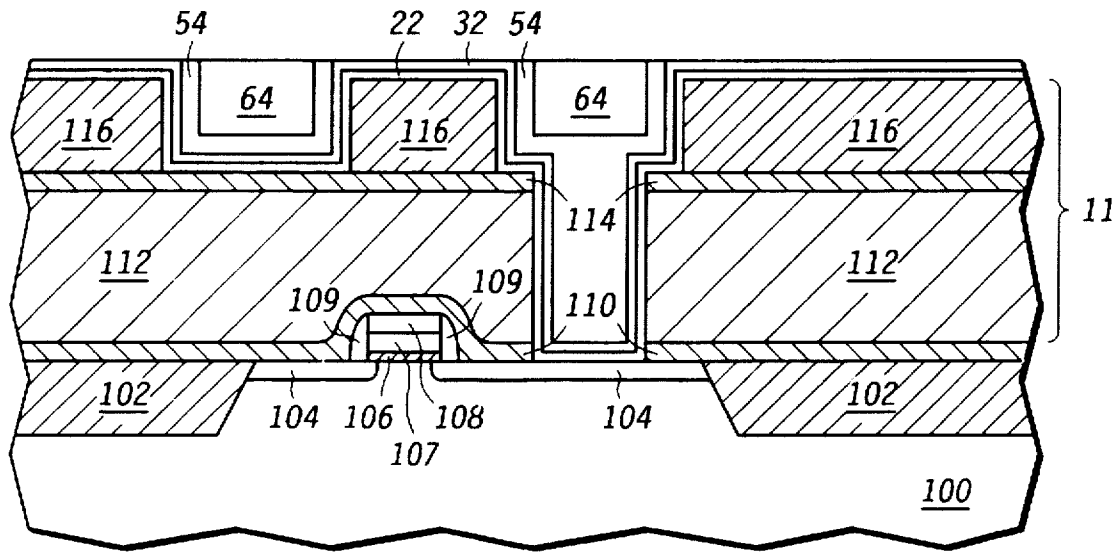

FIG. 7

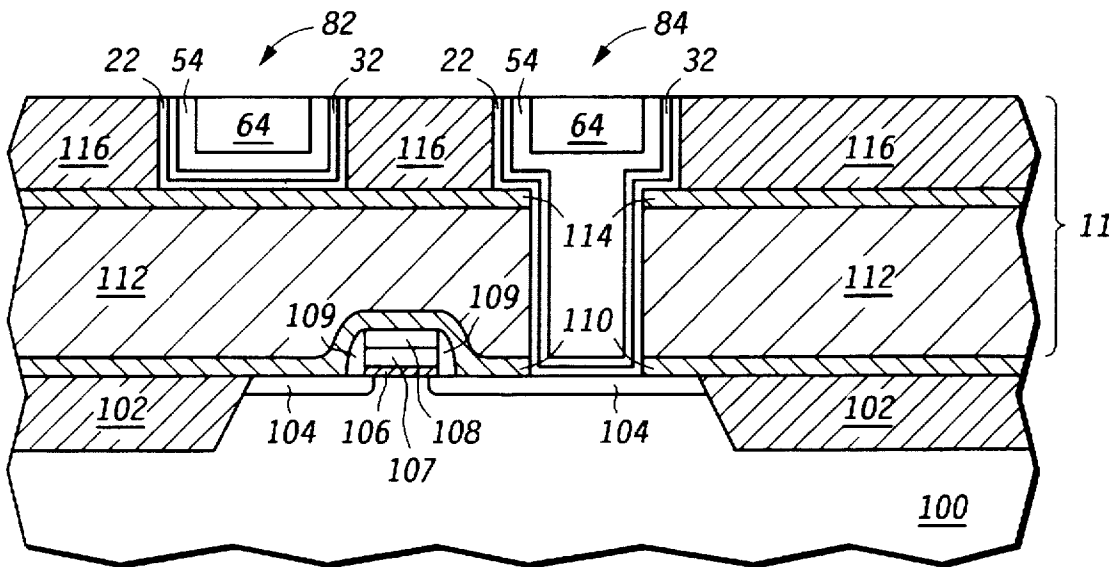

FIG. 8

Explore Litigation Insights

Docket Alarm provides insights to develop a more informed litigation strategy and the peace of mind of knowing you're on top of things.

Real-Time Litigation Alerts



Keep your litigation team up-to-date with **real-time alerts** and advanced team management tools built for the enterprise, all while greatly reducing PACER spend.

Our comprehensive service means we can handle Federal, State, and Administrative courts across the country.

Advanced Docket Research



With over 230 million records, Docket Alarm's cloud-native docket research platform finds what other services can't. Coverage includes Federal, State, plus PTAB, TTAB, ITC and NLRB decisions, all in one place.

Identify arguments that have been successful in the past with full text, pinpoint searching. Link to case law cited within any court document via Fastcase.

Analytics At Your Fingertips



Learn what happened the last time a particular judge, opposing counsel or company faced cases similar to yours.

Advanced out-of-the-box PTAB and TTAB analytics are always at your fingertips.

API

Docket Alarm offers a powerful API (application programming interface) to developers that want to integrate case filings into their apps.

LAW FIRMS

Build custom dashboards for your attorneys and clients with live data direct from the court.

Automate many repetitive legal tasks like conflict checks, document management, and marketing.

FINANCIAL INSTITUTIONS

Litigation and bankruptcy checks for companies and debtors.

E-DISCOVERY AND LEGAL VENDORS

Sync your system to PACER to automate legal marketing.