



- [54] **DISTRIBUTED PROCESSING ARCHITECTURE FOR CONTROL OF BROADBAND AND NARROWBAND COMMUNICATIONS NETWORKS**
- [75] Inventors: **Thomas F. La Porta**, Thornwood, N.Y.; **Malathi Veeraraghavan**, Atlantic Heights, N.J.
- [73] Assignee: **AT&T Corp.**, Murray Hill, N.J.
- [21] Appl. No.: **298,287**
- [22] Filed: **Aug. 31, 1994**

Communications, Jun. 23-26, 1991, Denver, pp. 3.2.1-3.2.8.
 I. Faynberg, L. R. Gabuzda, M. P. Kaplan, M. V. Kolipakum, W. J. Rowe, A. L. Waxman, "The Support of Network Interworking and Distributed Context Switching in the IN Service Data Function Model", 2nd International Conference on Intelligence in Networks, France, Mar., 1992, pp. 11-16.
 S. Minzer, "A Signaling Protocol for Complex Multimedia Services", IEEE Journal on Selected Areas in Communications, vol. 9, No. 9, Dec. 1991. Pp. 1383-1394.
 M. Fukazawa, M. Wakamoto and M. W. Kim, "Intelligent Network Call Model for Broadband ISDN", ICC 1991, pp. 964-968.

Related U.S. Application Data

- [63] Continuation of Ser. No. 82,656, Jun. 25, 1993, abandoned.
- [51] Int. Cl.⁶ **H04J 3/12; H04L 12/16**
- [52] U.S. Cl. **370/58.2; 370/62; 370/68.1; 370/110.1; 379/157; 379/165**
- [58] Field of Search **370/58.1, 58.2, 58.3, 370/60, 60.1, 62, 68.1, 110.1; 379/94, 157, 158, 165, 202**

Primary Examiner—Melvin Marcelo
Attorney, Agent, or Firm—John A. Caccuro

[57] **ABSTRACT**

A distributed, server-based communications network architecture delivers broadband and narrowband communications services. In the architecture, various traditional call processing functions, such as switching fabric or channel control, call control, and connection control are separated into distinct application processes which are clearly defined interfaces for communications between these application processes. Those distinct application processes may be implemented in separate physical or logically partitioned nodes. The well-defined interfaces allow communications among: a) physical or logically partitioned nodes within a network and b) physical or logically partitioned nodes of other networks.

[56] **References Cited**

U.S. PATENT DOCUMENTS

4,896,319	1/1990	Lidinsky et al.	370/60
5,036,318	7/1991	Bachhuber et al.	370/85.1 X
5,218,602	6/1993	Grant et al.	370/58.2
5,291,479	3/1994	Vaziri et al.	370/58.2

OTHER PUBLICATIONS

C. Woodworth, M. J. Karol, R. D. Gitlin, "A Flexible Broadband Packet Switch for a Multimedia INtegrated Network", Proceedings International Conference on

12 Claims, 5 Drawing Sheets

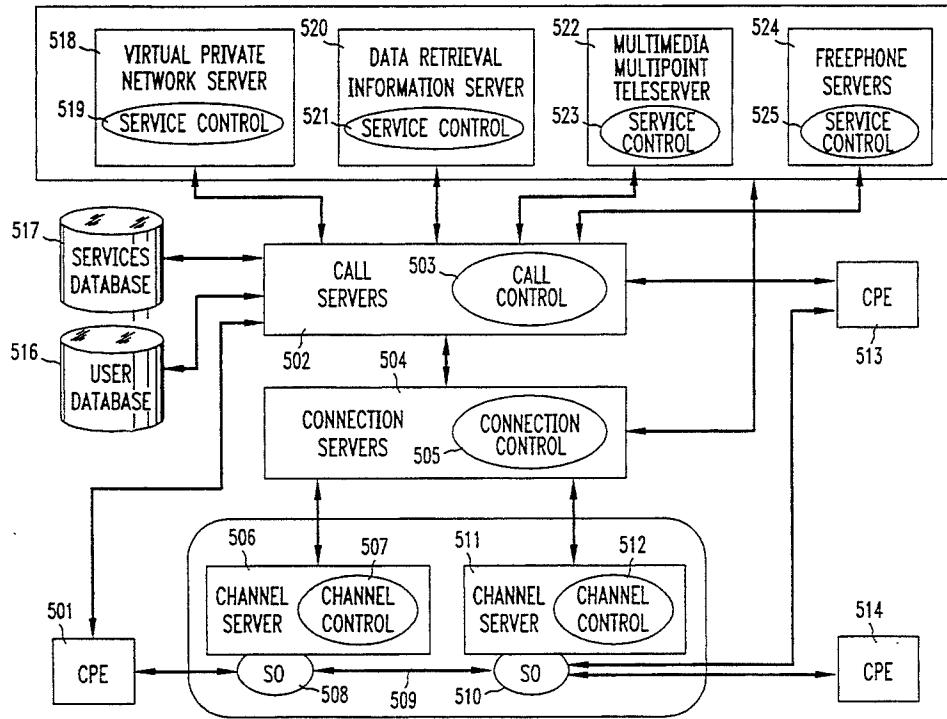

FIG. 1

OBJECT	IDENTIFYING ATTRIBUTES	NON-IDENTIFYING ATTRIBUTES
CALL	CALL REFERENCE VALUE	SERVER IDENTIFIERS(R) USER IDENTIFIERS(R)
CONNECTION	VIRTUAL CHANNEL CONNECTION IDENTIFIER	CONNECTION PERFORMANCE ATTRIBUTES AAL PROTOCOL TYPE(BEARER CAPABILITY) DIRECTIONALITY AND SYMMETRY USER IDENTIFIERS(R) SWITCH IDENTIFIERS(R) CHANNEL IDENTIFIERS(R)
CHANNEL	USER IDENTIFIER SWITCH IDENTIFIER TWO PORT NUMBERS VPCI/VCI	ATM LAYER BEARER CAPABILITY CHANNEL PERFORMANCE ATTRIBUTES
ROUTE	ROUTE NUMBER	PERFORMANCE ATTRIBUTES BANDWIDTH DIRECTIONALITY AND SYMMETRY USER IDENTIFIERS(R) SWITCH IDENTIFIERS(R) CHANNEL IDENTIFIERS(R)
CALL CONNECTION MAPPING	CRV VCCI	
VCI TRANSLATION TABLE ENTRY	CHANNEL IDENTIFIER CHANNEL IDENTIFIER	VCCI(R)
USER-CALL-INTERACTION (SERVER-CALL-INTERACTION)	CRV USER IDENTIFIER (SERVER IDENTIFIER)	VCCIs CONNECTION ATTRIBUTES SERVICE IDENTIFIERS SERVICE-SPECIFIC PARAMETERS USER IDENTIFIERS USER-SPECIFIC PARAMETERS DIVERGENCE FLAG SYNCHRONIZATION FLAG NEGOTIATION OPTIONS MODIFICATION MANDATORY OR OPTIONAL ADD USER FLAG DELETE USER FLAG CHANGE QOS OR BW FLAG SUCCESS FLAG FAILURE FLAG

FIG. 2

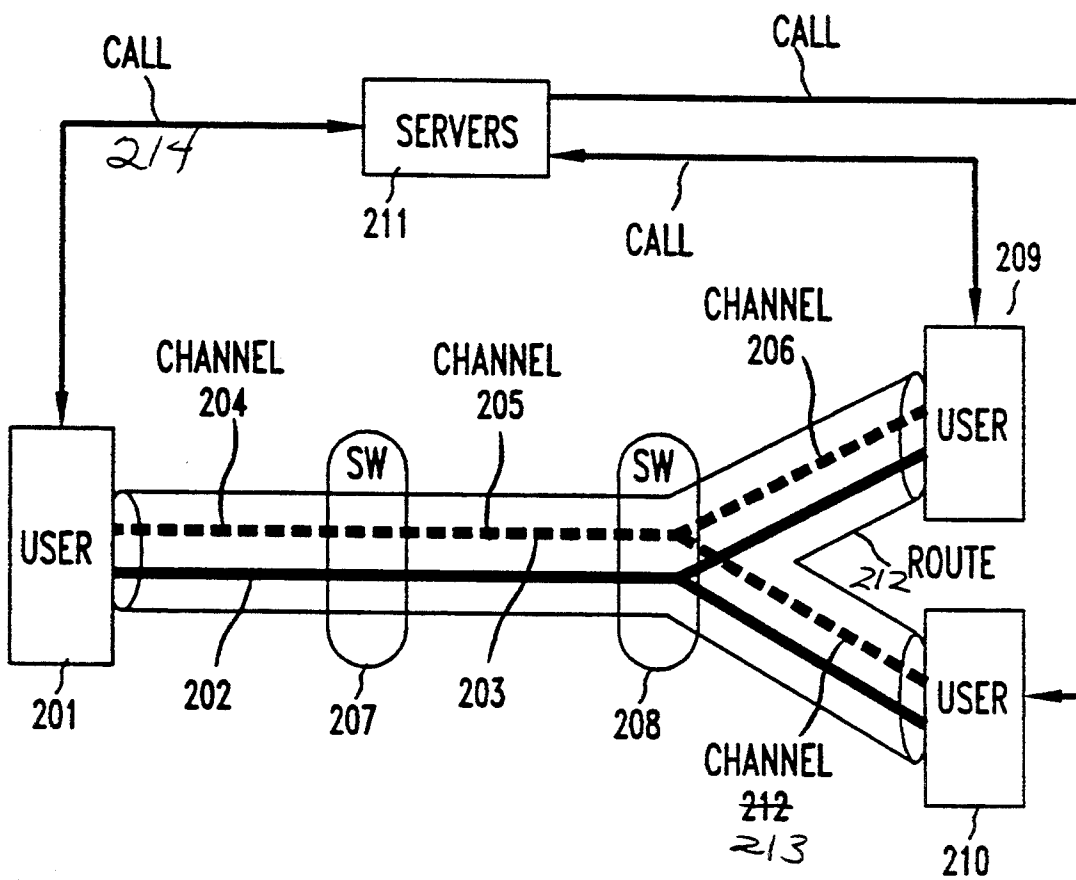

FIG. 3

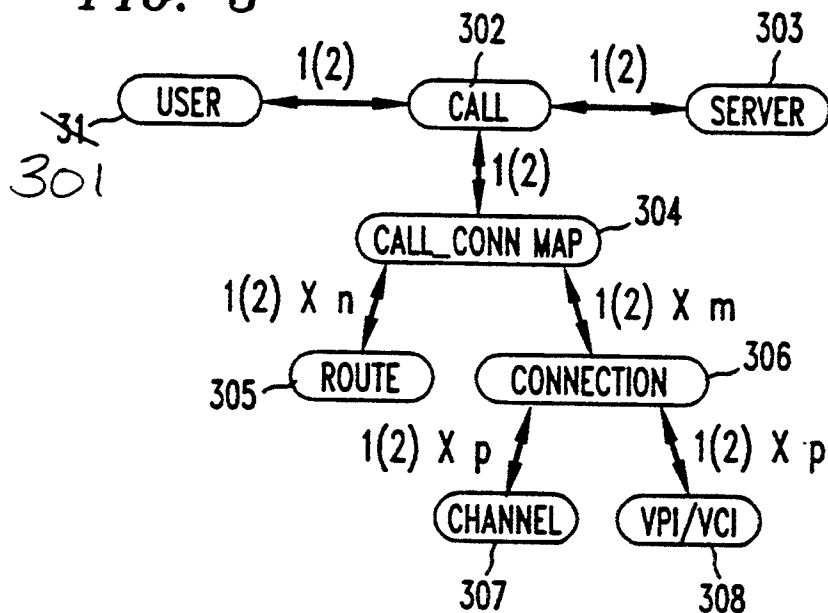
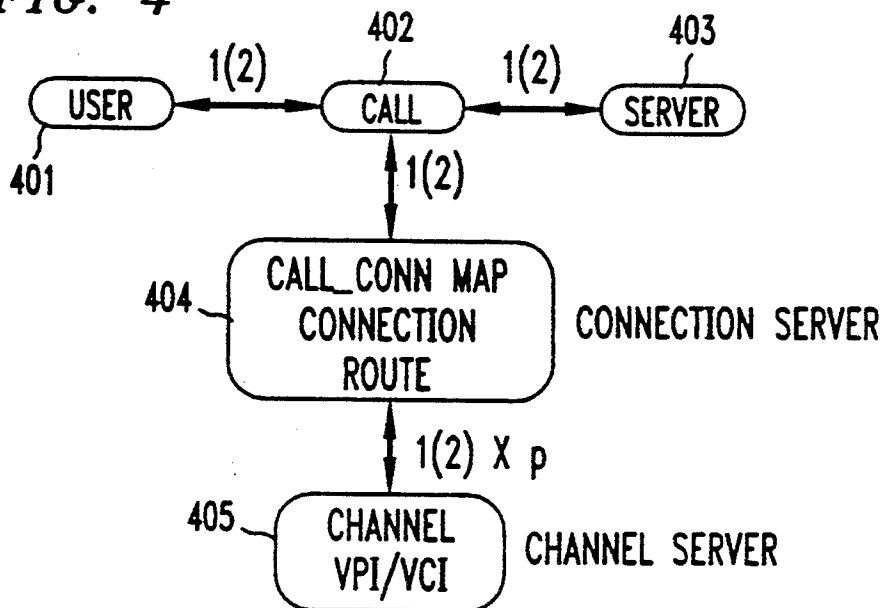

FIG. 4



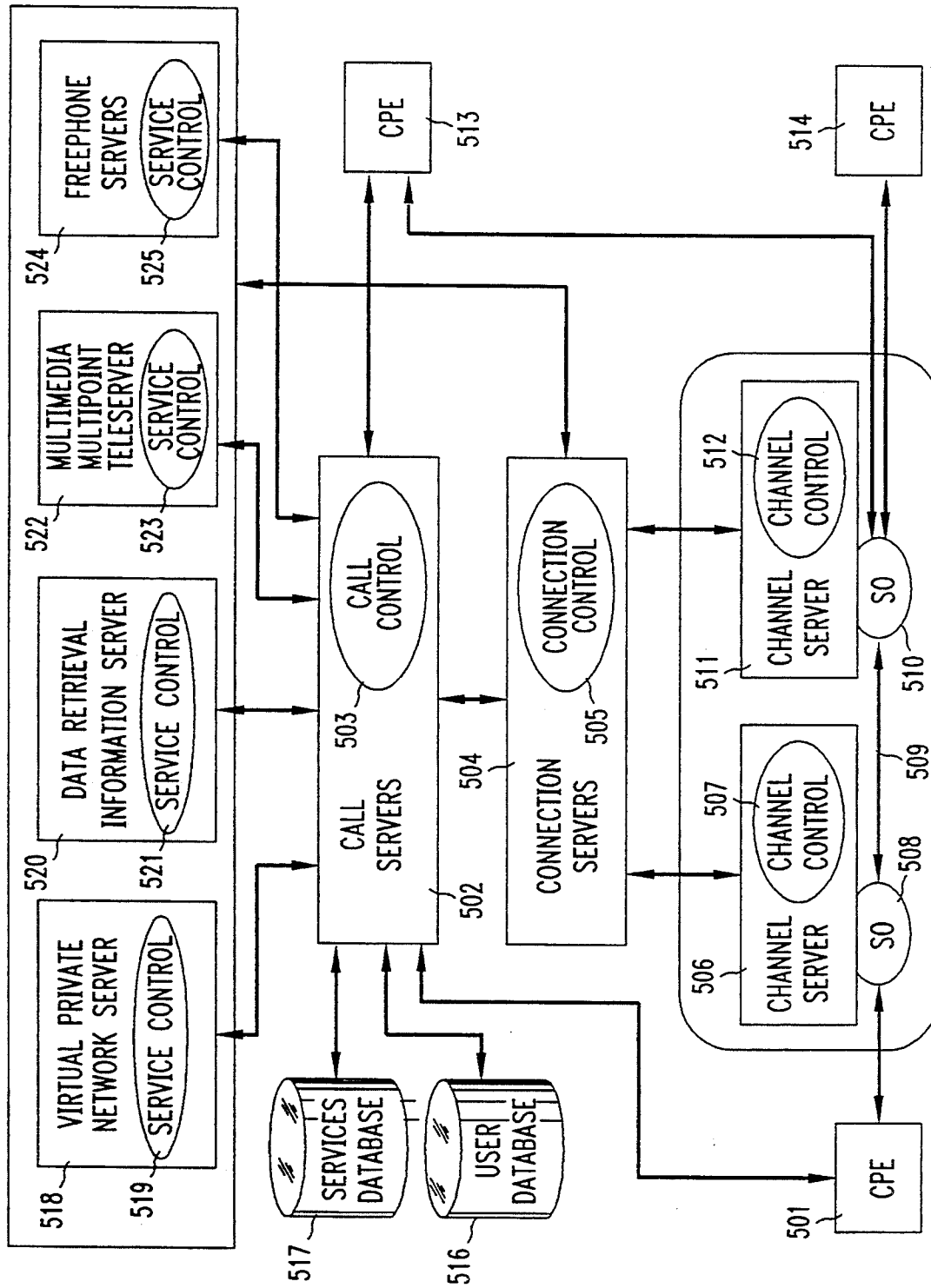

FIG. 5

Explore Litigation Insights

Docket Alarm provides insights to develop a more informed litigation strategy and the peace of mind of knowing you're on top of things.

Real-Time Litigation Alerts



Keep your litigation team up-to-date with **real-time alerts** and advanced team management tools built for the enterprise, all while greatly reducing PACER spend.

Our comprehensive service means we can handle Federal, State, and Administrative courts across the country.

Advanced Docket Research



With over 230 million records, Docket Alarm's cloud-native docket research platform finds what other services can't. Coverage includes Federal, State, plus PTAB, TTAB, ITC and NLRB decisions, all in one place.

Identify arguments that have been successful in the past with full text, pinpoint searching. Link to case law cited within any court document via Fastcase.

Analytics At Your Fingertips



Learn what happened the last time a particular judge, opposing counsel or company faced cases similar to yours.

Advanced out-of-the-box PTAB and TTAB analytics are always at your fingertips.

API

Docket Alarm offers a powerful API (application programming interface) to developers that want to integrate case filings into their apps.

LAW FIRMS

Build custom dashboards for your attorneys and clients with live data direct from the court.

Automate many repetitive legal tasks like conflict checks, document management, and marketing.

FINANCIAL INSTITUTIONS

Litigation and bankruptcy checks for companies and debtors.

E-DISCOVERY AND LEGAL VENDORS

Sync your system to PACER to automate legal marketing.