



UNITED STATES PATENT AND TRADEMARK OFFICE

UNITED STATES DEPARTMENT OF COMMERCE  
United States Patent and Trademark Office  
Address: COMMISSIONER FOR PATENTS  
P.O. Box 1450  
Alexandria, Virginia 22313-1450  
www.uspto.gov

APPLICATION NUMBER	FILING OR 371(C) DATE	FIRST NAMED APPLICANT	ATTY. DOCKET NO./TITLE
11/948,965	11/30/2007	Samuel F. Wood	357323-990125

**CONFIRMATION NO. 3783**

26379  
DLA PIPER LLP (US )  
2000 UNIVERSITY AVENUE  
EAST PALO ALTO, CA 94303-2248

**POWER OF ATTORNEY NOTICE**



\*OC000000070952567\*

Date Mailed: 09/25/2014

**NOTICE REGARDING CHANGE OF POWER OF ATTORNEY**

This is in response to the Power of Attorney filed 09/19/2014.

- The Power of Attorney to you in this application has been revoked by the assignee who has intervned as provided by 37 CFR 3.71. Future correspondence will be mailed to the new address of record(37 CFR 1.33).

/dtinh/

Office of Data Management, Application Assistance Unit (571) 272-4000, or (571) 272-4200, or 1-888-786-0101



UNITED STATES PATENT AND TRADEMARK OFFICE

UNITED STATES DEPARTMENT OF COMMERCE  
United States Patent and Trademark Office  
Address: COMMISSIONER FOR PATENTS  
P.O. Box 1450  
Alexandria, Virginia 22313-1450  
www.uspto.gov

APPLICATION NUMBER	FILING OR 371(C) DATE	FIRST NAMED APPLICANT	ATTY. DOCKET NO./TITLE
11/948,965	11/30/2007	Samuel F. Wood	002964.P075

**CONFIRMATION NO. 3783**

**POA ACCEPTANCE LETTER**

8791  
BLAKELY SOKOLOFF TAYLOR & ZAFMAN  
1279 Oakmead Parkway  
Sunnyvale, CA 94085-4040



Date Mailed: 09/25/2014

**NOTICE OF ACCEPTANCE OF POWER OF ATTORNEY**

This is in response to the Power of Attorney filed 09/19/2014.

The Power of Attorney in this application is accepted. Correspondence in this application will be mailed to the above address as provided by 37 CFR 1.33.

/dtinh/

Office of Data Management, Application Assistance Unit (571) 272-4000, or (571) 272-4200, or 1-888-786-0101

<b>PATENT - POWER OF ATTORNEY OR REVOCAION OF POWER OF ATTORNEY WITH A NEW POWER OF ATTORNEY AND CHANGE OF CORRESPONDENCE ADDRESS</b>	Patent Number	7,764,777
	Issue Date	July 27, 2010
	First Named Inventor	Samuel F. Wood
	Title	Branch Calling and Caller ID Based Call Routing Telephone Features
	Attorney Docket Number	002964.P075

I hereby revoke all previous powers of attorney given in the above-identified patent.

A Power of Attorney is submitted herewith.

OR

I hereby appoint Practitioner(s) associated with the following Customer Number as my/our attorney(s) or agent(s) with respect to the patent identified above, and to transact all business in the United States Patent and Trademark Office connected therewith: 08791

OR

I hereby appoint Practitioner(s) named below as my/our attorney(s) or agent(s) with respect to the patent identified above, and to transact all business in the United States Patent and Trademark Office connected therewith:

Practitioner(s) Name	Registration Number

Please recognize or change the correspondence address for the above-identified patent to:

The address associated with the above-mentioned Customer Number.

OR

The address associated with Customer Number:

OR

Firm or Individual Name

Address

City State Zip

Country

Telephone Email

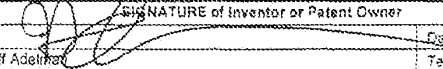
I am the:

Inventor, having ownership of the patent.

OR

Patent owner, Statement under 37 CFR 3.73(b) (Form PTO/SB/56) submitted herewith or filed on \_\_\_\_\_

SIGNATURE of Inventor or Patent Owner

Signature		Date	6/26/2014
Name	Jeff Adelstein	Telephone	(323) 860-9200
Title and Company	Manager, Focal IP, LLC		

NOTE: Signatures of all the inventors or patent owners of the entire interest or their representative(s) are required. Submit multiple forms if more than one signature is required, see below.

Total of \_\_\_\_\_ forms are submitted.

This collection of information is required by 37 CFR 1.31, 1.32 and 1.33. The information is required to obtain or retain a benefit by the public which is to file (and by the USPTO to process) an application. Confidentiality is governed by 35 U.S.C. 122 and 37 CFR 1.11 and 1.14. This collection is estimated to take 3 minutes to complete, including gathering, preparing, and submitting the completed application form to the USPTO. Time will vary depending upon the individual case. Any comments on the amount of time you require to complete this form and/or suggestions for reducing this burden, should be sent to the Chief Information Officer, U.S. Patent and Trademark Office, U.S. Department of Commerce, P.O. Box 1450, Alexandria, VA 22313-1450. DO NOT SEND FEES OR COMPLETED FORMS TO THIS ADDRESS. SEND TO: Commissioner for Patents, P.O. Box 1450, Alexandria, VA 22313-1450.

*If you need assistance in completing the form, call 1-800-PTO-9196 and select option 2.*

**STATEMENT UNDER 37 CFR 3.73(b)**Applicant/Patent Owner: Focal IP, LLCApplication No./Patent No.: 7,764,777 Filed/Issue Date: July 27, 2010

Titled:

Focal IP, LLC, a limited liability company  
 (Name of Assignee) (Type of Assignee, e.g., corporation, partnership, university, government agency, etc.)

states that it is:

1.  the assignee of the entire right, title, and interest in;
2.  an assignee of less than the entire right, title, and interest in  
 (The extent (by percentage) of its ownership interest is \_\_\_\_\_ %); or
3.  the assignee of an undivided interest in the entirety of (a complete assignment from one of the joint inventors was made)

the patent application/patent identified above, by virtue of either:

- A.  An assignment from the inventor(s) of the patent application/patent identified above. The assignment was recorded in the United States Patent and Trademark Office at Reel \_\_\_\_\_, Frame \_\_\_\_\_, or for which a copy therefore is attached.

OR

- B.  A chain of title from the inventor(s), of the patent application/patent identified above, to the current assignee as follows:

1. From: Wood, Samuel F., Klein, Jerry A. To: Telemaze, Inc.

The document was recorded in the United States Patent and Trademark Office at  
 Reel 014034, Frame 0043, or for which a copy thereof is attached.

2. From: Asprey, Margaret Susan To: Telemaze, Inc.

The document was recorded in the United States Patent and Trademark Office at  
 Reel 015613, Frame 0259, or for which a copy thereof is attached.

3. From: Telemaze, Inc. To: Telemaze LLC

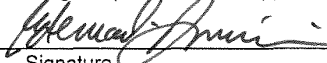
The document was recorded in the United States Patent and Trademark Office at  
 Reel 016844, Frame 0708, or for which a copy thereof is attached.

- Additional documents in the chain of title are listed on a supplemental sheet(s).

- As required by 37 CFR 3.73(b)(1)(i), the documentary evidence of the chain of title from the original owner to the assignee was, or concurrently is being, submitted for recordation pursuant to 37 CFR 3.11.

[NOTE: A separate copy (i.e., a true copy of the original assignment document(s)) must be submitted to Assignment Division in accordance with 37 CFR Part 3, to record the assignment in the records of the USPTO. See MPEP 302.08]

The undersigned (whose title is supplied below) is authorized to act on behalf of the assignee.

  
 Signature

September 19, 2014  
 Date

Farzad E. Amini, Reg. No. 42,261  
 Printed or Typed Name

Attorney for Patent Owner  
 Title

This collection of information is required by 37 CFR 3.73(b). The information is required to obtain or retain a benefit by the public which is to file (and by the USPTO to process) an application. Confidentiality is governed by 35 U.S.C. 122 and 37 CFR 1.11 and 1.14. This collection is estimated to take 12 minutes to complete, including gathering, preparing, and submitting the completed application form to the USPTO. Time will vary depending upon the individual case. Any comments on the amount of time you require to complete this form and/or suggestions for reducing this burden, should be sent to the Chief Information Officer, U.S. Patent and Trademark Office, U.S. Department of Commerce, P.O. Box 1450, Alexandria, VA 22313-1450. DO NOT SEND FEES OR COMPLETED FORMS TO THIS ADDRESS. SEND TO: Commissioner for Patents, P.O. Box 1450, Alexandria, VA 22313-1450.

If you need assistance in completing the form, call 1-800-PTO-9199 and select option 2.



B. A chain of title from the inventor(s) of the patent application/patent identified above, to the current assignee as follows: (CONTINUED)

4. From: Telemaze, LLC To: Focal IP, LLC

The document was recorded in the United States Patent and Trademark Office at

Reel 032350, Frame 0542

## Electronic Acknowledgement Receipt

<b>EFS ID:</b>	20193535
<b>Application Number:</b>	11948965
<b>International Application Number:</b>	
<b>Confirmation Number:</b>	3783
<b>Title of Invention:</b>	BRANCH CALLING AND CALLER ID BASED CALL ROUTING TELEPHONE FEATURES
<b>First Named Inventor/Applicant Name:</b>	Samuel F. Wood
<b>Customer Number:</b>	26379
<b>Filer:</b>	Farzad Etemad Amini/Margaux Wolson
<b>Filer Authorized By:</b>	Farzad Etemad Amini
<b>Attorney Docket Number:</b>	357323-990125
<b>Receipt Date:</b>	19-SEP-2014
<b>Filing Date:</b>	30-NOV-2007
<b>Time Stamp:</b>	16:28:35
<b>Application Type:</b>	Utility under 35 USC 111(a)

### Payment information:

Submitted with Payment	no
------------------------	----

### File Listing:

Document Number	Document Description	File Name	File Size(Bytes)/ Message Digest	Multi Part /.zip	Pages (if appl.)
1	Power of Attorney	2964P075_PatentPOA_RevChange_09_19_14.pdf	700376 <small>e00ce435a4de6d58a3000d6e30ebcbdac5f89e75</small>	no	1

### Warnings:

### Information:

2	Assignee showing of ownership per 37 CFR 3.73.	2964P075_State37CFR373b_09_19_14.pdf	73186 <small>5144820130ff464f5bbdb87a48502a9768c3c14</small>	no	2
---	--	--------------------------------------	---	----	---

**Warnings:**

**Information:**

<b>Total Files Size (in bytes):</b>	773562
-------------------------------------	--------

**This Acknowledgement Receipt evidences receipt on the noted date by the USPTO of the indicated documents, characterized by the applicant, and including page counts, where applicable. It serves as evidence of receipt similar to a Post Card, as described in MPEP 503.**

**New Applications Under 35 U.S.C. 111**

**If a new application is being filed and the application includes the necessary components for a filing date (see 37 CFR 1.53(b)-(d) and MPEP 506), a Filing Receipt (37 CFR 1.54) will be issued in due course and the date shown on this Acknowledgement Receipt will establish the filing date of the application.**

**National Stage of an International Application under 35 U.S.C. 371**

**If a timely submission to enter the national stage of an international application is compliant with the conditions of 35 U.S.C. 371 and other applicable requirements a Form PCT/DO/EO/903 indicating acceptance of the application as a national stage submission under 35 U.S.C. 371 will be issued in addition to the Filing Receipt, in due course.**

**New International Application Filed with the USPTO as a Receiving Office**

**If a new international application is being filed and the international application includes the necessary components for an international filing date (see PCT Article 11 and MPEP 1810), a Notification of the International Application Number and of the International Filing Date (Form PCT/RO/105) will be issued in due course, subject to prescriptions concerning national security, and the date shown on this Acknowledgement Receipt will establish the international filing date of the application.**



UNITED STATES PATENT AND TRADEMARK OFFICE

UNITED STATES DEPARTMENT OF COMMERCE  
United States Patent and Trademark Office  
Address: COMMISSIONER FOR PATENTS  
P.O. Box 1450  
Alexandria, Virginia 22313-1450  
www.uspto.gov

APPLICATION NUMBER	FILING OR 371(C) DATE	FIRST NAMED APPLICANT	ATTY. DOCKET NO./TITLE
11/948,965	11/30/2007	Samuel F. Wood	357323-990125

**CONFIRMATION NO. 3783**

26379  
DLA PIPER LLP (US )  
2000 UNIVERSITY AVENUE  
EAST PALO ALTO, CA 94303-2248

**MISCELLANEOUS NOTICE**



Date Mailed: 09/10/2014

A communication which cannot be delivered in electronic form has been mailed to the applicant.


**UNITED STATES PATENT AND TRADEMARK OFFICE**

UNITED STATES DEPARTMENT OF COMMERCE  
 United States Patent and Trademark Office  
 Address: COMMISSIONER FOR PATENTS  
 P.O. Box 1450  
 Alexandria, Virginia 22313-1450  
 www.uspto.gov

APPLICATION NUMBER	FILING DATE	FIRST NAMED APPLICANT	ATTY. DOCKET NO./TITLE
11/948,965	11/30/2007	Samuel F. Wood	357323-990125

**CONFIRMATION NO. 3783**

26379  
 DLA PIPER LLP (US )  
 2000 UNIVERSITY AVENUE  
 EAST PALO ALTO, CA 94303-2248



\*OC000000070666683\*

Cc: BLAKELY SOKOLOFF TAYLOR & ZAFMAN  
 1279 OAKMEAD PARKWAY  
 SUNNYVALE, CA 94085-4040

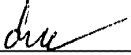
Date Mailed: 09/09/2014

**DENIAL OF REQUEST FOR POWER OF ATTORNEY**

The request for Power of Attorney filed 08/25/2014 is acknowledged. However, the request cannot be granted at this time for the reason stated below.

- The Power of Attorney you provided did not comply with the new Power of Attorney rules that became effective on June 25, 2004. See 37 CFR 1.32.
- The revocation is not signed by the applicant, the assignee of the entire interest, or one particular principal attorney having the authority to revoke.
- The Power of Attorney is from an assignee and the Certificate required by 37 CFR 3.73(b) has not been received.
- The person signing for the assignee has omitted their empowerment to sign on behalf of the assignee.
- The inventor(s) is without authority to appoint attorneys since the assignee has intervened as provided by 37 CFR 3.71.
- The signature(s) of \_\_\_\_\_, a co-inventor in this application, has been omitted. The Power of Attorney will be entered upon receipt of confirmation signed by said co-inventor(s).
- The person(s) appointed in the Power of Attorney is not registered to practice before the U.S. Patent and Trademark Office.

Questions relating to this Notice should be directed to the Application Assistance Unit.

  
 Office of Data Management, Application Assistance Unit (571) 272-4000, or (571) 272-4200, or 1-888-786-0101

<b>PATENT - POWER OF ATTORNEY OR REVOCATION OF POWER OF ATTORNEY WITH A NEW POWER OF ATTORNEY AND CHANGE OF CORRESPONDENCE ADDRESS</b>	Patent Number	7,764,777
	Issue Date	July 27, 2010
	First Named Inventor	Samuel F. Wood
	Title	Branch Calling and Caller ID Based Call Routing Telephone Features
	Attorney Docket Number	002964.P075

I hereby revoke all previous powers of attorney given in the above-identified patent.

A Power of Attorney is submitted herewith.

OR

I hereby appoint Practitioner(s) associated with the following Customer Number as my/our attorney(s) or agent(s) with respect to the patent identified above, and to transact all business in the United States Patent and Trademark Office connected therewith: 08791

OR

I hereby appoint Practitioner(s) named below as my/our attorney(s) or agent(s) with respect to the patent identified above, and to transact all business in the United States Patent and Trademark Office connected therewith:

Practitioner(s) Name	Registration Number

Please recognize or change the correspondence address for the above-identified patent to:

The address associated with the above-mentioned Customer Number.

OR

The address associated with Customer Number:

OR

Firm or Individual Name

Address

City State Zip

Country

Telephone Email

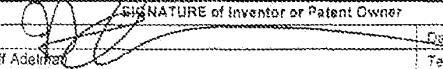
I am the:

Inventor, having ownership of the patent.

OR

Patent owner, Statement under 37 CFR 3.73(b) (Form PTO/SB/56) submitted herewith or filed on \_\_\_\_\_

SIGNATURE of Inventor or Patent Owner

Signature		Date	6/26/2014
Name	Jeff Adelstein	Telephone	(323) 860-9200
Title and Company	Manager, Focal IP, LLC		

NOTE: Signatures of all the inventors or patent owners of the entire interest or their representatives are required. Submit multiple forms if more than one signature is required, see below.

Total of \_\_\_\_\_ forms are submitted.

This collection of information is required by 37 CFR 1.31, 1.32 and 1.33. The information is required to obtain or retain a benefit by the public which is to file (and by the USPTO to process) an application. Confidentiality is governed by 35 U.S.C. 122 and 37 CFR 1.11 and 1.14. This collection is estimated to take 3 minutes to complete, including gathering, preparing, and submitting the completed application form to the USPTO. Time will vary depending upon the individual case. Any comments on the amount of time you require to complete this form and/or suggestions for reducing this burden, should be sent to the Chief Information Officer, U.S. Patent and Trademark Office, U.S. Department of Commerce, P.O. Box 1450, Alexandria, VA 22313-1450. DO NOT SEND FEES OR COMPLETED FORMS TO THIS ADDRESS. SEND TO: Commissioner for Patents, P.O. Box 1450, Alexandria, VA 22313-1450.

*If you need assistance in completing the form, call 1-800-PTO-9196 and select option 2.*

## Electronic Acknowledgement Receipt

<b>EFS ID:</b>	19958280
<b>Application Number:</b>	11948965
<b>International Application Number:</b>	
<b>Confirmation Number:</b>	3783
<b>Title of Invention:</b>	BRANCH CALLING AND CALLER ID BASED CALL ROUTING TELEPHONE FEATURES
<b>First Named Inventor/Applicant Name:</b>	Samuel F. Wood
<b>Customer Number:</b>	26379
<b>Filer:</b>	Farzad Etemad Amini/Margaux Wolson
<b>Filer Authorized By:</b>	Farzad Etemad Amini
<b>Attorney Docket Number:</b>	357323-990125
<b>Receipt Date:</b>	25-AUG-2014
<b>Filing Date:</b>	30-NOV-2007
<b>Time Stamp:</b>	17:05:03
<b>Application Type:</b>	Utility under 35 USC 111(a)

### Payment information:

Submitted with Payment	no
------------------------	----

### File Listing:

Document Number	Document Description	File Name	File Size(Bytes)/ Message Digest	Multi Part /.zip	Pages (if appl.)
1	Power of Attorney	2964P075_PatentPOA_RevChange_08_25_14.pdf	700370 c3561a1d6c50c4713af983f782baad240ba5a34e	no	1

### Warnings:

### Information:

This Acknowledgement Receipt evidences receipt on the noted date by the USPTO of the indicated documents, characterized by the applicant, and including page counts, where applicable. It serves as evidence of receipt similar to a Post Card, as described in MPEP 503.

**New Applications Under 35 U.S.C. 111**

If a new application is being filed and the application includes the necessary components for a filing date (see 37 CFR 1.53(b)-(d) and MPEP 506), a Filing Receipt (37 CFR 1.54) will be issued in due course and the date shown on this Acknowledgement Receipt will establish the filing date of the application.

**National Stage of an International Application under 35 U.S.C. 371**

If a timely submission to enter the national stage of an international application is compliant with the conditions of 35 U.S.C. 371 and other applicable requirements a Form PCT/DO/EO/903 indicating acceptance of the application as a national stage submission under 35 U.S.C. 371 will be issued in addition to the Filing Receipt, in due course.

**New International Application Filed with the USPTO as a Receiving Office**

If a new international application is being filed and the international application includes the necessary components for an international filing date (see PCT Article 11 and MPEP 1810), a Notification of the International Application Number and of the International Filing Date (Form PCT/RO/105) will be issued in due course, subject to prescriptions concerning national security, and the date shown on this Acknowledgement Receipt will establish the international filing date of the application.





UNITED STATES PATENT AND TRADEMARK OFFICE

UNITED STATES DEPARTMENT OF COMMERCE
United States Patent and Trademark Office
Address: COMMISSIONER FOR PATENTS
P.O. Box 1450
Alexandria, Virginia 22313-1450
www.uspto.gov

Table with 5 columns: APPLICATION NO., FILING DATE, FIRST NAMED INVENTOR, ATTORNEY DOCKET NO., CONFIRMATION NO. Includes sub-tables for EXAMINER, ART UNIT, PAPER NUMBER, NOTIFICATION DATE, and DELIVERY MODE.

Please find below and/or attached an Office communication concerning this application or proceeding.

The time period for reply, if any, is set in the attached communication.

Notice of the Office communication was sent electronically on above-indicated "Notification Date" to the following e-mail address(es):

PatentDocketingUS-PaloAlto@dlapiper.com



UNITED STATES PATENT AND TRADEMARK OFFICE

Commissioner for Patents  
United States Patent and Trademark Office  
P.O. Box 1450  
Alexandria, VA 22313-1450  
www.uspto.gov

In re Patent No. 7,764,777 :  
Issue Date: July 27, 2010 :  
Application No. 11/948,965 : NOTICE  
Filed: November 30, 2007 :  
Attorney Docket No. 357323-990125 :

This is a notice regarding your request, filed February 25, 2014, for acceptance of a fee deficiency submission under 37 CFR 1.28.

On September 1, 1998, the Court of Appeals for the Federal Circuit held that 37 CFR 1.28(c) is the sole provision governing the time for correction of the erroneous payment of the issue fee as a small entity. **See DH Technology v. Synergystex International, Inc. 154 F.3d 1333, 47 USPQ2d 1865 (Fed. Cir. Sept. 1, 1998).**

The Office no longer investigates or rejects original or reissue applications under 37 CFR 1.56. **1098 Off. Gaz. Pat. Office 502 (January 3, 1989).** Therefore, nothing in this Notice is intended to imply that an investigation was done.

Your fee deficiency submission under 37 CFR 1.28 is hereby **ACCEPTED**.

This patent is no longer entitled to small entity status. Accordingly, all future fees paid in this patent must be paid at the large entity rate.

*/Liana Walsh/*  
Liana Walsh  
Petitions Paralegal Specialist  
Office of Petitions

## Office of Petitions: Routing Sheet



**Application No. 11/948,965**

**This application is being forwarded to your office for further processing. A decision has been rendered on a petition filed in this application.**

**GRANTED**

**DISMISSED**

**DENIED**

Office of Petitions: Decision Count Sheet

Mailing Month

4

Application No.

11948965



For US serial numbers: enter number only, no slashes or commas. Ex: 10123456

For PCT: enter "51+single digit of year of filing+last 5 numbers", Ex. for PCT/US05/12345, enter 51512345

Deciding Official:

WALSH, LIANA

Count (1) - Palm Credit

11/948,965

FINANCE WORK NEEDED

Decision:

GRANT

Select Check Box for YES



Decision Type:

321 - 37 CFR 1.28 TO MAKE ENTITY STATUS LARGE FI



Notes:

Count (2)

Decision:

n/a

FINANCE WORK NEEDED

Select Check Box for YES

Decision Type:

NONE

Notes:

Count (3)

Decision:

n/a

FINANCE WORK NEEDED

Select Check Box for YES

Decision Type:

NONE

Notes:

Initials of Approving Official (if required)

If more than 3 decisions, attach 2nd count sheet & mark this box

Printed on: 4/25/2014

Office of Petitions Internal Document - Ver. 5.0

Atty. Docket No.: 002964.P075

IN THE UNITED STATES PATENT AND TRADEMARK OFFICE

In Re the application of:	)
Samuel F. Wood, et al.	) Examiner:
	)
Application No.: 11/948,965	) Art Unit:
	)
Filed: November 30, 2007	)
	) Confirmation No.: 3783
Patent No.: 7,764,777	)
	)
Issued: July 27, 2010	)
	)
For: BRANCH CALLING AND CALLER ID	)
BASED CALL ROUTING TELEPHONE	)
FEATURES	)
	)

**FEE DEFICIENCY SUBMISSION**

**Please fax to: Status & Entity Branch**  
**Office of Finance at 571-273-6500**  
 Commissioner for Patents  
 P.O. Box 1450  
 Alexandria, VA 22313-1450

Dear Sir:

This is a Fee Deficiency Submission for the above-identified patent.

02/27/2014 MBANGURA 00000015 022666 7764777  
 01 FC:1599 800.00 DA

**FEES PAID INSUFFICIENTLY**

Filing Date of Original Paper/Fee	Type of Fee Paid	Then Current Fee Amount as Large Entity	Amount Originally Paid	Amount of Fee Deficiency
January 23, 2014	Maintenance Fee	\$1,600.00	\$800.00	\$800.00

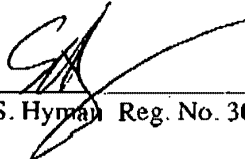
**EXPLANATION**

The patent was assigned to a large entity. Accordingly, Applicant has requested the Office of Finance change the entity size to large, and requests that any and all deficient fees due be charged to Deposit Account No. 02-2666.

Respectfully submitted,

BLAKELY, SOKOLOFF, TAYLOR & ZAFMAN

Dated: 2/25/2014

By:   
Eric S. Hyman Reg. No. 30,139

12400 Wilshire Boulevard  
Seventh Floor  
Los Angeles, California 90025  
(310) 207-3800

**CERTIFICATE OF FACSIMILE TRANSMISSION**  
I hereby certify that this correspondence is being submitted to the USPTO Office of Finance via facsimile at 571-273-6500 on the date shown below.

 2/25/2014  
Alexis Karriker Date

Please fax to: Status & Entity Branch, Office of Finance at 571-273-6500 or submit to:

Mail Stop M Correspondence  
Director of the US Patent and Trademark Office  
PO Box 1450  
Alexandria, VA 22313-1450

Re: US Patent No. 7,764,777  
Our Ref: 002964.P075

Dear Sir:

Please note that the applicant for the above-referenced patent qualifies as a **LARGE** entity.

Respectfully submitted,

BLAKELY, SOKOLOFF, TAYLOR & ZAFMAN

Dated: \_\_\_\_\_

*2/24/2014*

By: \_\_\_\_\_

*[Signature]*

Eric S. Hyman Reg. No. 30,139

12400 Wilshire Boulevard  
Seventh Floor  
Los Angeles, California 90025  
(310) 207-3800

**CERTIFICATE OF FACSIMILE TRANSMISSION**

I hereby certify that this correspondence is being submitted to the USPTO Office of Finance via facsimile at 571-273-6500 on the date shown below.

Alexis Karriker

*Alexis Karriker*

*2/24/14*

Date



UNITED STATES PATENT AND TRADEMARK OFFICE

UNITED STATES DEPARTMENT OF COMMERCE  
United States Patent and Trademark Office  
Address: COMMISSIONER FOR PATENTS  
P.O. Box 1450  
Alexandria, Virginia 22313-1450  
www.uspto.gov

APPLICATION NUMBER	FILING OR 371(C) DATE	FIRST NAMED APPLICANT	ATTY. DOCKET NO./TITLE
11/948,965	11/30/2007	Samuel F. Wood	357323.990125

26379  
DLA PIPER LLP (US )  
2000 UNIVERSITY AVENUE  
EAST PALO ALTO, CA 94303-2248

**CONFIRMATION NO. 3783**  
**POA ACCEPTANCE LETTER**



\*OC000000052007127\*

Date Mailed: 01/18/2012

**NOTICE OF ACCEPTANCE OF POWER OF ATTORNEY**

This is in response to the Power of Attorney filed 01/09/2012.

The Power of Attorney in this application is accepted. Correspondence in this application will be mailed to the above address as provided by 37 CFR 1.33.

/stephanos/

Office of Data Management, Application Assistance Unit (571) 272-4000, or (571) 272-4200, or 1-888-786-0101





UNITED STATES PATENT AND TRADEMARK OFFICE

UNITED STATES DEPARTMENT OF COMMERCE  
United States Patent and Trademark Office  
Address: COMMISSIONER FOR PATENTS  
P.O. Box 1450  
Alexandria, Virginia 22313-1450  
www.uspto.gov

APPLICATION NUMBER	FILING OR 371(C) DATE	FIRST NAMED APPLICANT	ATTY. DOCKET NO./TITLE
11/948,965	11/30/2007	Samuel F. Wood	TLM-103C1DIV

**CONFIRMATION NO. 3783**

**POWER OF ATTORNEY NOTICE**

49637  
BERRY & ASSOCIATES P.C.  
9229 SUNSET BOULEVARD  
SUITE 630  
LOS ANGELES, CA 90069



Date Mailed: 01/18/2012

**NOTICE REGARDING CHANGE OF POWER OF ATTORNEY**

This is in response to the Power of Attorney filed 01/09/2012.

- The Power of Attorney to you in this application has been revoked by the assignee who has intervned as provided by 37 CFR 3.71. Future correspondence will be mailed to the new address of record(37 CFR 1.33).

/fstephanos/

Office of Data Management, Application Assistance Unit (571) 272-4000, or (571) 272-4200, or 1-888-786-0101

Under the Paperwork Reduction Act of 1995, no persons are required to respond to a collection of information unless it displays a valid OMB control number.

<b>POWER OF ATTORNEY OR REVOCAION OF POWER OF ATTORNEY WITH A NEW POWER OF ATTORNEY AND CHANGE OF CORRESPONDENCE ADDRESS</b>	Patent Number	7,754,777
	Issue Date	July 27, 2010
	First Named Inventor	Wood
	Title	Branch Calling And Caller ID Based Call Routing Telephone Features
	Art Unit	2814
	Examiner Name	Smith, Craighton H.
Attorney Docket Number	567323-980125	

I hereby revoke all previous powers of attorney given in the above-identified application.

 A Power of Attorney is submitted herewith.

OR

 I hereby appoint Practitioner(s) associated with the following Customer Number as my/our attorney(s) or agent(s) to prosecute the application identified above, and to transact all business in the United States Patent and Trademark Office connected therewith:

26379

OR

 I hereby appoint Practitioner(s) named below as my/our attorney(s) or agent(s) to prosecute the application identified above, and to transact all business in the United States Patent and Trademark Office connected therewith:

Practitioner(s) Name	Registration Number

Please recognize or change the correspondence address for the above-identified application to:

 The address associated with the above-mentioned Customer Number.

OR

 The address associated with Customer Number.

OR

 Firm or Individual Name

Address

City

State

Zip

Country

Telephone

Email

I am the:

 Applicant/Inventor.

OR

 Assignee of record of the entire interest. See 37 CFR 3.71.

Statement under 37 CFR 3.73(b) (Form PTO/SB/06) submitted herewith or filed on \_\_\_\_\_

SIGNATURE of Applicant or Assignee of Record

Signature

Name

Title and Company

Date

Telephone

NOTE: Signatures of all the inventors or assignees of record of the entire interest or their representative(s) are required. Submit multiple forms if more than one signature is required, see below.

 \*Total of 1 forms are submitted.

This collection of information is required by 37 CFR 1.31, 1.32 and 1.33. The information is required to obtain or retain a benefit by the public which is to file (and by the USPTO to process) an application. Confidentiality is governed by 35 U.S.C. 122 and 37 CFR 1.11 and 1.14. This collection is estimated to take 3 minutes to complete, including gathering, preparing, and submitting the completed application form to the USPTO. Time will vary depending upon the individual case. Any comments on the amount of time you require to complete this form and/or suggestions for reducing this burden, should be sent to the Chief Information Officer, U.S. Patent and Trademark Office, U.S. Department of Commerce, P.O. Box 1450, Alexandria, VA 22313-1450. DO NOT SEND FEES OR COMPLETED FORMS TO THIS ADDRESS. SEND TO: Commissioner for Patents, P.O. Box 1450, Alexandria, VA 22313-1450.

If you need assistance in completing the form, call 1-800-PTO-9199 and select option 2.

American LegalNet, Inc.  
www.PatentPowerNow.com

**STATEMENT UNDER 37 CFR 3.73(b)**Applicant/Patent Owner: Wood, Samuel F.; Klein, Jerry A. & Asprey, Margaret SusanApplication No./Patent No.: 7,794,777 Filed/Issue Date: July 27, 2010Entitled: Branch Calling And Caller ID Based Call Routing Telephone Features

Telemaze LLC, a corporation

(Name of Assignee)

(Type of Assignee, e.g., corporation, partnership, university, government agency, etc.)

states that it is:

1.  the assignee of the entire right, title, and interest in;
2.  an assignee of less than the entire right, title and interest in  
(The extent (by percentage) of its ownership interest is \_\_\_\_\_ %); or
3.  the assignee of an undivided interest in the entirety of (a complete assignment from one of the joint inventors was made)

in the patent application/patent identified above by virtue of either:

- A.  An assignment from the inventor(s) of the patent application/patent identified above. The assignment was recorded in the United States Patent and Trademark Office at Reel \_\_\_\_\_, Frame \_\_\_\_\_, or for which a copy thereof is attached.

OR

- B.  A chain of title from the inventor(s), of the patent application/patent identified above, to the current assignee as follows:

1. From: Wood, Samuel F. & Klein, Jerry A. To: Telemaze, Inc.The document was recorded in the United States Patent and Trademark Office at  
Reel 014034, Frame 0043, or for which a copy thereof is attached.2. From: Asprey, Margaret Susan To: Telemaze, Inc.The document was recorded in the United States Patent and Trademark Office at  
Reel 015613, Frame 0259, or for which a copy thereof is attached.3. From: Telemaze, Inc. To: Telemaze LLCThe document was recorded in the United States Patent and Trademark Office at  
Reel 016844, Frame 0708, or for which a copy thereof is attached.

- Additional documents in the chain of title are listed on a supplemental sheet(s).

- As required by 37 CFR 3.73(b)(1)(i), the documentary evidence of the chain of title from the original owner to the assignee was, or concurrently is being, submitted for recordation pursuant to 37 CFR 3.11.

[NOTE: A separate copy (i.e., a true copy of the original assignment document(s)) must be submitted to Assignment Division in accordance with 37 CFR Part 3, to record the assignment in the records of the USPTO. See MPEP 302.06]

The undersigned (whose title is supplied below) is authorized to act on behalf of the assignee.

Signature

Jerry Klein

Printed or Typed Name

Date

1/5/12  
Managing Director,  
Telemaze LLC

Title

This collection of information is required by 37 CFR 3.73(b). The information is required to obtain or retain a benefit by the public which is to file (and by the USPTO to process) an application. Confidentiality is governed by 35 U.S.C. 122 and 37 CFR 1.11 and 1.14. This collection is estimated to take 12 minutes to complete, including gathering, preparing, and submitting the completed application form to the USPTO. Time will vary depending upon the individual case. Any comments on the amount of time you require to complete this form and/or suggestions for reducing this burden, should be sent to the Chief Information Officer, U.S. Patent and Trademark Office, U.S. Department of Commerce, P.O. Box 1460, Alexandria, VA 22310-1460. DO NOT SEND FEES OR COMPLETED FORMS TO THIS ADDRESS. SEND TO: Commissioner for Patents, P.O. Box 1460, Alexandria, VA 22313-1460.

If you need assistance in completing the form, call 1-800-PTO-9199 and select option 2.



## Electronic Acknowledgement Receipt

<b>EFS ID:</b>	11794868
<b>Application Number:</b>	11948965
<b>International Application Number:</b>	
<b>Confirmation Number:</b>	3783
<b>Title of Invention:</b>	BRANCH CALLING AND CALLER ID BASED CALL ROUTING TELEPHONE FEATURES
<b>First Named Inventor/Applicant Name:</b>	Samuel F. Wood
<b>Customer Number:</b>	49637
<b>Filer:</b>	Alan A. Limbach/Kathleen LaBrie
<b>Filer Authorized By:</b>	Alan A. Limbach
<b>Attorney Docket Number:</b>	TLM-103C1DIV
<b>Receipt Date:</b>	09-JAN-2012
<b>Filing Date:</b>	30-NOV-2007
<b>Time Stamp:</b>	19:03:32
<b>Application Type:</b>	Utility under 35 USC 111(a)

### Payment information:

Submitted with Payment	no
------------------------	----

### File Listing:

Document Number	Document Description	File Name	File Size(Bytes)/ Message Digest	Multi Part /.zip	Pages (if appl.)
1	Power of Attorney	990125_Power_of_Attorney. pdf	405132 <small>91f23a19d29f90100d432cfc572bf9a91c9455</small>	no	1

### Warnings:

### Information:

2	Assignee showing of ownership per 37 CFR 3.73(b).	990125_Statement_37CFR373.pdf	390766 6f711727cc3ccca739ba7145b06f771586c10cfd	no	1
---	---	-------------------------------	--	----	---

**Warnings:**

**Information:**

**Total Files Size (in bytes):** 795898

**This Acknowledgement Receipt evidences receipt on the noted date by the USPTO of the indicated documents, characterized by the applicant, and including page counts, where applicable. It serves as evidence of receipt similar to a Post Card, as described in MPEP 503.**

**New Applications Under 35 U.S.C. 111**

**If a new application is being filed and the application includes the necessary components for a filing date (see 37 CFR 1.53(b)-(d) and MPEP 506), a Filing Receipt (37 CFR 1.54) will be issued in due course and the date shown on this Acknowledgement Receipt will establish the filing date of the application.**

**National Stage of an International Application under 35 U.S.C. 371**

**If a timely submission to enter the national stage of an international application is compliant with the conditions of 35 U.S.C. 371 and other applicable requirements a Form PCT/DO/EO/903 indicating acceptance of the application as a national stage submission under 35 U.S.C. 371 will be issued in addition to the Filing Receipt, in due course.**

**New International Application Filed with the USPTO as a Receiving Office**

**If a new international application is being filed and the international application includes the necessary components for an international filing date (see PCT Article 11 and MPEP 1810), a Notification of the International Application Number and of the International Filing Date (Form PCT/RO/105) will be issued in due course, subject to prescriptions concerning national security, and the date shown on this Acknowledgement Receipt will establish the international filing date of the application.**



UNITED STATES PATENT AND TRADEMARK OFFICE

UNITED STATES DEPARTMENT OF COMMERCE  
United States Patent and Trademark Office  
Address: COMMISSIONER FOR PATENTS  
P.O. Box 1450  
Alexandria, Virginia 22313-1450  
www.uspto.gov

APPLICATION NO.	ISSUE DATE	PATENT NO.	ATTORNEY DOCKET NO.	CONFIRMATION NO.
11/948,965	07/27/2010	7764777	TLM-103C1DIV	3783

49637 7590 07/07/2010  
BERRY & ASSOCIATES P.C.  
9229 SUNSET BOULEVARD  
SUITE 630  
LOS ANGELES, CA 90069

**ISSUE NOTIFICATION**

The projected patent number and issue date are specified above.

**Determination of Patent Term Adjustment under 35 U.S.C. 154 (b)**  
(application filed on or after May 29, 2000)

The Patent Term Adjustment is 0 day(s). Any patent to issue from the above-identified application will include an indication of the adjustment on the front page.

If a Continued Prosecution Application (CPA) was filed in the above-identified application, the filing date that determines Patent Term Adjustment is the filing date of the most recent CPA.

Applicant will be able to obtain more detailed information by accessing the Patent Application Information Retrieval (PAIR) WEB site (<http://pair.uspto.gov>).

Any questions regarding the Patent Term Extension or Adjustment determination should be directed to the Office of Patent Legal Administration at (571)-272-7702. Questions relating to issue and publication fee payments should be directed to the Application Assistance Unit (AAU) of the Office of Data Management (ODM) at (571)-272-4200.

APPLICANT(s) (Please see PAIR WEB site <http://pair.uspto.gov> for additional applicants):

Samuel F. Wood, Los Altos Hills, CA;  
Jerry A. Klein, Los Altos, CA;  
Margaret Susan Asprey, Los Altos, CA;



UNITED STATES PATENT AND TRADEMARK OFFICE

UNITED STATES DEPARTMENT OF COMMERCE
United States Patent and Trademark Office
Address: COMMISSIONER FOR PATENTS
P.O. Box 1450
Alexandria, Virginia 22313-1450
www.uspto.gov

Table with 5 columns: APPLICATION NO., FILING DATE, FIRST NAMED INVENTOR, ATTORNEY DOCKET NO., CONFIRMATION NO.
11/948,965 11/30/2007 Samuel F. Wood TLM-103C1DIV 3783
BERRY & ASSOCIATES P.C. 9229 SUNSET BOULEVARD SUITE 630 LOS ANGELES, CA 90069
EXAMINER SMITH, CREIGHTON H
ART UNIT 2614 PAPER NUMBER
MAIL DATE 06/23/2010 DELIVERY MODE PAPER

NOTICE OF NON-COMPLIANT INFORMATION DISCLOSURE STATEMENT

An Information Disclosure Statement (IDS) filed 06-07-10 in the above-identified application fails to meet the requirements of 37 CFR 1.97(d) for the reason(s) specified below. Accordingly, the IDS will be placed in the file, but the information referred to therein has not been considered.

The IDS is not compliant with 37 CFR 1.97(d) because:

- [X] The IDS lacks a statement as specified in 37 CFR 1.97(e).
[] The IDS lacks the fee set forth in 37 CFR 1.17(p).
[] The IDS was filed after the issue fee was paid. Applicant may wish to consider filing a petition to withdraw the application from issue under 37 CFR 1.313(c) to have the IDS considered. See MPEP 1308.

571-272-4200 or 1-888-786-0101
Application Assistance Unit
Office of Data Management

Handwritten signature

**PART B - FEE(S) TRANSMITTAL**

**Complete and send this form, together with applicable fee(s), to: Mail Mail Stop ISSUE FEE  
 Commissioner for Patents  
 P.O. Box 1450  
 Alexandria, Virginia 22313-1450  
 or Fax (571)-273-2885**

**INSTRUCTIONS:** This form should be used for transmitting the ISSUE FEE and PUBLICATION FEE (if required). Blocks 1 through 5 should be completed where appropriate. All further correspondence including the Patent, advance orders and notification of maintenance fees will be mailed to the current correspondence address as indicated unless corrected below or directed otherwise in Block 1, by (a) specifying a new correspondence address; and/or (b) indicating a separate "FEE ADDRESS" for maintenance fee notifications.

CURRENT CORRESPONDENCE ADDRESS (Note: Use Block 1 for any change of address)

49637                      7590                      03/19/2010

**BERRY & ASSOCIATES P.C.**  
 9229 SUNSET BOULEVARD  
 SUITE 630  
 LOS ANGELES, CA 90069

Note: A certificate of mailing can only be used for domestic mailings of the Fee(s) Transmittal. This certificate cannot be used for any other accompanying papers. Each additional paper, such as an assignment or formal drawing, must have its own certificate of mailing or transmission.

**Certificate of Mailing or Transmission**

I hereby certify that this Fee(s) Transmittal is being deposited with the United States Postal Service with sufficient postage for first class mail in an envelope addressed to the Mail Stop ISSUE FEE address above, or being facsimile transmitted to the USPTO (571) 273-2885, on the date indicated below.

_____ (Depositor's name)
_____ (Signature)
_____ (Date)

APPLICATION NO.	FILING DATE	FIRST NAMED INVENTOR	ATTORNEY DOCKET NO.	CONFIRMATION NO.
-----------------	-------------	----------------------	---------------------	------------------

11/948,965                      11/30/2007                      Samuel F. Wood                      TLM-103C1DIV                      3783

TITLE OF INVENTION: BRANCH CALLING AND CALLER ID BASED CALL ROUTING TELEPHONE FEATURES

APPLN. TYPE	SMALL ENTITY	ISSUE FEE DUE	PUBLICATION FEE DUE	PREV. PAID ISSUE FEE	TOTAL FEE(S) DUE	DATE DUE
-------------	--------------	---------------	---------------------	----------------------	------------------	----------

nonprovisional                      YES                      \$755                      \$300                      \$0                      \$1055                      06/21/2010

EXAMINER	ART UNIT	CLASS-SUBCLASS
----------	----------	----------------

SMITH, CREIGHTON H                      2614                      379-142020

1. Change of correspondence address or indication of "Fee Address" (37 CFR 1.363). <input type="checkbox"/> Change of correspondence address (or Change of Correspondence Address form PTO/SB/122) attached. <input type="checkbox"/> "Fee Address" indication (or "Fee Address" Indication form PTO/SB/47; Rev 03-02 or more recent) attached. <b>Use of a Customer Number is required.</b>	2. For printing on the patent front page, list (1) the names of up to 3 registered patent attorneys or agents OR, alternatively, (2) the name of a single firm (having as a member a registered attorney or agent) and the names of up to 2 registered patent attorneys or agents. If no name is listed, no name will be printed.	1 <u>Berry &amp; Associates P.C.</u> 2 _____ 3 _____
--	---	--

3. ASSIGNEE NAME AND RESIDENCE DATA TO BE PRINTED ON THE PATENT (print or type)  
 PLEASE NOTE: Unless an assignee is identified below, no assignee data will appear on the patent. If an assignee is identified below, the document has been filed for recordation as set forth in 37 CFR 3.11. Completion of this form is NOT a substitute for filing an assignment.

(A) NAME OF ASSIGNEE                      (B) RESIDENCE: (CITY and STATE OR COUNTRY)  
**TELEMAZE LLC**                      **LOS ALTOS, CA**

Please check the appropriate assignee category or categories (will not be printed on the patent) :     Individual     Corporation or other private group entity     Government

4a. The following fee(s) are submitted: <input checked="" type="checkbox"/> Issue Fee <input checked="" type="checkbox"/> Publication Fee (No small entity discount permitted) <input checked="" type="checkbox"/> Advance Order - # of Copies <u>6</u>	4b. Payment of Fee(s): (Please first reapply any previously paid issue fee shown above) <input type="checkbox"/> A check is enclosed. <input type="checkbox"/> Payment by credit card. Form PTO-2038 is attached. <input checked="" type="checkbox"/> The Director is hereby authorized to charge the required fee(s), any deficiency, or credit any overpayment, to Deposit Account Number <u>50-3102</u> (enclose an extra copy of this form).
--	---

5. Change in Entity Status (from status indicated above)  
 a. Applicant claims SMALL ENTITY status. See 37 CFR 1.27.     b. Applicant is no longer claiming SMALL ENTITY status. See 37 CFR 1.27(g)(2).

NOTE: The Issue Fee and Publication Fee (if required) will not be accepted from anyone other than the applicant; a registered attorney or agent; or the assignee or other party in interest as shown by the records of the United States Patent and Trademark Office.

Authorized Signature /Reena Kuyper/                      Date June 16, 2010  
 Typed or printed name Reena Kuyper                      Registration No. 33,830

This collection of information is required by 37 CFR 1.311. The information is required to obtain or retain a benefit by the public which is to file (and by the USPTO to process) an application. Confidentiality is governed by 35 U.S.C. 122 and 37 CFR 1.14. This collection is estimated to take 12 minutes to complete, including gathering, preparing, and submitting the completed application form to the USPTO. Time will vary depending upon the individual case. Any comments on the amount of time you require to complete this form and/or suggestions for reducing this burden, should be sent to the Chief Information Officer, U.S. Patent and Trademark Office, U.S. Department of Commerce, P.O. Box 1450, Alexandria, Virginia 22313-1450. DO NOT SEND FEES OR COMPLETED FORMS TO THIS ADDRESS. SEND TO: Commissioner for Patents, P.O. Box 1450, Alexandria, Virginia 22313-1450.

Under the Paperwork Reduction Act of 1995, no persons are required to respond to a collection of information unless it displays a valid OMB control number.



## Electronic Patent Application Fee Transmittal

<b>Application Number:</b>	11948965				
<b>Filing Date:</b>	30-Nov-2007				
<b>Title of Invention:</b>	BRANCH CALLING AND CALLER ID BASED CALL ROUTING TELEPHONE FEATURES				
<b>First Named Inventor/Applicant Name:</b>	Samuel F. Wood				
<b>Filer:</b>	Reena Kuyper				
<b>Attorney Docket Number:</b>	TLM-103C1DIV				
Filed as Small Entity					
<b>Utility under 35 USC 111(a) Filing Fees</b>					
<b>Description</b>	<b>Fee Code</b>	<b>Quantity</b>	<b>Amount</b>	<b>Sub-Total in USD(\$)</b>	
<b>Basic Filing:</b>					
<b>Pages:</b>					
<b>Claims:</b>					
<b>Miscellaneous-Filing:</b>					
Publ. Fee- early, voluntary, or normal	1504	1	300	300	
<b>Petition:</b>					
<b>Patent-Appeals-and-Interference:</b>					
<b>Post-Allowance-and-Post-Issuance:</b>					
Utility Appl issue fee	2501	1	755	755	

Description	Fee Code	Quantity	Amount	Sub-Total in USD(\$)
<b>Extension-of-Time:</b>				
<b>Miscellaneous:</b>				
Printed copy of patent - no color	8001	6	3	18
<b>Total in USD (\$)</b>				<b>1073</b>

## Electronic Acknowledgement Receipt

<b>EFS ID:</b>	7831246
<b>Application Number:</b>	11948965
<b>International Application Number:</b>	
<b>Confirmation Number:</b>	3783
<b>Title of Invention:</b>	BRANCH CALLING AND CALLER ID BASED CALL ROUTING TELEPHONE FEATURES
<b>First Named Inventor/Applicant Name:</b>	Samuel F. Wood
<b>Customer Number:</b>	49637
<b>Filer:</b>	Reena Kuyper
<b>Filer Authorized By:</b>	
<b>Attorney Docket Number:</b>	TLM-103C1DIV
<b>Receipt Date:</b>	16-JUN-2010
<b>Filing Date:</b>	30-NOV-2007
<b>Time Stamp:</b>	22:45:37
<b>Application Type:</b>	Utility under 35 USC 111(a)

### Payment information:

Submitted with Payment	yes
Payment Type	Deposit Account
Payment was successfully received in RAM	\$1073
RAM confirmation Number	7923
Deposit Account	503102
Authorized User	

The Director of the USPTO is hereby authorized to charge indicated fees and credit any overpayment as follows:

Charge any Additional Fees required under 37 C.F.R. Section 1.16 (National application filing, search, and examination fees)

Charge any Additional Fees required under 37 C.F.R. Section 1.17 (Patent application and reexamination processing fees)

Charge any Additional Fees required under 37 C.F.R. Section 1.19 (Document supply fees)  
 Charge any Additional Fees required under 37 C.F.R. Section 1.20 (Post Issuance fees)  
 Charge any Additional Fees required under 37 C.F.R. Section 1.21 (Miscellaneous fees and charges)

**File Listing:**

Document Number	Document Description	File Name	File Size(Bytes)/ Message Digest	Multi Part /.zip	Pages (if appl.)
1	Issue Fee Payment (PTO-85B)	TLM-103C1DIV_Issue_Fee_Transmittal_6-16-10.pdf	221318 d10fd0e88a951eb5e4c9b0f3eee02cecd14d839a	no	1

**Warnings:**

**Information:**

2	Fee Worksheet (PTO-875)	fee-info.pdf	33627 03028b38fe97dfd407441b24bfae90e2e70fae81	no	2
---	-------------------------	--------------	---	----	---

**Warnings:**

**Information:**

**Total Files Size (in bytes):** 254945

This Acknowledgement Receipt evidences receipt on the noted date by the USPTO of the indicated documents, characterized by the applicant, and including page counts, where applicable. It serves as evidence of receipt similar to a Post Card, as described in MPEP 503.

**New Applications Under 35 U.S.C. 111**

If a new application is being filed and the application includes the necessary components for a filing date (see 37 CFR 1.53(b)-(d) and MPEP 506), a Filing Receipt (37 CFR 1.54) will be issued in due course and the date shown on this Acknowledgement Receipt will establish the filing date of the application.

**National Stage of an International Application under 35 U.S.C. 371**

If a timely submission to enter the national stage of an international application is compliant with the conditions of 35 U.S.C. 371 and other applicable requirements a Form PCT/DO/EO/903 indicating acceptance of the application as a national stage submission under 35 U.S.C. 371 will be issued in addition to the Filing Receipt, in due course.

**New International Application Filed with the USPTO as a Receiving Office**

If a new international application is being filed and the international application includes the necessary components for an international filing date (see PCT Article 11 and MPEP 1810), a Notification of the International Application Number and of the International Filing Date (Form PCT/RO/105) will be issued in due course, subject to prescriptions concerning national security, and the date shown on this Acknowledgement Receipt will establish the international filing date of the application.

<b>FORM PTO-1449</b>  <b>LIST OF PATENTS AND OTHER ITEMS FOR APPLICANT'S INFORMATION DISCLOSURE STATEMENT</b>  (Use several sheets if necessary)	<b>ATTY. DOCKET NO.</b> TLM-103C1DIV	<b>SERIAL NO.</b> 11/948,965
	<b>APPLICANT:</b> Samuel F. WOOD, et al.	
	<b>FILING DATE:</b> November 30, 2007	<b>GROUP:</b> 2614

U.S. PATENT DOCUMENTS							
EXAMINER INITIAL		DOCUMENT NUMBER	DATE	NAME	CLASS	SUB CLASS	FILING DATE
		2004/0240657 A1	12-02-2004	Camarillo	379	221.02	-----
		2004/0264673 A1	12-30-2004	Novack	379	221.11	-----
		5,469,500	11-21-1995	Satter et al.	379	201	-----
		6,327,258	12-04-2001	Deschaine et al.	370	356	-----
		6,643,282	11-04-2003	Christie	370	352	-----
		7,123,708	10-17-2006	Gavillet	379	219	-----
		7,242,759	07-10-2007	Sanchez et al.	379	219	-----
		7,436,851	10-14-2008	Chambers et al.	370	325	-----

FOREIGN PATENT DOCUMENTS							
EXAMINER INITIAL		DOCUMENT NUMBER	DATE	COUNTRY	CLASS	SUB CLASS	TRANSLATI YE NO

OTHER DOCUMENTS (Including Author, Title, Date, Pertinent Pages, etc.)		
EXAMINER INITIAL		

<b>EXAMINER:</b>	<b>DATE CONSIDERED:</b>
EXAMINER: Initial if reference is considered, whether or not citation is in conformance with MPEP 609; Draw line through citation if not in conformance and not considered. Include a copy of this form with next communication to applicant	

## Electronic Acknowledgement Receipt

<b>EFS ID:</b>	7764442
<b>Application Number:</b>	11948965
<b>International Application Number:</b>	
<b>Confirmation Number:</b>	3783
<b>Title of Invention:</b>	BRANCH CALLING AND CALLER ID BASED CALL ROUTING TELEPHONE FEATURES
<b>First Named Inventor/Applicant Name:</b>	Samuel F. Wood
<b>Customer Number:</b>	49637
<b>Filer:</b>	Reena Kuyper
<b>Filer Authorized By:</b>	
<b>Attorney Docket Number:</b>	TLM-103C1DIV
<b>Receipt Date:</b>	07-JUN-2010
<b>Filing Date:</b>	30-NOV-2007
<b>Time Stamp:</b>	22:36:54
<b>Application Type:</b>	Utility under 35 USC 111(a)

### Payment information:

Submitted with Payment	no
------------------------	----

### File Listing:

Document Number	Document Description	File Name	File Size(Bytes)/ Message Digest	Multi Part /.zip	Pages (if appl.)
1	Transmittal Letter	TLM-103C1DIV_IDS_placed_in_file_final_6-7-10.pdf	27494 <small>42ac8a6b84e55edf011bb461c68ae081dc6f c9b2</small>	no	3

### Warnings:

### Information:

2	Information Disclosure Statement (IDS) Filed (SB/08)	TLM-103C1DIV_PTO_1449_fina l_6-7-10.pdf	26013  b6aaf8fbcae905fc062c45327b721ce2610f2 747	no	1
---	---	--	---	----	---

**Warnings:**

**Information:**

This is not an USPTO supplied IDS fillable form

**Total Files Size (in bytes):**

53507

**This Acknowledgement Receipt evidences receipt on the noted date by the USPTO of the indicated documents, characterized by the applicant, and including page counts, where applicable. It serves as evidence of receipt similar to a Post Card, as described in MPEP 503.**

**New Applications Under 35 U.S.C. 111**

**If a new application is being filed and the application includes the necessary components for a filing date (see 37 CFR 1.53(b)-(d) and MPEP 506), a Filing Receipt (37 CFR 1.54) will be issued in due course and the date shown on this Acknowledgement Receipt will establish the filing date of the application.**

**National Stage of an International Application under 35 U.S.C. 371**

**If a timely submission to enter the national stage of an international application is compliant with the conditions of 35 U.S.C. 371 and other applicable requirements a Form PCT/DO/EO/903 indicating acceptance of the application as a national stage submission under 35 U.S.C. 371 will be issued in addition to the Filing Receipt, in due course.**

**New International Application Filed with the USPTO as a Receiving Office**

**If a new international application is being filed and the international application includes the necessary components for an international filing date (see PCT Article 11 and MPEP 1810), a Notification of the International Application Number and of the International Filing Date (Form PCT/RO/105) will be issued in due course, subject to prescriptions concerning national security, and the date shown on this Acknowledgement Receipt will establish the international filing date of the application.**

**IN THE UNITED STATES PATENT AND TRADEMARK OFFICE**

<b>In re the Application of:</b>	)	<b>Customer No.:</b>	49,637
	)		
Samuel F. WOOD, et al.	)	<b>Confirmation No.:</b>	3783
	)		
<b>Serial No.:</b> 11/948,965	)	<b>Group Art Unit:</b>	2614
	)		
<b>Filed:</b> June 7, 2006	)	<b>Examiner:</b>	Creighton H. Smith
	)		
<b>For:</b> BRANCH CALLING AND CALLER ID	)	<b>Docket No.:</b>	TLM-103.C1DIV
BASED CALL ROUTING TELEPHONE	)		
FEATURES	)		
	)		

---

**SUPPLEMENTAL INFORMATION DISCLOSURE STATEMENT**  
**UNDER 37 C.F.R. 1.97(i)**

Commissioner for Patents  
P.O. Box 1450  
Alexandria, VA 22313-1450

Sir:

In compliance with the duty of disclosure under 37 CFR § 1.56, 37 CFR §§ 1.97, and 1.98, after receiving the Notice of Allowance, Applicants recently became aware of the following documents, none of which are relevant to the claims allowed. Nevertheless, Applicants request that these documents should be placed in the file wrapper in accordance with 37 C.F.R. 1.97(i) for future access by others. These documents are listed in the attached forms PTO-1449. These documents are also cited in related pending application serial numbers 11/428,822 and 11/428,825. Applicants indicate below a brief description of each reference. The references pertain to fundamental call routing architecture and operations executed within a single carrier network as opposed to the Applicants' inventions, which are directed to architecture and operations that apply call features to the fundamental call routing operations over multiple carrier networks.



Application No.: 11/948,965

1. U.S. Patent No. 5,469,500 describes a method and apparatus for delivering calling services by contemplating an AIN (Advanced Intelligent Network) architecture, different from the existing network structure, with software upgrades to this AIN to implement calling services.
2. Publication No. 2004/0264673 A1 describes an architecture to connect disparate peripherals in a network, not to execute features as in Applicants' inventions. In addition, it should be noted that this publication is dated December 30, 2004, after the effective filing date of this application, which is May 4, 2000. The filing date is June 30, 2003.
3. Publication No. 2004/0240657 A1 describes an architecture for routing schemes in the network to route calls to different tandems in the network. This publication is dated December 2, 2004, after the effective filing date of this application, which is May 4, 2000. The filing date is May 28, 2003.
4. U.S. Patent No. 7,436,851 describes using ATM (Asynchronous Transfer Mode) and other transmission facilities for routing within IP or PSTN networks. There is no disclosure of any calling features.
5. U.S. Patent No. 7,123,708 describes an architecture for IP routing of calls (by connecting different networks and carriers) within the internet. It does not describe applying any features to call routing operations of the network. This patent issued on October 14, 2008, and has a filing date of March 29, 1999.
6. U.S. Patent No. 7,242,759 describes an architecture for routing of calls in the network specifically to 800 numbers. The patent issued on October 14, 2008 and has a filing date of March 29, 1999.
7. U.S. Patent No. 6,643,282 describes a major network architecture proposed by Sprint Communications Company LP. There is no disclosure of applying features.

Application No.: 11/948,965

8. U.S. Patent No. 6,327,258 describes an architecture and operations for connecting the PSTN (Public Switched Telephone Network) with Internet data networks utilizing ATM. The architecture is for routing calls in a single network.

Applicants submit that the claims, as allowed, are distinct from the teachings in these references. Applicants also believe that there are no fees in connection with this submission; however, in the event the U.S. Patent Office determines that fees are necessary, please charge them to Berry & Associates P.C.'s Deposit Account No. **50-3102**.

Respectfully submitted,  
BERRY & ASSOCIATES P.C.

Dated: June 7, 2010

By:           /Reena Kuyper/            
Reena Kuyper  
Registration No. 33,830

9229 Sunset Blvd., Suite 630  
Los Angeles, California 90069  
(310) 247-2860  
*Customer No. 49,637*

Under the Paperwork Reduction Act of 1995, no persons are required to respond to a collection of information unless it contains a valid OMB control number.

<b>INFORMATION DISCLOSURE STATEMENT BY APPLICANT</b> ( Not for submission under 37 CFR 1.99)	Application Number		
	Filing Date		2007-11-30
	First Named Inventor	Samuel F. Wood	
	Art Unit	TBD	
	Examiner Name	Not yet assigned	
	Attorney Docket Number	TEL-M-8801-1P-1D	

U.S. PATENTS							Remove
Examiner Initial*	Cite No	Patent Number	Kind Code <sup>1</sup>	Issue Date	Name of Patentee or Applicant of cited Document	Page:, Columns, Lines where Relevant Passages or Relevant Figures Appear	
	1	5958016		1999-09-28	Chang et al.		
	2	5974449		1999-10-26	Chang et al.		
<i>ES</i>	3	59533892		1999-09-14	Rhie et al.		
<i>5/11/10</i>	4	6012088		2000-01-04	Li et al.		
	5	6031836		2000-02-29	Haserodt		
	6	5566236		1996-10-15	MeLampy et al.		
	7	5982866		1999-11-09	Kowalski, Thaddeus Julius		
	8	6359892		2002-03-19	Szlam, Aleksander		

**INFORMATION DISCLOSURE  
STATEMENT BY APPLICANT**  
( Not for submission under 37 CFR 1.99)

Application Number		
Filing Date		2007-11-30
First Named Inventor	Samuel F. Wood	
Art Unit	TBD	
Examiner Name	Not yet assigned	
Attorney Docket Number	TEL-M-8801-1P-1D	

9	5878113		1999-03-02	Bhusri, Gurcharan S.
10	6956941	B1	2005-10-18	Duncan et al.
11	6788775	B1	2004-09-07	Simpson, Anita Hogans
12	6697461	B1	2004-02-24	Middleswarth et al.
13	6459780	B1	2002-10-01	Wurster et al.
14	6359892	B1	2002-03-19	Szlam

If you wish to add additional U.S. Patent citation information please click the Add button.

Add

**U.S.PATENT APPLICATION PUBLICATIONS**

Remove

Examiner Initial*	Cite No	Publication Number	Kind Code <sup>1</sup>	Publication Date	Name of Patentee or Applicant of cited Document	Pages, Columns, Lines where Relevant Passages or Relevant Figures Appear
ES 5/11/10	1	20030026403	A1	02/06/2003 <del>2007-11-30</del>	Clapper, Edward O.	
	2	20030156693	A1	2003-08-21	Goldman, Philip Y.	
	3	20030133553	A1	2003-07-17	Khakoo et al.	



Under the Paperwork Reduction Act of 1995, no persons are required to respond to a collection of information unless it contains a valid OMB control number.

<b>INFORMATION DISCLOSURE STATEMENT BY APPLICANT</b> ( Not for submission under 37 CFR 1.99)	Application Number		
	Filing Date		2007-11-30
	First Named Inventor	Samuel F. Wood	
	Art Unit	TBD	
	Examiner Name	Not yet assigned	
	Attorney Docket Number	TEL-M-8801-1P-1D	

U.S. PATENTS							Remove
Examiner Initial*	Cite No	Patent Number	Kind Code <sup>1</sup>	Issue Date	Name of Patentee or Applicant of cited Document	Pages, Columns, Lines where Relevant Passages or Relevant Figures Appear	
	1	5958016		1999-09-28	Chang et al.		
	2	5974449		1999-10-26	Chang et al.		
<i>ES</i>	3	59533392		1999-09-14	Rhie et al.		
<i>5/7/10</i>	4	6012088		2000-01-04	Li et al.		
	5	6031836		2000-02-29	Haserodt		
	6	5566236		1996-10-15	McLampy et al.		
	7	5982866		1999-11-09	Kowalski, Thaddeus Julius		
	8	6359892		2002-03-19	Szlam, Aleksander		





UNITED STATES PATENT AND TRADEMARK OFFICE

UNITED STATES DEPARTMENT OF COMMERCE
United States Patent and Trademark Office
Address: COMMISSIONER FOR PATENTS
P.O. Box 1450
Alexandria, Virginia 22313-1450
www.uspto.gov

NOTICE OF ALLOWANCE AND FEE(S) DUE

49637 7590 03/19/2010

BERRY & ASSOCIATES P.C.
9229 SUNSET BOULEVARD
SUITE 630
LOS ANGELES, CA 90069

EXAMINER

SMITH, CREIGHTON H

ART UNIT PAPER NUMBER

2614

DATE MAILED: 03/19/2010

Table with 5 columns: APPLICATION NO., FILING DATE, FIRST NAMED INVENTOR, ATTORNEY DOCKET NO., CONFIRMATION NO.

11/948,965 11/30/2007 Samuel F. Wood TLM-103CIDIV 3783

TITLE OF INVENTION: BRANCH CALLING AND CALLER ID BASED CALL ROUTING TELEPHONE FEATURES

Table with 7 columns: APPLN. TYPE, SMALL ENTITY, ISSUE FEE DUE, PUBLICATION FEE DUE, PREV. PAID ISSUE FEE, TOTAL FEE(S) DUE, DATE DUE

nonprovisional YES \$755 \$300 \$0 \$1055 06/21/2010

THE APPLICATION IDENTIFIED ABOVE HAS BEEN EXAMINED AND IS ALLOWED FOR ISSUANCE AS A PATENT. PROSECUTION ON THE MERITS IS CLOSED. THIS NOTICE OF ALLOWANCE IS NOT A GRANT OF PATENT RIGHTS. THIS APPLICATION IS SUBJECT TO WITHDRAWAL FROM ISSUE AT THE INITIATIVE OF THE OFFICE OR UPON PETITION BY THE APPLICANT. SEE 37 CFR 1.313 AND MPEP 1308.

THE ISSUE FEE AND PUBLICATION FEE (IF REQUIRED) MUST BE PAID WITHIN THREE MONTHS FROM THE MAILING DATE OF THIS NOTICE OR THIS APPLICATION SHALL BE REGARDED AS ABANDONED. THIS STATUTORY PERIOD CANNOT BE EXTENDED. SEE 35 U.S.C. 151. THE ISSUE FEE DUE INDICATED ABOVE DOES NOT REFLECT A CREDIT FOR ANY PREVIOUSLY PAID ISSUE FEE IN THIS APPLICATION. IF AN ISSUE FEE HAS PREVIOUSLY BEEN PAID IN THIS APPLICATION (AS SHOWN ABOVE), THE RETURN OF PART B OF THIS FORM WILL BE CONSIDERED A REQUEST TO REAPPLY THE PREVIOUSLY PAID ISSUE FEE TOWARD THE ISSUE FEE NOW DUE.

HOW TO REPLY TO THIS NOTICE:

I. Review the SMALL ENTITY status shown above.

If the SMALL ENTITY is shown as YES, verify your current SMALL ENTITY status:

- A. If the status is the same, pay the TOTAL FEE(S) DUE shown above.
B. If the status above is to be removed, check box 5b on Part B - Fee(s) Transmittal and pay the PUBLICATION FEE (if required) and twice the amount of the ISSUE FEE shown above, or

If the SMALL ENTITY is shown as NO:

- A. Pay TOTAL FEE(S) DUE shown above, or
B. If applicant claimed SMALL ENTITY status before, or is now claiming SMALL ENTITY status, check box 5a on Part B - Fee(s) Transmittal and pay the PUBLICATION FEE (if required) and 1/2 the ISSUE FEE shown above.

II. PART B - FEE(S) TRANSMITTAL, or its equivalent, must be completed and returned to the United States Patent and Trademark Office (USPTO) with your ISSUE FEE and PUBLICATION FEE (if required). If you are charging the fee(s) to your deposit account, section "4b" of Part B - Fee(s) Transmittal should be completed and an extra copy of the form should be submitted. If an equivalent of Part B is filed, a request to reapply a previously paid issue fee must be clearly made, and delays in processing may occur due to the difficulty in recognizing the paper as an equivalent of Part B.

III. All communications regarding this application must give the application number. Please direct all communications prior to issuance to Mail Stop ISSUE FEE unless advised to the contrary.

IMPORTANT REMINDER: Utility patents issuing on applications filed on or after Dec. 12, 1980 may require payment of maintenance fees. It is patentee's responsibility to ensure timely payment of maintenance fees when due.



**PART B - FEE(S) TRANSMITTAL**

**Complete and send this form, together with applicable fee(s), to: Mail Mail Stop ISSUE FEE  
 Commissioner for Patents  
 P.O. Box 1450  
 Alexandria, Virginia 22313-1450  
 or Fax (571)-273-2885**

**INSTRUCTIONS:** This form should be used for transmitting the ISSUE FEE and PUBLICATION FEE (if required). Blocks 1 through 5 should be completed where appropriate. All further correspondence including the Patent, advance orders and notification of maintenance fees will be mailed to the current correspondence address as indicated unless corrected below or directed otherwise in Block 1, by (a) specifying a new correspondence address; and/or (b) indicating a separate "FEE ADDRESS" for maintenance fee notifications.

CURRENT CORRESPONDENCE ADDRESS (Note: Use Block 1 for any change of address)

49637                      7590                      03/19/2010

**BERRY & ASSOCIATES P.C.**  
 9229 SUNSET BOULEVARD  
 SUITE 630  
 LOS ANGELES, CA 90069

Note: A certificate of mailing can only be used for domestic mailings of the Fee(s) Transmittal. This certificate cannot be used for any other accompanying papers. Each additional paper, such as an assignment or formal drawing, must have its own certificate of mailing or transmission.

**Certificate of Mailing or Transmission**

I hereby certify that this Fee(s) Transmittal is being deposited with the United States Postal Service with sufficient postage for first class mail in an envelope addressed to the Mail Stop ISSUE FEE address above, or being facsimile transmitted to the USPTO (571) 273-2885, on the date indicated below.

(Depositor's name)
(Signature)
(Date)

APPLICATION NO.	FILING DATE	FIRST NAMED INVENTOR	ATTORNEY DOCKET NO.	CONFIRMATION NO.
11/948,965	11/30/2007	Samuel F. Wood	TLM-103C1DIV	3783

TITLE OF INVENTION: BRANCH CALLING AND CALLER ID BASED CALL ROUTING TELEPHONE FEATURES

APPLN. TYPE	SMALL ENTITY	ISSUE FEE DUE	PUBLICATION FEE DUE	PREV. PAID ISSUE FEE	TOTAL FEE(S) DUE	DATE DUE
nonprovisional	YES	\$755	\$300	\$0	\$1055	06/21/2010

EXAMINER	ART UNIT	CLASS-SUBCLASS
SMITH, CREIGHTON H	2614	379-142020

<p>1. Change of correspondence address or indication of "Fee Address" (37 CFR 1.363).</p> <p><input type="checkbox"/> Change of correspondence address (or Change of Correspondence Address form PTO/SB/122) attached.</p> <p><input type="checkbox"/> "Fee Address" indication (or "Fee Address" Indication form PTO/SB/47; Rev 03-02 or more recent) attached. <b>Use of a Customer Number is required.</b></p>	<p>2. For printing on the patent front page, list</p> <p>(1) the names of up to 3 registered patent attorneys or agents OR, alternatively, _____ 1</p> <p>(2) the name of a single firm (having as a member a registered attorney or agent) and the names of up to 2 registered patent attorneys or agents. If no name is listed, no name will be printed. _____ 2</p> <p>_____ 3</p>
---	---

3. ASSIGNEE NAME AND RESIDENCE DATA TO BE PRINTED ON THE PATENT (print or type)

PLEASE NOTE: Unless an assignee is identified below, no assignee data will appear on the patent. If an assignee is identified below, the document has been filed for recordation as set forth in 37 CFR 3.111. Completion of this form is NOT a substitute for filing an assignment.

(A) NAME OF ASSIGNEE \_\_\_\_\_ (B) RESIDENCE: (CITY and STATE OR COUNTRY) \_\_\_\_\_

Please check the appropriate assignee category or categories (will not be printed on the patent):  Individual  Corporation or other private group entity  Government

<p>4a. The following fee(s) are submitted:</p> <p><input type="checkbox"/> Issue Fee</p> <p><input type="checkbox"/> Publication Fee (No small entity discount permitted)</p> <p><input type="checkbox"/> Advance Order - # of Copies _____</p>	<p>4b. Payment of Fee(s): (Please first reapply any previously paid issue fee shown above)</p> <p><input type="checkbox"/> A check is enclosed.</p> <p><input type="checkbox"/> Payment by credit card. Form PTO-2038 is attached.</p> <p><input type="checkbox"/> The Director is hereby authorized to charge the required fee(s), any deficiency, or credit any overpayment, to Deposit Account Number _____ (enclose an extra copy of this form).</p>
---	--

5. **Change in Entity Status** (from status indicated above)

a. Applicant claims SMALL ENTITY status. See 37 CFR 1.27.  b. Applicant is no longer claiming SMALL ENTITY status. See 37 CFR 1.27(g)(2).

NOTE: The Issue Fee and Publication Fee (if required) will not be accepted from anyone other than the applicant; a registered attorney or agent; or the assignee or other party in interest as shown by the records of the United States Patent and Trademark Office.

Authorized Signature \_\_\_\_\_ Date \_\_\_\_\_

Typed or printed name \_\_\_\_\_ Registration No. \_\_\_\_\_

This collection of information is required by 37 CFR 1.311. The information is required to obtain or retain a benefit by the public which is to file (and by the USPTO to process) an application. Confidentiality is governed by 35 U.S.C. 122 and 37 CFR 1.14. This collection is estimated to take 12 minutes to complete, including gathering, preparing, and submitting the completed application form to the USPTO. Time will vary depending upon the individual case. Any comments on the amount of time you require to complete this form and/or suggestions for reducing this burden, should be sent to the Chief Information Officer, U.S. Patent and Trademark Office, U.S. Department of Commerce, P.O. Box 1450, Alexandria, Virginia 22313-1450. DO NOT SEND FEES OR COMPLETED FORMS TO THIS ADDRESS. SEND TO: Commissioner for Patents, P.O. Box 1450, Alexandria, Virginia 22313-1450.

Under the Paperwork Reduction Act of 1995, no persons are required to respond to a collection of information unless it displays a valid OMB control number.



UNITED STATES PATENT AND TRADEMARK OFFICE

UNITED STATES DEPARTMENT OF COMMERCE
United States Patent and Trademark Office
Address: COMMISSIONER FOR PATENTS
P.O. Box 1450
Alexandria, Virginia 22313-1450
www.uspto.gov

Table with 5 columns: APPLICATION NO., FILING DATE, FIRST NAMED INVENTOR, ATTORNEY DOCKET NO., CONFIRMATION NO.
Row 1: 11/948,965, 11/30/2007, Samuel F. Wood, TLM-103C1DIV, 3783
Row 2: 49637, 7590, 03/19/2010, [Empty], [Empty]
Text: BERRY & ASSOCIATES P.C., 9229 SUNSET BOULEVARD, SUITE 630, LOS ANGELES, CA 90069
Text: EXAMINER SMITH, CREIGHTON H
Text: ART UNIT 2614, PAPER NUMBER [Empty]
Text: DATE MAILED: 03/19/2010

Determination of Patent Term Adjustment under 35 U.S.C. 154 (b)
(application filed on or after May 29, 2000)

The Patent Term Adjustment to date is 0 day(s). If the issue fee is paid on the date that is three months after the mailing date of this notice and the patent issues on the Tuesday before the date that is 28 weeks (six and a half months) after the mailing date of this notice, the Patent Term Adjustment will be 0 day(s).

If a Continued Prosecution Application (CPA) was filed in the above-identified application, the filing date that determines Patent Term Adjustment is the filing date of the most recent CPA.

Applicant will be able to obtain more detailed information by accessing the Patent Application Information Retrieval (PAIR) WEB site (http://pair.uspto.gov).

Any questions regarding the Patent Term Extension or Adjustment determination should be directed to the Office of Patent Legal Administration at (571)-272-7702. Questions relating to issue and publication fee payments should be directed to the Customer Service Center of the Office of Patent Publication at 1-(888)-786-0101 or (571)-272-4200.

<b>Notice of Allowability</b>	<b>Application No.</b>	<b>Applicant(s)</b>	
	11/948,965	WOOD ET AL.	
	<b>Examiner</b>	<b>Art Unit</b>	
	CREIGHTON SMITH	2614	

**-- The MAILING DATE of this communication appears on the cover sheet with the correspondence address--**

All claims being allowable, PROSECUTION ON THE MERITS IS (OR REMAINS) CLOSED in this application. If not included herewith (or previously mailed), a Notice of Allowance (PTOL-85) or other appropriate communication will be mailed in due course. **THIS NOTICE OF ALLOWABILITY IS NOT A GRANT OF PATENT RIGHTS.** This application is subject to withdrawal from issue at the initiative of the Office or upon petition by the applicant. See 37 CFR 1.313 and MPEP 1308.

1.  This communication is responsive to rcv filed on 22 FEB '10.
2.  The allowed claim(s) is/are 1,3-7,10 and 12-50.
3.  Acknowledgment is made of a claim for foreign priority under 35 U.S.C. § 119(a)-(d) or (f).
  - a)  All    b)  Some\*    c)  None    of the:
    1.  Certified copies of the priority documents have been received.
    2.  Certified copies of the priority documents have been received in Application No. \_\_\_\_\_.
    3.  Copies of the certified copies of the priority documents have been received in this national stage application from the International Bureau (PCT Rule 17.2(a)).

\* Certified copies not received: \_\_\_\_\_.

Applicant has THREE MONTHS FROM THE "MAILING DATE" of this communication to file a reply complying with the requirements noted below. Failure to timely comply will result in ABANDONMENT of this application.  
**THIS THREE-MONTH PERIOD IS NOT EXTENDABLE.**

4.  A SUBSTITUTE OATH OR DECLARATION must be submitted. Note the attached EXAMINER'S AMENDMENT or NOTICE OF INFORMAL PATENT APPLICATION (PTO-152) which gives reason(s) why the oath or declaration is deficient.
5.  CORRECTED DRAWINGS ( as "replacement sheets") must be submitted.
  - (a)  including changes required by the Notice of Draftsperson's Patent Drawing Review ( PTO-948) attached
    - 1)  hereto or 2)  to Paper No./Mail Date \_\_\_\_\_.
  - (b)  including changes required by the attached Examiner's Amendment / Comment or in the Office action of Paper No./Mail Date \_\_\_\_\_.

**Identifying indicia such as the application number (see 37 CFR 1.84(c)) should be written on the drawings in the front (not the back) of each sheet. Replacement sheet(s) should be labeled as such in the header according to 37 CFR 1.121(d).**
6.  DEPOSIT OF and/or INFORMATION about the deposit of BIOLOGICAL MATERIAL must be submitted. Note the attached Examiner's comment regarding REQUIREMENT FOR THE DEPOSIT OF BIOLOGICAL MATERIAL.

**Attachment(s)**

- |  |  |
|--|--|
| <ol style="list-style-type: none"> <li>1. <input type="checkbox"/> Notice of References Cited (PTO-892)</li> <li>2. <input type="checkbox"/> Notice of Draftsperson's Patent Drawing Review (PTO-948)</li> <li>3. <input checked="" type="checkbox"/> Information Disclosure Statements (PTO/SB/08),<br/>Paper No./Mail Date <u>02.17.2010</u></li> <li>4. <input type="checkbox"/> Examiner's Comment Regarding Requirement for Deposit of Biological Material</li> </ol> | <ol style="list-style-type: none"> <li>5. <input type="checkbox"/> Notice of Informal Patent Application</li> <li>6. <input type="checkbox"/> Interview Summary (PTO-413),<br/>Paper No./Mail Date _____.</li> <li>7. <input type="checkbox"/> Examiner's Amendment/Comment</li> <li>8. <input checked="" type="checkbox"/> Examiner's Statement of Reasons for Allowance</li> <li>9. <input type="checkbox"/> Other _____.</li> </ol> |
|--|--|

--	--

### REASONS FOR ALLOWANCE

The following is an examiner's statement of reasons for allowance: The prior art fails to disclose edge switches for local and other switching facilities; a controlling apparatus that will receive a 1<sup>st</sup> call and then initiating a 2<sup>nd</sup> call in accordance with control criteria entered by a specified user thru the Internet, and then the controlling device coupling the 1<sup>st</sup> and 2<sup>nd</sup> calls together. No obvious combination of references would have taught one of ordinary skill in the art to make and use applicant's method as claimed.

Any comments considered necessary by applicant must be submitted no later than the payment of the issue fee and, to avoid processing delays, should preferably accompany the issue fee. Such submissions should be clearly labeled "Comments on Statement of Reasons for Allowance."

Any inquiry concerning this communication or earlier communications from the examiner should be directed to CREIGHTON SMITH whose telephone number is (571)272-7546. The examiner can normally be reached on 5-4-9.

If attempts to reach the examiner by telephone are unsuccessful, the examiner's supervisor, Curt Kuntz can be reached on 27499. The fax phone number for the organization where this application or proceeding is assigned is 571-273-8300.

Application/Control Number: 11/948,965  
Art Unit: 2614


Page 3

Information regarding the status of an application may be obtained from the Patent Application Information Retrieval (PAIR) system. Status information for published applications may be obtained from either Private PAIR or Public PAIR. Status information for unpublished applications is available through Private PAIR only. For more information about the PAIR system, see <http://pair-direct.uspto.gov>. Should you have questions on access to the Private PAIR system, contact the Electronic Business Center (EBC) at 866-217-9197 (toll-free). If you would like assistance from a USPTO Customer Service Representative or access to the automated information system, call 800-786-9199 (IN USA OR CANADA) or 571-272-1000.

/CREIGHTON SMITH/  
Primary Examiner, Art Unit 2614

15 MAR '10


\*\*\*

<b>Index of Claims</b> 	<b>Application/Control No.</b> 11948965	<b>Applicant(s)/Patent Under Reexamination</b> WOOD ET AL.
	<b>Examiner</b> CREIGHTON SMITH	<b>Art Unit</b> 2614

✓	<b>Rejected</b>	-	<b>Cancelled</b>	N	<b>Non-Elected</b>	A	<b>Appeal</b>
=	<b>Allowed</b>	÷	<b>Restricted</b>	I	<b>Interference</b>	O	<b>Objected</b>

Claims renumbered in the same order as presented by applicant
  CPA
  T.D.
  R.1.47

CLAIM		DATE							
Final	Original	03/05/2009	10/08/2009	03/15/2010					
1	1	✓	✓	=					
	2	✓	-	-					
2	3	✓	✓	=					
3	4	✓	✓	=					
4	5	✓	✓	=					
5	6	✓	✓	=					
6	7	✓	✓	=					
	8	✓	-	-					
	9	✓	-	-					
7	10	✓	✓	=					
	11	✓	-	-					
8	12	✓	✓	=					
9	13	✓	✓	=					
10	14	✓	✓	=					
11	15	✓	✓	=					
12	16	✓	✓	=					
13	17	✓	✓	=					
14	18		✓	=					
15	19		✓	=					
16	20		✓	=					
17	21		✓	=					
18	22			=					
19	23			=					
20	24			=					
21	25			=					
22	26			=					
23	27			=					
24	28			=					
25	29			=					
26	30			=					
27	31			=					
28	32			=					
29	33			=					
30	34			=					
31	35			=					
32	36			=					

<b><i>Index of Claims</i></b>  	<b>Application/Control No.</b>  11948965	<b>Applicant(s)/Patent Under Reexamination</b>  WOOD ET AL.
	<b>Examiner</b>  CREIGHTON SMITH	<b>Art Unit</b>  2614

✓	<b>Rejected</b>
=	<b>Allowed</b>

-	<b>Cancelled</b>
÷	<b>Restricted</b>

N	<b>Non-Elected</b>
I	<b>Interference</b>

A	<b>Appeal</b>
O	<b>Objected</b>

Claims renumbered in the same order as presented by applicant
  CPA
  T.D.
  R.1.47

CLAIM		DATE							
Final	Original	03/05/2009	10/08/2009	03/15/2010					
33	37			=					
34	38			=					
35	39			=					
36	40			=					
37	41			=					
38	42			=					
39	43			=					
40	44			=					
41	45			=					
42	46			=					
43	47			=					
44	48			=					
45	49			=					
46	50			=					





<b>Search Notes</b>  	<b>Application/Control No.</b>  11948965	<b>Applicant(s)/Patent Under Reexamination</b>  WOOD ET AL.
	<b>Examiner</b>  CREIGHTON SMITH	<b>Art Unit</b>  2614

<b>SEARCHED</b>			
<b>Class</b>	<b>Subclass</b>	<b>Date</b>	<b>Examiner</b>
379	211.04	05 MAR '09	chs
379	220.01, 221.02, 201.01,	15 MAR '10	chs

<b>SEARCH NOTES</b>		
<b>Search Notes</b>	<b>Date</b>	<b>Examiner</b>
EAST	05 MAR '09	chs
EAST	08 OCT '09	chs
EAST	15 MAR '10	chs

<b>INTERFERENCE SEARCH</b>			
<b>Class</b>	<b>Subclass</b>	<b>Date</b>	<b>Examiner</b>
EAST		15 MAR '10	chs

--	--

**EAST Search History**

**EAST Search History (Prior Art)**

Ref #	Hits	Search Query	DBs	Default Operator	Plurals	Time Stamp
L1	50	(@ad<="20000504") and controller with tandem near4 switch	US-PGPUB; USPAT; EPO; JPO	OR	OFF	2010/03/15 14:00
L2	11	(@ad<="20000504") and controller with tandem adj switch	US-PGPUB; USPAT; EPO; JPO	OR	OFF	2010/03/15 14:01
L3	3	(@ad<="20000504") and tandem adj access adj controller	US-PGPUB; USPAT; EPO; JPO	OR	OFF	2010/03/15 14:01
L4	11	(@ad<="20000504") and controller with tandem adj switch	US-PGPUB; USPAT; EPO; JPO	OR	OFF	2010/03/15 14:02
L5	50	(@ad<="20000504") and controller with tandem near4 switch	US-PGPUB; USPAT; EPO; JPO	OR	OFF	2010/03/15 14:12
L6	6275	(@ad<="20000504") and (process\$3 or control\$3) with (edge near5 switch\$2 or central near5 office\$1)	US-PGPUB; USPAT; EPO; JPO	OR	OFF	2010/03/15 15:20
L7	27	6 and ((second or another or other) near4 call with (control \$4 or process\$3) with first with second with calls with (control\$4 or process\$3))	US-PGPUB; USPAT; EPO; JPO	OR	OFF	2010/03/15 15:26

**EAST Search History (Interference)**

<This search history is empty>

**3/ 15/ 2010 3:46:45 PM**

**C:\ Documents and Settings\ Csmith1\ My Documents\ EAST\ Workspaces\ 11-393977.wsp**

<b>FORM PTO-1449</b>  <b>LIST OF PATENTS AND OTHER ITEMS FOR APPLICANT'S INFORMATION DISCLOSURE STATEMENT</b>  (Use several sheets if necessary)	<b>ATTY. DOCKET NO.</b> TLM-103C1DIV	<b>SERIAL NO.</b> 11/948,965
	<b>APPLICANT:</b> Samuel F. WOOD, et al.	
	<b>FILING DATE:</b> November 30, 2007	<b>GROUP:</b> 2614

U.S. PATENT DOCUMENTS							
EXAMINER INITIAL		DOCUMENT NUMBER	DATE	NAME	CLASS	SUB CLASS	FILING DATE
		2001/0022784	09-2001	Menon et al.	-----	-----	-----
		2001/0030950	10-2001	Chen et al.	-----	-----	-----
		4,313,035	01-1982	Jordan et al.	-----	-----	-----
		4,348,554	09-1982	Asmuth	-----	-----	-----
		4,611,094	09-1986	Asmuth et al.	-----	-----	-----
		4,611,096	09-1986	Asmuth et al.	-----	-----	-----
		4,953,198	08-1990	Daly et al.	-----	-----	-----
		4,973,837	11-1990	Bradbeer	-----	-----	-----
		5,297,191	03-1994	Gerszberg	-----	-----	-----
		5,311,582	05-1994	Davenport et al.	-----	-----	-----
		5,428,663	06-1995	Grimes et al.	-----	-----	-----
		5,448,623	09-1995	Wiedeman et al.	-----	-----	-----
		5,455,853	10-1995	Cebulka et al.	-----	-----	-----
		5,471,616	11-1995	Johnson et al.	-----	-----	-----
		5,495,567	02-1996	Iizawa et al.	-----	-----	-----
		5,497,339	03-1996	Bernard	-----	-----	-----
		5,557,658	09-1996	Gregorek et al.	-----	-----	-----
		5,563,937	10-1996	Bruno et al.	-----	-----	-----
		5,606,594	02-1997	Register et al.	-----	-----	-----
		5,628,004	051997	Gormley et al.	-----	-----	-----
		5,646,945	07-1997	Bergler	-----	-----	-----
		5,727,057	03-1998	Emery et al.	-----	-----	-----

<b>EXAMINER:</b> /Creighton Smith/	<b>DATE CONSIDERED:</b> 03/15/2010
EXAMINER: Initial if reference is considered, whether or not citation is in conformance with MPEP 609; Draw line through citation if not in conformance and not considered. Include a copy of this form with next communication to applicant	

<b>FORM PTO-1449</b>  <b>LIST OF PATENTS AND OTHER ITEMS FOR APPLICANT'S INFORMATION DISCLOSURE STATEMENT</b>  <b>(Use several sheets if necessary)</b>	<b>ATTY. DOCKET NO.</b> TLM-103C1DIV	<b>SERIAL NO.</b> 11/948,965
	<b>APPLICANT:</b> Samuel F. WOOD, et al.	
	<b>FILING DATE:</b> November 30, 2007	<b>GROUP:</b> 2614

U.S. PATENT DOCUMENTS							
EXAMINER INITIAL		DOCUMENT NUMBER	DATE	NAME	CLASS	SUB CLASS	FILING DATE
		5,727,057	03-1998	Emery et al.	-----	-----	-----
		5,732,074	03-1998	Spaur et al.	-----	-----	-----
		5,732,216	03-1998	Logan et al.	-----	-----	-----
		5,737,533	04-1998	De Hond	-----	-----	-----
		5,742,905	04-1998	Pepe et al.	-----	-----	-----
		5,806,057	09-1998	Gormley et al.	-----	-----	-----
		5,838,665	11-1998	Kahn et al.	-----	-----	-----
		5,850,433	12-1998	Rondeau	-----	-----	-----
		5,859,972	01-1999	Subramaniam et al.	-----	-----	-----
		5,875,405	02-1999	Honda	-----	-----	-----
		5,878,418	03-1999	Polcyn et al.	-----	-----	-----
		5,894,473	04-1999	Dent	-----	-----	-----
		5,894,595	04-1999	Foladare et al.	-----	-----	-----
		5,913,029	06-1999	Shostak	-----	-----	-----
		5,915,008	06-1999	Dulman	-----	-----	-----
		5,918,172	06-1999	Saunders et al.	-----	-----	-----
		5,930,700	07-1999	Pepper et al.	-----	-----	-----
		5,933,778	08-1999	Buhrmann et al.	-----	-----	-----
		5,938,757	08-1999	Bertsch	-----	-----	-----
		5,960,340	09-1999	Fuentes	-----	-----	-----
		5,970,059	10-1999	Ahopelto et al.	-----	-----	-----
		5,991,394	11-1999	Dezonno et al.	-----	-----	-----

<b>EXAMINER:</b> /Creighton Smith/	<b>DATE CONSIDERED:</b> 03/15/2010
EXAMINER: Initial if reference is considered, whether or not citation is in conformance with MPEP 609; Draw line through citation if not in conformance and not considered. Include a copy of this form with next communication to applicant	

<b>FORM PTO-1449</b>  <b>LIST OF PATENTS AND OTHER ITEMS FOR APPLICANT'S INFORMATION DISCLOSURE STATEMENT</b>  (Use several sheets if necessary)	<b>ATTY. DOCKET NO.</b> TLM-103C1DIV	<b>SERIAL NO.</b> 11/948,965
	<b>APPLICANT:</b> Samuel F. WOOD, et al.	
	<b>FILING DATE:</b> November 30, 2007	<b>GROUP:</b> 2614

U.S. PATENT DOCUMENTS							
EXAMINER INITIAL		DOCUMENT NUMBER	DATE	NAME	CLASS	SUB CLASS	FILING DATE
		6,006,272	12-1999	Aravamudan et al.	-----	-----	-----
		6,014,437	01-2000	Acker et al.	-----	-----	-----
		6,020,916	02-2000	Gerszberg et al.	-----	-----	-----
		6,028,917	02-2000	Creamer et al.	-----	-----	-----
		6,031,904	02-2000	An et al.	-----	-----	-----
		6,044,403	03-2000	Gerszberg et al.	-----	-----	-----
		6,075,992	06-2000	Moon et al.	-----	-----	-----
		6,078,581	06-2000	Shtivelman et al.	-----	-----	-----
		6,084,584	07-2000	Nahi et al.	-----	-----	-----
		6,094,478	07-2000	Shepherd et al.	-----	-----	-----
		6,104,800	08-2000	Benson	-----	-----	-----
		6,141,341	10-2000	Jones et al.	-----	-----	-----
		6,161,134	12-2000	Wang et al.	-----	-----	-----
		6,163,598	12-2000	Moore	-----	-----	-----
		6,167,040	12-2000	Haeggstrom	-----	-----	-----
		6,175,860	01-2001	Gaucher	-----	-----	-----
		6,188,688	02-2001	Buskirk, Jr.	-----	-----	-----
		6,212,261	04-2001	Meubus et al.	-----	-----	-----
		6,216,158	04-2001	Luo et al.	-----	-----	-----
		6,240,097	05-2001	Wesloek et al.	-----	-----	-----
		6,259,692	07-2001	Shtivelman et al.	-----	-----	-----
		6,262,978	07-2001	Bruno et al.	-----	-----	-----

<b>EXAMINER:</b> /Creighton Smith/	<b>DATE CONSIDERED:</b> 03/15/2010
EXAMINER: Initial if reference is considered, whether or not citation is in conformance with MPEP 609; Draw line through citation if not in conformance and not considered. Include a copy of this form with next communication to applicant	

<b>FORM PTO-1449</b>  <b>LIST OF PATENTS AND OTHER ITEMS FOR APPLICANT'S INFORMATION DISCLOSURE STATEMENT</b>  (Use several sheets if necessary)	<b>ATTY. DOCKET NO.</b> TLM-103C1DIV	<b>SERIAL NO.</b> 11/948,965
	<b>APPLICANT:</b> Samuel F. WOOD, et al.	
	<b>FILING DATE:</b> November 30, 2007	<b>GROUP:</b> 2614

U.S. PATENT DOCUMENTS							
EXAMINER INITIAL		DOCUMENT NUMBER	DATE	NAME	CLASS	SUB CLASS	FILING DATE
		6,266,539	07-2001	Pardo	-----	-----	-----
		6,301,609	10-2001	Aravamudan et al.	-----	-----	-----
		6,308,201	10-2001	Pivowar et al.	-----	-----	-----
		6,334,126	12-2001	Nagatomo et al.	-----	-----	-----
		6,337,858	01-2002	Petty et al.	-----	-----	-----
		6,359,892	03-2002	Szlam et al.	-----	-----	-----
		6,385,308	05-2002	Cohen et al.	-----	-----	-----
		6,404,764	06-2002	Jones et al.	-----	-----	-----
		6,411,615	06-2002	DeGolia et al.	-----	-----	-----
		6,411,965	06-2002	Klug	-----	-----	-----
		6,414,962	07-2002	Hall et al.	-----	-----	-----
		6,418,198	07-2002	Brablec et al.	-----	-----	-----
		6,421,235	07-2002	Ditzik	-----	-----	-----
		6,445,694	09-2002	Swartz	-----	-----	-----
		6,445,697	09-2002	Fenton	-----	-----	-----
		6,446,127	09-2002	Shuster et al.	-----	-----	-----
		6,448,978	09-2002	Salvador et al.	-----	-----	-----
		6,456,594	09-2002	Kaplan et al.	-----	-----	-----
		6,456,601	09-2002	Kozdon et al.	-----	-----	-----
		6,477,565	11-2002	Daswani et al.	-----	-----	-----
		6,477,576	11-2002	Angwin et al.	-----	-----	-----
		6,483,902	11-2002	Stewart et al.	-----	-----	-----

<b>EXAMINER:</b> /Creighton Smith/	<b>DATE CONSIDERED:</b> 03/15/2010
EXAMINER: Initial if reference is considered, whether or not citation is in conformance with MPEP 609; Draw line through citation if not in conformance and not considered. Include a copy of this form with next communication to applicant	

<b>FORM PTO-1449</b>  <b>LIST OF PATENTS AND OTHER ITEMS FOR APPLICANT'S INFORMATION DISCLOSURE STATEMENT</b>  (Use several sheets if necessary)	<b>ATTY. DOCKET NO.</b> TLM-103C1DIV	<b>SERIAL NO.</b> 11/948,965
	<b>APPLICANT:</b> Samuel F. WOOD, et al.	
	<b>FILING DATE:</b> November 30, 2007	<b>GROUP:</b> 2614

U.S. PATENT DOCUMENTS							
EXAMINER INITIAL		DOCUMENT NUMBER	DATE	NAME	CLASS	SUB CLASS	FILING DATE
		6,493,338	12-2002	Preston et al.	-----	-----	-----
		6,496,477	12-2002	Perkins et al.	-----	-----	-----
		6,526,462	02-2003	Elabd	-----	-----	-----
		6,539,359	03-2003	Ladd et al.	-----	-----	-----
		6,577,622	06-2003	Shuster et al.	-----	-----	-----
		6,584,490	06-2003	Shuster et al.	-----	-----	-----
		6,650,901	11-2003	Shuster et al.	-----	-----	-----
		6,681,252	01-2004	Shuster et al.	-----	-----	-----
		6,731,630	05-2004	Shuster et al.	-----	-----	-----
		6,741,586	05-2004	Shuster et al.	-----	-----	-----
		6,785,266	08-2004	Swartz	-----	-----	-----
		6,795,429	09-2004	Shuster et al.	-----	-----	-----
		6,804,224	10-2004	Shuster et al.	-----	-----	-----
		6,822,957	11-2004	Shuster et al.	-----	-----	-----
		6,853,714	02-2005	Liljestrand et al.	-----	-----	-----
		6,856,616	02-2005	Shuster et al.	-----	-----	-----
		6,857,021	02-2005	Shuster et al.	-----	-----	-----
		6,857,072	02-2005	Shuster et al.	-----	-----	-----
		6,870,830	03-2005	Shuster et al.	-----	-----	-----
		6,914,897	07-2005	Shuster et al.	-----	-----	-----
		6,937,699	08-2005	Shuster et al.	-----	-----	-----

<b>EXAMINER:</b> /Creighton Smith/	<b>DATE CONSIDERED:</b> 03/15/2010
EXAMINER: Initial if reference is considered, whether or not citation is in conformance with MPEP 609; Draw line through citation if not in conformance and not considered. Include a copy of this form with next communication to applicant	

<b>FORM PTO-1449</b>  <b>LIST OF PATENTS AND OTHER ITEMS FOR APPLICANT'S INFORMATION DISCLOSURE STATEMENT</b>  (Use several sheets if necessary)	<b>ATTY. DOCKET NO.</b> TLM-103C1DIV	<b>SERIAL NO.</b> 11/948,965
	<b>APPLICANT:</b> Samuel F. WOOD, et al.	
	<b>FILING DATE:</b> November 30, 2007	<b>GROUP:</b> 2614

FOREIGN PATENT DOCUMENTS								
EXAMINER INITIAL		DOCUMENT NUMBER	DATE	COUNTRY	CLASS	SUB CLASS	TRANSLATI YE	NO
		DE19813179	09-1999	DE	-----	-----	X	
		EP0578374	01-1994	EP	-----	-----		
		EP0704788	04-1996	EP	-----	-----		
		EP0858202	08-1998	EP	-----	-----		
		EP0869688	10-1998	EP	-----	-----		
		EP0881848	12-1998	EP	-----	-----		
		EP0918423	10-1998	EP	-----	-----		
		WO01/024496	04-2001	WO	-----	-----		
		WO01/024498	04-2001	WO	-----	-----		
		WO01/024500	04-2001	WO	-----	-----		
		WO01/024501	04-2001	WO	-----	-----		
		WO01/024502	04-2001	WO	-----	-----		
		WO01/024503	04-2001	WO	-----	-----		
		WO01/05078	01-2001	WO	-----	-----		
		WO94/05111	03-1994	WO	-----	-----		
		WO95/34985	12-1995	WO	-----	-----		
		WO97/31492	08-1997	WO	-----	-----		
		WO97/33421	09-1997	WO	-----	-----		
		WO97/44943	11-1997	WO	-----	-----		
		WO98/00988	01-1998	WO	-----	-----		
		WO98/04065	01-1998	WO	-----	-----		
		WO98/10538	03-1998	WO	-----	-----		

<b>EXAMINER:</b> /Creighton Smith/	<b>DATE CONSIDERED:</b> 03/15/2010
EXAMINER: Initial if reference is considered, whether or not citation is in conformance with MPEP 609; Draw line through citation if not in conformance and not considered. Include a copy of this form with next communication to applicant	



<b>FORM PTO-1449</b>  <b>LIST OF PATENTS AND OTHER ITEMS FOR APPLICANT'S INFORMATION DISCLOSURE STATEMENT</b>  (Use several sheets if necessary)	<b>ATTY. DOCKET NO.</b> TLM-103C1DIV	<b>SERIAL NO.</b> 11/948,965
	<b>APPLICANT:</b> Samuel F. WOOD, et al.	
	<b>FILING DATE:</b> November 30, 2007	<b>GROUP:</b> 2614

FOREIGN PATENT DOCUMENTS								
EXAMINER INITIAL		DOCUMENT NUMBER	DATE	COUNTRY	CLASS	SUB CLASS	TRANSLATION NO	
		WO98/16051	04-1998	WO	-----	-----		
		WO98/21911	05-1998	WO	-----	-----		
		WO98/30008	07-1998	WO	-----	-----		
		WO98/37665	08-1998	WO	-----	-----		
		WO99/12365	03-1999	WO	-----	-----		
		WO99/19988	04-1999	WO	-----	-----		
		WO99/20059	04-1999	WO	-----	-----		
		WO99/35802	07-1999	WO	-----	-----		
		WO99/45687	09-1999	WO	-----	-----		

OTHER DOCUMENTS (Including Author, Title, Date, Pertinent Pages, etc.)		
EXAMINER INITIAL		
	1	RFC 3298 Service in the PSTN, August 2002
	2	Implementing Automatic Location Update for Follow-Me database using VoIP and Bluetooth Technologies, IEEE Transaction on computers, Vol. 51, No. 10, October 2002
	3	New services demand integration, Electronic Engineering Times, Aug. 28, 2000, Iss. 1128; pg. 110
	4	Natural Microsystems, M2 Presswire. Coventry: Aug, 18, 2000
	5	This pipe dream will come true: Voice Over Internet Protocol (VoIP) technology will make the phone Box something that really talks, Businessline, Chennai: Apr 17, 2002
	6	Using Optimization to Achieve Efficient Quality of Service in Voice over IP Networks, IEEE 2003
	7	Broadsoft literature Broadworks overview, Copyright date 2002
	8	BroadSoft introduces industry's first complete service delivery and creation product suite for enhanced telephony services Broadworks, ATM Newsletter: Boston: March 2000, vol. 9, Iss. 3, pg 13
	9	BroadSoft unveils advanced architecture for the rapid and cost effective delivery of enhanced communications services, Website, August 25, 1999, Press releases, 3 pages.
	10	U.S. patent application Ser. No. 09/406,322, Schuster et al., filed Sep. 27, 1999
	11	U.S. patent application Ser. No. 09/515,798, Schuster et al., filed Feb. 29, 2000

<b>EXAMINER:</b> /Creighton Smith/	<b>DATE CONSIDERED:</b> 03/15/2010
EXAMINER: Initial if reference is considered, whether or not citation is in conformance with MPEP 609; Draw line through citation if not in conformance and not considered. Include a copy of this form with next communication to applicant	

<b>FORM PTO-1449</b>  <b>LIST OF PATENTS AND OTHER ITEMS FOR APPLICANT'S  INFORMATION DISCLOSURE STATEMENT</b>  (Use several sheets if necessary)	<b>ATTY. DOCKET NO.</b> TLM-103C1DIV	<b>SERIAL NO.</b> 11/948,965
	<b>APPLICANT:</b> Samuel F. WOOD, et al.	
	<b>FILING DATE:</b> November 30, 2007	<b>GROUP:</b> 2614

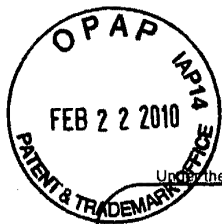
<b>EXAMINER:</b> /Creighton Smith/	<b>DATE CONSIDERED:</b> 03/15/2010
EXAMINER: Initial if reference is considered, whether or not citation is in conformance with MPEP 609; Draw line through citation if not in conformance and not considered. Include a copy of this form with next communication to applicant	

**Information Disclosure Statement – Section 9 PTO-1449**

**Page 8 of 8**

ALL REFERENCES CONSIDERED EXCEPT WHERE LINED THROUGH. /C.S./

KCE/IRW



PTO/SB/30 (07-09)  
Approved for use through 07/31/2012. OMB 0651-0031  
U.S. Patent and Trademark Office; U.S. DEPARTMENT OF COMMERCE  
Under the Paperwork Reduction Act of 1995, no persons are required to respond to a collection of information unless it contains a valid OMB control number.

### Request for Continued Examination (RCE) Transmittal

Address to:  
Mail Stop RCE  
Commissioner for Patents  
P.O. Box 1450  
Alexandria, VA 22313-1450

Application Number	11/948,965
Filing Date	June 7, 2006
First Named Inventor	Samuel F. Wood
Art Unit	2614
Examiner Name	Creighton H. Smith
Attorney Docket Number	TLM-103C1DIV

This is a Request for Continued Examination (RCE) under 37 CFR 1.114 of the above-identified application. Request for Continued Examination (RCE) practice under 37 CFR 1.114 does not apply to any utility or plant application filed prior to June 8, 1995, or to any design application. See Instruction Sheet for RCEs (not to be submitted to the USPTO) on page 2.

1. **Submission required under 37 CFR 1.114** Note: If the RCE is proper, any previously filed unentered amendments and amendments enclosed with the RCE will be entered in the order in which they were filed unless applicant instructs otherwise. If applicant does not wish to have any previously filed unentered amendment(s) entered, applicant must request non-entry of such amendment(s).

a.  Previously submitted. If a final Office action is outstanding, any amendments filed after the final Office action may be considered as a submission even if this box is not checked.

i.  Consider the arguments in the Appeal Brief or Reply Brief previously filed on \_\_\_\_\_

ii.  Other \_\_\_\_\_

b.  Enclosed

i.  Amendment/Reply

ii.  Affidavit(s)/ Declaration(s)

iii.  Information Disclosure Statement (IDS) ~~DA~~

iv.  Other \_\_\_\_\_

2. **Miscellaneous**

a.  Suspension of action on the above-identified application is requested under 37 CFR 1.103(c) for a period of \_\_\_\_\_ months. (Period of suspension shall not exceed 3 months; Fee under 37 CFR 1.17(i) required)

b.  Other \_\_\_\_\_

3. **Fees** The RCE fee under 37 CFR 1.17(e) is required by 37 CFR 1.114 when the RCE is filed. The Director is hereby authorized to charge the following fees, any underpayment of fees, or credit any overpayments, to Deposit Account No. 50-3102.

a.  RCE fee required under 37 CFR 1.17(e)

ii.  Extension of time fee (37 CFR 1.136 and 1.17)

iii.  Other \_\_\_\_\_

b.  Check in the amount of \$ \_\_\_\_\_ enclosed

c.  Payment by credit card (Form PTO-2038 enclosed)

**WARNING: Information on this form may become public. Credit card information should not be included on this form. Provide credit card information and authorization on PTO-2038.**

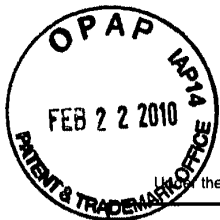
02/23/2010 EAREGAY1 00000000 503102 11948965

SIGNATURE OF APPLICANT, ATTORNEY, OR AGENT REQUIRED			
Signature	/Reena Kuyper/	Date	February 16, 2010
Name (Print/Type)	Reena Kuyper	Registration No.	33,830

CERTIFICATE OF MAILING OR TRANSMISSION			
I hereby certify that this correspondence is being deposited with the United States Postal Service with sufficient postage as first class mail in an envelope addressed to: Mail Stop RCE, Commissioner for Patents, P. O. Box 1450, Alexandria, VA 22313-1450 or facsimile transmitted to the U.S. Patent and Trademark Office on the date shown below.			
Signature	/Reena Kuyper/	Date	February 16, 2010
Name (Print/Type)	Reena Kuyper	Date	February 16, 2010

This collection of information is required by 37 CFR 1.114. The information is required to obtain or retain a benefit by the public which is to file (and by the USPTO to process) an application. Confidentiality is governed by 35 U.S.C. 122 and 37 CFR 1.11 and 1.14. This collection is estimated to take 12 minutes to complete, including gathering, preparing, and submitting the completed application form to the USPTO. Time will vary depending upon the individual case. Any comments on the amount of time you require to complete this form and/or suggestions for reducing this burden, should be sent to the Chief Information Officer, U.S. Patent and Trademark Office, U.S. Department of Commerce, P.O. Box 1450, Alexandria, VA 22313-1450. DO NOT SEND FEES OR COMPLETED FORMS TO THIS ADDRESS. SEND TO: Mail Stop RCE, Commissioner for Patents, P.O. Box 1450, Alexandria, VA 22313-1450.  
If you need assistance in completing the form, call 1-800-PTO-9199 and select option 2.

02/23/2010 EAREGAY1 00000000 11948965  
01 FC:2801 405.00 DA



<b>PETITION FOR EXTENSION OF TIME UNDER 37 CFR 1.136(a)</b>		Docket Number (Optional)
<b>FY 2009</b>		TLM-103C1DIV
<i>(Fees pursuant to the Consolidated Appropriations Act, 2005 (H.R. 4818).)</i>		
Application Number 11/948,965	Filed June 7, 2006	
For <b>BRANCH CALLING AND CALLER ID BASED CALL ROUTING TELEPHONE FEATURES</b>		
Art Unit 2614	Examiner Creighton H. Smith	
This is a request under the provisions of 37 CFR 1.136(a) to extend the period for filing a reply in the above identified application.		
The requested extension and fee are as follows (check time period desired and enter the appropriate fee below):		
	<u>Fee</u>	<u>Small Entity Fee</u>
<input checked="" type="checkbox"/> One month (37 CFR 1.17(a)(1))	\$130	\$65      \$ <u>65.00</u>
<input type="checkbox"/> Two months (37 CFR 1.17(a)(2))	\$490	\$245      \$ _____
<input type="checkbox"/> Three months (37 CFR 1.17(a)(3))	\$1110	\$555      \$ _____
<input type="checkbox"/> Four months (37 CFR 1.17(a)(4))	\$1730	\$865      \$ _____
<input type="checkbox"/> Five months (37 CFR 1.17(a)(5))	\$2350	\$1175      \$ _____
<input checked="" type="checkbox"/> Applicant claims small entity status. See 37 CFR 1.27.		02/23/2010 EAREGAY1 00000000 503102 1948965
<input type="checkbox"/> A check in the amount of the fee is enclosed.		02 FC:2051      65.00 DA
<input type="checkbox"/> Payment by credit card. Form PTO-2038 is attached.		
<input type="checkbox"/> The Director has already been authorized to charge fees in this application to a Deposit Account.		
<input checked="" type="checkbox"/> The Director is hereby authorized to charge any fees which may be required, or credit any overpayment, to Deposit Account Number <u>50-3102</u> .		
<b>WARNING: Information on this form may become public. Credit card information should not be included on this form. Provide credit card information and authorization on PTO-2038.</b>		
I am the <input type="checkbox"/> applicant/inventor.		
<input type="checkbox"/> assignee of record of the entire interest. See 37 CFR 3.71. Statement under 37 CFR 3.73(b) is enclosed (Form PTO/SB/96).		
<input checked="" type="checkbox"/> attorney or agent of record. Registration Number <u>33,830</u>		
<input type="checkbox"/> attorney or agent under 37 CFR 1.34. Registration number if acting under 37 CFR 1.34 _____		
<u>/Reena Kuyper/</u>	<u>February 16, 2010</u>	
Signature	Date	
<u>Reena Kuyper</u>	<u>(310) 247-2860</u>	
Typed or printed name	Telephone Number	
NOTE: Signatures of all the inventors or assignees of record of the entire interest or their representative(s) are required. Submit multiple forms if more than one signature is required, see below.		
<input type="checkbox"/> Total of _____ forms are submitted.		

This collection of information is required by 37 CFR 1.136(a). The information is required to obtain or retain a benefit by the public which is to file (and by the USPTO to process) an application. Confidentiality is governed by 35 U.S.C. 122 and 37 CFR 1.11 and 1.14. This collection is estimated to take 6 minutes to complete, including gathering, preparing, and submitting the completed application form to the USPTO. Time will vary depending upon the individual case. Any comments on the amount of time you require to complete this form and/or suggestions for reducing this burden, should be sent to the Chief Information Officer, U.S. Patent and Trademark Office, U.S. Department of Commerce, P.O. Box 1450, Alexandria, VA 22313-1450. DO NOT SEND FEES OR COMPLETED FORMS TO THIS ADDRESS. SEND TO: Commissioner for Patents, P.O. Box 1450, Alexandria, VA 22313-1450.

If you need assistance in completing the form, call 1-800-PTO-9199 and select option 2.

Application No.:

11/948,965



**IN THE UNITED STATES PATENT AND TRADEMARK OFFICE**

In the Application of:

Samuel F. WOOD, et al.

Serial No.: 11/948,965

Filed: June 7, 2006

For: BRANCH CALLING AND CALLER ID  
BASED CALL ROUTING TELEPHONE  
FEATURES

Customer No.: 49,637

Confirmation No.: 3783

Group Art Unit: 2614

Examiner: Creighton H. Smith

Docket No.: TLM-103.C1DIV

Office Action dated: October 13, 2009

Commissioner for Patents  
P.O. Box 1450  
Alexandria, VA 22313-1450

**SUBSTANCE OF PERSONAL INTERVIEW WITH THE EXAMINER**

Dear Sir:

I. Participants (on behalf of the U.S. Patent Office)

Examiner Creighton Smith

Participants (on behalf of the Applicants)

Samuel F. Wood (Inventor)  
Jerry A. Klein (Inventor)  
Reena Kuyper (Representative of the Applicant)

II. Date of Interview: January 11, 2010

III. Prior Art Discussed

- a. Schwab, et al. (U.S. Patent 6,381,323)
- b. Sidhu, et al. (U.S. Patent 6,744,759) & Shah, et al. (U.S. Patent 6,041,325)

Application No.:

11/948,965

III. Discussion

Applicants and Applicants' Representative presented the differences between the rejected claims and Schwab et al., and other prior art. The major difference lies in that Applicants' architecture permits subscribers to apply features via web access to a controlling device that connects to a switching facility (tandem access switch also referred by other terminology in the industry) so that the features are not limited to a local geographic area. In Schwab, the features are applied at the end office switch, therefore, they are limited only within a local geographic area.

Respectfully submitted,

BERRY & ASSOCIATES P.C.

Dated: February 16, 2010

By:           /Reena Kuyper/          

Reena Kuyper

Registration No. 33,830

9229 Sunset Blvd., Suite 630  
Los Angeles, CA 90069  
(310) 247-2860

Application No.: 11/948,965  
Reply to Office Action of: October 13, 2009



IN THE UNITED STATES PATENT AND TRADEMARK OFFICE

In re the Application of:	)	<b>Customer No.:</b>	49,637
	)		
Samuel F. WOOD, et al.	)	<b>Confirmation No.:</b>	3783
	)		
Serial No.: 11/948,965	)	<b>Group Art Unit:</b>	2614
	)		
Filed: June 7, 2006	)	<b>Examiner:</b>	Creighton H. Smith
	)		
For: BRANCH CALLING AND CALLER ID BASED CALL ROUTING TELEPHONE FEATURES	)	<b>Docket No.:</b>	TLM-103.C1DIV
	)	<b>Office Action dated:</b>	October 13, 2009

Commissioner for Patents  
P.O. Box 1450  
Alexandria, VA 22313-1450

**AMENDMENT & RESPONSE TO FINAL OFFICE ACTION SUBMITTED WITH  
REQUEST FOR CONTINUED EXAMINATION ("RCE")**

Dear Sir:

Prior to examination of this application and in response to the final office action dated October 13, 2009, and further to a personal interview on January 11, 2010, please amend the application as indicated in the following pages. Applicants appreciate the courtesy extended by the Examiner in granting the personal interview and during the interview.

The **Amendments to the Claims** are reflected in the listing of claims, which begins on page 2 of this submission.

The **Remarks/Arguments** begin on page 15 of this submission.

02/23/2010 EAREGAY1 00000000 503102 11948965  
03 FC:2201 440.00 DA

02/23/2010 EAREGAY1 00000000 503102 11948965  
04 FC:2202 200.00 DA

Application No.: 11/948,965  
Reply to Office Action of: October 13, 2009

**IN THE CLAIMS:**

Please amend the claims as indicated. A complete set of the claims is included below, reflecting added subject matter (*with underlining*) and deleted subject matter (*with strikethrough*), as well as the current status of each claim. This listing of claims will replace all prior versions and listings of the claims in this application:

1. (Currently Amended) A method performed by a web-enabled processing system connected ~~within~~ to operate at least in part with a communication network ~~the public-switched telephone network (PSTN)~~ comprising edge switches for routing calls from and to subscribers within a local geographic area and switching facilities for routing calls to other edge switches or other switching facilities local or in other geographic areas, the method comprising the steps of:

receiving a call in response to a calling party entering a first number, using a communications device, intended for a subscriber, the web-enabled processing system coupled to at least one switching facility of the communication network, the web-enabled processing system processing the call pursuant to at least one calling feature designated by said subscriber, where the at least one calling feature had previously been communicated to the web-enabled processing system by said subscriber via the internet;

placing at least two calls simultaneously to at least two different communications devices designated by the subscriber;

detecting that the call has been answered at one of the communications devices;  
and

in response to the detecting, abandoning other calls to the remaining one or more communications devices and establishing a connection between the calling party's communications device and the answered communications device.

2. (Canceled)

3. (Previously Presented) The method of Claim 1 further comprising:  
detecting first information about the source of the call;



Application No.: 11/948,965  
Reply to Office Action of: October 13, 2009

associating the first information with a calling feature, previously selected by the subscriber to be performed on the call, the calling feature being to forward the call to at least two communications devices; and  
simultaneously placing at least two calls to at least two communications devices.

4. (Previously Presented) The method of Claim 1 wherein the at least two calls to the communications devices are any combination of local call, long distance call, cellular call, and VOIP call.

5. (Currently Amended) The method of Claim 1 wherein, when one of the calls to the communications devices is answered, an answer supervision signal is transmitted to the processing system, and the processing system ~~terminates~~ abandons the other calls.

6. (Original) The method of Claim 5 wherein the answer supervision is pursuant to the SS7 signaling protocol.

7. (Currently Amended) The method of Claim 1 wherein the web-enabled processing system is connected to the switching facility, which is a PSTN tandem switch within the communication network, which is a public switched telephone network (PSTN) PSTN, and wherein receiving a call from a calling party comprises the steps of:

receiving a first call through the tandem switch from the calling party intended for the subscriber after the calling party has entered a first telephone number, the first telephone number being the subscriber's public telephone number, said processing system simultaneously placing at least second and third calls using second and third telephone numbers different from the first telephone number.

8. (Canceled)

9. (Canceled)

Application No.: 11/948,965  
Reply to Office Action of: October 13, 2009

10. (Currently Amended) A controller connected within the public switched telephone network (PSTN) and configured to perform enhanced routing operations, comprising:

a processing system connected within the PSTN and linked ~~to~~ via the internet for selecting at least one calling feature ~~via the internet~~, the processing system ~~programmed~~ configured to perform the steps of the process comprising:

receiving a call from a calling party, using a communications device, intended for a subscriber, whereby said processing system implements a calling feature previously designated by said subscriber via the internet;

placing at least two calls simultaneously to at least two different communications devices previously designated by the subscriber;

detecting that the call has been answered at one of the communications devices;  
and

in response to the detecting, abandoning other calls to the remaining one or more communications devices and establishing a connection between the calling party's communications device and the answered communications device.

11. (Canceled)

12. (Currently Amended) The controller of Claim 10 wherein the processing system is ~~programmed~~ configured to perform the process comprising the additional steps of:

detecting first information about the source of the call;

associating the first information with a feature, selected by the subscriber, to be performed on the call, the feature being to forward the call to the at least two different communications devices; and

simultaneously placing the at least two calls to the at least two different communications devices.

13. (Previously Presented) The controller of Claim 10 wherein the at least two calls to the communications devices are any combination of local call, long distance call, cellular call, and VOIP call.

Application No.: 11/948,965  
Reply to Office Action of: October 13, 2009

14. (Currently Amended) The controller of Claim 10 wherein, when one of the calls to the communications devices is answered, an answer supervision signal is transmitted to the processing system, and the processing system ~~terminates~~ abandons the other calls.

15. (Currently Amended) The controller of Claim 10 wherein the processing system is connected to a PSTN tandem switch within the PSTN, and wherein receiving a call from a calling party comprises the step of:

receiving a first call through the tandem switch from the calling party intended for the subscriber after the calling party has entered a first telephone number, the first telephone number being the subscriber's public telephone number, said processing system simultaneously placing at least second and third calls using second and third telephone numbers different from the first telephone number.

16. (Original) The controller of Claim 10 wherein the processing system is connected to the PSTN in the subscriber's local service area.

17. (Original) The controller of Claim 10 wherein the subscriber is a subscriber of residential telephone service.

18. (Previously Presented) The controller of Claim 10 wherein the subscriber is a subscriber of business telephone service.

19. (Currently Amended) A method performed by a processing system coupled to a switching facility for routing calls to edge switches or other switching facilities in local or other geographic areas, within the public switched telephone network (PSTN) a communication network, comprising the steps of:

placing at least two calls simultaneously to at least two different communications devices designated by a subscriber using a communications device, the processing system processing the calls pursuant to at least one calling feature designated by said subscriber,

Application No.: 11/948,965  
Reply to Office Action of: October 13, 2009

where the at least one calling feature had previously been communicated to the processing system by said subscriber via the internet;

receiving the at least two calls made simultaneously to said at least two different communications devices designated by said subscriber via the internet;

detecting that one of the calls has been answered at one of the communications devices; and

in response to the detecting, abandoning other calls to the remaining one or more communications devices and establishing a connection between said subscriber's communications device and the answered communications device.

20. (Currently Amended) A controller connected to a tandem switch within the public switched telephone network (PSTN) comprising:

a processing system linked to the internet for allowing a subscriber to select at least one calling feature over the web, the processing system ~~programmed~~ configured to perform the process comprising the steps of:

placing at least two calls simultaneously to at least two different communications devices designated by a subscriber using a communications device, the processing system processing the calls pursuant to at least one calling feature designated by said subscriber, where the at least one calling feature had previously been communicated to the processing system by said subscriber via the internet;

receiving at least two calls made simultaneously to said at least two different communications devices designated by the subscriber via the internet;

detecting that the call has been answered at one of the communications devices; and

in response to the detecting, abandoning other calls to the remaining one or more communications devices and establishing a connection between the calling party's communications device and the answered communications device.

Application No.: 11/948,965  
Reply to Office Action of: October 13, 2009

21. (Currently Amended) A controller connected to a switching facility allowing access to local and other geographic areas within the public switched telephone network (PSTN) comprising:

a processing system linked to the internet for allowing a subscriber to select at least one calling feature via the internet, the processing system ~~programmed~~ configured to perform the process comprising the steps of:

receiving a call under the control of said controller from a calling party, using a communications device, intended for a subscriber, the processing system processing the call pursuant to at least one calling feature designated by said subscriber, where the at least one calling feature had previously been communicated to the processing system by said subscriber via the internet;

invoking the at least one calling feature prior to said received call reaching a terminating central office, said at least one calling feature placing at least two calls simultaneously to at least two different communications devices previously designated by said subscriber;

detecting that one of at least two calls has been answered at one of the communications devices; and

in response to the detecting, abandoning other calls to the remaining one or more communications devices and establishing a connection between the calling party's communications device and the answered communications device.

Please add the following new claims indicated below.

22. (New) A method for processing an incoming call from a switching facility on a communication network that comprises edge switches for routing calls to subscribers within a local geographic area and switching facilities for routing calls to edge switches, or other switching facilities local or in other geographic areas the method comprising the steps of:

receiving a first call, which is intended for a specified recipient, at a controlling device in communication with the switching facility;

Application No.: 11/948,965  
Reply to Office Action of: October 13, 2009

identifying one or more control criteria previously associated with the specified recipient, wherein the one or more control criteria was entered via a web-based interface;  
initiating a second call at the controlling device in accordance with the control criteria associated with the specified recipient; and  
connecting the first and second calls at the controlling device after the second call is received by a communication device associated with the specified recipient.

23. (New) A method as defined in claim 22, wherein the communication network comprises any one or more of a switched network, a packet-based network, and a wireless network.

24. (New) A method as defined in claim 22, wherein the communication device is a digital device.

25. (New) A method as defined in claim 22, wherein the controlling device is implemented using a distributed architecture spanning at least two locations.

26. (New) A method as defined in claim 22, wherein the controlling device utilizes a programmed processor utilizing the TDM architecture.

27. (New) A method as defined in claim 22, wherein the controlling device utilizes a programmed processor utilizing packet switching.

28. (New) A method as defined in claim 22, wherein the controlling device utilizes a programmed processor utilizing a voice over IP (VoIP) architecture.

29. (New) A method as defined in claim 22, wherein at least one of the first and second calls is facilitated via a VoIP connection.

Application No.: 11/948,965  
Reply to Office Action of: October 13, 2009

30. (New) A method as defined in claim 22, wherein at least either of the first call or the second call is routed within the communication network.

31. (New) A method as defined in claim 22, wherein both the first and second calls are facilitated via VoIP connections.

32. (New) A method as defined in claim 22, wherein the controlling device is located within a local service area corresponding to the specified recipient.

33. (New) A method as defined in claim 22, wherein the controlling device is configured as a tandem access controller.

34. (New) A method as defined in claim 33, wherein the tandem access controller is coupled to and operates in conjunction with at least one of the switching facilities located within the communication network.

35. (New) A method as defined in claim 22, wherein both the first and second calls are routed within the communication network.

36. (New) A method as defined in claim 22, wherein at least either one of the first and second calls is facilitated over a wireless link.

37. (New) A method as defined in claim 22, wherein the communication network may use any one of a wired telephone device, a computing device, a wireless device, a cellular device, a portable device with cellular capability, and an information appliance.

38. (New) A method as defined in claim 22, wherein the communication network comprises a network of switching facilities performing a class 4 switching function.

Application No.: 11/948,965  
Reply to Office Action of: October 13, 2009

39. (New) A method as defined in claim 22, wherein the communication network comprises a network of class 4 switches.

40. (New) A method as defined in claim 22, where the control criteria are executed by the controlling device to perform one or more of the following operations:

- a) Web-Based Telecom Navigator;
- b) Manage Incoming Call Control;
- c) Conditional Call Blocking/Forwarding/Alerting; Call Screening/Retrieval from Voice Mail;
- d) Interactive Voice Response and Speech Recognition;
- e) Manage Outgoing Call Control;
- f) Click-to-Dial Calling;
- g) Group Calling and Messaging;
- h) Web-Based Billing;
- i) Cost-Effective Single Phone Number Access;
- j) Free Local Calls, Incoming Calls (not 800 Toll Service);
- k) Retain Current Number (Local Number Portability);
- l) Low-Cost Calling Throughout LATA;
- m) Flat-Rate Foreign Exchange;
- n) Standard DTMF and VoIP Phones;
- o) Centralized and Consistent Personal Data;
- p) Private/Public Phone Directories and Calendars;
- q) "Post-It" Style Annotation of Numbers;
- r) Web Dialing;
- s) Click-to-Dial from Web Pages, Directories, Calendars; Multiple Phone List Management; Voice Mail Access, Prompts, Alert Via Web; Mode-Based Definition and Selection, comprising Time-of-Day, Day-of-Week, Follow-Me, Caller Recognition/Password, Caller ID, Vacation, Dinner Time, Go Away, Family Call Waiting; Learning Modes; Automatic Data Capture; Build Phone List Based on Collected



Application No.: 11/948,965  
Reply to Office Action of: October 13, 2009

Usage Information; VoIP Link Degradation Detection; and Automatic Cutover to the public switched communication network.

41. (New) A method for processing an incoming call from a switching facility on a communication network that comprises edge switches for routing calls within a local geographic area and switching facilities for routing calls to other geographic areas, the method comprising the steps of:

receiving a first call, at a controlling device in communication with the switching facility; which is intended for a specified recipient;

identifying one or more control criteria previously associated with the specified recipient, wherein the one or more control criteria are entered via a web-based interface;

initiating a second call at the controlling device via a packet-based connection in accordance with the control criteria associated with the specified recipient; and

connecting the first and second calls at the controlling device after the second call is received by a communication device associated with the specified recipient.

42. (New) A method as defined in claim 41, wherein the specified recipient uses a communication device in communication with the controlling device via a web interface by which the specified recipient can view the status of calls or features designations.

43. (New) A method as defined in claim 42, wherein the communication device is any one of a wired telephone device, a computing device, a wireless device, a cellular device, a portable device with cellular capability, a digital device, and an information appliance.

44. (New) A method as defined in claim 41, wherein the control criteria are executed by the controlling device to perform one or more of the following operations:

- a) Web-Based Telecom Navigator;
- b) Manage Incoming Call Control;
- c) Conditional Call Blocking/Forwarding/Alerting; Call Screening/Retrieval from Voice Mail;

Application No.: 11/948,965  
Reply to Office Action of: October 13, 2009

- d) Interactive Voice Response and Speech Recognition;
- e) Manage Outgoing Call Control;
- f) Click-to-Dial Calling;
- g) Group Calling and Messaging;
- h) Web-Based Billing;
- i) Cost-Effective Single Phone Number Access;
- j) Free Local Calls, Incoming Calls (not 800 Toll Service);
- k) Retain Current Number (Local Number Portability);
- l) Low-Cost Calling throughout LATA;
- m) Flat-Rate Foreign Exchange;
- n) Standard DTMF and VoIP Phones;
- o) Centralized and Consistent Personal Data;
- p) Private/Public Phone Directories and Calendars;
- q) "Post-It" Style Annotation of Numbers;
- r) Web Dialing;
- s) Click-to-Dial from Web Pages, Directories, Calendars; Multiple Phone List Management; Voice Mail Access, Prompts, Alert Via Web; Mode-Based Definition and Selection, comprising Time-of-Day, Day-of-Week, Follow-Me, Caller Recognition/Password, Caller ID, Vacation, Dinner Time, Go Away, Family Call Waiting; Learning Modes; Automatic Data Capture; Build Phone List Based on Collected Usage Information; VoIP Link Degradation Detection; and Automatic Cutover to the public switched communication network.

45. (New) A method as defined in claim 41, wherein the packet-based connection includes a VOIP connection.

46. (New) A method for processing an incoming call from a switching facility on a communication network that comprises edge switches for routing calls within a local geographic area and switching facilities for routing calls to other geographic areas, the method comprising the steps of:

Application No.: 11/948,965  
Reply to Office Action of: October 13, 2009

receiving a first call, which is intended for a specified recipient, at a controlling device in communication with the switching facility;

identifying one or more control criteria previously associated with the specified recipient, wherein the one or more control criteria are previously entered via a web-based interface; and

initiating one or more calls at the controlling device in accordance with the control criteria associated with the specified recipient; and

if the one or more calls are not answered by the specified recipient, routing the first call from the controlling device to a voicemail server.

47. (New) A method as defined in claim 46, wherein the communication network comprises a network of switching facilities performing a class 4 switching function.

48. (New) A method as defined in claim 46, wherein the communication network comprises a network of class 4 switches.

49. (New) A method for processing an incoming call from a switching facility on a communication network that comprises edge switches for routing calls within a local geographic area and switching facilities for routing calls to other geographic areas, the method comprising the steps of:

receiving a first call, which is intended for a specified recipient, at a controlling device in communication with the switching facility;

identifying one or more control criteria previously associated with the specified recipient, wherein the one or more control criteria are entered via a web-based interface; and

routing the first call from the controlling device to a voicemail server in accordance with the control criteria associated with the specified recipient.

50. (New) A method for processing an incoming call from a switching facility on a communication network that comprises edge switches for routing calls within a local geographic

Application No.: 11/948,965  
Reply to Office Action of: October 13, 2009

area and switching facilities for routing calls to other geographic areas, the method comprising the steps of:

receiving a first call, which is intended for a specified recipient, at a controlling device in communication with one of the switching facilities;

identifying a control criteria previously associated with the specified recipient, wherein the control criteria is previously entered via a web-based interface and instructs the controlling device to block calls for the specified recipient; and

blocking the first call received at the controlling device in accordance with the control criteria.

Application No.: 11/948,965  
Reply to Office Action of: October 13, 2009

### REMARKS

In response to the final office action dated October 13, 2009, and a personal interview with the Examiner on January 11, 2010, Applicants submit a Request for Continued Examination (“RCE”) and an Amendment. At the outset, Applicants and the undersigned appreciate the Examiner’s courtesy during the personal interview. Claims 1, 3-7, 10, and 12-21 are pending in this application and stand rejected under new grounds for rejection stated in the final office action. In addition, contemporaneously with these submissions, Applicants also submit a Supplemental Information Disclosure citing references and information from the other pending related applications and of which the Applicants have become aware. By this Amendment, Applicants have amended claims 1, 5, 7, 10, 12, 14, 15, 19, 20, and 21, and present new claims 22-50 for the Examiner’s continued consideration. Applicants have also demonstrated reasons why the claims in their present form are distinct from the art asserted by the Examiner and the art of record. Reconsideration of this application based on the amendments to the claims and the arguments urged here is respectfully requested.

#### 35 U.S.C. § 103 Rejections

On page 2 of the office action, the Examiner rejected Claims 1, 4-7, 10, 13-21 under 35 U.S.C. Section 103(a) as unpatentable over Schwab et al. (U.S. Patent 6,381,323) in view of Sidhu et al. (U.S. Patent 6,744,759) or Shah et al. (U.S. Patent 6,041,325).

On page 4 of the office action, the Examiner rejected Claims 3 and 12 under 35 U.S.C. Section 103(a) as unpatentable over Schwab et al. (U.S. Patent 6,744,759) in view of Sidhu et al. (U.S. Patent 6,744,759) and further in view of Kugell et al. (U.S. Patent 5,802,160).

Applicants have described below the criteria for a 103 rejection and then, have demonstrated how the combination of the references does not teach all the elements of the Applicants’ claims.

#### *I. Governing Criteria for a 35 U.S.C. § 103 Rejection*

For rejections under 35 U.S.C. Section 103, the establishment of a *prima facie* case of obviousness requires that all the claim limitations must be taught or suggested by the prior art.

Application No.: 11/948,965  
Reply to Office Action of: October 13, 2009

MPEP § 2143.03 The establishment of a prima facie case of obviousness requires that the claimed combination cannot change the principle of operation of the primary reference or render the reference inoperable for its intended purpose. MPEP § 2143.03.

The Supreme Court set the standard for evaluating obviousness in its recent decision (*KSR International Co. v. Teleflex Inc. et al.* (550 U.S. 127 S. Ct. 1727 (2007))) to be “expansive and flexible” and “functional.” However, the standard is not controlling, rather, the various noted factors only “can” or “might” be indicative of obviousness based on the facts. The Supreme Court in *KSR* enunciated the following principles:

“[w]hen a work is available in one field of endeavor, design incentives and other market forces can prompt variations of it, either in the same field or a different one. If a person of ordinary skill can implement a predictable variation, Section 103 likely bars it patentability. For the same reason, if a technique has been used to improve one device, and a person of ordinary skill in the art would recognize that it would improve similar devices in the same way, using the technique is obvious unless its actual application is beyond his or her skill...[A] court must ask whether the improvement is more than the predictable use of prior art elements according to their established functions.

Simply using the benefit of hindsight in combining references is improper. *In re Lee*, 277 F.3d 1338, 1342-45 (Fed. Cir. 2002); *In re Deminski*, 796 F.2d 436, 442 (Fed. Cir. 1986)). The Supreme Court while recognizing the need “to guard against slipping into the use of hindsight,” acknowledged the following principles:

[r]ejection on obviousness grounds cannot be sustained by mere conclusory statements; instead, there must be some articulated reasoning with some rational underpinning to support the legal conclusion of obviousness.

[I]t can be important to identify a reason that would have prompted a person of ordinary skill in the relevant field to combine the elements in the way the claimed new invention does.

One of the ways in which a patent’s subject matter can be proved obvious is by noting that there existed at the time of invention a known problem for which there was an obvious solution encompassed by the patent’s claims.

Rather, obviousness is to be determined from the vantage point of a hypothetical person having ordinary skill in the art to which the patent pertains. See 35 U.S.C. § 103(a). The legal construct

Application No.: 11/948,965  
Reply to Office Action of: October 13, 2009

also presumes that all prior art references in the field of the invention are available to this hypothetical skilled artisan. *In re Carlson*, 983 F.2d 1032, 1038, 25 USPQ 2d 1207, 1211 (Fed. Cir. 1993). The Supreme Court in *KSR* stated that:

a patent composed of several elements is not proved obvious merely by demonstrating that each of its elements was independently, known in the prior art.

An examiner may often find every element of a claimed invention in the prior art. “Virtually all [inventions] are combinations of old elements.” *Environmental Designs, Ltd. V. Union Oil Co.*, 713 F.2d 693, 698, 218 USPQ 865, 870 (Fed.Cir. 1983), cert. denied, 464 U.S. 1043 (1984); see also *Richel, Inc. v. Sunspool Corp.*, 714 F.2d 1573, 1579-80, 219 USPQ 8, 12 (Fed.Cir. 1983). If identification of each claimed element in the prior art were sufficient to negate patentability, very few patents would ever issue. Furthermore, rejecting patents solely by finding prior art corollaries for the claimed elements would permit an examiner to use the claimed invention itself as a blueprint for piecing together elements in the prior art to defeat the patentability of the claimed invention. Such an approach would be “an illogical and inappropriate process by which to determine patentability.” *Sensonics, Inc. v. Aerosonic Corp.*, 81 F.3d 1566, 1570, 38 U.S.P.Q.2d 1551, 1554 (Fed.Cir.1996). In other words, the examiner must show reasons that the skilled artisan, confronted with the same problems as the inventor and with no knowledge of the claimed invention, would select the elements from the cited prior art references for combination in the manner claimed. The Supreme Court in *KSR* has also stated that:

[o]ften, it will be necessary for a court to look to interrelated teachings of multiple patents; the effects of demands known to the design community or present in the market place.

Further, the Supreme Court states that:

The Court relied upon the corollary principle that when the prior art **teaches away** from combining certain known elements, discovery of a successful means of combining them is more likely to be nonobvious.

Application No.: 11/948,965  
Reply to Office Action of: October 13, 2009

## ***II. Discussion of the 35 U.S.C. § 103 Rejections***

On page 2 of the office action, the Examiner rejected claims 1, 4-7, 10, 13-21 as unpatentable over the patent to Schwab et al., in view of the patent to Sidhu et al., or the patent to Shah et al. The Examiner alleges that,

*Schwab et al disclose in col. 1, lines 40 et seq. a method of routing incoming phone calls that includes the steps of coupling an incoming call to a subscriber to a platform, then in step (e) Schwab et al disclose "if it is determined that a 'simultaneous' search feature is active, then the incoming call will be directed to all number's on the subscriber's simultaneous list stored on the platform. In col. 4, lines 43, et seq. Schwab et al disclose that if the subscriber chooses simultaneous ring option, all of the phone numbers selected by the subscriber will ring at once until one of the phone numbers is answered. Schwab et al never specifically disclose that once a phone answers the call that the other phones will abandon the call, but this is inherently what is happening because once the call is answered the network will abandon/cease calling the other phones in order to conserve network resources and thus save money.*

*Schwab et al processing platform 18 is deemed to be within the PSTN, and is NOT considered to be an "edge device." According to Newton's Telecom Dictionary, page 352, 23<sup>rd</sup> Ed., an edge device is defined as a physical device capable of forwarding packets between legacy interworking interfaces and ATM interfaces. A physical device that sits on edges of the internet under control of the ISP. Newton's Dictionary defines the PSTN, page 748, as the "entire interconnected collection of local, long distance, and international phone companies. No where in Schwab et al is there any disclosure of the Internet or packets/frames. Neither does Schwab et al call their processing platform an "edge device." Therefore, since Schwab et al neither disclose the Internet or packet transmission nor do they disclose that platform 18 to be an "edge*



Application No.:

11/948,965

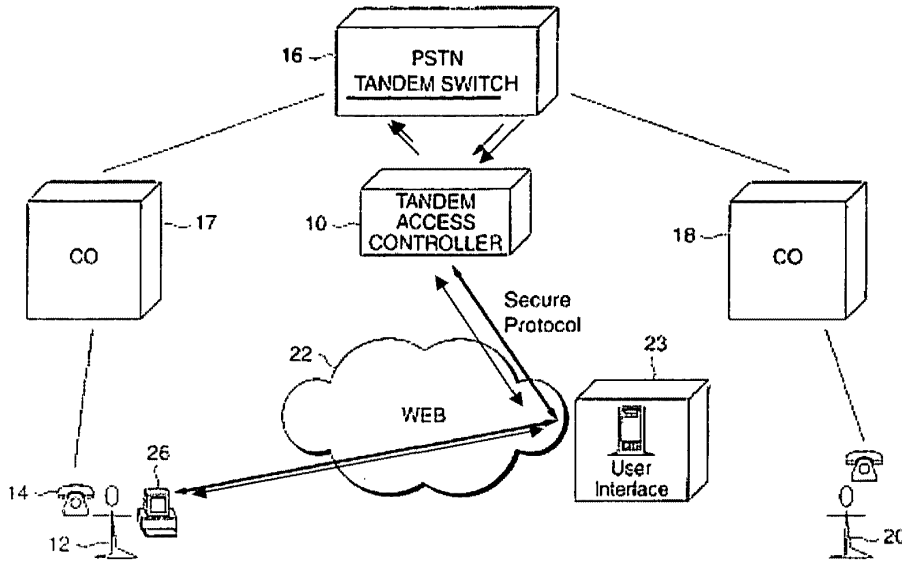
Reply to Office Action of:

October 13, 2009

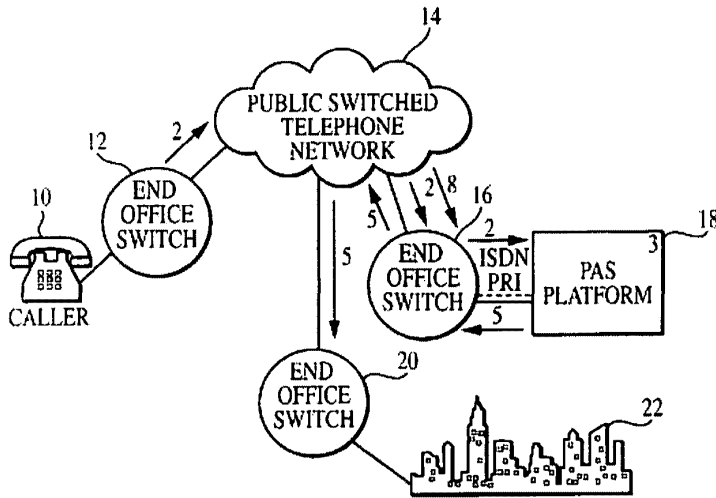
*device,” the Examiner disagrees with applicants['] assertion that platform 18 is an edge device. Even though Schwab et al has not included the EO (12, 16, 20), platform 18, and caller 10 within the PSTN cloud 14 in the drawings, all those elements are deemed to be within the PSTN according to Newton’s definition of the PSTN.*

*Schwab et al do not disclose that the service features provisioning is done through the Internet. However, Sidhu et al disclose in claim 4 a provisioning function that provides a feature request form to a user on one of the data channels, with the feature request form to a user on one of the data channels, with the feature request form being presented to the user in a web browser. Shah et al teach in Fig. 6 and col. 11, lines 12 et seq. that access point 30 presents users with Internet browser screens the ability to provision services. Some of the specific service provisions shown in Fig. 5 are call waiting and call forwarding. To have provided either Sidhu or Shah et al teaching of allowing a user/subscriber to provision telephony service features through the Internet in Schwab et al device would have been obvious to a person having ordinary skill in the art because both references are teaching different service features available to users and skilled in artisan in this art would have used common sense to combine the features of the references together.*

Applicants followed the Examiner’s attempted reasoning and explained the differences, during the personal interview, between Schwab et. al., the other asserted prior art, and their system. As indicated during the personal interview, Schwab demonstrates an architecture (see below Schwab’s figure in comparison with Applicants’ figure, also discussed during the personal interview) distinct from Applicants’ architecture that is claimed here.



TELEMAZE



SCHWAB

Applicants respectfully submit that in Schwab, any “features” that are applied to calls being routed are via an end office switch (also referred to as an edge switch or a central office (CO) switch). The end office switch connects calls from calling (telephone company subscribers) parties to called parties only within a local geographic area. Consistent with Newton’s definition, on which the Examiner relies, Schwab’s “end office switch” could arguably

Application No.: 11/948,965  
Reply to Office Action of: October 13, 2009

be considered to be “within” the PSTN. The PSTN is a configuration of switching facilities for routing calls from calling parties to called parties, comprising a plurality of end office switches (also referred to as central office switches or edge switches (e.g., a class 5 switch)) and a plurality of interconnected switching facilities (also referred to as tandem switches). The end office switches connect calling parties to called parties only within a local geographic area. The tandem switching facilities route calls received via end office switches or other tandem switching facilities to called parties within other geographic areas (national or international, beyond the local geographic area that a subscriber is in). Typically, a telephone call involves an originating end office switch, a plurality of tandem switches, and a terminating end office switch. Therefore, in Schwab, the application of “features” to call routing operations is restricted within the local geographic area of a particular end office switch (local to the calling party that originates the call).

Applicants’ architecture is not only distinct, but a significant improvement over Schwab or any of the other art asserted by the Examiner or of record, because it facilitates application of “features” to call routing operations anywhere in the network (geographic areas beyond the local geographic area). Applicants’ architecture permits subscribers (called parties or third parties) to access call routing operations at the switching facilities (also referred to as tandem switching facilities<sup>1</sup>) that interconnect end office switches to other geographic areas that are not local to an end office switch. Applicants’ have amended the claims here to emphasize this distinction. Rather than to simply refer to a “PSTN,” the claims now define the various components of the PSTN architecture and indicate the point (switching facility within the PSTN) at which Applicants’ system has access to apply the “features” requested by a subscriber to call routing operations. In addition, neither Sidhu nor Shah discloses the architecture that is lacking in Schwab and claimed here. The Examiner relies on these references for a teaching of web access, which he acknowledges is also lacking in Schwab. Even with a teaching of web access in either Sidhu or Shah, a combination of all three references does not meet all the elements of the claims at issue here.

---

<sup>1</sup> Any point in the switching fabric of converging networks, also referred to in industry as a signal transfer point (STP), signal control point (SCP), session border controller (SBC), gateway, access tandem, class 4 switch, wire center, toll office, toll center, PSTN switching center, intercarrier connection point, trunk gateway, hybrid switch, etc.

Application No.: 11/948,965  
Reply to Office Action of: October 13, 2009

Specifically, the claims define receiving first calls at a controller facility (also referred to as a tandem access controller) and applying "features" that were previously designated, via web access, by the subscribers, and then, making second calls, if necessary, to accomplish the designated features. Applicants have also presented some new claims for the Examiner's consideration, including ones that define the particular features, for example, routing to voice mail and call blocking.

Moreover, although Kugell discloses tandem switching facilities, it does not disclose Applicants' architecture for applying "features." Instead, Kugell suggests major modifications to the PSTN.

Applicants submit that claims 1, 4-7, 10, and 13-21 are distinct for the reasons demonstrated above. The Examiner is respectfully requested to withdraw the rejections of claims 1, 4-7, 10, and 13-21. In addition, claims 3 and 12 are distinct by virtue of their dependency on claims 1 and 10, respectively, from which they depend. Again, the Examiner is respectfully requested to withdraw the rejections of these claims and to allow them.

***Conclusion***

Favorable reconsideration of the rejected claims and the new claims presented here is respectfully requested. In addition, Applicants and the undersigned request the Examiner to kindly call the undersigned in the event outstanding issues remain, in order to expedite conclusion of prosecution of this application.

Respectfully submitted,

BERRY & ASSOCIATES P.C.

Dated: February 16, 2010

By:           /Reena Kuyper/            
Reena Kuyper  
Registration No. 33,830

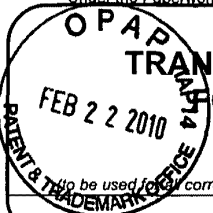
9229 Sunset Blvd., Suite 630  
Los Angeles, CA 90069  
(310) 247-2860

Doc Code: TRAN.LET

Document Description: Transmittal Letter

Approved for use through 07/31/2012. OMB 0651-0031  
U.S. Patent and Trademark Office; U.S. DEPARTMENT OF COMMERCE

Under the Paperwork Reduction Act of 1995, no persons are required to respond to a collection of information unless it displays a valid OMB control number.

	Application Number	11/948,965
	Filing Date	June 7, 2006
	First Named Inventor	Samuel F. Wood
	Art Unit	2614
	Examiner Name	Creighton H. Smith
Attorney Docket Number		TLM-103C1DIV
Total Number of Pages in This Submission		

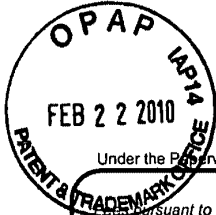
ENCLOSURES (Check all that apply)		
<input checked="" type="checkbox"/> Fee Transmittal Form	<input type="checkbox"/> Drawing(s)	<input type="checkbox"/> After Allowance Communication to TC
<input checked="" type="checkbox"/> Fee Attached	<input type="checkbox"/> Licensing-related Papers	<input type="checkbox"/> Appeal Communication to Board of Appeals and Interferences
<input checked="" type="checkbox"/> Amendment/Reply	<input type="checkbox"/> Petition	<input type="checkbox"/> Appeal Communication to TC (Appeal Notice, Brief, Reply Brief)
<input checked="" type="checkbox"/> After Final	<input type="checkbox"/> Petition to Convert to a Provisional Application	<input type="checkbox"/> Proprietary Information
<input type="checkbox"/> Affidavits/declaration(s)	<input type="checkbox"/> Power of Attorney, Revocation	<input type="checkbox"/> Status Letter
<input checked="" type="checkbox"/> Extension of Time Request	<input type="checkbox"/> Change of Correspondence Address	<input checked="" type="checkbox"/> Other Enclosure(s) (please identify below):
<input type="checkbox"/> Express Abandonment Request	<input type="checkbox"/> Terminal Disclaimer	Request for Continued Examination
<input type="checkbox"/> Information Disclosure Statement	<input type="checkbox"/> Request for Refund	Substance of Personal Interview with Examiner
<input type="checkbox"/> Certified Copy of Priority Document(s)	<input type="checkbox"/> CD, Number of CD(s) _____	
<input type="checkbox"/> Reply to Missing Parts/ Incomplete Application	<input type="checkbox"/> Landscape Table on CD	
<input type="checkbox"/> Reply to Missing Parts under 37 CFR 1.52 or 1.53	Remarks	

SIGNATURE OF APPLICANT, ATTORNEY, OR AGENT			
Firm Name	Berry & Associates P.C.		
Signature	/Reena Kuyper/		
Printed name	Reena Kuyper		
Date	February 16, 2010	Reg. No.	33,830

CERTIFICATE OF TRANSMISSION/MAILING			
I hereby certify that this correspondence is being facsimile transmitted to the USPTO or deposited with the United States Postal Service with sufficient postage as first class mail in an envelope addressed to: Commissioner for Patents, P.O. Box 1450, Alexandria, VA 22313-1450 on the date shown below:			
Signature	/Reena Kuyper/		
Typed or printed name	Reena Kuyper	Date	February 16, 2010

This collection of information is required by 37 CFR 1.5. The information is required to obtain or retain a benefit by the public which is to file (and by the USPTO to process) an application. Confidentiality is governed by 35 U.S.C. 122 and 37 CFR 1.11 and 1.14. This collection is estimated to 2 hours to complete, including gathering, preparing, and submitting the completed application form to the USPTO. Time will vary depending upon the individual case. Any comments on the amount of time you require to complete this form and/or suggestions for reducing this burden, should be sent to the Chief Information Officer, U.S. Patent and Trademark Office, U.S. Department of Commerce, P.O. Box 1450, Alexandria, VA 22313-1450. DO NOT SEND FEES OR COMPLETED FORMS TO THIS ADDRESS. SEND TO: Commissioner for Patents, P.O. Box 1450, Alexandria, VA 22313-1450.

If you need assistance in completing the form, call 1-800-PTO-9199 and select option 2.



PTO/SB/17 (10-08)

Approved for use through 06/30/2010. OMB 0651-0032

U.S. Patent and Trademark Office; U.S. DEPARTMENT OF COMMERCE

Under the Paperwork Reduction Act of 1995 no persons are required to respond to a collection of information unless it displays a valid OMB control number

Effective on 12/08/2004.  
Pursuant to the Consolidated Appropriations Act, 2005 (H.R. 4818).

## FEE TRANSMITTAL For FY 2009

Applicant claims small entity status. See 37 CFR 1.27

TOTAL AMOUNT OF PAYMENT		(\$) 1118	
<b>Complete if Known</b>			
Application Number	11/948,965		
Filing Date	June 7, 2006		
First Named Inventor	Samuel F. Wood		
Examiner Name	Creighton H. Smith		
Art Unit	2614		
Attorney Docket No.	TLM-103C1DIV		

**METHOD OF PAYMENT** (check all that apply)

Check  Credit Card  Money Order  None  Other (please identify): \_\_\_\_\_

Deposit Account Deposit Account Number: 50-3102 Deposit Account Name: Berry & Associates P.C.

For the above-identified deposit account, the Director is hereby authorized to: (check all that apply)

Charge fee(s) indicated below  Charge fee(s) indicated below, except for the filing fee

Charge any additional fee(s) or underpayments of fee(s) under 37 CFR 1.16 and 1.17  Credit any overpayments

**WARNING:** Information on this form may become public. Credit card information should not be included on this form. Provide credit card information and authorization on PTO-2038.

**FEE CALCULATION**

**1. BASIC FILING, SEARCH, AND EXAMINATION FEES**

Application Type	FILING FEES		SEARCH FEES		EXAMINATION FEES		Fees Paid (\$)
	Fee (\$)	Small Entity Fee (\$)	Fee (\$)	Small Entity Fee (\$)	Fee (\$)	Small Entity Fee (\$)	
Utility	330	165	540	270	220	110	_____
Design	220	110	100	50	140	70	_____
Plant	220	110	330	165	170	85	_____
Reissue	330	165	540	270	650	325	_____
Provisional	220	110	0	0	0	0	_____

**2. EXCESS CLAIM FEES**

Fee Description	Fee (\$)	Small Entity Fee (\$)
Each claim over 20 (including Reissues)	52	26
Each independent claim over 3 (including Reissues)	220	110
Multiple dependent claims	390	195

**Total Claims**      **Extra Claims**      **Fee (\$)**      **Fee Paid (\$)**      **Multiple Dependent Claims**

28 - 20 or HP = 8 x 26 = 208      **Fee (\$)**      **Fee Paid (\$)**

HP = highest number of total claims paid for, if greater than 20.

**Indep. Claims**      **Extra Claims**      **Fee (\$)**      **Fee Paid (\$)**

9 - 3 or HP = 4 x 110 = 440

HP = highest number of independent claims paid for, if greater than 3.

**3. APPLICATION SIZE FEE**

If the specification and drawings exceed 100 sheets of paper (excluding electronically filed sequence or computer listings under 37 CFR 1.52(e)), the application size fee due is \$270 (\$135 for small entity) for each additional 50 sheets or fraction thereof. See 35 U.S.C. 41(a)(1)(G) and 37 CFR 1.16(s).

**Total Sheets**      **Extra Sheets**      **Number of each additional 50 or fraction thereof**      **Fee (\$)**      **Fee Paid (\$)**

\_\_\_\_\_ - 100 = \_\_\_\_\_ / 50 = \_\_\_\_\_ (round up to a whole number) x \_\_\_\_\_ = \_\_\_\_\_

**4. OTHER FEE(S)**

Other (e.g., late filing surcharge):	Fees Paid (\$)
Non-English Specification, \$130 fee (no small entity discount)	_____
Other (e.g., late filing surcharge): Extension of Time (\$65); RCE (\$405)	\$470

**SUBMITTED BY**

Signature	/Reena Kuyper/	Registration No. (Attorney/Agent)	33,830	Telephone (310) 247-2860
Name (Print/Type)	Reena Kuyper			Date February 16, 2010

This collection of information is required by 37 CFR 1.136. The information is required to obtain or retain a benefit by the public which is to file (and by the USPTO to process) an application. Confidentiality is governed by 35 U.S.C. 122 and 37 CFR 1.14. This collection is estimated to take 30 minutes to complete, including gathering, preparing, and submitting the completed application form to the USPTO. Time will vary depending upon the individual case. Any comments on the amount of time you require to complete this form and/or suggestions for reducing this burden, should be sent to the Chief Information Officer, U.S. Patent and Trademark Office, U.S. Department of Commerce, P.O. Box 1450, Alexandria, VA 22313-1450. DO NOT SEND FEES OR COMPLETED FORMS TO THIS ADDRESS. SEND TO: Commissioner for Patents, P.O. Box 1450, Alexandria, VA 22313-1450.

If you need assistance in completing the form, call 1-800-PTO-9199 and select option 2.

Under the Paperwork Reduction Act of 1995, no persons are required to respond to a collection of information unless it displays a valid OMB control number.

<b>PATENT APPLICATION FEE DETERMINATION RECORD</b> Substitute for Form PTO-875					Application or Docket Number <b>11/948,965</b>		Filing Date <b>11/30/2007</b>		<input type="checkbox"/> To be Mailed										
<b>APPLICATION AS FILED – PART I</b>																			
(Column 1)			(Column 2)			SMALL ENTITY <input checked="" type="checkbox"/>		OR			OTHER THAN SMALL ENTITY								
FOR		NUMBER FILED		NUMBER EXTRA		RATE (\$)		FEE (\$)		RATE (\$)		FEE (\$)							
<input type="checkbox"/> BASIC FEE <small>(37 CFR 1.16(a), (b), or (c))</small>		N/A		N/A		N/A				N/A									
<input type="checkbox"/> SEARCH FEE <small>(37 CFR 1.16(k), (l), or (m))</small>		N/A		N/A		N/A				N/A									
<input type="checkbox"/> EXAMINATION FEE <small>(37 CFR 1.16(o), (p), or (q))</small>		N/A		N/A		N/A				N/A									
TOTAL CLAIMS <small>(37 CFR 1.16(i))</small>		minus 20 =		*		X \$ =				OR		X \$ =							
INDEPENDENT CLAIMS <small>(37 CFR 1.16(h))</small>		minus 3 =		*		X \$ =				OR		X \$ =							
<input type="checkbox"/> APPLICATION SIZE FEE <small>(37 CFR 1.16(s))</small>		If the specification and drawings exceed 100 sheets of paper, the application size fee due is \$250 (\$125 for small entity) for each additional 50 sheets or fraction thereof. See 35 U.S.C. 41(a)(1)(G) and 37 CFR 1.16(s).																	
<input type="checkbox"/> MULTIPLE DEPENDENT CLAIM PRESENT <small>(37 CFR 1.16(j))</small>																			
* If the difference in column 1 is less than zero, enter "0" in column 2.																			
<b>APPLICATION AS AMENDED – PART II</b>																			
(Column 1)			(Column 2)			(Column 3)			SMALL ENTITY		OR		OTHER THAN SMALL ENTITY						
AMENDMENT	<b>02/22/2010</b>		CLAIMS REMAINING AFTER AMENDMENT				HIGHEST NUMBER PREVIOUSLY PAID FOR		PRESENT EXTRA		RATE (\$)		ADDITIONAL FEE (\$)		RATE (\$)		ADDITIONAL FEE (\$)		
	Total <small>(37 CFR 1.16(o))</small>		* 46		Minus		** 20		= 26		X \$26 =		676		OR		X \$ =		
	Independent <small>(37 CFR 1.16(h))</small>		* 10		Minus		***5		= 5		X \$110 =		550		OR		X \$ =		
	<input type="checkbox"/> Application Size Fee <small>(37 CFR 1.16(s))</small>																		
	<input type="checkbox"/> FIRST PRESENTATION OF MULTIPLE DEPENDENT CLAIM <small>(37 CFR 1.16(j))</small>																		
TOTAL ADD'L FEE												<b>1226</b>		OR		TOTAL ADD'L FEE			
AMENDMENT			CLAIMS REMAINING AFTER AMENDMENT				HIGHEST NUMBER PREVIOUSLY PAID FOR		PRESENT EXTRA		RATE (\$)		ADDITIONAL FEE (\$)		RATE (\$)		ADDITIONAL FEE (\$)		
	Total <small>(37 CFR 1.16(o))</small>		*		Minus		**		=		X \$ =				OR		X \$ =		
	Independent <small>(37 CFR 1.16(h))</small>		*		Minus		***		=		X \$ =				OR		X \$ =		
	<input type="checkbox"/> Application Size Fee <small>(37 CFR 1.16(s))</small>																		
	<input type="checkbox"/> FIRST PRESENTATION OF MULTIPLE DEPENDENT CLAIM <small>(37 CFR 1.16(j))</small>																		
TOTAL ADD'L FEE												OR		TOTAL ADD'L FEE					
* If the entry in column 1 is less than the entry in column 2, write "0" in column 3.																			
** If the "Highest Number Previously Paid For" IN THIS SPACE is less than 20, enter "20".																			
*** If the "Highest Number Previously Paid For" IN THIS SPACE is less than 3, enter "3".																			
The "Highest Number Previously Paid For" (Total or Independent) is the highest number found in the appropriate box in column 1.																			
Legal Instrument Examiner: /KIMBERLY PANNELL/																			

This collection of information is required by 37 CFR 1.16. The information is required to obtain or retain a benefit by the public which is to file (and by the USPTO to process) an application. Confidentiality is governed by 35 U.S.C. 122 and 37 CFR 1.14. This collection is estimated to take 12 minutes to complete, including gathering, preparing, and submitting the completed application form to the USPTO. Time will vary depending upon the individual case. Any comments on the amount of time you require to complete this form and/or suggestions for reducing this burden, should be sent to the Chief Information Officer, U.S. Patent and Trademark Office, U.S. Department of Commerce, P.O. Box 1450, Alexandria, VA 22313-1450. DO NOT SEND FEES OR COMPLETED FORMS TO THIS ADDRESS. SEND TO: Commissioner for Patents, P.O. Box 1450, Alexandria, VA 22313-1450.

If you need assistance in completing the form, call 1-800-PTO-9199 and select option 2.

<b>FORM PTO-1449</b>  <b>LIST OF PATENTS AND OTHER ITEMS FOR APPLICANT'S INFORMATION DISCLOSURE STATEMENT</b>  (Use several sheets if necessary)	<b>ATTY. DOCKET NO.</b> TLM-103C1DIV	<b>SERIAL NO.</b> 11/948,965
	<b>APPLICANT:</b> Samuel F. WOOD, et al.	
	<b>FILING DATE:</b> November 30, 2007	<b>GROUP:</b> 2614

U.S. PATENT DOCUMENTS							
EXAMINER INITIAL		DOCUMENT NUMBER	DATE	NAME	CLASS	SUB CLASS	FILING DATE
		2001/0022784	09-2001	Menon et al.	-----	-----	-----
		2001/0030950	10-2001	Chen et al.	-----	-----	-----
		4,313,035	01-1982	Jordan et al.	-----	-----	-----
		4,348,554	09-1982	Asmuth	-----	-----	-----
		4,611,094	09-1986	Asmuth et al.	-----	-----	-----
		4,611,096	09-1986	Asmuth et al.	-----	-----	-----
		4,953,198	08-1990	Daly et al.	-----	-----	-----
		4,973,837	11-1990	Bradbeer	-----	-----	-----
		5,297,191	03-1994	Gerszberg	-----	-----	-----
		5,311,582	05-1994	Davenport et al.	-----	-----	-----
		5,428,663	06-1995	Grimes et al.	-----	-----	-----
		5,448,623	09-1995	Wiedeman et al.	-----	-----	-----
		5,455,853	10-1995	Cebulka et al.	-----	-----	-----
		5,471,616	11-1995	Johnson et al.	-----	-----	-----
		5,495,567	02-1996	Iizawa et al.	-----	-----	-----
		5,497,339	03-1996	Bernard	-----	-----	-----
		5,557,658	09-1996	Gregorek et al.	-----	-----	-----
		5,563,937	10-1996	Bruno et al.	-----	-----	-----
		5,606,594	02-1997	Register et al.	-----	-----	-----
		5,628,004	051997	Gormley et al.	-----	-----	-----
		5,646,945	07-1997	Bergler	-----	-----	-----
		5,727,057	03-1998	Emery et al.	-----	-----	-----

<b>EXAMINER:</b>	<b>DATE CONSIDERED:</b>
EXAMINER: Initial if reference is considered, whether or not citation is in conformance with MPEP 609; Draw line through citation if not in conformance and not considered. Include a copy of this form with next communication to applicant	



<b>FORM PTO-1449</b>  <b>LIST OF PATENTS AND OTHER ITEMS FOR APPLICANT'S INFORMATION DISCLOSURE STATEMENT</b>  (Use several sheets if necessary)	<b>ATTY. DOCKET NO.</b> TLM-103C1DIV	<b>SERIAL NO.</b> 11/948,965
	<b>APPLICANT:</b> Samuel F. WOOD, et al.	
	<b>FILING DATE:</b> November 30, 2007	<b>GROUP:</b> 2614

U.S. PATENT DOCUMENTS							
EXAMINER INITIAL		DOCUMENT NUMBER	DATE	NAME	CLASS	SUB CLASS	FILING DATE
		5,727,057	03-1998	Emery et al.	-----	-----	-----
		5,732,074	03-1998	Spaur et al.	-----	-----	-----
		5,732,216	03-1998	Logan et al.	-----	-----	-----
		5,737,533	04-1998	De Hond	-----	-----	-----
		5,742,905	04-1998	Pepe et al.	-----	-----	-----
		5,806,057	09-1998	Gormley et al.	-----	-----	-----
		5,838,665	11-1998	Kahn et al.	-----	-----	-----
		5,850,433	12-1998	Rondeau	-----	-----	-----
		5,859,972	01-1999	Subramaniam et al.	-----	-----	-----
		5,875,405	02-1999	Honda	-----	-----	-----
		5,878,418	03-1999	Polcyn et al.	-----	-----	-----
		5,894,473	04-1999	Dent	-----	-----	-----
		5,894,595	04-1999	Foladare et al.	-----	-----	-----
		5,913,029	06-1999	Shostak	-----	-----	-----
		5,915,008	06-1999	Dulman	-----	-----	-----
		5,918,172	06-1999	Saunders et al.	-----	-----	-----
		5,930,700	07-1999	Pepper et al.	-----	-----	-----
		5,933,778	08-1999	Buhrmann et al.	-----	-----	-----
		5,938,757	08-1999	Bertsch	-----	-----	-----
		5,960,340	09-1999	Fuentes	-----	-----	-----
		5,970,059	10-1999	Ahopelto et al.	-----	-----	-----
		5,991,394	11-1999	Dezonno et al.	-----	-----	-----

<b>EXAMINER:</b>	<b>DATE CONSIDERED:</b>
EXAMINER: Initial if reference is considered, whether or not citation is in conformance with MPEP 609; Draw line through citation if not in conformance and not considered. Include a copy of this form with next communication to applicant	

<b>FORM PTO-1449</b>  <b>LIST OF PATENTS AND OTHER ITEMS FOR APPLICANT'S INFORMATION DISCLOSURE STATEMENT</b>  (Use several sheets if necessary)	<b>ATTY. DOCKET NO.</b> TLM-103C1DIV	<b>SERIAL NO.</b> 11/948,965
	<b>APPLICANT:</b> Samuel F. WOOD, et al.	
	<b>FILING DATE:</b> November 30, 2007	<b>GROUP:</b> 2614

U.S. PATENT DOCUMENTS							
EXAMINER INITIAL		DOCUMENT NUMBER	DATE	NAME	CLASS	SUB CLASS	FILING DATE
		6,006,272	12-1999	Aravamudan et al.	-----	-----	-----
		6,014,437	01-2000	Acker et al.	-----	-----	-----
		6,020,916	02-2000	Gerszberg et al.	-----	-----	-----
		6,028,917	02-2000	Creamer et al.	-----	-----	-----
		6,031,904	02-2000	An et al.	-----	-----	-----
		6,044,403	03-2000	Gerszberg et al.	-----	-----	-----
		6,075,992	06-2000	Moon et al.	-----	-----	-----
		6,078,581	06-2000	Shtivelman et al.	-----	-----	-----
		6,084,584	07-2000	Nahi et al.	-----	-----	-----
		6,094,478	07-2000	Shepherd et al.	-----	-----	-----
		6,104,800	08-2000	Benson	-----	-----	-----
		6,141,341	10-2000	Jones et al.	-----	-----	-----
		6,161,134	12-2000	Wang et al.	-----	-----	-----
		6,163,598	12-2000	Moore	-----	-----	-----
		6,167,040	12-2000	Haeggstrom	-----	-----	-----
		6,175,860	01-2001	Gaucher	-----	-----	-----
		6,188,688	02-2001	Buskirk, Jr.	-----	-----	-----
		6,212,261	04-2001	Meubus et al.	-----	-----	-----
		6,216,158	04-2001	Luo et al.	-----	-----	-----
		6,240,097	05-2001	Wesloek et al.	-----	-----	-----
		6,259,692	07-2001	Shtivelman et al.	-----	-----	-----
		6,262,978	07-2001	Bruno et al.	-----	-----	-----

<b>EXAMINER:</b>	<b>DATE CONSIDERED:</b>
EXAMINER: Initial if reference is considered, whether or not citation is in conformance with MPEP 609; Draw line through citation if not in conformance and not considered. Include a copy of this form with next communication to applicant	

<b>FORM PTO-1449</b>  <b>LIST OF PATENTS AND OTHER ITEMS FOR APPLICANT'S INFORMATION DISCLOSURE STATEMENT</b>  (Use several sheets if necessary)	<b>ATTY. DOCKET NO.</b> TLM-103C1DIV	<b>SERIAL NO.</b> 11/948,965
	<b>APPLICANT:</b> Samuel F. WOOD, et al.	
	<b>FILING DATE:</b> November 30, 2007	<b>GROUP:</b> 2614

U.S. PATENT DOCUMENTS							
EXAMINER INITIAL		DOCUMENT NUMBER	DATE	NAME	CLASS	SUB CLASS	FILING DATE
		6,266,539	07-2001	Pardo	-----	-----	-----
		6,301,609	10-2001	Aravamudan et al.	-----	-----	-----
		6,308,201	10-2001	Pivowar et al.	-----	-----	-----
		6,334,126	12-2001	Nagatomo et al.	-----	-----	-----
		6,337,858	01-2002	Petty et al.	-----	-----	-----
		6,359,892	03-2002	Szlam et al.	-----	-----	-----
		6,385,308	05-2002	Cohen et al.	-----	-----	-----
		6,404,764	06-2002	Jones et al.	-----	-----	-----
		6,411,615	06-2002	DeGolia et al.	-----	-----	-----
		6,411,965	06-2002	Klug	-----	-----	-----
		6,414,962	07-2002	Hall et al.	-----	-----	-----
		6,418,198	07-2002	Brablec et al.	-----	-----	-----
		6,421,235	07-2002	Ditzik	-----	-----	-----
		6,445,694	09-2002	Swartz	-----	-----	-----
		6,445,697	09-2002	Fenton	-----	-----	-----
		6,446,127	09-2002	Shuster et al.	-----	-----	-----
		6,448,978	09-2002	Salvador et al.	-----	-----	-----
		6,456,594	09-2002	Kaplan et al.	-----	-----	-----
		6,456,601	09-2002	Kozdon et al.	-----	-----	-----
		6,477,565	11-2002	Daswani et al.	-----	-----	-----
		6,477,576	11-2002	Angwin et al.	-----	-----	-----
		6,483,902	11-2002	Stewart et al.	-----	-----	-----

<b>EXAMINER:</b>	<b>DATE CONSIDERED:</b>
EXAMINER: Initial if reference is considered, whether or not citation is in conformance with MPEP 609; Draw line through citation if not in conformance and not considered. Include a copy of this form with next communication to applicant	

<b>FORM PTO-1449</b>  <b>LIST OF PATENTS AND OTHER ITEMS FOR APPLICANT'S INFORMATION DISCLOSURE STATEMENT</b>  (Use several sheets if necessary)	<b>ATTY. DOCKET NO.</b> TLM-103C1DIV	<b>SERIAL NO.</b> 11/948,965
	<b>APPLICANT:</b> Samuel F. WOOD, et al.	
	<b>FILING DATE:</b> November 30, 2007	<b>GROUP:</b> 2614

U.S. PATENT DOCUMENTS							
EXAMINER INITIAL		DOCUMENT NUMBER	DATE	NAME	CLASS	SUB CLASS	FILING DATE
		6,493,338	12-2002	Preston et al.	-----	-----	-----
		6,496,477	12-2002	Perkins et al.	-----	-----	-----
		6,526,462	02-2003	Elabd	-----	-----	-----
		6,539,359	03-2003	Ladd et al.	-----	-----	-----
		6,577,622	06-2003	Shuster et al.	-----	-----	-----
		6,584,490	06-2003	Shuster et al.	-----	-----	-----
		6,650,901	11-2003	Shuster et al.	-----	-----	-----
		6,681,252	01-2004	Shuster et al.	-----	-----	-----
		6,731,630	05-2004	Shuster et al.	-----	-----	-----
		6,741,586	05-2004	Shuster et al.	-----	-----	-----
		6,785,266	08-2004	Swartz	-----	-----	-----
		6,795,429	09-2004	Shuster et al.	-----	-----	-----
		6,804,224	10-2004	Shuster et al.	-----	-----	-----
		6,822,957	11-2004	Shuster et al.	-----	-----	-----
		6,853,714	02-2005	Liljestrand et al.	-----	-----	-----
		6,856,616	02-2005	Shuster et al.	-----	-----	-----
		6,857,021	02-2005	Shuster et al.	-----	-----	-----
		6,857,072	02-2005	Shuster et al.	-----	-----	-----
		6,870,830	03-2005	Shuster et al.	-----	-----	-----
		6,914,897	07-2005	Shuster et al.	-----	-----	-----
		6,937,699	08-2005	Shuster et al.	-----	-----	-----

<b>EXAMINER:</b>	<b>DATE CONSIDERED:</b>
EXAMINER: Initial if reference is considered, whether or not citation is in conformance with MPEP 609; Draw line through citation if not in conformance and not considered. Include a copy of this form with next communication to applicant	

<b>FORM PTO-1449</b>  <b>LIST OF PATENTS AND OTHER ITEMS FOR APPLICANT'S INFORMATION DISCLOSURE STATEMENT</b>  (Use several sheets if necessary)	<b>ATTY. DOCKET NO.</b> TLM-103C1DIV	<b>SERIAL NO.</b> 11/948,965
	<b>APPLICANT:</b> Samuel F. WOOD, et al.	
	<b>FILING DATE:</b> November 30, 2007	<b>GROUP:</b> 2614

FOREIGN PATENT DOCUMENTS								
EXAMINER INITIAL		DOCUMENT NUMBER	DATE	COUNTRY	CLASS	SUB CLASS	TRANSLATI YE	NO
		DE19813179	09-1999	DE	-----	-----	X	
		EP0578374	01-1994	EP	-----	-----		
		EP0704788	04-1996	EP	-----	-----		
		EP0858202	08-1998	EP	-----	-----		
		EP0869688	10-1998	EP	-----	-----		
		EP0881848	12-1998	EP	-----	-----		
		EP0918423	10-1998	EP	-----	-----		
		WO01/024496	04-2001	WO	-----	-----		
		WO01/024498	04-2001	WO	-----	-----		
		WO01/024500	04-2001	WO	-----	-----		
		WO01/024501	04-2001	WO	-----	-----		
		WO01/024502	04-2001	WO	-----	-----		
		WO01/024503	04-2001	WO	-----	-----		
		WO01/05078	01-2001	WO	-----	-----		
		WO94/05111	03-1994	WO	-----	-----		
		WO95/34985	12-1995	WO	-----	-----		
		WO97/31492	08-1997	WO	-----	-----		
		WO97/33421	09-1997	WO	-----	-----		
		WO97/44943	11-1997	WO	-----	-----		
		WO98/00988	01-1998	WO	-----	-----		
		WO98/04065	01-1998	WO	-----	-----		
		WO98/10538	03-1998	WO	-----	-----		

<b>EXAMINER:</b>	<b>DATE CONSIDERED:</b>
EXAMINER: Initial if reference is considered, whether or not citation is in conformance with MPEP 609; Draw line through citation if not in conformance and not considered. Include a copy of this form with next communication to applicant	

<b>FORM PTO-1449</b>  <b>LIST OF PATENTS AND OTHER ITEMS FOR APPLICANT'S INFORMATION DISCLOSURE STATEMENT</b>  (Use several sheets if necessary)	<b>ATTY. DOCKET NO.</b> TLM-103C1DIV	<b>SERIAL NO.</b> 11/948,965
	<b>APPLICANT:</b> Samuel F. WOOD, et al.	
	<b>FILING DATE:</b> November 30, 2007	<b>GROUP:</b> 2614

FOREIGN PATENT DOCUMENTS								
EXAMINER INITIAL		DOCUMENT NUMBER	DATE	COUNTRY	CLASS	SUB CLASS	TRANSLATION NO	
		WO98/16051	04-1998	WO	-----	-----		
		WO98/21911	05-1998	WO	-----	-----		
		WO98/30008	07-1998	WO	-----	-----		
		WO98/37665	08-1998	WO	-----	-----		
		WO99/12365	03-1999	WO	-----	-----		
		WO99/19988	04-1999	WO	-----	-----		
		WO99/20059	04-1999	WO	-----	-----		
		WO99/35802	07-1999	WO	-----	-----		
		WO99/45687	09-1999	WO	-----	-----		

OTHER DOCUMENTS (Including Author, Title, Date, Pertinent Pages, etc.)		
EXAMINER INITIAL		
	1	RFC 3298 Service in the PSTN, August 2002
	2	Implementing Automatic Location Update for Follow-Me database using VoIP and Bluetooth Technologies, IEEE Transaction on computers, Vol. 51, No. 10, October 2002
	3	New services demand integration, Electronic Engineering Times, Aug. 28, 2000, Iss. 1128; pg. 110
	4	Natural Microsystems, M2 Presswire. Coventry: Aug, 18, 2000
	5	This pipe dream will come true: Voice Over Internet Protocol (VoIP) technology will make the phone Box something that really talks, Businessline, Chennai: Apr 17, 2002
	6	Using Optimization to Achieve Efficient Quality of Service in Voice over IP Networks, IEEE 2003
	7	Broadsoft literature Broadworks overview, Copyright date 2002
	8	BroadSoft introduces industry's first complete service delivery and creation product suite for enhanced telephony services Broadworks, ATM Newsletter: Boston: March 2000, vol. 9, Iss. 3, pg 13
	9	BroadSoft unveils advanced architecture for the rapid and cost effective delivery of enhanced communications services, Website, August 25, 1999, Press releases, 3 pages.
	10	U.S. patent application Ser. No. 09/406,322, Schuster et al., filed Sep. 27, 1999
	11	U.S. patent application Ser. No. 09/515,798, Schuster et al., filed Feb. 29, 2000

<b>EXAMINER:</b>	<b>DATE CONSIDERED:</b>
EXAMINER: Initial if reference is considered, whether or not citation is in conformance with MPEP 609; Draw line through citation if not in conformance and not considered. Include a copy of this form with next communication to applicant	

<b>FORM PTO-1449</b>  <b>LIST OF PATENTS AND OTHER ITEMS FOR APPLICANT'S  INFORMATION DISCLOSURE STATEMENT</b>  (Use several sheets if necessary)	<b>ATTY. DOCKET NO.</b> TLM-103C1DIV	<b>SERIAL NO.</b> 11/948,965
	<b>APPLICANT:</b> Samuel F. WOOD, et al.	
	<b>FILING DATE:</b> November 30, 2007	<b>GROUP:</b> 2614

<b>EXAMINER:</b>	<b>DATE CONSIDERED:</b>
EXAMINER: Initial if reference is considered, whether or not citation is in conformance with MPEP 609; Draw line through citation if not in conformance and not considered. Include a copy of this form with next communication to applicant	

No active trail

**DELPHION**

Select OK

RESEARCH PRODUCTS INSIDE DELPHION

Log Out Work Files Saved Searches

My Account

Search: Quick/Number Boolean Advanced Derwent Help

**Derwent Record**

Email this to a friend

View: Expand Details Go to: Delphion Integrated View Tools: Add to Work File: Create new Work File Add

Derwent Title: **Internet-telephone with telephone acting as client for Internet applications - allows carrying out entries via telephone using telephone's keypad, microphone and loudspeaker and allows functionality extension of telephone using additional memories and processors**

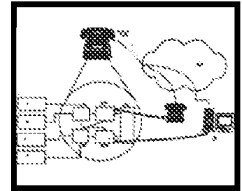
Original Title:  DE19813179A1: Internet-telephone with telephone acting as client for Internet applications

Assignee: **SIEMENS AG** Standard company  
Other publications from [SIEMENS AG \(SIEI\)...](#)

Inventor: **VAN DER VEKENS A;**

Accession/Update: **1999-541738 / 199948**

IPC Code: **H04M 1/00 ; H04L 12/16 ; H04M 1/21 ;**



Derwent Classes: **T01; W01;**

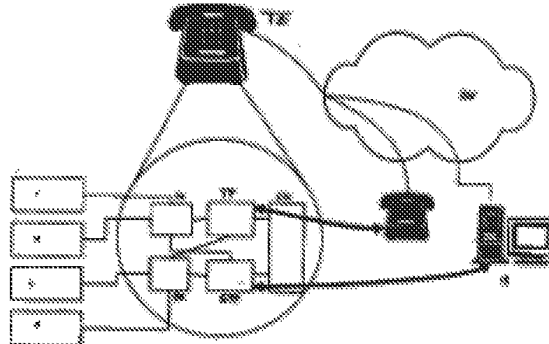
Manual Codes: **T01-J08C**(Communication controller) , **W01-A06**(Exchanges; connections between exchanges (including LAN)) , **W01-A06B7**(Internet and intranet) , **W01-C01**(Subscriber equipment) , **W01-C01A**(Construction (including cradle switch mechanical aspects)) , **W01-C05B5**(Entertainment, dictation)

Derwent Abstract: (DE19813179A) The Internet-telephone includes a telephone which has an electronic memory and a processor. Entries can be carried out via the telephone using the keypad, microphone and loudspeaker.

The telephone can be extended in its functionality using additional memories and processors so that the telephone can act as a client for Internet applications. Preferably, the a connection set-up to the Internet can be controlled using the telephone. Applet software can be loaded to the telephone via the Internet.

**Advantage** - Allows reduction of terminals and integration of computer function into telephone.

Images:



Dwg.1/1

Family:	PDF Patent	Pub. Date	Derwent Update	Pages	Language	IPC Code
<input checked="" type="checkbox"/>	DE19813179A1 *	1999-09-30	199946	3	German	H04M 1/00
Local apps.: DE1998001013179 Filed:1998-03-25 (98DE-1013179)						

INPADOC Legal Status: [Show legal status actions](#)

First Claim: [Show all claims](#) 1. Internet-Telefon, mit einem Telefon, das einen elektronischen Speicher sowie einen Prozessor aufweist und über das Eingaben mittels Tastatur, Mikrofon und Lautsprecher vorgenommen werden



können, **dadurch gekennzeichnet**, daß das Telefon in seiner Funktionalität derart erweitert wird, daß es als Client für Internet Anwendungen verwendbar ist.

Priority Number:

Application Number	Filed	Original Title
DE1998001013179	1998-03-25	

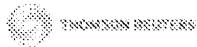
Title Terms:

TELEPHONE TELEPHONE ACT CLIENT APPLY ALLOW CARRY ENTER TELEPHONE  
TELEPHONE MICROPHONE LOUDSPEAKER ALLOW FUNCTION EXTEND TELEPHONE ADD  
MEMORY PROCESSOR

[Pricing](#) [Current charges](#)

<b>Derwent Searches:</b>	<a href="#">Boolean</a>   <a href="#">Accession/Number</a>   <a href="#">Advanced</a>
--------------------------	---

Data copyright Thomson Derwent 2003



Copyright © 1997-2010 Thomson Reuters

[Subscriptions](#) | [Web Seminars](#) | [Privacy](#) | [Terms & Conditions](#) | [Site Map](#) | [Contact Us](#) | [Help](#)



19 **BUNDESREPUBLIK  
DEUTSCHLAND**



**DEUTSCHES  
PATENT- UND  
MARKENAMT**

12 **Offenlegungsschrift**  
10 **DE 198 13 179 A 1**

51 Int. Cl.<sup>6</sup>:  
**H 04 M 1/00**  
H 04 M 1/21  
H 04 L 12/16

21 Aktenzeichen: 198 13 179.8  
22 Anmeldetag: 25. 3. 98  
43 Offenlegungstag: 30. 9. 99

**DE 198 13 179 A 1**

71 Anmelder:  
Siemens AG, 80333 München, DE

72 Erfinder:  
Vekens, Alexander van der, Dipl.-Inform., 81373  
München, DE

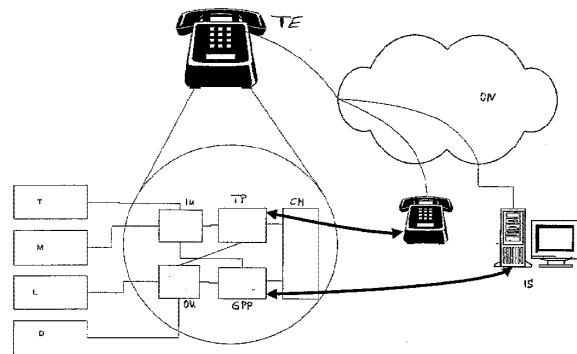
56 Entgegenhaltungen:  
DE 196 45 368 A1  
WO 97 19 519 A2  
WO 91 07 839 A1

**Die folgenden Angaben sind den vom Anmelder eingereichten Unterlagen entnommen**

Prüfungsantrag gem. § 44 PatG ist gestellt

54 Internet-Telefon

57 Gegenwärtige als Endgerät ausgebildete Telefone weisen in der Regel keine oder nur minimale Intelligenz auf. Damit können diese Endgeräte nur eingeschränkt für moderne Internetdienste verwendet werden. Um eine Verwendung hier dennoch sinnvoll vornehmen zu können, wird erfindungsgemäß vorgesehen, das Telefon mit zusätzlichen Speicher- und Prozessormitteln zu erweitern. Damit sind dann komplexe Funktionen, die bislang in PCs integriert sind, im Telefon selbst ablauffähig. Damit ist ein derartiges Telefon als intelligentes Endgerät für Internetdienste verwendbar.



**DE 198 13 179 A 1**

## Beschreibung

Die Erfindung betrifft eine Vorrichtung gemäß dem Oberbegriff von Patentanspruch 1.

Zeitgemäße Endgeräte werden zunehmend als digitale Telefone ausgebildet. Derartige Endgeräte weisen in der Regel keinerlei oder wenig Intelligenz auf und werden parallel zu den modernen Internetdiensten oder zukünftigen Intelligenzen Netzdiensten (wie z. B. TINA) zugeordneten Endgeräten wie Personal Computer, Netzwerkcomputer oder Set-Top-Boxen betrieben. Damit steigt die Zahl der Endgeräte im privaten wie öffentlichen Hausbereich je nach Verwendung jener Netze sowie die zugeordneten Dienste um ein Vielfaches.

Damit ist nicht nur die Komplexität in der Bedienung aller Endgeräte gewachsen, auch unter Kostenaspekten ist eine derartige Vielzahl für den Anwender unwirtschaftlich. Letzteres gilt auch für die Hersteller, die bezüglich Lagerhaltung und Ersatzteile besondere Vorkehrungen treffen müssen.

Der Erfindung liegt die Aufgabe zugrunde, einen Weg aufzuzeigen, wie die Vielzahl der Endgeräte verringert werden kann. Vorteilhaft an der Erfindung ist insbesondere das Integrieren von Personal Computer-Funktionen in das Telefon. Insbesondere Personal Computer weisen aufgrund ihrer Prozessoren und Speichermittel eine umfangreiche Funktionalität auf.

Vorteilhafte Weiterbildungen der Erfindung sind in den Unteransprüchen angegeben.

Die Erfindung wird im folgenden anhand eines figurlich dargestellten Ausführungsbeispiels näher erläutert.

In der Figur ist die erfindungsgemäße Vorrichtung offenbart. Demgemäß ist vorgesehen, ein digitales Telefon TE als Basiseinheit zu verwenden. Derartige digitale Telefone weisen heute einen Zentralprozessor sowie einen entsprechenden elektronischen Speicher auf.

Es wird vorgesehen, das Telefon TE gegebenenfalls um weitere Prozessoren und Speicher derart zu erweitern, daß auch komplexere Funktionen, die gegenwärtig in Personal Computern ablaufen, in derart erweiterten Telefonen ablauf-fähig sind. Als Funktionen sind beispielhaft Verbindungsaufbaueinrichtungen CM (Connection Management) vorgesehen. Weiterhin sind Telefonprozeduren TP (Telephony Processing) vorgesehen. Diese stellen die Funktionalität des Telefons TE als herkömmliches Telefon sicher. Die komplexen Funktionen sind in der Einrichtung GPP realisiert. Als Schnittstelle zum Anwender sind Ein-/Ausgabeeinrichtungen IU, OU vorgesehen. Die Kommunikation zwischen Anwender und Telefon erfolgt über eine Tastatur T, ein Mikrofon M, Lautsprechereinrichtungen L sowie Anzeigevorrichtungen D.

Im folgenden wird die Funktionsweise eines derart ausgebildeten Telefons TE aufgezeigt:

Demgemäß soll beispielsweise Software über ein Netz, das beispielhaft als öffentliches Netz ON ausgebildet sein kann, in das Telefon TE geladen werden. Damit soll es möglich sein, eine Kommunikation zwischen dieser Software und dem Anwender zu steuern. Der zugeordnete Dienst soll aber auf einem Server ausgeführt werden. Dabei findet eine weitere Kommunikation zwischen der im Telefon TE geladenen Software und diesem Dienst über das Netz statt. Beispielfhaft sollen akustische JAVA Applets für diese Aufgabe verwendet werden. Damit wird ein herkömmliches digitales Telefon bezüglich seiner Funktionalität erheblich erweitert.

Hierzu wird ein Verbindungsaufbau vom Telefon TE über das öffentliche Netz ON zu einem Internet-Server IS durchgeführt. Die Steuerungsvorgänge werden von der im Telefon TE angeordneten Verbindungsaufbaueinrichtung CM

vorgenommen und überwacht. Die hierzu erforderlichen Eingaben werden vom Anwender unter Benutzung herkömmlicher Einrichtungen T, M, L, D vorgenommen. Als systeminterne Schnittstellen fungieren die Ein-/Ausgabeeinrichtungen IU, OU. Ist die Verbindung erstellt, wird die Applet Software über die aufgebaute Verbindung in die elektronischen Speicher des Telefons TE in die Einrichtung GPP geladen. Damit ist dann ein Datenaustausch zwischen dem Internet-Server IS und der Applet Software möglich. Zeitgleich hierzu kann eine weitere Kommunikation zwischen Anwender und der Applet Software durchgeführt werden.

## Patentansprüche

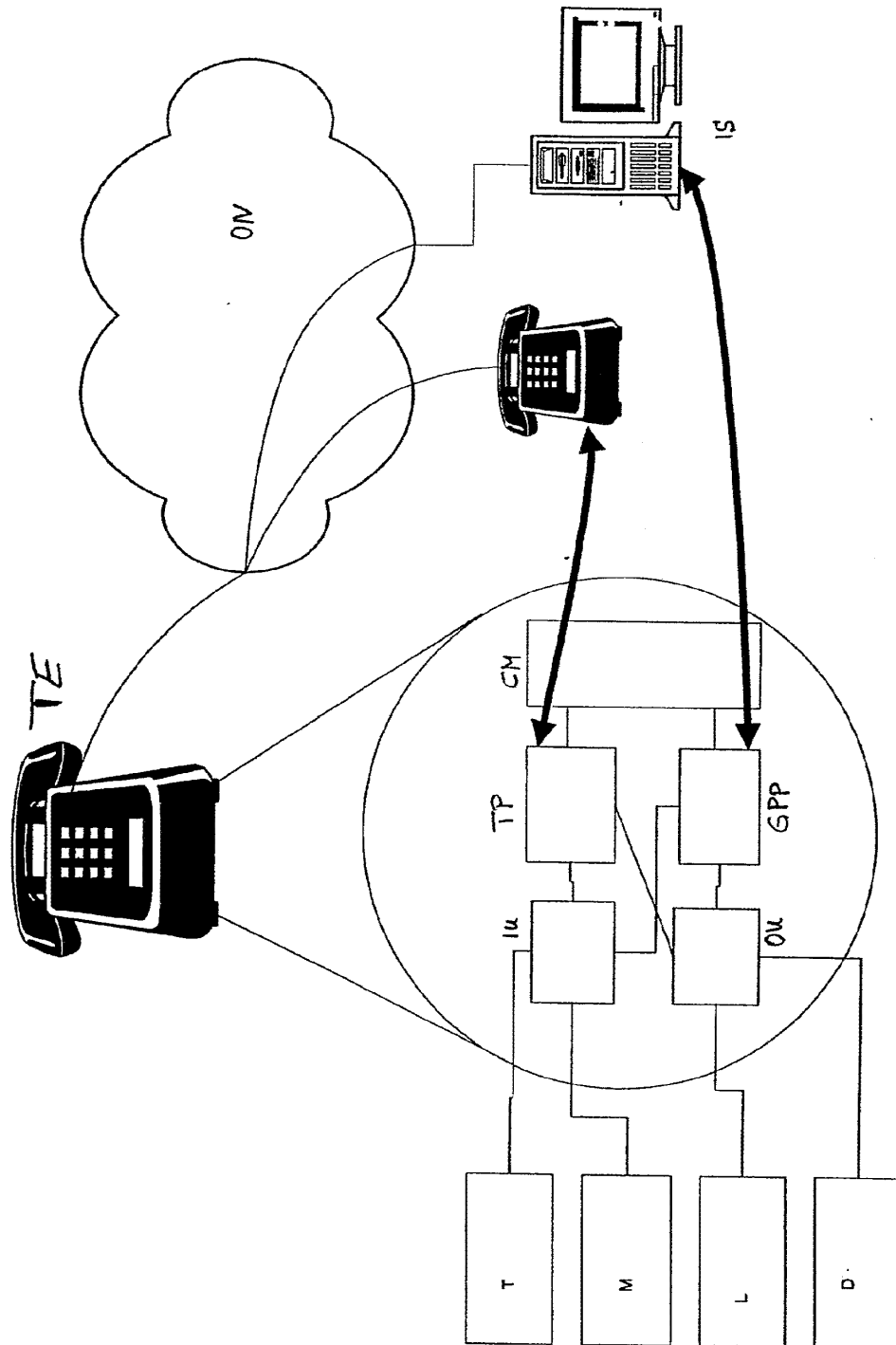
1. Internet-Telefon, mit einem Telefon, das einen elektronischen Speicher sowie einen Prozessor aufweist und über die Eingaben mittels Tastatur, Mikrofon und Lautsprecher vorgenommen werden können, **dadurch gekennzeichnet**, daß das Telefon in seiner Funktionalität derart erweitert wird, daß es als Client für Internet Anwendungen verwendbar ist.
2. Internet-Telefon nach Anspruch 1, dadurch gekennzeichnet, daß mit dem Telefon ein Verbindungsaufbau zum Internet steuerbar ist.
3. Internet-Telefon nach Anspruch 1 oder 2, dadurch gekennzeichnet, daß Applet Software über das Internet in das Telefon ladbar ist.

---

Hierzu 1 Seite(n) Zeichnungen

---

- Leerseite -



FIGUR

902 039/455

(19)



Europäisches Patentamt  
European Patent Office  
Office européen des brevets



(11) EP 0 578 374 B1

(12)

**EUROPEAN PATENT SPECIFICATION**

(45) Date of publication and mention of the grant of the patent:  
**02.12.1998 Bulletin 1998/49**

(51) Int Cl.<sup>6</sup>: **H04M 11/00, H04M 3/42, G07C 9/00, G08B 3/10**

(21) Application number: **93304446.3**

(22) Date of filing: **08.06.1993**

**(54) Method and apparatus for providing a personal locator, access control and asset tracking service using an in-building telephone network**

Verfahren und Einrichtung zur Personenaufenthaltsbestimmung, Zugangskontrolle und Güteraufspürung mit dem Telefonnetz eines Gebäudes

Méthode et dispositif pour assurer les services de localisation de personnes , contrôle d'accès et pistage de matériels en utilisant le réseau téléphonique d'un immeuble

(84) Designated Contracting States:  
**DE FR GB SE**

(30) Priority: **29.06.1992 US 906192**

(43) Date of publication of application:  
**12.01.1994 Bulletin 1994/02**

(73) Proprietor: **NORTHERN TELECOM LIMITED  
Montreal, Quebec H2Y 3Y4 (CA)**

(72) Inventors:  
• **Mufti, Sohale Aziz  
Kanata, Ontario K2M 2A3 (CA)**  
• **Yip, Adrian Men-Gee  
Kanata, Ontario K2L 1R7 (CA)**

- **Samuel, Robert George  
Nepean, Ontario K2J 3E4 (CA)**
- **Soong, Peter Pui Kwok  
Nepean, Ontario K2J 5S7 (CA)**
- **Wakim, Michael Jamil  
Nepean, Ontario K2J 1T8 (CA)**

(74) Representative: **Ryan, John Peter William et al  
Nortel Patents,  
London Road  
Harlow, Essex CM17 9NA (GB)**

(56) References cited:  
**EP-A- 0 152 908                      FR-A- 2 630 565**  
**GB-A- 2 222 503                      GB-A- 2 225 141**  
**US-A- 4 752 951**

**EP 0 578 374 B1**

Note: Within nine months from the publication of the mention of the grant of the European patent, any person may give notice to the European Patent Office of opposition to the European patent granted. Notice of opposition shall be filed in a written reasoned statement. It shall not be deemed to have been filed until the opposition fee has been paid. (Art. 99(1) European Patent Convention).

**Description****Field of the Invention**

5 This invention relates to personal communication services and more particularly to systems for providing a locator, access control and asset tracking service whereby users and material assets can be located and access restricted using an in-building telephone network.

**Background of the Invention**

10 A number of personal communication devices have been designed to allow subscribers of the telephone service the opportunity to be reached in the event a calling party is attempting to reach that subscriber. Portable cellular telephones, pagers and cordless telephones are such known devices.

15 Specification No EP-A-0 152 908 describes an arrangement for use in an automatic call transfer system in which users carrying transmitters and moving in a limited area are assigned personal identification numbers for the purpose of directing transferred calls to those users. A PABX incorporating location apparatus for transmitters carried by users is described in specification No GB-A-2 222 503. An arrangement for the electronic location of persons or objects is described in specification No FR-A-2 630 565.

20 Those who do not have access to these devices can currently receive calls at a telephone set other than their own, by providing potential callers their new telephone numbers, call forwarding their calls to a telephone set at their new location, or specifically instructing the network of their new location each time they move to a new location. Similarly, a number of asset tracking systems have been designed to provide a user assistance in tracking material assets. One of the problems associated with the tracking of assets, is that the equipment is often moved from one room to the next as the need arises. Thus, the tracking of expensive equipment within, say, a large laboratory, can be difficult. In addition, 25 a material asset could be removed from the secured premises without detection.

One of the problems associated with the existing locator and asset tracking systems, is that they require the site to be re-wired for installation of infrared or other sensors, which is often done at the expense of the user.

Systems that are designed for locating individuals for the routing of calls, are not useable as an asset tracking system and vice versa.

30 Although some systems provide transmitting devices to be carried by individuals, the user has no control over its use. That is, other than leaving the transmitting device at a specific location, calls will always follow the individual. This can be annoying, especially, if the individual does not want to be disturbed at his or her new location. For example, the individual maybe in a meeting, with others, also wearing the transmitting device.

Another problem is that the ID code sent by the transmitting device is not secure and can easily be replicated.

35 Yet another problem associated with the use of existing systems, is when the individual is located in an area served by multiple telephone terminals. A number of operational and network oriented problems will occur, since several telephone terminals will pick up the same ID code. In addition, in some instances, the terminal picking up the strongest signal from the ID transmitting device will not necessarily be the unit closest to the individual, therefore resulting in confusion.

40 Systems that offer access control currently do not make use of the in-building telephone system to restrict access either into the building or to specific rooms once inside the building.

Thus a need exist for a personal communication system able to automatically locate a user for the purpose of delivering an incoming call to them, which can be used for in-building access control and which can also be used to locate assets in real-time to eliminate physical inventories and loss of valuable assets.

45 Accordingly, there is a need for an improved method and apparatus for providing a locator, access control and asset tracking service whereby users and material assets can be located using an in-building telephone network, while also providing intelligent network services.

50 It is therefore an object of the present invention to provide an improved method and apparatus for operating a personal communication and locator service within a telephone network wherein a transmitting device is provided having means to enable the user to either become automatically or manually registered with the telephone network.

Another object of the present invention is to provide an improved method and apparatus for operating a personal communication and locator service within a telephone network, wherein the transmitting device enables the downloading of the user's service configuration to a specific telephone set.

55 Another object of the present invention is to provide an improved method and apparatus for operating a personal communication and locator service within a telephone network, wherein the transmitting device allows the user to activate and deactivate intelligent network services without having to make use the keypad on the telephone terminal located nearby.

Another object of the present invention is to provide an improved method and apparatus for operating a personal

communication and locator service within a telephone network, wherein access control is provided by making use of the transmitting device to allow the user to enter and exit a facility or room according to the entry level requirements.

Another object of the present invention is to provide an improved method and apparatus for operating a personal communication and locator service within a telephone network, wherein the transmitting device is in the form of an ID badge which can either transmit an autonomous periodic RF signal to a receiving unit located at a nearby telephone terminal or transmit a different RF signal when one or more buttons are depressed.

Another object of the present invention is to provide an improved method and apparatus for operating an asset tracking service using the in-building telephone network.

Another object of the present invention is to provide improved method and apparatus for operating an asset tracking service, wherein a transmitting device is permanently secured to an asset to enable a receiving station, connected to the telephone network, to monitor the location and movement of the asset.

Another object of the present invention is to provide improved method and apparatus for operating an asset tracking service, wherein the transmitting device is provided with means for detecting the removal of the transmitting device from the asset.

### Summary of the Invention

In the first embodiment of the invention, a low-power signal is emitted by a small radio transmitter embedded in a person's identification badge. The transmitter automatically sends out signals, which the system uses to update the person's location. Alternately, the user can manually register his or her new location by pushing a button on the ID badge. This signal is detected by base stations, typically located within the walls of a building or in desktop telephone sets. Upon receiving a signal, the base station communicates over the telephone lines with a telecommunications switch. The switch contains software to locate individuals and redirect their phone calls to the nearest telephone.

The software in the telecommunications switch also enables features that give individuals extensive ability to customize their personal communications to suit individual needs and preferences. For example, an individual can request that the system screens incoming calls, so that only high priority callers are put through. Other calls could be directed to voice mail.

In addition, the individual can also conveniently control the extent to which his or her personal communications services are transferred to a telephone at a new location. A user might want to have only external calls forwarded, or temporarily assign to the nearest phone, all of his or her personal telephony services, such as a speed-dialling directory and called-number display.

Also, the ID badge is designed to restrict or allow access to certain areas of a building, or the building itself.

In a second embodiment of the invention, the system keeps track of the location of critical assets, such as computerized workstations or test equipment. Tags, containing the low-power transmitters are placed on, or inside, the assets. These transmitters emit a signal at designated intervals. If the asset is moved, the signal is detected by the base stations, located within the walls of the building or in desktop telephone sets, pinpoints the new location and sends this information over the telephone lines to a database.

The actual network communication can be accomplished through the use of signal modulation such as the "data above voice" mechanism, or through the use of the "D channel" signalling as defined in the Integrated Services Digital Network (ISDN) Basic Rate Interface (BRI) Q.931 signalling.

The transmitting devices send periodic homing signals to a receiving device located nearby. The information which is sent identifies the badge and any miscellaneous operations associated with the operation of the badge. In the case of asset tracking, the homing signal provides an indication of the type of asset being tracked by the system.

According to a first aspect of the present invention there is provided a system for providing a personal communication and locator service within a telephone network as a subscriber moves along the network from a first receiver device associated with his home telephone set to a second receiver device associated with a visited telephone set, the system comprising:

database storage means (17), for storing a list of subscriber profiles indicative of the identity of the subscriber and network services available to that subscriber at his home telephone set;

transmitter means (50, 51) adapted to be carried by a subscriber, and able to transmit a predetermined radio frequency signal;

input means (62, 63) at said transmitter means to allow said subscriber to modify said predetermined radio frequency signal to initiate a predetermined network service;

multiple receiver means (11, 12, 14) adapted to be connected and distributed across said telephone network and able to receive said predetermined and modified radio frequency signals indicative of a specific network service requested by said subscriber;

signal modulation means (83) at said multiple receiver means for modulating said predetermined and modified



radio frequency signals into a modulated signal;  
 means (84) for sending, along a telephone line connected to said multiple receiver means, said modulated radio  
 frequency signal to a switch (16) connected to said network; and  
 means (17) for registering said subscriber service profile against said visited telephone set associated with said  
 5 second receiver device when said subscriber activates said input means, such that the subscriber's network serv-  
 ices and telephony features available from his home telephone set can be enabled at said visited telephone set.

According to a second aspect of the present invention there is provided a method of operating a system for providing  
 a personal communication and locator service, wherein transmitting devices (50, 51), which are carried by a subscriber  
 10 of the service, transmit at periodic intervals RF signals indicative of the identity of the subscriber and are provided with  
 means (62, 63) for modifying said RF signal, multiple receiver devices (11, 12, 14), which are connected and distributed  
 across a telephone network are adapted to receive the RF signals as the subscriber moves along the network from a  
 first receiver device associated with his home telephone set to a second receiver device associated with a visited  
 telephone set, the method comprising the steps of:

15 storing at database means (17) a list of subscriber profiles indicative of the identity of the subscriber and network  
 services available to that subscriber at his home telephone;  
 transmitting said RF signal, as a said subscriber moves towards said second receiver device associated with said  
 visited telephone set;  
 20 modulating said transmitted RF signal to obtain a modulated RF signal;  
 sending, along a telephone line connected to said second receiver device, said modulated RF signal to switching  
 means (16) connected to said network;  
 accessing said database means when said switching means receives said modulated signal;  
 searching said database means to find a profile associated with said modulated signal to identify the subscriber  
 25 and service profile; and  
 registering said subscriber service profile against said visited telephone set associated with said second receiver  
 device when said subscriber activates said modifying means, such that the subscriber's network services and  
 telephony features available from his home telephone set can be enabled at said visited telephone set.

30 **Brief Description of the Drawings**

Figure 1 is a block diagram illustrating a system for providing a locator and asset tracking service according to an  
 embodiment of the invention;  
 Figure 2a is an illustration of a possible mounting arrangement for an access control receiver according to a first  
 35 embodiment of the invention;  
 Figure 2b is an illustration of a possible mounting arrangement for an access control receiver according to a second  
 embodiment of the invention;  
 Figures 3a and 3b are illustrations of a possible mounting arrangement for a locator/asset tracking receiver ac-  
 cording to another embodiment of the invention;  
 40 Figures 4a, 4b and 4c are top, bottom and side views, respectively, of a typical asset tracking tag according to an  
 embodiment of the invention;  
 Figure 5 is a block diagram showing the general layout of the asset tracking tag of Figure 4;  
 Figures 6a and 6b are top and bottom views, respectively, of a typical locator ID badge according to an embodiment  
 of the invention;  
 45 Figure 7 is a block diagram showing the general layout of the locator ID badge of Figure 6;  
 Figure 8 is a block diagram of a locator/tracking receiver according to an embodiment of the invention; and  
 Figure 9 is an illustration of a typical transmission burst from a transmitting device.

50 **Detailed description of the Drawings**

Referring now to Figure 1, we have shown a diagram illustrating how the personal communication locator and  
 asset tracking service interacts with a telephone network. In particular, in one embodiment of the invention, the service  
 makes use of a transmitting device forming an integral part of an ID badge 10a and 10b and a receiving device located  
 either at a telephone terminal 11 or as part of an stand-alone unit 12 to provide a personal communication service. In  
 55 a second embodiment of the invention, the transmitting device can form part of an asset tracking tag attached or  
 secured to a material asset, such as a computer 13 or other piece of equipment. A receiving device 14 can also be  
 designed such that it can be connected between a telephone terminal 15 and a switch or PBX unit 16. Power to the  
 receiving device 14 is provided by the switch 16, via the telephone line. This provides a centralized battery backup,

reduces the cost of installation and also reduces the complexity of the system, since the units do not have to be placed near electrical outlets. As will be shown in Figures 2a, 2b, 3a and 3b, the receiving unit can be positioned in a number of areas of a building to provide the locator, asset tracking and access control services defined herein.

5 A database 17 associated with the telephone network records all data associated with the RF signal sent by the transmitting device via the RF signal receiving device attached to the telephone network. This recorded data will form the information database through which Personal Communications Services (PCS) can be realized. A workstation 18, such as a PC, can be used for accessing the database 17 for reading the information stored therein. Similarly, the PC can also be used to directly store the information received from the switch or PBX unit 16. Similarly, the workstation can continuously monitor movement of tags, in the case of asset tracking, wherein the PC would initiate a security sequence, such as alerting a security guard, if the asset is moved away from its assigned area.

### Access Control System

15 In one embodiment of the present invention, building entry and access control can be provided. In this application, the RF signal receivers can be located on the ceiling, or in the walls of a building, as shown in Figures 2a and 2b, to control the access to a room or building. For example, as shown in Figure 2a, receiver 20 is connected to a PBX (not shown) via an ISDN BRI link 21 or equivalent. In the embodiment shown, the receiver is also connected to a door latch 22 to allow or deny access of personnel to the computer room. Thus, only those employees that have an ID badge emitting the correct RF pattern will be allowed in the room.

20 In another application, a base station can be installed at a building entrance by mounting a receiving unit inside a passageway pedestal, as is shown in Figure 2b. The diagram shows the view of the pedestals 30a, 30b and 30c as would be seen by a user entering the building. At pedestal 30a, a receiver 31 mounted inside the pedestal is connected to an antenna 32. Receiver 31 is connected to front and back photoelectric sensors 33, loudspeaker 34 and alarm lamp 35. The base station receiver 31 monitor the photoelectric sensors 33 in order to distinguish incoming and outgoing traffic. In Figure 2b, only one sensor is shown for clarity. Front and back sensors would be positioned horizontally adjacent one another to identify movement of users. The base stations can be isolated by a dummy pedestal 30b, in order to allow use of multiple pedestals at the same entrance. Each dummy pedestal is provided with reflectors 36 positioned opposite sensors 33.

25 In this embodiment, the base station is a stand alone unit. The receiver 21 receives a radio message from the user's badge and grants access to the user by matching the ID code of the user's badge to the user's service address in an internal database located on site or on the network database. If the user is valid, a green lamp lights on, and the sensors are bypassed until the user walks by.

30 If the badge is invalid, or the user walks through without pressing the button on the badge, a red lamp will flash, and an alarm will sound via the loudspeaker 24. The loudspeaker is able to produce different alarm sounds to indicate different situations. The base station transmits a radio message which may be used at an alarm indicator box at the guard's desk.

35 In the case of visiting employees from other sites, as the visitor enters the building, the base station will access the corporate database. If the user is valid, the receiver will add the user to the visiting employee database, for use by sensors of other entrances as well.

40

### Asset Tracking System

45 When used for asset tracking, the system makes use of small tags which are attached on the interior or exterior of a material asset. Receiver units, distributed within the facilities, monitor the RF bursts from the ID tags. For example, at entrances and exits of the building or rooms therein, such as shown in Figures 2a and 2b, or in standard office partitions, such as shown in Figures 3a. In the illustration of Figure 3b, a receiver unit 37 is located at a corner junction 38 of the partition's walls 39. The receiver unit 37 is connected via a standard telephone line (not shown) to the switch or PBX unit. With this arrangement, the receiving unit can be used for both the asset tracking and personal locator services.

50 One embodiment of the asset tag is as shown in Figure 4a, 4b and 4c. The tag 40 is designed to be small in size to be unobtrusive. It is provided with an antenna 41 which is slightly raised above the top surface 42 of the tag for assets that have a metallic surface. The antenna is generally cross-shaped to permit an omnidirectional radiation pattern and provide spatial diversity which enhances the transmission reliability and range of the tag. In the embodiment shown, the bottom side of the tag 43 is provided with a sensor 44 surrounded by an adhesive surface 45. Sensor 44 is designed to detect the removal of the tag from the surface of an asset. For example, the sensor can be integrally formed with a permanent adhesive pad, such that any attempt to remove the tag, will destroy the adhesive pad and disconnect the sensor from the transmitter. It will of course be known to those knowledgeable in this art, that other sensor designs can be derived without departing from the scope of the invention. The surface 42 of the tag can be

55

provided with a bar type code 46 to assist in the programming and identification of tags prior to being placed on the asset.

If we now refer to Figure 5, we have shown a block diagram describing the layout of the transmitter in the asset tag. The transmitter is basically comprised of a microcontroller 50, a timer and power controller circuit 51 for power control and sensor registration detection. A sensor button 52 is connected to the controller 51 for detecting the removal of the asset tag. An RF oscillator 53 is used in conjunction with a modulator 54 and filter 55 for transmission of signal bursts to a receiver (not shown) via antenna 41. A battery 56 provides the necessary power to the transmitter circuit. The transmitter's microcontroller will monitor the sensor button status, check for low battery, send a burst signal for modulation by the modulator 54. The burst signal, as will be shown below, comprises a tag ID number, battery status, sensor button state and CRC.

### Personal Locator System

In Figure 6a and 6b, we have shown a top and bottom view of a user ID badge for use with the access control or personal locator systems. The top view shows that the badge can look like any other ordinary badge. However, as seen in Figure 6b, the badge can be comprised of two (2) programmable input buttons to allow a user to request specific personal communication and network services, as will be described below. The transmitter layout of the badge shown in Figure 7, is similar to that of the asset tag. The badge, however, can also make use of an etched antenna 60 which spirals around the perimeter of the badge to make it both compact and omnidirectional. The transmitter of the badge operates similarly to the one in the asset tag, except that the microcontroller 61 is provided with additional software to allow user access to the services described below. The ID badge shown in Figure 6a and 6b, can also be designed such that the control and registration buttons 62 and 63 are positioned on the same side as the photograph 64 of the badge.

### Receiver Unit

A block diagram of a receiver unit for use with the embodiments of Figures 2a, 2b, 3a and 3b is shown in Figure 8. The receiving unit is basically comprised of a transceiver 80 connected to an antenna 81 and a microcontroller 82. The microcontroller 82 communicates with a telephone interface 83 in order to communicate with the telephone network. The telephone interface 83, is used to modulate a received RF signal from an ID badge or asset tag, for transmission to the switch 16 and database 17. The link 84 is accomplished using an ISDN BRI link or equivalent. Power is provided to the power supply 85 from the telephone line. When the receiving unit is used as part of a pedestal entry system, an alarm speaker 86 is provided. A number of input/output devices 87, such as a door latch, lamp or LED, photocell, switches, etc. can be controlled by the micro controller 82. These input/output devices will vary according to the location and use of the receiving unit. A RAM 88 with battery backup 89 is provided for storing ID codes and firmware. The RAM battery backup 89 allows both user database and firmware to be preserved during a power failure.

### Radio Link

The radio link between a transmitting device of an ID badge or asset tag and the receiving devices is normally unidirectional. However, the tags and badges can be designed to react to certain prompts from the system, as in the case of an emergency or to request immediate identification of the ID badge user or asset tag. For example, the asset tag can be designed to send out its ID code upon crossing and sensing a low power electric or magnetic field near a doorway, thus enabling the asset tracking system to monitor the movement of the asset. Similarly, the ID badge could send out the user's ID code upon passing near a receiver unit at a telephone, office partition, doorway or building entrance, enabling the personal locator system to locate the user.

The system is designed such that at random intervals, the transmitter sends out an RF burst of information having a basic structure. For example, as shown in Figure 9, the radio burst can start with a 3 byte preamble 90, used for synchronization, followed by 10 bytes of data, including a header 91, an ID code 92, a Sequence Number 93 and CRC 94. The Length field 90 specifies the length of the packet (in bytes) excluding the length field itself. The length field can vary between 3 and 15 bits. The header byte allows for up to 256 message types. In the case of the ID badge, the ID code can be used to store a 7 digit (decimal) employee number (3 bytes) along with one byte company affiliation or location code. The telephone switch would map this number to a home telephone set used by the user. In the case of the asset tag, the ID code would be the asset's unique number.

In order to reduce the possibility of fraud on the system, the transmitter units in the asset tags and ID badges make use of a counter increase the sequence number by one each time the tag or ID badge sends out a new burst.

The following messages have been defined in the preferred embodiment of the invention. The TAG messages apply to the asset-tags only.

EP 0 578 374 B1

Hex	Message Type	Description
00	BADGE_LOCATION	Sent at regular intervals during Autonomous Mode
01	BADGE_S1	Sent when the top button on the badge is pressed
02	BADGE_S2	Sent when the bottom button on the badge is pressed
03	BADGE_DISTRESS	
04	BADGE_DEFECT	Sent at regular intervals when a badge has determined an internal malfunction
05	BADGE_LOW_BAT	Sent at regular intervals when the battery is low
06		
07	TAG_LOW_BAT	Sent at regular intervals when the battery is low
08	TAG_LOCATION	Sent at regular intervals when a tag is affixed to an asset
09	TAG_DISTRESS	Sent at regular intervals when a tag has been removed from an asset
0A	CONFIG_START	Programmer use only: Indicates beginning of configuration mode
0B	CONFIG_END	Programmer use only: Indicates end of configuration mode
0C	spare	
0D	spare	
0E	spare	
0F	DIAGNOSTICS	Programmer use only: Various functions

Before the burst is sent, the burst is scrambled. This is performed over the entire message including CRC, excluding the length field. It is used to reduce the possibility of sequential zeros which can degrade the reception quality at the base station.

The CRC bits are used to validate the burst and protect against collisions with competing transmitters.

During normal operation, the receiver will decode and validate incoming bursts from nearby ID badges and asset tags. This involves detecting the start of the burst, compensating for any DC offset in the incoming analog signals, performing Automatic Gain Control (AGC), by selecting the correct A-to-D input, clock recovery, removal of balance bits and CRC bits validation. The receiver will also keep a list of all ID badges and assets within range, including the filtering of spurious signals from other ID badges and asset tags. This can occur when, for example, ID codes from multiple badges and/or asset tags collide or are corrupted. The receiver will then send the ID's, with encrypted burst counters, and signal strengths to the telephone switch and report registration of ID badges, tag tampering and which ID badges and asset exit a receiver's operating area.

**Personal Locator Service**

The personal communication locator system can provide a number of PCS telephony features and services when a user makes use of the control buttons 62 and 63 (Figure 6b) on the ID badge. In the preferred embodiment, three operational states can exist:

- Located: The telephone network knows the location of the user. This can be achieved by an autonomous periodic RF signal transmitted from the ID badge's transmitter.
- Registered: The telephone network is granted permission by the user to act upon the knowledge of the user's location. The registration can be established through the use of a button depression on the ID badge. By pressing this button, a modified RF signal is transmitted, thus enabling the user to register in the network.
- Logon: Transfers the user's service configuration to a specific telephone set that the user wish to "log" on. The actual logon procedure can be realized through the use of one or both buttons, depressed simultaneously or in sequence.

The Located state is activated as soon as the user's ID badge sends out a signal and the signal is picked up by a network receiver. This state can be used in emergency situations to get a call to the user.

Inbound PCS can be accomplished through the use of Registered state, in this state all calls to the user are automatically redirected to the phone on which the user has registered. Registration can occur by pushing a button on the locator tag, using display with softkeys technology on telephone sets, using voice response units, or using voice

recognition techniques. For example, as shown in Figure 1, if user A of badge 10a has telephone 11 for a home set, i.e. the user's usual telephone set, then being Located at that set will cause automatic registration. For example, when the user walks back to his office after visiting a colleague on another floor.

5 When a call arrives for a user, the network verifies whether the user has subscribed to the PCS service. A database query will be performed, and the user's new location information will be returned to the switch for proper routing. Call Screening can be accomplished as the user's screening data will be embedded in the database, as screening is applied, new routing info will be returned to the switch. The switch can then reroute the call to the appropriate destination as specified by the user.

10 The Logon state allows for outbound PCS functionality where the user's profile is placed against the telephone set the user has logged onto. This allows the user to obtain their services at the logged on set, have their name and number send out with each call, and have calls placed from that set billed to the logged on user. For example, as in the above example, if user A happens to be using the office where telephone set 15 is located, user A can "logon" or "register" his profile to that telephone set by pressing one or two of the buttons on his or her badge. Upon pressing the buttons, the RF burst associated with that command will be received by the telephone set 15, modulated for transmission on the connecting line to the PBX 16. Once received, database 17 will then associate the profile of user A to telephone set 15. Thus, when the user makes use of that telephone set, all features associated in the network with that user will be provided to the user.

15 By using the location and state information of both the calling user and called users, a number of new services can be developed. For example, when a user does not answer an incoming call, the network will normally route the call to a voice mail after 3 to 4 rings at the user's set. With the locator system of the present invention, if the network does not know the location of the user then there is no need to provide ringing to the calling user before the call forward no answer (CFNA) service is invoked. Instead the call will be forwarded to a voice mail immediately because the network knows that the called user can not be reached. The voice mail storage facility can either be an integral part of switch 16, or an external service (not shown). Some other services that can be implemented are as follows:

25 - Call When Both Home (CWBH):

A call completion feature which allows the calling user to specify that the network set up a call between the calling user and the called user when both users are located at their home location.

30 As an example, if user A needs to communicate with user B wearing badge 10b, then, other than leaving a voice mail when user B is not available, user A activates the CWBH feature from his home telephone, i.e. telephone 11. When user B returns to his office, he will become automatically registered on the network, since telephone set 15 is his "home location", and a call will be initiated between user A and B.

35 - Call When Both Registered (CWBR):

This service is similar to call when both home, the only difference is the call is set up when both users are registered in the network as opposed to being at their home location.

40 This, for example, could happen when user A is making use of a temporary office and user B happens to be in the building's main conference room. If user A is initiating the call, the service feature could be enabled by making use of soft keys on the telephone set, pressing a predetermined sequence of buttons on the badge, or other activation feature.

- Caller Negotiation:

45 This feature puts the choice of call termination treatment back into the hands of the calling user. In today's network if the call is call forward no answer (CFNA) to a voice mail machine, the calling user can only leave a message or be rerouted to a live attendant. Caller Negotiation allows the call to be suspended and presents the calling user a choice of what service they would like. If a call forward no answer is about to occur, the user may be presented with the following choices: Voice Mail, Secretary, CWBH, CWBR, and Page.

50 - Call Disruption:

This feature is based on the called user location's proximity information. For example, a single receiver located at a telephone set of a conference room, may receive multiple location signals for different locators in the immediate area.

55 This can be interpreted as a meeting in progress amongst the users carrying the ID badges. The caller calling a specific user in this situation can therefore be informed that "a meeting is in progress", and thus be able to negotiate the call destination. For example, in Figure 1, if user A is in the office of user B, then the receiver at telephone set 15 will receive multiple location signals. The system can be designed such that the system's response provide the calling party with

## EP 0 578 374 B1

either the number of people in user B's office, who is present, or whether a visitor, wearing a visitor badge is present. The visitor badge could, of course, be programmed to provide the name of the visiting individual and his company name. This interrupt feature could, for example, be provided only if the calling party is at a higher reporting level than the called party, such as the employee's supervisor.

5 - Autonomous ring tone volume control:

10 With this feature, the receiver has the ability to detect the signal strength of the RF signal transmitted by the ID badge. A strong signal indicates that the user is in the immediate proximity of the receiver, a weak signal implies that the user is at a distance from the receiver. If this receiver is integrated into a telephone set, it can relay the RF signal strength to the set, thus allowing the telephone to adjust its ringing volume as calls arrive on the set.

- Handsfree call by name:

15 With this feature, one of the buttons on the badge can be programmed to request call origination. For example, if a receiver embedded into a telephone set that has handsfree operations receives an RF signal associated with this button depression and forwards this information to the network, the network can instruct the telephone set to start handsfree operation. At the same time, the network can validate the user associated with the transmitter to grant such service request. Once validated, the network will connect this telephone to a voice recognition server, which can be located either with the database 17 or the PBX 16. The user will announce the name of the intended called party. This voice message will be transmitted through the handsfree unit of the telephone to the voice recognition server. The server will then match the name of the called party provided by the user to one in the name file of the system. Once a match is found, the server will relay the call routing digits to the telephone network, thereby completing the call.

25 - Feature button programming:

30 This feature allows users to program the buttons on their badges to operate a specific telephone network feature required. Thus, when the user presses the selected button, the network feature will be activated. The programming can be done from any telephone set using interactive displays/voice response systems using soft keys. Once the feature is selected, the user is prompted to select a specific button on the ID badge. As the button is depressed, the associated RF signal will be received by the telephone network and it will be designated as required RF signal for requesting the selected feature.

35 The programming of the buttons could also be done when the user request a badge from, say, the company's security group. Thus, the user would simply indicate the type of features to be activated, which button sequence to be used and provide his or her associated profile upon requesting a new badge. Accordingly, in use, the network would associate the user's use of the buttons with a service listed in the user's profile. Thus, the depression of a button on the badge of user A and B both provide the same RF burst. However, the combination of that RF burst with user A's ID code results in a different feature than the RF burst with user B's ID code.

### 40 Claims

45 1. A system for providing a personal communication and locator service within a telephone network as a subscriber moves along the network from a first receiver device associated with his home telephone set to a second receiver device associated with a visited telephone set, the system comprising:

database storage means (17), for storing a list of subscriber profiles indicative of the identity of the subscriber and network services available to that subscriber at his home telephone set;

50 transmitter means (50, 51) adapted to be carried by a subscriber, and able to transmit a predetermined radio frequency signal;

input means (62, 63) at said transmitter means to allow said subscriber to modify said predetermined radio frequency signal to initiate a predetermined network service;

55 multiple receiver means (11, 12, 14) adapted to be connected and distributed across said telephone network and able to receive said predetermined and modified radio frequency signals indicative of a specific network service requested by said subscriber;

signal modulation means (83) at said multiple receiver means for modulating said predetermined and modified radio frequency signals into a modulated signal;

means (84) for sending, along a telephone line connected to said multiple receiver means, said modulated

- radio frequency signal to a switch (16) connected to said network; and means (17) for registering said subscriber service profile against said visited telephone set associated with said second receiver device when said subscriber activates said input means, such that the subscriber's network services and telephony features available from his home telephone set can be enabled at said visited telephone set.
- 5
2. A system as claimed in claim 1, characterised in that said transmitter means is embedded in an ID badge (10a, 10b) carried by said subscriber and said input means comprises programmable button means to allow said user to modify said predetermined radio frequency signal.
  - 10 3. A system as claimed in claim 1 or 2, characterised in that the transmitter means is further comprised of:
    - microcontroller means (61) connected to said programmable button means;
    - radio frequency oscillator and modulator means connected to said microcontroller means;
    - 15 antenna means (60) for transmitting a radio frequency signal generated by said radio frequency oscillator and modulator means; and
    - means for providing power to said microcontroller, radio frequency oscillator and modulator means.
  4. A system as claimed in claim 3, characterised in that said antenna means provides an omnidirectional radiation pattern and spatial diversity.
  - 20 5. A system as claimed in claim 4, characterised in that said antenna means is generally cross-shaped.
  6. A system as claimed in claim 4, characterised in that said antenna means comprises a spirally etched metallic film extending around the perimeter of the badge.
  - 25 7. A system as claimed in any one of claims 1 to 6, characterised in that said receiver means comprises:
    - radio transceiver means (80);
    - 30 antenna means (81) connected to said radio transceiver means for capturing said radio frequency signal from said transmitter means;
    - microcontroller means (82) connected to said radio transceiver means and telephone interface means, said telephone interface means allowing said radio transceiver means to access said telephone network;
    - 35 power supply means connected to said telephone interface means for obtaining power from a telephone line connected to said receiver means; and
    - input/output means (87) for connecting to accessories required for providing said locator and access control service.
  - 40 8. A system as claimed in claim 7, characterised in that said receiver means forms an integral part of a telephone set connected to said network.
  9. A system as claimed in claim 7, characterised in that said receiver means is part of a stand-alone unit connected to said telephone network via a telephone line.
  - 45 10. A system as claimed in claim 9, characterised in that said receiver means is positioned adjacent an access control point to monitor, allow or deny access to predetermined ID badge users.
  11. A system as claimed in claim 10, characterised in that said receiver means is positioned at a doorway for controlling access through said doorway.
  - 50 12. A system as claimed in claim 11, characterised in that said input/output means is connected to a door latch of said doorway.
  13. A system as claimed in claim 10, characterised in that said receiver means is positioned at a building entrance pedestal for controlling access through said building.
  - 55 14. A system as claimed in claim 13, characterised in that said input/output means is connected to photoelectric sensors and an alarm system of said pedestal.

15. A system as claimed in claim 10, characterised in that said receiver means is positioned at office partitions.
16. A system as claimed in any one of claims 1 to 15, characterised in that said RF signal comprises an RF burst of data sent at random intervals.
- 5 17. A system as claimed in claim 16, characterised in that said RF burst comprises a series of preamble bits followed by a header, badge code ID code, sequence number and CRC bits.
- 10 18. A method of operating a system for providing a personal communication and locator service, wherein transmitting devices (50, 51), which are carried by a subscriber of the service, transmit at periodic intervals RF signals indicative of the identity of the subscriber and are provided with means (62, 63) for modifying said RF signal, multiple receiver devices (11, 12, 14), which are connected and distributed across a telephone network are adapted to receive the RF signals as the subscriber moves along the network from a first receiver device associated with his home telephone set to a second receiver device associated with a visited telephone set, the method comprising the steps of:
- 15 storing at database means (17) a list of subscriber profiles indicative of the identity of the subscriber and network services available to that subscriber at his home telephone;  
transmitting said RF signal, as a said subscriber moves towards said second receiver device associated with said visited telephone set;  
20 modulating said transmitted RF signal to obtain a modulated RF signal;  
sending, along a telephone line connected to said second receiver device, said modulated RF signal to switching means (16) connected to said network;  
accessing said database means when said switching means receives said modulated signal;  
25 searching said database means to find a profile associated with said modulated signal to identify the subscriber and service profile; and  
registering said subscriber service profile against said visited telephone set associated with said second receiver device when said subscriber activates said modifying means, such that the subscriber's network services and telephony features available from his home telephone set can be enabled at said visited telephone set.
- 30 19. A method as claimed in claim 18, characterised in that a call directed to the home telephone set of said subscriber is forwarded automatically to said visited telephone set when said subscriber has registered his service profile thereto.
- 35 20. A method as claimed in claim 19, characterised in that a call between a first subscriber and a second subscriber can be completed when both subscribers have registered to nearby receiving devices.
- 40 21. A method as claimed in claim 19, characterised in that an incoming call directed to a subscriber located at a receiving device which is receiving multiple RF signals is forwarded to a voice mail device.

#### Patentansprüche

- 45 1. System zur Bereitstellung eines Personalkommunikations- und Standortbestimmungs-Dienstes in einem Telefonnetz, wenn sich ein Teilnehmer entlang des Netzes von einer ersten Empfängereinrichtung, die seinem Heimat-Telefonapparat zugeordnet ist, zu einer zweiten Empfängereinrichtung bewegt, die einem besuchten Telefonapparat zugeordnet ist, wobei das System folgendes umfaßt:
- 50 Datenbank-Speichereinrichtungen (17) zum Speichern einer Liste von Teilnehmerprofilen, die die Identität des Teilnehmers und die Netzwerkdienste anzeigen, die diesem Teilnehmer an seinem Heimat-Telefonapparat zur Verfügung stehen,
- Sendereinrichtungen (50,51), die von einem Teilnehmer getragen werden können und in der Lage sind, ein vorgegebenes Hochfrequenzsignal auszusenden,
- 55 Eingabeeinrichtungen (62,63) an den Sendereinrichtungen, die es dem Teilnehmer ermöglichen, das vorgegebene Hochfrequenzsignal zu modifizieren, um einen vorgegebenen Netz-Dienst einzuleiten,
- mehrfache Empfängereinrichtungen (11,12,14), die zur Verbindung und zur Verteilung läng des Telefonnetzes



## EP 0 578 374 B1

ausgebildet sind und die vorgegebenen und modifizierten Hochfrequenzsignale empfangen können, die einen speziellen Netz-Dienst anzeigen, der von dem Teilnehmer angefordert wird,

5 Signalmodulationseinrichtungen (83) an den mehrfachen Empfängereinrichtungen zur Modulation der vorgegebenen und modifizierten Hochfrequenzsignale in ein moduliertes Signal,

Einrichtungen (84) zum Aussenden des modulierten Hochfrequenzsignals über eine mit den mehrfachen Empfängereinrichtungen verbundene Telefonleitung an eine Vermittlung (16), die mit dem Netz verbunden ist, und

10 Einrichtungen (17) zur Registrierung des Teilnehmer-Dienstprofils an dem besuchten Telefonapparat, der der zweiten Empfängereinrichtung zugeordnet ist, wenn der Teilnehmer die Eingabeeinrichtung aktiviert, derart, daß die Netzwerkdienste und Telefonmerkmale des Teilnehmers, die diesem an seinem Heimat-Telefonapparat zur Verfügung stehen, an dem besuchten Telefonapparat freigegeben werden können.

15 **2.** System nach Anspruch 1, dadurch gekennzeichnet, daß die Sendereinrichtung in eine Identifikations-Ausweiskarte (10a,10b) eingebettet ist, die von dem Teilnehmer getragen wird, und daß die Eingabeeinrichtung programmierbare Druckknopf-  
einrichtungen umfaßt, um es dem Benutzer zu ermöglichen, das vorgegebene Hochfrequenzsignal zu modifizieren.

20 **3.** System nach Anspruch 1 oder 2, dadurch gekennzeichnet, daß die Sendereinrichtung weiterhin folgende Teile umfaßt:

Mikrocontrollereinrichtungen (61), die mit den programmierbaren Druckknopf-  
einrichtungen verbunden sind,

25 Hochfrequenzoszillator- und Modulatoreinrichtungen, die mit der Mikrocontrollereinrichtung verbunden sind,

Antenneneinrichtungen (60) zur Aussendung eines Hochfrequenzsignals, das von den Hochfrequenzoszillator- und Modulatoreinrichtungen erzeugt wird, und

30 Einrichtungen zur Lieferung von Leistung an den Mikrocontroller und die Hochfrequenzoszillator- und Modulatoreinrichtungen.

4. System nach Anspruch 3, dadurch gekennzeichnet, daß die Antenneneinrichtung ein Rundstrahl-  
diagramm und Raumdiversity ergibt.

35 **5.** System nach Anspruch 4, dadurch gekennzeichnet, daß die Antenneneinrichtung allgemein kreuzförmig ist.

40 **6.** System nach Anspruch 4, dadurch gekennzeichnet, daß die Antenneneinrichtung einen spiralförmig geätzten Metallfilm umfaßt, der sich um den Umfang der Ausweiskarte herum erstreckt.

45 **7.** System nach einem der Anspruch 1 - 6, dadurch gekennzeichnet, daß die Empfängereinrichtung folgende Teile umfaßt:

Hochfrequenz-Sendeempfängereinrichtungen (80),

eine Antenneneinrichtung (81), die mit der Hochfrequenz-Sendeempfängereinrichtung verbunden ist, um das Hochfrequenzsignal von der Sendeeinrichtung aufzufangen,

50 eine mit der Hochfrequenz-Sendeempfängereinrichtung und einer Telefon-Schnittstelleneinrichtung verbundene Mikrocontrollereinrichtung (82), wobei die Telefon-Schnittstelleneinrichtung einen Zugriff der Hochfrequenz-Sendeempfängereinrichtung auf das Telefonnetz ermöglicht,

55 eine Leistungsversorgungseinrichtung, die mit der Telefon-Schnittstelleneinrichtung verbunden ist, um Leistung von einer Telefonleitung zu gewinnen, die mit der Empfängereinrichtung verbunden ist, und

eine Eingabe-/Ausgabeeinrichtung (87) zum Verbinden mit Zubehöreinrichtungen, die zur Schaffung des

## EP 0 578 374 B1

Standortbestimmungs- und Zugangskontrolldienstes erforderlich sind.

- 5
8. System nach Anspruch 7,  
dadurch gekennzeichnet, daß die Empfängereinrichtung einen einstückigen Teil eines Telefonapparates bildet,  
der mit dem Netz verbunden ist.
- 10
9. System nach Anspruch 7,  
dadurch gekennzeichnet, daß die Empfängereinrichtung einen Teil einer unabhängigen Einheit bildet, die mit dem  
Telefonnetz über eine Telefonleitung verbunden ist.
- 15
10. System nach Anspruch 9,  
dadurch gekennzeichnet, daß die Empfängereinrichtung in der Nähe eines Zugangskontrollpunktes angeordnet  
ist, um den Zugang für vorgegebene Identifikations-Ausweiskarten-Benutzer zu überwachen, zu ermöglichen oder  
zu verweigern.
- 20
11. System nach Anspruch 10,  
dadurch gekennzeichnet, daß die Empfängereinrichtung in einem Durchgang zur Steuerung des Zuganges durch  
den Durchgang angeordnet ist.
- 25
12. System nach Anspruch 11,  
dadurch gekennzeichnet, daß die Eingabe-/Ausgabeeinrichtung mit einem Türriegel des Durchganges verbunden  
ist.
- 30
13. System nach Anspruch 10,  
dadurch gekennzeichnet, daß die Empfängereinrichtung in einem Sockel an einem Gebäudeeingang zur Steue-  
rung des Zuganges durch das Gebäude angeordnet ist.
- 35
14. System nach Anspruch 13,  
dadurch gekennzeichnet, daß die Eingabe-/Ausgabeeinrichtung mit photoelektrischen Sensoren und einem Alarm-  
system des Sockels verbunden ist.
- 40
15. System nach Anspruch 10,  
dadurch gekennzeichnet, daß die Empfängereinrichtung an Büro-Trennwänden angeordnet ist.
- 45
16. System nach einem der Ansprüche 1 - 15,  
dadurch gekennzeichnet, daß das Hochfrequenzsignal einen Hochfrequenz-Datenblock umfaßt, der zu zufälligen  
Intervallen ausgesandt wird.
- 50
17. System nach Anspruch 16,  
dadurch gekennzeichnet, daß der Hochfrequenz-Datenblock eine Serie von Vorspannbits, gefolgt von einem An-  
fangsblock, einem Ausweiscode-Identifikationscode, einer Sequenznummer und CRC-Bits umfaßt.
- 55
18. Verfahren zum Betrieb eines Systems zur Bereitstellung eines Personalkommunikations- und Standortbestim-  
mungsdienstes, bei dem Sendereinrichtungen (50,51), die von einem Teilnehmer des Dienstes getragen werden,  
zu periodischen Zeitintervallen die Identität des Teilnehmers anzeigende Hochfrequenzsignale aussenden und  
mit Einrichtungen (62,63) zur Modifikation des Hoch frequenzsignals versehen sind, mehrfache Empfängerein-  
richtungen (11,12,14), die mit einem Telefonnetz verbunden und längs dieses Netzes verteilt sind, zum Empfang  
der Hochfrequenzsignale ausgebildet sind, während sich der Teilnehmer entlang des Netzes von einer ersten  
Empfängereinrichtung, die seinem Heimat-Telefonapparat zugeordnet ist, zu einer zweiten Empfängereinrichtung  
bewegt, die einem besuchten Telefonapparat zugeordnet ist, wobei das Verfahren die folgenden Schritte umfaßt:
- Speichern an einer Datenbankeinrichtung (17) einer Liste von Teilnehmerprofilen, die die Identität des Teil-  
nehmers und die diesem Teilnehmer an seinem Heimat-Telefon zur Verfügung stehenden Netzdienste anzei-  
gen,
- Aussenden des Hochfrequenzsignals, während sich der Teilnehmer zu der zweiten Empfängereinrichtung  
bewegt, die dem besuchten Telefonapparat zugeordnet ist,

## EP 0 578 374 B1

Modulieren des ausgesandten Hochfrequenzsignals zur Gewinnung eines modulierten Hochfrequenzsignals,

Aussenden des modulierten Hochfrequenzsignals an mit dem Netz verbundene Vermittlungseinrichtungen (16) über eine mit der zweiten Empfängereinrichtung verbundene Telefonleitung,

Zugreifen auf die Datenbankeinrichtung, wenn die Vermittlungseinrichtung das modulierte Signal empfängt,

Durchsuchen der Datenbankeinrichtung zum Auffinden eines Profils, das dem modulierten Signal zugeordnet ist, um den Teilnehmer und das Dienstprofil zu identifizieren, und

Registrieren des Teilnehmer-Dienstprofils bei dem besuchten Telefonapparat, der der zweiten Empfängereinrichtung zugeordnet ist, wenn der Teilnehmer die Modifikationseinrichtung aktiviert, derart, daß die Netzwerkdienste und Telefonmerkmale des Teilnehmers, die diesem an seinem Heimat-Telefonapparat zur Verfügung stehen, an dem besuchten Telefonapparat freigegeben werden können.

**19.** Verfahren nach Anspruch 18, dadurch gekennzeichnet, daß ein an den Heimat-Telefonapparat des Teilnehmers gerichteter Anruf automatisch zu dem besuchten Telefonapparat weitergeleitet wird, wenn der Teilnehmer sein Dienstprofil an diesem registriert hat.

**20.** Verfahren nach Anspruch 19, dadurch gekennzeichnet, daß ein Anruf zwischen einem ersten Teilnehmer und einem zweiten Teilnehmer aufgebaut werden kann, wenn beide Teilnehmer sich bei nahegelegenen Empfangseinrichtungen registriert haben.

**21.** Verfahren nach Anspruch 19, dadurch gekennzeichnet, daß ein ankommender Anruf, der an einen Teilnehmer gerichtet ist, der sich an einer Empfangseinrichtung befindet, die mehrere Hochfrequenzsignale empfängt, zu einer Sprachmitteilungseinrichtung weitergeleitet wird.

### Revendications

**1.** Système destiné à donner des services de communications personnelles et de localisation dans un réseau téléphonique lorsqu'un abonné se déplace le long du réseau, d'un premier dispositif récepteur associé à son poste téléphonique de domicile à un second dispositif récepteur associé à un poste téléphonique visité, le système comprenant :

un dispositif (17) de mémorisation de base de données destiné à mémoriser une liste de profils d'abonné représentative de l'identité de l'abonné et des services du réseau disponibles pour cet abonné à son poste téléphonique de domicile,

un dispositif émetteur (50, 51) destiné à être porté par l'abonné et qui peut transmettre un signal prédéterminé à hautes fréquences,

un dispositif de saisie (62, 63) du dispositif émetteur destiné à permettre à l'abonné de modifier le signal prédéterminé à hautes fréquences pour déclencher un service prédéterminé du réseau,

plusieurs dispositifs récepteurs (11, 12, 14) destinés à être connectés au réseau téléphonique, distribués dans celui-ci et capables de recevoir les signaux prédéterminés et modifiés à hautes fréquences représentatifs d'un service particulier du réseau demandé par l'abonné,

un dispositif (83) de modulation de signaux placé aux divers dispositifs récepteurs pour la modulation des signaux prédéterminés et modifiés à hautes fréquences sur un signal modulé,

un dispositif (84) d'émission, le long d'une ligne téléphonique connectée aux divers dispositifs récepteurs, du signal modulé à hautes fréquences à un commutateur (16) connecté au réseau, et

un dispositif (17) d'enregistrement du profil de service d'abonné pour le poste téléphonique visité associé au second dispositif récepteur lorsque l'abonné active le dispositif de saisie, si bien que les caractéristiques de téléphonie et de service du réseau de l'abonné disponibles à son poste téléphonique de domicile peuvent être autorisées au poste téléphonique visité.

**2.** Système selon la revendication 1, caractérisé en ce que le dispositif émetteur est enrobé dans un badge d'identification (10a, 10b) porté par l'abonné et le dispositif de saisie comprend un dispositif à bouton programmable

## EP 0 578 374 B1

destiné à permettre à l'utilisateur de modifier le signal prédéterminé à hautes fréquences.

3. Système selon la revendication 1 ou 2, caractérisé en ce que le dispositif émetteur comprend en outre :
  - 5 un dispositif (61) à organe de commande à microcontrôleur connecté au dispositif à bouton programmable, un dispositif oscillateur à hautes fréquences et modulateur connecté au dispositif à organe de commande, un dispositif à antenne (60) destiné à transmettre un signal à hautes fréquences créé par le dispositif oscillateur à hautes fréquences et modulateur, et
  - 10 un dispositif destiné à transmettre de l'énergie à l'organe de commande et au dispositif oscillateur à hautes fréquences et modulateur.
4. Système selon la revendication 3, caractérisé en ce que le dispositif à antenne donne un diagramme omnidirectionnel de rayonnement et une diversité spatiale.
- 15 5. Système selon la revendication 4, caractérisé en ce que le dispositif à antenne a une forme générale en croix.
6. Système selon la revendication 4, caractérisé en ce que le dispositif à antenne comporte un film métallique gravé en spirale placé autour de la périphérie du badge.
- 20 7. Système selon l'une quelconque des revendications 1 à 6, caractérisé en ce que le dispositif récepteur comporte :
  - un dispositif émetteur-récepteur radioélectrique (80),
  - un dispositif à antenne (81) connecté au dispositif émetteur-récepteur radioélectrique pour la saisie du signal à hautes fréquences provenant du dispositif émetteur,
  - 25 un dispositif (82) à organe de commande à microcontrôleur connecté au dispositif émetteur-récepteur radioélectrique et au dispositif d'interface téléphonique, le dispositif d'interface téléphonique permettant au dispositif émetteur-récepteur à hautes fréquences d'avoir accès au réseau téléphonique,
  - un dispositif d'alimentation connecté au dispositif d'interface téléphonique pour l'obtention d'énergie à partir d'une ligne téléphonique connectée au dispositif récepteur, et
  - 30 un dispositif d'entrée-sortie (87) destiné à assurer la connexion à des accessoires nécessaires pour le service de localisation et de contrôle d'accès.
8. Système selon la revendication 7, caractérisé en ce que le dispositif récepteur est partie intégrante d'un poste téléphonique connecté au réseau.
- 35 9. Système selon la revendication 7, caractérisé en ce que le dispositif récepteur fait partie d'une unité autonome connectée au réseau téléphonique par une ligne téléphonique.
10. Système selon la revendication 9, caractérisé en ce que le dispositif récepteur est positionné près d'un point de contrôle d'accès pour le contrôle de l'accès d'utilisateurs prédéterminés à base d'identification, en permettant ou en interdisant cet accès.
- 40 11. Système selon la revendication 10, caractérisé en ce que le dispositif récepteur est placé à une entrée de porte pour le contrôle d'accès par la porte.
- 45 12. Système selon la revendication 11, caractérisé en ce que le dispositif d'entrée-sortie est connecté à une serrure de porte de l'entrée.
13. Système selon la revendication 10, caractérisé en ce que le dispositif récepteur est placé dans un socle à l'entrée d'un bâtiment pour le contrôle de l'accès dans le bâtiment.
- 50 14. Système selon la revendication 13, caractérisé en ce que le dispositif d'entrée-sortie est connecté à des capteurs photoélectriques et un système d'alarme du socle.
- 55 15. Système selon la revendication 10, caractérisé en ce que le dispositif récepteur est placé dans des cloisons de bureau.
16. Système selon l'une quelconque des revendications 1 à 15, caractérisé en ce que le signal à hautes fréquences

## EP 0 578 374 B1

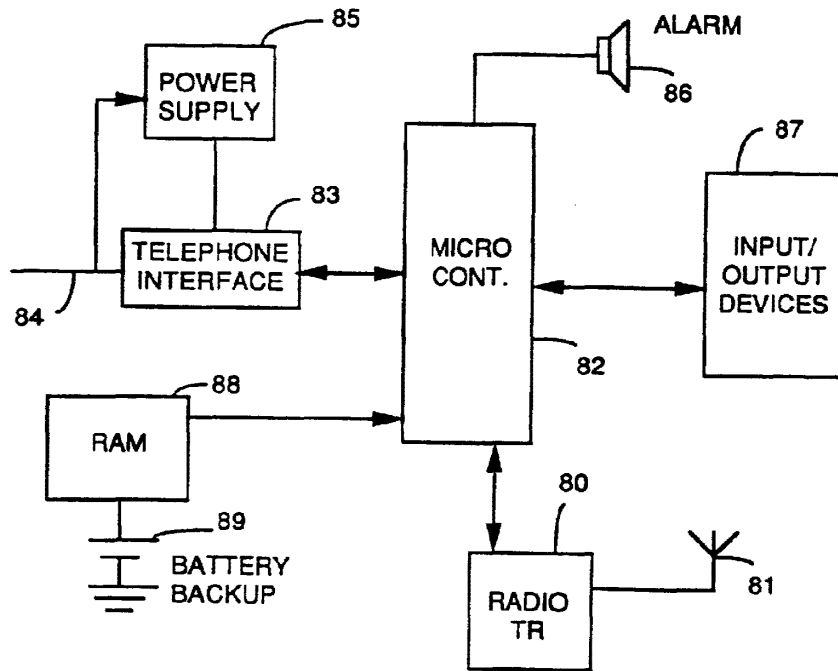
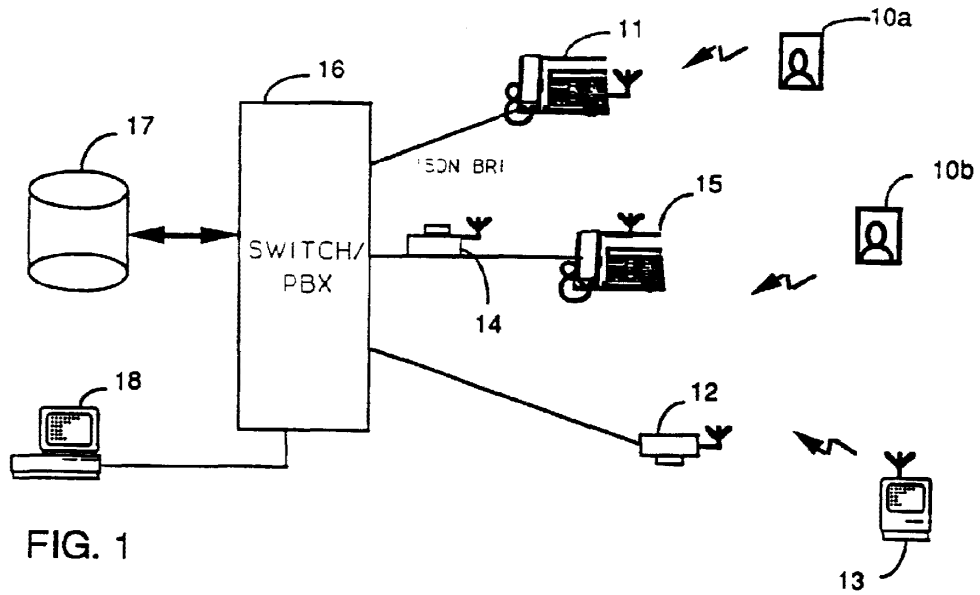
comprend une salve de données à hautes fréquences émise à des intervalles aléatoires.

- 5
17. Système selon la revendication 16, caractérisé en ce que la salve à hautes fréquences comprend une série de bits de préambule suivie d'un en-tête, d'un code d'identification de badge, d'un numéro de séquence et de bits de code CRC.
- 10
18. Procédé d'exploitation d'un système destiné à assurer un service de communications personnelles et de localisation, dans lequel les dispositifs de transmission (50, 51) qui sont transportés par un abonné du service transmettent à intervalles périodiques des signaux à hautes fréquences représentatifs de l'identité de l'abonné et comportent un dispositif (62, 63) destiné à modifier le signal à hautes fréquences, et plusieurs dispositifs récepteurs (11, 12, 14) qui sont connectés à un réseau téléphonique et distribués sur celui-ci, sont destinés à recevoir les signaux à hautes fréquences lorsque l'abonné se déplace le long du réseau d'un premier dispositif récepteur associé à son poste téléphonique de domicile à un second dispositif récepteur associé à un poste téléphonique visité, le procédé comprenant les étapes suivantes :
- 15
- la mémorisation, dans un dispositif à base de données (17) d'une liste de profils d'abonné représentative de l'identité de l'abonné et des services du réseau disponibles pour cet abonné à son téléphone de domicile, la transmission du signal à hautes fréquences lorsque l'abonné se déplace vers le second dispositif récepteur associé au poste téléphonique visité,
- 20
- la modulation du signal transmis à hautes fréquences pour l'obtention d'un signal modulé à hautes fréquences, l'émission, par une ligne téléphonique connectée au second dispositif récepteur, du signal modulé à hautes fréquences à un dispositif de commutation (16) connecté au réseau,
- 25
- l'accès au dispositif à base de données lorsque le dispositif de commutation reçoit le signal modulé, la recherche dans le dispositif à base de données pour la détermination d'un profil associé au signal modulé en vue de l'identification de l'abonné et du profil de service, et l'enregistrement du profil de service de l'abonné pour le poste téléphonique visité, associé au second dispositif récepteur, lorsque l'abonné active le dispositif de modification, si bien que les caractéristiques de téléphonie et de service de réseau de l'abonné disponibles à son poste téléphonique de domicile peuvent être autorisées par le poste téléphonique visité.
- 30
19. Procédé selon la revendication 18, caractérisé en ce qu'un appel dirigé vers le poste téléphonique du domicile de l'abonné est transmis automatiquement au poste téléphonique visité lorsque l'abonné a enregistré son profil de service à ce poste.
- 35
20. Procédé selon la revendication 19, caractérisé en ce qu'un appel réalisé entre un premier abonné et un second abonné peut être exécuté lorsque les deux abonnés se sont enregistrés à des dispositifs récepteurs voisins.
- 40
21. Procédé selon la revendication 19, caractérisé en ce qu'un appel entrant dirigé vers un abonné placé à un dispositif récepteur qui reçoit plusieurs signaux à hautes fréquences est transmis à un dispositif de messagerie vocale.

45

50

55



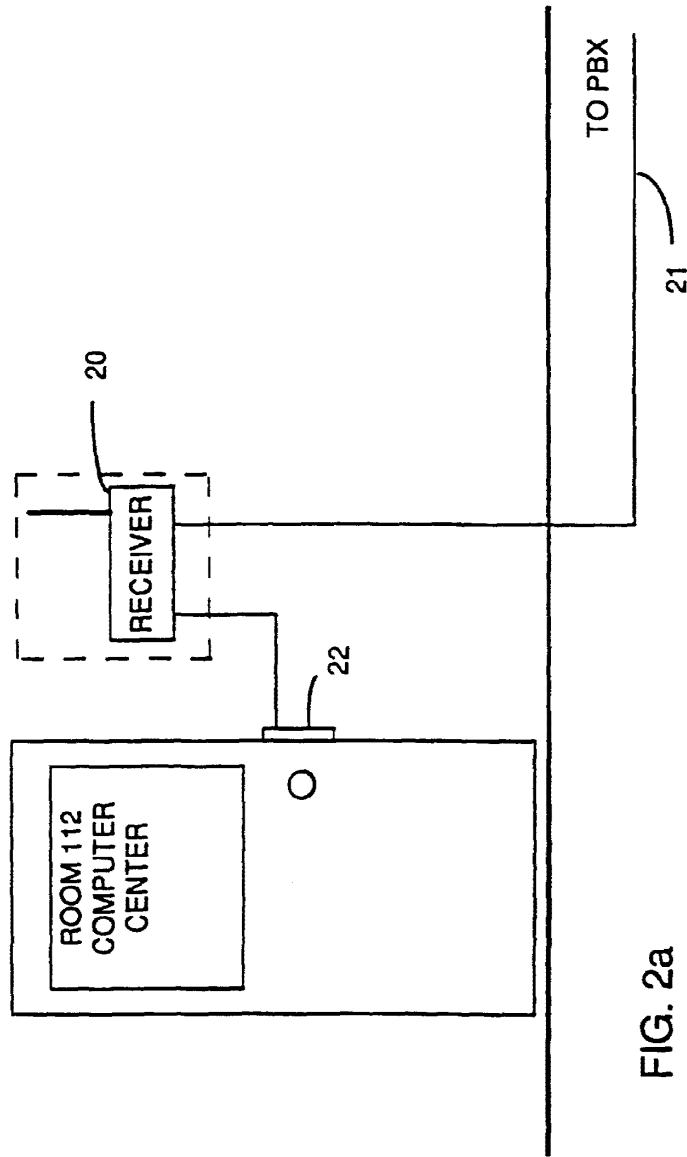


FIG. 2a

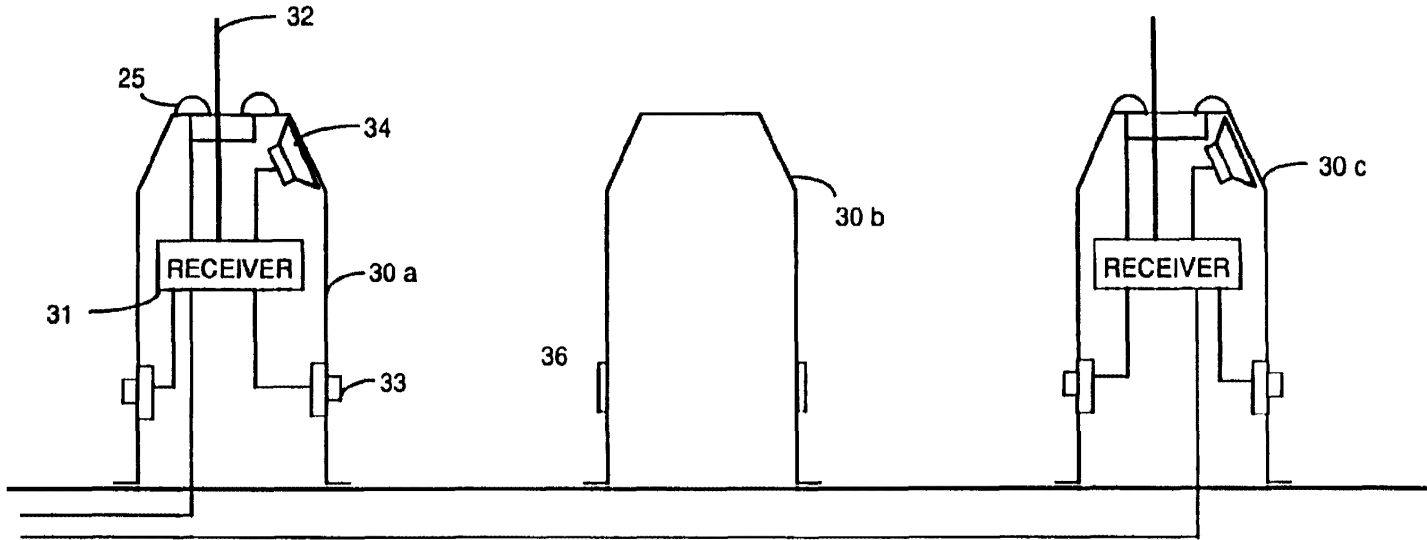


FIG. 2b

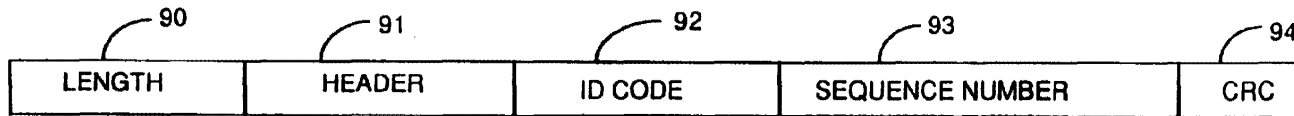


FIG. 9



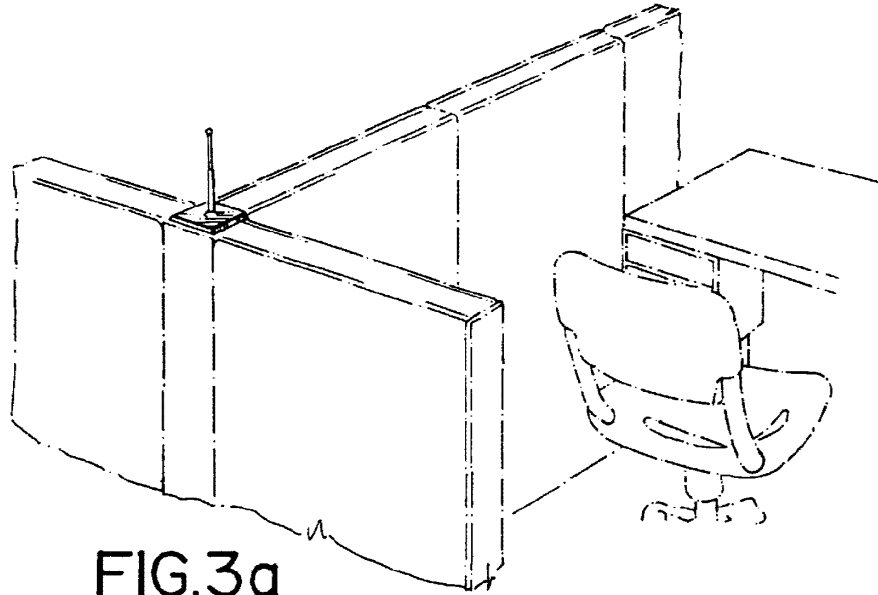


FIG. 3a

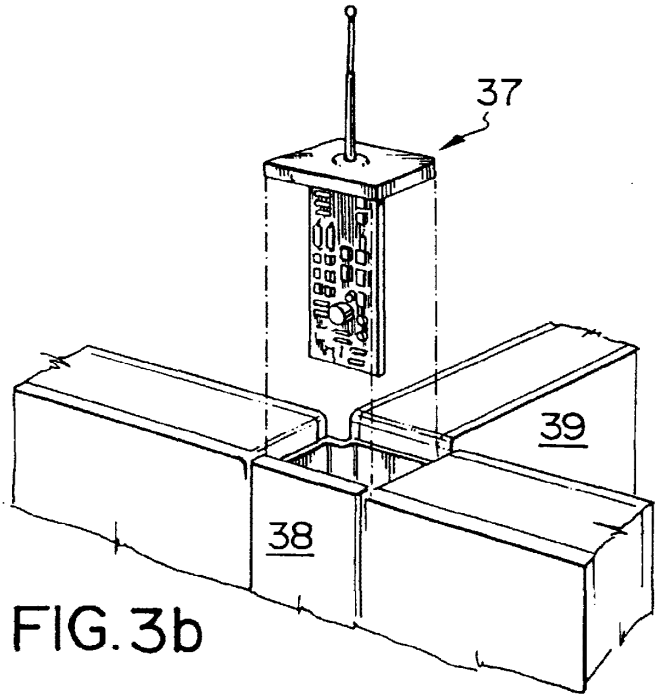
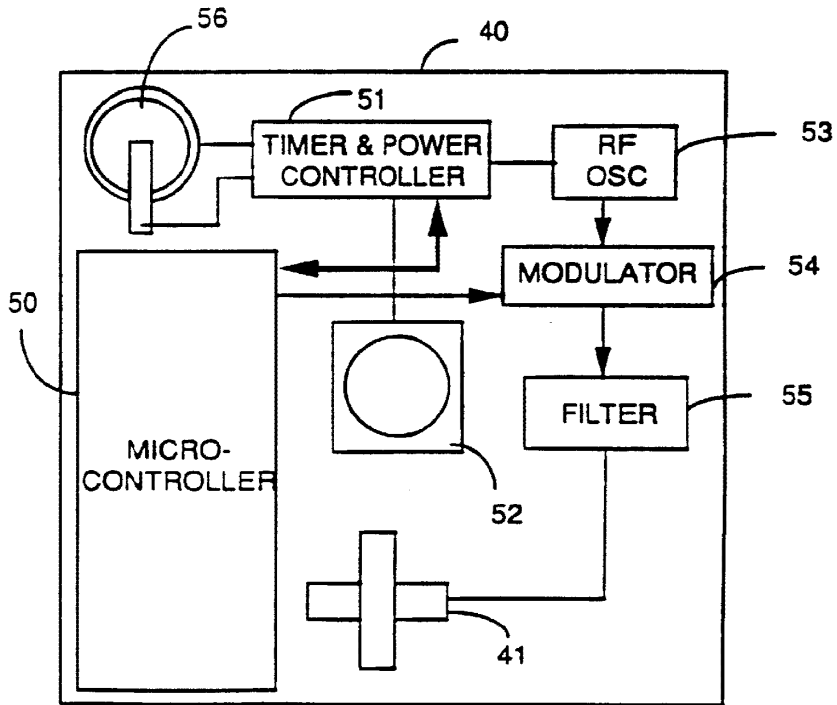
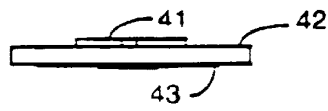
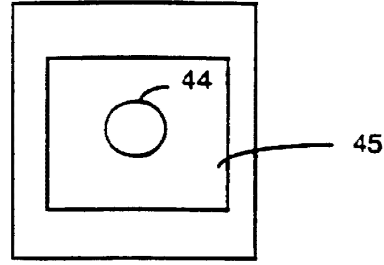
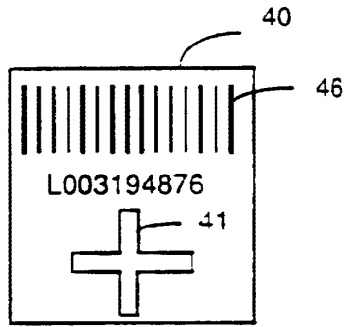


FIG. 3b



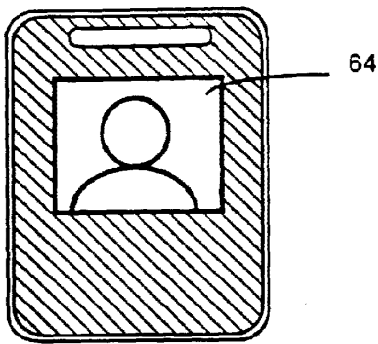


FIG. 6 a

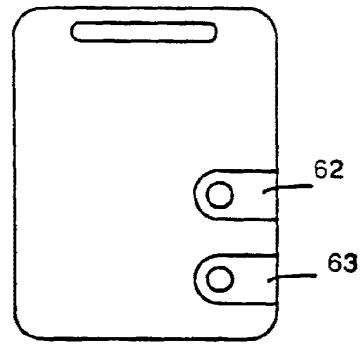


FIG. 6 b

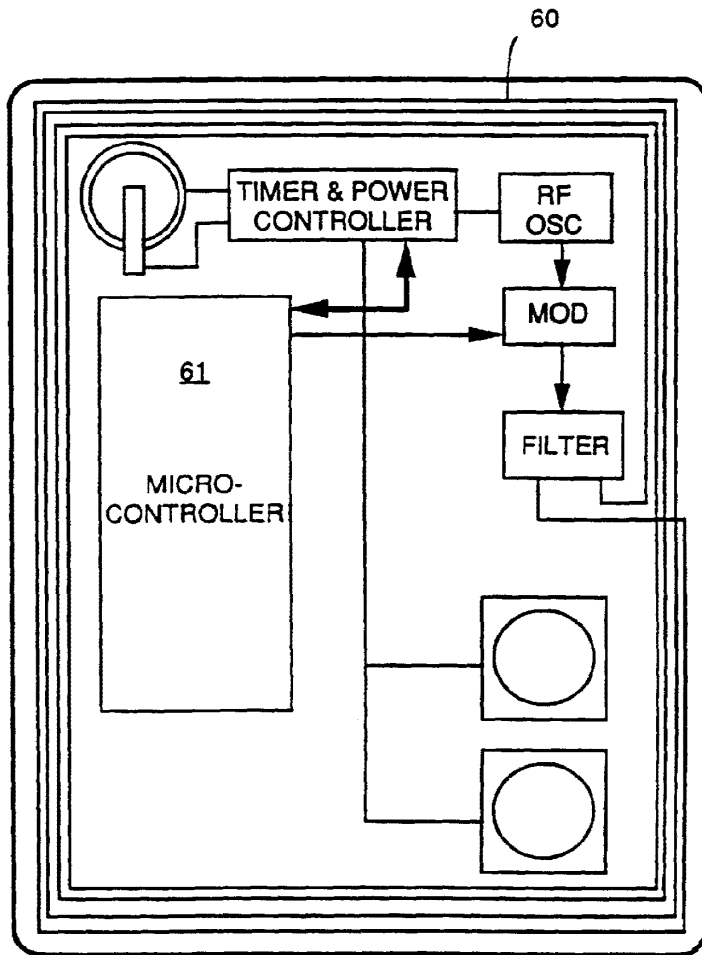


FIG. 7



(12) **EUROPEAN PATENT APPLICATION**

(43) Date of publication:  
**03.04.1996 Bulletin 1996/14**

(51) Int Cl.<sup>6</sup>: **G06F 1/16**

(21) Application number: **95306475.5**

(22) Date of filing: **14.09.1995**

(84) Designated Contracting States:  
**DE FR GB**

(30) Priority: **22.09.1994 US 310297**

(71) Applicant: **AT&T Corp.**  
**New York, NY 10013-2412 (US)**

(72) Inventors:  

- **Grewe, Anthony James**  
**Holmdel, New Jersey 07733 (US)**

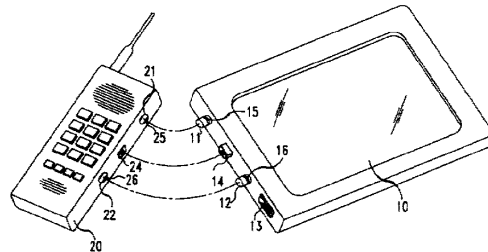
- **Ledbetter, Carl S., Jr.**  
**Summit, New Jersey 07901 (US)**
- **Kerwin, Michael**  
**West Orange, New Jersey 07052 (US)**
- **Partridge III, Waring B.**  
**Far Hills, New Jersey 07931 (US)**

(74) Representative:  
**Johnston, Kenneth Graham et al**  
**AT&T (UK) Ltd.**  
**5 Morningson Road**  
**Woodford Green Essex, IG8 OTU (GB)**

(54) **Communication apparatus**

(57) A versatile device is obtained with a PDA that includes means for cordless connecting to specialized accessories. The PDA can operate in its conventional mode, or it can be enhanced by interconnecting it with some or all of its accessories. In one embodiment, the PDA is combined with a cellular telephone that is adapted to physically mate with the PDA and form thereby a single integrated apparatus. In another embodiment, the PDA is combined with a landline telephone that is adapted to mate with the PDA and form thereby another single integrated apparatus. In a still another embodiment, the PDA (whether or not mated with a telecommunication device) is combined with a keyboard to form a laptop computer.

**FIG. 1**



**Description**

**Field of the Invention**

This invention generally relates to communication apparatus and, more particularly, to apparatus that at times performs telecommunication functions and at times performs processing functions.

**Description of the Prior Art**

The market offers a number of portable processing devices that assist people with their processing and information needs. In size order, for example, that includes calculators, organizers, personal digital assistants (PDAs), and notebook/laptop computers.

Calculators are, of course, limited to mathematical operations. Some of the more expensive ones can store calculation programs, but most do not.

Organizers are able to receive information, store it, process it, and display it. Typically, they are used for keeping track of appointments and the like. Organizers differ from calculators in that they handle text. Physically, they are small enough to fit in a man's pocket or a woman's purse. While in some sense these organizers can be thought of as computers, they nevertheless hold a separate niche in the market because of their small size and the collection of specialized software packages that they come with, including a specialized operating system. An operating system is a set of fixed programs that control the general operation of the organizer, including the manner of interaction with the user.

PDAs, which are much more versatile computers, are characterized by a relatively large touch sensitive screen which serves as both the input and output interface with the user. These PDAs boast a unique operating system that accomplishes most tasks by guiding the user through a sequence of selections. Typically, the operating system also includes an application for character recognition of script writing, and that allows the user to enter information that is not included in an anticipated set of possible inputs.

Lastly, there is the notebook/laptop computer that typically includes a keyboard, a screen, a memory, and a generalized operating system that allows the user to apply information directly, as well as execute application programs that guide the user through a sequence of selections.

In the realm of telecommunication, there is another portable device that is sweeping the market and that is the cellular telephone. Not unexpectedly, the art has attempted to combine computing and telecommunication, and there are devices now on the market that are basically a combination of the laptop computer and the cellular telephone.

What is needed, however, is more flexible devices that can operate as PDAs when that is desired, as laptop computers when that is desired, and as computers that

interact with cellular or landline telecommunication apparatus when that is desired.

**Summary of the Invention**

A versatile device is obtained, in accordance with the principles of this invention, with a PDA that includes means for connecting to specialized accessories. The PDA can operate in its conventional mode, or it can be enhanced by interconnecting it with some or all of its accessories. In one embodiment, the PDA is combined with a cellular telephone that is adapted to physically mate with the PDA and form thereby a single integrated apparatus. In another embodiment, the PDA is combined with a landline telephone that is adapted to mate with the PDA and form thereby another single integrated apparatus. In a still another embodiment, the PDA (whether or note mated with a telecommunication device) is combined with a keyboard to form a laptop computer.

**Brief Description of the Drawing**

FIG. 1 depicts a PDA and a wireless telephone that are adapted for physical and electrical connection to each other;

FIG. 2 presents the PDA and the wireless telephone of FIG. 1 mated to form an integral apparatus;

FIG. 3 shows, in exploded view, the means for physical and electrical coupling of the PDA to the wireless telephone;

FIG. 4 shows the elements of FIG. 3 in assembled form;

FIG. 5 presents a keyboard adapted for connection to a PDA to form a laptop computer;

FIG. 5A presents the details of the physical interconnection between the PDA and the keyboard;

FIG. 6 illustrates the electrical port of a PDA that allows it to interconnect with a landline telephone;

FIG. 7 illustrates a landline telephone adapted for interconnection with the PDA of FIG. 6;

FIG. 8 presents an arrangement where a PDA is connected to a landline telephone and concurrently to a wireless telephone and a keyboard; and

FIG. 9 is a schematic diagram of a simultaneous voice and data modem and its associated circuitry.

**Detailed Description**

FIG. 1 depicts a PDA 10 in a top-left handed view

and a cellular telephone 20 in a top-right handed view. Portions of a connector arrangement are shown on the left side of the PDA. They include coupling elements 11 and 12, activator element 13 and connector 14. The right side of the cellular telephone includes corresponding elements 21 and 22, and connector 24. More specifically, elements 11 and 12 are posts with grooves 15 and 16, respectively, and the posts protrude out of the left side surface of the PDA. Connector 14 is a multi-pin male connector that also protrudes from the left side surface of the PDA. Coupling elements 21 and 22 are cavities that are positioned in cellular telephone 20 to concurrently mate with posts 11 and 12, respectively, and sized for a reasonably tight fits of posts 11 and 12 within cavities 21 and 22. Cavities 21 and 22 include spring elements 25 and 26 that are arranged to engage with grooves 15 and 16 when posts 11 and 12 are fully inserted into cavities 21 and 22. Connector 24 is a female connector that is adapted to mate with connector 14 when posts 11 and 12 are inserted into cavities 21 and 22.

To couple cellular telephone 20 to PDA 10, posts 11 and 12 and connector 14 are aligned with cavities 21 and 22 and connector 24, respectively, and snapped, or forced, together. The result is a physically connected assembly that appears as a unitary PDA with an integral cellular telephone (or vice-versa). This is depicted in FIG. 2. The connection strength imparted by the posts and the connector allows the assembly of FIG. 2 to be handled as a single device.

Electrically in the cellular telephone, connector 24 is the very same connector that is currently available in many cellular telephones. The only difference, if any, is in the physical placement of the connector in the side of the telephone.

When cellular telephone 20 is an analog telephone, then connector 14 is coupled to a modem within PDA 10. When cellular telephone 20 is a digital telephone, then a modem is not required. The exact electrical interface between PDA 10 and telephone 20 is not a part of this invention, so it is not described here in detail. Suffice it to say that the interface must satisfy the requirements of both the telephone and the PDA. U.S. Patent 5,127,041, issued June 30, 1992, illustrates one approach.

FIG. 3 presents an exploded view of connector 30, and FIG. 4 shows connector 30 in its assembled mode. The connector of FIG. 3 is merely illustrative, of course. Other connector arrangements are also possible and are within the scope and contemplation of this invention.

The connector of FIGS. 3 and 4 comprises the two primary components 31 and 36, springs 41 and 42, and housing 40. Member 31 is characterized by posts 11 and 12 extending from one surface thereof and connector 14 attached to the same surface. That same surface also includes two blind bores 32 and 33 with a diameter that is large enough (in diameter) to allow springs 41 and 42 to be inserted into the bores, and shallow enough to merely maintain the springs in position. Opposite the sur-

face on which posts 11 and 12 are found there are ramp surfaces 34 and 35.

Member 36 is characterized by corresponding ramp surfaces 37 and 38, and an activator element 13 which, advantageously, is a capped post that is screwed into the body of member 36.

Housing 40 is a molded part of the housing of PDA 10 and it includes appropriate openings in its outside wall to allow posts 11 and 12, connector 14 and the post portion of activator element 13 to extend through the openings.

The general principle of the FIGS 3 and 4 connector is that member 31 is situated in housing 40 either in a retracted position or in an extended position (in FIG. 4 it is depicted in the extended position). In the retracted position, posts 11 and 12 and connector 14 do not extend outside housing 40 (i.e., are flush with the outside wall of housing 40), and member 31 is kept in this position by the force of springs 41 and 42 acting to separate member 31 from the outside wall of housing 40. In the extended position, ramp surfaces 37 and 38 are engaged with ramp surfaces 34 and 35, respectively, to push member 31 toward the outer wall of housing 40, against the force of springs 41 and 42. In this extended position, posts 11 and 12 and connector 14 extend through the outer wall of housing 14. Such extending allows the connection of cellular telephone 20 to the housing of PDA 10, as described above. Member 36 is caused to engage its ramps 36 and 37 with ramps 34 and 35 by applying a force to the cap of activator element 13 to slide member 36 in the direction of the arrow marked "extend" in FIG. 4. Correspondingly, ramps 36 and 37 are disengaged from ramps 34 and 35 by sliding element 36 in the direction marked "retract".

In addition to converting the PDA of FIG. 1 to a communicating processor unit by coupling to it the cellular telephone, it is desirable to enhance the PDA by allowing it to support a keyboard. That is, while it is expected that many applications will be well served through the touch screen interface of the PDA, it is also anticipated that some applications would be better served when a "full fledged" keyboard is included. To that end, FIG. 5 shows a PDA that includes two somewhat cylindrical recesses 17 at two corners of the PDA and a connector 16. The cylindrical recesses end with holes 18.

FIG. 5 also illustrates a keyboard that is adapted for connection to holes 18 and to connector 16. More specifically, FIG. 5 presents a keyboard 50 that includes, at each of two end corners, a connection assembly for connecting to cylindrical recesses 17 and holes 18. Each assembly includes a slightly flexible protrusion 52 with a cylindrical end portion 51 that is at 90 degrees with respect to protrusion 52. End portion 51 fits into hole 18 and pivots within it to allow keyboard 50 to swing into an open position or a closed position. In the closed position the keyboard covers the display of the PDA. In the open position, a connector 53 swings into and mates with connector 16, thereby making an electrical connection be-

tween keyboard 50 and PDA 10.

Keyboard 50 includes conventional keys such as key 55, function keys such as key 54, a track ball 56, and a floppy disk drive (not shown) coupled to port 57. It could also include a hard disk (also not shown). Port 57 could alternatively comprise a PCMCIA connector to which various other devices can be connected, etc.

While it is novel to have these computer accessories in the keyboard housing, particularly in the arrangement disclosed herein where those accessories are not likely to be used unless a "laptop" computer configuration is desired, the electrical connection between those accessories and the processor within PDA 10 is completely conventional. The same connections that are normally made to these accessories are made via connectors 16 and 53 in the FIG. 5 arrangement.

While it will be very useful to allow users to travel with PDA 10 and to even allow such users to communicate data to and from PDA 10 via cellular telephone 20, it is also realized that PDA 10 can be used in the office, where cellular telephony need not be used. Moreover, in an office environment it would be useful to operate the PDA from an external power source to save on battery power. To that end, PDA 10 is provided with a connector strip 80 on a face of PDA 10 that, illustratively, is opposite the face where the keyboard is coupled. Strip 80, shown in FIG. 6, includes enough contacts to provide both power and data connectivity to a landline telephone. Looking at FIG. 6, note might be taken of handle 83 which is included for carrying convenience.

FIG. 7 illustrates a novel design for a landline telephone 90 with a housing that is adapted to receive, and operate with, a PDA such as the one illustrated in FIG. 6. In particular, the FIG. 7 telephone includes a tray, or receptacle, 82 that is fashioned to hold PDA 10, whether connected to keyboard 50 or not. Tray 82 includes a connector strip 81 that is positioned in the tray to mate with contacts in strip 80 when PDA 10 is in the tray.

Lastly, FIG. 8 illustrates a landline telephone with a housing which includes a tray that is large enough to hold PDA 10 when it is coupled to cellular telephone 20.

It would be obviously advantageous for PDA 10 to automatically recognize when it is connected to the various accessories disclosed above and modify its operating style accordingly. This capability is easily achieved by detecting signal conditions at connectors 14, 16 and 80. A number of such capabilities are presented below for illustrative purposes, and others are easily visualized.

FIG. 9 is a schematic diagram of circuitry between connector 81 and the terminals adapted for connection to the central office. In FIG. 9, the landline telephone is connected to the central office POTS line through a simultaneous voice and data (SVD) modem 95, such as the one disclosed in copending application Serial No. 08/076505, filed June 14, 1993, and titled "Simultaneous Analog and Digital Communication". A digital signal port represented by lines 91 and 92 is also connected to the central office through SVD modem 95.

To describe this modem in a nutshell, it modulates applied digital signals and analog signals onto a carrier. More specifically, it forms symbols from groups of bits, maps the symbols onto two signals, samples the analog signal and also maps the analog signals onto the two signals. It then modulates the mapped signals with two orthogonal carriers, sums the result and outputs the sum. All this is done under command of a modem controller within modem 95 that is also sensitive to signal conditions on the telephone line side, on the digital port, and on the analog port.

In particular, the controller detects dial tone and ringing (as all modem controllers do), it detects the presence of digital signals on the digital port (also as all modems do), and it detects an "off hook" condition on the analog port. The latter is accomplished by including a voltage source and current detection means in the controller, to emulate a central office. In the FIG. 9 embodiment, sensing of an "off hook" condition in telephone 90 can be done outside the controller because a power supply 93 is provided for the digital port. Thus, dc power is supplied to telephone 90 through lead 94 and resistor 96, and that dc power is isolated from the modem by capacitors 97 and 98. The "off hook" condition is detected by amplifier 99 having two inputs that straddle resistor 96. The output of amplifier 99 is applied to the controller within modem 95.

Power supply 93 also supplies power to the modem and to connector strip 81. The path to strip 81 also includes a current sensor, comprising series resistor 61 that straddles the two inputs of differential amplifier 62 that applies a control signal to modem 95. A current through resistor 61 that exceeds a predesigned threshold switches amplifier 62 from "off" to "on", indicating that PDA 10 is resting on its tray. It does not mean, of course, that data is flowing through leads 91 and 92, but it does suggest to modem 95 that it should become sensitive to the presence of data.

FIG. 9 also includes accessories 65 which are powered by supply 93 and which interact with PDA 10 via connector strip 81. Accessories 65 can be one or more of the devices that are commonly connected to a computer bus, such as a mouse, a floppy disk, a hard disk, a PCMCIA connector port, semiconductor memory, CD ROMS, etc. The connection of these elements to the processor within PDA 10 is completely conventional.

The above description illustrates actions taken by the apparatus associated with telephone 90, i.e., by the apparatus between strip 91 and the port connecting to the central office. On the PDA side, the interactions are with strip 80, with connector 16 and with connector 14. The most basic interactions that PDA 10 may wish to include is the ability to automatically realize that cellular telephone 20 is connected, that keyboard 50 is connected, and that landline telephone 90 is coupled. Additionally, it may be useful to know whether any of the connected telephones go "off-hook". With each of these pieces of knowledge, the operating system of PDA 10 adjusts

itself to a different mode of operation, and may even trigger application software.

For example, when the PDA rests in the tray of telephone 90 and a power supply voltage is supplied to PDA 10 from power supply 93 through strip connectors 81 and 80, it is advantageous for this power source to power the PDA itself, to power the accessories in keyboard 50, and to power, and/or charge the internal battery of cellular telephone 20. This is easily achieved by connecting the power leads in strip 80 to power leads in connectors 14 and 16.

To automatically determine that cellular telephone 20, keyboard 50 and/or telephone 90 are connected to PDA 10, all that is necessary is to detect the presence of a known signal, or voltage level at the respective terminals. Clearly, looking at the power leads coming from connector strip 80 is a simple solution, and a similar solution can be had in with other connectors. If there is no inherent dc voltage that can be derived from connectors 24 and 53 (when they are coupled to connectors 14 and 16, respectively), one can be created by applying the battery voltage of PDA 10 to one pin of connector 24, for example, shorting that pin to another pin, and observing the voltage at a corresponding pin in connector 14.

Lastly, to recognize an "off-hook" state of telephone 90, lead 66 (in FIG. 9) couples the output of amplifier 99 to strip 80 and to PDA 10, and the voltage on that lead provides the necessary information.

The entire operating system of PDA 10 can be altered when any of the above-considered elements are connected to PDA 10. It is expected, however, that the biggest change in the operating system will take place when a keyboard is connected to the PDA, converting the PDA to laptop computer.

#### Claims

1. Apparatus including a personal digital assistant (PDA) that contains a housing, a processor in said housing and an input/output device arrangement in said housing coupled to said processor for inputting data to, and outputting data from, said processor, the improvement comprising:
  - first connector in said housing for cordless physical coupling of said connector to a telephone and for coupling said connector to said process; and
  - first means, integral to said housing, for physically connecting said housing to a telephone to effectively form a single physical unit that comprises said housing and said telephone.
2. The apparatus of claim 1 wherein said telephone is a wireless telephone, or a landline telephone.
3. The apparatus of claim 2, wherein the wireless telephone includes a housing with a connector adapted to mate with said first connector and a

means for physically connecting the housing of the wireless telephone to the housing of the PDA, said wireless telephone having its connector engaged with said first connector and its means for physically connecting engaged with said first means for physically connecting.

4. The apparatus of claim 2 or 3, wherein said means for physically connecting comprises at least one spring-action fastener in said housing.
5. The apparatus of claim 2, wherein the landline telephone includes a housing that includes tray means for accepting the PDA of claim 1.
6. The apparatus of claim 5, where said tray includes a connector adapted for connecting said landline telephone to a PDA.
7. The apparatus of claim 6, wherein said connector included in the tray is coupled to said first connector through direct pressure contact.
8. The apparatus of claim 6, wherein said connector includes contacts for providing dc power to the PDA.
9. The apparatus of claim 5, wherein said telephone includes a modem, for example a simultaneous voice and data modem.
10. The apparatus of claim 6, wherein the landline telephone includes memory connected to the connector and adapted for interaction with the PDA.
11. The apparatus of claim 1, further comprising a second connector in said housing, where the first connector is adapted for physical connection to a wireless telephone and the second connector is adapted for physical connection to a connector in a housing of a landline telephone.
12. The apparatus of claim 11, further comprising a landline telephone with a housing that includes tray for accepting the apparatus of claim 13 and a third connector, where said second connector is coupled to said third connector.
13. The apparatus of claim 12, wherein said second connector and said third connector are arranged to mate and make electrical contact by the mere placement of said apparatus of claim 14 in said tray.
14. The apparatus of claim 11, further comprising a wireless telephone that includes a housing with a connector adapted to mate with said first connector and a means for physically connecting the housing of the wireless telephone to the housing of the PDA, said wireless telephone having its connector engaged



with said first connector and its means for physically connecting engaged with said first means for physically connecting present in the PDA, thereby forming a unitary, integral apparatus.

5

15. The apparatus of claim 14, further comprising a landline telephone with a housing that includes tray for accepting the apparatus of claim 14 and a third connector, where said second connector is coupled to said third connector.

10

16. The apparatus of claim 1, further comprising a second connector in said housing for coupling a keyboard interface to said processor, and second means, integral to said housing, for physically connecting said housing to said keyboard interface to effectively form a single physical unit that comprises said housing and said keyboard interface.

15

17. The apparatus of claim 16 wherein said second means includes a swivel mechanism to allow said keyboard interface means to cover said touch sensitive screen.

20

18. The apparatus of claim 16 further comprising a keyboard interface unit coupled to said second connector.

25

19. The apparatus of claim 18 wherein said keyboard interface unit either includes a PCMCIA connector electronically coupled to said second connector, or includes memory, for example a hard disk memory, coupled to said second connector.

30

35

40

45

50

55

6

FIG. 1

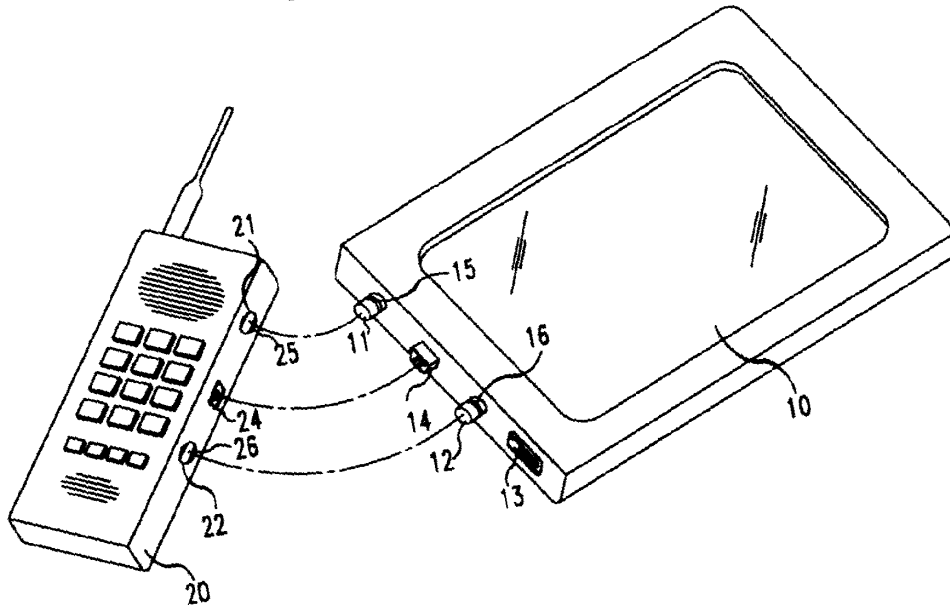
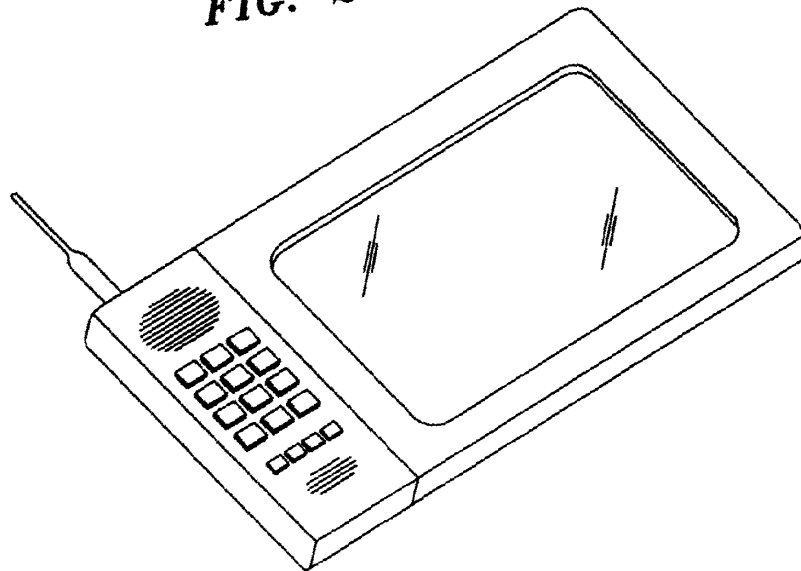
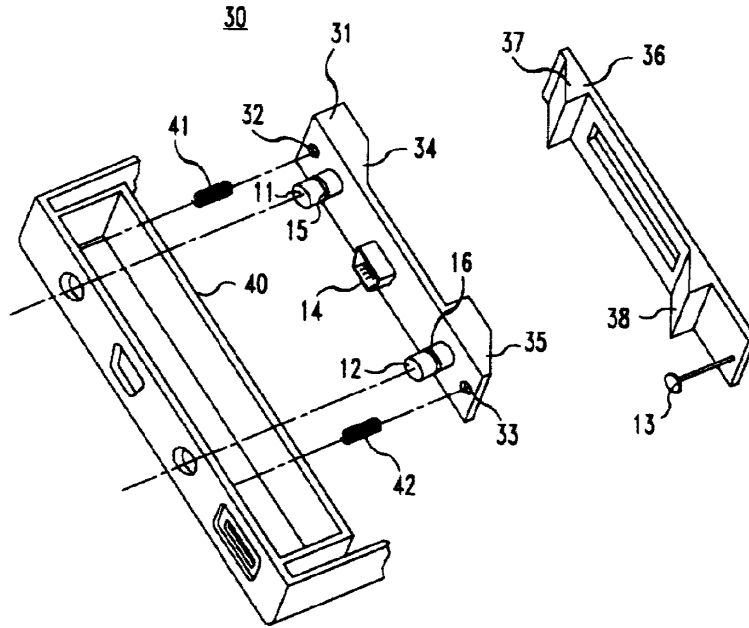


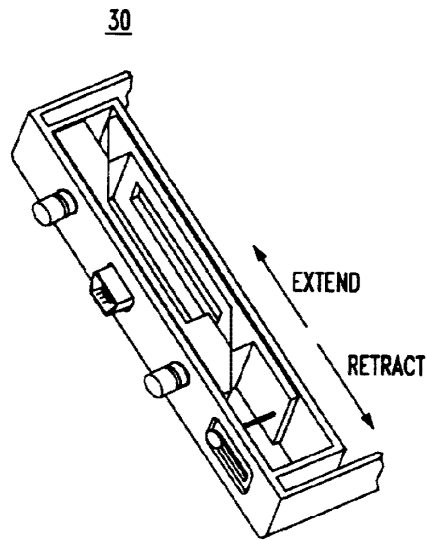
FIG. 2

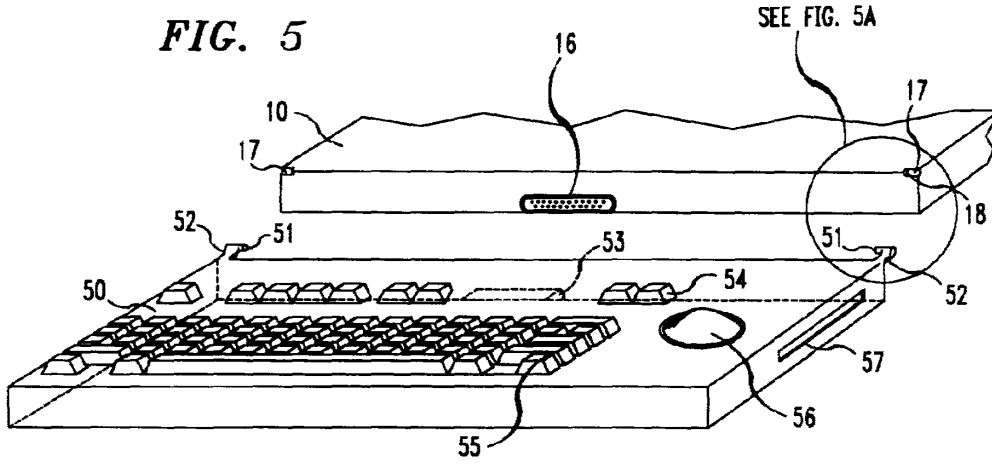


**FIG. 3**

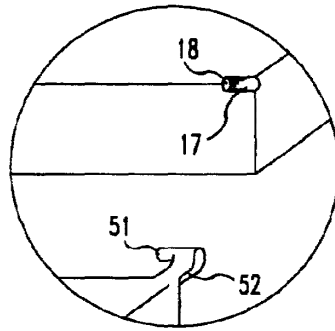


**FIG. 4**

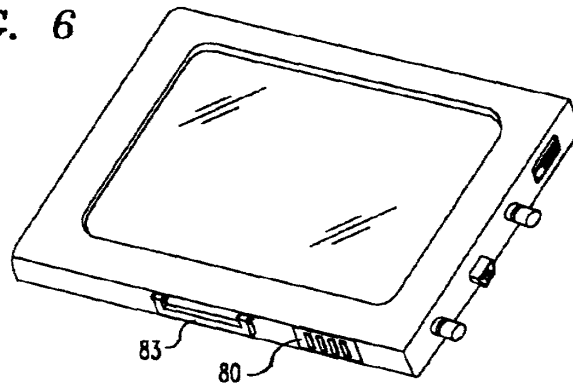




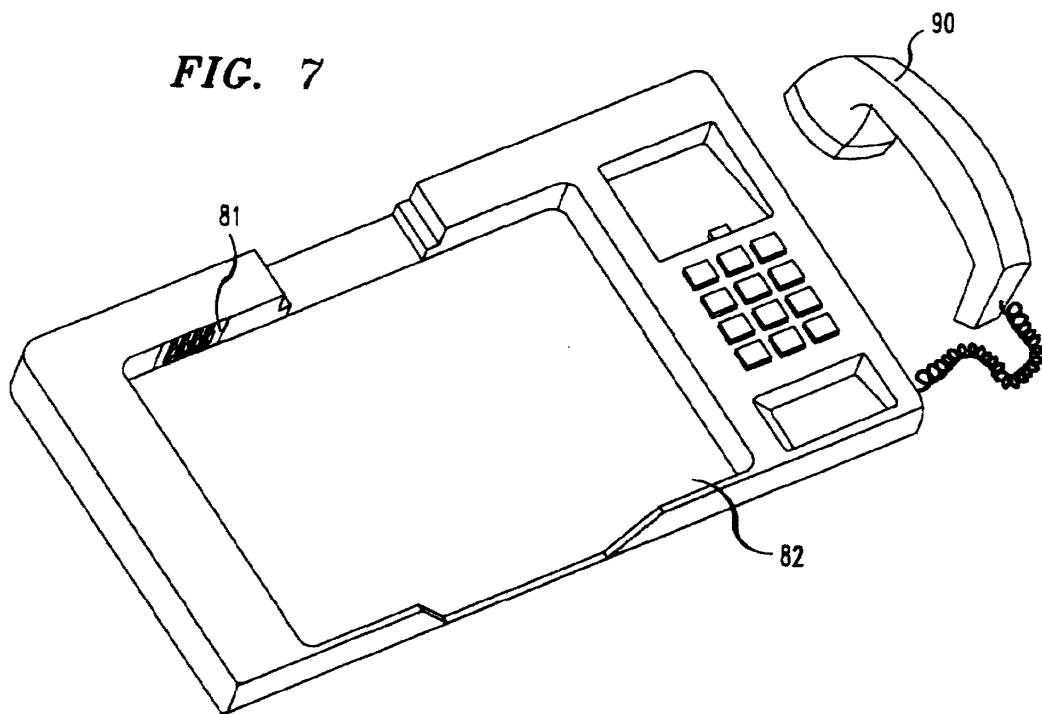
**FIG. 5A**



**FIG. 6**



**FIG. 7**



**FIG. 8**

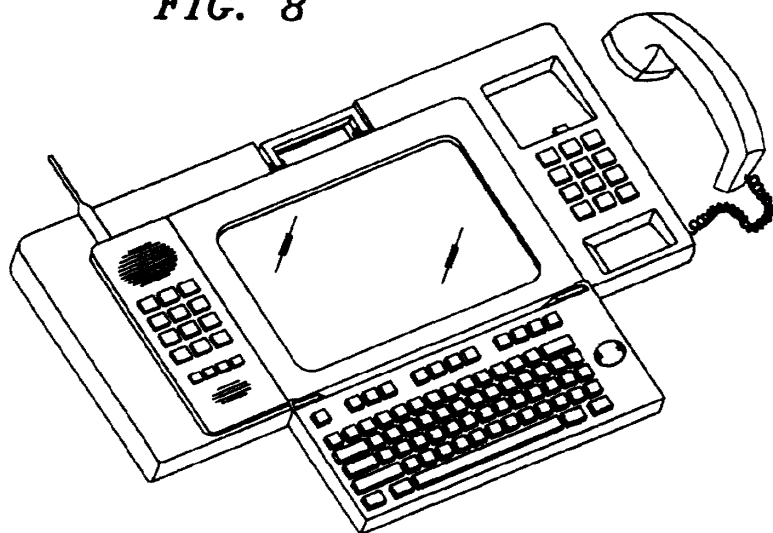
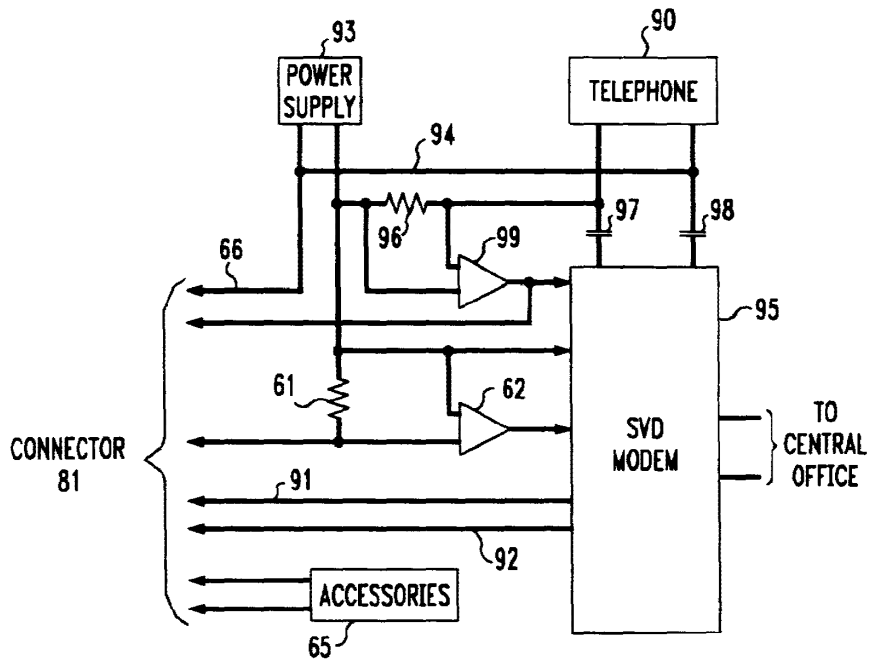


FIG. 9





(11) **EP 0 858 202 B1**

(12) **EUROPEAN PATENT SPECIFICATION**

(45) Date of publication and mention of the grant of the patent:  
**10.10.2007 Bulletin 2007/41**

(51) Int Cl.:  
**H04M 1/274 (2006.01) H04M 1/57 (2006.01)**

(21) Application number: **98300975.4**

(22) Date of filing: **10.02.1998**

(54) **A graphic user interface for use with a telephone directory**

Graphische Benutzerschnittstelle zum Gebrauch mit einem Fernsprechverzeichnis

Interface utilisateur graphique pour usage avec un répertoire téléphonique

(84) Designated Contracting States:  
**DE FR GB**

(30) Priority: **10.02.1997 US 798521**

(43) Date of publication of application:  
**12.08.1998 Bulletin 1998/33**

(73) Proprietor: **Nokia Corporation**  
**02150 Espoo (FI)**

(72) Inventors:  
• **Rosecrans, Michael W.**  
**Santee,**  
**California 92071 (US)**  
• **Simon, Mitchell**  
**San Diego,**  
**California 92130 (US)**

(74) Representative: **Plotrowicz, Pawel Jan Andrzej et al**  
**Venner Shipley LLP**  
**Byron House**  
**Cambridge Business Park**  
**Cowley Road**  
**Cambridge CB4 0WZ (GB)**

(56) References cited:  
**EP-A- 0 493 084 WO-A-94/30023**  
**GB-A- 2 306 078**

- **PATENT ABSTRACTS OF JAPAN vol. 1997, no. 06, 30 June 1997 (1997-06-30) & JP 09 036945 A (SONY CORP), 7 February 1997 (1997-02-07) -& US 5 778 054 A (KIMURA YUJI ET AL) 7 July 1998 (1998-07-07)**
- **PATENT ABSTRACTS OF JAPAN vol.011, no.245 (E-531), 11 August 1987 (1987-08-11) & JP 62 057347 A (NIPPON TELEGR & TELEPH CORP), 13 March 1987 (1987-03-13)**

Note: Within nine months from the publication of the mention of the grant of the European patent, any person may give notice to the European Patent Office of opposition to the European patent granted. Notice of opposition shall be filed in a written reasoned statement. It shall not be deemed to have been filed until the opposition fee has been paid. (Art. 99(1) European Patent Convention).

**EP 0 858 202 B1**

### Description

**[0001]** The present invention relates to telephones and, more particularly, to telephones, such as cellular phones, containing electronic phonebooks and a Graphic User Interface for such phonebooks.

**[0002]** In the new wireless world, people do not think of connecting with a place, a phone number, or a name, such as found in a phone directory, but rather with a particular person or entity. Still, existing phone equipment for the most part requires directory-type dialing or data entry in memory for normal functioning instead of being more compatible with the present mobile, intuitive society. Also, currently, computers, the Internet, and PDAs have become more icon-based, so that cellular phone and PCS handsets should be more graphically oriented, particularly in view of the availability of Dot Matrix Displays which can allow cell phones to display graphics, logos, and black & white pictures.

**[0003]** Current telephones, including cellular phones, have the capability of storing names and numbers in an electronic phonebook, but the user must manually enter the information and then remember which person or place is related to the name or number when accessing the information later. The user may get some respite from number entry with this technology since the phone can be automatically dialed using the information if it is properly recalled. In this regard, present SMS technology allows for the ability to send an alphanumeric message tied to a phone number, but in general there is a need for a more user-friendly format with more use of graphics and reduced burdensome user input in sending and managing messages and information.

**[0004]** Present phone technology is still not sufficiently user-friendly and digital cellular phones need to utilize greater graphical capabilities to offer enhanced, easier, informative, and more personal service.

**[0005]** EP-A-0493084 describes a communication apparatus including a storage unit for storing image information associated with a distant station, an instruction unit for instructing a read operation of image information stored in the storage unit, a display unit for reading out and displaying a plurality of pieces of image information instructed by the instruction unit and a communication control unit for generating a call to one of distant stations corresponding to the pieces of image information displayed on the display unit. A received image signal and a selection signal for a telephone number of a calling party may be registered in correspondence with each other. An operator selects an image to make a telephone call to a calling party of the image using a telephone number corresponding to the image. In this manner, an image of a party to be called can be visually recognised before calling, and a calling operation can be reliably performed to a required party with a simple operation.

**[0006]** US-5778054 describes a communication terminal apparatus receiving and storing access information and video information corresponding to the access infor-

mation. The video information is retrieved from storage for display to a user. A selection of one video information is received from a user and one access information corresponding to the one video information is retrieved from storage.

**[0007]** The present invention seeks to provide an improved graphic user interface, a telephone with a graphic user interface and a method of using a graphic identifier.

**[0008]** According to the present invention there is provided a graphic user interface for use with an electronic phonebook in a telephone, such as a cellular phone, comprising means for tying phone numbers in the phonebook to respective graphic identifiers, means for displaying the graphic identifiers on a display screen of the telephone, means for selecting a graphic identifier on the displaying means; and means, responsive to the selecting of a graphic identifier on the displaying means, for activating the telephone to call the respective tied phone number, means for storing and tying additional graphical information to the phone numbers in the phonebook along with the respective graphic identifiers and means, responsive to the completion of a call to the respective tied phone number, for sending the additional graphical information and tied phone numbers to the telephone at the respective tied phone number.

**[0009]** The interface may further comprise means for scrolling the respective graphic identifiers for successive display on the displaying means. The selecting means may comprise means, coupled to the phonebook, for accessing tied phone numbers therein, SEND means for actuation by a phone user when a respective graphic identifier to be selected is displayed and producing a signal in response to being actuated and means, coupled to the accessing means and the activating means and responsive to the signal produced by the SEND means, for communicating the phone number tied to the selected respective graphic identifier to the activating means when the SEND means is pressed. The tying means may comprise a database with fields for storing pixel information of the graphic identifiers, and with fields for storing the respective tied phone numbers and means for accessing both the graphic identifiers and the respective tied phone numbers by the same index into the database. The tying means may comprise a database record holding both a graphic identifier and its respective tied phone number.

**[0010]** According to the present invention there is provided a telephone comprising an electronic phonebook for storing a plurality of phone numbers tied to respective graphic identifiers and additional information tied to the respective graphic identifiers, a display screen for displaying the graphic identifiers, means for producing a scroll signal for scrolling the graphic identifiers on the display screen and interface means for controlling the providing of the graphic identifiers from the phonebook to the display screen in response to the scroll signal produced by the scrolling means, the interface means comprising the interface, wherein the means for activating the telephone to call the respective tied phone number



further comprises means for sensing when a call has been completed and sending a connect signal, indicating a phone is available for receiving at the phone number called, to the interface and the interface further comprises means, responsive to the connect signal, for sending the additional information tied to the graphic identifier displayed on the display screen to the available phone.

[0011] The activating means may comprise a micro-processor. The interface means may further comprise means for storing the graphic identifiers. The electronic phonebook may comprise means for storing the graphic identifiers.

[0012] According to the present invention there is further provided a method of using a graphic identifier with an electronic phonebook in a telephone, such as a cellular phone, to activate a phone call to a tied phone number, comprising tying phone numbers in the phonebook to respective graphic identifiers, displaying the graphic identifiers on a display screen of the cellular phone, selecting a graphic identifier on the display screen and while the selected graphic identifier is being displayed on the display screen, activating the phone to call the respective tied phone number, storing and tying additional graphical information to the phone numbers in the phonebook along with the respective graphic identifiers and in response to the completion of a call to the respective tied phone number, sending the additional graphical information and tied phone numbers to the phone at the respective tied phone number

[0013] The additional graphical information may comprise advertising material. The step of selecting may comprise actuating a phone element when a respective graphic identifier to be selected is displayed and producing a signal in response to the phone element being actuated, accessing tied phone numbers from the phonebook; and in response to a signal produced by the phone element being actuated, communicating the phone number tied to the selected respective graphic identifier for activating the phone to call the respective tied phone number. The phonebook may comprise a database with fields for storing pixel information of the graphic identifiers, and with fields for storing the respective tied phone numbers, and wherein the method comprises accessing both the graphic identifiers and the respective tied phone numbers by the same index into the database. The method may comprise the phonebook holding both a graphic identifier and its respective tied phone number in a database record. The method may comprise scrolling the respective graphic identifiers for successive display on the display screen.

[0014] Embodiments of the present invention will now be described, by way of example, with reference to the accompanying drawings, of which:

Figure 1 is a perspective view illustrating an example of a cellular telephone for use with the present invention; and

Figure 2 is a block diagram illustrating an exemplary set of operating components and their cooperation for producing a call.

5 [0015] The present invention involves the provision of a Graphic User Interface for use with telephones containing electronic phonebooks, which Interface links graphical information, e.g., a graphic image or logo or picture, stored in the phonebook to one or more selected  
10 phone numbers, also stored in the phonebook, to enable the calling of a number using the graphic image and the sending of related graphical information with linked numbers to the selected phone numbers. A preferred embodiment of Graphic User Interface for electronic phone-  
15 books in accordance with the invention draws upon three technologies used in existing digital cellular phones. The three are:

1. Electronic Phonebook technology whereby current cellular phones can store names and/or numbers that are manually entered into a phone memory or database by a user;
2. Digital messaging technology whereby a phone can communicate with other phones with an alphanumeric message tied to a phone number; and
- 25 3. Dot Matrix Display technology whereby cell phones are able to display graphics, logos, and "black & white" pictures.

30 [0016] Through the linking and combining of features of these three technologies the invention enables users, companies, and advertisers to use graphic images for making phone calls and to exchange graphics, that are tied to phone numbers, and to store this exchanged  
35 information in the memory of their phones. An example of a phone for use with the invention is shown in Figure 1 in the form of a cellular phone 10, including a display 11 adapted, by means of an Interface unit 12, to present graphic images 13. The images 13 are graphic identifiers  
40 and may be stored in a separate Graphic phonebook in the Interface unit 12, or in the phone's electronic phonebook 14, along with tied phone numbers and optionally other tied information. This tying may be accomplished  
45 by means of an information database with fields for storing pixel information of the image and fields for storing the phone number or numbers and other tied information, with both the image and phone numbers being accessed  
50 by the use of the same value or index into the database. Alternatively, one database record may hold both an image's pixel information and the phone numbers and other information tied to that image.

[0017] A user wishing to make a phone call, for conversation or for sending graphical/phone number information to another, scrolls through the different images  
55 or logos or pictures 13 on the phone display 11 for one that identifies the location or person to be called. Scrolling may be accomplished by pressing a key or keys on a keypad 17 to read forwards and backwards through the

records in a database stored in the Graphic phonebook of the Interface unit 12 or a database of the electronic phonebook 14, and displaying the image fields 13 of the records read on the display 11. Each key press on keypad 17 may index an increase or a decrease in the order of the database records. This scrolling may be used to merely display a stored image for viewing purposes, such as a picture of a family member; but, more importantly, it also may be used for displaying a series of graphic identifiers 13 which have related stored images and numbers. Accordingly, each graphic identifier 13, having one or more tied phone numbers stored with it in a memory in Interface unit 12 or in the phonebook memory, may be viewed until the one that identifies the location or person to be called appears. Selection of the desired location or person is then accomplished, when the graphic identifier 13 associated with or corresponding to a desired location or person is displayed while scrolling, by ceasing scrolling and activating the phone. The phone may be activated by pressing the SEND button 15 while the associated graphic identifier 13 is being displayed, which causes the Interface unit 12 to activate the phone circuitry 16 to place a call to the location or person without other involvement of the user with the tied phone number. Thus, a user is able to call another person or location without having to remember or to dial the phone number of that person.

**[0018]** Figure 2 is a block diagram showing an exemplary set of operating components and their cooperation for producing a call. The Interface unit 12 contains a microprocessor 18 and an optional memory 19 for storing graphic identifiers and, optionally, one or more tied phone numbers and/or graphics with them. The microprocessor 18 has inputs from memory 19 and the phonebook memory 14' as well as from keypad 17, which controls the image information from memory 19 and/or memory 14' provided to display 11. An input from SEND key 15 will produce an appropriate output from microprocessor 18 to the phone circuitry 16 to call the phone number tied to the graphic identifier being viewed on display 11. Thus, the number to be called is selected by viewing the graphic identifier tied to the desired number and pressing the SEND key 15.

**[0019]** Once the sending and receiving phones are connected for transmission, a conversation may be held, or a message sent, or information may be forwarded from the sending phone's memory. The information sent to the receiving phone or phones may include the graphic identifier and/or other graphics, along with further tied phone numbers, for immediate selection at, or storage in a database in, the receiving phone. For example, as indicated in Figure 2, when the call has been completed, the phone circuitry 16 can provide a signal to the microprocessor 18 to send or download appropriate stored information, such as graphical information and/or phone numbers, from memories 19 and/or 14' to the receiving phone at the number that has been called. Consequently, the receiving phone can be enabled to perform storage and display and graphic identifier dialing in the manner

of the sending phone without the need for any other data entry by the receiving phone user.

**[0020]** The existing technologies are preferably combined in the manner of the invention by a software-based Interface unit 12 that provides for the creation of a Graphic phonebook file or database, in memory 19 or memory 14', which enables the graphic identifiers to be tied to one or more phone numbers in an electronic phonebook accessible through the Interface. In addition, this database may tie the graphic identifiers to other graphics and phone numbers which may be sent, using the Interface, to other phone users for incorporation in other like databases in their Graphic electronic phonebooks. Further, the graphic identifiers can be tied to messages and other information. As a result, graphic images can be used as location holdings for further information, as well as phone numbers. The Graphic electronic phonebooks may be permanent in nature or location-specific temporary phonebooks.

**[0021]** A specific example of the use of communicating phones incorporating an Interface in accordance with the invention is as follows. Joe and Jane, who have appropriately equipped phones, meet each other and want to keep in touch. Each has a personal picture with a tied phone number in their Graphic User Interface electronic phonebooks. Joe transmits or downloads his picture/number to Jane for storage in her Graphic phonebook and she transmits or downloads her picture/number to Joe for like storage. Then, when Joe wishes to call Jane, he scrolls through the pictures of people stored in his Graphic phonebook until Jane's picture is displayed, whereupon he presses SEND and the phone calls Jane's number. Neither need remember the phone numbers or get involved in dialing them. The pictures and numbers may be part of a business card stored electronically, or a driver's license or other identification means so stored, that can be readily displayed on display 11 for this purpose.

**[0022]** Another example of how graphic identifiers may be used to exchange more detailed information is as follows. Advertisers and service or merchandise providers can utilize graphic identifiers in an exceptional way to communicate with people in a particular target area. For instance, a traveler entering a new geographic area, and indicating his presence there by means of his phone, can be sent several graphics, such as a Car Rental icon, an Hotel icon, a Restaurant icon, and/or an icon representing some other available service or merchant, from an advertiser database to his suitably equipped cellular phone. The transmitted information may be stored in a Graphic location-specific temporary phonebook in the traveler's phone. The graphic images or icons can be hierarchically arranged in categories with multiple entries under each category.

**[0023]** By selecting and pressing on any of the received icons on the Interface display, the traveler can display or receive additional information and/or directly call a Customer Service Representative at a desired

service location. Upon contacting a Representative, the traveler can discuss available choices, pictures of, or information on, which may be prestored with the icon in his Graphic phonebook for viewing and consideration during the conversation. Further graphical information may also be transmitted. The traveler may keep the icons and information in his location-specific temporary phonebook throughout the duration of his trip to be able to intuitively reach those services that are important to him, and then erase the phonebook when the trip is over.

**[0024]** In comparison to the known pagers that use icons to reach different parts of stored information, i.e., a phone for phone numbers, a book for addresses, the invention enables a user to utilize the airwaves to get detailed and related information into a cellular phone without having to go to the time and trouble of keying it in himself. Moreover, once the information reaches the cell phone, it is live, in the sense that it too activates the phone to make a call as the phone number is intuitively tied to the information.

**[0025]** The sender can also utilize graphical representations or icons to obtain selected responses to an inquiry. Recipients, having downloaded suitable graphical information in memory, can answer an inquiry by selecting one of the icons or replying with a selection of stored graphics images that have information tied to the icon, and then sending this information-rich graphic as a response to the inquiry or inquiries. Advertisers can utilize this capability to send immediately requested information in response to an icon, and have a universally recognized pictorial to lead the user to the information. For example, such pictorial information could include a map, if there is enough resolution in the display, indicating how to reach a location, as well as icons that represent different department phone numbers.

**[0026]** Taking a lead from off-air broadcast commercial television, which is free to the viewer in return for his sitting through commercials, it is contemplated that the geographic-specific advertising capabilities of the invention can be used by phone carriers to obtain advertising-supported revenues to subsidize the charges that they would normally charge their customers. If carriers are allowed to advertise on the handset, they could pass on this revenue in the form of lower charges to the phone user. With this subsidization, more phone customers might be able to use the service if they agree to be exposed to advertising on the network. Such advertising would work as follows. A carrier would act in the manner of a television network, in that it would sell air time for ad space. The highest price would be put on the best spot times. When users have their handsets ON, the empty space on the screen would accept advertising messages. These advertising messages could contain icons and additional information and could be tied to a phone number. Consumers could choose to call the number, or store the number in their handsets for later reference, using an icon. If no immediate action were taken, the advertisement, as on television, would just disappear.

**[0027]** Business to Business Users may also take advantage of the invention by utilizing a graphical representation of a person or business entity, whereby business users can swap electronic business cards. Unlike electronic organizers that require the manual entry and retrieval of phone information, and then the manual dialing of a telephone, the electronic icon addressing application of the invention allows users to exchange business cards by making a phone call using a graphic and affecting the transfer of a business card and its information to another business user. The receiver can store the landline home and business phone number, mobile number, pagers, and e-mail address with related graphical information in the cellular phone. Then, when the second user wants to contact the first user, he scrolls through his address book, and locates the person graphically; he then scrolls through the graphic icons for home, business, mobile, pager, e-mail, etc. and presses SEND upon display of the appropriate icon to contact the first user in the most desired manner and location.

**[0028]** It will be understood that the implementing software for the Interface unit must be written to accommodate its use with a given telephone or cellular network and first must provide the function or capability to tie a graphic to one or more phone numbers.

**[0029]** In addition, the software must allow one user to send his or her graphical information to another user's Graphic electronic phonebook, or location-specific temporary phonebook. The code will be written using graphics as the enabling icon to sort through and retrieve tied information, and these graphics may also be tied to a message and/or more information. The details of producing the software for these purposes and functions in accordance with the invention must depend upon the system and context in which it is to be used and, although it may take various forms, this task will be readily within the skill of the art given the details of the features and functions of the invention as disclosed herein.

**[0030]** It will therefore be seen that the invention enables users, companies, and advertisers to use a phone to exchange graphics that are tied to phone numbers and store the exchanged information in the memory of the phone. Users wishing to make phone calls scroll through the different graphics, logos, or pictures displayed on the phone that define the person or location to be called, and then activate an appropriate graphic, upon seeing the desired icon and pressing a SEND key, to call the person selected.

**[0031]** By adding graphics that can be received over the air to a cellular phone, use of that phone becomes much simpler. Names and numbers tied to the graphics are sent over the air and stored, so that people, places, and entities are easily recalled by the receiving phone's user through graphic recognition. All the necessary information may be sent via a wireless network and stored in the phone's memory. This relieves the user from having to manually enter information that is difficult to recall given the limitation of letters and numbers. This also relieves

the user from having to carry a PDA or computer to generate responses or look up information that can be stored on the cellular phone. Thus, the disclosed use of graphics, which are readily recognized and utilized, renders the operation of telephones, such as cellular phones, extremely user-friendly.

**Claims**

1. A graphic user interface (12) for use with an electronic phonebook (14) in a telephone (10), such as a cellular phone, comprising:

means for tying phone numbers in said phonebook to respective graphic identifiers (13); means for displaying said graphic identifiers on a display screen (11) of said telephone; means for selecting a graphic identifier on said displaying means; and means, responsive to the selecting of a graphic identifier on said displaying means, for activating said telephone to call said respective tied phone number;

**characterised by**

means for storing and tying additional graphical information to said phone numbers in said phonebook along with said respective graphic identifiers; and means, responsive to the completion of a call to said respective tied phone number, for sending said additional graphical information and tied phone numbers to the telephone at said respective tied phone number.

2. An interface as in claim 1 further comprising:

means for scrolling said respective graphic identifiers for successive display on said displaying means.

3. An interface as in claim 1 or 2, wherein said selecting means comprises:

means, coupled to said phonebook, for accessing tied phone numbers therein; SEND means (15) for actuation by a phone user when a respective graphic identifier to be selected is displayed and producing a signal in response to being actuated; and means, coupled to said accessing means and said activating means and responsive to said signal produced by said SEND means, for communicating the phone number tied to said selected respective graphic identifier to said activating means when said SEND means is pressed.

4. An interface as in any preceding claim wherein said tying means comprises:

a database with fields for storing pixel information of said graphic identifiers, and with fields for storing said respective tied phone numbers; and means for accessing both said graphic identifiers and said respective tied phone numbers by the same index into said database.

5. An interface as in any of claims 1 to 4 wherein said tying means comprises a database record holding both a graphic identifier and its respective tied phone number.

6. A telephone comprising:

an electronic phonebook for storing a plurality of phone numbers tied to respective graphic identifiers and additional information tied to said respective graphic identifiers; a display screen for displaying said graphic identifiers; means for producing a scroll signal for scrolling said graphic identifiers on said display screen; and interface means for controlling the providing of said graphic identifiers from said phonebook to said display screen in response to said scroll signal produced by said scrolling means, said interface means comprising an interface according to any preceding claim, wherein:

said means for activating said telephone to call said respective tied phone number further comprises means for sensing when a call has been completed and sending a connect signal, indicating a phone is available for receiving at the phone number called, to said interface; and said interface further comprises means, responsive to said connect signal, for sending said additional information tied to said graphic identifier displayed on said display screen to said available phone.

7. A telephone as in claim 6 wherein said activating means comprises a microprocessor.

8. A telephone as in claim 6 or 7 wherein said interface means further comprises means for storing said graphic identifiers.

9. A telephone as in any of claims 6 to 8 wherein said electronic phonebook comprises means for storing said graphic identifiers.

10. A method of using a graphic identifier with an elec-

tronic phonebook in a telephone, such as a cellular phone, to activate a phone call to a tied phone number, comprising:

- tying phone numbers in said phonebook to respective graphic identifiers;  
 displaying said graphic identifiers on a display screen of said cellular phone;  
 selecting a graphic identifier on said display screen; and  
 while the selected graphic identifier is being displayed on said display screen, activating said phone to call said respective tied phone number;
- characterised by**  
 storing and tying additional graphical information to said phone numbers in said phonebook along with said respective graphic identifiers; and  
 in response to the completion of a call to said respective tied phone number, sending said additional graphical information and tied phone numbers to the phone at said respective tied phone number
11. The method of claim 10 wherein said additional graphical information comprises advertising material.
12. The method of claim 10 or 11 wherein said step of selecting comprises:
- actuating a phone element when a respective graphic identifier to be selected is displayed and producing a signal in response to said phone element being actuated;  
 accessing tied phone numbers from said phonebook; and  
 in response to a signal produced by said phone element being actuated, communicating the phone number tied to said selected respective graphic identifier for activating said phone to call said respective tied phone number.
13. The method of any one of claims 10 to 12 wherein said phonebook comprises a database with fields for storing pixel information of said graphic identifiers, and with fields for storing said respective tied phone numbers, and wherein the method comprises accessing both said graphic identifiers and said respective tied phone numbers by the same index into said database.
14. The method of any one of claims 10 to 12 wherein the method comprises said phonebook holding both a graphic identifier and its respective tied phone number in a database record.
15. The method of any one of claims 10 to 14 comprising:

scrolling said respective graphic identifiers for successive display on said display screen.

## 5 Patentansprüche

1. Grafische Benutzerschnittstelle (12) für die Verwendung mit einem elektronischen Telefonbuch (14) in einem Telefon (10) wie zum Beispiel einem Mobiltelefon, umfassend

- Mittel zum Verknüpfen von Telefonnummern in dem Telefonbuch mit jeweiligen grafischen Kennungen (13);
- Mittel zum Anzeigen der grafischen Kennungen auf einem Anzeigeschirm (11) des Telefons;
- Mittel zum Auswählen einer grafischen Kennung auf den Anzeigemitteln; und
- Mittel, die auf das Auswählen einer grafischen Kennung auf den Anzeigemitteln ansprechen, zum Aktivieren des Telefons, um die jeweilige verknüpfte Telefonnummer anzurufen;

## 25 gekennzeichnet durch

- Mittel zum Speichern und Verknüpfen von zusätzlichen grafischen Informationen mit den Telefonnummern in dem Telefonbuch zusammen mit den jeweiligen grafischen Kennungen; und
- Mittel, die auf den Abschluss eines Anrufs an die jeweilige verknüpfte Telefonnummer ansprechen, zum Senden der zusätzlichen grafischen Informationen und verknüpften Telefonnummern an das Telefon bei der jeweiligen verknüpften Telefonnummer.

2. Schnittstelle nach Anspruch 1, weiter umfassend

- Mittel zum Blättern durch die jeweiligen grafischen Kennungen für aufeinander folgende Anzeige auf den Anzeigemitteln.

3. Schnittstelle nach Anspruch 1 oder 2, wobei die Auswahlmittel umfassen

- Mittel, gekoppelt mit dem Telefonbuch, zum Zugreifen auf verknüpfte Telefonnummern darin;
- SENDE-Mittel (15) zum Betätigen durch einen Telefonbenutzer, wenn eine jeweilige auszuwählende grafische Kennung angezeigt wird, und Erzeugen eines Signals in Reaktion darauf, dass sie betätigt werden; und
- Mittel, gekoppelt mit den Zugriffsmitteln und den Aktivierungsmitteln und ansprechend auf das Signal, das von den SENDE-Mitteln erzeugt wird, zum Übermitteln der Telefonnummer, die

- mit der jeweiligen grafischen Kennung verknüpft ist, an die Aktivierungsmittel, wenn die SENDE-Mittel gedrückt werden.
4. Schnittstelle nach irgendeinem der vorhergehenden Ansprüche, wobei das Verknüpfungsmittel umfasst
- eine Datenbank mit Feldern zum Speichern von Bildpunktinformationen der grafischen Kennungen, und mit Feldern zum Speichern der jeweiligen verknüpften Telefonnummern; und
  - Mittel zum Zugreifen auf sowohl die grafischen Kennungen als auch die jeweiligen verknüpften Telefonnummern durch denselben Index in die Datenbank.
5. Schnittstelle nach irgendeinem der Ansprüche 1 bis 4, wobei das Verknüpfungsmittel einen Datenbank-Eintrag umfasst, der sowohl eine grafische Kennung als auch deren jeweilige verknüpfte Telefonnummer beinhaltet.
6. Telefon, umfassend
- ein elektronisches Telefonbuch zum Speichern von mehreren Telefonnummern, die mit jeweiligen grafischen Kennungen verknüpft sind, und von zusätzlichen Informationen, die mit den jeweiligen grafischen Kennungen verknüpft sind;
  - einen Anzeigeschirm zum Anzeigen der grafischen Kennungen;
  - Mittel zum Erzeugen eines Blätter-Signals zum Blättern durch die grafischen Kennungen auf dem Anzeigeschirm; und
  - Schnittstellenmittel zum Steuern der Bereitstellung der grafischen Kennungen von dem Telefonbuch an den Anzeigeschirm in Reaktion darauf, dass das Blätter-Signal von den Blätter-Mitteln erzeugt wird, wobei die Schnittstellenmittel eine Schnittstelle nach irgendeinem vorhergehenden Anspruch umfassen;
- wobei
- das Mittel zum Aktivieren des Telefons, um die jeweilige verknüpfte Telefonnummer anzurufen, weiter Mittel umfasst, um zu erfassen, wenn ein Anruf abgeschlossen wurde und zum Senden eines Verbindungs-Signals, das angibt, dass ein Telefon zum Empfangen an der angerufenen Telefonnummer verfügbar ist, an die Schnittstelle; und
  - die Schnittstelle weiter Mittel umfasst, die auf das Verbindungs-Signal ansprechen, zum Senden der zusätzlichen Informationen, die mit der grafischen Kennung, die auf dem Anzeigeschirm angezeigt wird, verknüpft sind, an das verfügbare Telefon.
7. Telefon nach Anspruch 6, wobei das Aktivierungsmittel einen Mikroprozessor umfasst.
8. Telefon nach Anspruch 6 oder 7, wobei das Schnittstellenmittel weiter Mittel zum Speichern der grafischen Kennungen umfasst.
9. Telefon nach irgendeinem der Ansprüche 6 bis 8, wobei das elektronische Telefonbuch Mittel zum Speichern der grafischen Kennungen umfasst.
10. Verfahren zum Verwenden einer grafischen Kennung mit einem elektronischen Telefonbuch in einem Telefon wie zum Beispiel einem Mobiltelefon, um einen Anruf an eine verknüpfte Nummer zu aktivieren, umfassend
- Verknüpfen von Telefonnummern in dem Telefonbuch mit jeweiligen grafischen Kennungen;
  - Anzeigen der grafischen Kennungen auf einem Anzeigeschirm des Mobiltelefons;
  - Auswählen einer grafischen Kennung auf dem Anzeigeschirm; und
  - Aktivieren des Telefons, um die jeweilige verknüpfte Telefonnummer anzurufen, während die ausgewählte grafische Kennung auf dem Anzeigeschirm angezeigt wird;
- gekennzeichnet durch**
- Speichern und Verknüpfen von zusätzlichen grafischen Informationen mit den Telefonnummern in dem Telefonbuch zusammen mit den jeweiligen grafischen Kennungen; und
  - Senden, in Reaktion auf den Abschluss eines Anrufs an die jeweilige verknüpfte Telefonnummer, der zusätzlichen grafischen Informationen und verknüpften Telefonnummern an das Telefon bei der jeweiligen verknüpften Telefonnummer.
11. Verfahren nach Anspruch 10, wobei die zusätzlichen grafischen Informationen Werbematerial umfassen.
12. Verfahren nach Anspruch 10 oder 11, wobei der Schritt des Auswählens umfasst
- Betätigen eines Telefonelements, wenn eine jeweilige auszuwählende grafische Kennung angezeigt wird, und Erzeugen eines Signals in Reaktion darauf, dass das Telefonelement betätigt wird;
  - Zugreifen auf verknüpfte Telefonnummern aus dem Telefonbuch; und
  - Übermitteln, in Reaktion auf ein Signal, das von dem betätigten Telefonelement erzeugt wird, der Telefonnummer, die mit der ausgewählten jeweiligen grafischen Kennung ver-

- knüpft ist, zum Aktivieren des Telefons, um die jeweilige verknüpfte Telefonnummer anzurufen.
13. Verfahren nach irgendeinem der Ansprüche 10 bis 12, wobei das Telefonbuch eine Datenbank umfasst, mit Feldern zum Speichern von Bildpunktinformationen der grafischen Kennungen, und mit Feldern zum Speichern der jeweiligen verknüpften Telefonnummern, und wobei das Verfahren umfasst, sowohl auf die grafischen Kennungen als auch die jeweiligen verknüpften Telefonnummern durch denselben Index in die Datenbank zuzugreifen.
14. Verfahren nach irgendeinem der Ansprüche 10 bis 12, wobei das Verfahren umfasst, dass das Telefonbuch sowohl eine grafische Kennung als auch deren jeweilige verknüpfte Telefonnummer in einem Datenbank-Eintrag beinhaltet.
15. Verfahren nach irgendeinem der Ansprüche 10 bis 14, umfassend
- Blättern durch die jeweiligen grafischen Kennungen für die aufeinanderfolgende Anzeige auf dem Anzeigeschirm.
- Revendications**
1. Interface utilisateur graphique (12) à utiliser avec un répertoire téléphonique électronique (14) dans un téléphone (10), tel qu'un téléphone mobile, comprenant :
- des moyens pour attribuer des numéros de téléphone dans ledit répertoire téléphonique à des identifiants graphiques (13) respectifs;
  - des moyens pour afficher lesdits identifiants graphiques sur un écran d'affichage (11) dudit téléphone ;
  - des moyens pour sélectionner un identifiant graphique sur lesdits moyens d'affichage ; et
  - des moyens, réactifs à la sélection d'un identifiant graphique sur lesdits moyens d'affichage, pour activer ledit téléphone pour appeler ledit numéro de téléphone attribué respectif ;
- caractérisée par**
- des moyens pour stocker et attribuer des informations graphiques supplémentaires aux dits numéros de téléphone dans ledit répertoire téléphonique avec lesdits identifiants graphiques respectifs ; et
  - des moyens, réactifs à la fin d'un appel vers ledit numéro de téléphone attribué respectif, pour envoyer lesdites informations graphiques supplémentaires et lesdits numéros de téléphone attribués au téléphone, au dit numéro de téléphone attribué respectif.
2. Interface selon la revendication 1, comprenant également :
- des moyens pour faire défiler lesdits identifiants graphiques respectifs pour un affichage successif sur lesdits moyens d'affichage.
3. Interface selon la revendication 1 ou 2, dans laquelle lesdits moyens de sélection comprennent :
- des moyens, couplés au dit répertoire téléphonique, pour accéder aux numéros de téléphone attribués qu'il contient ;
  - des moyens d'ENVOI (15) à actionner par un utilisateur de téléphone lorsqu'un identifiant graphique respectif à sélectionner est affiché, et produisant un signal en réponse au fait d'être actionnés ; et
  - des moyens, couplés aux dits moyens d'accès et aux dits moyens d'activation, et réactifs au dit signal produit par lesdits moyens d'ENVOI, pour communiquer le numéro de téléphone attribué au dit identifiant graphique respectif sélectionné, aux dits moyens d'activation lorsque l'on presse lesdits moyens d'ENVOI.
4. Interface selon l'une quelconque des revendications précédentes, dans laquelle lesdits moyens d'attribution comprennent :
- une base de données comprenant des champs pour stocker des informations relatives aux pixels desdits identifiants graphiques, et des champs pour stocker lesdits numéros de téléphone attribués respectifs ; et
  - des moyens pour accéder à la fois aux dits identifiants graphiques et aux dits numéros de téléphone attribués respectifs par le même index dans ladite base de données.
5. Interface selon l'une quelconque des revendications 1 à 4, dans laquelle lesdits moyens d'attribution comprennent un enregistrement de la base de données contenant à la fois un identifiant graphique et son numéro de téléphone attribué respectif.
6. Téléphone comprenant :
- un répertoire téléphonique électronique pour stocker une pluralité de numéros de téléphone attribués à des identifiants graphiques respectifs et des informations supplémentaires attribuées aux dits identifiants graphiques respectifs ;
  - un écran d'affichage pour afficher lesdits identifiants graphiques ;
  - des moyens pour produire un signal de défilement pour faire défiler lesdits identifiants graphi-

- ques sur ledit écran d'affichage ; et des moyens d'interface pour contrôler l'approvisionnement desdits identifiants graphiques dudit répertoire téléphonique vers ledit écran d'affichage en réponse au dit signal de défilement produit par lesdits moyens de défilement, lesdits moyens d'interface comprenant une interface selon l'une quelconque des revendications précédentes, dans lequel :
- lesdits moyens pour activer ledit téléphone pour appeler ledit numéro de téléphone attribué respectif comprennent également des moyens pour détecter quand un appel est terminé et pour envoyer un signal de connexion, indiquant qu'un téléphone est disponible pour recevoir au numéro de téléphone appelé, à ladite interface ; et ladite interface comprend également des moyens, réactifs au dit signal de connexion, pour envoyer lesdites informations supplémentaires attribuées au dit identifiant graphique affiché sur ledit écran d'affichage au dit téléphone disponible.
7. Téléphone selon la revendication 6, dans lequel lesdits moyens d'activation comprennent un microprocesseur.
8. Téléphone selon la revendication 6 ou 7, dans lequel lesdits moyens d'interface comprennent également des moyens pour stocker lesdits identifiants graphiques.
9. Téléphone selon l'une quelconque des revendications 6 à 8, dans lequel ledit répertoire téléphonique électronique comprend des moyens pour stocker lesdits identifiants graphiques.
10. Procédé d'utilisation d'un identifiant graphique avec un répertoire téléphonique électronique dans un téléphone, tel qu'un téléphone mobile, pour activer un appel téléphonique vers un numéro de téléphone attribué, comprenant les étapes consistant à :
- attribuer des numéros de téléphone dans ledit répertoire téléphonique à des identifiants graphiques respectifs ; afficher lesdits identifiants graphiques sur un écran d'affichage dudit téléphone mobile ; sélectionner un identifiant graphique sur ledit écran d'affichage ; et tandis que l'identifiant graphique sélectionné est affiché sur ledit écran d'affichage, activer ledit téléphone pour appeler ledit numéro de téléphone attribué respectif ;
- caractérisé par** les étapes consistant à :

- stocker et attribuer des informations graphiques supplémentaires aux dits numéros de téléphone dans ledit répertoire téléphonique avec lesdits identifiants graphiques respectifs ; et en réponse à la fin d'un appel vers ledit numéro de téléphone attribué respectif, envoyer lesdites informations graphiques supplémentaires et lesdits numéros de téléphone attribués au téléphone, au dit numéro de téléphone attribué respectif.
11. Procédé selon la revendication 10, dans lequel lesdites informations graphiques supplémentaires comprennent du matériel publicitaire.
12. Procédé selon la revendication 10 ou 11, dans lequel ladite étape de sélection comprend les étapes consistant à :
- actionner un élément de téléphone quand un identifiant graphique respectif à sélectionner est affiché et produire un signal en réponse au fait que le dit élément de téléphone est actionné ; accéder à des numéros de téléphone attribués à partir dudit répertoire téléphonique ; et en réponse à un signal produit lorsque ledit élément de téléphone est actionné, communiquer le numéro de téléphone attribué au dit identifiant graphique respectif sélectionné pour activer ledit téléphone pour appeler ledit numéro de téléphone attribué respectif.
13. Procédé selon l'une quelconque des revendications 10 à 12, dans lequel ledit répertoire téléphonique comprend une base de données comprenant des champs pour stocker des informations relatives aux pixels desdits identifiants graphiques, et des champs pour stocker lesdits numéros de téléphone attribués respectifs, et dans lequel le procédé comprend l'accès à la fois aux dits identifiants graphiques et aux dits numéros de téléphone attribués respectifs par le même index dans ladite base de données.
14. Procédé selon l'une quelconque des revendications 10 à 12, dans lequel procédé ledit répertoire téléphonique contient à la fois un identifiant graphique et son numéro de téléphone attribué respectif dans un enregistrement de la base de données.
15. Procédé selon l'une quelconque des revendications 10 à 14 comprenant :
- le défilement desdits identifiants graphiques pour un affichage successif sur ledit écran d'affichage.



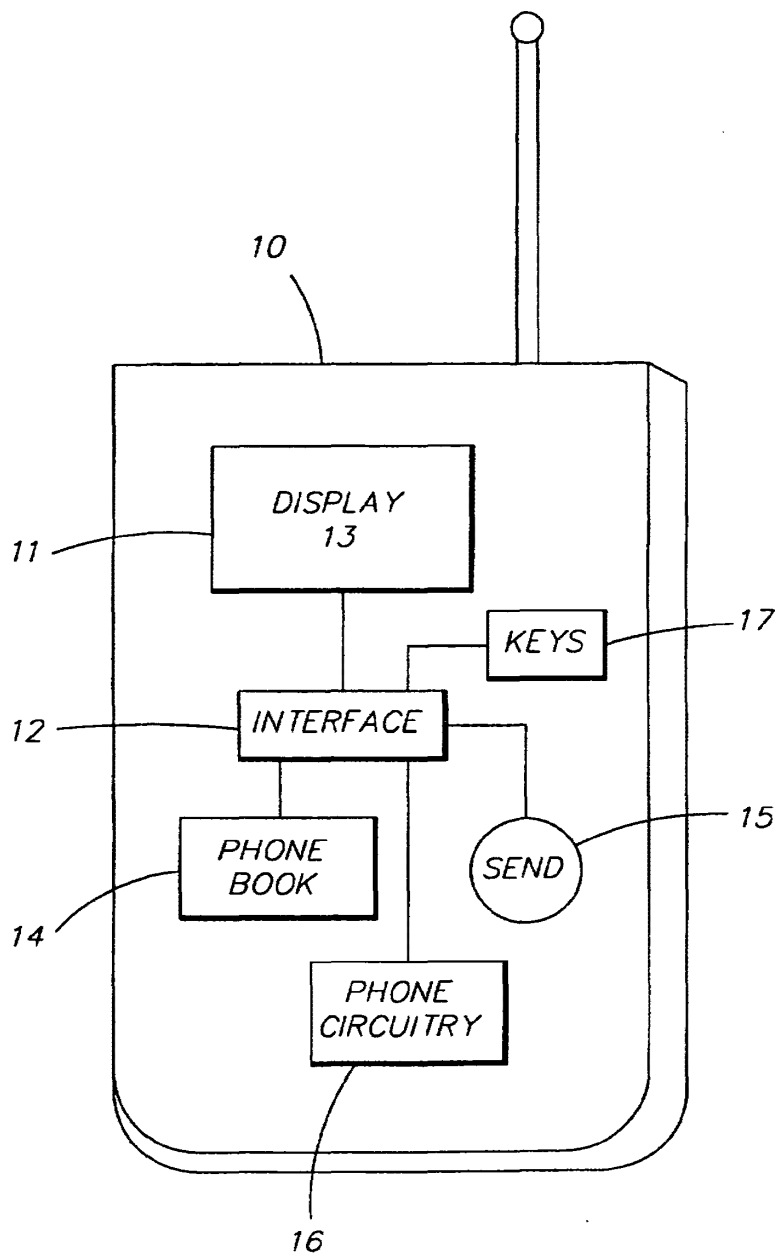


FIG. 1

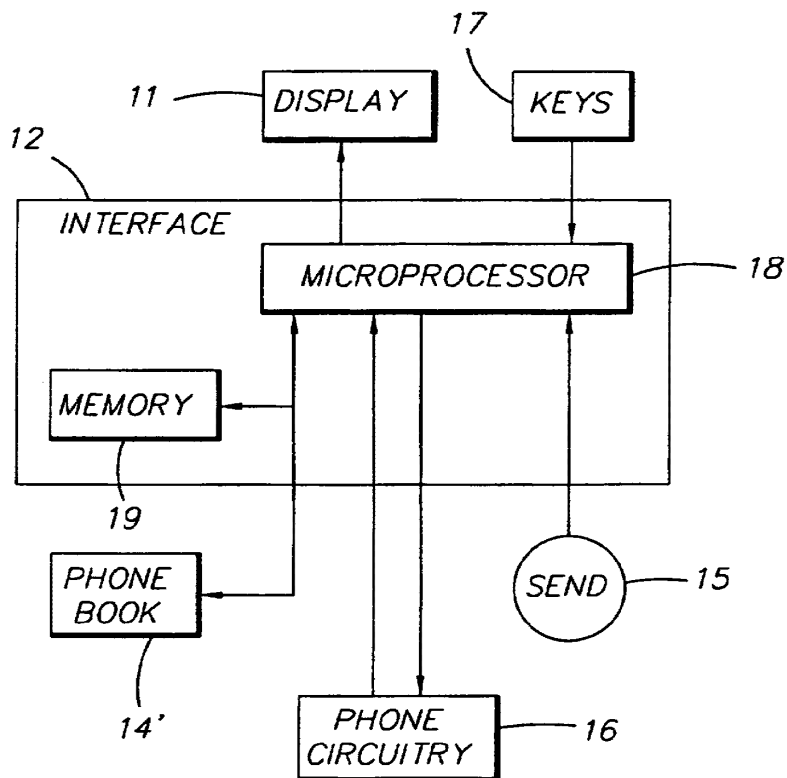


FIG. 2

**EP 0 858 202 B1**

**REFERENCES CITED IN THE DESCRIPTION**

*This list of references cited by the applicant is for the reader's convenience only. It does not form part of the European patent document. Even though great care has been taken in compiling the references, errors or omissions cannot be excluded and the EPO disclaims all liability in this regard.*

**Patent documents cited in the description**

- EP 0493084 A [0005]
- US 5778054 A [0006]



(11) **EP 0 869 688 B1**

(12) **EUROPEAN PATENT SPECIFICATION**

(45) Date of publication and mention of the grant of the patent:  
**28.02.2007 Bulletin 2007/09**

(51) Int Cl.:  
**H04Q 3/00<sup>(2006.01)</sup> H04M 3/42<sup>(2006.01)</sup>**  
**H04Q 7/22<sup>(2006.01)</sup>**

(21) Application number: **98660027.8**

(22) Date of filing: **30.03.1998**

(54) **A method and means for transmitting a service page in a communication system**

Verfahren und Vorrichtung zum Übertragen einer Dienstseite in einem Kommunikationssystem

Procédé et dispositif de transmission d'une page de service dans un système de communication

(84) Designated Contracting States:  
**DE FR GB SE**

(30) Priority: **04.04.1997 FI 971386**

(43) Date of publication of application:  
**07.10.1998 Bulletin 1998/41**

(73) Proprietor: **Nokia Corporation**  
**02150 Espoo (FI)**

(72) Inventors:  
• **Kari, Janne**  
**00670 Helsinki (FI)**

• **Rautila, Heikki**  
**02130 Espoo (FI)**

(74) Representative: **Brax, Matti Juhani et al**  
**Berggren Oy Ab,**  
**P.O. Box 16**  
**00101 Helsinki (FI)**

(56) References cited:  
**EP-A- 0 590 862** **US-A- 5 485 511**

**EP 0 869 688 B1**

Note: Within nine months from the publication of the mention of the grant of the European patent, any person may give notice to the European Patent Office of opposition to the European patent granted. Notice of opposition shall be filed in a written reasoned statement. It shall not be deemed to have been filed until the opposition fee has been paid. (Art. 99(1) European Patent Convention).

**Description**

- 5 [0001] The present invention relates to a method and means for transmitting service pages implemented in a telecommunication network, such as in an Internet network, to a terminal. The invention is suitable for use particularly in connection with portable terminals, such as mobile stations.
- 10 [0002] Digital telephone exchanges and terminals, such as telephones of a wired network and mobile stations, provide for a number of new services to be utilised. One of them is the commonly used identification service of a caller (subscriber A), i.e., the CLIP (Calling Line Identification Presentation) service. With the help of this service, the identifier of the subscriber A, substantially the telephone number of the subscriber A, is transmitted to a receiving terminal (subscriber B), wherein it is typically displayed on the display of the terminal of the subscriber B. On the basis of this information, the subscriber B can see from which number the call is coming. It is also very common that the most frequently used telephone numbers and the names and other identifiers of the corresponding persons have been stored in the terminal of the subscriber B. This function is used particularly in mobile telephones, wherein it is possible to display, on the display of the terminal of the subscriber B, the name or some other identifier of the subscriber A, e.g., the name of the subscriber A's company, on the basis of the telephone number of the subscriber A. Another new service provided by digital telephone networks is the so-called CoLP (Connected Line Identification Presentation) service. This service transmits to the caller (subscriber A) information on what is the actual identifier (telephone number) of the opposite end (subscriber B) of the connected line. With the help of this service, the subscriber A receives information on the subscriber B's actual telephone number of that moment even if the subscriber B has carried out a call transfer.
- 20 [0003] The supplementary services relating to the identification of a line, such as the CLIP and CoLP services presented above, defined in the GSM mobile telephone system, have been presented in the GSM Standard GSM 02.81 of the ETSI (European Telecommunications Standards Institute). It defines, amongst other things, in which form the CLIP and CoLP data are transmitted in the GSM system. Both the CLIP and CoLP services contain an extremely limited amount of information. It would be useful if, in addition to the CLIP and CoLP services, it would also be possible to transmit other information.
- 25 [0004] European patent application (0 590 862 A2) discloses a method for providing information for display at a calling party telecommunication station or at an idle station. An ISDN display unit is used to display information received over a D-channel of an ISDN signal connecting an ISDN telephone to a switch, whether or not the ISDN station is calling or being called or is idle.
- 30 [0005] An increasing number of companies and corporations, in particular, but also private persons have taken into use services based on the Internet network. Due to advanced terminals and more efficient network connections, it is possible to transmit, in the Internet network, various kinds of data including speech and video pictures. Hypermedia pages that have been implemented in the HTML (Hypertext Markup Language) in a WWW (World Wide Web) environment have become particularly popular. On these hypermedia pages, it is possible to create interactive documents or purely informative service pages. Similarly, the pages can also be used for advertising or for providing the address or personal data of a company or a private person possibly together with maps and pictures.
- 35 [0006] The Internet network consists of a number of servers and telecommunication networks, which transmit messages in a digital form. The messages, such as, e.g., hypermedia pages, are transferred as files from one server to another and finally to a receiving terminal. The HTTP (HyperText Transfer Protocol) is commonly used for data transmission, the protocol transmitting the information intended for transfer in a form of a packet between the terminals on the basis of a URL (Uniform Resource Locator) address information characteristic of each terminal.
- 40 [0007] A method and means have now been invented by means of which it is possible to utilise service pages provided by a telecommunication network, e.g., the Internet network, by means of wired or wireless terminals coupled to the telecommunication network, on the basis of supplementary services, such as the CLIP and CoLP services presented above, relating to line identification. The service pages may contain, e.g., text, graphics or moving video pictures. In a communication system according to the present invention, it is possible to transmit service pages according to several principles. In a first embodiment, a caller (subscriber A) can link the address of the desired service page (in the Internet network, a URL identifier) with the subscriber's own identifier (in the GSM system, with the information transmitted by the CLIP service, i.e., one's own telephone number), on the basis of which a receiving terminal (subscriber B) can retrieve the selected service page from the telecommunication network and display it on the display of the receiving terminal. This method can be utilised, e.g., for advertising purposes, whereupon a teleseller transmits additional information to the customers called. In a second embodiment of the present invention, a receiving terminal (subscriber B) links, on the basis of the telephone number of a subscriber A, the service page he has selected with the number in question and retrieves the service page to his own display. This proceeding is suitable, e.g., for a seller (subscriber B) receiving calls for presenting customer data, whereupon he can, on the basis of the caller's CLIP information, retrieve from his own or the company's database the caller's (subscriber A) volume of orders in hand, prices or even credit information.
- 55 [0008] The chapter above presented different embodiments of the present invention, wherein the desired service page was retrieved from the subscriber A on to the display of the subscriber B on the basis of the CLIP service transmitted

to the subscriber B. Similarly, the desired service page can be transmitted on the basis of a CoLP service. In a third embodiment of the present invention, a service page selected by the subscriber B, which can be used, e.g., for advertising purposes, is transmitted on to the display of the subscriber A. This embodiment is suitable, e.g., for situations, where a customer calls the telephone number of a company providing certain products or services and receives automatically to his terminal additional information on the products or services provided by the company in the form of a service page. However, the use of the CoLP service instead of the CLIP service gives one advantage. The subscriber A, at whom the advertisement is directed, can be certain of the advertisement's origin because, for example, call transfers implemented in a telephone network cannot affect the authenticity of the CoLP service. This method is also extremely suitable for key telephone systems, wherein it is possible to implement, e.g., in a hospital on duty, a service which automatically tells the subscriber A the contact information, rank and, for example, the special expertise of the person who has answered the key telephone. On the basis of this information, the customer knows to whom he is speaking and can ask the call to be transferred to another person if necessary.

**[0009]** In a fourth embodiment of the present invention, a service page that he himself has selected is transmitted to the subscriber A on the basis of the CoLP service. This enables, for example, the expansion of the teleselling application presented in the second embodiment of the present invention so that the customer's volume of orders in hand, prices or even credit information, stored in the company's database, are also automatically available when a seller acts as the subscriber A, i.e., calls the customers (subscribers B). This system is safe, because the reliability of the CoLP information guarantees that the seller can be certain with whom he is doing business. However, nothing prevents the seller application presented above from being further expanded so that said service page is transmitted to both the seller and the customer, whereupon they can refer to the same database during the discussion. In this case, however, safety factors (e.g., to prevent credit information and/or other information intended for the company's internal use from being transmitted) should be taken into consideration.

**[0010]** In the embodiments of the present invention presented above, a reference table, typical of the invention, is required, wherefrom a URL address of the desired service page is retrieved on the basis of the information transmitted by the CLIP or CoLP service. The reference table can be located in different servers of a telecommunication network (e.g., the Internet), in servers implemented in connection with a telephone exchange or a private branch exchange, in a company's own data network (e.g., intranet) or in a user's own computer. It is also possible to store the reference table, e.g., in the memory of a portable terminal, such as a communicator like the Nokia 9000 Communicator. In this case, the transmission of the service page speeds up, because it is not necessary to retrieve the URL address of the service page from the server implemented in connection with the telecommunication network or the telephone exchange, but the communicator can download the desired service page directly from the URL address it has retrieved from its memory.

**[0011]** Thus, the transmission of a service page in a communication system according to the present invention enables, amongst other things, an Internet home page, characteristic of each individual or company, to be displayed on the display of the terminal of the subscriber B instead of the telephone number or the name of the subscriber A. Hence, the present invention provides versatile and flexible opportunities to increase the amount of information transmitted on the basis of the CLIP and CoLP services and lays a foundation for providing new types of information services. The invention is suitable for use in connection with both terminals coupled to a wired network and portable terminals, such as mobile stations.

**[0012]** The invention is characterized by what is set forth in the independent claims. Preferred embodiments of the invention are described in the dependent claims.

Figure 1 illustrates an example of a telecommunication system according to the invention and its structural parts,

Figure 2 illustrates, as a flowchart, the transmission of a service page, according to the invention, in an embodiment of the invention, wherein a subscriber B selects the desired service page,

Figure 3 illustrates how address information and identification information are included in a data packet,

Figure 4 illustrates an implementation of the implementation of a reference table, characteristic of the invention,

Figure 5 illustrates a data packet used for transmitting information in connection with the invention, and the information it contains,

Figure 6 illustrates an example of a service page that can be transmitted in a manner according to the invention,

Figures 7, 8 and 9 illustrate, as a block diagram, the transmission of a service page according to the invention in certain embodiments of the invention, and

Figure 10 illustrates a communicator according to the invention and its structural parts.

5

**[0013]** Figure 1 illustrates an example of a telecommunication system according to the present invention, wherein it is possible to transmit service pages, created and maintained in a telecommunication network, on to the display of terminals. The system comprises different kinds of terminals, such as mobile stations 10 and 11 that can be coupled to computers 20 and 21, traditional mobile stations 12, communicators 13, wired telephones 14 that can be coupled to a computer 22, as well as ordinary telephones 15. In addition to these, an extremely suitable terminal is a computer which is equipped, e.g., with a radio module, connected to the computer's PCMCIA (Personal Computer Memory Card International Association) bus, the radio module providing for a wireless communication connection to be established in telecommunication networks. Area 18, indicated by a dashed line, illustrates a telecommunication system within an office. In addition to the mobile stations 10 and 11, coupled to the computers 20 and 21, it comprises a local area network (LAN, Reference 26), as well as a server 23. The local area network 26 has been coupled to public telecommunication networks, such as an Internet network 120 by means of a router 27. Public Internet servers 24 are connected to the Internet network 120. The Internet network 120 is in contact with a public telephone network (ISDN/PSTN, Reference 110) through a gateway server 25. From the gateway server 25, there is also a connection to a mobile services switching centre 100. Base station controllers 104 and base stations 105, known to a person skilled in the art, as well as other structural parts characteristic of a mobile network are in contact with the mobile services switching centre. In connection with the mobile services switching centre, there is also provided a separate database 101 for storing CLIP OR CoLP identifiers 53 and the corresponding URL addresses 54.

10

15

20

25

30

**[0014]** In the following, the transmission of a service page according to the present invention is described in detail with the help of a preferred example, wherein a receiving terminal retrieves through the Internet network, on the basis of the information transmitted by means of a CLIP service, additional information on a caller (subscriber A) and displays it on the display of a receiving terminal (subscriber B). If no additional information is available, the receiving terminal displays on its display the mere information transmitted by the CLIP service (i.e., the caller's telephone number) in a manner known to a person skilled in the art. In this example, the traditional mobile station 12 acts as the caller (subscriber A) and the telephone 14, which is in contact with the computer 22 and the telephone network 110, is the receiving terminal. Figure 2 illustrates, in the form of a block diagram, the procedure that has been presented in detail both above and in the following chapter.

**[0015]** When a call is made from the mobile station 12 (subscriber A 12), through the base station 105, the base station controller 104, the mobile services switching centre 100 and the telephone network 110, to the subscriber number (Phase 30, Figure 2) of the telephone 14 (subscriber B 14), the subscriber number (telephone number) of the mobile station 12 is transmitted as a CLIP service to the telephone 14 (Phase 31) in manner known to a person skilled in the art. If the telephone 14 is, e.g., an ISDN telephone equipped with a display, the telephone number of the mobile station 12 is normally displayed on a display 16 of the telephone 14. The communication system according to the invention preferably also provides an opportunity to present other information. In this embodiment of the invention, this is implemented so that the computer 22 has been coupled, by means of a cable 28, parallel to the telephone 14 and from the computer there is a connection to the Internet network 120. When the CLIP information arrives at the telephone 14, it is also simultaneously transmitted, through the cable 28, to the computer 22, e.g., through a commercially available ISDN card installed in the computer 22. The ISDN card, installed in the computer 22, identifies the subscriber identifier (telephone number) of the subscriber A 12 and stores it in its memory, where to an application program, installed in the computer 22, can go and read it, e.g., through the computer's PCI (Peripheral Component Interconnect) or ISA (Industry Standard Architecture) bus. Alternatively, the ISDN card can transmit the subscriber identifier directly into the computer's memory through said buses and inform the application program by means of a message informing of the reception of the CLIP information. The application program can be implemented in a manner known to a person skilled in the art by utilising an application programming interface (API) supplied by the ISDN card manufacturer. The implementation of the application program is dependent on the structure of the ISDN cards and on the implementation of the different kinds of application programming interfaces provided by the card manufacturers. After having received the CLIP identifier of the subscriber A 12, the computer 22 contacts, through the Internet network 120, a reference server (Phase 32), in this case, e.g., the address server 24, by transmitting it a contact message 40 (Figure 3).

35

40

45

50

55

**[0016]** In the contact message 40 (Figure 3), the computer 22 includes, in addition to a URL (Uniform Resource Locator) address 41 of the address server 24, a CLIP identifier 42 of the subscriber A, which is thus transmitted to the address server 24 (Phase 33). The address server 24 comprises a reference database 50 (Figure 4), wherein a number of Internet addresses (URL1-URLN, Reference 54) corresponding to the CLIP identifiers (CLIP1-CLIPN, Reference 53) of different subscribers have been stored. This reference database 50 can be maintained, e.g., by some commercial service provider in contact with the telecommunication network 120, but the reference database can also be integrated

with the mobile services switching centre 100 and/or the database 101 arranged in connection with it. When the address server 24 receives the contact message 40 from the computer 22, it goes to its reference database 50 to see whether the CLIP identifier 53, corresponding to the CLIP identifier 42 of the subscriber A in question, can be located (Phase 34). If the corresponding CLIP identifier 53 cannot be located in the reference database 50, then neither has the corresponding URL address 54 been linked with the CLIP identifier 42 in question. In that case, the address server 24 transmits to the computer 22 a response message 60 (Figure 5), wherein it informs that the URL address 54 corresponding to the CLIP identifier 42 cannot be located. The response message 60 comprises a URL address 61 of the computer 22 on the basis of which the response message 60 is routed to the computer 22, as well as the CLIP identifier 42 of the subscriber A, a URL data field 63 and an additional data field 64. The CLIP identifier 42 of the subscriber A is placed in the response message 60 so that the computer 22 is able to distinguish between the possibly many response messages 60, relating to different calls. A negative search result is indicated, e.g., so that the URL data field 63 of the response message 60 is left empty. If the URL address 54 corresponding to the CLIP identifier 42 of the subscriber A was not located, the computer 22 displays on its display, if so required, a text which informs that no URL address (i.e., an Internet address, wherefrom the service page could be retrieved) corresponding to the caller (subscriber A 12) can be located (Phase 35). If the telephone 14 is equipped with the sufficiently large display 16, it is possible to transmit the information directly on to the display 16 of the telephone 14. After the optional message mentioned above (Phase 35), the CLIP identifier (telephone number) of the subscriber A is displayed as normal on the display 16 of the telephone 14 (Phase 36).

**[0017]** If a CLIP1 identifier 51, corresponding to the caller's CLIP identifier 42, is located in the reference database 50, the address server 24 places a URL1 address 52 corresponding to it in the URL data field 63 of the response message 60. After this, the address server 24 sends the response message 60 to the computer 22 (Phase 37). After having received the response message 60, the computer 22 retrieves on the basis of the URL address 63, through the Internet network 120, a service page 70 corresponding to the URL address 63 (Figure 6) from one of the servers 23, 24, 25 (Phase 38) connected to the network. The server can be the same as the reference server 24, but it can just as well be the subscriber A's own server located anywhere in the Internet network 120. The server 23, 24, 25 can also be a commercial service that can be purchased from teleoperators, whereupon the server is typically on the teleoperators' premises. After having retrieved the service page (e.g., the information page 70 implemented in the HTML page description language), the subscriber B 14 preferably displays it on the high-quality display of the computer 22 (Phase 39), but depending on the properties of the display 16 of the telephone 14, it can also be displayed on the display 16 instead of the telephone number (CLIP identifier 42). In this exemplary case, the service page 70 contains, among other things, address information 71 of the subscriber A 12, a greeting 72 and a picture 73 of the user of the telephone 12. In addition, the service page 70 may comprise, e.g., links 74 to other WWW pages, as well as audio and video shots. Since separate communication connections are used for switching the call and transmitting the service page 70 (telephone network 110 and Internet network 120), the transmission of the service page according to the present invention does not affect normal call set-up at all. The time consumed on transmitting the service page 70 from the server 23, 24, 25 that is in contact with the Internet network 120, depends only on the capacity of the Internet network 120 and different components 23, 24, 25, 26, 27 that are in contact with it.

**[0018]** The area 18, indicated by a dashed line in Figure 1, illustrates a communication system used within an office. The local area network 26 is used as its internal communication bus. The architecture of this system differs from the one presented above in that the computers 20 and 21 are equipped with the specified mobile stations 10 and 11 to be connected to the computers. The mobile stations 10 and 11 are equipped with means which also enable calls to be transmitted through the Internet network 120. Thus, no separate direct connection to the telephone network 110 is preferably required. The usefulness of transmitting the service page 70 by means of the identification services (e.g., the CLIP and CoLP services) of a line according to the present invention is illustrated below by way of another example, wherein said office is assumed to be a teleselling office. A common database for all the telesellers comprising, among other things, the customers' contact information, volume of orders in hand, invoicing and information on previous contacts has been stored in the company's own server 23. Communication from the computers 20 and 21 to the server 23 is managed using Internet protocol and the local area network 26, but since external servers (e.g., the computer 22) have limited access to the database mentioned above, the system is called an Intranet network.

**[0019]** When the mobile station 10, 11 is coupled to the computer 20, 21, the computer 20, 21 identifies the mobile station 10, 11 coupled thereto, e.g., on the basis of a telephone number stored in a SIM (Subscriber Identity Module) card used in the mobile station. After this, the computer 20, 21 sends, through the local area network 26, the router 27 and the Internet network 120, the information about the coupling to the server 25. The server 25 maintains a database of those mobile stations which are connected to the computers 20 and 21 and sends the information further to the mobile services switching centre 100 or correspondingly to the telephone exchange 110, e.g., as a call transfer. Thus, the mobile services switching centre 100, the telephone exchange 110 and the server 25 can route the incoming calls through the Internet network 120 to the mobile stations 10, 11 coupled to the computers 20, 21. When the mobile station 10, 11 is connected to the computer 20, 21, the traditional radio frequency components of the mobile station 10, 11 can be switched off. The mobile station 10, 11 operates unconnected, i.e., when it has not been coupled to the terminal 20, 21, just as



the ordinary mobile station 12.

**[0020]** When the subscriber A, e.g., the mobile station 12, contacts the subscriber B, i.e., the mobile station 10 in this teleselling example, the CLIP information is transmitted from the mobile station 12 to the mobile station 10 through the mobile services switching centre 100, the server 25, the Internet network 120, the router 27, the local area network 26 and the computer 20. When perceiving the CLIP information 42 transmitted to the mobile station 10, a program installed in the computer 20 establishes a connection, through the local area network 26, to the office's own server 23 and retrieves therefrom the service page corresponding to the subscriber A 12 (containing the subscriber A's address information etc. as presented above), provided that it can be located in the file. In this respect, the activity corresponds to the principle described in connection with the embodiment presented above. Thus, the information retrieval procedure, implemented in this teleselling example on the basis of a CLIP identifier according to the present invention, provides for the customer data of a customer contacting by telephone to be updated on the screen of the computer 20 preferably without the user of the computer 20 being actively involved. The communication system according to the invention facilitates and speeds up the work of telesellers because, in the previous systems, it has been necessary to separately retrieve customer data from a database manually, e.g., on the basis of the caller's name.

**[0021]** In the two exemplary cases, presented above in detail, a wired communication connection was used to retrieve a service page from the Internet network 120 or from an intranet network (local area network 26). Advanced telecommunication terminals also provide an opportunity to utilise wirelessly the transmission of the service page 70, according to the present invention, on the basis of a CLIP or CoLP identifier. In the following, the present invention will be illustrated by way of example, wherein a telephone 15 is the subscriber A and the communicator 13 is the subscriber B. When a connection is established from the telephone 15 to the communicator 13 through the telephone network 110, the mobile services switching centre 100, the base station controller 104 and the base station 105, the CLIP identifier of the telephone 15 is transmitted to the communicator 13 in a known manner. On the basis of this information, the communicator 13 according to the present invention opens up a data connection through the mobile network 105, 104, 100 and the server 25 to the Internet network 120 and further, e.g., to the server 24, wherefrom it retrieves the service page addressed to the subscriber A (telephone 15) provided that it exists. In principle, the procedure is the same as in the two previous embodiments of the invention presented above. The structural parts of the communicator 13 according to the invention, i.e., a processor 131, a memory 132, radio parts 133, an antenna 134, a small display 135 and a keyboard 136 have been illustrated folded in Figure 10. The service page retrieval process is preferably implemented programmably in the processor 131 and the program code itself has been stored in the memory 132.

**[0022]** However, when using the wireless communication connection, presented in the previous chapter, we face a problem in the current mobile communication systems. In the GSM system, for example, there is only one traffic channel for transmitting speech and data. This prevents speech and data from being transmitted simultaneously from two different addresses 15, 24. The reason for this is that the call set up by the subscriber A 15 to the subscriber B 13 requires a traffic channel of its own in the same way as the data connection used for transmitting the service page 70 from the server 24 to the subscriber B 13.

**[0023]** What has been presented above will no longer be a problem in future mobile networks, which will provide for several different types of data to be transmitted simultaneously. An example of this is the GPRS (General Packet Radio Service), to be implemented on the GSM system, which provides a data transmission channel in the form of a packet that can be used at the same time as the normal traffic channel used for speech transmission. Thus, the service page transmission system according to the present invention is extremely suitable for use in connection with GPRS-type mobile networks, wherein normal speech communication is established using a normal GSM traffic channel and the service page is retrieved from the Internet network 120 using a GPRS data channel.

**[0024]** Alternatively, the problem presented above can be solved using a short message service (SMS), provided by the GSM system, for transmitting the service page 70. The short message service is a data channel originally designed for transmitting short messages consisting of a maximum of 160 ASCII characters, although the short message service is expected to be expanded. The expansion of the short message service will also provide for messages consisting of more than 160 characters to be transmitted by dividing the transferable data into several successive short messages. The short messages are transmitted in a signaling channel and, therefore, the use of the short message service does not restrict the use of the traffic channel for simultaneous speech communication.

**[0025]** It is also possible to implement the system for transmitting the service pages 70, according to the present invention, in the existing GSM networks without short messages by using supplementary services (SS) and unstructured supplementary service data (USSD), provided by the GSM system. In addition to the CLIP and CoLP services mentioned above these include, among other things, putting an answered call on hold and setting up a second connection. A prerequisite for the use of the supplementary services is that the terminal has certain intelligence, but preferably no changes have to be made in the mobile network 100, 104, 105. In the following, an embodiment of the present invention is presented in detail by referring to Figure 7. In this embodiment, the communicator 13 retrieves the service page 70 wirelessly utilizing the supplementary services of a GSM network.

**[0026]** In Figure 7, the operation of the embodiment of the invention, mentioned above, has been illustrated in the

form of a flowchart. First, the subscriber A (telephone 15) calls the subscriber B, through the telephone network 110, the mobile services switching centre 100, the base station controller 104 and the base station 105, and the CLIP identifier 42 is transmitted to the subscriber B, i.e., to the communicator 13 (Phase 80). After having received the CLIP identifier, the communicator can retrieve the service page 70 in a number of ways. The CLIP service of the GSM system enables the subscriber A to be identified without the call being answered. Thus, it could be possible for the processor 131 of the communicator 13 to initiate the process of retrieving the service page 70 without answering the call coming from the subscriber A. However, because it is impossible to know the exact time consumed on the transmission of the service page 70, retrieved through the Internet network 120, it is better to answer the call and ask, e.g., by means of a message stored in the memory 132 of the communicator 13, the subscriber A 15 to hold on a moment without disconnecting the telephone 15. Naturally, this information could be transmitted orally, but one advantage of the invention is just the fact that the service page 70 can be transmitted automatically without the subscriber B being actively involved. In the embodiment illustrated in Figure 7, it is assumed that the communicator 13 answers the call automatically, transmits to the subscriber A the message telling to wait, stored in advance in the memory 131, and, after this, sets the call coming from the subscriber 15 on hold (Phase 81). Next, the communicator 13 sets up, through the radio parts 133 and the antenna 134, a data call to the server 24, which is in contact with the Internet network 120, through the mobile network 100, 104, 105 and the server 25 (Phase 82). After this, the server 24 goes through its reference table 50 to see whether the URL address 52, corresponding to the CLIP information 42 of the subscriber A, can be located (Phase 83). If a corresponding URL address cannot be located, the server 24 transmits to the communicator 13 the response message 60 informing of the negative search result. In that case, if so required, the communicator 13 displays on its display 17, e.g., a message "Service Page Unavailable", to the user (Phase 84). In the next phase, the communicator 13 disconnects the data call it has set up (Phase 85) and returns the call coming from the subscriber A 15 that has been put on hold, to an active state (Phase 87). But if the server 24 locates, in its reference database 50, the URL address 52 corresponding to the CLIP information 42 of the subscriber A 15, the server 24 transmits the URL address 52 to the communicator 13 included in the response message 60 informing of the positive search result (Phase 88). On the basis of the URL address 52 it has received, the communicator 13 makes contact, through the open data channel, with the server indicating the URL address 52 (e.g., the server 25 maintained by an operator) (Phase 89) and asks it to transmit the service page 70 corresponding to the subscriber A 15 (Phase 90). When the service page 70 has been received in full, the communicator 13 disconnects the data connection controlled by the processor 131 (Phase 91) and returns the call on hold to an active state (Phase 92). The service page 70, corresponding to the subscriber A, that has been retrieved through the Internet network 120 is displayed on the display 17 of the communicator 13 according to the present invention (Phase 93) instead of a mere telephone number provided by the CLIP service.

**[0027]** If the reference table 50 is located in the memory 132 of the communicator 13, instead of being in a telecommunication network server (such as the server 24 mentioned in the specification of Figure 7), the process presented above is simpler. The reason for this is that it is not necessary to first contact telecommunication network servers in order to find out the URL address of the service page 70 (Phase 82, Figure 7), but the possible URL address can be located directly in the memory 132 of the communicator 13. Thus, it is neither necessary to perform the activities illustrated in the phases 85, 86 and 88 of Figure 7, because the subscriber A is put on hold (Figure 8, Phase 81) only after the URL address has been retrieved from the memory 132 (Phase 94). Figure 8 illustrates this particular embodiment of the present invention. The phases 80, 81, 84, 87, 89, 90, 91, 92 and 93, common to Figures 7 and 8, have been illustrated using the same numbers. It is also possible to equip the memory 132 of the communicator 13 with a combination software enabling the service page 70 to be utilised irrespective of whether the reference table 50 is located in a telecommunication network server or in the actual terminal (communicator 13).

**[0028]** In the examples of the embodiments presented above, the service page 70 was always transmitted from a server chosen by the receiver (subscriber B). It is true that this is a natural course of action according to the nature of the transmission mechanism of CLIP information and that of call traffic, since it is always the receiver who also makes the final decision of whether he answers the incoming call at all. However, it is also possible to transmit the service page 70 on the basis of the CLIP information, according to the present invention, controlled by the subscriber A provided that the subscriber B allows this with his terminal. The practical implementation corresponds to what has been presented in connection with the specification of Figures 2-8 with the exception that the subscriber A has been provided with an opportunity to edit the reference database 50 (Figure 4). Thus, the subscriber A can specify the URL address 52 corresponding to this own CLIP identifier (e.g., CLIP1, Reference 51). Hence, when the subscriber A establishes a connection to the subscriber B, the service page selected by the subscriber A, e.g., a service price-list or some other commercial handout, is transmitted to the subscriber B.

**[0029]** The procedure presented above can also be utilised in connection with automatic telecommunication services. In the following, we will describe, as an exemplary embodiment, the transmission of tips for the pools and the results of ice-hockey matches from the server 25 (subscriber A) to the portable communicator 13 (subscriber B). The service page comprising the tips for the pools and the results of the matches has been implemented, e.g., in the HTML page description language as the service page 70 illustrated in Figure 6. In this example, the user of the communicator 13 has made a

contract with a public telecommunications operator for the transmission of the tips for the pools and the results of the ice-hockey matches every time the data are updated. This has been implemented so that when the data of the service page change, the server 25 contacts the communicator 13 through the mobile network 100, 104, 105. The communicator 13 identifies, on the basis of the CLIP identifier it receives, that the teleservice presented above is being transmitted. The communicator 13 according to the present invention transmits to the user, controlled by the processor 131, a specific ringing tone to inform that the service has been activated and to distinguish the service from an ordinary incoming call. The program code, stored in the memory 132 of the communicator 13, can be set on automatic response, whereupon it is possible to utilize the service completely without the user being actively involved. After this, the communicator 13 retrieves, e.g., from the URL address, agreed upon when making the service contract and stored in the memory 132 of the communicator 13, the service page comprising the tips for the pools and the results of the matches by means of the service page transmission method according to the present invention and displays it on its display 17 (folded with the small display 135). Thus, the user of the communicator 13 always receives automatically the results of the matches in real-time. A similar type of service is also suitable for advertising purposes. In that case, a service provider can transmit, e.g., a price-list that is changed monthly to all prospective customers using a terminal capable of transmitting service pages on the basis of a CLIP identifier according to the present invention.

**[0030]** In the detailed specification of the present invention, we have described many different types of services that provide for the versatile service pages 70 to be transmitted to the subscriber B on the basis of the information transmitted by the CLIP service. By means of the service page transmission method according to the present invention, it is also possible to transmit the service pages 70 to the subscriber A on the basis of the CoLP service of the GSM system as already stated in the short summary of the invention. In this case, the implementation of the invention substantially complies with the solutions presented in connection with Figures 2-8. Figure 9 illustrates, in the form of a flowchart, the transmission of a service page, linked with the subscriber B, to the subscriber A on the basis of the CoLP information. The flowchart, illustrated in Figure 9, can be applied to the third and fourth embodiments of the present invention presented in the short summary of the invention.

**[0031]** This paper presents the implementation and embodiments of the present invention with the help of examples. It is obvious to a person skilled in the art that the present invention is not restricted to details of the embodiments presented above, and that the invention can also be implemented in another form without deviating from the characteristics of the invention. The embodiments presented should be considered illustrative, but not restricting. Thus, the possibilities of implementing and using the invention are only restricted by the enclosed claims. Consequently, the various options of implementing the invention as determined by the claims, including the equivalent implementations, also belong to the scope of the invention.

## Claims

1. An information transmission system comprising :

- a first terminal (10, 11, 12, 13, 14, 15, 20, 21, 22),
- a second terminal (10, 11, 12, 13, 14, 15, 20, 21, 22),
- communication connection set-up means (26, 100, 104, 105, 110, 120, 133, 134) for setting up a communication connection between said first terminal (10, 11, 12, 13, 14, 15, 20, 21, 22) and said second terminal (10, 11, 12, 13, 14, 15, 20, 21, 22), said communication connection set-up means (26, 100, 104, 105, 110, 120, 133, 134) being arranged to transmit a network subscriber identifier (42, 51, 53) that is characteristic of said first terminal (10, 11, 12, 13, 14, 15, 20, 21, 22) to said second terminal (10, 11, 12, 13, 14, 15, 20, 21, 22), and
- a server (20, 21, 22, 24, 25) for storing and transmitting service pages (70), said server being connected to said communication connection set-up means (26, 100, 104, 105, 110, 120, 133, 134)

### characterised in that:

- the information transmission system comprises means for enabling a user of said first terminal or a user of said second terminal to select a service page an address of which is linked to said network subscriber identifier (42, 51, 53), said service page being stored in said server and being retrievable from said server by using the address of said service page,
- the information transmission system comprises means for retrieving the address of said service page from a reference table by using said network subscriber identifier (42, 51, 53), and
- said communication connection set-up means (26, 100, 104, 105, 110, 120, 133, 134) are adapted to transfer said service page (70) from said server to at least one of the following: said first terminal (10, 11, 12, 13, 14, 15, 20, 21, 22) and said second terminal (10, 11, 12, 13, 14, 15, 20, 21, 22).

2. An information transmission system according to claim 1, **characterised in that** said network subscriber identifier (42, 51, 53) is one of the following: CLIP (Calling Line identification Presentation) information and CoLP (Connected Line Identification Presentation) information.
- 5 3. An information transmission system according to claim 1 or 2, **characterised in that** said reference table comprises a reference database (50) for storing said network subscriber identifier (42, 51, 53) and the address of said service page and that said reference database (50) is located in one of the following parts of the information transmission system: said first terminal (10, 11, 12, 13, 14, 15, 20, 21, 22) and said server (20, 21, 22, 24, 25).
- 10 4. An information transmission system according to claim 3, **characterised in that** it comprises a mobile services switching centre (100) and storage means (101, 53, 54) and that said reference database (50) is located in said storage means (101, 53, 54).
- 15 5. An information transmission system according to claim 3 or 4, **characterised in that** said communication connection set-up means (26, 100, 104, 105, 110, 120, 133, 134) are adapted to transmit said service page (70) from an address specified by address information (41, 52, 54) stored in said reference database (50).
- 20 6. An information transmission system according to claim 4 or 5, **characterised in that** it comprises means for editing said reference database (50) and for rendering the editing rights and that one of the following has been arranged to edit said reference database (50): said first terminal (10, 11, 12, 13, 14, 15, 20, 21, 22), said second terminal (10, 11, 12, 13, 14, 15, 20, 21, 22) and said server (20, 21, 22, 24, 25).
7. A terminal (10, 11, 12, 13, 14, 15, 20, 21, 22) comprising:
- 25 - means (131, 132, 133, 134) for setting up a connection and for transmitting and receiving information to and from a telecommunication network (26, 100, 104, 105, 110, 120), and  
- means (131, 132, 133, 134) for receiving a network subscriber identifier (42, 51, 53) from said telecommunication network (26, 100, 104, 105, 110, 120),
- 30 **characterised in that** the terminal further comprises:
- means for enabling a user of the terminal to select a service page an address of which is linked to said network subscriber identifier (42, 51, 53), said service page being stored in said telecommunication network and being retrievable from said telecommunication network by using information defining the address of said service page,  
35 and  
- means (131, 132, 133, 134) for retrieving said service page (70) from said telecommunication network (26, 100, 104, 105, 110, 120), said network subscriber identifier representing the information defining the address of said service page as being linked to the address.
- 40 8. A method for transmitting information, **characterised in that** the method comprises:
- enabling a user of a first terminal (10, 11, 12, 13, 14, 15, 20, 21, 22) or a user of a second terminal (10, 11, 12, 13, 14, 15, 20, 21, 22) to select a service page an address of which is linked to a network subscriber identifier (42, 51, 53) that is characteristic of said first terminal, said service page being stored in a telecommunication network and being retrievable from said telecommunication network by using the address of said service page,  
45 - setting up a communication connection (26, 100, 104, 105, 110, 120) between said first terminal and said second terminal,  
- transferring said network subscriber identifier to said second terminal,  
- retrieving the address of said service page from a reference table by using said network subscriber identifier, and  
50 - retrieving said service page from said telecommunication network by using the address of said service page.
9. A method for transmitting information according to claim 8, **characterised in that** said network subscriber identifier (42, 51, 53) is one of the following: CLIP (Calling Line Identification Presentation) information and CoLP (Connected Line Identification Presentation) information.
- 55 10. A method for transmitting information according to claim 8 or 9, **characterised in that** the reference table comprises a separate reference database (50).

11. A server (20, 21, 22, 24, 25) for an information transmission system, the information transmission system comprising:

- a first terminal (10, 11, 12, 13, 14, 15, 20, 21, 22),
- a second terminal (10, 11, 12, 13, 14, 15, 20, 21, 22), and
- communication connection set-up means (26, 100, 104, 105, 110, 120, 133, 134) for setting up communication connections between said first terminal, said second terminal, and the server, said communication connection set-up means being adapted to transmit a network subscriber identifier (42, 51, 53) that is characteristic of said first terminal to said second terminal,

characterised in that the server (20, 21, 22, 24, 25) comprises:

- means for enabling a user of the first terminal or the user of the second terminal to select a service page an address of which is linked to said network subscriber identifier (42, 51, 53), said service page being stored in a telecommunication network and being retrievable from said telecommunication network by using the address of said service page, and
- means for maintaining a reference table for storing the address of said service page and said network subscriber identifier.

12. A computer program product for a server (20, 21, 22, 24, 25) for an information transmission system, the information transmission system comprising:

- a first terminal (10, 11, 12, 13, 14, 15, 20, 21, 22),
- a second terminal (10, 11, 12, 13, 14, 15, 20, 21, 22), and
- communication connection set-up means (26, 100, 104, 105, 110, 120, 133, 134) for setting up communication connections between said first terminal, said second terminal, and said server, said communication connection set-up means being adapted to transmit a network subscriber identifier (42, 51, 53) that is characteristic of said first terminal, to said second terminal,

characterised in that the computer program product comprises computer program code adapted:

- to make the server to enable a user of the first terminal or the user of the second terminal to select a service page an address of which is linked to said network subscriber identifier (42, 51, 53), said service page being stored in a telecommunication network and being retrievable from said telecommunication network by using the address of said service page, and
- to make the server to maintain a reference table for storing the address of said service page and said network subscriber identifier.

13. A computer program product for a terminal (10, 11, 12, 13, 14, 15, 20, 21, 22), the terminal comprising:

- means (131, 132, 133, 134) for setting up a connection and for transmitting and receiving information to and from a telecommunication network (26, 100, 104, 105, 110, 120), and
- means (131, 132, 133, 134) for receiving a network subscriber identifier (42, 51, 53) from said telecommunication network (26, 100, 104, 105, 110, 120),

characterised in that the computer program product comprises computer program code adapted:

- to make the terminal to enable a user of the terminal to select a service page an address of which is linked to said network subscriber identifier (42, 51, 53), said service page being stored in said telecommunication network and being retrievable from said telecommunication network by using information defining the address of said service page, and
- to make the terminal to retrieve said service page (70) from said telecommunication network (26, 100, 104, 105, 110, 120), said network subscriber identifier representing the information defining the address of said service page as being linked to the address..

55

## Patentansprüche

1. Datenübertragungssystem umfassend:

- eine erste Benutzeroberfläche (10, 11, 12, 13, 14, 15, 20, 21, 22),
  - eine zweite Benutzeroberfläche (10, 11, 12, 13, 14, 15, 20, 21, 22),
  - Mittel zum Aufbau von Kommunikationsverbindungen (26, 100, 104, 105, 110, 120, 133, 134), um eine Kommunikationsverbindung zwischen der ersten Benutzeroberfläche (10, 11, 12, 13, 14, 15, 20, 21, 22) und der zweiten Benutzeroberfläche (10, 11, 12, 13, 14, 15, 20, 21, 22) einzurichten, wobei die Mittel zum Aufbau einer Kommunikationsverbindung (26, 100, 104, 105, 110, 120, 133, 134) so angeordnet sind, um einen Netzwerkeinschreibungsidentifikator (42, 51, 53), der bezeichnend für die erste Benutzeroberfläche (10, 11, 12, 13, 14, 15, 20, 21, 22) ist, an die zweite Benutzeroberfläche (10, 11, 12, 13, 14, 15, 20, 21, 22), zu übermitteln, und
  - ein Server (20, 21, 22, 24, 25) zur Speicherung und Übertragung von Angebotsseiten (70), wobei der Server mit den Mitteln zum Aufbau einer Kommunikationsverbindung (26, 100, 104, 105, 110, 120, 133, 134) verbunden ist, **dadurch gekennzeichnet, dass:**
    - das Datenübertragungssystem Mittel umfasst, um einem Benutzer der ersten Benutzeroberfläche oder einem Benutzer der zweiten Benutzeroberfläche zu ermöglichen, eine Adresse einer Angebotsseite auszuwählen, von welcher auf den Netzwerkeinschreibungsidentifikator (42, 51, 53) verwiesen wird, wobei die Angebotsseite auf dem Server gespeichert ist und von dem Server wieder abgerufen werden kann, indem die Adresse der Angebotsseite verwendet wird,
    - das Datenübertragungssystem Mittel zum Wiederaufrufen der Adresse der Angebotsseite von einer Verweistabelle unter Verwendung des Netzwerkeinschreibungsidentifikators (42, 51, 53) umfasst, und
    - die Mittel zum Aufbau einer Kommunikationsverbindung (26, 100, 104, 105, 110, 120, 133, 134) so angepasst sind, um die Angebotsseite (70) von dem Server auf mindestens eine der folgenden zu übertragen: auf die erste Benutzeroberfläche (10, 11, 12, 13, 14, 15, 20, 21, 22) und die zweite Benutzeroberfläche (10, 11, 12, 13, 14, 15, 20, 21, 22).
2. Datenübertragungssystem nach Anspruch 1, **dadurch gekennzeichnet, dass** der Netzwerkeinschreibungsidentifikator (42, 51, 53) einer der Folgenden ist: CLIP-Daten (Calling Line Identification Presentation - Anzeige der Rufnummer des Anrufers beim Angerufenen) und CoLP-Daten (Connected Line Identification Presentation - Anzeige der Rufnummer des Angerufenen beim Anrufer).
  3. Datenübertragungssystem nach Anspruch 1 oder 2, **dadurch gekennzeichnet, dass** die Verweistabelle eine Verweisdatenbank (50) umfasst, um den Netzwerkeinschreibungsidentifikator (42, 51, 53) und die Adresse der Angebotsseite zu speichern und dass die Verweisdatenbank (50) in einer der folgenden Teile des Datenübertragungssystems angesiedelt ist: in der ersten Benutzeroberfläche (10, 11, 12, 13, 14, 15, 20, 21, 22) und dem Server.
  4. Datenübertragungssystem nach Anspruch 3, **dadurch gekennzeichnet, dass** es ein mobiles Dienstvermittlungszentrum (100) und Mittel zur Speicherung (101, 53, 54) umfasst, und dass die Verweisdatenbank (50) in den Mitteln zur Speicherung (101, 53, 54) angesiedelt ist.
  5. Datenübertragungssystem nach Anspruch 3 oder 4, **dadurch gekennzeichnet, dass** die Mittel zum Aufbau einer Kommunikationsverbindung (26, 100, 104, 105, 110, 120, 133, 134) so angepasst sind, um die Angebotsseite (70) von einer bestimmten Adresse mittels einer Adressinformation (41, 52, 54) zu übertragen, die in der Verweisdatenbank (50) gespeichert ist.
  6. Datenübertragungssystem nach Anspruch 4 oder 5, **dadurch gekennzeichnet, dass** es Mittel zur Bearbeitung der Verweisdatenbank (50) und zur Wiedergabe von Bearbeitungsrechten umfasst, und dass eine der Folgenden so angeordnet wurde, um die Verweisdatenbank (50) zu bearbeiten: die erste Benutzeroberfläche (10, 11, 12, 13, 14, 15, 20, 21, 22), die zweite Benutzeroberfläche (10, 11, 12, 13, 14, 15, 20, 21, 22) und der Server (20, 21, 22, 24, 25).
  7. Benutzeroberfläche (10, 11, 12, 13, 14, 15, 20, 21, 22) umfassend:
    - Mittel (131, 132, 133, 134) zum Aufbau einer Verbindung und zur Übertragung und Empfang von Daten an und von einem Telekommunikationsnetzwerk (26, 104, 105, 110, 120), und
    - Mittel (131, 132, 133, 134) zum Empfang eines Netzwerkeinschreibungsidentifikators (42, 51, 53) von dem Telekommunikationsnetzwerk (26, 100, 104, 105, 110, 120), **dadurch gekennzeichnet, dass** die Benutzeroberfläche ferner umfasst:
      - Mittel um einem Benutzer der Benutzeroberfläche zu ermöglichen, eine Adresse einer Angebotsseite auszuwählen, von welcher auf den Netzwerkeinschreibungsidentifikator (42, 51, 53) verwiesen wird, die Angebotsseite in dem Telekommunikationsnetzwerk gespeichert ist und von dem Telekommunikationsnetzwerk wieder abruf-

bar ist, indem Daten verwendet werden, die die Adresse der Angebotsseite definieren, und  
 - Mittel (131, 132, 133, 134) zum Wiederaufrufen der Angebotsseite (70) von dem Telekommunikationsnetzwerk  
 (26, 100, 104, 105, 110, 120), wobei der Netzwerkeinschreibungsidentifikator die Daten darstellt, die die Adresse  
 der Angebotsseite definieren, so wie mit der Adresse verknüpft ist.

5

8. Verfahren zur Übermittlung von Daten, **dadurch gekennzeichnet, dass** das Verfahren umfasst:

- es einem Benutzer einer ersten Benutzeroberfläche (10, 11, 12, 13, 14, 15, 20, 21, 22) oder einem Benutzer einer zweiten Benutzeroberfläche (10, 11, 12, 13, 14, 15, 20, 21, 22) zu ermöglichen, eine Adresse einer Angebotsseite auszuwählen, von welcher auf einen Netzwerkeinschreibungsidentifikator (42, 51, 53) verwiesen wird, der für die erste Benutzeroberfläche bezeichnend ist, wobei die Angebotsseite in einem Telekommunikationsnetzwerk gespeichert ist, und von dem Telekommunikationsnetzwerk wiederabrufbar ist, indem die Adresse der Angebotsseite verwendet wird,
- Aufbau einer Kommunikationsverbindung (26, 100, 104, 105, 110, 120) zwischen der ersten Benutzeroberfläche und der zweiten Benutzeroberfläche,
- Übermittlung des Netzwerkeinschreibungsidentifikators an eine zweite Benutzeroberfläche,
- Wiederaufrufen der Adresse der Angebotsseite von einer Verweistabelle unter Verwendung des Netzwerkeinschreibungsidentifikators, und
- Wiederaufrufen der Angebotsseite von dem Telekommunikationsnetzwerk unter Verwendung der Adresse der Angebotsseite.

10

15

20

9. Verfahren zur Übertragung von Daten nach Anspruch 8, **dadurch gekennzeichnet, dass** der Netzwerkeinschreibungsidentifikator (42, 51, 53) einer der Folgenden ist: CLIP-Daten (Calling Line Identification Presentation - Anzeige der Rufnummer des Anrufers beim Angerufenen) und CoLP-Daten (Connected Line Identification Presentation - Anzeige der Rufnummer des Angerufenen beim Anrufer).

25

10. Verfahren zur Übertragung von Daten nach Anspruch 8 oder 9, **dadurch gekennzeichnet, dass** die Verweistabelle eine separate Verweisdatenbank (50) umfasst.

30

11. Server (20, 21, 22, 24, 25) für ein Datenübertragungssystem, das Datenübertragungssystem umfassend:

- eine erste Benutzeroberfläche (10, 11, 12, 13, 14, 15, 20, 21, 22),
- eine zweite Benutzeroberfläche (10, 11, 12, 13, 14, 15, 20, 21, 22), und
- Mittel zum Aufbau einer Kommunikationsverbindung (26, 100, 104, 105, 110, 120, 133, 134), um Kommunikationsverbindungen zwischen der ersten Benutzeroberfläche, der zweiten Benutzeroberfläche und dem Server aufzubauen, wobei die Mittel zum Aufbau der Kommunikationsverbindung angepasst sind, um einen Netzwerkeinschreibungsidentifikator (42, 51, 53) zu übertragen, der **gekennzeichnet** ist, dass der Server (20, 21, 22, 24, 25) umfasst:
- Mittel um einem Benutzer der ersten Benutzeroberfläche oder dem Benutzer der zweiten Benutzeroberfläche zu ermöglichen, eine Serviceseite einer Adresse auszuwählen, von welcher auf den Netzwerkeinschreibungsidentifikator (42, 51, 53) verwiesen wird, wobei die Serviceseite in einem Telekommunikationsnetzwerk gespeichert ist und von dem Telekommunikationsnetzwerk wiederabrufbar ist, indem die Adresse der Serviceseite verwendet wird, und
- Mittel um eine Verweistabelle zu pflegen, um die Adresse der Serviceseite und des Netzwerkeinschreibungsidentifikators zu speichern.

35

40

45

12. Computerprogrammprodukt für einen Server (20, 21, 22, 24, 25) für ein Datenübertragungssystem, das Datenübertragungssystem umfassend:

- eine erste Benutzeroberfläche (10, 11, 12, 13, 14, 15, 20, 21, 22),
- eine zweite Benutzeroberfläche (10, 11, 12, 13, 14, 15, 20, 21, 22), und
- Mittel zum Aufbau einer Kommunikationsverbindung (26, 100, 104, 105, 110, 120, 133, 134) zum Aufbau von Kommunikationsverbindungen zwischen der ersten Benutzeroberfläche, der zweiten Benutzeroberfläche, und dem Server, wobei die Mittel zum Aufbau einer Kommunikationsverbindung so angepasst sind, um einen Netzwerkeinschreibungsidentifikator (42, 51, 53), der für die erste Benutzeroberfläche bezeichnend ist, an die zweite Benutzeroberfläche zu übermitteln,

50

55

**dadurch gekennzeichnet, dass** das Computerprogrammprodukt einen Computerprogrammcode umfasst, so an-

gepasst:

- den Server so einzurichten, dass es dem Benutzer der ersten Benutzeroberfläche oder dem Benutzer der zweiten Benutzeroberfläche möglich ist, eine Adresse einer Angebotsseite auszuwählen, von welcher auf den Netzwerkeinschreibungsidentifikator (42, 51, 53) verwiesen wird, wobei die Angebotsseite in einem Telekommunikationsnetzwerk gespeichert ist und von dem Telekommunikationsnetzwerk wiederaufrufbar ist, unter Verwendung der Adresse der Angebotsseite, und
- den Server so einzurichten, um eine Verweistabelle zur Speicherung der Adresse der Angebotsseite und des Netzwerkeinschreibungsidentifikators zu pflegen.

13. Computerprogrammprodukt für eine Benutzeroberfläche (10, 11, 12, 13, 14, 15, 20, 21, 22), die Benutzeroberfläche umfassend:

- Mittel (131, 132, 133, 134) zum Aufbau einer Verbindung und zur Übertragung und Empfang von Daten zu und von einem Telekommunikationsnetzwerk (26, 100, 104, 105, 110, 120), und
- Mittel (131, 132, 133, 134) zum Empfang eines Netzwerkeinschreibungsidentifikators (42, 51, 53) von dem Telekommunikationsnetzwerk (26, 100, 104, 105, 110, 120), **dadurch gekennzeichnet, dass** das Computerprogrammprodukt einen Computerprogrammcode umfasst, der so angepasst ist:

- die Benutzeroberfläche so einzurichten, um dem Benutzer der Benutzeroberfläche zu ermöglichen, eine Adresse einer Angebotsseite auszuwählen, von welcher auf den Netzwerkeinschreibungsidentifikator (42, 51, 53) verwiesen wird, wobei die Angebotsseite in dem Telekommunikationsnetzwerk gespeichert ist und von dem Telekommunikationsnetzwerk wiederaufrufbar ist, unter Verwendung von Daten, die die Adresse der Angebotsseite definieren, und
- eine Benutzeroberfläche so einzurichten, um die Angebotsseite (70) von dem Telekommunikationsnetzwerk (26, 100, 104, 105, 110, 120) wiederaufzurufen, wobei der Netzwerkeinschreibungsidentifikator die Daten repräsentiert, die die Adresse der Angebotsseite definieren, so wie sie mit der Adresse verknüpft ist.

### 30 Revendications

1. Système de transmission d'information comportant :

- un premier terminal (10, 11, 12, 13, 14, 15, 20, 21, 22),
- un second terminal (10, 11, 12, 13, 14, 15, 20, 21, 22),
- des moyens d'établissement de connexion de communication (26, 100, 104, 105, 110, 120, 133, 134) permettant d'établir une connexion de communication entre ledit premier terminal (10, 11, 12, 13, 14, 15, 20, 21, 22) et ledit second terminal (10, 11, 12, 13, 14, 15, 20, 21, 22), lesdits moyens d'établissement de connexion de communication (26, 100, 104, 105, 110, 120, 133, 134) étant disposés pour transmettre un identificateur d'abonné de réseau (42, 51, 53) lequel est caractéristique dudit premier terminal (10, 11, 12, 13, 14, 15, 20, 21, 22) audit second terminal (10, 11, 12, 13, 14, 15, 20, 21, 22), et
- un serveur (20, 21, 22, 24, 25) permettant de stocker et de transmettre des messages de service (70), ledit serveur étant connecté auxdits moyens d'établissement de connexion de communication (26, 100, 104, 105, 110, 120, 133, 134),

caractérisé en ce que:

- le système de transmission d'information comporte des moyens permettant à un utilisateur dudit premier terminal ou à un utilisateur dudit second terminal de sélectionner un message de service dont une adresse est interconnectée audit identificateur d'abonné de réseau (42, 51, 53), ledit message de service étant stocké dans ledit serveur et étant récupérable à partir dudit serveur au moyen de l'adresse dudit message de service,
- le système de transmission d'information comporte des moyens permettant de récupérer l'adresse dudit message de service à partir d'un tableau de référence au moyen dudit identificateur d'abonné de réseau (42, 51, 53), et
- lesdits moyens d'établissement de connexion de communication (26, 100, 104, 105, 110, 120, 133, 134) sont adaptés pour transférer ledit message de service (70) à partir dudit serveur à au moins un parmi les suivants : ledit premier terminal (10, 11, 12, 13, 14, 15, 20, 21, 22) et ledit second terminal (10, 11, 12, 13, 14, 15, 20, 21, 22).



## EP 0 869 688 B1

2. Système de transmission d'information selon la revendication 1, **caractérisé en ce que** ledit identificateur d'abonné de réseau (42, 51, 53) est l'un parmi ce qui suit : une information de présentation d'identification de la ligne appelante (CLIP) et une information de présentation d'identification de la ligne connectée (CoLP).
- 5 3. Système de transmission d'information selon la revendication 1 ou 2, **caractérisé en ce que** ledit tableau de référence comporte une base de données de référence (50) pour stocker ledit identificateur d'abonné de réseau (42, 51, 53) et l'adresse dudit message de service et **en ce que** ladite base de données de référence (50) est située dans l'une des parties suivantes du système de transmission d'information: ledit premier terminal (10, 11, 12, 13, 14, 15, 20, 21, 22) et ledit serveur (20, 21, 22, 24, 25).
- 10 4. Système de transmission d'information selon la revendication 3, **caractérisé en ce qu'il** comporte un centre de commutation de services mobiles (100) et des moyens de stockage (101, 53, 54) et **en ce que** ladite base de données de référence (50) est située dans lesdits moyens de stockage (101, 53, 54).
- 15 5. Système de transmission d'information selon la revendication 3 ou 4, **caractérisé en ce que** lesdits moyens d'établissement de connexion de communication (26, 100, 104, 105, 110, 120, 133, 134) sont adaptés pour transmettre ledit message de service (70) à partir d'une adresse spécifiée par une information d'adresse (41, 52, 54) stockée dans ladite base de données de référence (50).
- 20 6. Système de transmission d'information selon la revendication 4 ou 5, **caractérisé en ce qu'il** comporte des moyens pour éditer ladite base de données de référence (50) et pour rendre les droits d'édition et **en ce que** l'un parmi les éléments suivants a été disposé pour éditer ladite base de données de référence (50): ledit premier terminal (10, 11, 12, 13, 14, 15, 20, 21, 22), ledit second terminal (10, 11, 12, 13, 14, 15, 20, 21, 22) et ledit serveur (20, 21, 22, 24, 25).
- 25 7. Terminal (10, 11, 12, 13, 14, 15, 20, 21, 22) comportant :
- des moyens (131, 132, 133, 134) pour établir une connexion et pour transmettre et recevoir de l'information à, et à partir de, un réseau de télécommunication (26, 100, 104, 105, 110, 120), et
  - 30 - des moyens (131, 132, 133, 134) pour recevoir un identificateur d'abonné de réseau (42, 51, 53) à partir dudit réseau de télécommunication (26, 100, 104, 105, 110, 120),
- caractérisé en ce que** le terminal comporte en outre :
- 35 - des moyens pour permettre à un utilisateur du terminal de sélectionner un message de service dont une adresse est interconnectée audit identificateur d'abonné de réseau (42, 51, 53), ledit message de service étant stocké dans ledit réseau de télécommunication et étant récupérable à partir dudit réseau de télécommunication au moyen d'information définissant l'adresse dudit message de service, et
- 40 - des moyens (131, 132, 133, 134) pour récupérer ledit message de service (70) à partir dudit réseau de télécommunication (26, 100, 104, 105, 110, 120), ledit identificateur d'abonné de réseau représentant l'information définissant l'adresse dudit message de service comme étant interconnectée à l'adresse.
8. Procédé permettant de transmettre des informations, **caractérisé en ce que** le procédé comporte les étapes consistant à :
- 45 - permettre à un utilisateur d'un premier terminal (10, 11, 12, 13, 14, 15, 20, 21, 22) ou à un utilisateur d'un second terminal (10, 11, 12, 13, 14, 15, 20, 21, 22) de sélectionner un message de service dont une adresse est interconnectée à un identificateur d'abonné de réseau (42, 51, 53) lequel est caractéristique dudit premier terminal, ledit message de service étant stocké dans un réseau de télécommunication et étant récupérable à partir dudit réseau de télécommunication au moyen de l'adresse dudit message de service,
- 50 - établir une connexion de communication (26, 100, 104, 105, 110, 120) entre ledit premier terminal et ledit second terminal,
- transférer ledit identificateur d'abonné de réseau audit second terminal,
  - récupérer l'adresse dudit message de service à partir d'un tableau de référence au moyen dudit identificateur d'abonné de réseau, et
  - 55 - récupérer ledit message de service à partir dudit réseau de télécommunication au moyen de l'adresse dudit message de service.

## EP 0 869 688 B1

9. Procédé pour transmettre de l'information selon la revendication 8, **caractérisé en ce que** ledit identificateur d'abonné de réseau (42, 51, 53) est l'un parmi les éléments suivants : une information de présentation d'identification de la ligne appelante (CLIP) et une information de présentation d'identification de la ligne connectée (CoLP).
- 5 10. Procédé pour transmettre de l'information selon la revendication 8 ou 9, **caractérisé en ce que** le tableau de référence comporte une base de données de référence séparée (50).
11. Serveur (20, 21, 22, 24, 25) d'un système de transmission d'information, le système de transmission d'informations comportant :
- 10 - un premier terminal (10, 11, 12, 13, 14, 15, 20, 21, 22),  
- un second terminal (10, 11, 12, 13, 14, 15, 20, 21, 22), et  
- des moyens d'établissement de connexion de communication (26, 100, 104, 105, 110, 120, 133, 134) pour établir des connexions de communications entre ledit premier terminal, ledit second terminal, et le serveur,  
15 lesdits moyens d'établissement de connexion de communication étant adaptés pour transmettre un identificateur d'abonné de réseau (42, 51, 53) lequel est caractéristique dudit premier terminal audit second terminal,
- caractérisé en ce que** le serveur (20, 21, 22, 24, 25) comporte :
- 20 - des moyens pour permettre à un utilisateur du premier terminal ou à l'utilisateur du second terminal de sélectionner un message de service dont une adresse est interconnectée audit identificateur d'abonné de réseau (42, 51, 53), ledit message de service étant stocké dans un réseau de télécommunication et étant récupérable à partir dudit réseau de télécommunication au moyen de l'adresse dudit message de service, et  
25 - des moyens pour entretenir un tableau de référence pour stocker l'adresse dudit message de service et ledit identificateur d'abonné de réseau.
12. Produit de programme informatique relatif à un serveur (20, 21, 22, 23, 24, 25) pour un système de transmission d'information, ledit système de transmission d'information comportant :
- 30 - un premier terminal (10, 11, 12, 13, 14, 15, 20, 21, 22),  
- un second terminal (10, 11, 12, 13, 14, 15, 20, 21, 22), et  
- des moyens d'établissement de connexion de communication (26, 100, 104, 105, 110, 120, 133, 134) afin d'établir des connexions de communication entre ledit premier terminal, ledit second terminal, et ledit serveur,  
35 lesdits moyens d'établissement de connexion de communication étant adaptés pour transmettre un identificateur d'abonné de réseau (42, 51, 53) qui est caractéristique dudit premier terminal, audit second terminal,
- caractérisé en ce que** le produit programme informatique comporte un code de programme informatique adapté :
- 40 - pour forcer le serveur à permettre à un utilisateur du premier terminal ou l'utilisateur du second terminal de sélectionner un message de service dont une adresse est interconnectée audit identificateur d'abonné de réseau (42, 51, 53), ledit message de service étant stocké dans un réseau de télécommunication et étant récupérable à partir dudit réseau de télécommunication au moyen de l'adresse dudit message de service, et  
45 - pour forcer le serveur à maintenir un tableau de référence pour stocker l'adresse dudit message de service et ledit identificateur d'abonné de réseau.
13. Produit de programme informatique relatif à un terminal (10, 11, 12, 13, 14, 15, 20, 21, 22) ledit terminal comportant :
- 50 - des moyens (131, 132, 133, 134) pour établir une connexion et pour transmettre et recevoir de l'information à, et à partir de, un réseau de télécommunication (26, 100, 104, 105, 110, 120), et  
- des moyens (131, 132, 133, 134) pour recevoir un identificateur d'abonné de réseau (42, 51, 53) à partir dudit réseau de télécommunication (26, 100, 104, 105, 110, 120),
- caractérisé en ce que** le produit programme informatique comporte un code de programme informatique adapté :
- 55 - pour forcer le terminal à permettre à un utilisateur du terminal de sélectionner un message de service dont une adresse est interconnectée audit identificateur d'abonné de réseau (42, 51, 53), ledit message de service étant stocké dans ledit réseau de télécommunication et étant récupérable à partir dudit réseau de télécommunication au moyen d'informations définissant l'adresse dudit message de service, et

**EP 0 869 688 B1**

- pour forcer le terminal à récupérer ledit message de service (70) à partir dudit réseau de télécommunication (26, 100, 104, 105, 110, 120), ledit identificateur d'abonné de réseau représentant l'information définissant l'adresse dudit message de service comme étant liée à l'adresse.

5

10

15

20

25

30

35

40

45

50

55

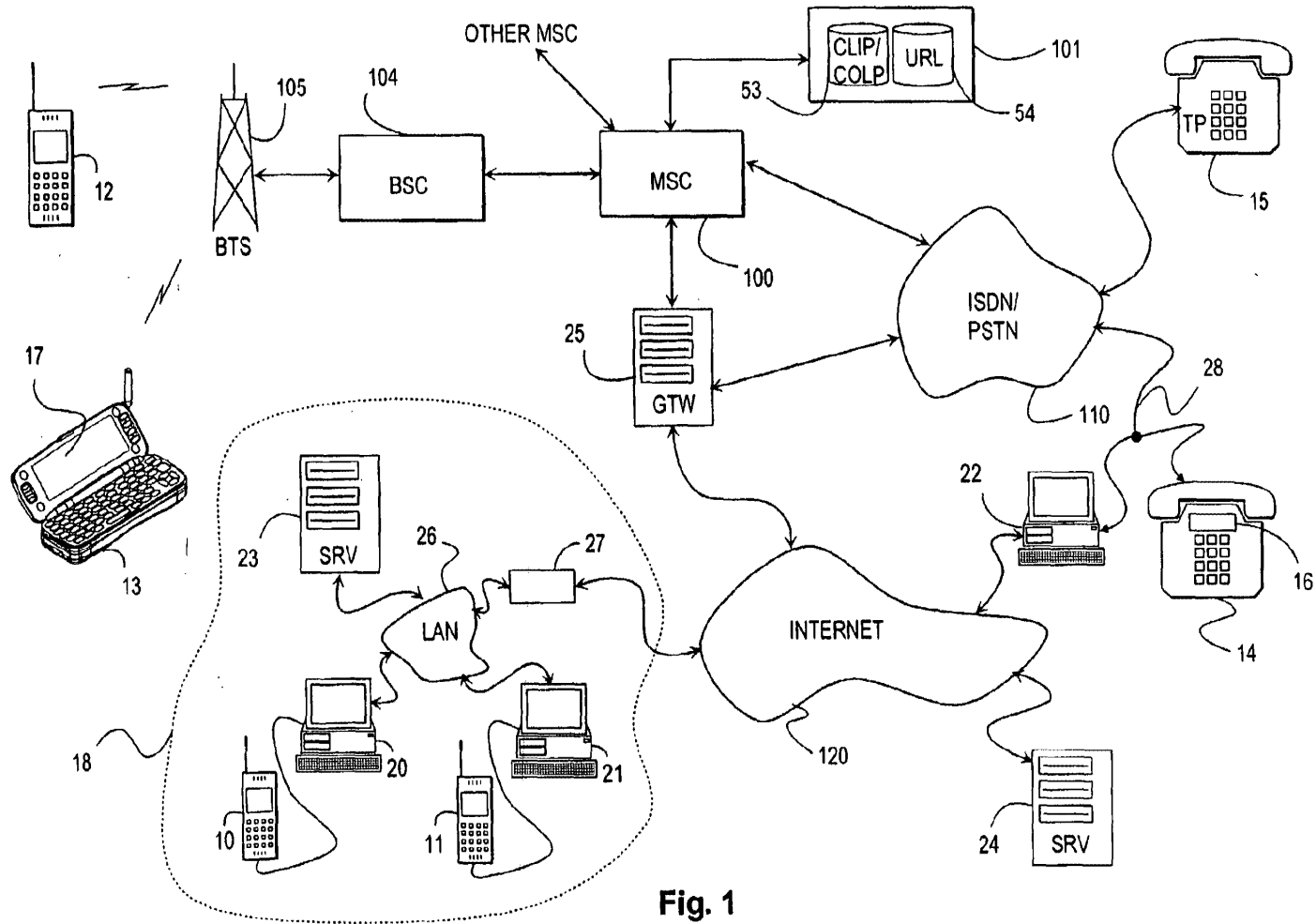


Fig. 1

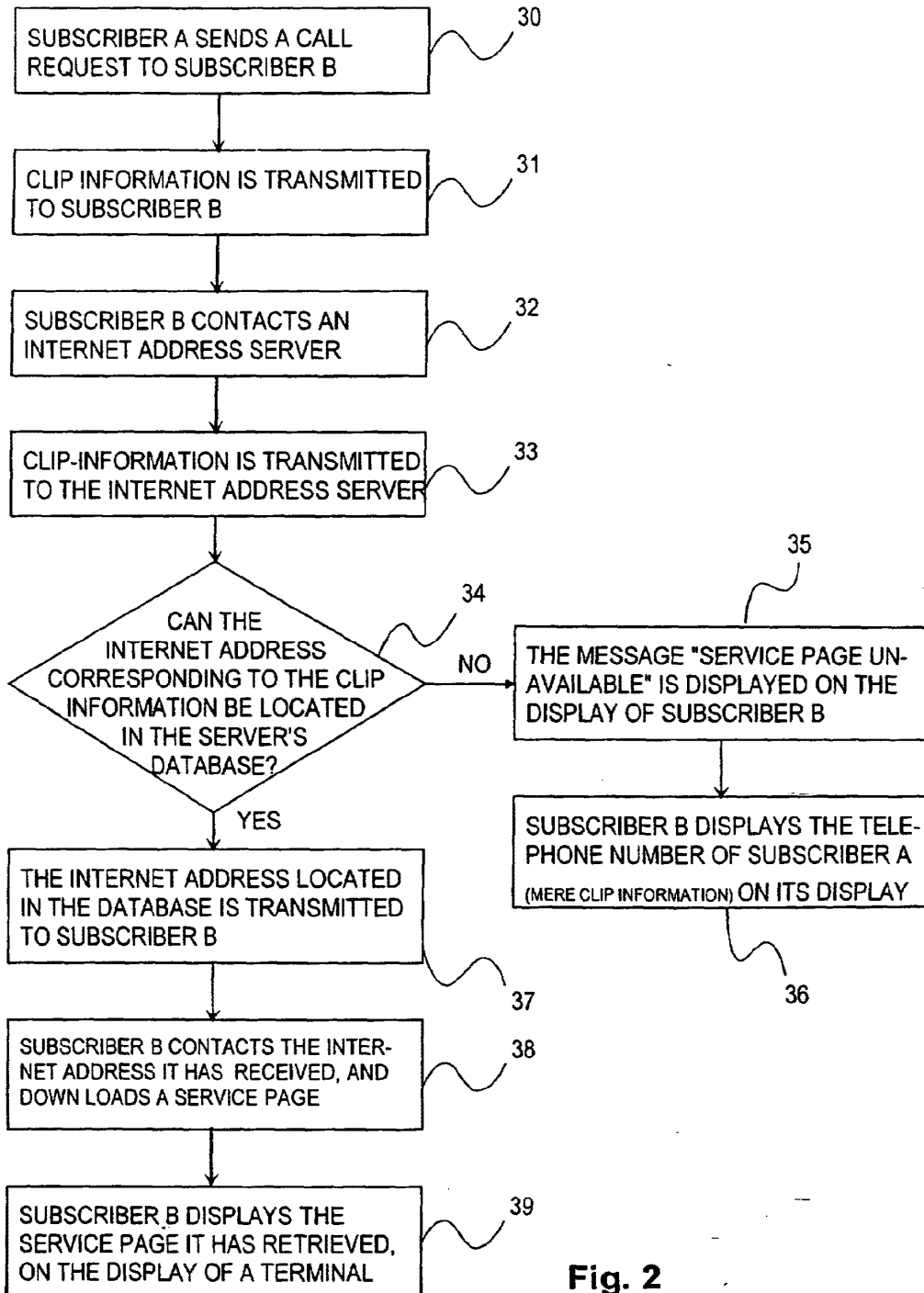
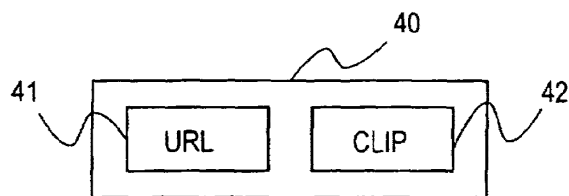
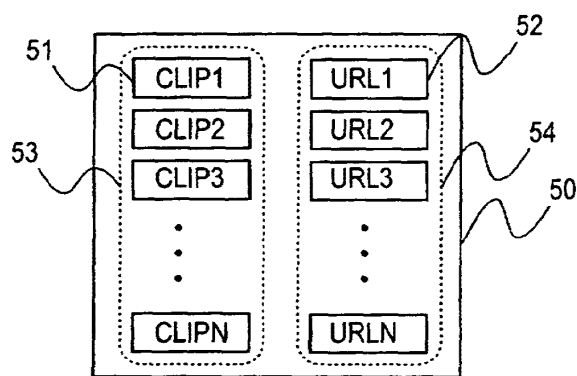


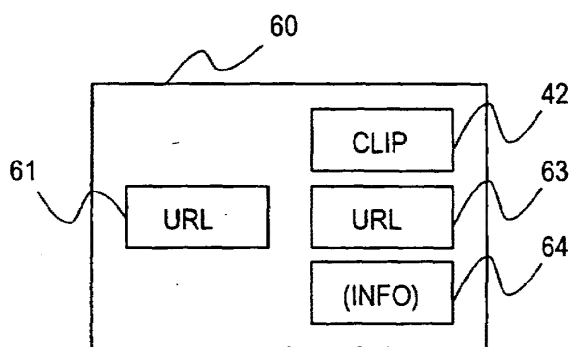
Fig. 2



**Fig. 3**



**Fig. 4**



**Fig. 5**

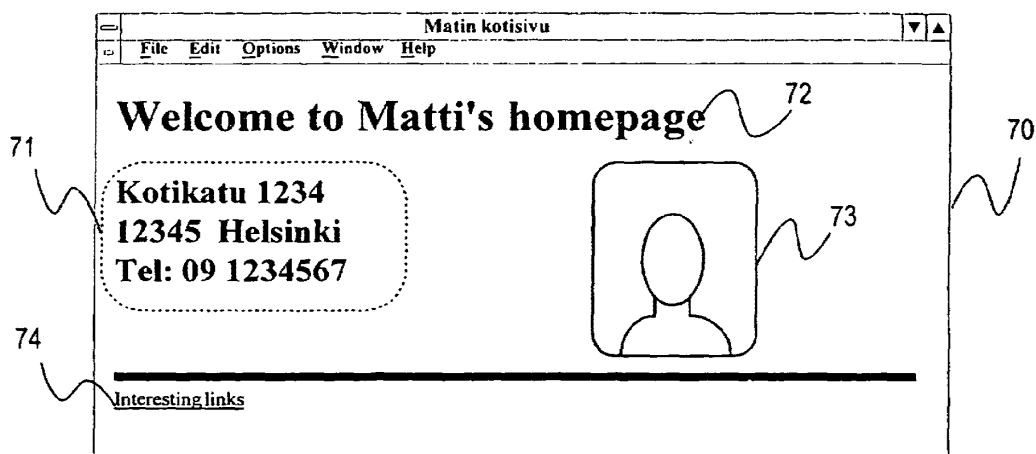


Fig. 6

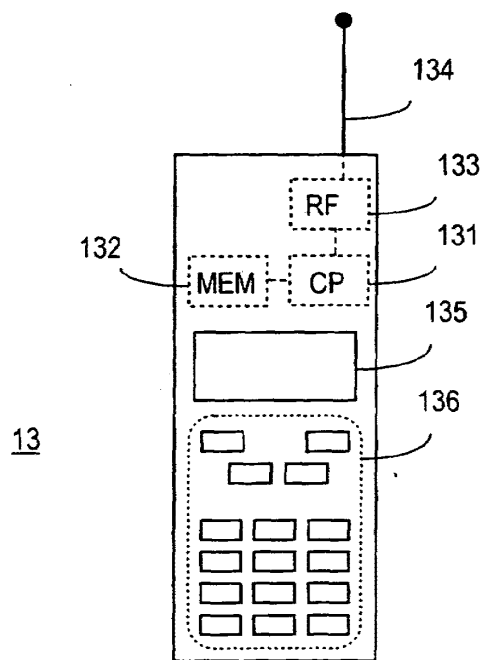


Fig. 10

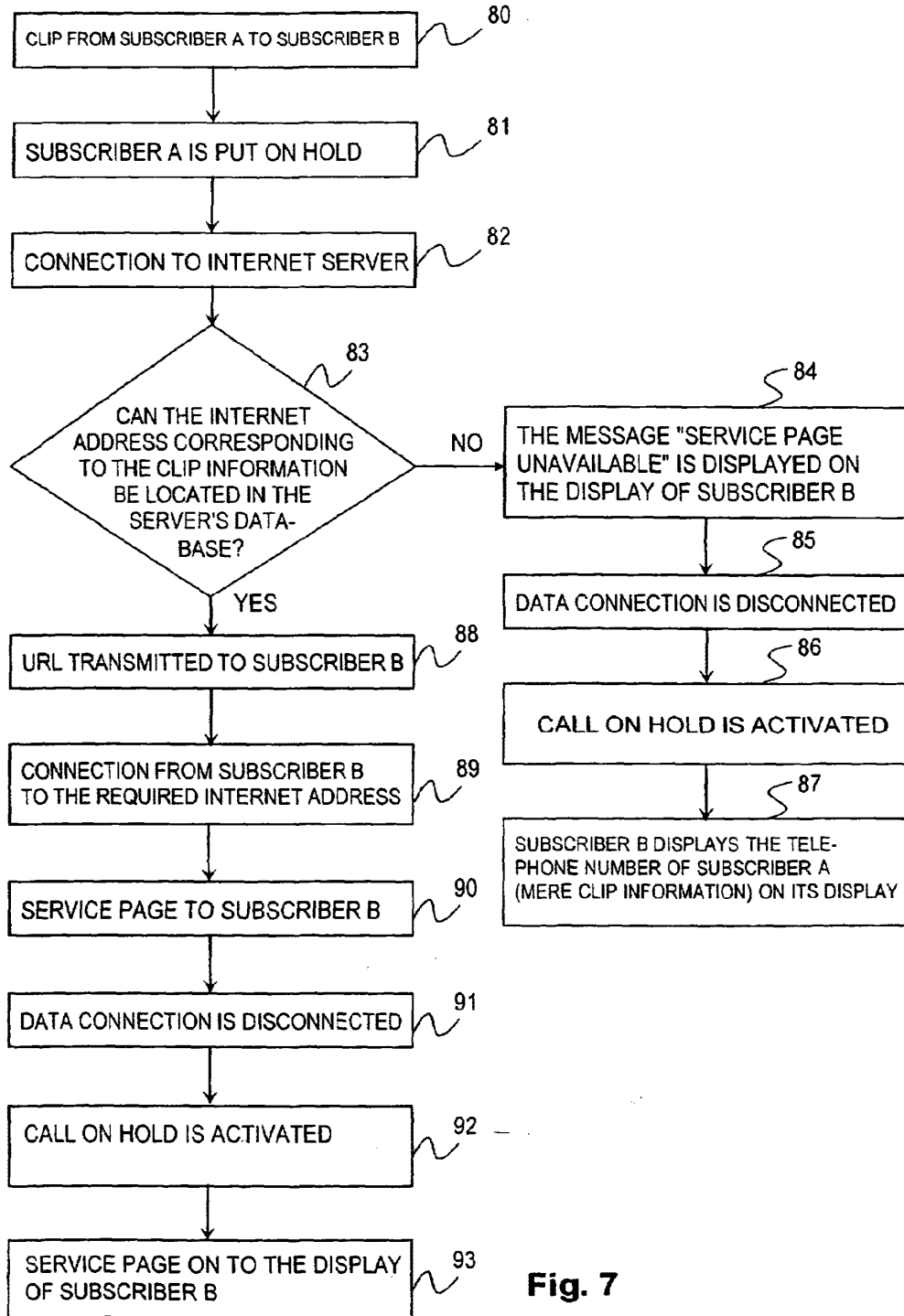


Fig. 7



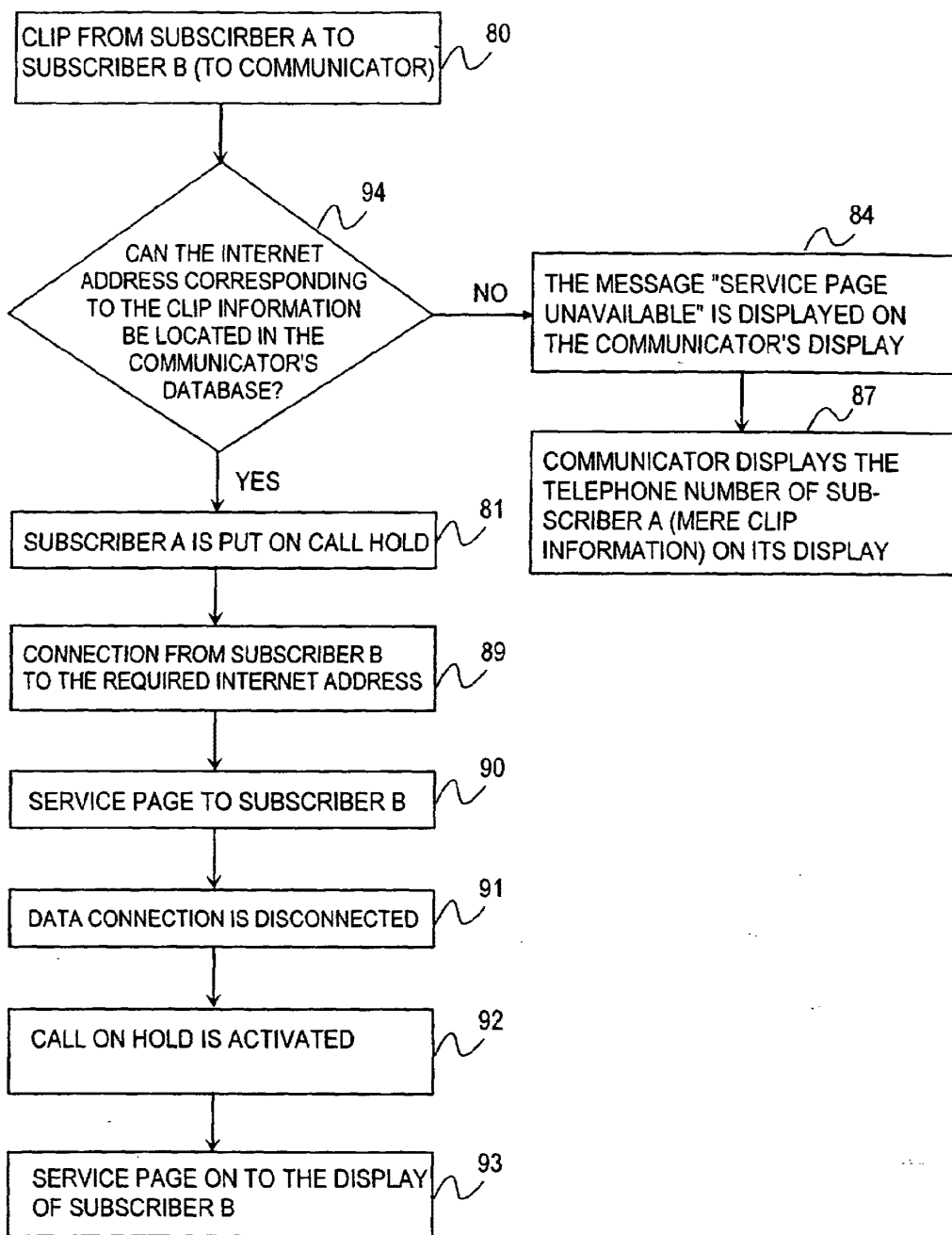


Fig. 8

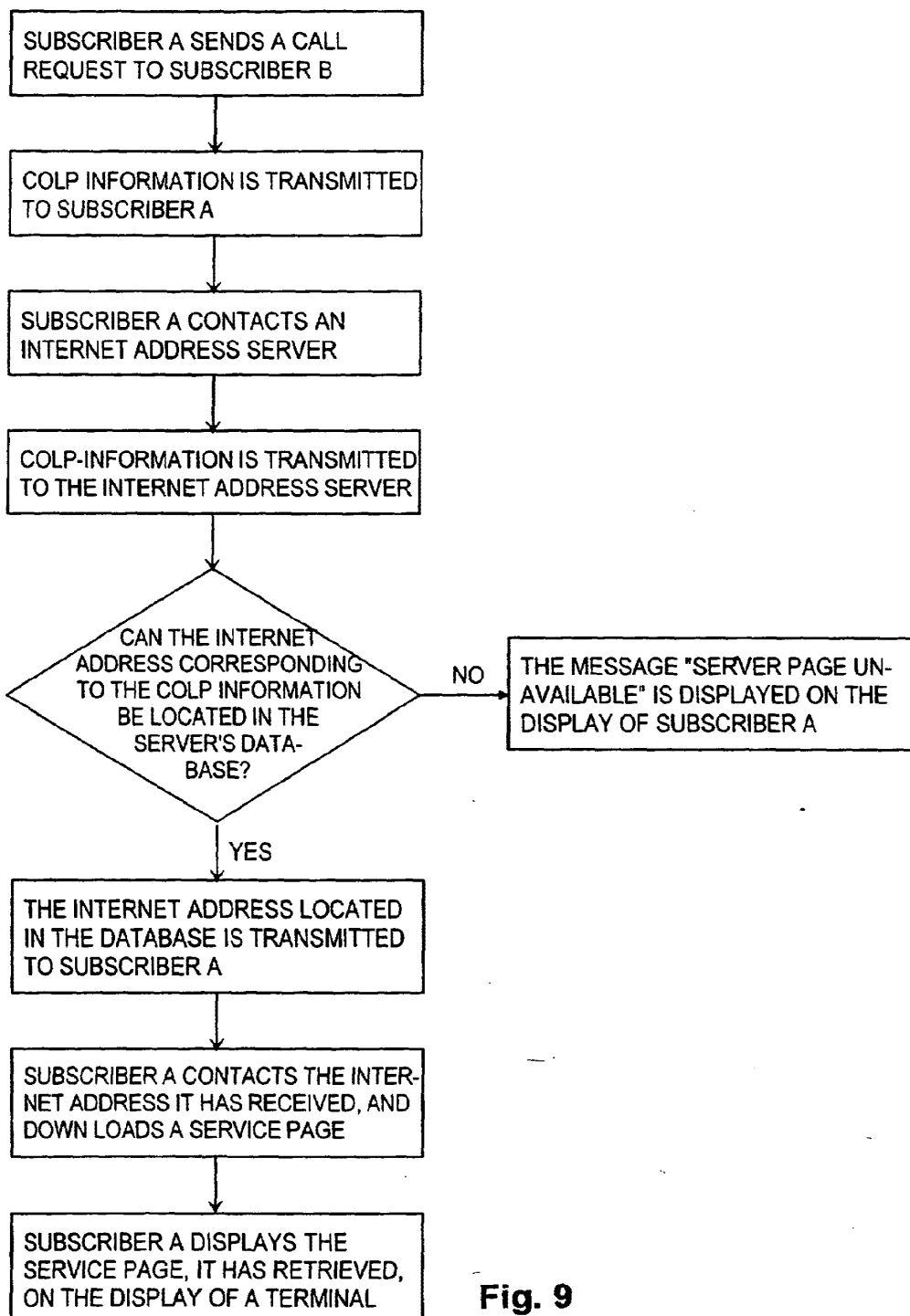


Fig. 9



(12) **EUROPEAN PATENT APPLICATION**

(43) Date of publication:  
**02.12.1998 Bulletin 1998/49**

(51) Int. Cl.<sup>6</sup>: **H04Q 7/22**, H04Q 7/32,  
H04M 3/48

(21) Application number: **98109762.9**

(22) Date of filing: **28.05.1998**

(84) Designated Contracting States:  
**AT BE CH CY DE DK ES FI FR GB GR IE IT LI LU**  
**MC NL PT SE**  
Designated Extension States:  
**AL LT LV MK RO SI**

(72) Inventors:  
• **Jyogataki, Takashi,**  
**Casio Computer Co., Ltd.**  
**Hamura-shi, Tokyo 205-8555 (JP)**  
• **Ishida, Shinjiro,**  
**Casio Computer Co., Ltd.**  
**Hamura-shi, Tokyo 205-8555 (JP)**

(30) Priority: **29.05.1997 JP 139772/97**

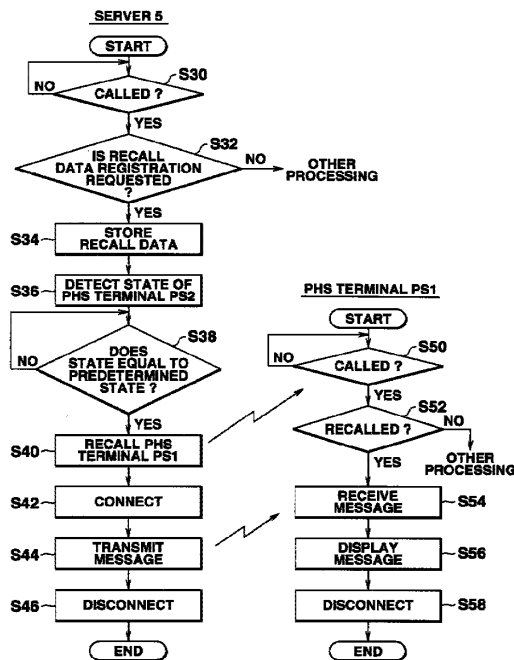
(74) Representative:  
**Grünecker, Kinkeldey,**  
**Stockmair & Schwanhäusser**  
**Anwaltssozietät**  
**Maximilianstrasse 58**  
**80538 München (DE)**

(71) Applicant:  
**Casio Computer Co., Ltd.**  
**Shibuya-ku, Tokyo 151-8543 (JP)**

(54) **Communication system**

(57) When a recall mode is selected as the operation mode of a PHS terminal (PS1), recall data is generated. The recall data specifies the other party (e.g., a PHS terminal (PS2)), a state wherein the other party enters a specific service area, and a message "the other party has arrived at Y station (in the specific service area)" which is to be received from a server (5) or the PHS terminal (PS2) when the other party (PS2) is set in the designated state. The recall data is set in the subaddress of a call set-up message and registered in the server (5) or the PHS terminal (PS2). When the PHS terminal (PS2) enters the service area of a public base station (2c) (designated state), the server (5) or the PHS terminal (PS2) transmits the message to the PHS terminal (PS1) in the recall mode (designated action). The PHS terminal (PS1) displays the transmitted message on a display device (19). The user of the PHS terminal (PS1) can know that the user of the PHS terminal (PS2) has arrived at Y station and that communication with the other party (PS2) is enabled. The state of the other portable information terminal can be recognized without requiring any operation to the other party.

**FIG.5**



EP 0 881 848 A2

## Description

The present invention relates to a communication system and, more particularly, to a communication system which frequently detects the state of each communication terminal to notify the user of a certain communication terminal of it upon detecting that a predetermined communication terminal is set in a designated state.

This application is based on Japanese Patent Application No. 9-139772, filed May 29, 1997, the content of which is incorporated herein by reference.

In recent years, a known mobile communication system is constituted by portable information terminals (e.g., a cellular telephone, a PHS terminal: Personal Handy Phone System terminal, a pager, and a PDA: Personal Digital Assistants) the users carry to transmit/receive speech data and the like to/from another terminal such as a general home telephone, and by a base station connected to a communication line such as an ISDN line to communicate with the portable information terminals and connect them to the communication line.

In this mobile communication system, a public base station connected to a public switched telephone network and set indoors or outdoors at an unspecified location, a private base station connected to a switching unit (to be referred to as a PBX hereinafter) placed in a public facility (e.g., an office), or a private master unit set in a house and functioning as the master unit of a portable information terminal is used as a base station. The public base station, private base station and private master unit are referred to a master unit hereinafter. The portable information terminal (to be also referred to as a subsidiary unit hereinafter) is connected to the communication line through the public base station, the private base station, or the private master unit to communicate with the other party.

The portable information terminal is driven by a secondary battery or the like and used as a portable unit. In the service area of the master unit, the portable information terminal is connected to the communication line through the master unit connected via a wireless channel so that the portable information terminal can communicate with another terminal. Outside the service area of the master unit, the portable information terminal is connected to the communication line through an outdoor base station connected via a wireless channel to communicate with another terminal. Information to be transmitted/received by the portable information terminal includes speech data, text data, image data, and the like.

In the conventional mobile communication system, when a user wants contact from the other party when he/she has arrived at or left a certain place or he/she is set in a predetermined state, the user depends on the memory of the other party. If the other party forgets it, no contact can be made. In this case, it is troublesome that the user must request the other party to make a

call. The above problem is not limited to the mobile communication system, but may be applied to a general communication system.

Accordingly, it is an object of the present invention to provide a communication system which can detect that a predetermined communication terminal is set in a designated state and notify the user of its certain communication terminal.

In order to achieve the above object, according to a first aspect of the present invention, there is provided a communication system which performs communication between terminals connected to a communication network via a wireless channel or a wired channel under the control of a management station for managing the communication network, wherein one of the terminals generates calling information and predetermined state information for notifying a state of the other terminal and transmits the pieces of information to the management station, and the management station stores the calling information of the terminal, which has transmitted the pieces of information, and the predetermined state information for notifying the state of the other terminal, and when the state of the other terminal equals the predetermined state information, calls the terminal on the basis of the calling information.

According to a second aspect of the present invention, there is provided a communication system which performs communication between terminals connected to a communication network via a wireless channel or a wired channel, wherein one of the terminals generates calling information and predetermined state information for notifying a state of the other terminal and transmits the pieces of information to the other terminal, and the other terminal stores the transmitted calling information and the transmitted predetermined state information, and when a self state equals the predetermined state information, calls the terminal on the basis of the stored calling information.

According to a third aspect of the present invention, the state of the other terminal may preferably be notified to the terminal using one of character data and speech data in notification based on the calling information.

According to a fourth aspect of the present invention, the transmitted calling information may preferably contain a caller number of a call set-up message, and the predetermined state information may contain data inserted in a subaddress area of the call set-up message.

According to a fifth aspect of the present invention, the predetermined state may preferably contain a state wherein the other terminal enters or leaves a predetermined area.

According to a sixth aspect of the present invention, the predetermined area preferably may be a service area of a public base station set on the communication network to connect the terminal to the communication network via a wireless channel, or an electromagnetic wave reachable range of a master unit connected to the

communication network and having a function of connecting at least a terminal which has been registered in advance to the communication network via a wireless channel.

According to a seventh aspect of the present invention, the predetermined state may preferably be a predetermined time.

According to an eighth aspect of the present invention, there is provided a communication apparatus connected to a communication network via a wireless channel or a wired channel, comprising storage means for storing other party information sent from the communication network and notification information containing a predetermined state for notifying a state of the communication apparatus itself, and means for, when a current state of the communication apparatus equals the predetermined state stored in the storage means, notifying the state on the basis of the other party information.

According to a ninth aspect of the present invention, the notification means may preferably notify the state of the communication apparatus to the other party using one of character data and speech data on the basis of the other party information.

According to a tenth aspect of the present invention, the other party information sent through the communication network may preferably contain a caller number of a call set-up message, and the predetermined state information for notifying the state of the communication apparatus itself may contain data inserted in a subaddress area of the call set-up message.

According to an eleventh aspect of the present invention, the predetermined state may preferably contain a state wherein the communication apparatus enters or leaves a predetermined area.

According to a twelfth aspect of the present invention, the predetermined area may preferably be a service area of a public base station set on the communication network to connect the communication apparatus to the communication network via a wireless channel, or an electromagnetic wave reachable range of a master unit connected to the communication network and having a function of connecting at least a communication apparatus which has been registered in advance to the communication network via a wireless channel.

According to a thirteenth aspect of the present invention, the predetermined state may preferably be a predetermined time.

According to a fourteenth aspect of the present invention, the notification information may preferably further contain a notification method, and the notification means may notify the state to the other party on the basis of the notification method.

This invention can be more fully understood from the following detailed description when taken in conjunction with the accompanying drawings, in which:

FIG. 1 is a block diagram showing the entire arrangement of a mobile communication system according to a first embodiment of the present invention;

FIG. 2 is a block diagram showing the arrangement of a PHS terminal as a portable terminal of the first embodiment;

FIG. 3 is a view for explaining a call set-up message transferred between a terminal and a base station;

FIG. 4 is a flow chart for explaining the operation of the PHS terminal upon selecting a recall mode of the first embodiment;

FIG. 5 is a flow chart for explaining the operation of a server and the operation of the PHS terminal in the recall mode which is performed when a specified communication terminal is set in a designated state in the first embodiment;

FIGS. 6A, 6B and 6C are schematic views for explaining the operation of the mobile communication system according to the first embodiment;

FIG. 7 is a flow chart for explaining the operation of a PHS terminal upon selecting a recall mode in a mobile communication system according to a second embodiment of the present invention;

FIG. 8 is a flow chart for explaining the operation of a specified communication terminal and the operation of the PHS terminal in the recall mode which is performed when the specified communication terminal is set in a designated state in the second embodiment; and

FIGS. 9A, 9B and 9C are schematic views for explaining the operation of the mobile communication system according to the second embodiment.

A preferred embodiment of a communication system according to the present invention will now be described with reference to the accompanying drawings.

#### 40 First Embodiment

FIG. 1 is a block diagram showing the entire arrangement of a system of the first embodiment in which the present invention is applied to a PHS.

Referring to FIG. 1, reference numeral 1 denotes a public switched telephone network (PSTN) or an integrated service digital network (ISDN) spread throughout the country. Such a network 1 will be referred to as a communication network hereinafter. Public base stations 2a, 2b, ... connected to the communication network 1 are set outdoors at a predetermined interval. Each public base station has a service area (electromagnetic wave reachable range: service area - in the broken line shown in FIG. 1) with a radius of several hundred meters around itself and serves as a repeater station connected to each of PHS terminals PS1, PS2, ... in the service area via a wireless channel to connect the PHS terminal to the communication network 1. A

master unit 3 is set in a house and connected to the communication network 1. The master unit 3 has a handset, dial keys, and various function keys, like a normal telephone set, and allows communication with an external telephone set. The master unit 3 communicates with the PHS terminal PS2 via a wireless channel to connect an external call to the PHS terminal PS2. In addition, the master unit 3 connects the PHS terminal PS2 to another telephone or PHS terminal on the communication network 1 in response to a connection request from the PHS terminal PS2.

Each of the PHS terminals PS1, PS2, ... is carried by a user and driven by a battery. The PHS terminal PS1 or PS2 has a liquid crystal display unit and dial keys, i.e., the same functions as those of a normal telephone set and communicates with the master unit 3 or the public base station 2a or 2b via a wireless channel so as to be connected to the communication network 1. In other words, in the service area of the master unit 3, each of the PHS terminal PS1, PS2, ... communicates with the master unit 3 via a wireless channel so as to be connected to the communication network 1. Outside the service area of the master unit 3, each of the PHS terminal PS1, PS2, ... communicates with the public base station 2a or 2b set at a close position via a wireless channel so as to be connected to the communication network 1 to communicate with another telephone set or the master unit.

The terminal (it can be not only a PHS terminal but also a master unit or a normal telephone set) of the present invention has a recall mode in which when a specific party (it can be a PHS terminal, a master unit or a normal telephone set) is set in a specific state, the user of the terminal is notified of it. To set this mode, identification information for identifying the other party, state designation information for designating the state of the other party to be notified, and notification operation designation information for designating contents to be notified in the designated state (these pieces of information will be called recall data) are set in the caller or callee subaddress to originate a call. The recall data is registered in a server 5 connected to the communication network 1. The server 5 determines whether the state of the other party equals the state designated by the state designation information contained in the recall data. If the states equal each other, an action corresponding to the notification operation designation information contained in the recall data, e.g., notification of a message representing the state of the other party is performed.

More specifically, the recall data includes a caller number for identifying the terminal where the recall mode is selected and performing recall, the other party ID for identifying the other party, state designation information for designating the state of the other party to be notified in the recall, action designation information for designating contents of the recall in the designated state, and if notification of a message is designated, the

message. A recall message has contents representing the entering/leaving state of the other party for the service area of the public base station or master unit, e.g., "Mr. X has arrived at Y station", "Mr. X has arrived at Z company", "Mr. X has left home (office)", "Mr. X has come home", "it is TT: MM", "please call Mr. X", "Is it OK to call Mr. X?".

As a designated state, the other party "enters a specific service area, i.e., area defined by a specific CS-ID", "leaves a specific service area", "enters a specific master unit area", or "leaves a specific master unit area", or "it is the designated time". A designated action is e.g., a message notification method: "transmit a message as character information", "transmit a message as speech information", "transmit a message as character information and generate a melody", or "generate a simple buzzer sound".

The server 5 controls the communication network 1 to manage communication between terminals. Especially, in the present invention, the server 5 receives recall data from the terminal set in the recall mode and determines on the basis of the location information of the other party whether the state of the other party equals a predetermined state designated by the state designation information contained in the recall data. If the states equal each other, the server 5 performs an action corresponding to the notification operation designation information contained in the recall data, e.g., notification of a message representing the state of the other party. The server 5 may be a network management station which stores various data in a database and provides various services to provide the data to the user in response to a request from the PHS terminal.

FIG. 2 is a block diagram showing the arrangement of the public base station 2a or 2b according to the first embodiment.

A transmitter/receiver 10 has a frequency conversion section and a modem. The receiver of the frequency conversion section mixes a signal received at an antenna ANT with a local oscillation signal with a predetermined frequency, which is output from a PLL synthesizer, thereby converting the received signal in the 1.9 GHz band to an IF (Intermediate Frequency) signal near the 1 MHz band. The transmitter of the frequency conversion section mixes a modulated wave based on the  $\pi/4$  shift QPSK, which is output from a modem (to be described later), with a local oscillation signal with a predetermined frequency, which is output from the PLL synthesizer, thereby converting the frequency to the 1.9 GHz band and sends it from the antenna ANT through an antenna switch. The receiver of the modem demodulates the IF signal from the frequency conversion section, separates the signal into I and Q data, and sends the data string to a communication controller 11. The transmitter of the modem generates I and Q data from data supplied from the communication controller 11, modulates it on the basis of the  $\pi/4$  shift QPSK, and sends the data to the fre-

quency conversion section of the transmitter/receiver 10.

The communication controller 11 performs frame synchronization and slot data format processing. The receiver section of the communication controller 11 extracts data of one slot from the received data supplied from the modem of the transmitter/receiver 10 at a predetermined timing and extracts a unique word (synchronization signal) from this data, thereby generating a frame synchronization signal. The receiver portion descrambles the control data portion and the speech data portion. The control data is sent to a main controller 16, and the speech data is sent to a speech processor 12. The transmitter section of the communication controller 11 adds control data and the like to speech data supplied from the speech processor 12, scrambles the data, and adds a unique word to generate transmission data of one slot. The transmission data is inserted into a predetermined slot in a frame at a predetermined timing and sent to the modem of the transmitter/receiver 10.

The speech processor 12 is constituted by a speech codec and a PCM codec. The speech codec compresses/expands digital data. The receiver section of the speech processor 12 decodes an ADPCM (Adaptive Differential Pulse Code Modulation) speech signal (4 bits  $\times$  8 KHz = 32 Kbps) supplied from the communication controller 11 to expand the speech signal which is a PCM (Pulse Code Modulation) speech signal (8 bits  $\times$  8 KHz = 64 Kbps), and outputs the signal to the PCM codec. The transmitter section of the speech processor 12 codes a PCM speech signal supplied from the PCM codec into an ADPCM speech signal to compress the PCM speech signal, and sends the signal to the communication controller 11. The above-described PCM codec performs analog/digital conversion. On the receiver section, a PCM speech signal supplied from the speech codec is converted into an analog speech signal by D/A conversion and output from a loudspeaker 13. On the transmitter section, an analog speech signal input from a microphone 14 is converted into a PCM speech signal by A/D conversion and sent to the speech codec.

A key input device 15 has number keys used to input the telephone number of the other party, an on-hook/off-hook switch, a volume switch for adjusting the speech output, a mode switch for selecting the recall mode as an operation mode, and the like. The states of the keys and switches are supplied to the main controller 16.

The main controller 16 controls the entire apparatus in accordance with a predetermined program. A storage device 17 has a storage medium 17a storing a program to be executed by the main controller 16 and various parameters. This storage medium 17a comprises a magnetic or optical storage medium or a semiconductor memory. This storing medium 17a is fixedly arranged or detachably attached in the storage device 17. The pro-

gram and parameters to be stored in the storage device 17 may be received from another device connected through a communication line and stored. Alternatively, the storage device having the storage medium may be arranged on the side of another device connected through a communication line such that the program and parameters stored in the storage medium can be downloaded through the communication line. A RAM 18 stores data generated under the control of the main controller 16 or is used as a working area.

A display device 19 has a liquid crystal display device for displaying various data such as an operation mode, a telephone number, and a communication time, and LEDs for indicating ON/OFF of a switch or the like. The display device 19 displays various data under the control of the controller 16. The display device 19 is constituted as a touch panel, and data can be input by touching a displayed icon or data with a touch pen (not shown).

FIG. 3 is a view for explaining a call set-up message. The call set-up message is information to be transferred between the caller-side terminal and the callee-side terminal (an external telephone set, a master unit, or a PHS terminal) when the terminal of the communication system originates a call or is received a call. The call set-up message has a protocol ID, a call number, a message type, a facility as another information element, a caller number, a caller subaddress, a callee number, and a callee subaddress. In the present invention, a terminal (it is not limited to a PHS terminal) which wants to know that a specific other party (it is also not limited to a PHS terminal) is set in a specific state selects the recall mode. Recall data constituted by identification information for identifying the other party, state designation information for designating a specific state, and action designation information for designating a notification to be received are generated and set in the caller or callee subaddress, and then, the terminal calls the other party. The present invention is not limited to this. As far as the recall data can be sent, it may be set in, e.g., a facility message or an optional message.

The operation of the mobile communication system according to the first embodiment will be described. This operation is executed on the basis of the program and parameters stored in the storage medium 17a in the form of program codes readable by the CPU in the main controller 16. The operations of the communication itself are the same as those of a conventional terminal, and a detailed description thereof will be omitted.

FIG. 4 is a flow chart for explaining the operation of the PHS terminal upon selecting the recall mode in the first embodiment. FIG. 5 is a flow chart for explaining the operation of the server 5 and the operation of the PHS terminal in the recall mode which is performed when the state of the other party equals a predetermined state in the first embodiment. FIGS. 6A to 6C are schematic views for explaining the operation of the entire mobile communication system according to the

first embodiment. In the following description, the PHS terminal PS1 shown in FIG. 1 is the terminal set in the recall mode, and the PHS terminal PS2 is the other party.

In step S10 in FIG. 4, the PHS terminal PS1 determines whether the recall mode is selected. If YES in step S10, the flow advances to step S12. The recall mode is selected in accordance with an instruction from the key input device 15. In step S14, the other party whose state is to be known is specified. The other party is specified by inputting a terminal ID, e.g., a telephone number or PS-ID, which has been set for each terminal in advance. In this case, the PHS terminal PS2 is specified. Not only one but also a plurality of terminals can be specified.

In step S14, a state is input. In this case, the above-described state wherein the PHS terminal PS2 "enters a specific service area corresponding to a specific CS-ID or area information, (the service area of a public base station 2c shown in FIG. 6B)" is input. It is to be noted that the Y station is located in the service area of the public base station 2c.

In step S16, an action to be executed by the server when the above state is satisfied is input. In this case, an action of "transmitting a predetermined message representing the state of the other party as character information" is input.

In step S18, this predetermined message is input. In this case, a message "Mr. X (the user of the other party PS2) has arrived at Y station" is input. If buzzer or melody sound generation is input as the action at step S16, it is not necessary to input message at step S18.

In step S20, the above information, i.e., recall data is set in the subaddress shown in FIG. 3. In step S22, the server 5 is called to transmit a call set-up message in which the recall data is set, as shown in FIG. 6A. Upon receiving a registration confirmation message, the communication channel is disconnected in step S24, and recall mode setting processing is ended.

In step S30 in FIG. 5, the server 5 determines whether it is called. If YES in step S30, it is determined in step S32 whether the call is a recall data registration request. If NO in step S32, the flow advances to other processing.

If YES in step S32, the flow advances to step S34 to store, as recall data, the caller number, the other party ID (PS2), the message, the state, and the action set in the subaddress of the call set-up message.

In step S36, the location information of the PHS terminal PS2 as the other party is acquired on the basis of the other party ID. Generally, the PHS terminal registers its location through the public base station when the PHS terminal moves to another service area or the power is turned on. Therefore, the server 5 can detect the current location of the PHS terminal.

In step S38, it is determined whether the state of the PHS terminal PS2 as the other party equals the predetermined or designated state. If NO in step S38, i.e.,

if it is determined on the basis of the location information of the PHS terminal PS2 acquired in step S36 that the PHS terminal PS2 is outside the service area of the public base station 2c, processing in step S38 is repeatedly executed until the states equal each other.

When the states equal each other, i.e., the PHS terminal PS2 enters the service area of the public base station 2c shown in FIG. 6B, the flow advances to step S40 to call the caller number (PHS terminal PS1) stored as recall data. In step S42, the communication channel connected.

In step S44, the message is transmitted to the PHS terminal PS1 in accordance with the action designated by the action designation information stored as recall data, as shown in FIG. 6C. In step S46, the communication channel is disconnected, and processing is ended.

In step S50, the PHS terminal PS1 set in the recall mode determines whether it is called. If YES in step S50, it is determined in step S52 whether the PHS terminal PS1 is recalled. If NO in step S52, the flow advances to other processing (e.g., the off-hook state is detected, and normal communication processing is performed).

If YES in step S52, the flow advances to step S54 to receive the message transmitted from the server 5, "Mr. X has arrived at Y station". In step S56, the received message is displayed on the display device 19. In step S58, processing is ended.

When a plurality of other parties are specified, location information of all other parties are acquired in step S36. In step S38, it is determined whether the state of each other party equals the designated state. If any party is set in the designated state, the PHS terminal PS1 is recalled. After recall, the flow returns to step S36 without disconnecting the line.

When only a buzzer or melody sound is to be generated without sending a message, recall notification is simply made in step S44. In step S56, the buzzer or melody sound is generated in accordance with the recall notification.

As described above, according to the first embodiment, the user of the PHS terminal PS1 in the recall mode can know that (the user of) the PHS terminal PS2 as the designated other communication party enters a predetermined service area, i.e., the user of the PHS terminal PS2 has arrived at Y station without forcing the user of the other party to perform an operation. The PHS terminal PS2 can be called on the basis of this notification, resulting in an increase in convenience.

Other embodiments of the present invention will be described next. The same reference numerals as in the first embodiment denote the same parts in the other embodiments, and a detailed description thereof will be omitted.

## Second Embodiment

A mobile communication system according to the



second embodiment has the same arrangement as that shown in FIG. 1, and a detailed description thereof will be omitted. In the second embodiment, recall data sent from the PHS terminal PS1 in the recall mode is registered not in the server 5 but directly in the other party PS2. The other party PS2 itself determines whether the self state equals a predetermined state designated by the state designation information contained in the recall data. If the state equals the designated state, an operation designated by the action designation information contained in the recall data, e.g., an operation of transmitting a message representing the self state is performed for the terminal PS1 in the recall mode. Therefore, the server 5 can be omitted.

FIG. 7 is a flow chart for explaining the operation of the PHS terminal PS1 in the recall mode according to the second embodiment. FIG. 8 is a flow chart for explaining the operation of the other party PS2 and the operation of the PHS terminal PS1 in the recall mode which is performed when the state of the other party equals the designated state in the second embodiment. FIGS. 9A to 9C are schematic views for explaining the operation of the entire mobile communication system according to the second embodiment.

In step S60 in FIG. 7, the PHS terminal PS1 determines whether the recall mode is selected. If YES in step S60, the flow advances to step S62.

In step S62, the other party (PHS terminal PS2) is specified.

In step S64, the state is input. In this case, the above-described state wherein the PHS terminal PS2 "enters a specific service area corresponding to a specific CS-ID or area information, (the service area of a public base station 2c shown in FIG. 9B)" is input.

In step S66, an action to be executed by the other party PS2 when the above state is satisfied is input. In this case, an action of "transmitting a message as character information and simultaneously generating a melody" is input.

In step S68, the message is input. In this case, a message "please call Mr. X (the user of the other party PS2 specified in step S62)" is input.

In step S70, the above information, i.e., recall data is set in the subaddress shown in FIG. 3. In step S72, the other party PS2 is called to transmit a call set-up message in which the recall data is set, as shown in FIG. 9A. Upon receiving a registration confirmation message, the communication channel is disconnected in step S74, and processing is ended.

In step S80 in FIG. 8, the PHS terminal PS2 as the other party determines whether it is called. If YES in step S80, it is determined in step S82 whether the call is a recall data registration request. If NO in step S82, the flow advances to other processing.

If YES in step S82, the flow advances to step S84 to store, as recall data, the caller number, the message, the state, and the action set in the subaddress of the call set-up message.

In step S86, the state of the own terminal is detected from the base station or master unit.

In step S88, it is determined whether the self state equals the designated state. The state designated by the PHS terminal PS1 is "the PHS terminal PS2 enters the service area of a specific CS-ID (public base station 2c)". If NO in step S88, i.e., if it is determined on the basis of the self location information acquired in step S86 that the PHS terminal PS2 itself has not entered the service area of the public base station 2c, step S88 is repeatedly executed until the states equal each other.

When the states equal each other, i.e., the PHS terminal PS2 enters the service area of the public base station 2c, as shown in FIG. 9B, the flow advances to step S90 to call the caller number stored as the recall data. In step S92, the communication channel is connected. In step S94, the message is transmitted to the PHS terminal PS1 in the recall mode in accordance with the action designated by the action designation information stored as the recall data, and at the same time, a melody generation request is transmitted. In step S96, the communication channel is disconnected, and processing is ended.

In step S100, the PHS terminal PS1 in the recall mode determines whether it is called. If YES in step S100, in step S102, it is determined that the call is a recall.

If YES in step S102, the flow advances to step S104 to receive the message transmitted from the PHS terminal PS2, i.e., "please call Mr. X". In step S106, the received message is displayed on the display device 19, and a melody is generated from the loudspeaker 13. In step S108, processing is ended.

As described above, according to the second embodiment as well, the user of the PHS terminal PS1 in the recall mode can know that (the user of) the PHS terminal PS2 as the specified party enters a predetermined service area without forcing the user of the other party to perform an operation. The PHS terminal PS2 can be called on the basis of this notification, resulting in an increase in convenience.

As has been described above, according to the present invention, the terminal connected to the communication network via a wireless channel or a wired channel generates the calling information of the terminal and predetermined state information for notifying the state of the other terminal and transmits these pieces of information to a management station. Upon receiving the pieces of information, the management station calls the terminal on the basis of the calling information when the state of the other terminal equals the state designated by the predetermined state information. The state of the other terminal can be detected without requiring any operation to the other party.

The terminal connected to the communication network via a wireless channel or a wired channel generates the calling information of the terminal and predetermined state information for notifying the state of

the other terminal and transmits these pieces of information to the other terminal. Upon receiving the pieces of information, the other terminal calls the terminal on the basis of the calling information when the state of the other terminal equals the predetermined state designated by the predetermined state information. The state of the other portable information terminal can be detected without requiring any operation to the other party.

In addition, since the state of the other terminal is notified using character or speech data, the state of the other portable information terminal can be visually or auditorily known without requiring any operation to the other party.

The transmitted calling information contains the caller number of a call set-up message. The predetermined state information is data inserted in the subaddress area of the call set-up message. Therefore, with a simple arrangement using an existing system, the state of the other portable information terminal can be detected without requiring any operation to the other party.

The predetermined state means that the other terminal enters or leaves a predetermined area. Therefore, the state wherein the other terminal enters or leaves the predetermined area can be detected without requiring any operation to the other party.

The predetermined area is the service area of a public base station set on the communication network to connect the terminal to the communication network via a wireless channel or the electromagnetic wave reachable range of a master unit connected to the communication network and having a function of connecting the terminal which has been registered in advance to the communication network via a wireless channel. Therefore, the state wherein the other terminal enters or leaves the service area of a predetermined public base station or the electromagnetic wave reachable range of the master unit can be detected without requiring any operation to the other party.

When the predetermined state is a predetermined time, the terminal is called by the management station or the other terminal at that time. Therefore, the predetermined time can be detected without requiring any operation to the other party.

The communication apparatus connected to the communication line stores other party information sent through the communication line and notification information containing a predetermined state for notifying the state of the communication apparatus itself. When the state of the communication apparatus equals the stored predetermined state, this state is notified to the other party. Therefore, the state of the communication apparatus can be notified in response to a request from the other party.

In addition, since the state of the communication apparatus is notified using character or speech data, the state of the communication apparatus can be visu-

ally or auditorily notified in response to a request from the other party.

The other party information transmitted through the communication network contains the caller number of a call set-up message. The predetermined state for notifying the state of the communication apparatus itself is data inserted in the subaddress area of the call set-up message. Therefore, the state of the communication apparatus can be easily notified in response to a request from the other party.

The predetermined state means that the communication apparatus enters or leaves a predetermined area. Therefore, the state wherein the communication apparatus enters or leaves the predetermined area can be notified in response to a request from the other party.

The predetermined area is the service area of a public base station set on the communication network to connect the communication apparatus to the communication network via a wireless channel or the electromagnetic wave reachable range of a master unit connected to the communication network and having a function of connecting the communication apparatus which has been registered in advance to the communication network via a wireless channel. Therefore, the state wherein the communication apparatus enters or leaves the service area or the area of the master unit can be notified in response to a request from the other party.

When the predetermined state is a predetermined time, the communication apparatus can notify the predetermined time in response to a request from the other party.

The notification information further contains a notification method. Notification is made on the basis of this notification method. The notification method can be changed in accordance with a request from the other party.

Additional advantages and modifications will readily occur to those skilled in the art. Therefore, the present invention in its broader aspects is not limited to the specific details, representative devices, and illustrated examples shown and described herein. Accordingly, various modifications may be made without departing from the spirit or scope of the general inventive concept as defined by the appended claims and their equivalents. In the above embodiments, the other party enters a predetermined service area. However, a state wherein the other party leaves a predetermined service area or leaves (goes out from) the service area of the master unit 3 can also be detected.

In the above embodiments, a PHS terminal is set in the recall mode. However, the terminal is not limited to this. The above embodiments can also be realized with a conventional wired telephone having message input and display functions.

### Claims

1. A communication system which performs communication between terminals (PS1, PS2) connected to a communication network (1) under the control of a management station (5) for managing said communication network, characterized in that
- each of said terminals (PS1) transmits recall data to the management station (5) when a recall mode is selected, the recall data including information to be notified of a state in which a predetermined other terminal equals to a predetermined state; and  
said management station (5) stores the recall data and informs the terminal (PS1) in which the recall mode is selected of a state in which the predetermined other terminal (PS2) equals to the predetermined state.
2. A communication system which performs communication between terminals (PS1, PS2) connected to a communication network (1), characterized in that
- each of said terminals (PS1) transmits recall data to a predetermined other terminal when a recall mode is selected, the recall data including information to be notified of a state in which the predetermined other terminal equals to a predetermined state; and  
the predetermined other terminal (PS2) stores the recall data and informs the terminal (PS1) in which the recall mode is selected of a state in which the predetermined other terminal (PS2) equals to the predetermined state.
3. A system according to claim 1 or 2, characterized in that the state of the other terminal (PS2) is notified to said terminal (PS1) set in the recall mode using one of character data and speech data.
4. A system according to claim 1 or 2, characterized in that the transmitted calling information contains a caller number of a call set-up message, and the predetermined state information contains data inserted in a subaddress area of the call set-up message.
5. A system according to claim 1 or 2, characterized in that the predetermined state means a state wherein the other terminal enters or leaves a predetermined area.
6. A system according to claim 1 or 2, characterized in that the predetermined state means a state wherein the other terminal enters or leaves a predetermined area as one of a service area of a public base station set on said communication network to connect said terminal to said communication network via a wireless channel and an electromagnetic wave reachable range of a master unit connected to said communication network and having a function of connecting at least a terminal which has been registered in advance to said communication network.
7. A system according to claim 1 or 2, characterized in that the predetermined state is a predetermined time.
8. A communication apparatus connected to a communication network (1), characterized by comprising:
- storage means (S84) for storing recall data including other party information sent from said communication network and state information for notifying a predetermined state of said communication apparatus itself; and  
means (S88, S90, S94) for, when a current state of said communication apparatus equals the predetermined state corresponding to the state information stored in said storage means, notifying the state to the other party designated by the other party information.
9. An apparatus according to claim 8, characterized in that said notification means notifies the state of said communication apparatus to the other party using one of character data and speech data.
10. An apparatus according to claim 8, characterized in that the other party information sent through said communication network contains a caller number of a call set-up message, and the state information for notifying the state of said communication apparatus itself contains data inserted in a subaddress area of the call set-up message.
11. An apparatus according to claim 8, characterized in that the predetermined state means a state wherein said communication apparatus enters or leaves a predetermined area.
12. An apparatus according to claim 11, characterized in that the predetermined area is one of a service area of a public base station set on said communication network to connect said communication apparatus to said communication network via a wireless channel and an electromagnetic wave reachable range of a master unit connected to said communication network and having a function of connecting at least a communication apparatus which has been registered in advance to said communication network via a wireless channel.

13. An apparatus according to claim 8, characterized in that the predetermined state is a predetermined time.

sage which contains a protocol identifier, a call number, a message type, a facility, a caller number, a caller subaddress, a callee number and a callee subaddress.

14. An apparatus according to claim 8, characterized in that the notification information further contains a notification method, and said notification means notifies the state to the other party on the basis of the notification method.

5

10

15. A method for controlling a communication system comprising terminals connected to a communication network and a management station for managing said communication network, characterized by comprising the following steps of:

15

transmitting (S22, S72) recall data to the management station or a predetermined other party from a terminal in which a recall mode is selected, the recall data including information to be notified of a state in which the predetermined other terminal equals to a predetermined state;

20

storing (S34, S84) the recall data by the management station or the predetermined other party; and

25

informing (S44, S94) the terminal in which the recall mode is selected of a state in which the predetermined other terminal equals to the predetermined state.

30

16. A method according to claim 15, characterized in that said terminal in which the recall mode is selected transmits the recall data which includes identification information for identifying the other terminal, state designation information for designating the state of the other terminal to be notified, and action designation information for designating contents of notification.

35

40

17. A method according to claim 16, characterized in that said action designation information includes a message display for notifying the state of the other terminal.

45

18. A method according to claim 16, characterized in that said action designation information includes a speech information for notifying the state of the other terminal.

50

19. A method according to claim 16, characterized in that said action designation information includes an alarm tone generation.

20. A method according to claim 15, characterized in that said terminal in which the recall mode is selected transmits the recall data with being inserted in a subaddress area of a call set-up mes-

55

FIG.1

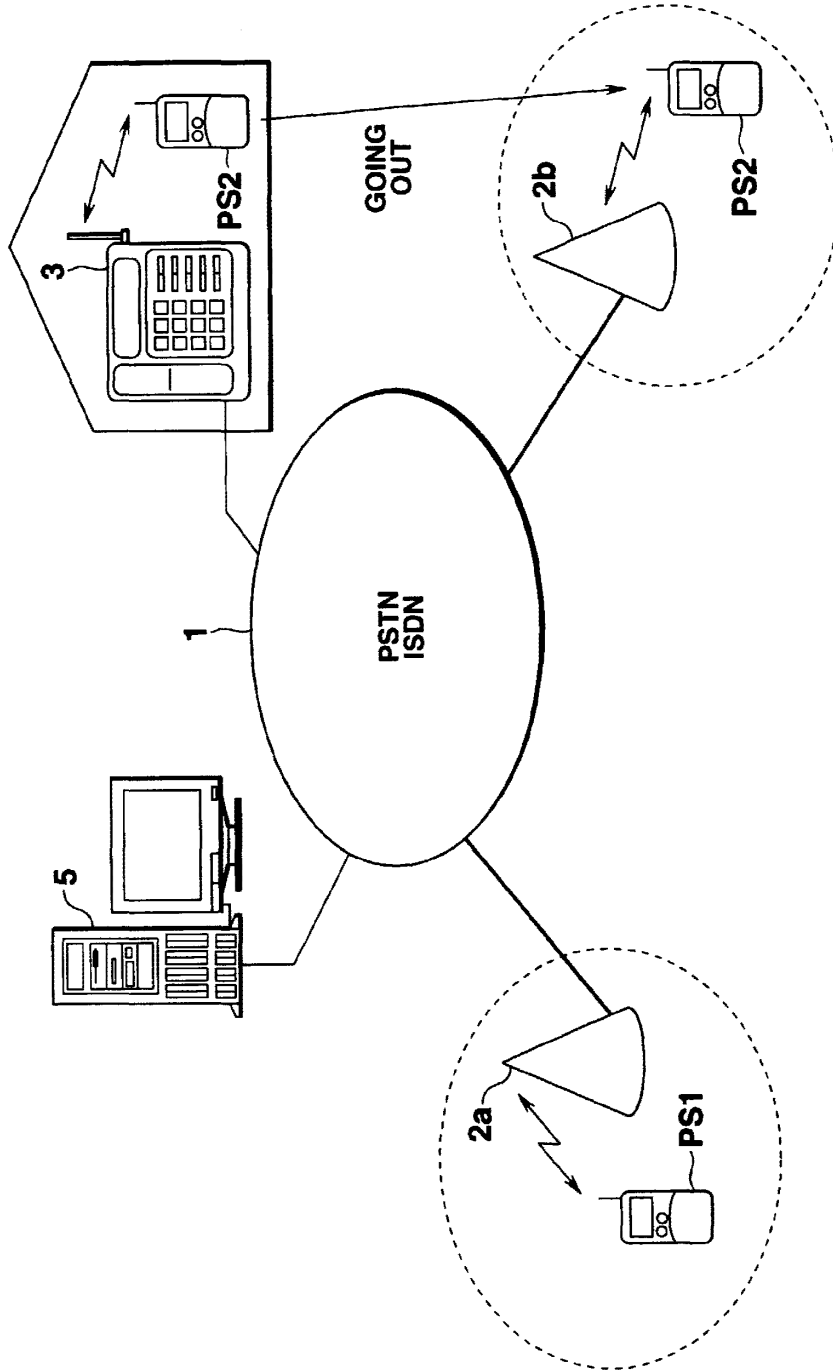
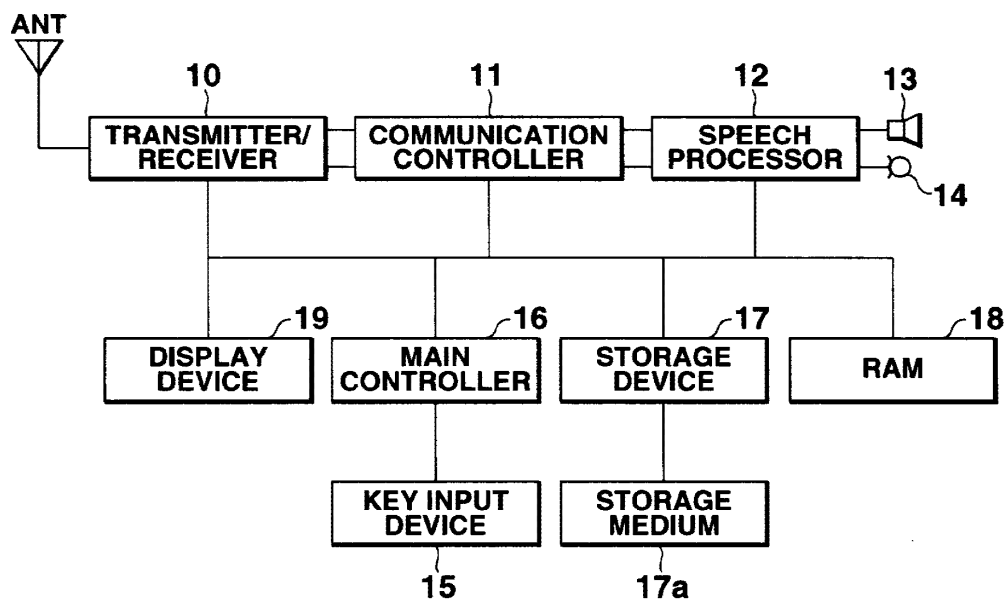


FIG.2



**FIG.3**

<b>PROTOCOL ID</b>	<b>CALL NUMBER</b>	<b>MESSAGE TYPE</b>	<b>FACILITY</b>	<b>CALLER NUMBER</b>	<b>CALLER SUBADDRESS</b>	<b>CALLEE NUMBER</b>	<b>CALLEE SUBADDRESS</b>
------------------------	------------------------	-------------------------	-----------------	--------------------------	------------------------------	--------------------------	------------------------------

13

EP 0 881 848 A2

**FIG.4**

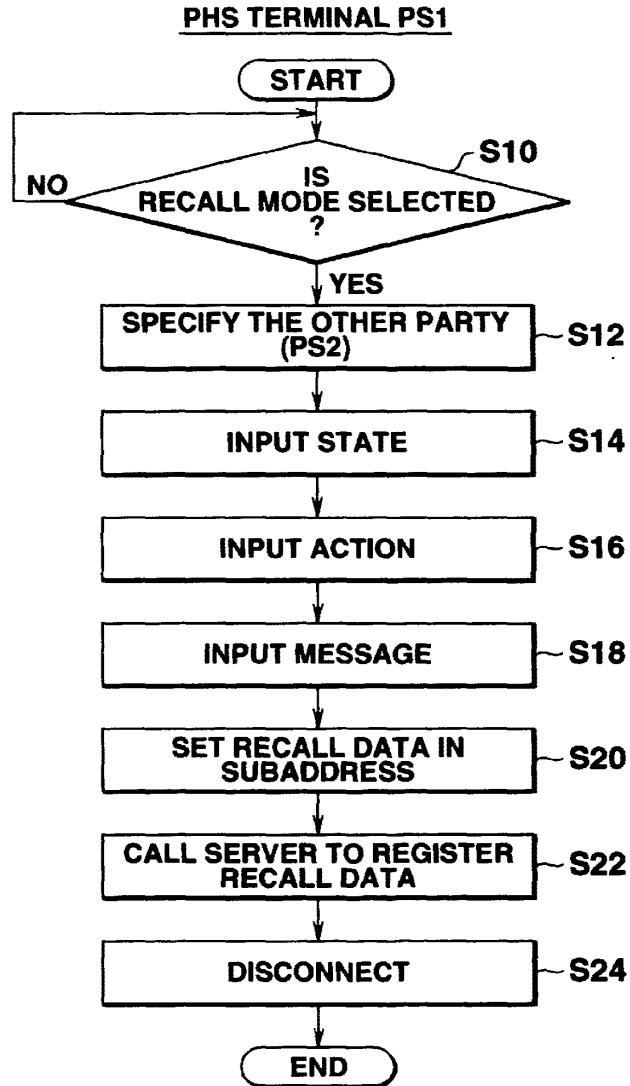
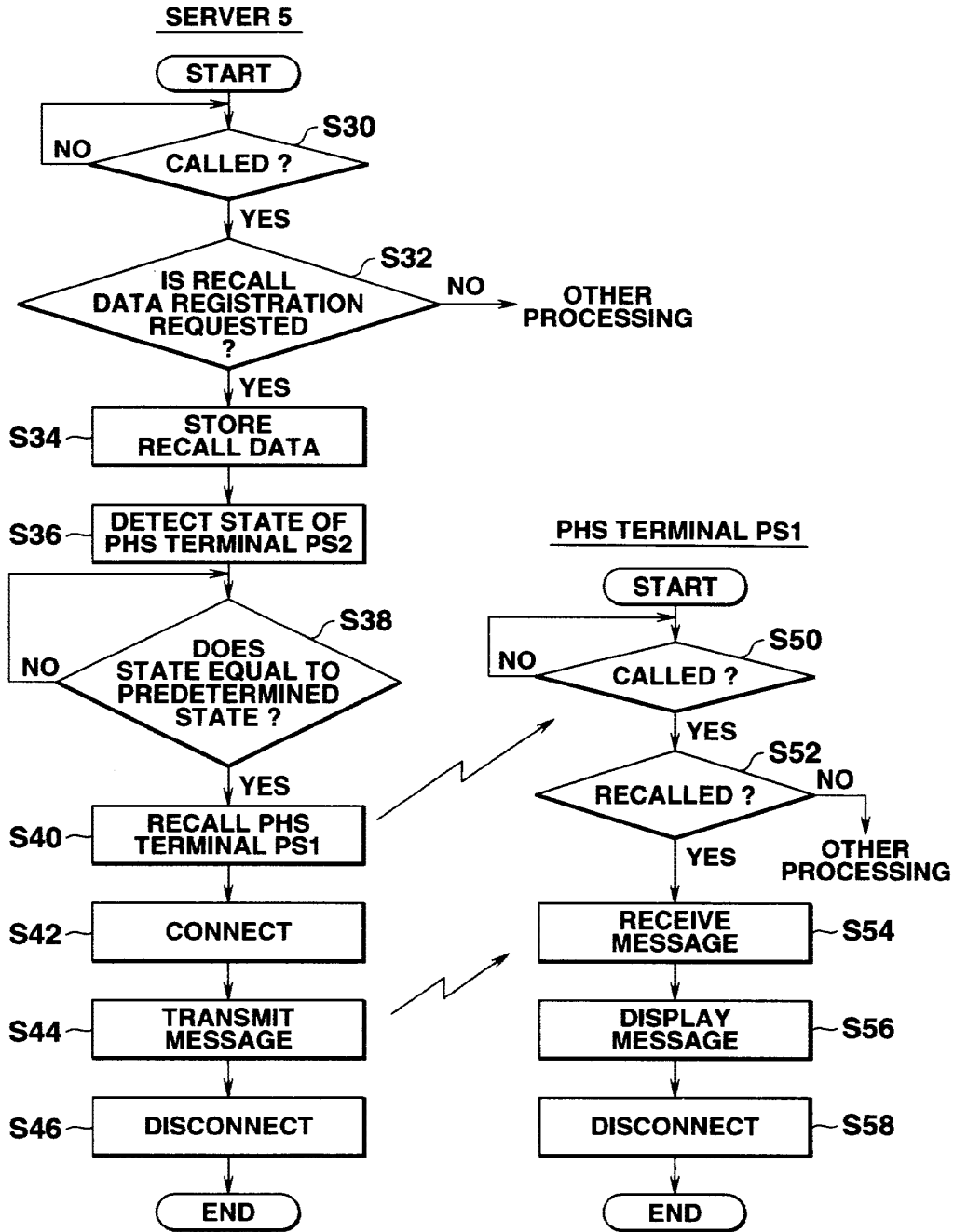
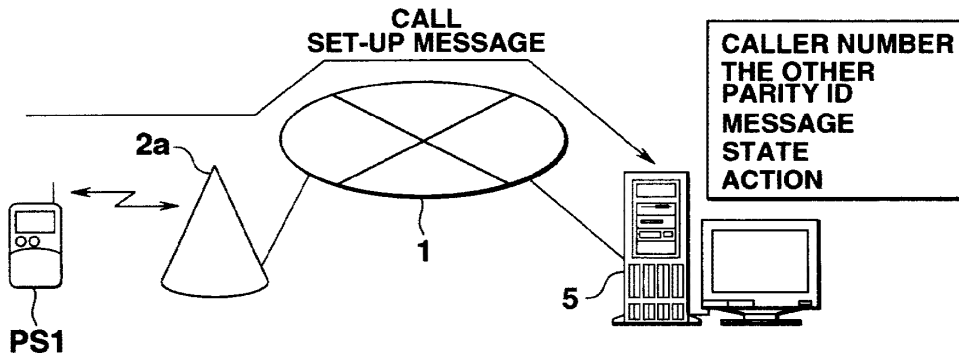




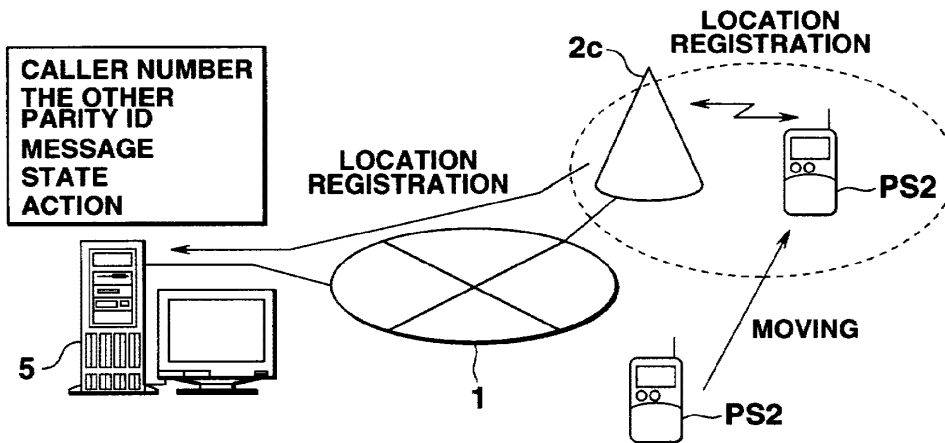
FIG.5



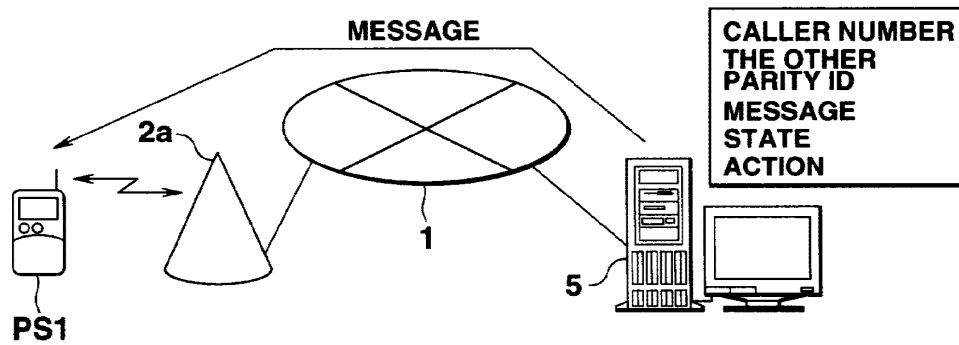
**FIG.6A**



**FIG.6B**



**FIG.6C**



**FIG.7**

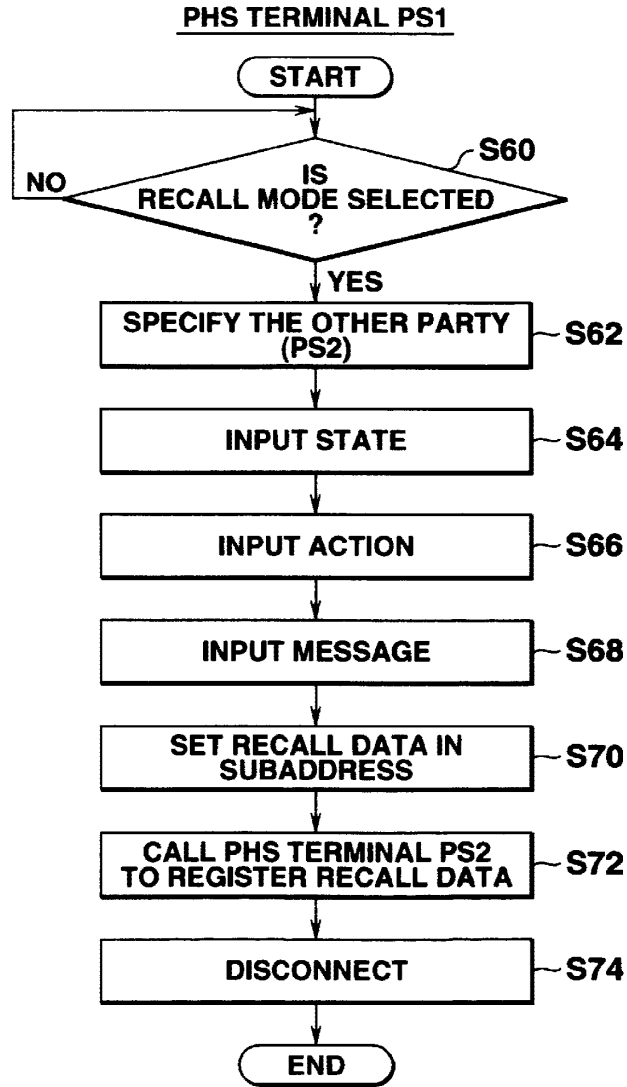
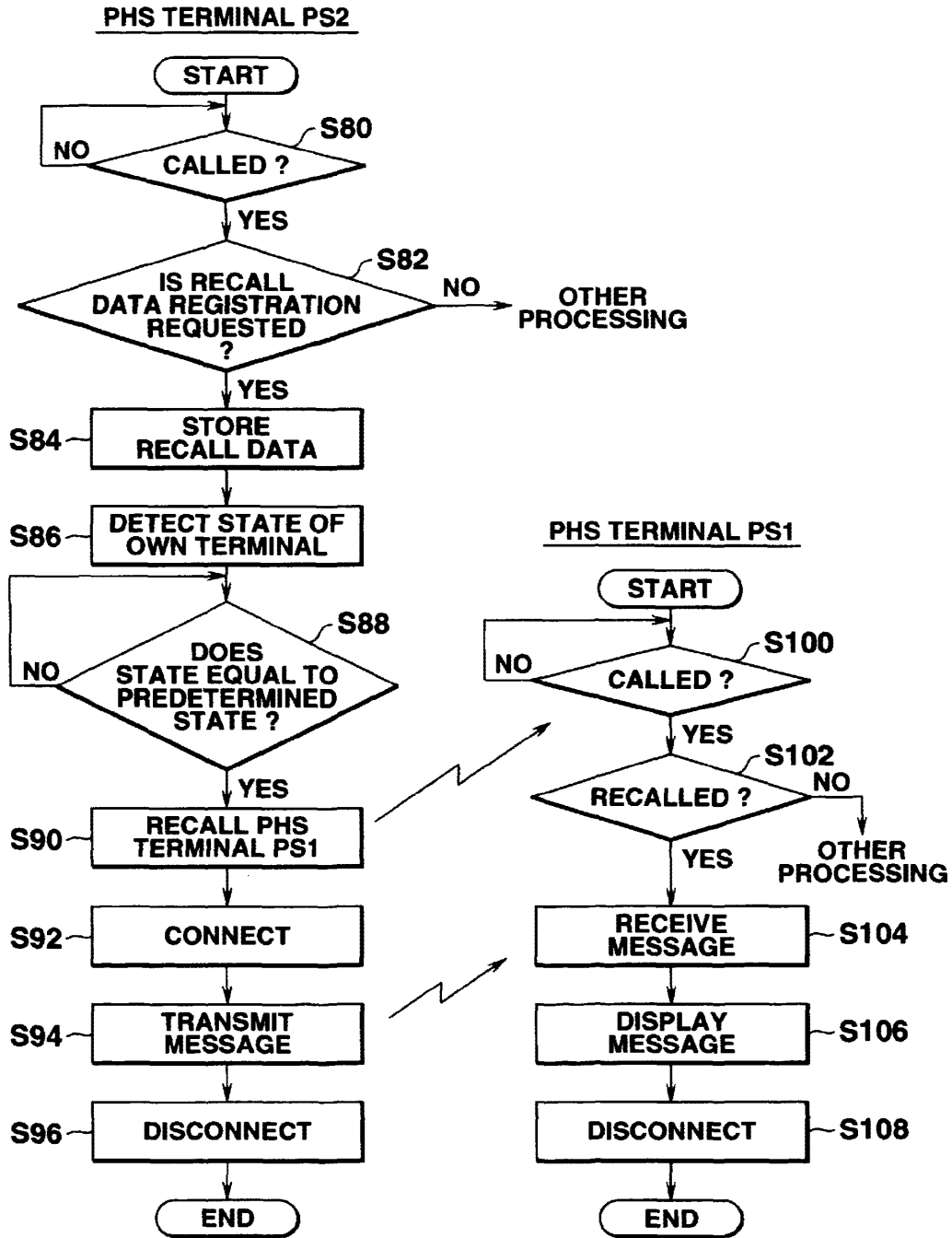
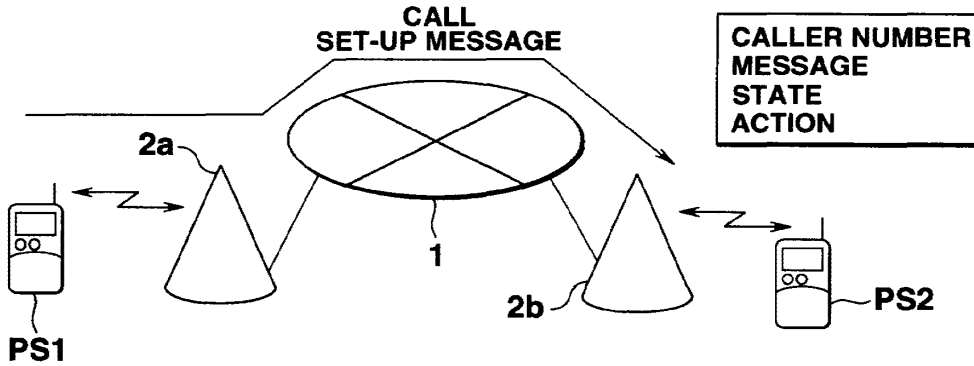


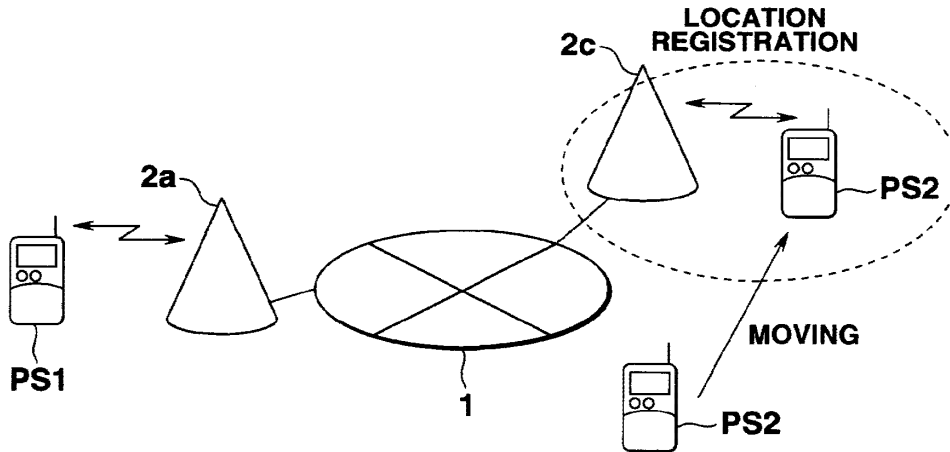
FIG.8



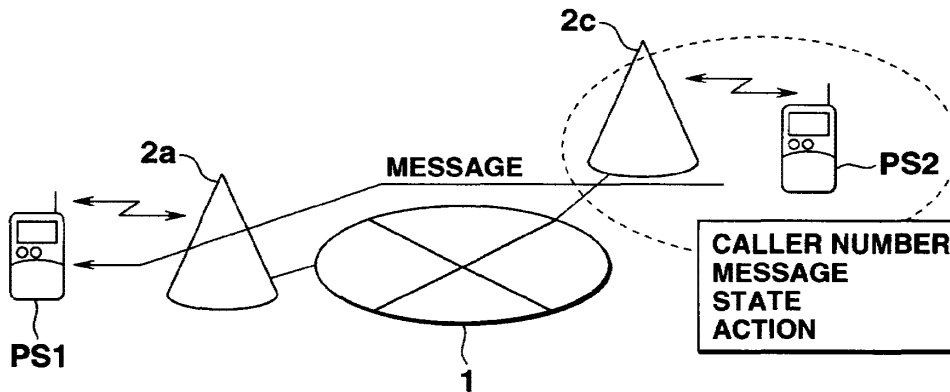
**FIG.9A**



**FIG.9B**



**FIG.9C**



(19)



Europäisches Patentamt  
European Patent Office  
Office européen des brevets



(11)

**EP 0 918 423 B1**

(12)

**EUROPÄISCHE PATENTSCHRIFT**

(45) Veröffentlichungstag und Bekanntmachung des Hinweises auf die Patenterteilung:  
**10.03.2004 Patentblatt 2004/11**

(51) Int Cl.7: **H04L 29/06**

(21) Anmeldenummer: **98118755.2**

(22) Anmeldetag: **05.10.1998**

(54) **Mobiles Telefon für Internet-Anwendungen**

Mobile phone for Internet applications

Téléphone mobile pour applications Internet

(84) Benannte Vertragsstaaten:  
**AT DE FR GB IT NL SE**

(30) Priorität: **15.10.1997 DE 19745539**

(43) Veröffentlichungstag der Anmeldung:  
**26.05.1999 Patentblatt 1999/21**

(73) Patentinhaber: **Nokia Corporation**  
**02150 Espoo (FI)**

(72) Erfinder: **Theimer, Wolfgang**  
**44795 Bochum (DE)**

(74) Vertreter:  
**TER MEER STEINMEISTER & PARTNER GbR**  
**Patentanwälte,**  
**Mauerkircherstrasse 45**  
**81679 München (DE)**

(56) Entgegenhaltungen:  
**WO-A-97/26750**

- **KENNEDY P: "MobileWeb/sup TM/ changing the face of mobile networking through universal wireless connectivity" IEEE TECHNICAL APPLICATIONS CONFERENCE. NORTHCON/96. CONFERENCE RECORD (CAT. NO.96CH35928), IEEE TECHNICAL APPLICATIONS CONFERENCE. NORTHCON/96. CONFERENCE RECORD, SEATTLE, WA, USA, 4-6 NOV. 1996, Seiten 89-94, XP002128907 1996, New York, NY, USA, IEEE, USA ISBN: 0-7803-3277-6**
- **"Nokia 9000 Technical Specifications" , [Online] 21. Juni 1997 (1997-06-21), Seiten 1-2, XP002128908 Retrieved from the Internet: &lt;URL:http://www.midnet.ie/cellworld/specif i.html&gt; [retrieved on 2000-01-27]**

**EP 0 918 423 B1**

Anmerkung: Innerhalb von neun Monaten nach der Bekanntmachung des Hinweises auf die Erteilung des europäischen Patents kann jedermann beim Europäischen Patentamt gegen das erteilte europäische Patent Einspruch einlegen. Der Einspruch ist schriftlich einzureichen und zu begründen. Er gilt erst als eingelegt, wenn die Einspruchsgebühr entrichtet worden ist. (Art. 99(1) Europäisches Patentübereinkommen).

## Beschreibung

**[0001]** Die Erfindung betrifft ein mobiles Telefon gemäß dem Oberbegriff des Patentanspruchs 1, das insbesondere in einem Kommunikationssystem zur Überwachung und/oder Führung eines Fahrzeugs oder zur medizinischen Überwachung eines Patienten verwendet werden kann.

**[0002]** Kommunikationssysteme zum Beispiel zur Überwachung und/oder Führung eines Fahrzeugs sind allgemein bekannt. So gibt es etwa bereits Fahrzeuge (Internet-Autos), die an das Internet angekoppelt sind, was einem Fahrer des Fahrzeugs eine Reihe technisch interessanter Möglichkeiten eröffnet. Nachteil derartiger Fahrzeuge ist allerdings, daß im Innern des Fahrzeugs ein als eigenständiger Web-Server programmierter internetfähiger Fahrzeugcomputer vorhanden sein muß, der über ein schnurloses mobiles Telefon mit dem Internet verbunden ist. Derartige internetfähige Fahrzeugcomputer brauchen jedoch zum einen sehr viel Platz und sind zum anderen relativ teuer.

**[0003]** Ein gattungsgemäßes mobiles Telefon, das nur einen Web-Browser enthält, ist aus "Nokia 9000 Technical Specifications", [Online] 21. Juni 1997 (1997-06-21), Seiten 1 - 2, XP002128908 Retrieved from the Internet: <URL: <http://www.midnet.ie/cell-world/specifi.html>> bekannt.

**[0004]** Work stations for client-server-Anwendungen sind bereits bekannt durch: Petri Pöyhönen "GSM PLMN makes a mobile office viable" Nokia Cellular Systems Speakers' Papers. 6th World Telecommunications Forum, Part 2. Technical Symposium. Integration, Interoperation and Interconnection: The Way To Global Services, Geneva, Switzerland 10-15 Oct. 1991 page 375-378. Vol 2. XP-0010332560. Eine derartige aus PC und Mobiltelefon aufgebaute Workstation dient als Datenbasis-Endgerät zur Eingabe von Anfragen sowie zum Empfang von Antworten von einem Datenbasis-Server, den sich die Workstation mit anderen Workstations teilt. Die Workstation hat hier also Browser-Funktion.

**[0005]** Der Artikel von B.N. Schilit et al., "TeleWeb: Lossely connected access to the World Wide Web", Computer Networks and ISDN Systems 28 (1996) Seiten 1431-1444, Elsevier Science B.V., befasst sich mit einem System, das jemandem ermöglicht jederzeit und überall im WEB zu browsen, egal ob er mit einem Netzwerk verbunden ist oder nicht.

**[0006]** Insbesondere befassen sich B.N. Schilit et al. mit dem verbesserten Internetzugang für ein Laptop, also für einen beweglichen Computer, und beschreiben in einem Szenario, wie mit Hilfe des TeleWeb ein Laptop überall dort mit dem World Wide Web verbindbar ist, wo ein wie auch immer gearteter Telefonanschluss vorhanden ist, also beispielsweise am Flughafen, im Flugzeug, im Hotel, usw.

**[0007]** Um die Möglichkeiten des Internetzugangs mittels eines Browsers im tragbaren Computer zu ver-

bessern ist im tragbaren Computer ein sogenannter TeleWeb Daemon vorgesehen, der als "caching proxy" dient. Dieser caching proxy empfängt Anfragen von dem Browser im tragbaren Computer oder Laptop oder leitet diese entweder an das Netzwerk für einen Zugriff zum World Wide Web weiter oder, in dem Fall, dass die gewünschte Internetseite bereits im TeleWeb cach gespeichert ist, wird diese vom caching proxy selbst dem Browser zur Verfügung gestellt.

**[0008]** Aufgabe der Erfindung ist es, ein mobiles Telefon der eingangs genannten Art so weiterzubilden, daß mit ihm eine einfachere Kommunikation im Internet möglich ist.

**[0009]** Die Lösung der gestellten Aufgabe ist dem kennzeichnenden Teil des Patentanspruchs 1 zu entnehmen. Vorteilhafte Ausgestaltungen sind in den Unteransprüchen dargestellt.

**[0010]** Das mobile Telefon enthält mindestens einen WEB-Server. Ein WEB-Server ist dabei ein Software-Paket, das bestimmte Informationen über eine Schnittstelle zum Internet zur Verfügung stellt, die auf Anforderung von anderen, mit dem Internet verbundenen Einrichtungen abgefragt werden kann. Dadurch daß der WEB-Server im mobilen Telefon enthalten ist, wird auf einfache Weise ein lokal unabhängiger WEB-Server gebildet, der sich zu jeder Zeit beim Benutzer des mobilen Telefons befindet, falls dieser das Telefon mit sich führt.

**[0011]** Alternativ kann der WEB-Server die Information auch über eine Schnittstelle an ein lokales Netzwerk (LAN) oder ein anderes Netzwerk liefern. Desweiteren ist es denkbar, daß mehrere WEB-Server in einem mobilen Telefon enthalten sind, wobei zum Beispiel ein WEB-Server mit dem Internet verbunden ist, während ein anderer WEB-Server etwa mit einem lokalen Netzwerk verbunden sein kann. Dabei ist es auch denkbar, daß die einzelnen im mobilen Telefon enthaltenen WEB-Server untereinander gekoppelt sind.

**[0012]** Der Erfindung nach ist der mindestens eine WEB-Server in der Mikroprogrammsteuereinheit (MCU) des mobilen Telefons enthalten. Durch die Implementierung des WEB-Servers in der in einem mobilen Telefon bereits vorhandenen Mikroprogrammsteuereinheit braucht das mobile Telefon nicht mit zusätzlichen Komponenten erweitert zu werden.

**[0013]** Nach einer bevorzugten Weiterbildung der Erfindung ist der mindestens eine WEB-Server mit mindestens einem weiteren Server koppelbar. Dadurch kann auf jedem Server inhaltlich zusammengehörige Information enthalten sein, was einen schnellen Zugriff auf die entsprechende Information, zum Beispiel zur Aktualisierung, wesentlich vereinfacht. Dabei braucht der weitere Server lediglich bei Bedarf mit dem WEB-Server gekoppelt zu sein, wobei alternativ auch eine ständige Verbindung denkbar ist.

**[0014]** Nach einer weiteren Ausgestaltung der Erfindung ist der weitere Server im mobilen Telefon enthalten, wodurch er ebenfalls lokal unabhängig wird. Es kann sich bei dem weiteren Server aber auch um einen

außerhalb des mobilen Telefons angeordneten handeln.

**[0015]** Ferner ist es möglich, daß auch mehrere Server im mobilen Telefon enthalten sind oder mehrere externe Server über eine Luftschnittstelle mit dem mobilen Telefon verbunden sind. Falls mehrere Server vorhanden sind, können diese zum Beispiel untereinander ständig oder bei Bedarf miteinander gekoppelt sein. Mit Hilfe eines externen Servers kann zum Beispiel spezielle Information von einem Service-Provider über eine Luftschnittstelle an den im mobilen Telefon enthaltenen WEB-Server übertragen werden. Dies ist dann von Vorteil, wenn die Information so umfangreich ist, daß ein Speichern dieser Information auf dem lokal unabhängigen WEB-Server aus Platzgründen nicht möglich ist.

**[0016]** Der Unterschied zwischen dem im mobilen Telefon enthaltenen WEB-Server und den im mobilen Telefon enthaltenen Servern liegt darin, daß lediglich der WEB-Server zum Beispiel über eine Luftschnittstelle mit einem Netzwerk (Internet, LAN) koppelbar ist.

**[0017]** Nach einer anderen Ausgestaltung der Erfindung ist der im mobilen Telefon enthaltene WEB-Server mit mindestens einem weiteren Client koppelbar. Ein Client ist ein Software-Paket, das von einem Server, also einem zweiten Software-Paket, Information erfragt. Dabei ist der mindestens eine weitere Client im mobilen Telefon enthalten.

**[0018]** Denkbar ist auch, daß der im mobilen Telefon enthaltene WEB-Server mit einem externen Client koppelbar ist, der zum Beispiel als autorisierter Browser ausgebildet ist und über die Luftschnittstelle Information vom WEB-Server abrufen kann.

**[0019]** Nach einer bevorzugten Ausführungsform der Erfindung ist der im mobilen Telefon enthaltene WEB-Server selbst als Client betreibbar. Dadurch kann der WEB-Server zum Beispiel von einem externen Server (Service-Provider) Information abrufen, wobei für den Zugriff auf den Service-Provider zum Beispiel der als WEB-Browser ausgebildete und im mobilen Telefon enthaltene Client verwendet werden kann. Ferner wird der WEB-Server als Client betrieben, wenn er Information von einem oder mehreren Servern, die im mobilen Telefon enthalten oder aber extern ausgebildet sein können, abrufen.

**[0020]** Gemäß einer vorteilhaften Weiterbildung des erfindungsgemäßen mobilen Telefons wird dieses in einem Kommunikationssystem zur Überwachung und/oder Führung eines Fahrzeugs verwendet. Somit kann auf relativ einfache Weise eine Kontrolle und Steuerung des Fahrzeugs durch den Fahrer oder eine externe Leitstelle erfolgen.

**[0021]** Nach einer anderen bevorzugten Ausführungsform des erfindungsgemäßen mobilen Telefons wird dieses in einem Kommunikationssystem zur medizinischen Überwachung eines Patienten eingesetzt. Dadurch ist es möglich, medizinische Daten zur Kontrolle des Gesundheitszustands von einer zentralen Leitstelle oder vom Hausarzt aus zu erfragen und even-

tuell notwendige Aktionen einzuleiten. Alternativ kann der Benutzer des mobilen Telefons mittels des im Telefon befindlichen WEB-Browsers die für seinen Gesundheitszustand relevante Information abrufen.

**[0022]** Die Erfindung wird im folgenden unter Bezugnahme auf die beigefügten Zeichnungen näher beschrieben. Es zeigen:

**Figur 1** ein Blockdiagramm eines Kommunikationssystems zur Überwachung eines Patienten, in dem das erfindungsgemäße mobile Telefon verwendet wird;

**Figur 2** ein Blockdiagramm der Implementierung des Kommunikationssystems nach Figur 1;

**Figur 3** ein Blockdiagramm eines Kommunikationssystems zur Überwachung und/oder Führung eines Fahrzeugs, in dem das erfindungsgemäße mobile Telefon verwendet wird; und

**Figur 4** ein Blockdiagramm der Implementierung des Kommunikationssystem nach Figur 3.

**[0023]** Figur 1 zeigt ein Blockdiagramm eines Kommunikationssystems, bei dem das erfindungsgemäße mobile Telefon (nicht gezeigt) verwendet wird, um einen Patienten medizinisch zu überwachen, wobei der in Figur 1 gezeigte Block 1 im mobilen Telefon enthalten ist.

**[0024]** Das mobile Telefon enthält folglich einen WEB-Server 2, der über eine Luftschnittstelle 3 mit einem als Server dienenden Service-Provider 4 koppelbar ist. Desweiteren ist der WEB-Server 2 über die Luftschnittstelle 3 mit einem als Client ausgebildeten autorisierten Browser 5 koppelbar. Der externe Service-Provider 4 und der externe autorisierte Browser 5 sind demnach über das Funknetz mit dem mobilen Telefon gekoppelt, wobei die Datenkommunikation über den im mobilen Telefon enthaltenen WEB-Server 2 erfolgt, der entweder Anfragen eines mobilen Browsers 6 nach außen weitergibt oder Anfragen von außen entgegennimmt und auswertet. Zur Auswertung wird eine lokale Datenbank 7 hinzugezogen, die in diesem Fall als Server fungiert. Umgekehrt kann die Datenbank 7 auch Client sein, wobei zur Aktualisierung ihres Datenbestands angeschlossene Geräte (zum Beispiel ein Glukosemeßsensor) über den WEB-Browser 2 abgerufen werden. WEB-Browser 6 und lokale Datenbank 7 sind ebenfalls im mobilen Telefon vorhanden.

**[0025]** Die von dem Glukosemeßsensor gemessenen Daten werden an einen im mobilen Telefon enthaltenen Glukosemessungs-Server 8 übertragen und dort gespeichert. Somit kann zum Beispiel ein medizinischer Service-Computer (autorisierter Browser 5) periodisch über den WEB-Server 2 die medizinischen Meßwerte (hier Glukosekonzentration) abfragen und bei Notfällen Instruktionen schicken. Bei akuten Notfällen (zum Beispiel Unterzuckerung) kann aber auch über den mobilen WEB-Browser 6 automatisch oder manuell Hilfe angefordert werden. Zur gezielten Notfallführung kann ein Service-Rechner über den autorisierten Browser 5, der



seine Zugangsberechtigung durch ein Passwort oder eine digitale Signatur nachweist, und den WEB-Server 2 von einem im mobilen Telefon enthaltenen GPS-Server 9 die Position des in Not geratenen Patienten erfragen.

**[0026]** Das mobile Telefon enthält ferner einen Herzschrittmacher-Server 10, der Information über den Arbeitsbereich des Herzschrittmachers enthält.

**[0027]** Desweiteren enthält das mobile Telefon einen Notfalldetektor-Server 11, der zum Beispiel über einen Beschleunigungssensor Information darüber erhält, ob der Patient gestürzt ist. Diese Information kann über den WEB-Server 2 jederzeit abgerufen werden, wobei in einem Notfall der WEB-Server 2 über den WEB-Browser 6 automatisch über die Luftschnittstelle 3 Hilfe anfordern kann.

**[0028]** Zur Auswertung der im GPS-Server 9, Glukosemessungs-Server 8, Herzschrittmacher-Server 10 und Notfalldetektor-Server 11 enthaltenen Information wird diese über den WEB-Server 2 an die Datenbank 7 übertragen, die mit einem weiteren Speichermedium 12 gekoppelt ist. Die Datenbank 7 ist folglich als Client oder Server betreibbar.

**[0029]** Figur 2 zeigt ein Blockdiagramm der Implementierung des medizinischen Kommunikationssystems nach Figur 1.

**[0030]** WEB-Server und -Browser sind Standardapplikationen, die für die konkreten Anwendungen lediglich etwas zugeschnitten werden müssen. Alle anderen Server können als C / C++-Programme realisiert werden, die Zugriff auf die Hardware besitzen (zum Beispiel Glukosemeßeinrichtung oder der GPS-Empfänger). Sie werden an den WEB-Server über ein CGI (common gateway interface) angeschlossen. Bei größeren Datenmengen ist es aufgrund der besseren Effizienz ratsam, die POST-Zugriffsmethode zu verwenden. Der Gateway-Server kommuniziert dabei mit dem WEB-Browser über Standard-Input und -Output.

**[0031]** Weil diese Teile des Systems nicht nach außen sichtbar sind, können sie leicht durch andere Technologien (zum Beispiel JAVA oder VRML) ausgetauscht werden. Als Ersatz für die im mobilen Einsatz nur beschränkt brauchbare Festplatte ist die Datenspeicherung in RAM oder FLASH vorgesehen.

**[0032]** Im Blockdiagramm nach Figur 2 ist ein mobiles Telefon 13 enthalten, in dem eine Sendeempfangseinheit 14 sowie eine Mikroprogrammsteuereinheit 15 (MCU) mit einem DSP vorhanden sind.

**[0033]** Der in Figur 1 gezeigte Block 1 ist bei dem Kommunikationssystem zur medizinischen Überwachung eines Patienten vollständig in der Mikroprogrammsteuereinheit 15 des erfindungsgemäßen mobilen Telefons 13 enthalten.

**[0034]** Über eine erste Antenne 16 ist das mobile Telefon 13 über die Sendeempfangseinheit 14 und eine Luftschnittstelle 17 mit einer Antenne 18 enthaltenen Basisstation 19 gekoppelt. Die Basisstation 19 kann zum Beispiel in einem GSM-System enthalten und über eine Mobilvermittlungsstelle (MSC) 20 mit einem Ser-

vice-Provider 21 gekoppelt sein.

**[0035]** Das mobile Telefon 13 ist ferner über eine Schnittstelle 22 mit einer Medizinelektronik 23 gekoppelt. Diese Medizinelektronik 23 enthält einen Glukosemeßsensor zur Bestimmung der Glukosekonzentration einer Person mit Diabetes oder einer anderen Stoffwechselerkrankung, die den Zuckerhaushalt beeinflusst. Die Glukosekonzentration kann dabei automatisch periodisch gemessen werden, wobei die Resultate über die Schnittstelle 22 an das mobile Telefon 13 übertragen werden. Der Transfer erfolgt bevorzugt drahtlos (zum Beispiel über eine HF-Übertragung mit geringer Leistung und Reichweite), um keine permanente mechanische Verbindung zwischen Meßgerät und Mobiltelefon haben zu müssen. Das Meßgerät sollte Werte bei Unterbrechung der Datenübertragung zusammen mit ihrer Entstehungszeit puffern. Alternativ können anstelle der periodischen automatischen Messung durch eine entsprechende Sensorelektronik die Blutzuckerwerte auch regelmäßig durch die Person mit Diabetes über eine Tastatur 24 in das Mobilterminal eingegeben werden.

**[0036]** Die Medizinelektronik 23 enthält ferner einen Herzschrittmacher mit einem Funkempfangs- und Sendemodul. Sobald problematische Arbeitsbereiche des Herzschrittmachers detektiert werden (zum Beispiel dauerhafte Überlastung wegen zu hoher körperlicher Aktivität, technische Probleme des Geräts) wird eine Nachricht über die Schnittstelle 22 an das in der Nähe befindliche Mobiltelefon 13 gesendet und über den WEB-Server 2 aus Figur 1 in der lokalen Datenbank 7 gespeichert. Wie bereits oben beschrieben, kann bei der Detektion eines problematischen Arbeitsbereichs des Herzschrittmachers der in der MCU 15 des Mobiltelefons 13 enthaltene WEB-Browser 6 automatisch gestartet werden, wobei zum Beispiel über einen Lautsprecher 25 eine akustische oder über ein Display 26 eine optische Warnnachricht ausgegeben werden kann. Alternativ kann auch über die Schnittstelle 17, die Basisstation 19 und die MSC 20 eine Warnnachricht an den Service-Provider 21 gesendet werden.

**[0037]** Die Medizinelektronik enthält weiter eine automatische Hilfeanforderung, die zum Beispiel über einen Beschleunigungssensor auszulösen ist, der Stürze oder Unfälle detektiert. Eine weitere technisch einfache Lösung besteht darin, daß der Patient sich per WEB-Browser periodisch bei einer Service-Stelle meldet. Bleibt die Nachricht aus, wird eine Sprachverbindung zum Patienten zur Rückfrage aufgebaut. Antwortet der Patient nicht, löst das Service-Center aufgrund des möglichen Notfalls eine Hilfsaktion aus. Der externe autorisierte Browser 5 aus Figur 1 kann über den WEB-Server des Telefons nachfragen und evtl. von einem GPS-Empfänger 27 die genaue Position der Person erfragen. Der GPS-Empfänger 27 kann dabei ebenfalls im Mobiltelefon 13 integriert sein, wobei er über eine zweite Antenne 28 die GPS-Satellitensignale empfängt.

**[0038]** Das mobile Telefon 13 enthält zusätzlich ein Mikrofon 29 sowie eine Kamera 30. Mit Hilfe des Mi-

krophons kann ein zum Beispiel gestürzter Patient Hilfe anfordern, falls er nicht mehr in der Lage ist, die Tastatur 24 zu bedienen. Das Mikrofon 29 kann sich zum Beispiel automatisch aktivieren, wenn der o. g. Beschleunigungssensor eine Hilfeanforderung auslöst.

**[0039]** Mit Hilfe der Kamera 30 kann eine Ferndiagnose eines Patienten durchgeführt werden, wobei bei einer Notbehandlung per Mobilfunk ein behandelnder Arzt sich auch visuell einen Eindruck von dem Patienten verschaffen kann.

**[0040]** Figur 3 zeigt ein Blockdiagramm eines Kommunikationssystems zur Überwachung und/oder Führung eines Fahrzeugs, in dem das erfindungsgemäße mobile Telefon verwendet wird, wobei für gleiche Bestandteile die gleichen Bezugsziffern wie in Figur 1 und 2 verwendet werden.

**[0041]** Für Fahrzeuganwendungen läßt sich mit geringen Änderungen das gleiche System aus Figur 1 und 2 verwenden. Die Datenverbindung zu medizinischen Geräten muß dabei lediglich durch Interfaces zur Fahrzeugelektronik und anderen Einbaugeräten ersetzt werden.

**[0042]** Figur 3 zeigt einen in einem mobilen Telefon (zum Beispiel in der MCU des mobilen Telefons) enthaltenen Block 1 mit einem WEB-Server 2, der mit einem als Client ausgebildeten WEB-Browser 6 gekoppelt ist.

**[0043]** Das in Figur 3 gezeigte Kommunikationssystem kann zum Beispiel zur Fahrzeugnavigation verwendet werden. Dazu fordert ein Benutzer über den WEB-Browser 6 von einem Service-Provider 4 eine Routenplanung an, indem er das Ziel und die Randbedingungen eingibt. Die Anforderung wird dann in eine Warteschlange eines Datenbank-Servers 7 eingeordnet. Der Datenbank-Client 7 verarbeitet nun die Anforderungen dadurch, daß er von einem GPS-Server 9 die aktuelle Position und von einem Airbag-Server 31 sowie von einem Diagnoseserver 32 den aktuellen Sicherheitszustand erfragt. Diese Information wird dann zum Service-Provider 4 geschickt. Als Antwort erhält der Fahrer eine lokale Straßenkarte zum Ziel, auf der der optimale Weg markiert ist. Der WEB-Browser 6 fragt nun periodisch den Datenbank-Server 7 ab, um für die aktuelle Position visuelle Informationen auf einem Bildschirm (in Figur 3 nicht gezeigt) auszugeben bzw. den Fahrer durch situationsgerechte akustische Meldungen zu leiten. Der Datenbasis-Client 7 bleibt im Hintergrund aktiv und verfolgt die GPS-Position des Fahrzeugs. Erreicht die Fahrzeugposition die Grenzen der lokalen Karte, sendet der Client automatisch eine Anfrage an den Service-Provider 4, um die lokale Karte zu aktualisieren. Zwischen zwei solchen Anfragen ist keine externe Datenverbindung nötig, da alles Wissen für die lokale Routenplanung sich im Fahrzeug befindet.

**[0044]** Der Datenbank-Client 7 überwacht den Sicherheitszustand des Fahrzeugs dadurch, daß er periodisch Anfragen an den GPS 9-, den Airbag 31- und den Diagnose-Server 32 sendet, um kritische Situation zu detektieren. Falls ein Unfall oder andere gravierende

Störungen auftreten, sendet der Datenbank-Client 7 automatisch einen Notruf an den Service-Provider. Dieser antwortet mit einer Beschreibung der zugehörigen von ihm einzuleitenden Aktion und öffnet einen Sprachkanal zum Fahrer. Damit kann ggf. der Gesundheitszustand der Fahrzeuginsassen nachgefragt werden oder eine Hilfsaktion effektiv geplant werden.

**[0045]** Figur 3 zeigt ferner einen als Client ausgebildeten autorisierten Browser 5, über den eine zentrale, beim Spediteur ausgebildete Transport-Datenbank (nicht gezeigt) auf die gesamte Fahrzeugflotte Zugriff besitzt. Ist eine Flottenmanagement-Applikation im Fahrzeug aktiv, sendet der lokale Datenbank-Client 7 periodisch GPS-Position, Ziel, Zustand und Fracht des Fahrzeugs zum zentralen Transport-Datenbank-Server, der diese Information speichert.

**[0046]** Das in Figur 3 gezeigte Kommunikationssystem kann ferner zum Diebstahlschutz und zur Fahrzeugverfolgung verwendet werden, wobei der Diebstahlschutz vom Fahrzeugbesitzer durch Senden eines Autorisierungsschlüssels an den Service-Provider 4 initiiert werden sollte. Falls jemand unerlaubt in das Fahrzeug eindringt, wird der lokale Datenbank-Client 7 automatisch gestartet, fragt periodisch vom GPS-Server 9 die aktuelle Position ab und sendet eine Alarmnachricht mit der Position zum Service-Provider 4. Dieser kann nun das Fahrzeug durch Eingriff in die Motorelektronik stilllegen. Alternativ kann die Position an die Polizeifahndung übermittelt werden.

**[0047]** Die Frage nach dem technischen Zustand eines Fahrzeugs bzw. dessen Instandhaltung kann durch Abfrage des Autodiagnose-Servers 32, der Zugriff auf die relevanten technischen Systeme im Auto hat, beantwortet werden. Die Auswertung der Diagnosedaten könnte nach Abfrage der Information mittels des WEB-Browsers 6 in einem lokal angeschlossenen Service-Computer erfolgen. Andernfalls kann diese Information von dem autorisierten externen WEB-Browser 5 abgefragt werden und in einer Service-Stelle (zum Beispiel Kfz-Werkstatt) ausgewertet werden. Mit dem letzteren Vorgehen kann ein entfernter Experte die Auswertung der Fahrzeugfehler durchführen.

**[0048]** Wie in Figur 3 gezeigt, enthält der Block 1 ferner einen Server 33 für andere Systeme. Dieser Server kann zum Beispiel zur Kontrolle von Fahrzeuggeräten, wie etwa der Heizung, verwendet werden. Die Kontrolle erfolgt dabei über den lokalen WEB-Browser 6 oder aber über den externen autorisierten Browser 5. Auf diese Weise ist es möglich, schon zu Hause oder am Arbeitsplatz die Fahrzeugheizung zu aktivieren.

**[0049]** Der WEB-Server 2 ist ferner mit einem Auto-HIFI-Server gekoppelt, auf dem zum Beispiel komprimierte Audio-Information abgespeichert ist. In Mobilfunkgeräten der dritten Generation (UMTS, Nachfolger von GSM) kann eine erheblich höhere Datenmenge übertragen werden. Damit wird es möglich sein, personalisiertes Internet-Radio- und Videodienste anzubieten, sofern die Gebühren dafür attraktiv sind

und eine einfache automatische Abbuchung existiert. Ein Benutzer tuned sich auf einen Internet-Kanal mittels Push-Technologie (d. h. er erhält ohne Nachfrage die aktuelle Information des Kanals, zum Beispiel ein Radioprogramm). Alternativ kann ein Benutzer seinen privaten WEB-Server kontaktieren, um sein gewünschtes Programm zu transferieren (zum Beispiel eine komprimierte Audio-CD). Die empfangenen Daten können komprimierte Audio-Information, MIDI-Musik oder komprimierte Video-Information sein. Diese Information kann vom Benutzer über den WEB-Browser 6 und den WEB-Server 2 abgerufen werden, wodurch das mobile Internet-Terminal ein Radio und einen tragbaren Fernseher ersetzt.

[0050] Figur 3 zeigt weiter einen im Block 1 enthaltenen Auto-Telefon-Server 35, der mit dem WEB-Server 2 gekoppelt ist, und auf den über den WEB-Browser 6 oder aber über den autorisierten Browser 5 zugegriffen werden kann.

[0051] Figur 4 zeigt ein Blockdiagramm der Implementierung des Kommunikationssystems nach Figur 3, wobei für gleiche Komponenten die gleichen Bezugsziffern wie in Figur 2 verwendet werden.

[0052] Figur 2 und Figur 4 unterscheiden sich lediglich dadurch, daß das mobile Telefon 13 in Figur 4 statt mit einer Medizinelektronik mit einer Fahrzeugelektronik 36 sowie einem Airbag-Sensor 37 gekoppelt ist (fest oder über Luftschnittstelle).

[0053] Der Airbag-Sensor 37 liefert kontinuierlich Signale an den Airbag-Sensor-Server 31 aus Figur 3, wobei bei einem Unfall der Datenbank-Client 7 aus Figur 3, der kontinuierlich den Airbag-Sensor-Server 31 abfragt, automatisch einen Notruf an den Service-Provider 21 über die Luftschnittstelle 17 sendet.

[0054] Die Fahrzeugelektronik 36 sendet ebenfalls kontinuierlich Daten an den Autodiagnose-Server 32 aus Figur 3. Wie bereits oben beschrieben, kann auf diesen Autodiagnose-Server 32 bei Bedarf zugegriffen werden, wobei auch über den autorisierten Browser 5 in die Fahrzeugelektronik eingegriffen werden kann.

#### Patentansprüche

1. Mobiles Telefon mit einem WEB-Browser, **dadurch gekennzeichnet, dass** mindestens ein WEB-Server, der Anfragen von außen entgegennimmt und auswertet, in der Mikroprogrammsteuereinheit (MCU) des mobilen Telefons enthalten ist.
2. Mobiles Telefon nach Anspruch 1, **dadurch gekennzeichnet, daß** der mindestens eine WEB-Server mit mindestens einem weiteren Server koppelbar ist.
3. Mobiles Telefon nach Anspruch 2, **dadurch gekennzeichnet, daß** der weitere Server im mobilen Telefon enthalten ist.

4. Mobiles Telefon nach einem der Ansprüche 1 bis 3, **dadurch gekennzeichnet, daß** der WEB-Server mit mindestens einem weiteren Client (7) koppelbar ist der im mobilen Telefon enthalten ist.

5. Mobiles Telefon nach einem der Ansprüche 1 bis 4, **dadurch gekennzeichnet, daß** der WEB-Server selbst als Client betreibbar ist.

6. Verwendung des mobilen Telefons nach einem der Ansprüche 1 bis 5 in einem Kommunikationssystem zur Überwachung und / oder Führung eines Fahrzeugs.

7. Verwendung des mobilen Telefons nach einem der Ansprüche 1 bis 5 in einem Kommunikationssystem zur medizinischen Überwachung eines Patienten.

#### Claims

1. Mobile telephone having a WEB browser **characterized in that** at least one WEB server, which receives and evaluates enquiries from the outside, is contained in the microprogram control unit (MCU) of the mobile telephone.

2. Mobile telephone according to Claim 1, **characterized in that** the at least one WEB server can be coupled to at least one further server.

3. Mobile telephone according to Claim 2, **characterized in that** the further server is contained in the mobile telephone.

4. Mobile telephone according to one of Claims 1 to 3, **characterized in that** the WEB server can be coupled to at least one further client which is contained in the mobile telephone.

5. Mobile telephone according to one of Claims 1 to 4, **characterized in that** the WEB server can itself be operated as a client.

6. Use of the mobile telephone according to one of Claims 1 to 5, in a communications system for monitoring and/or guiding a vehicle.

7. Use of the mobile telephone according to one of Claims 1 to 5, in a communications system for medical monitoring a patient.

#### Revendications

1. Téléphone mobile, muni d'un navigateur WEB, **caractérisé en ce qu'**au moins un serveur WEB, qui reçoit et évalue depuis l'extérieur des requêtes, est

contenu dans l'unité de commande à microprogramme (MCU) du téléphone mobile.

2. Téléphone mobile selon la revendication 1, **caractérisé en ce que** le au moins serveur WEB est susceptible d'être accouplé à au moins un autre serveur. 5
3. Téléphone mobile selon la revendication 2, **caractérisé en ce que** l'autre serveur est contenu dans le téléphone mobile. 10
4. Téléphone mobile selon l'une des revendications 1 à 3, **caractérisé en ce que** le serveur WEB est susceptible d'être susceptible d'être couplé à au moins un autre client (7), contenu dans le téléphone mobile. 15
5. Téléphone mobile selon l'une des revendications 1 à 4, **caractérisé en ce que** le serveur WEB lui-même peut fonctionner en tant que client. 20
6. Utilisation du téléphone mobile selon l'une des revendications 1 à 5, dans un système de communication pour la surveillance et/ou le guidage d'un véhicule. 25
7. Utilisation des téléphones mobiles selon l'une des revendications 1 à 5, dans un système de communication, servant à la surveillance médicale d'un patient. 30

35

40

45

50

55

7

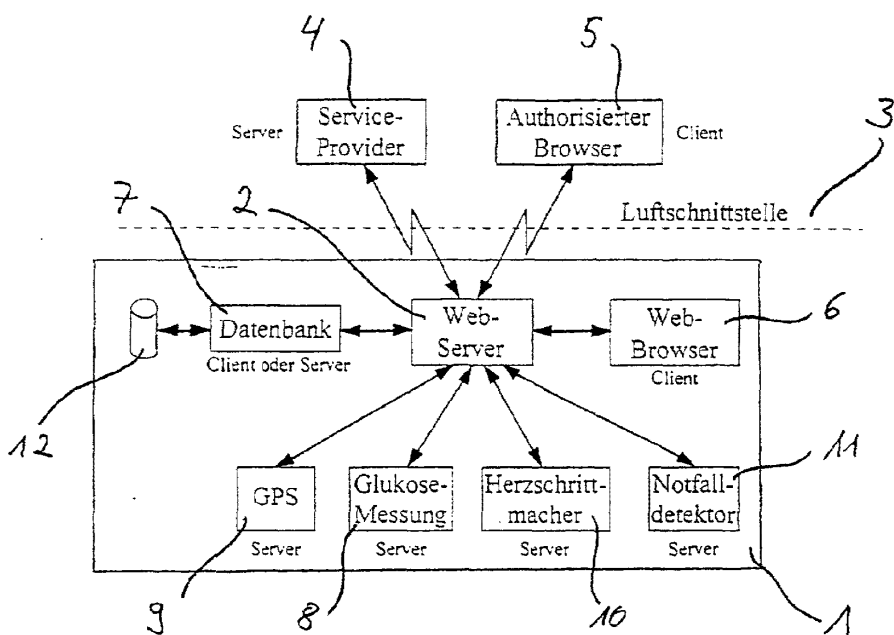


Fig. 1

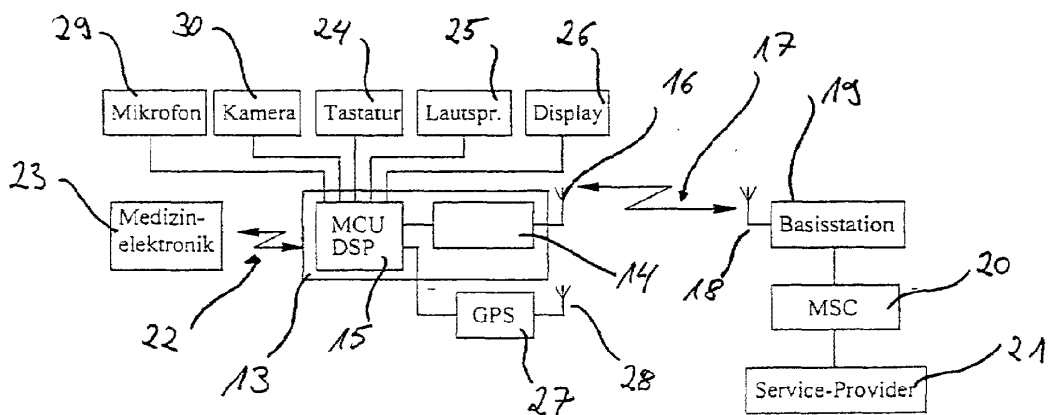


Fig. 2

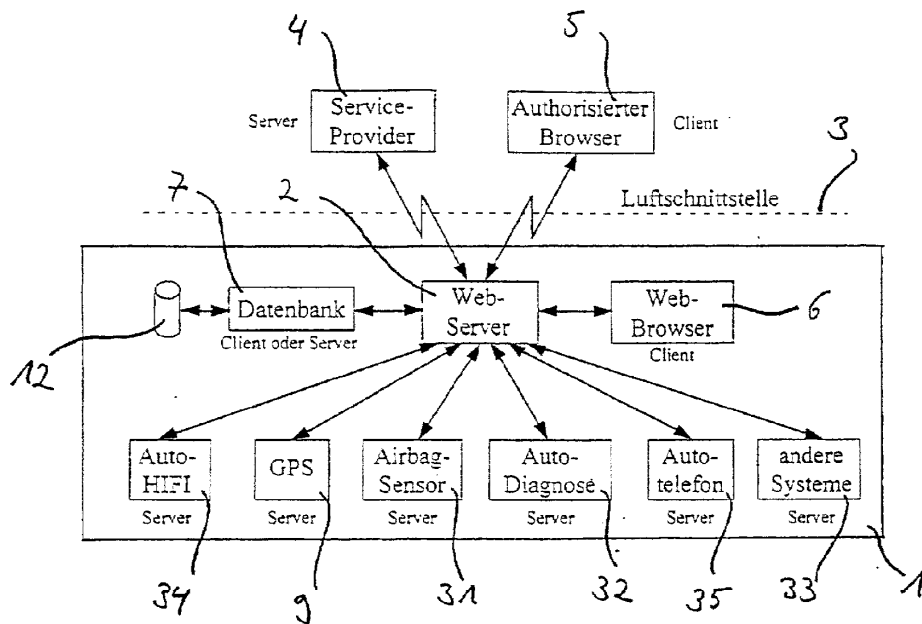


Fig. 3

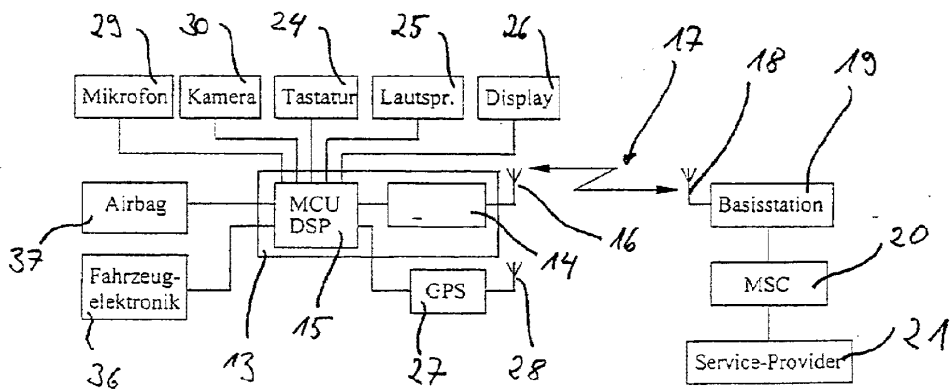


Fig. 4

(12) INTERNATIONAL APPLICATION PUBLISHED UNDER THE PATENT COOPERATION TREATY (PCT)

(19) World Intellectual Property Organization  
International Bureau



(43) International Publication Date  
18 January 2001 (18.01.2001)

PCT

(10) International Publication Number  
**WO 01/05078 A2**

- (51) International Patent Classification<sup>7</sup>: **H04J 3/16**
- (21) International Application Number: PCT/US00/18831
- (22) International Filing Date: 10 July 2000 (10.07.2000)
- (25) Filing Language: English
- (26) Publication Language: English
- (30) Priority Data:  
09/351,251 12 July 1999 (12.07.1999) US
- (71) Applicant and  
(72) Inventor: **WEINGARTEN, Walter, Jay** [US/US]; 2nd Floor, 2801-B Avenue P, Brooklyn, NY 11229 (US).
- (74) Agents: **COCH, Nicholas, L.** et al.; Kramer, Levin, Naf-talis & Frankel LLP, 919 Third Avenue, New York, NY 10022 (US).
- (81) Designated States (*national*): AE, AG, AL, AM, AT, AU, AZ, BA, BB, BG, BR, BY, BZ, CA, CH, CN, CR, CU, CZ, DE, DK, DM, DZ, EE, ES, FI, GB, GD, GE, GH, GM, HR, HU, ID, IL, IN, IS, JP, KE, KG, KP, KR, KZ, LC, LK, LR, LS, LT, LU, LV, MA, MD, MG, MK, MN, MW, MX, MZ, NO, NZ, PL, PT, RO, RU, SD, SE, SG, SI, SK, SL, TJ, TM, TR, TT, TZ, UA, UG, UZ, VN, YU, ZA, ZW.
- (84) Designated States (*regional*): ARIPO patent (GH, GM, KE, LS, MW, MZ, SD, SL, SZ, TZ, UG, ZW), Eurasian patent (AM, AZ, BY, KG, KZ, MD, RU, TJ, TM), European patent (AT, BE, CH, CY, DE, DK, ES, FI, FR, GB, GR, IE, IT, LU, MC, NL, PT, SE), OAPI patent (BF, BJ, CF, CG, CI, CM, GA, GN, GW, ML, MR, NE, SN, TD, TG).
- Published:**  
— Without international search report and to be republished upon receipt of that report.
- For two-letter codes and other abbreviations, refer to the "Guidance Notes on Codes and Abbreviations" appearing at the beginning of each regular issue of the PCT Gazette.*



**WO 01/05078 A2**

(54) Title: TRANSPARENT SYSTEMS FOR COMMUNICATION OVER COMPUTER NETWORKS

(57) Abstract: Telephonic, radio, and television systems for communication over computer networks conduct audio, video and other forms of communication over computer networks upon entry of appropriate input on devices included within the telephonic, radio, and television systems.

TRANSPARENT SYSTEMS FOR COMMUNICATION OVER  
COMPUTER NETWORKS

CROSS-REFERENCE TO RELATED APPLICATIONS

This application is a continuation-in-part of application number  
5 09/318,884, filed on May 26, 1999, which is a continuation-in-part of  
application number 08/687,180, filed on July 25, 1996.

BACKGROUND OF THE INVENTION

FIELD OF THE INVENTION

This invention relates to systems for communicating over  
10 computer networks and, more particularly, to systems allowing for  
communication of data over computer networks for the benefit of a user  
with improved ease of access to the data for the user.

DESCRIPTION OF THE RELATED ART

Computer networks interconnecting a large number of  
15 computers owned by different users are proliferating at an ever  
accelerating rate. One extremely popular and well known network is the  
Internet which links many hundreds of thousands of computers owned by  
almost as many businesses, educational institutions, governmental  
agencies, and individuals.

20 There has been much interest of late in using the Internet  
and other computer networks to conduct long-distance telephone  
conversations. The advantage of using the computer networks in this  
fashion involves avoiding using the conventional long-distance telephone  
network, and incurring telephone company charges.



Such efforts commonly have involved the use of a software package installed on a personal computer (PC) equipped with a sound card, microphone, and speakers enabling the PC to produce audible sounds, such as audible sounds encoded on CD-ROM (compact disk -  
5 read-only memory) disks which are placed in CD-ROM disk drives in certain personal computers. The software package allows a first user of a PC to employ the sound card, microphone, and speakers as the equivalent of a telephone, with the sound card, microphone, and speakers either receiving the first user's voice for transmission to a second user  
10 with whom the first user is conversing or transmitting the second user's voice to the first user. Some versions of such software allow only half duplex use, or in other words, either conversant may either talk or listen, but not both simultaneously, but more recent versions allow full duplex use equivalent to conventional telephone communications where  
15 conversants may talk and listen simultaneously. Such software includes "Internet Phone" produced by VocalTec Inc., of Northvale, New Jersey, "WebTalk" produced by Quarterdeck Corp. of Santa Monica, California, and "WebPhone" produced by NetSpeak Corporation of Boca Raton, Florida.

20 The audio signal in appropriate digital form travelling over the Internet from a PC will normally enter the Internet just like any other digital data through a local Internet Service Provider (ISP). The appropriate digital form will be in groups of digital information known as

packets, each packet containing both the data representing the audio signal and control information telling the Internet what to do with the packet. Since these ISPs exist worldwide as "gateways" to the Internet, persons with PCs connected to the Internet can conduct telephone conversations at  
5 no added cost over the access charges paid to their ISP. Because of poor voice quality, delays, and lost connections experienced during Internet conversations, special servers have been or will be installed at many ISPs to handle the increase in Internet traffic due to Internet voice communications.

10 One callback and Internet access provider, International Discount Telecommunications Corp. (IDT) of Hackensack, New Jersey, has demonstrated a prototype that purportedly allows a PC anywhere in the world having enough memory, a microphone, speakers, a sound card, and an IDT account to be connected to a telephone in the United States.

15 Despite the rapid advances and improvements in Internet telephony, several disadvantages remain. The participants in any such conversation all require PCs to conduct a conversation, all of the PCs must be connected to the Internet for the conversation to begin, and all of the PCs must have the same Internet telephony software as no software  
20 package currently being marketed is compatible with any other package. The IDT prototype requires one PC with peripherals online for a conversation to occur.

In addition, the sound cards and speakers as well as insufficient PC memory cause communication problems. For example, frequent volume adjustment to the speakers is necessary on both ends of the communications link to obtain audible communication and control of background noises.

The potential of the Internet and other computer networks to communicate other forms of information beside telephone conversations in a transparent and easily accessible manner has only been barely attempted. One of these largely unexplored areas is the use of computer networks to communicate live radio broadcasts and other forms of recorded audio communication. There appear to be Internet radio services, as well as traditional radio stations, that allow users of computers to access audio channels and conventional radio programming over the Internet, *see New York Times*, May 17, 1999, p. C11. However, it would be particularly advantageous if live radio broadcasts or other audio communication would be accessible to a user with a device possessing the general appearance and simplicity of use associated with a conventional radio.

Similarly, the use of computer networks to communicate live television broadcasts and other forms of recorded video communication would be highly desirable. It would be particularly convenient if such television broadcasts or other video communication

would be accessible to a user with a device possessing the general simplicity and ease of use associated with a conventional television.

The present invention makes substantial progress in presenting practical "information appliances" to communicate information to a user which is desired in real time with improved ease of access to the information for the user.

#### SUMMARY OF THE INVENTION

The present invention comprises devices which connect directly to the Internet or other computer network without the need for a PC being present between the devices and the computer network.

In a first embodiment of the invention, the telephonic device comprises a custom designed telephone hardwired with a microcontroller. The custom designed telephone is equipped with a separate alphabetic keypad as well as a numeric one. The microcontroller is programmed so as to respond to the dialing of the alphabetic host address, which is analogous to an electronic mail (e-mail) address, or its equivalent, a number known as the Internet Protocol (IP) address, of the telephone of the party called by sending out an appropriate signal to the telephone of the party called over the Internet, thus causing the telephone of the party called to ring. The party called then can pick up the telephone and the telephone conversation can commence. The telephone of the party called

is of the same custom design as the telephone of the calling party. Both custom designed telephones are constantly connected to the Internet through the ISP of each party and are, thus, ordinarily unavailable for traditional use.

5                   A second embodiment of the invention differs from the first embodiment in that the microcontroller is not integral with the telephone, but is contained in an electronic box plugged into the phone, but separate from it. This embodiment allows the use of a telephone which only differs from a conventional telephone by the presence of a separate alphabetic  
10                   keypad. This telephone can be unplugged from the system and used as a conventional telephone, as contrasted to the custom designed telephone included in the first embodiment of the invention.

                  A third embodiment of the invention involves the use of conventional telephones, Central Exchange (centrex), Private Branch  
15                   Exchange (pbx), or a PC-based switching system (pcex), and the Internet. In this embodiment, one conversant is able to use a telephone to call a centrex, pbx, or pcex connected to the Internet. The call goes go through the Internet to a second centrex, pbx, or pcex which completes the call through the regular telephone lines.

20                   A fourth embodiment of the invention is similar to the first embodiment of the invention in that a custom designed telephone hardwired with a microcontroller is disclosed. However, the microcontroller is programmed so that the telephone need not always be

connected to the Internet to make and receive telephone calls over the Internet and can, thus, be used as an ordinary telephone when calls are not being made over the Internet. The microcontroller is programmed so that when a call over the Internet is initiated by dialing the telephone number of a called telephone, the alphabetic host address or IP address of the calling telephone, and the alphabetic host address or IP address of the called telephone, the calling telephone first calls over the conventional telephone lines, transmitting the alphabetic host address or IP address of the calling telephone to the called telephone and then hangs up. The called telephone, having a microcontroller programmed in a manner compatible with that of the calling telephone, then dials the alphabetic host address or IP address of the calling telephone, while the calling telephone dials the alphabetic host address or IP address of the called telephone, resulting in both of the telephones being connected to the Internet only when a voice conversation between the owners of the telephones occurs.

A fifth embodiment of the invention differs from the fourth embodiment of the invention in that a device or devices capable of sending and/or receiving data other than an audio signal over the Internet is incorporated into the telephone.

A sixth embodiment of the invention allows a user to listen to live or prerecorded radio broadcasts by use of the Internet. In this way, radio stations traditionally broadcasting by the wireless mode, which indeed defines conventional radio, can increase their available bandwidth

for broadcasting greatly, and a new mode of communication which can be named "Internet network radio" will be born. The radio station and the user's "Internet radio" are both connected to the Internet by conventional telephone lines.

5                   A seventh embodiment of the invention differs from the sixth embodiment in that the radio station broadcasts in wireless mode to its ISP instead of being connected to it by conventional telephone lines.

                  An eighth embodiment of the invention differs from the sixth embodiment in that the user's "Internet radio" is connected in a  
10                   wireless manner to its ISP rather than through conventional telephone lines.

                  A ninth embodiment of the invention differs from the sixth embodiment of the invention in that both the radio station and the "Internet radio" communicate with their respective ISPs in a wireless manner rather  
15                   than through conventional telephone lines.

                  A tenth embodiment of the invention allows a user to listen to live or prerecorded audio information transmitted over the Internet on virtually any subject that can be imagined.

                  An eleventh embodiment of the invention allows a user to  
20                   listen to live or prerecorded television broadcasts by use of the Internet. In this way, television stations, traditionally broadcasting by wireless transmission, can increase their available bandwidth for broadcasting greatly, and a new mode of communication by television transmitted by

television stations over computer networks to television receivers will be born. The television station and the user's Internet television are both connected to the Internet by conventional telephone lines.

5 A twelfth embodiment of the invention differs from the eleventh embodiment of the invention in that the television station broadcasts in wireless mode to its ISP instead of being connected to it by conventional telephone lines.

10 A thirteenth embodiment of the invention differs from the eleventh embodiment of the invention in that the user's Internet television is connected in a wireless manner to its ISP rather than through conventional telephone lines.

15 A fourteenth embodiment of the invention differs from the eleventh embodiment of the invention in that both the television station and the "Internet television" communicate with their respective ISPs in a wireless manner rather than through conventional telephone lines.

A fifteenth embodiment of the invention allows the user to see live or prerecorded video information transmitted over the Internet on virtually any subject that can be imagined.

20 A sixteenth embodiment of the invention differs from the eleventh embodiment of the invention in that the user's television is a conventional television which is converted to an Internet television by a set top box.



It is an object of this invention to conduct voice conversations over computer networks without the use of computers.

It is a further object of this invention to initiate voice conversations over computer networks despite the absence of any initial  
5 working connection between the devices used for the voice conversations and the computer networks.

It is a still further object of this invention to standardize voice communication over computer networks so that incompatible equipment does not prevent such communication.

10 It is yet a further object of this invention to provide devices capable of enabling voice communications and other forms of data communication simultaneously over computer networks.

It is yet another object of this invention to permit the dissemination of audio information from at least one source, such  
15 information being broadcast in real time or being previously recorded, to at least one listener over computer networks.

It is still another object of this invention to allow the dissemination of such audio information to listeners without the use of computers by such listeners.

20 It is still another object of this invention to permit the dissemination of video information from at least one source, such information being broadcast in real time or being previously recorded, to at least one listener over computer networks.

It is still another object of this invention to allow the dissemination of such video information to viewers without the use of computers by such viewers.

5 These and other objects and advantages of the present invention will become more apparent to those of ordinary skill in the art upon consideration of the attached drawings and the following description of the preferred embodiments which are meant by way of illustration and example only, but are not to be construed as in any way limiting the invention disclosed and claimed herein.

10

#### BRIEF DESCRIPTION OF THE DRAWINGS

Fig. 1 is a schematic diagram of the first embodiment of the invention.

Fig. 2 is a schematic diagram of the second embodiment of the invention.

15

Fig. 3 is a schematic diagram of the third embodiment of the invention.

Fig. 4 is a schematic diagram of the fourth embodiment of the invention.

20

Fig. 5 is a schematic diagram of a telephonic device used in the fifth embodiment of the invention.

Fig. 6 is a schematic diagram of the sixth embodiment of the invention.

Fig. 7 is a schematic diagram of the seventh embodiment of the invention.

5 Fig. 8 is a schematic diagram of the eighth embodiment of the invention.

Fig. 9 is a schematic diagram of the ninth embodiment of the invention.

10 Fig. 10 is a schematic diagram of the tenth embodiment of the invention.

Fig. 11 is a plan view of an enhanced Internet radio

Fig. 11A is a view of Fig. 11 taken along section lines 11A-11A.

15 Fig. 11B is a view of Fig. 11 taken along section lines 11B-11B.

Fig. 12 is a plan view of a remote control device for an enhanced Internet radio.

Fig. 12A is a view of Fig. 12 taken along section lines 12A-12A.

20 Fig. 13 is a schematic diagram of an arrangement of an enhanced Internet radio, earphones, and a remote control device.

Fig. 14 is a schematic diagram of an enhanced Internet radio, earphones, a remote control device, and speakers in a free-standing configuration.

5 Fig. 15 is a schematic diagram of an enhanced Internet radio with earphones, a remote control device, and speakers in a wall-mounted configuration.

Fig. 16 is a schematic diagram of an enhanced Internet radio, earphones, a remote control device, speakers in a wall-mounted configuration, and a CD player or hard drive attached to the enhanced  
10 Internet radio.

Fig. 17 is a schematic diagram of the eleventh embodiment of the invention.

Fig. 18 is a schematic diagram of the twelfth embodiment of the invention.

15 Fig. 19 is a schematic diagram of the thirteenth embodiment of the invention.

Fig. 20 is a schematic diagram of the fourteenth embodiment of the invention.

20 Fig. 21 is a schematic diagram of the fifteenth embodiment of the invention.

Fig. 22 is a schematic diagram of a portion of the sixteenth embodiment of the invention.

Fig. 23 is a schematic diagram showing an enhanced Internet television along with a remote control device.

Fig. 24 is a schematic diagram showing an enhanced Internet television with wall-mounted speakers and a remote control device.

Fig. 25 is a schematic diagram showing an enhanced Internet television with speakers in a free-standing configuration and a remote control device.

Fig. 26 is a schematic diagram showing an enhanced Internet television with wall-mounted speakers, a remote control device, and a CD player or hard drive attached to the enhanced Internet television.

#### DESCRIPTION OF THE PREFERRED EMBODIMENTS

For a more detailed description of the invention in its several embodiments given only by way of example and not to be construed as limiting the invention in any fashion, we refer to the drawings.

Fig. 1 represents the first embodiment of the invention. In this embodiment, a first telephone 2 and a second telephone 4 are of the same design, each containing a microcontroller 6 allowing the first telephone 2 and the second telephone 4 to make and receive telephone calls over the Internet 8 or another computer network and a separate

alphabetic keypad as well as a numeric one. (It should be understood that a conventional telephone numeric keypad can be used in combination with a separate alphabetic keypad, although the presence of multiple letters over the numbers in such a numeric keypad would be redundant and possibly  
5 confusing to the user.) Alternatively, each telephone could have a conventional telephone numeric keypad and extra selection keys such as, for example only, "shift", "ctrl", or "alt", to select between the multiple letters shown over some of the numbers on the conventional telephone numeric keypad. (A conventional telephone numeric keypad could also be  
10 used, without any extra selection keys, in a rather inconvenient manner by making use of the keys without letters to select letters.) The first telephone 2 is connected to the Internet 8 through a first conventional telephone line 7 and the ISP 10 of the party owning the first telephone 2 and the second telephone 4 is connected to the Internet 8 through a second  
15 conventional telephone line 9 and the ISP 12 of the party owning the second telephone 4.

As an example of the operation of the invention, if the party owning the first telephone 2 wishes to call the party owning the second telephone 4, the party owning the first telephone would preferably dial  
20 alphabetic symbols corresponding to the alphabetic host address of the second telephone 4 or the numeric equivalent of the alphabetic host address, a number corresponding to the IP address of the second telephone 4.

The use of an alphabetic host address would be most convenient to connect a call to those Internet users whose IP addresses for their telephones are dynamically allocated every time they are connected to the Internet. The use of an IP address is a viable alternative  
5 convenient to connect a call to those Internet users who have permanent IP addresses for their telephones.

A typical alphabetic host address, which is analagous to an e-mail address, might be jones@johnson.com. If this were an e-mail address, the address would signify that jones is a user on a computer  
10 named johnson in the Domain Name System (DNS) domain named com. (The Internet is subdivided into administrative units containing groups of participating computers called domains.) Analogously, since we are dealing with a telephone that is the host, instead of a computer, the address signifies that jones is a user on a telephone named johnson in the  
15 Internet domain named com.

The IP address, which is the numeric equivalent of the alphabetic host address, is typically expressed in dot notation. For example, 198.95.262.38 is a typical IP address. Of course, the microcontroller 6 could be programmed so that it would respond without  
20 the use of the dots or the dots could be replaced by the use of the "\*" key on the typical touch tone telephone keypad.

It should be noted that an IP address identifies one network interface on a host. Thus, if a host, in our case, a telephone, has two or

more network interfaces (see fifth embodiment of invention below), the host will have a different IP address for each network interface. Each IP address, as presently assigned by the authorities responsible for assigning such addresses on the Internet, is a 32-bit binary number written as 4  
5 fields, 8 bits each, separated by dots. (The typical IP address given above is the decimal equivalent of the binary address.) Due to the sheer number of devices being connected to the Internet, the available addresses are running low. Any extension of the IP addressing system to cover additional addresses, whether IPng (Internet Protocol Next Generation),  
10 also known as IPv6 (Internet Protocol, Version 6), or another subsequent scheme which is numerically based, can be easily accommodated by the invention as disclosed herein.

In any event, the microcontroller 6 of the first telephone 2 is programmed to send out a signal 14 which is relayed by the ISP 10 of  
15 the party owning the first telephone 2 and the ISP 12 of the party owning the second telephone 4 to the second telephone 4 causing the second telephone 4 to ring. The owner of the second telephone 4 can then pick up the second telephone 4 and a conversation can begin between the owner of the first telephone 2 and the owner of the second telephone 4.

20 The signal 14 travels over the Internet 8 using the TCP/IP (Transmission Control Protocol/Internet Protocol) suite of protocols for transmission of data over the Internet. Since the type of communication ordinarily to be effected by the invention disclosed herein is simple voice,



text, audiovisual, or visual communication where everything is transmitted in realtime mode and data may be easily resent if corrupted in the transmission, those protocols in the TCP/IP suite which do not perform extensive error checking on packets sent may be used, instead of those more appropriate for data where visual and mathematical accuracy is a critical consideration. Thus, User Datagram Protocol (UDP), which causes data to flow on the Internet without error checking, may be used by the microcontroller 6 of the telephones 2,4 to transmit voice instead of the more conventional TCP which provides for such error checking. This will allow for more efficient transmission of voice by the disclosed invention than would be possible if conventional PCs using TCP to transmit voice were used.

The embodiment of the invention depicted by Fig. 1, however, requires that the first telephone 2 and the second telephone 4 be "dedicated" telephones constantly connected to the Internet 8 and therefore unavailable for use with the conventional telephone network unless they are connected to the telephone network over Integrated Services Digital Network (ISDN) lines, a Digital Subscriber Line (DSL), or cable television lines, which would possibly allow each telephone to be used for calling over the conventional telephone lines even though they are also connected to the Internet.

A second embodiment of the invention is shown in Fig. 2. A first telephone 20 and a second telephone 24 are connected to the

Internet 8. The first telephone 20 has an electronic box 28 connected to it, the electronic box 28 containing a microcontroller 6. The second telephone 24 has an electronic box 32 connected to it, the electronic box containing a microcontroller 6.

5                    Similarly to Fig. 1, the first telephone 20 is connected to the Internet 8 through a first conventional telephone line 25 and the ISP 40 of the party owning the first telephone 20 and the second telephone 24 is connected to the Internet 8 through a second conventional telephone line 33 and the ISP 42 of the party owning the second telephone 24. The  
10                    functionality of the microcontroller 6 is identical to that described in connection with Fig. 1. However, its physical location has changed from inside the telephones 2,4 shown in Fig. 1 to outside the telephones 20,24 shown in Fig. 2 and inside separate electronic boxes 28,32. The telephones 20,24 have the alphabetic and numeric keypads or,  
15                    alternatively, a conventional telephone numeric keypad with extra selection keys, as described for the telephones 2,4 shown in Fig. 1. Alternatively, the alphabetic keypad or extra selection keys may be placed on the separate electronic boxes 28, 32. Finally, the operation of the invention, upon the party owning the first telephone 20 dialing the alphabetic host  
20                    address or IP address of the second telephone 24, would be the same as that described in Fig. 1 upon the party owning the first telephone 2 dialing the alphabetic host address or IP address of the second telephone 4.

The advantage of the embodiment shown in Fig. 2 over that shown in Fig. 1 is that the telephones 20,24 can be unplugged from their respective electronic boxes 28,32 and used as conventional telephones communicating over the conventional telephone network since they have at least a numeric keypad. The telephones 2,4 shown in Fig. 1, on the other hand, cannot ordinarily be used as conventional telephones since they are constantly connected to the Internet.

Fig. 3 shows a third embodiment of the invention. In this embodiment, a first conventional telephone 50 and a second conventional telephone 52 can make and receive telephone calls over the Internet 8. This is possible because the first telephone 50 and the second telephone 52 are connected to telephone switching equipment 54 that is connected to the Internet 8, instead of to the conventional telephone network. This telephone switching equipment can be in the form of a centrex 56, pbx 58, or pcex 60. This telephone switching equipment 54 will work in an analagous manner to that found in the conventional telephone network, but it will be connecting subscriber telephones connected to the Internet 8 to each other.

As an example of the operation of the invention in accordance with this embodiment, if the party owning the first telephone 50 wishes to call the party owning the second telephone 52, the party owning the first telephone 50 will simply dial the telephone number of the party owning the second telephone 52. Then the signal 64 produced by

the first telephone 50, instead of traveling solely on the conventional telephone lines, will first travel over the conventional telephone lines 68 to telephone switching equipment 54, which may be any one of centrex switching equipment 56, pbx switching equipment 58, or pcex switching equipment 60, connected on one side to the first telephone 50 through the conventional telephone lines 68 and on the other side to the Internet 8. This switching equipment 54 will relay the signal 64 through the Internet 8 such that it is received by a second arrangement of switching equipment 54, which may again be any one of centrex switching equipment 56, pbx switching equipment 58, or pcex switching equipment 60, which is connected on one side to the Internet 8 and on the other side through conventional telephone lines 69 to the second telephone 52. The second arrangement of switching equipment 54 relays the signal 64 through conventional telephone lines 69 to the second telephone 52. When the second telephone 52 receives the signal 64 it rings and the party owning the second telephone 52 can pick up the receiver and a conversation can begin.

This third embodiment of the invention allows the use of completely conventional telephones and switching equipment to speak over the Internet, but requires that the switching equipment be connected to the Internet.

Fig. 4 shows the fourth embodiment of the invention. Analogously to the first embodiment shown in Fig. 1, there are a first telephone 70 and

a second telephone 72 connected to the Internet 8 and capable of making and receiving calls over the Internet 8. Each telephone 70,72 is custom designed and contains a microcontroller 74. Each telephone has both a numeric keypad and an alphabetic keypad or, alternatively, a conventional telephone numeric keypad with extra selection keys as previously described in connection with the telephones 2,4 shown in Fig. 1. Analogously to Fig. 1, the first telephone 70 is connected to the Internet 8 through a first conventional telephone line 75 and the ISP 76 of the owner of the first telephone 70 and the second telephone 72 is connected to the Internet 8 through a second conventional telephone line 77 and the ISP 78 of the owner of the second telephone 72. However, unlike the embodiment of Fig. 1, the telephones 70,72 need not always be connected to the Internet 8, but may also be used for calls over the conventional telephone lines without the use of ISDN lines because of the method by which Internet telephone calls are connected. To demonstrate this method of operation, we consider a concrete example.

If the owner of the first telephone 70 desires to make a call over the Internet 8 to the owner of the second telephone 72, the owner of the first telephone 70 would dial the alphabetic host address or the IP address of the first telephone 70 and the alphabetic host address or the IP address of the second telephone 72 followed immediately by the regular telephone number of the second telephone 72. Of course, the order of dialing the various alphabetic host or IP addresses and the telephone

number is only given by way of example and may be varied depending on the programming of the microcontroller 74.

The microcontroller 74 in the first telephone 70 would be programmed to respond to the dialing of the combined alphabetic host or IP addresses and the telephone number by transmitting, over the  
5 conventional telephone lines 80 connecting the two telephones 70,72, the alphabetic host address or the IP address 82 of the first telephone 70 to the second telephone 72. The first telephone 70 would then terminate the connection with the second telephone 72. The second telephone 72 would  
10 then dial the alphabetic host or IP address of the first telephone 70, causing a connection to the first telephone 70 through the ISP 78 of the owner of the second telephone 72 and the ISP 76 of the owner of the first telephone 70. While the second telephone 72 is dialing the alphabetic host or IP address of the first telephone 70, the first telephone 70 is dialing the  
15 alphabetic host or IP address of the second telephone 72, causing a connection to the second telephone 72 through the ISP 76 of the owner of the first telephone 70 and the ISP 78 of the owner of the second telephone 72. (It should be understood that "handshaking" or the process through which both telephones 70, 72 connect to each other can occur through  
20 numerous methods well known to those skilled in the art. For example, after the initial transmission of the alphabetic host address or IP address 82 of the first telephone 70 to the second telephone 72 over the conventional telephone lines 80, it may only be necessary for either one

of the first telephone 70 or the second telephone 72 to dial the alphabetic host address or IP address of the other telephone for the telephones 70,72 to be connected to each other over the Internet.) Thus, both telephones 70,72 have been connected to the Internet 8 through the special dialing sequence on the first telephone 70 and by the special subsequent calling sequence previously described and they are only connected to the Internet 8 for conducting a telephone conversation by the special dialing sequence on one of the telephones 70,72 specified above. If a regular telephone number is dialed, the telephones 70,72 would react as a conventional telephone, placing the call over the conventional telephone lines 80.

This embodiment thus allows the telephones 70,72 to make and receive calls over the Internet 8 when desired or, if the Internet 8 is too busy or for some other reason is unsuitable for communication, over the conventional telephone lines 80.

The fifth embodiment of the invention differs from the fourth embodiment of the invention in the telephones used. These telephones 80, one of which is shown in Fig. 5, differ from the telephones 70,72 shown in Fig. 4 insofar as they incorporate a device or devices 82 capable of sending or receiving or sending and receiving data over the Internet other than audio data and insofar as they have added functionality over that described for the telephones 70,72 and thus require a microprocessor 84 programmed to perform such additional functions. These telephones 80 will function, as did the telephones 70,72 in the

fourth embodiment of the invention, to establish a telephone conversation between the owners of the telephones.

However, once such a conversation is established one or the other of the conversants may wish to use the device or devices 82 on the telephone to send data other than voice to the other conversant. Of course, in such an instance the device or devices 82 on the two telephones involved must be compatible to send or receive, as required, the data desired. This device or devices 82 may include, but are not limited to, facsimile transmission devices, including devices which can process color facsimiles or even three-dimensional facsimiles which are created by laser mathematically measuring solid objects, devices which can send or receive live or recorded video with or without an accompanying sound track, devices which can send or receive still pictures, and screens of all types for displaying text or graphical data. Since, as explained earlier, any such device or devices 82 must each have a separate IP address, the IP address of the device 82 called to receive data will be entered prior to such transmission taking place.

For example, assume the owner of a first telephone 80 which has a device 82 comprising a color facsimile transmitting device wishes to send a color facsimile to a second telephone 80' having a device 82' comprising a color facsimile receiving device. The owner of the first telephone 80 would enter the IP address or, equivalently, the alphabetic host address of the device 82' on the first telephone's keypad and this



would cause the microcontroller 84 to establish a connection over the Internet to the device 82'. The color facsimile could then be sent from device 82 to device 82' while the owners of the two telephones 80,80' are conversing, provided that the telephone lines to the respective ISP's of the owners of the two telephones 80,80' will accomodate such simultaneous data transfer.

It should, of course, be understood that the telephones included in the fifth embodiment of the invention could be used to transmit data other than audio communication even in the absence of a telephone conversation. This would be done by following a process completely analogous to that described in the fourth embodiment of the invention for initiating a telephone call except that IP addresses or alphabetic host addresses of the sending or receiving or sending and receiving devices would be used, instead of IP addresses or alphabetic host addresses of the telephones into which those sending or receiving or sending and receiving devices are incorporated.

All embodiments of the telephonic devices described above using IP addresses or alphabetic host addresses to initiate a conversation between users of two telephonic devices could possess the ability to recognize a limited number of telephone numbers by the availability of a memory in the telephonic devices storing such limited number of telephone numbers and their equivalent IP or alphabetic host addresses. In addition, the use of such IP or alphabetic host addresses may be rendered

unnecessary in the future if telecommunications companies owning or operating the conventional telephone network assign telephone numbers to these telephonic devices.

Furthermore, all embodiments of the telephonic devices described above, except for the third embodiment of the invention, which  
5 assumes the use of completely conventional telephones, could possess the capacity to accept voice commands through voice recognition. Such a capability could be used, for example, by a voice command to the telephonic device to dial a certain IP address, alphabetic host address, or  
10 telephone number, assuming the telephonic device can recognize the telephone number as mentioned in the prior paragraph.

Such voice recognition capability can be combined with a more extensive memory capable of storing, in addition to telephone numbers and their equivalent IP or alphabetic host addresses, voiceprints  
15 of frequent callers or unwanted callers and names of persons associated with any telephone numbers stored in the memory. In such a case, the telephonic device could have the capability to identify a limited number of callers by voiceprint, the telephonic device could respond to a voice command to call the telephonic device of one of the persons whose names  
20 are stored in its memory, and the telephonic device could be told to call a certain person whose name was stored in its memory and, if the person did not answer the call, leave a message prerecorded by a user of the telephonic device, assuming that the telephonic device has a limited

recording capability. If the telephonic device has a clock or other equivalent time keeping device, the telephonic device could be told to call a person at a future time. Finally, if the telephonic device is programmed with software capable of changing or distorting a voice, the telephonic device would be able to change or distort voices transmitted or received.

Fig. 6 shows a sixth embodiment of the invention. In this embodiment, an Internet radio 86 is connected by conventional telephone lines 88 to an ISP 90 providing Internet services to the user of the Internet radio 86. A radio station 92 is also connected by conventional telephone lines 94 to an ISP 96 likewise providing Internet services to the radio station 92. Although the radio station 92 may be a conventional radio station, it may also be a private transmitter in a residential or other nonconventional location.

When a user of the Internet radio 86 desires to "tune in" to the radio station 92 and listen to whatever audio communication is then being broadcast by that radio station 92, the user activates the Internet radio 86 which may be battery powered or connected to a conventional electrical outlet just like a conventional radio. The user then tunes the Internet radio 86 to the station's frequency precisely in the same manner that the user would tune a conventional radio to that frequency. Upon being tuned to the frequency of the radio station 92, the Internet radio 86 will immediately transmit in audible form the broadcast of the radio station 92.

The process which insures this result is as follows. The radio station 92, at the same time that it generates radio waves 98 corresponding to the audible sounds being generated by a live event or by audio tapes being played in its studio, sends out a digital signal 100 over the conventional telephone lines 94 connecting it to its ISP 96. That digital signal 100 preferably also corresponds as fully as do the radio waves 98 to the audible sounds being generated by a live event or by tapes being played in its studio. Of course, the audible sounds being generated in its studio would be generated by a "live performance" by, for example, players of some musical instruments, singer, or talk show, or by audio tapes being played which could be of any such previous live performance. The digital signal 100 would be "broadcast" to those of the ISPs on the Internet 8 agreeing to receive that signal. Assuming that the user of the Internet radio 86 has the Internet radio 86 connected to an ISP 90 agreeing to receive the digital signal 100, tuning the Internet radio 86 to the frequency of the radio station 92 will cause the digital signal 100 to travel from the ISP 90 over the conventional telephone lines 88 to the Internet radio 86. Once the digital signal 100 is received at the Internet radio 86, the Internet radio 86 will reconvert the digital signal 100 into the original audible sounds generated live at the studio of the radio station 92 or generated by the data recorded on the audio tape played at the studio.

The Internet radio 86 comprises a microcontroller just as the telephonic device previously described does. That microcontroller is

programmed to convert the selection of a frequency in the tuner of an Internet radio 86 into a digital signal sent by the Internet radio 86 to the ISP 90 which will cause the selection of the digital signal sent by the radio station corresponding to the frequency tuned to from all of the radio digital signals received by the ISP 90.

The Internet radio 86 optionally also possesses the capability to function as a conventional radio receiving radio signals which are transmitted by conventional radio stations not connected to the Internet.

There are several advantages of this embodiment of the invention over conventional radio transmission and reception. First, it greatly reduces any problem that the radio station might face if it desires to transmit large quantities of information simultaneously. Instead of being limited to a strictly defined bandwidth in airwaves that are increasingly crowded and subject to atmospheric disturbances and interference from other transmission sources, the radio station can transmit over a "dedicated" bandwidth of the Internet to certain select users, with the size of the bandwidth only subject to its economic capacity to pay for it and the overall capacity of the Internet. Atmospheric disturbances for the most part need no longer be feared for their potential interference with quality transmission and reception. Second, the limited range of its transmission by atmospheric means due to rapid signal attenuation is replaced by the transmission through the Internet which is only limited by the geographical extent of the Internet and the ISPs to which it wishes or

is able to transmit the signal. On the other hand, this embodiment of the invention makes the Internet radio 86 not portable as it must be connected to conventional telephone lines 88, where a conventional radio can be easily carried about, being operable in wireless mode. This feature is, of course, balanced by the fact that an Internet radio 86 can receive signals from any and all stations transmitting to its ISP largely independent of weather conditions, (excluding perhaps solar flares, or other atmospheric electromagnetic disturbances) be they a few miles away or halfway around the globe, whereas conventional radios, excluding shortwave models, are strictly limited in the stations that can be received to those within a comparatively short distance.

Figure 7 shows a seventh embodiment of the invention. This embodiment differs from the sixth embodiment in that the radio station 102 in this embodiment is not connected to its ISP 104 through conventional telephone lines, but relies on the radio waves 106 of its conventional radio transmission to connect with its ISP 104. Alternatively, the radio station 102 may broadcast at frequencies normally used for cellular telephones or at any other frequencies that may prove convenient.

The embodiment, of course, assumes that the ISP 104 is capable of receiving wireless communications as well as communications over the conventional telephone lines. Once the radio waves 106 of the conventional analog radio transmission of the radio station 102 are

received by the ISP 104, the radio waves 106 are converted to digital signals 108 which are sent over the Internet 8 as in the sixth embodiment and received by those ISPs 110 agreeing to receive the digital signals 108 corresponding to the radio broadcast of radio station 102. As in the sixth  
5 embodiment, the Internet radio 112 will receive the digital signals 108 corresponding to the radio broadcast of the radio station 102 when it is tuned to the frequency of the radio station 102. The seventh embodiment of the invention saves the radio station 102 the additional expense of being connected to the ISP 104 through conventional telephone lines and any  
10 associated equipment needed to convert its otherwise wireless radio broadcast into a digital signal to be sent over telephone lines to the ISP 104.

Of course, the advantage of greatly increased bandwidth available to the radio station for broadcasts by digital signals sent to its  
15 ISP may be somewhat affected by possible interference from other transmission sources and by atmospheric disturbances because of the wireless transmission between the radio station 102 and its ISP 104. It should be noted that these factors may also cause degradation of analog and digital radio signals in general, cellular telephone signals, and other  
20 analog and digital wireless transmissions. However, if wireless transmissions are sent in digital form such degradation may not prevent successful reception of transmissions due to the availability of numerous and effective error correction schemes. These factors can also be

minimized if the ISP 104 is located in proximity to the radio station 102 and is able to receive signals over a large bandwidth, even though such a bandwidth may be impossible to employ if wireless transmission is desired directly between the radio station 102 and the user of the Internet radio  
5 112.

Figure 8 shows an eighth embodiment of the invention. The embodiment differs from the sixth embodiment in that the ISP 120 of the user of the Internet radio 124 is not connected to the Internet radio 124 by conventional telephone lines. Instead, wireless transmission 122 is relied  
10 upon from the ISP 120 to the Internet radio 124. However, as in the sixth embodiment, the radio station 114 sends out a digital signal 126 over conventional telephone lines 116 to its ISP 118, which, in turn, relays that digital signal over the Internet 8 to the ISP 120. The ISP 120 must have the capability of transmitting that digital signal as a wireless transmission  
15 122, intended for the Internet radio 124. The Internet radio 124 in this embodiment must have the capability of receiving the wireless transmission 122, similarly to a conventional radio, in addition to or instead of the capability of receiving digital signals 100 over conventional telephone lines 88 possessed by Internet radio 86 in the sixth embodiment  
20 of the invention. The characteristics of wireless transmissions, as described in the seventh embodiment of the invention in connection with the radio station 102 and its ISP 104, apply in an analogous fashion to the Internet radio 124 and its ISP 120.



The advantage of this embodiment of the invention over the sixth embodiment of the invention is the result that the Internet radio 124 becomes truly portable as a conventional radio is. The Internet radio 124 may be portably carried by a person or may be installed in an automobile, ship, train, airplane, or other means of transportation. In contrast to a conventional radio, however, the limit of its portability is not the strength of the broadcast from the radio station 114, but rather the strength of the wireless transmission 122 from its ISP 120 and the medium by which that wireless transmission 122 is conducted to the Internet radio 124, either being wholly atmospheric or using one or more satellites.

Figure 9 shows a ninth embodiment of the invention. This embodiment differs from the sixth embodiment in that both the radio station 126 and the ISP 128 of the user of the Internet radio 130 are transmitting in a wireless mode to the ISP 132 of the radio station 126 and the Internet radio 130, respectively. As previously indicated, the advantage of greatly increased bandwidth available to the radio station 126 in the sixth embodiment may be somewhat affected by the abandonment of a conventional telephone line connection between the radio station 126 and the ISP 132, although, as before commented, the use of digital wireless transmissions and a proximity between the radio station 126 and the ISP 132 may largely obviate any such possible effect. As further previously indicated, the Internet radio 130 in this embodiment becomes truly portable as a conventional radio is.

In this embodiment, both the ISP 132 of the radio station 126 and the ISP 128 of the user of the Internet radio 130 must have, respectively, the capability of receiving wireless transmission and the capability of transmitting such transmission, and must have, respectively, the capability of converting wireless transmission to digital signals capable of traversing the Internet and the capability of receiving such digital signals and converting them to wireless transmission if the wireless transmissions are assumed to be analog. To the extent, however, that the wireless transmissions are digital, no conversions between analog and digital signals will be necessary. Furthermore, the Internet radio 130 must have the capability of receiving the wireless transmission from the ISP 128 similar to the wireless reception capability of Internet radio 124 in the eighth embodiment of the invention. The characteristics of wireless transmissions, as described in the seventh embodiment of the invention in connection with the radio station 102 and its ISP 104, apply in an analogous fashion to the Internet radio 130 and its ISP 128.

Figure 10 shows the tenth embodiment of the invention. This embodiment differs from the sixth through ninth embodiments of the invention in that the Internet radio 132 is no longer receiving audio data from a broadcasting radio station which is simultaneously broadcasting such audio data by conventional radio waves through the atmosphere. Instead, the source of the audio data is what may be termed an "Internet radio station" 134. Such an Internet radio station 134 would be capable

of transmitting the range of live, prerecorded, or archival radio broadcasts that a conventional radio station would, with the crucial difference that simultaneous wireless transmission would not occur. Instead, all such audio data would be channeled exclusively by conventional telephone lines

5 136 to the ISP 138 of the Internet radio station. This would produce the previously discussed advantages of greatly increased bandwidth available to the sixth embodiment of the invention, while saving the Internet radio station the expense of both the equipment and power consumption involved in conventional wireless transmission. The digital signal 140 sent out by

10 the Internet radio station 134 would, as in the sixth embodiment of the invention, be relayed over the Internet 8 to the ISP 142 of the user of the Internet radio 132, again assuming that the ISP 142 has agreed to receive the digital signal 140.

An Internet radio station 134 could optionally broadcast only

15 subject matter restricted in certain ways such, as for example, music related to a certain ethnic group, music directed only to children, or music containing no sexual references or other material objectionable to certain listeners for religious or other moral reasons.

In the tenth embodiment of the invention, the ISP 142 is

20 shown as transmitting by wireless transmission 144 data contained within the digital signal 140. As previously noted, the ISP 142 must have the capacity to produce such a wireless transmission 144 and to convert the digital signal 140 into the wireless transmission 144 if an analog wireless

transmission is used. Such a transmission 144, as previously noted, would make the Internet radio 132 truly portable in the same manner that a conventional radio is truly portable, assuming again that the Internet radio 132 can receive such wireless transmission 144. The characteristics of wireless transmissions, as described in the seventh embodiment of the invention in connection with the radio station 102 and its ISP 104, apply in an analogous fashion to the Internet radio 132 and its ISP 142. It should be understood, however, that, as in previous embodiments, the Internet radio 132 can be connected by conventional telephone lines to its ISP 142 if no wireless transmission capability of the ISP 142 exists or if the Internet radio 132 cannot receive wireless transmission.

Although the Internet radio, as previously described, has minimal differences from a conventional radio, such differences being transparent to the user, i.e., a microcontroller, an enhanced version of the Internet radio incorporating within itself many of the capabilities traditionally associated with personal computers, yet easily used by the ordinary consumer, is disclosed below. Such an enhanced Internet radio is shown in several views in Figures 11, 11A and 11B. This enhanced Internet radio 146 allows for an interactive menu of virtually unlimited audio selections, including, but not limited to, live audio broadcasts from major radio stations, historical audio, entertainment audio, educational audios, multi-casting and private custom broadcasts for specialized audiences with common interests. Internet radio 146 can also display on

its LED (Light Emitting Diode) or active matrix or passive matrix LCD (Light Crystal Display) type screen 148 media such as music lyrics and text to teach vocabulary and diction of songs or audiobooks to teach musical scores, biographical information, motion and still commercial advertising and marketing information, and motion and still graphical pictures and text to enhance the mood and listening experience.

In another embodiment of the Internet radio (not shown), the video read-out screen can also be worn as a visor sunglasses type device either separately or as a one-piece unit to provide for automatic hands-free viewing.

In general, the Internet radio can have any variety of downloading capability onto storage, the storage being fixed or removable for subsequent replaying of audio, text and image files. Examples of such storage are memory flash cards, hard, floppy, and hybrid drive combinations, standard and digital audio tapes and any other storage mediums that may present themselves. The storage device, if removable, can be used in an independent walkman type device for portable playing of the files stored. The radio can be connected to the Internet through ordinary phone lines, DSL (Digital subscriber Lines) enhanced telephone lines, Sonet, ATM (Asynchronous Transfer Mode), ONU (Optical Network Line), T1, T3 ISDN, cable television lines, and so forth. The radio can be attached to the Internet via physical wire or wireless and antennae using wireless technologies such as Spread Spectrum technology,

cellular technology, satellite technology and so forth. The enhanced Internet radio can be a portable walkman type device that can replay previously downloaded audio, text, or images or receive audio media and associated text or image files via wireless transmission. The audio and other associated files can be downloaded singly from individual servers and devices or in bulk off central databases with digitized media placed on a computer server to allow for virtually unlimited audio, image, and text files. The radio can accept user input to pay for selected audio and associated files, such as credit card information, pin number, electronic fingerprint, etc., and advertisers can play commercials to provide payment for artists, producers, actors, and studios whose music, audio, and graphics or text is transmitted to the consumer at no cost.

The enhanced Internet radio can offer musical bass and treble equalizing through hardware or software methods. It can also receive and send e-mail in all text, image, and audio forms and can offer a touch screen to provide for input. Such input capability by touch screen or other equivalent method known to those with ordinary skill in the art would optionally allow a user of an enhanced Internet radio to interact with, for example, a radio station transmitting music to which the user is listening by selecting music which the user desires to hear. Of course, in such a case the radio station would, most probably, be required to possess a server or other equivalent electronic equipment to effectively handle the potential myriad of requests from listeners. Furthermore, any capability

to handle multiple types of interaction with users would only increase the demands on such electronic equipment.

The enhanced Internet radio can also be capable of receiving standard am/fm radio broadcasts from radio stations not connected to the Internet and, as well, can be combined with other appliances, such as, for  
5 example, a house intercom.

In the particular embodiment of the enhanced Internet radio shown in Figures 11, 11A, and 11B, the touch screen 148 shows a world map which allows the user to indicate by touch a particular geographical  
10 area of the world from which he wishes to receive a broadcast. For example, in Figure 11, the user has indicated the eastern half of the United States (indicated in black). The upper part of the screen indicates the time and the radio station and particular program being listened to. There is also on the screen a touch record button 150 giving the user the  
15 capability to record the broadcast or another audio selection being played. A mute button 152 allows the user to mute a selection while it is being recorded. The source button 154 allows the user through another screen (not shown) to select a radio station or other source on the Internet or a compact disc (CD), which may be loaded into the enhanced Internet radio,  
20 as a source of audio to be played for the listener.

Of course, the CD may be of the type to which audio data can be written as well as read, and, in that case, audio obtained from the Internet may be recorded by a CD placed in the enhanced Internet radio

as it is being listened to by a user. The mode button 156 may, through other screens (not shown), allow the listener to do such things as obtain a timed record of a certain audio selection, set the time kept by the enhanced Internet radio, or adjust the bass, treble, and balance of an audio selection. The station button 158 allows a user, through other screens (not shown), to select a particular station or source on the Internet to which the user wishes to listen. The volume button 160 allows the user to adjust the volume, through other screens (not shown), showing graphically the volume level and its adjustment in real time.

Figure 11A, a side view of the enhanced Internet radio, shows a power switch 162 for turning the unit on and off, a power outlet 164 for wired operation, a CD connection 166 for connection to a CD player playing a CD external to the unit, a connection for earphones 168 to allow the user to listen to the unit through earphones, and a speaker connection 170 to allow the unit to be plugged into speakers for enhanced sound during play. Although the unit can be operated in the wired mode as previously stated, battery-powered operation is equally feasible. A side view also shows a telephone jack connection 172 so that the unit can be connected to conventional telephone lines. As previously stated, however, the unit can be operated in a wireless mode so that it connects to the Internet by wireless reception instead of through conventional telephone lines. The top view, Figure 11B, shows an eject button 174 for use in



removing a CD placed in the enhanced Internet radio for playing and/or recording purposes.

Associated with the enhanced Internet radio is an optional remote control device, controlled by either manual entry or voice entry, of which views are shown in Figures 12 and 12A. The remote control  
5 device has the capacity to search the memory of the enhanced Internet radio 146 by such categories as subject, station name, program title or location of station. The database being searched is, of course, internally stored in the memory of enhanced Internet radio 146.

10 The enhanced Internet radio may optionally be programmed with software enabling it to recognize voices, and to synthesize a voice for the purpose of responding to a limited number of voice commands. Such a capability would potentially greatly reduce the need for the optional remote control device described in the prior paragraph. For example, the  
15 user might specify by voice a certain station to which the user desires to listen, and the enhanced Internet radio would tune to that station. If the request of the user was not clear to the enhanced Internet radio, it could ask for clarification using its capability of voice synthesis. As an additional example, the user could request by voice an adjustment of the  
20 volume, bass, treble, or balance of an audio selection. The enhanced Internet radio could make a trial adjustment in response to such a request, with a voice synthesized response inquiring of the user whether the adjustment was satisfactory. For example, if the user requested that the

volume be increased, a trial adjustment could be made by the enhanced Internet radio, and the enhanced Internet radio could ask, "Is that loud enough?". Alternatively, an adjustment to the volume could be made by the enhanced Internet radio, without any subsequent voice response by the enhanced Internet radio.

The enhanced Internet radio may also be capable of converting the voice portion of a broadcast into a digital form representing text corresponding to the words spoken by the voice, assuming the enhanced Internet radio has the voice recognition capability mentioned above, and storing the digital data in its memory. The enhanced Internet radio may also be capable of storing in its memory text from text files downloaded from the Internet or received from fixed or removable storage devices. The text can be printed out either by a printer integrally contained within the enhanced Internet radio or, alternatively, the enhanced Internet radio may have a printer port to transmit the digital data corresponding to the voice portion of a broadcast or the text from one or more text files to an attached printer for print out.

The memory of the enhanced Internet radio may be large enough to contain a database of many songs categorized by genre (eg., classical, folk, pop, rock), artist, instruments used, or other classification or such database may be contained on a server connected by the Internet to the enhanced Internet radio. In such case, the user may request a list of songs classified by any of these categories to be displayed on the touch

screen 148 of the enhanced Internet radio or may request a particular song to be played. The request could be entered on the remote control device, assuming the remote control device has the capability to search the song database by the requested category or for the particular song requested.

5 Alternatively, direct voice commands to the enhanced Internet radio would be possible if the voice recognition capability of the enhanced Internet radio mentioned above exists and if the enhanced Internet radio is capable of searching its internal song database or any previously mentioned remotely stored song database by the requested category or for the

10 particular song requested.

Several alternative configurations of the enhanced Internet radio and peripheral accessories are possible.

Figure 13 shows an enhanced Internet radio 176, with earphones connected 178, and the remote control device 180.

15 Figure 14, in addition to the components shown in Figure 13, adds a set of speakers 182, 184 supported by a shelf 186 on a wall 188, which also supports the enhanced Internet radio 190.

Figure 15 shows the speakers 192, 194 mounted some distance away from the enhanced Internet radio 196 on a supporting wall.

20 The enhanced Internet radio 196 is communicating in a wireless fashion with the speakers 192, and 194.

Figure 16 shows speakers 198, 200, enhanced Internet radio 202, and the remote control device 204, but adds a unit capable of holding

multiple CDs or a hard drive 206 attached to the enhanced Internet radio 202. The enhanced Internet radio 202 is capable of reading and playing audio data stored on the CD or hard drive unit 206 or of storing audio data on the CD or hard drive unit 206.

5                    Fig. 17 shows an eleventh embodiment of the invention. In this embodiment, an Internet television 208 is connected by conventional telephone lines 210 to an ISP 212 providing Internet services to the user of the Internet television 208. A television station 214 is also connected by conventional telephone lines to 216 to ISP 218, likewise providing  
10 Internet services to the television station 214. Although the television station 214 may be a conventional television station, it may also be a private transmitter in a residential or other nonconventional location.

                    When a user of the Internet television 208 desires to select the channel of the television station 214 and view whatever video  
15 communication is then being broadcast by that television station 214, the user activates the Internet television 208, which may be battery-powered or connected to a conventional electrical outlet just like a conventional television. The user then selects the channel desired on the Internet television 208 precisely in the same manner the user would select a  
20 channel on a conventional television. Upon the channel of the television station 214 being selected, the Internet television 208 will immediately transmit in visible and audible form the broadcast of the television station 214.

The process which insures this result is as follows. The television station 214, at the same time that it generates electromagnetic waves 215, corresponding to the images and audible sounds being generated in its studio, sends out a digital signal 217 over the conventional telephone lines 216 connecting it to its ISP 218. That digital signal 217 preferably also corresponds as fully as do the electromagnetic waves 215 to the images and audible sounds being generated in the studio of the television station 214. Of course, the images and audible sounds being generated in the studio would be produced by a "live performance" of a show or by videotapes being played which could be of any such previous live performance. The digital signal 217 would be "broadcast" to those of the ISPs on the Internet 8 agreeing to receive that signal. Assuming that the user of the Internet television 208 has the Internet television connected to an ISP 212 agreeing to receive the digital signal 217, selecting the channel of the television station 214 on the Internet television 208 will cause the digital signal 217 to travel from the ISP 212 over the conventional telephone lines 210 to the Internet television 208. Once the digital signal 217 is received at the Internet television 208, the Internet television 208 will reconvert the original signal 217 into the original images and audible sounds generated at the studio of the television station 214 by a live performance or by the data recorded on the videotape played at the studio.

The Internet television 208 comprises a microcontroller just as the Internet radio 86 and the telephonic device previously described do. That microcontroller is programmed to convert the selection of a channel in the tuner of an Internet television 208 to a digital signal sent by the Internet television 208 to the ISP 212, which will cause the selection and reception by the Internet television 208 of the digital signals sent by the television station corresponding to the channel selected from all of the television digital signals received by the ISP 212.

The Internet television 208 optionally also possesses the capability to function as a conventional television receiving television signals either through wireless (atmospheric or satellite) transmission of television signals or transmission of those signals over conventional cable networks.

There are several advantages of this embodiment of the invention over conventional wireless television transmission and reception. First, it greatly reduces any problem that the television station might face if it desires to transmit large quantities of information simultaneously. Instead of being limited to a strictly defined bandwidth in airwaves that are increasingly crowded and subject to atmospheric disturbances and interference from other transmission sources, the television station can transmit over a "dedicated" bandwidth of the Internet to certain select users, with the size of the bandwidth only subject to its economic capacity to pay for it and the overall capacity of the Internet. Atmospheric

disturbances, for the most part, need no longer be feared for the potential interference with quality of transmission and reception.

Second, the limited range of transmission of the television station by atmospheric means due to rapid signal attenuation is replaced  
5 by the transmission through the Internet, which is only limited by the geographical extent of the Internet and the ISPs to which the television station wishes or is able to transmit the signal.

Fig. 18 shows a twelfth embodiment of the invention. This embodiment differs from the eleventh embodiment in that the television  
10 station 220 in this embodiment is not connected to its ISP 222 through conventional telephone lines, but rather relies on the electromagnetic waves 224 of its conventional television transmission to connect with its ISP 222.

The embodiment, of course, assumes that the ISP 222 is  
15 capable of receiving wireless communications as well as communications over the conventional telephone lines. Once the electromagnetic waves 224 of the conventional television transmission of the television station 220 are received by the ISP 222, the electromagnetic waves 224 are converted to digital signals 221 which are sent over the Internet 8 as in the eleventh  
20 embodiment and received by those ISPs 223 agreeing to receive the digital signals 221 corresponding to the television broadcast of television station 220. As in the eleventh embodiment, the Internet television 225 will receive the digital signals 221 corresponding to the television broadcast of

the television station 220 when the channel of the television station 220 is selected. By this arrangement, the television station 220 can save the expense of the use of conventional telephone lines to connect to its ISP 222 and the expense of any equipment needed to convert or otherwise  
5 place its transmission into the form of a digital signal appropriate for travel over conventional telephone lines.

Of course, the advantage of greatly increased bandwidth available to the television station for broadcasts by digital signals sent to its ISP may be somewhat affected by possible interference from other  
10 transmission sources and by atmospheric disturbances because of the wireless transmission between the television station 220 and its ISP 222. It should be noted that these factors may also cause degradation of analog and digital radio signals in general, cellular telephone signals, and other analog and digital wireless transmissions. However, if wireless  
15 transmissions are sent in digital form such degradation may not prevent successful reception of transmissions due to the availability of numerous and effective error correction schemes. These factors can also be minimized if the ISP 222 is located in proximity to the television station 220 and is able to receive signals over a large bandwidth, even though  
20 such a bandwidth may be impossible to employ if wireless transmission is desired directly between the television station 220 and the user of the Internet television 225.



Fig. 19 shows a thirteenth embodiment of the invention.

This embodiment differs from the eleventh embodiment in that the Internet television 226 is not connected to its ISP 228 by conventional telephone lines, but, rather, receives a wireless signal 230 from its ISP 228. This, of course, assumes that the ISP 228 is equipped to send out such a wireless signal 230 and to convert the digital signal 232, which it receives from the Internet 8 and which ultimately originated with the television station 234 to such a wireless signal 230. The Internet television 226 in this embodiment must have the capability of receiving the wireless signal 230, in addition to or instead of the capability of receiving digital signals 217 over conventional telephone lines 210 possessed by the Internet television 208 in the eleventh embodiment of the invention. The characteristics of wireless transmissions, as described in the twelfth embodiment of the invention in connection with the television station 220 and its ISP 222, apply in an analogous fashion to the Internet television 226 and its ISP 228. The thirteenth embodiment produces the advantage of a portable Internet television 226 since the Internet television 226 is no longer dependent on a connection to the conventional telephone lines, but can receive a wireless transmission 230 from its ISP 228.

Fig. 20 shows a fourteenth embodiment of the invention. This embodiment differs from the eleventh embodiment in that both the ISP 236 of the television station 238 and the ISP 240 of the user of the Internet television 242 are not connected to the television station 238 and

the Internet television 242 respectively, by conventional telephone lines. Rather, the ISP 236 receives the conventional television transmission 244 of the television station 238 instead, and the Internet television 242 receives a wireless transmission 246 from the ISP 240. The characteristics of the twelfth and thirteenth embodiments of the invention are combined in this embodiment. As previously indicated, the television station 238 saves any expense associated with sending out its separate digital signal over conventional telephone lines to its ISP 236. However, the advantage of greatly increased bandwidth available to the television station 238 in the eleventh embodiment may be somewhat affected by the abandonment of a conventional telephone line connection between the television station 238 and the ISP 236, although, as before commented, the use of digital wireless transmissions and a proximity between the television station 238 and the ISP 236 may largely obviate any such possible effect. Furthermore, as previously noted, the Internet television 242 is rendered portable as it no longer depends on a digital signal transmitted to it over conventional telephone lines, but rather receives the wireless transmission 246 sent to it by its ISP 240. Finally, the characteristics of wireless transmissions, as described in the twelfth embodiment of the invention in connection with the television station 220 and its ISP 222, apply in an analogous fashion to the Internet television 242 and its ISP 240.

Fig. 21 shows a fifteenth embodiment of the invention. In this embodiment, an Internet television 248 is capable of receiving a

wireless transmission 250 from its ISP 252. The ISP 252 has converted a digital signal 254 which the ISP 252 has received from the Internet 8. That digital signal 254 ultimately has originated with a source of video information 256 connected to the Internet 8 through conventional telephone lines 258 and its ISP 260. The source of video information or "Internet television station" 256 can in all respects be the same as a conventional television station, except that the source of video information 256 has no capability of atmospheric or other wireless transmission of the video information which it generates. It thus only has the capability to broadcast any video information, which it has previously stored or creates on a live basis, through the Internet or other computer network, but not through atmospheric or other wireless transmission.

An Internet television station 256 could optionally broadcast only subject matter restricted in certain ways such, as for example, television programs related to a certain ethnic group, television programs directed only to children, or television programs containing no sexual references or other material objectionable to certain listeners for religious or other moral reasons.

The wired connection of the Internet television station would produce the previously discussed advantages of greatly increased bandwidth available to the eleventh embodiment of the invention, while saving the Internet television station the expense of both the equipment and power consumption involved in conventional wireless transmission. The

digital signal 254 sent out by the Internet television station 256 would, as in the eleventh embodiment of the invention, be relayed over the Internet 8 to the ISP 252 of the user of the Internet television 248, again assuming that the ISP 252 has agreed to receive the digital signal 254. The characteristics of wireless transmissions, as described in the twelfth embodiment of the invention in connection with the television station 220 and its ISP 222, apply in an analogous fashion to the Internet television 248 and its ISP 252, and also render the Internet television 248 portable, as the Internet televisions receiving wireless transmissions in previous embodiments of the invention were portable. It should be understood, however, that, as in previous embodiments, the Internet television 248 can be connected by conventional telephone lines to its ISP 252 if no wireless transmission capability of the ISP 252 exists or if the Internet television 248 cannot receive wireless transmission.

Fig. 22 shows a portion of the sixteenth embodiment of the invention. This embodiment differs from the eleventh embodiment of the invention in that the television 261 does not comprise an internal microcontroller as the eleventh embodiment of the invention does. Instead, a microcontroller is contained within an external set top box 263 and, thus, the television 261 itself is, in all respects, a conventional television. The microcontroller in the set top box 263 performs the same function with respect to the television 261 as the microcontroller in the

eleventh embodiment of the invention performed with respect to the Internet television 208.

Although the Internet television, as previously described, has minimal differences from a conventional television, such differences being transparent to the user, i.e., a microcontroller, an exemplary enhanced version of the Internet television incorporating within itself many of the capabilities traditionally associated with personal computers, yet easily used by the ordinary consumer, is disclosed below. Such an enhanced Internet television is included in Fig. 23 which shows an enhanced Internet television 262 and a remote control device 264 to control the enhanced Internet television 262 in a remote fashion. The enhanced Internet television allows for an interactive menu of virtually unlimited video selections, including, but not limited to, live television broadcasts from major television networks, cable TV, satellite TV, historical videos, entertainment videos, educational videos, multi-casting, and private or custom broadcasts for specialized audiences with common interests.

The Internet television can also display on a LED (Light Emitting Diode) or LCD (Liquid Crystal Display), for example, active matrix or passive matrix, type screen media such as music lyrics and text to teach vocabulary and diction of songs or audio books, musical notes to teach scores, biographical information, motion and still commercial

advertising and marketing information, and motion and still images and text.

In another embodiment of the enhanced Internet television (not shown), the video screen can also be worn as a visor sunglasses type device, either separately or as a one-piece unit to provide for automatic hands-free viewing.

The enhanced Internet television can have any variety of downloading capability onto storage, the storage being fixed or removable for subsequent replaying of video files combined with soundtrack and, possibly, text. Examples of such storage are memory flash cards, hard, floppy, and hybrid drive combinations, standard and digital videotapes and any other storage media that present themselves. The enhanced Internet television can be connected to the Internet or other computer network through ordinary telephone lines, DSL (digital subscriber lines), enhanced phone lines, Sonet, ATM (Asynchronous transfer mode), ONU (Optical Network Line), T1, T3, ISDN, cable TV lines, and so forth. The enhanced Internet television can be attached to the Internet or other computer networks by physical wire or wireless antenna using wireless technology such as spread spectrum technology, cellular technology, satellite technology, and so forth. The enhanced Internet television may be a portable walkman type device that can replay previously downloaded video files with audio soundtrack and possibly, text, or receive such audio/video/text media via wireless transmission. Removable storage

devices can be used to store any audio/video/text files played on a portable walkman type enhanced Internet television. The audio/video/text files can be downloaded singularly from individual servers and devices or in bulk off central databases with digitized media placed on a computer server to  
5 allow for virtually infinite storage of such media.

The enhanced Internet television can accept user input to pay for selected audio/video/text files such as credit card information, pin numbers, fingerprint I.D. or other means, and advertisers can play commercials to provide payment for artists, producers, actors, and studios  
10 whose audio/video/text files are played to the consumer at no cost. The enhanced Internet television can provide color, contrast, and tint adjustments to video reception, and bass, balance, and treble equalizing to the associated soundtrack through hardware or software methods.

The enhanced Internet television can also receive and send  
15 e-mail in all text, audio, and video forms and can offer a touch screen, keyboard, or other remote control device, including, for example, voice control, to provide input and control of the enhanced Internet television. This input and control function can be used, analogously to the input capability of the enhanced Internet radio, to allow the user of an enhanced  
20 Internet television to interact with, for example, a television station transmitting a television broadcast to a user. The potential for such interaction is enormous, including any type of interaction that may be embodied in electromagnetic signals transmitted from the user to the

television station, and responsive signals of the same type from the television station to the user. Such possibilities include, for example, voting by users on various questions presented during a broadcast, responses to a fundraising or shop at home program, or the selection by  
5 users from multiple choices of plots for television shows. Such interactive possibilities may, for example, be by voice, video, text, or other modes of communication. Of course, television stations offering such interactive capabilities to viewers will require electronic and computing equipment to handle the data transmission and reception requirements for multiple users  
10 with perhaps multiple types of requests.

The enhanced Internet television may also be capable of receiving standard television broadcasts from television stations not connected to the Internet and, as well, may be combined with other appliances, such as, for example, a house intercom.

15 The enhanced Internet television may optionally be programmed with software enabling it to recognize voices, and to synthesize a voice for the purpose of responding to a limited number of voice commands. Such a capability would potentially greatly reduce the need for the optional remote control device described previously. For  
20 example, the user might specify by voice a certain station to which the user desires to listen, and the enhanced Internet television would tune to that station. If the request of the user was not clear to the enhanced Internet television, it could ask for clarification using its capability of



voice synthesis. As an additional example, the user could request by voice an adjustment of the volume, color, contrast, tint, bass, treble, or balance of a television broadcast. The enhanced Internet television could make a trial adjustment in response to such a request, with a voice synthesized response inquiring of the user whether the adjustment was satisfactory. For example, if the user requested that the volume be increased, a trial adjustment could be made by the enhanced Internet television, and the enhanced Internet television could ask, "Is that loud enough?". Alternatively, an adjustment to the volume could be made by the enhanced Internet television, without any subsequent voice response by the enhanced Internet television.

The enhanced Internet television may also be equipped with a memory and programmed with software capable of converting the video image at any instant shown on the television screen into digital form capable of being stored in the memory. The software may also be capable of voice recognition, as mentioned above, and capable of converting the voice portion of a broadcast into a digital form, representing text corresponding to the words spoken by the voice, which can be stored in the memory. The enhanced Internet television may also be capable of storing in its memory text from text files downloaded from the Internet or received from fixed or removable storage devices. Such video image or such text corresponding to a text file or the voice portion of a broadcast may be printed out either by a printer integrally contained within the

enhanced Internet television or, alternatively, the enhanced Internet television may have a printer port to transmit the digital data corresponding to the video image or the voice portion of a broadcast or the text from one or more text files to an attached printer for print out.

5                   A database of many television broadcasts categorized by genre (eg., news, documentary, situation comedy, drama), actor, television network, or other classification may be contained on a server connected by the Internet to the enhanced Internet television. In such a case, the user may request a list of television broadcasts classified by any  
10 of these categories to be displayed on the LED or LCD type screen of the enhanced Internet television or may request a particular television broadcast to be played. The request could be entered on the remote control device, assuming the remote control device has the capability to search the television broadcast database by the requested category or for  
15 the particular television program requested. Alternatively, direct voice commands to the enhanced Internet television would be possible if the voice recognition capability of the enhanced Internet television mentioned above exists and if the enhanced Internet television is capable of searching the television broadcast database by the requested category or for the  
20 particular television program requested.

Several alternative configurations of the enhanced Internet television and peripheral accessories are possible.

Fig. 24 shows an enhanced Internet television 266 with wall-mounted speakers 268, 270 and a remote control device 272.

Fig. 25 shows an enhanced Internet television 274 with free-standing speakers 276, 278 held on a shelf 280 projecting from a wall 282. In addition, a remote control device 284 for input and control of the enhanced Internet television is also shown.

Fig. 26 shows an enhanced Internet television 286 with wall-mounted speakers 288, 290 and a remote control device 292. In addition, compact disc reader or hard drive 294 is attached to the enhanced Internet television 286. Compact disc reader or hard drive 294 is capable of reading and/or storing video files with associated soundtrack to be played or recorded by the enhanced Internet television 286.

It should be understood that all references to the Internet herein are meant to be exemplary only since this invention will allow telephonic or other data communications over other computer networks than the Internet such as, for example only, Bitnet, local area networks (LANs), and wide area networks (WANs) by analogous methods well known to those with ordinary skill in the art. It should also be understood that music or other sounds as well as the human voice may be transmitted over the telephonic devices contemplated herein, just as conventional telephones can transmit a variety of sounds. It should also be understood that when we have referred to conventional telephone lines connecting the telephones or any of the other devices in any one of the embodiments

above to either an ISP or telephone switching equipment, such conventional telephone lines can include high capacity lines, such as, for example, a T1 line, a line primarily carrying cable television (with or without a cable modem), a Digital Subscriber Line (DSL), or an ISDN  
5 line, which will allow many telephones or any of the other devices to be connected to the ISP or switching equipment over one high capacity line. This can be done so long as a network server, which is a dedicated computer, or other equivalent device acts as an interface between the high capacity line and the individual telephones. Finally, all references to a  
10 microcontroller should be understood as being exemplary only since any programmable electronic device will serve the purpose contemplated by this invention just as effectively.

It should also be understood that, in the sixth through tenth embodiments of the invention, the radio station to which the user of an  
15 Internet radio is listening may, optionally, decide to eliminate the need for an ISP interposed between it and the Internet through the use, at the radio station, of a server or equivalent electronic equipment normally used by ISPs to connect their customers to the Internet. The radio station, in such a case, would be connected directly to the Internet without the use of an  
20 ISP and would, thus, become its own ISP.

An analogous variation on the eleventh through sixteenth embodiments of the invention would result from a television station

dispensing with an ISP and becoming its own ISP by the installation of the necessary servers or equivalent electronic equipment.

It should also be understood that in the event multiple devices of various kinds similar to those described above are all located in one residence or building and are all connected to the Internet such as, for example, telephonic devices, Internet radios, and Internet televisions, they may be connected to the Internet through one master control unit which will receive one data stream from the Internet for all these devices and direct the appropriate portion of the data stream to the appropriate device. The use of the master control unit to connect to the Internet will obviate the otherwise existing need for each device to be independently connected to the Internet.

While preferred embodiments have been described herein, it will be understood by those with ordinary skill in the art that various modifications, changes, or alterations may be made to the invention disclosed and described herein without departing from its scope or its equivalent as claimed in the appended claims. For instance, it may easily be imagined that one of the telephonic devices described herein may be connected to more than one computer network simultaneously upon suitable programming of its microcontroller or that the telephone switching equipment described in connection with Fig. 3 may be connected to and allow communication on more than one computer network simultaneously.

Other modifications too numerous to mention will easily occur to one of ordinary skill in the art.

What is claimed is:

1. A device for receiving digital signals corresponding to at least video communication from at least one source of video communication and causing a user of said means to sense said video communication, said  
5 device comprising:  
a means for selecting a source from said at least one source; and  
a means for converting said digital signals into said video communication;  
said device for receiving digital signals being connected to at least one  
computer network, said digital signals traveling over said at least one  
10 computer network.
2. A device for receiving digital signals as claimed in Claim 1,  
wherein said connection to said at least one computer network comprises  
conventional telephone lines and a provider of service with respect to said  
at least one computer network.
- 15 3. A device for receiving digital signals as claimed in Claim 1,  
wherein said connection to said at least one computer network comprises  
a wireless connection between said means for receiving digital signals and  
a provider of service for said at least one computer network.

4. A device for receiving digital signals as claimed in Claim 1,  
wherein said at least one source comprises a television station.

5. A device for receiving digital signals as claimed in Claim 4,  
wherein said television station is connected to said at least one computer  
5 network by conventional telephone lines and a service provider for said at  
least one computer network.

6. A device for receiving digital signals as claimed in Claim 4,  
wherein said television station is connected to said at least one computer  
network by wireless communication with a service provider for said at  
10 least one computer network.

7. A device for receiving digital signals as claimed in Claim 4,  
wherein said television station transmits television signals by wired means  
only, said wired means consisting of said at least one computer network.

8. A device for receiving digital signals as claimed in Claim 7,  
15 wherein said television station transmits television broadcasts of restricted  
content.



9. A device for receiving digital signals as claimed in Claim 7,  
wherein said television station transmits television broadcasts directed to  
a limited audience.

10. A device for receiving digital signals as claimed in Claim 1,  
5 wherein said at least one source comprises a means for storing said video  
communication.

11. A device for receiving digital signals as claimed in Claim 1,  
wherein said means for receiving digital signals further comprises a LED  
(Light Emitting Diode) or active matrix or passive matrix LCD (Liquid  
10 Crystal Display) screen.

12. A device for receiving digital signals as claimed in Claim 1,  
wherein said device for receiving digital signals further comprises a means  
for recording said video communication.

13. A device for receiving digital signals as claimed in Claim 1,  
15 wherein said device for receiving digital signals further comprises  
earphones and speakers.

14. A device for receiving digital signals as claimed in Claim 1, wherein said device for receiving digital signals further comprises a means for controlling contrast, tint and brightness of said video communication.

15. A device for receiving digital signals as claimed in Claim 1,  
5 wherein said device for receiving digital signals further comprises a means for searching, by at least one criterion, a database contained within said means for receiving digital signals.

16. A device for receiving digital signals as claimed in Claim 1,  
10 wherein said device for receiving digital signals further comprises a means for storage of said video communication.

17. A device for receiving digital signals as claimed in Claim 1, wherein said video communication comprises images and associated soundtrack.

18. A device for receiving digital signals as claimed in Claim 1,  
15 wherein said device for receiving digital signals further comprises:

a means for entry of input to be sent to said source; and  
a means for converting said input to digital signals to be transmitted to said source over said at least one computer network.

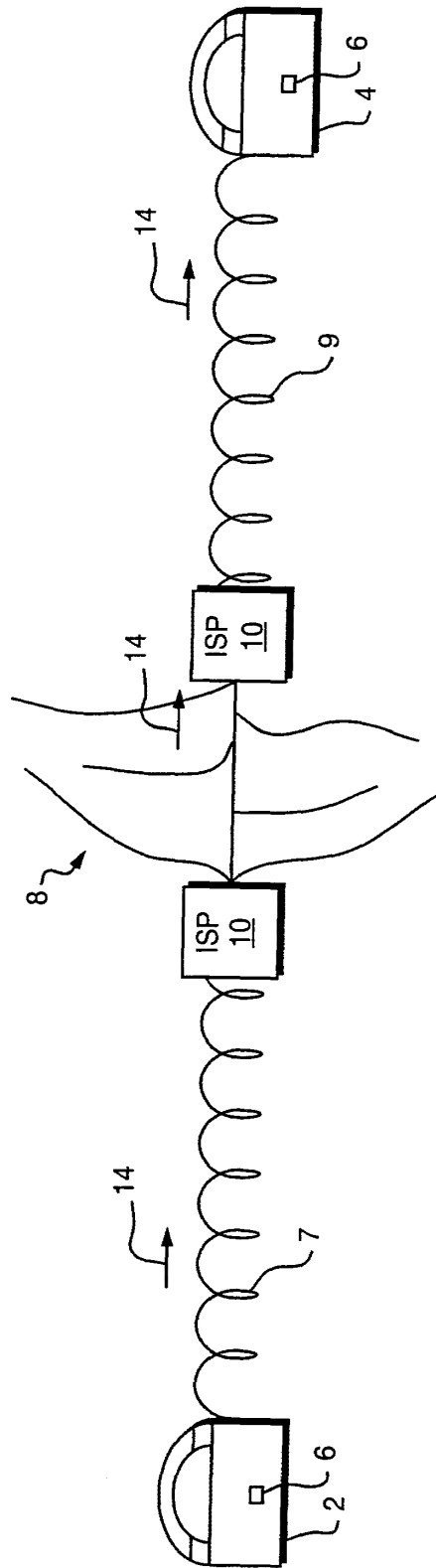


FIG. 1

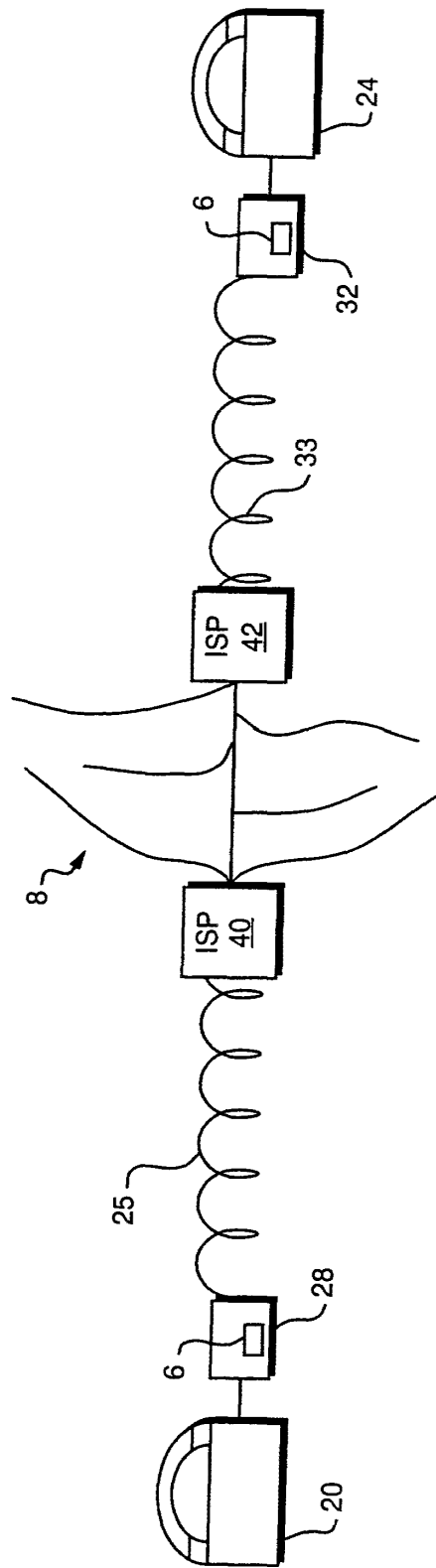


FIG. 2

3/29

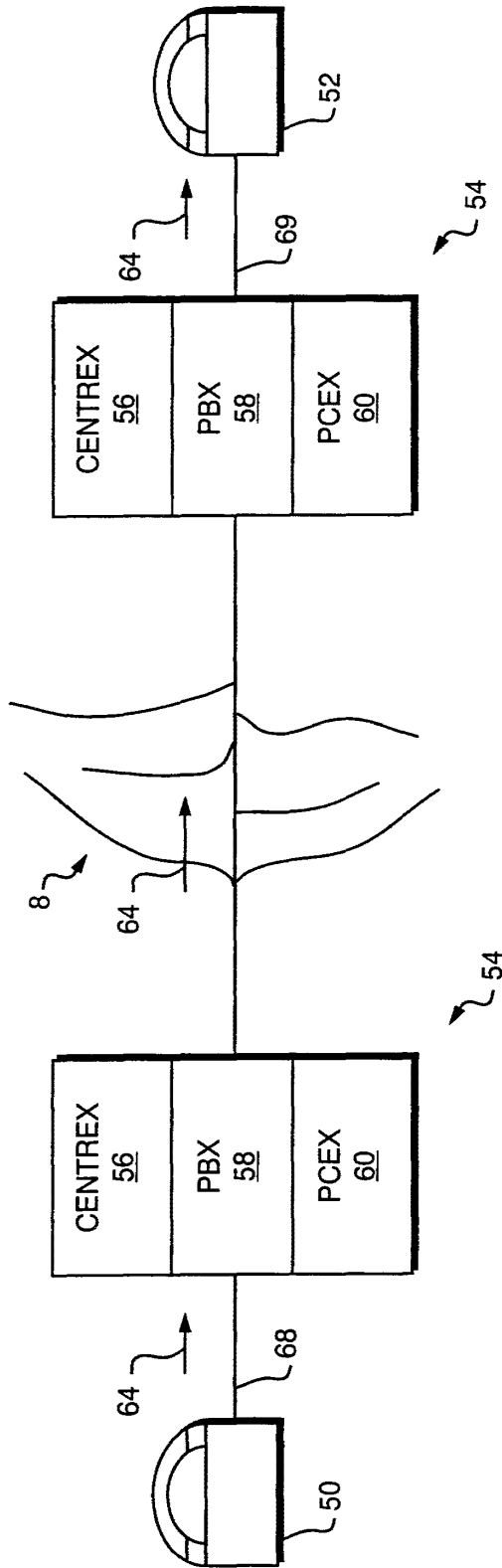


FIG. 3

4/29

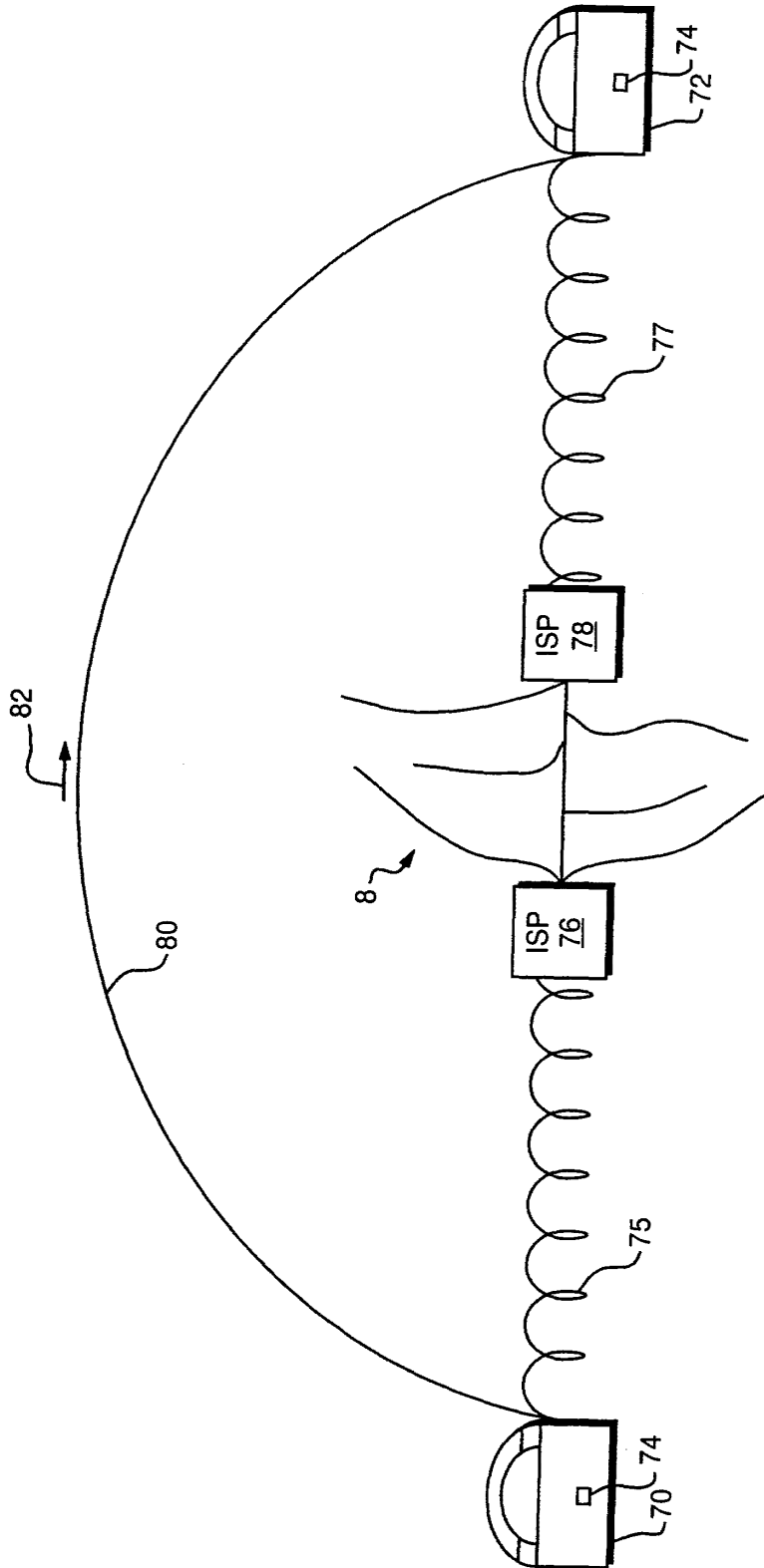


FIG. 4

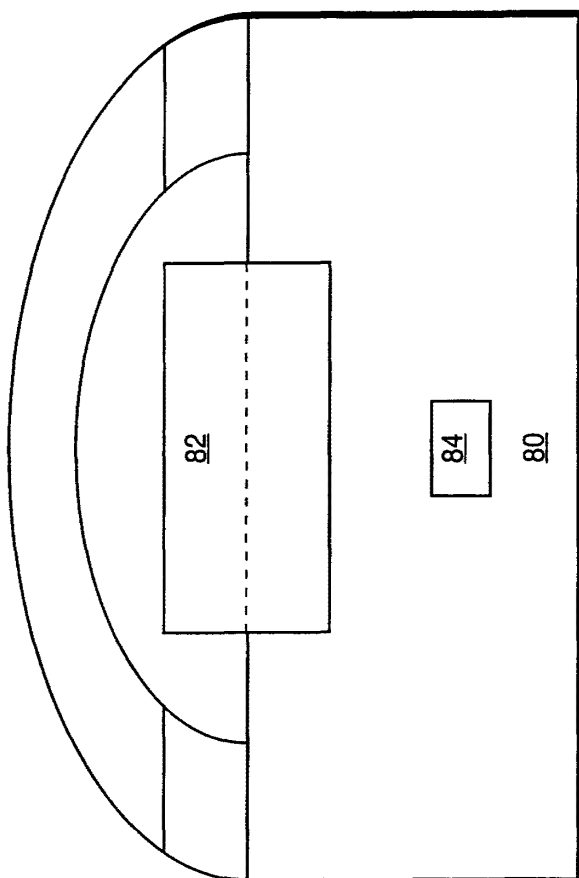


FIG. 5

6/29

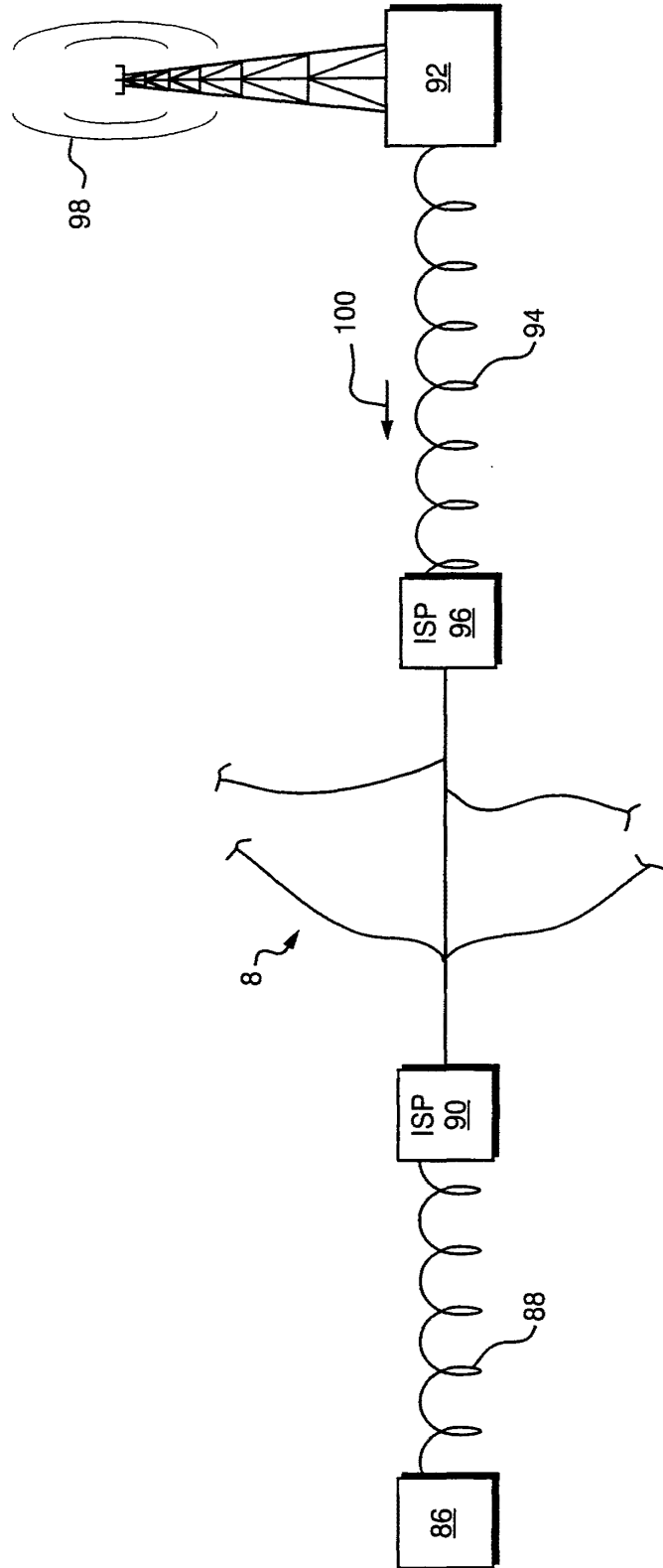
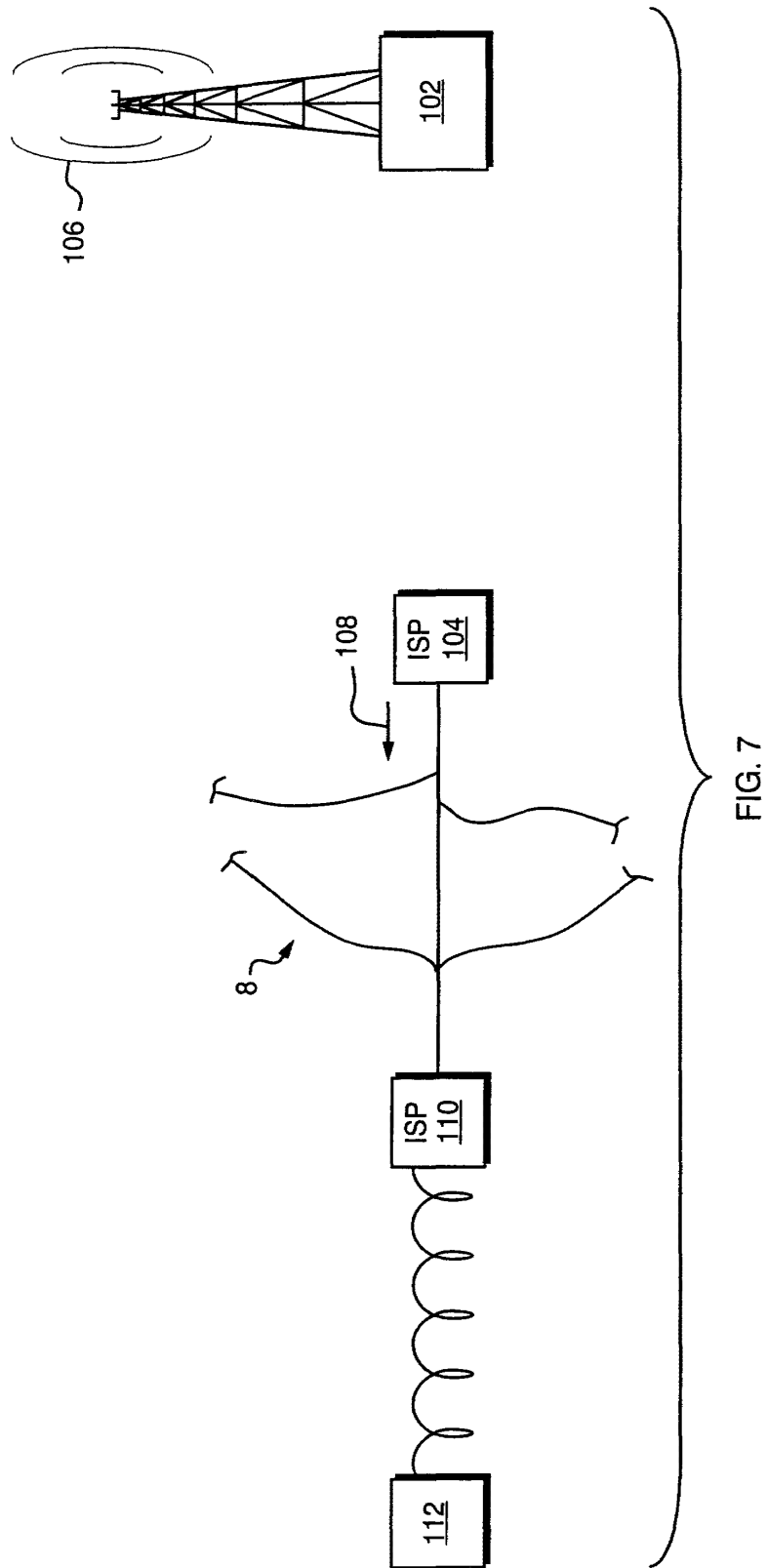


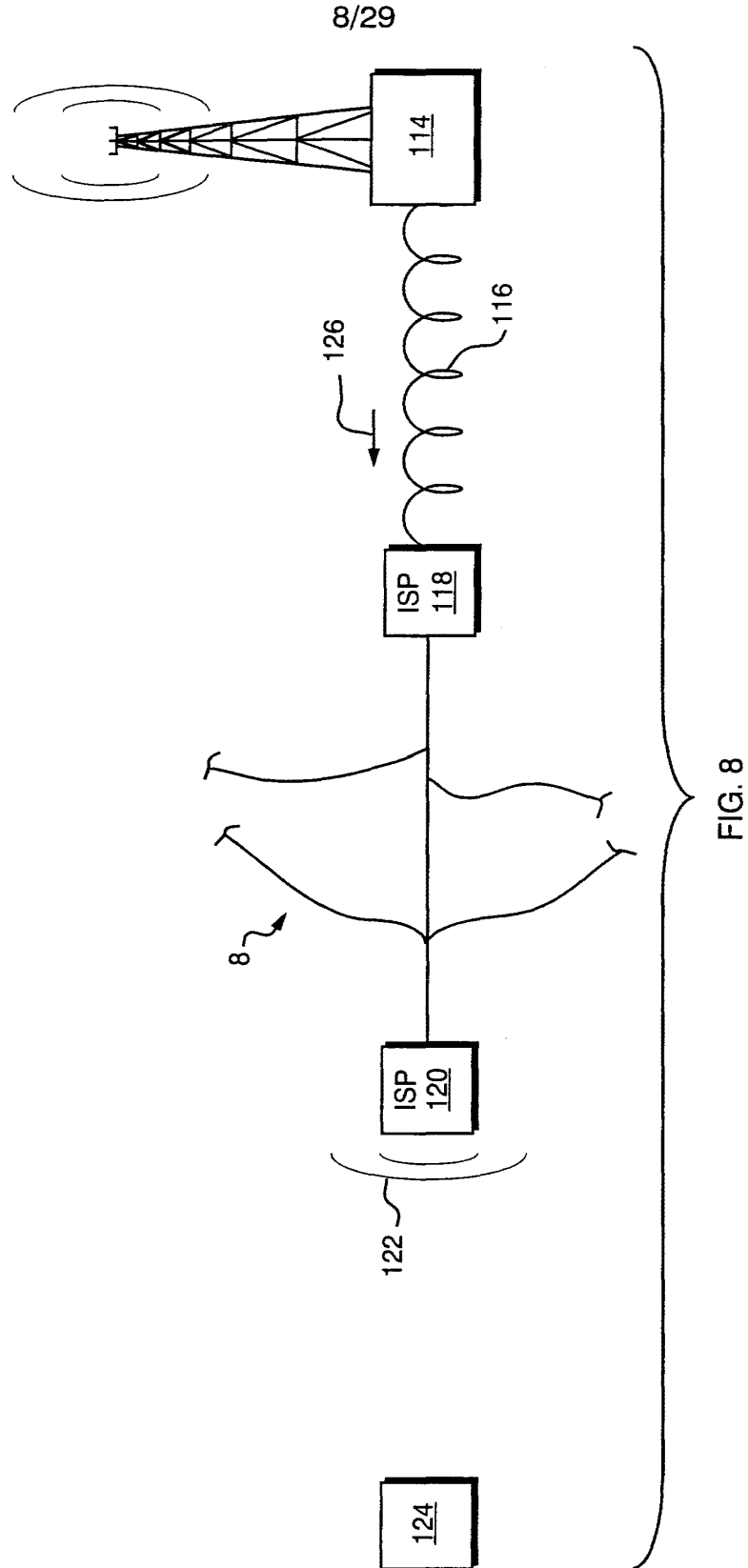
FIG. 6

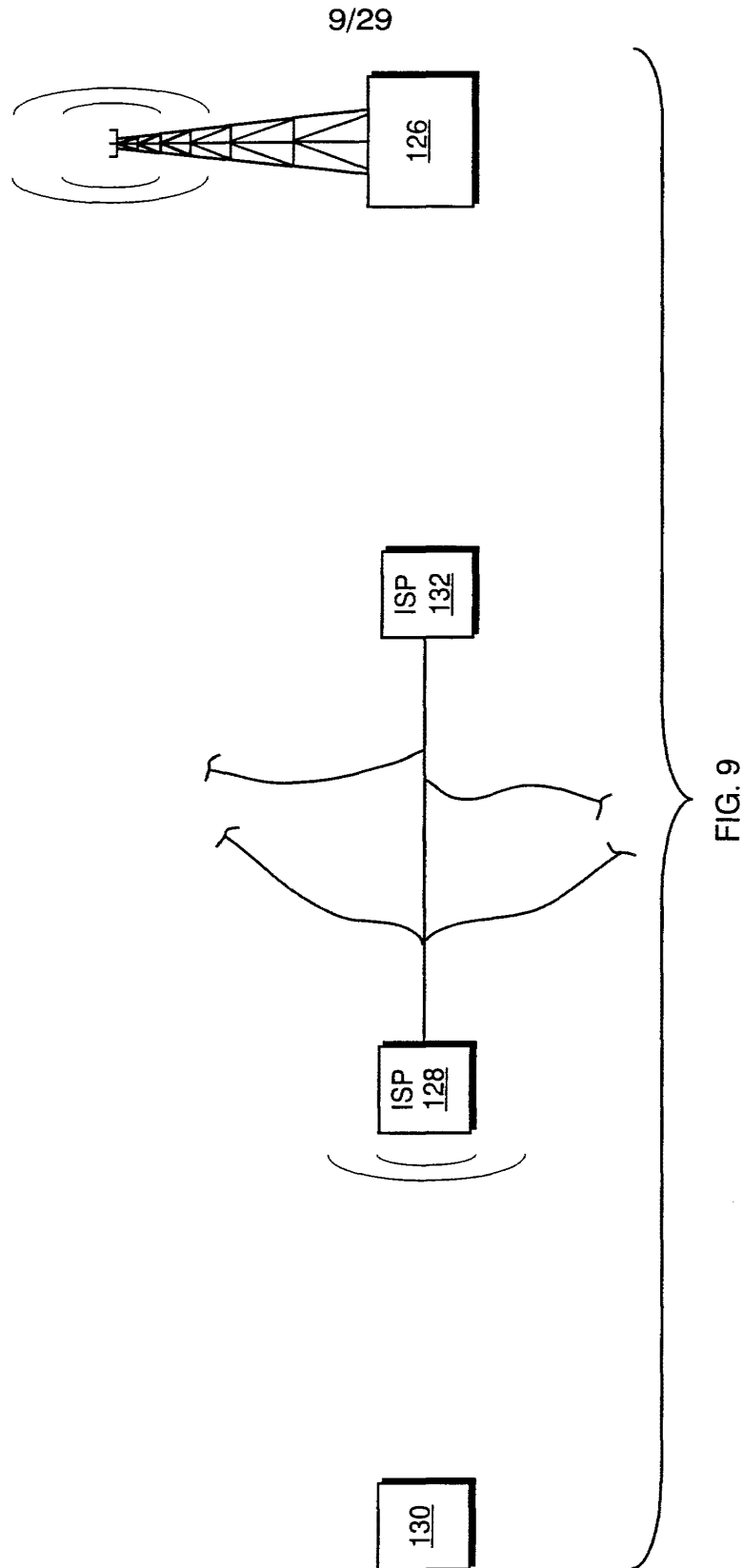


7/29



SUBSTITUTE SHEET (RULE 26)





10/29

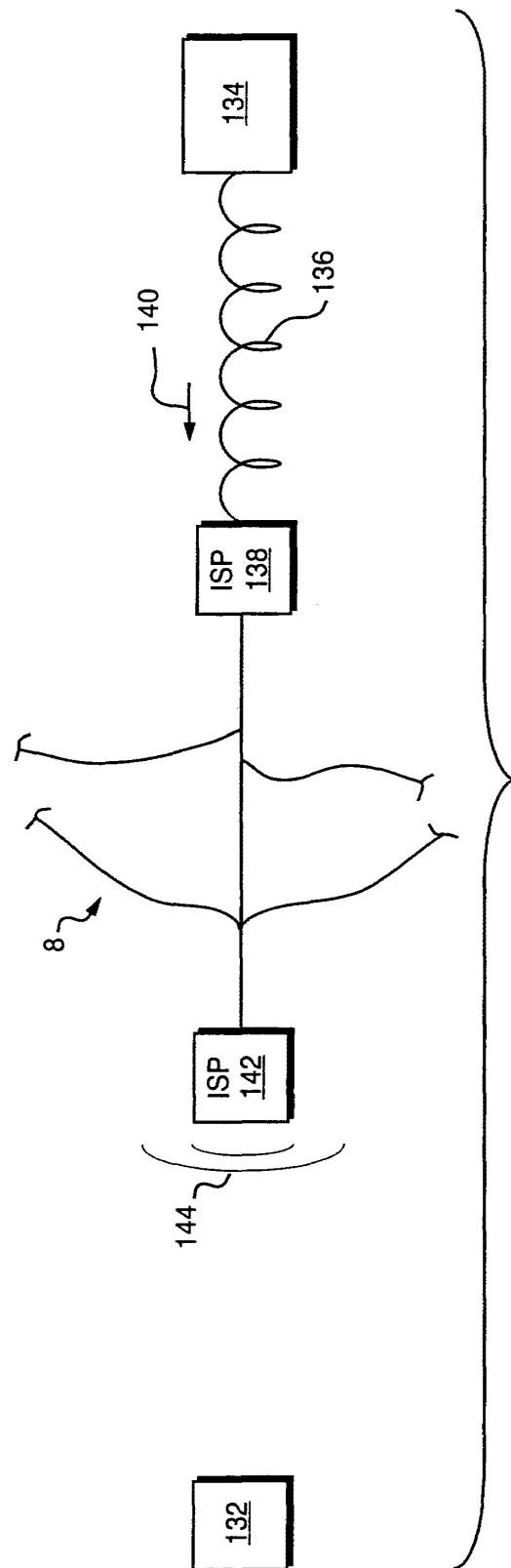


FIG. 10

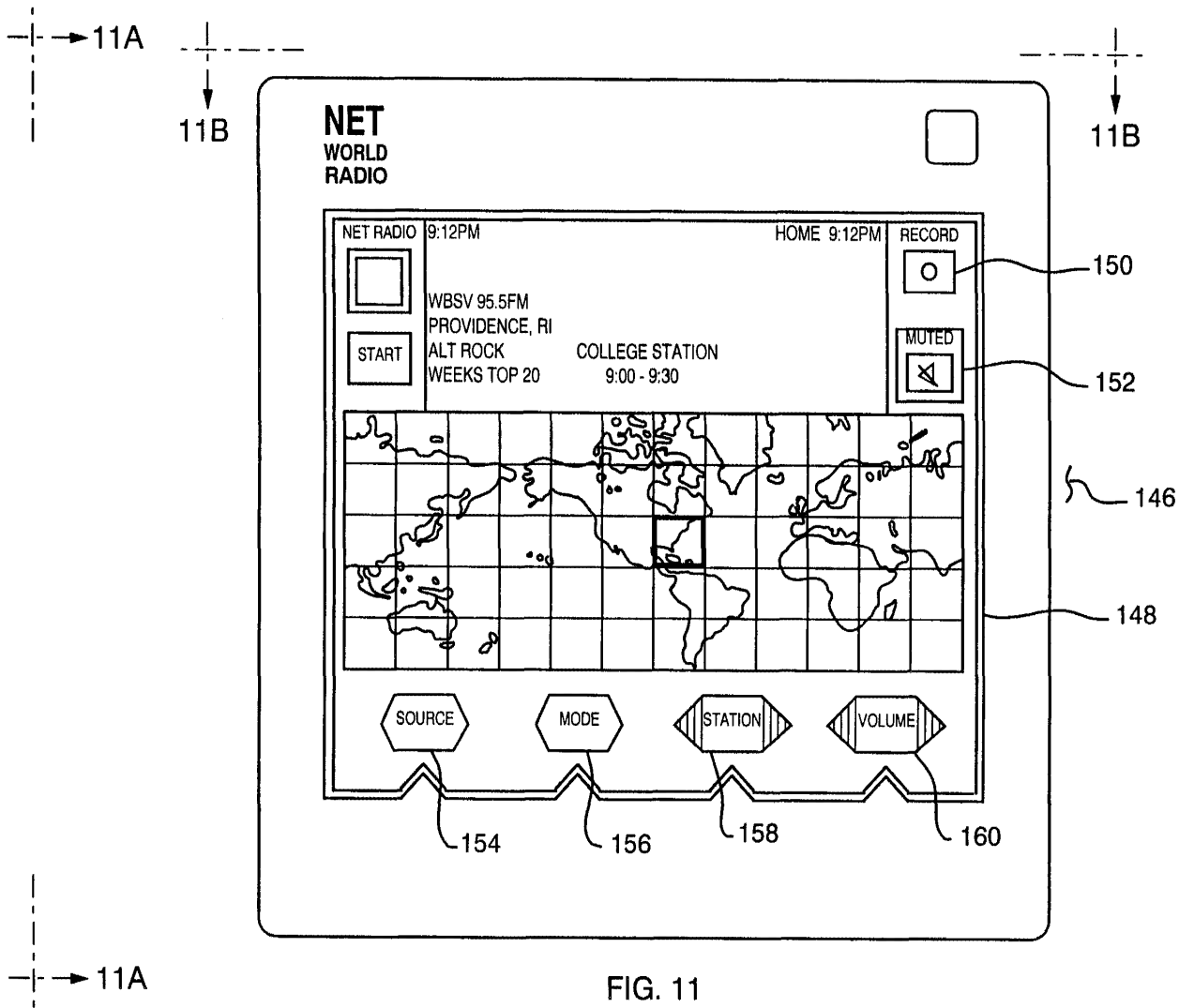


FIG. 11

12/29

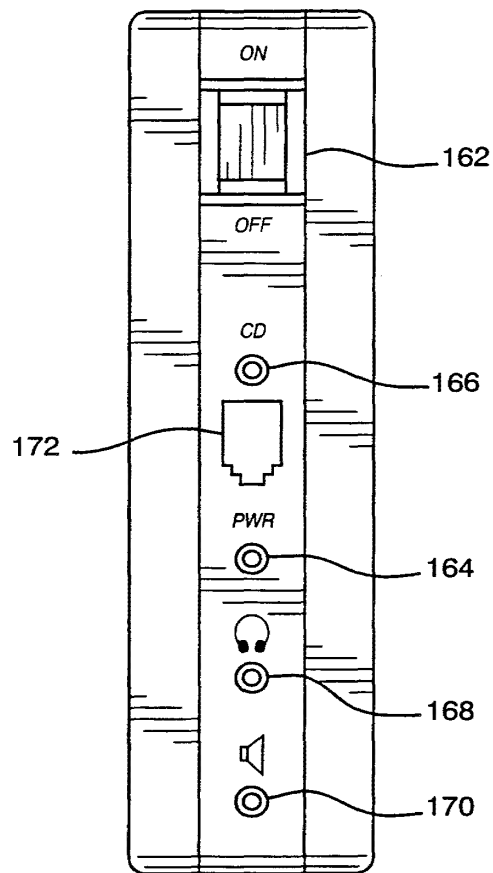


FIG. 11A

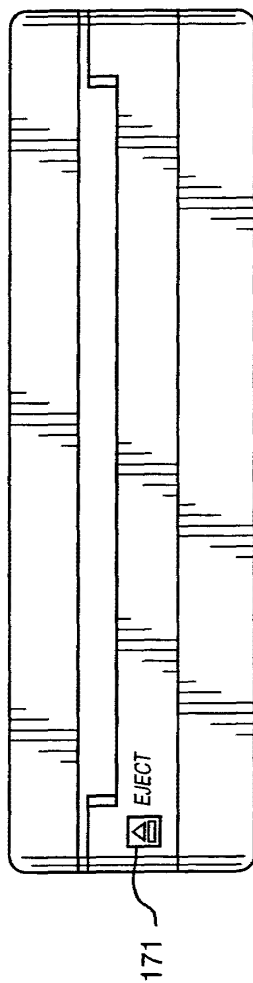


FIG. 11B

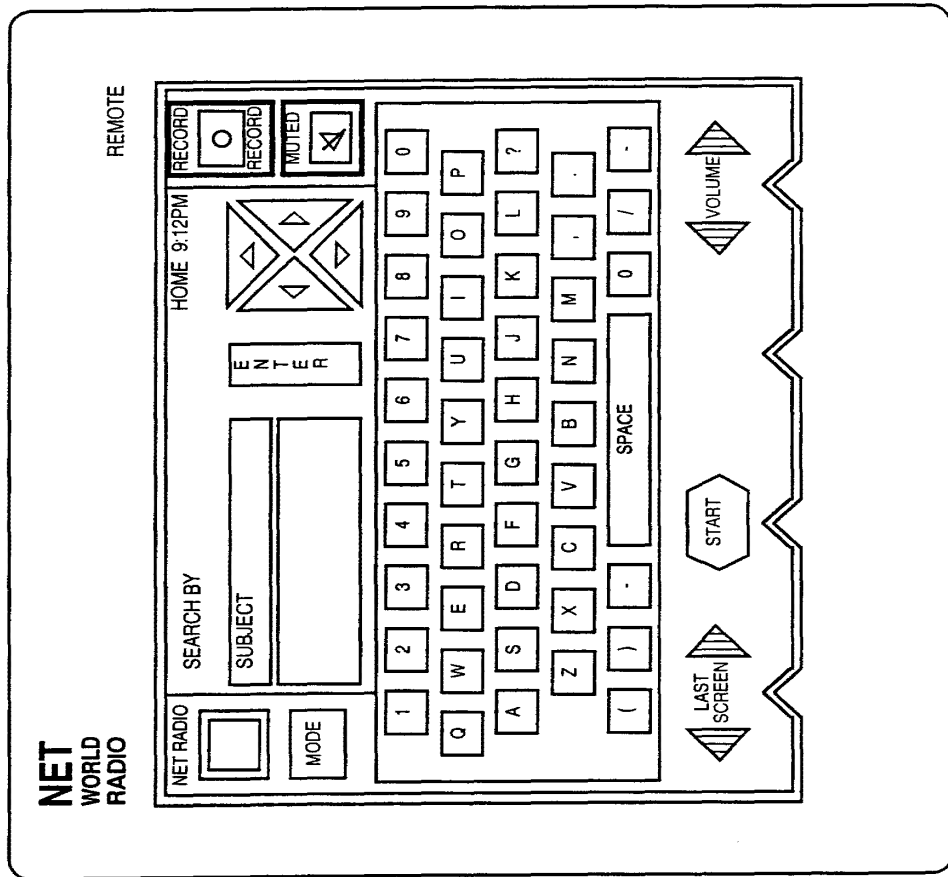


FIG. 12

→ 12A

→ 12A



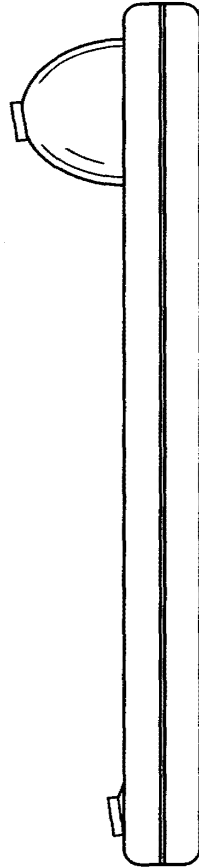
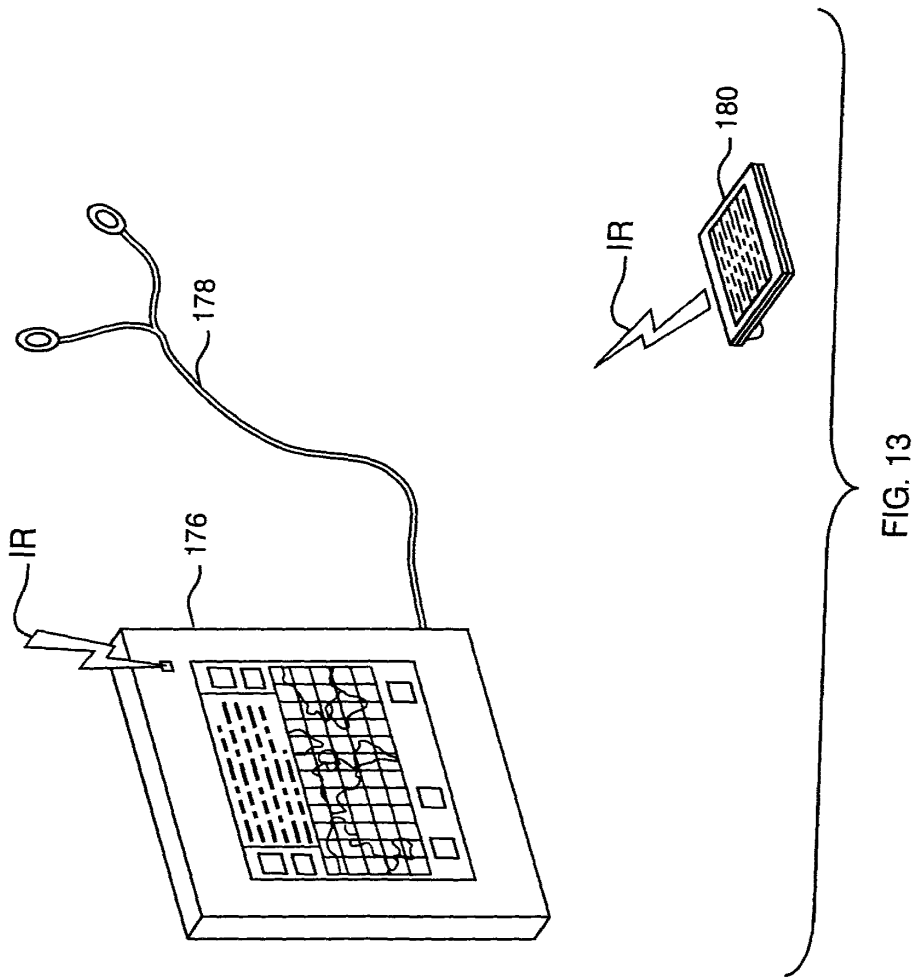
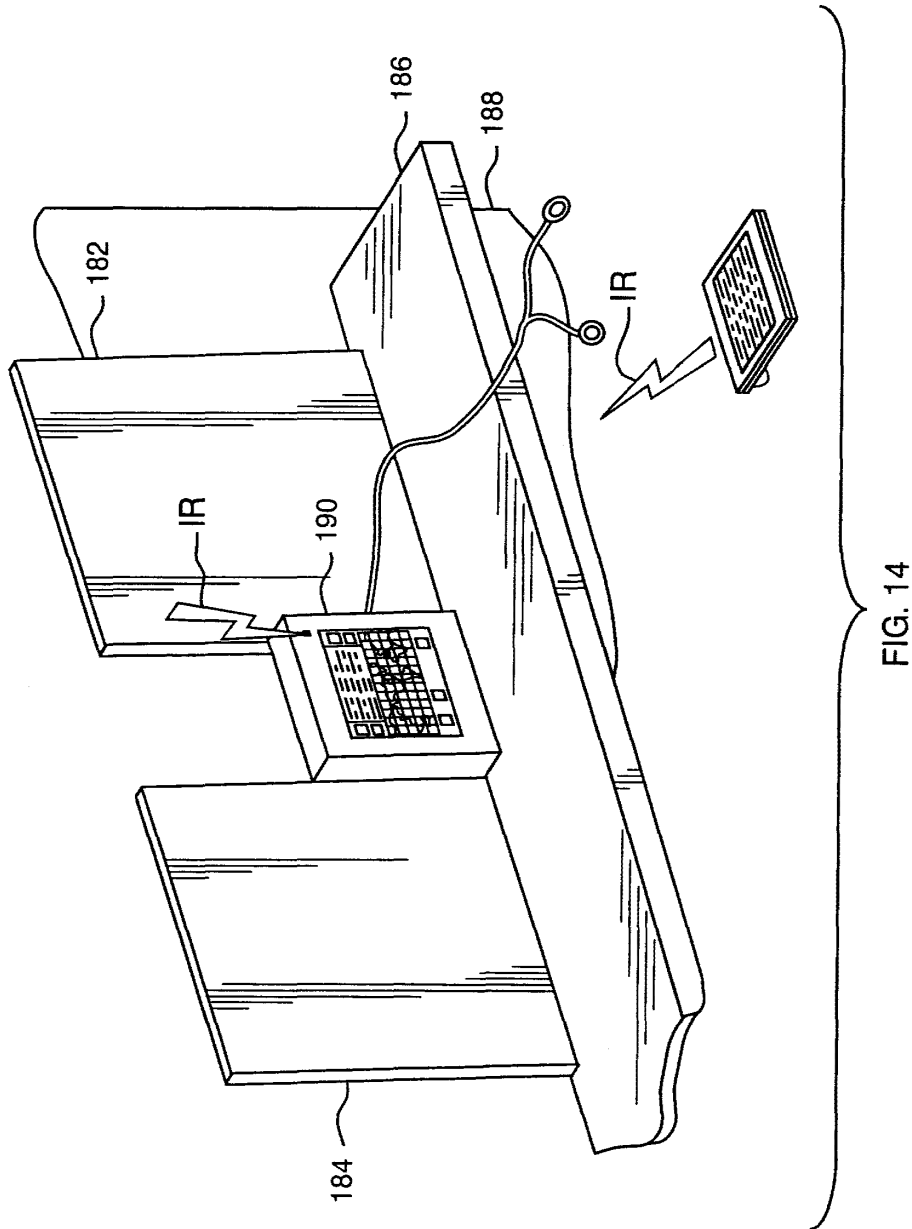
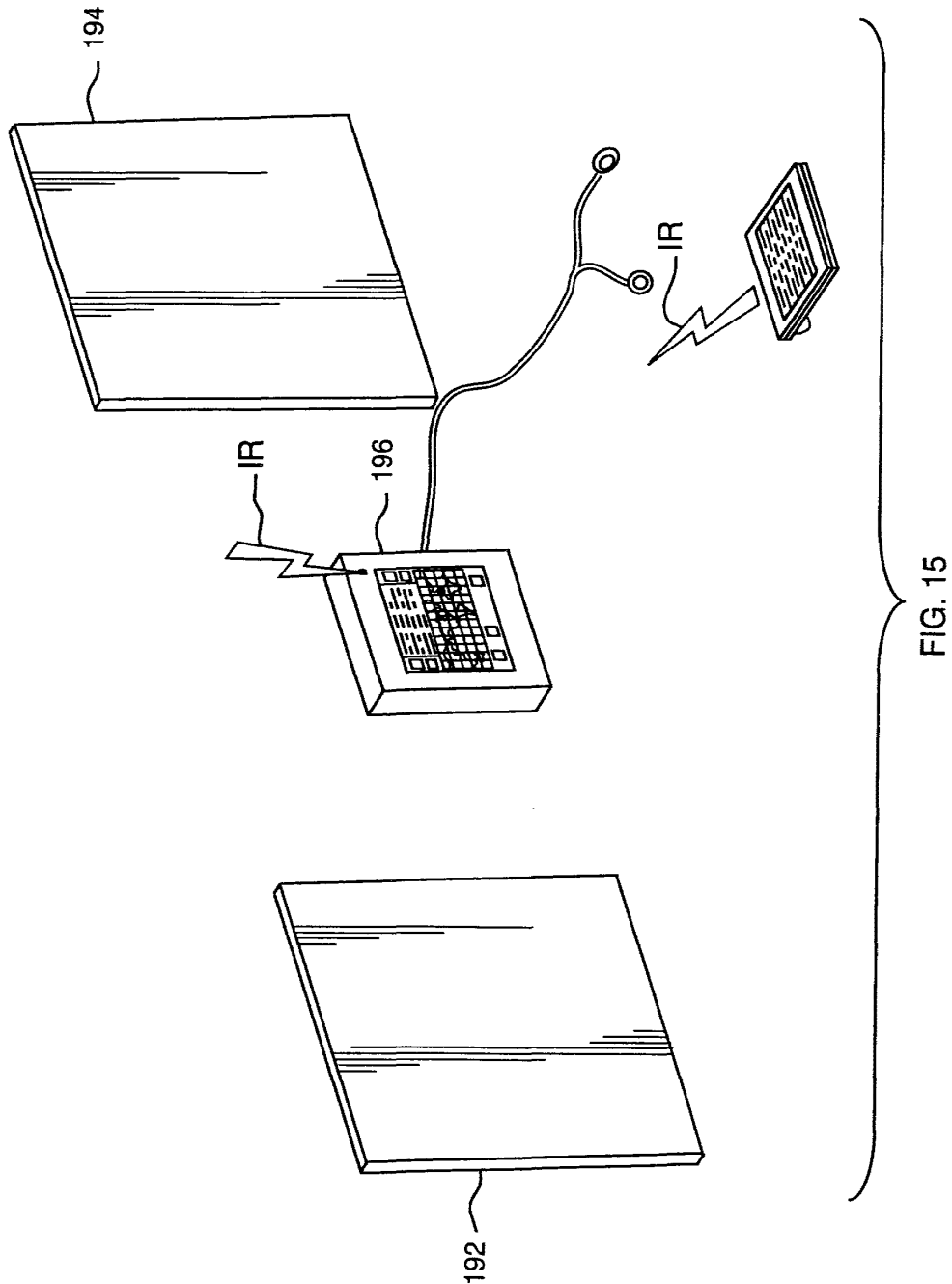
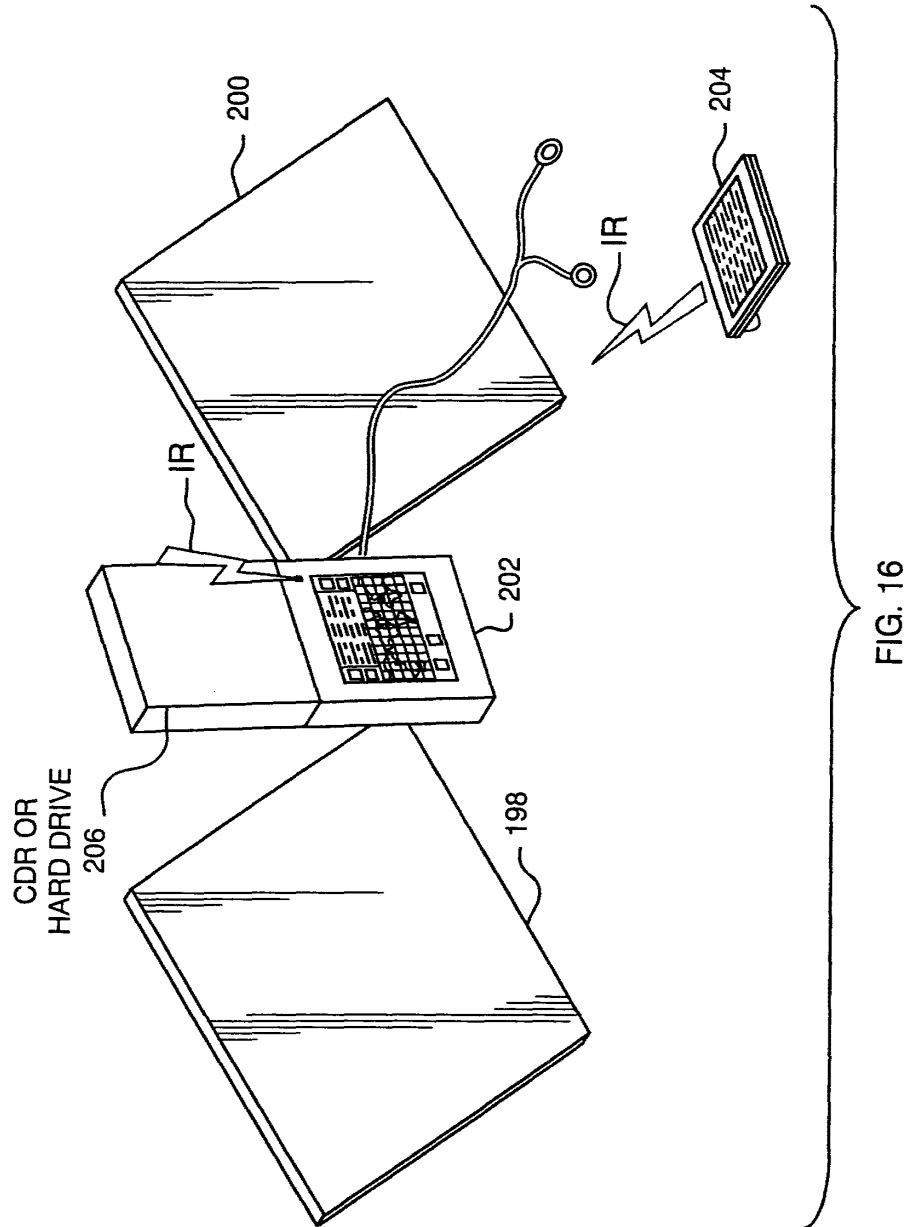


FIG. 12B









20/29

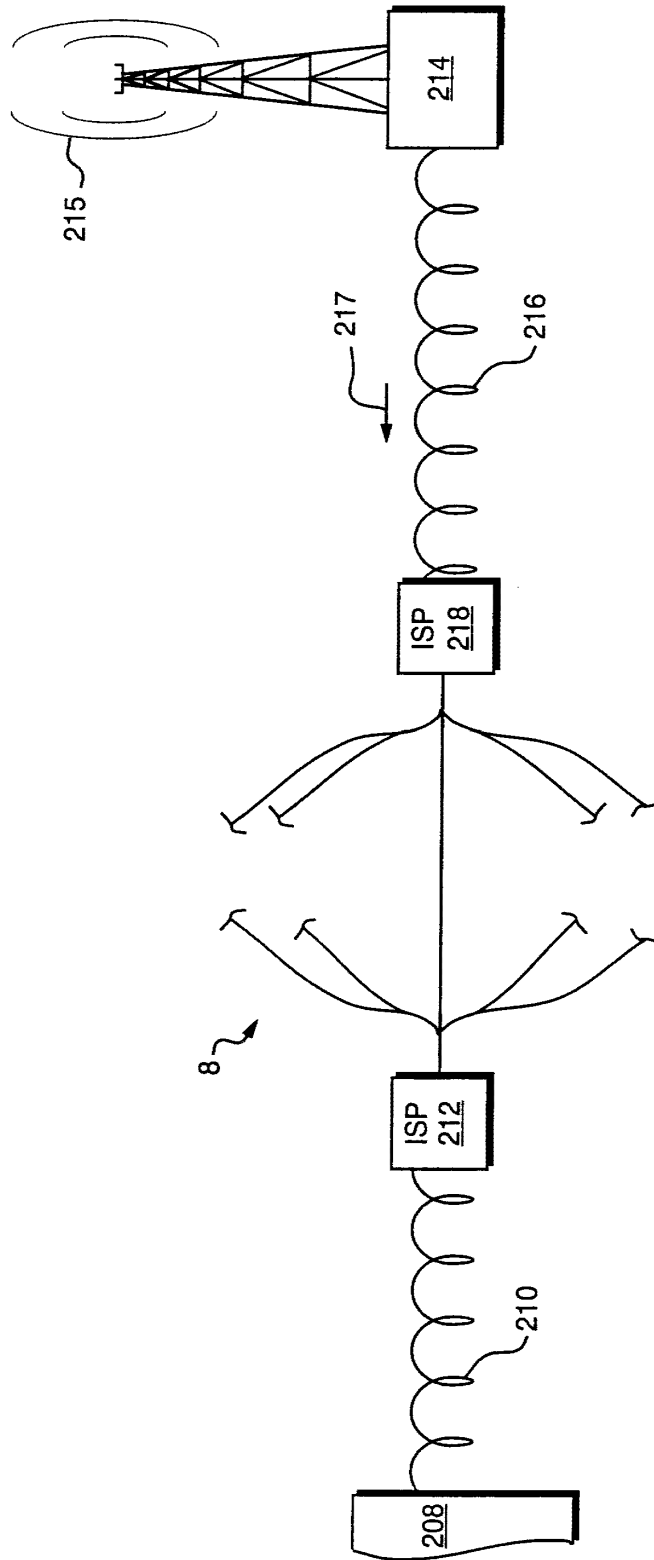


FIG. 17

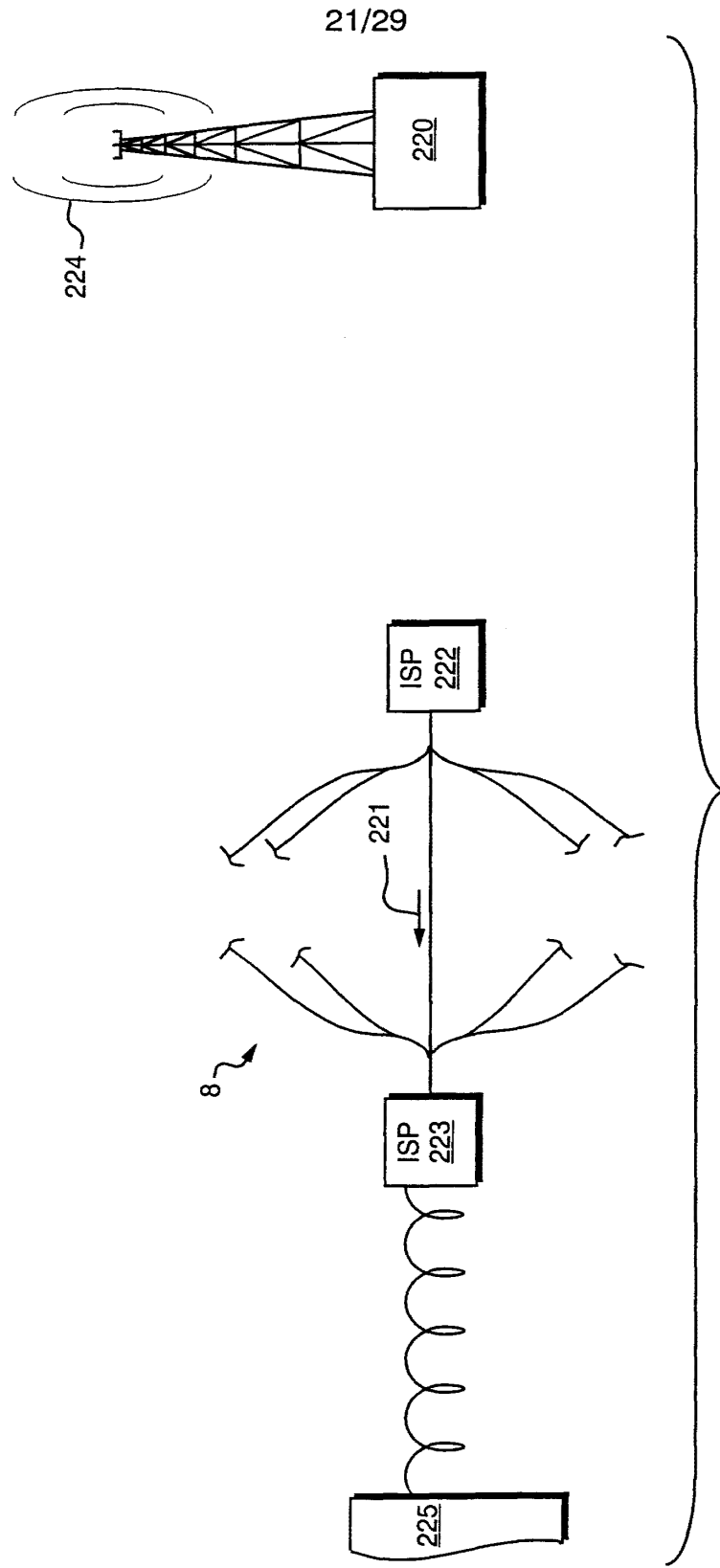


FIG. 18

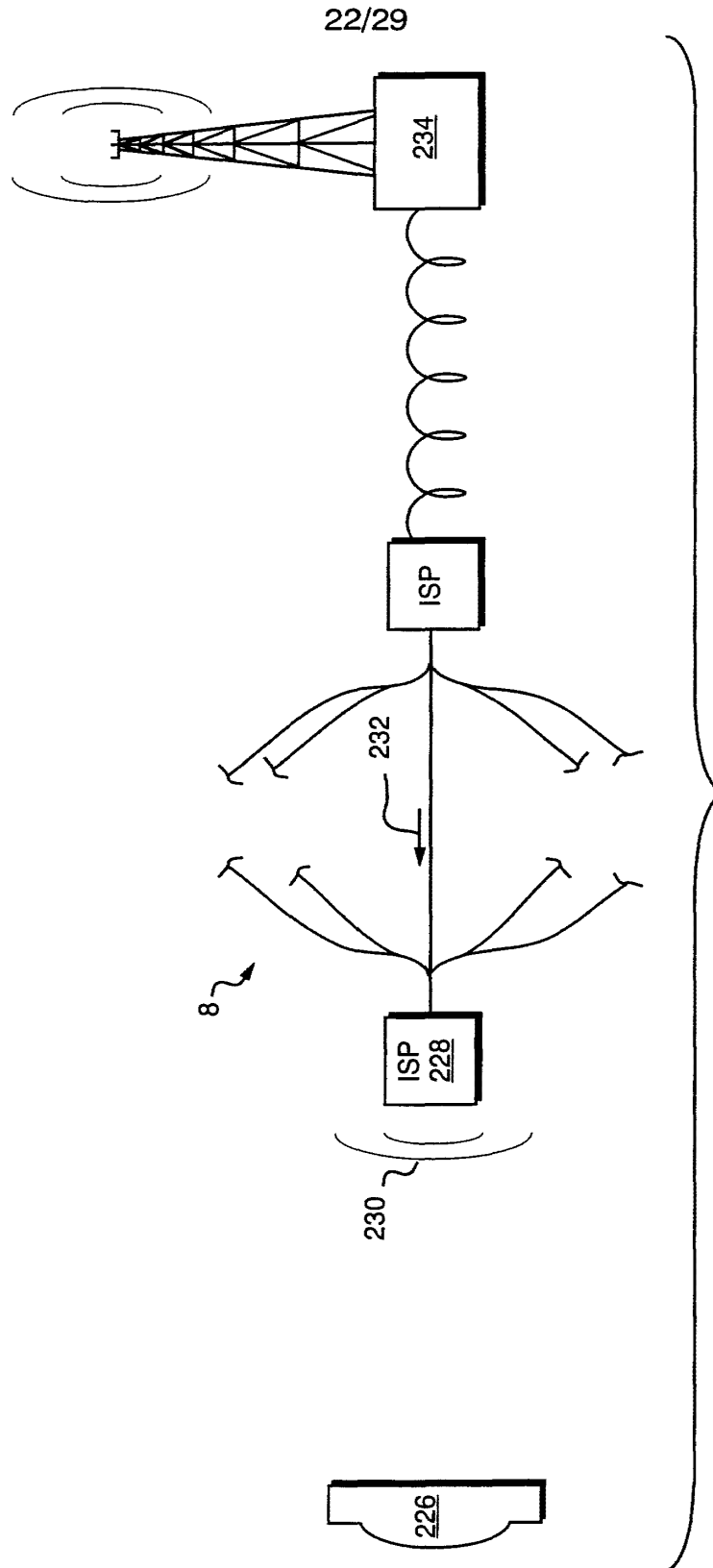
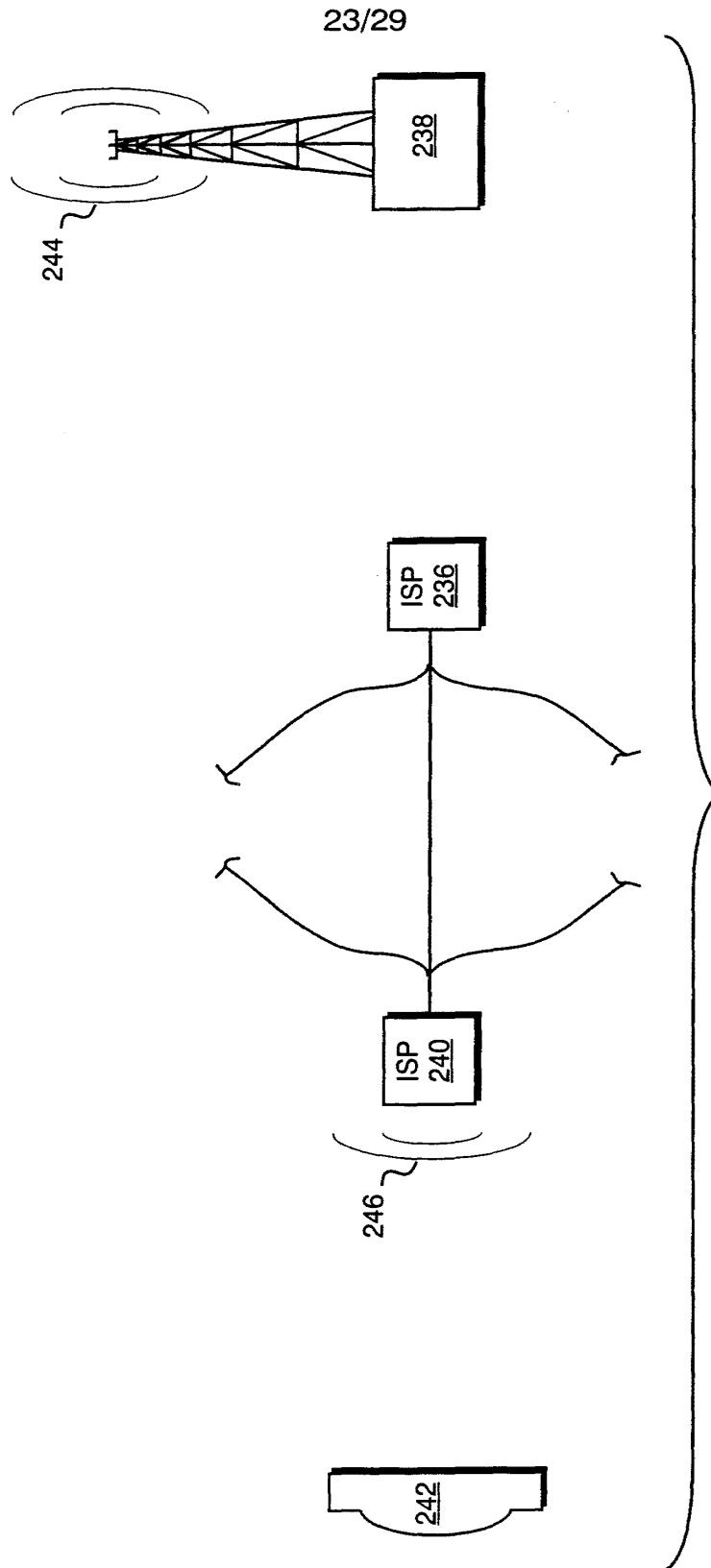


FIG. 19





24/29

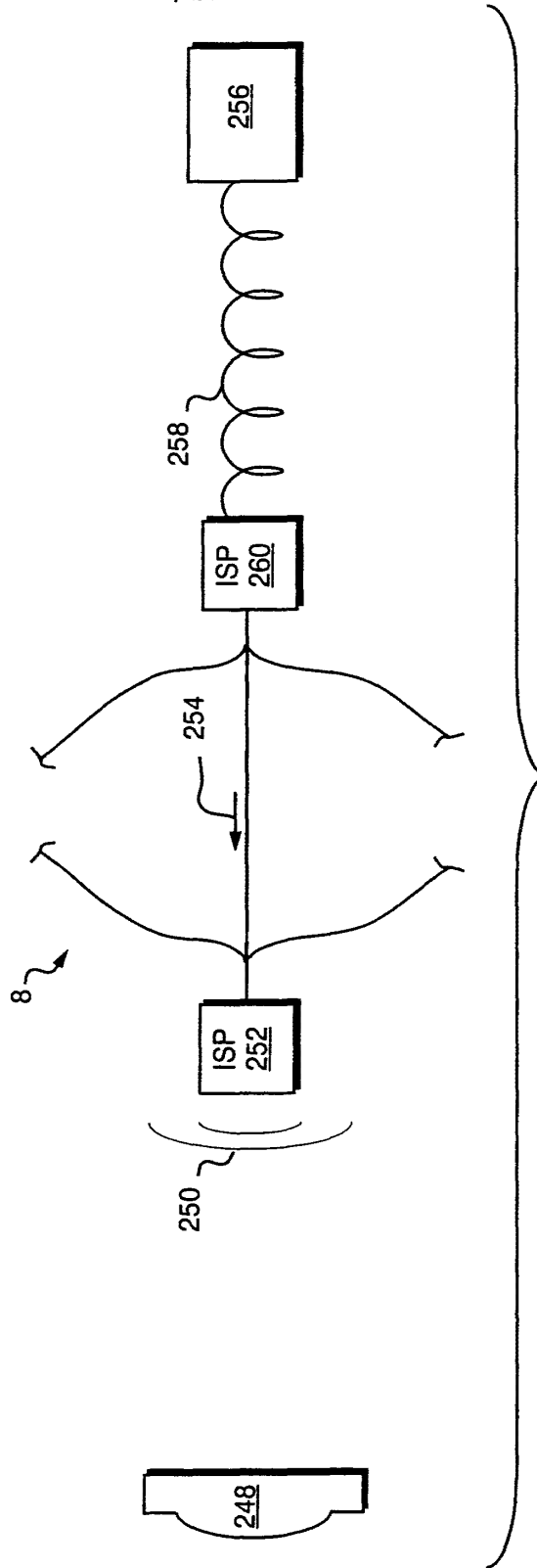


FIG. 21

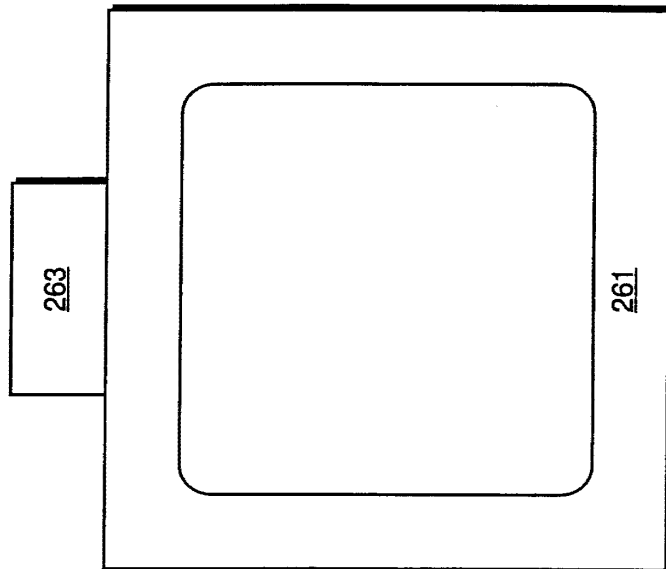
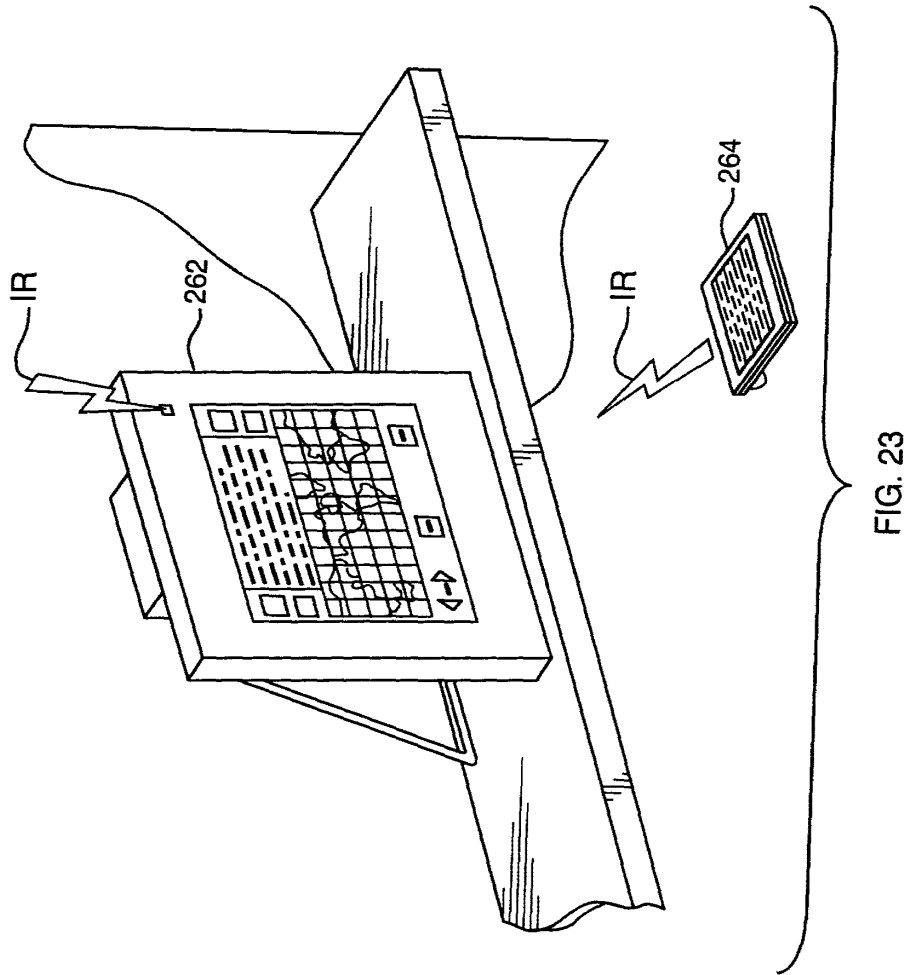
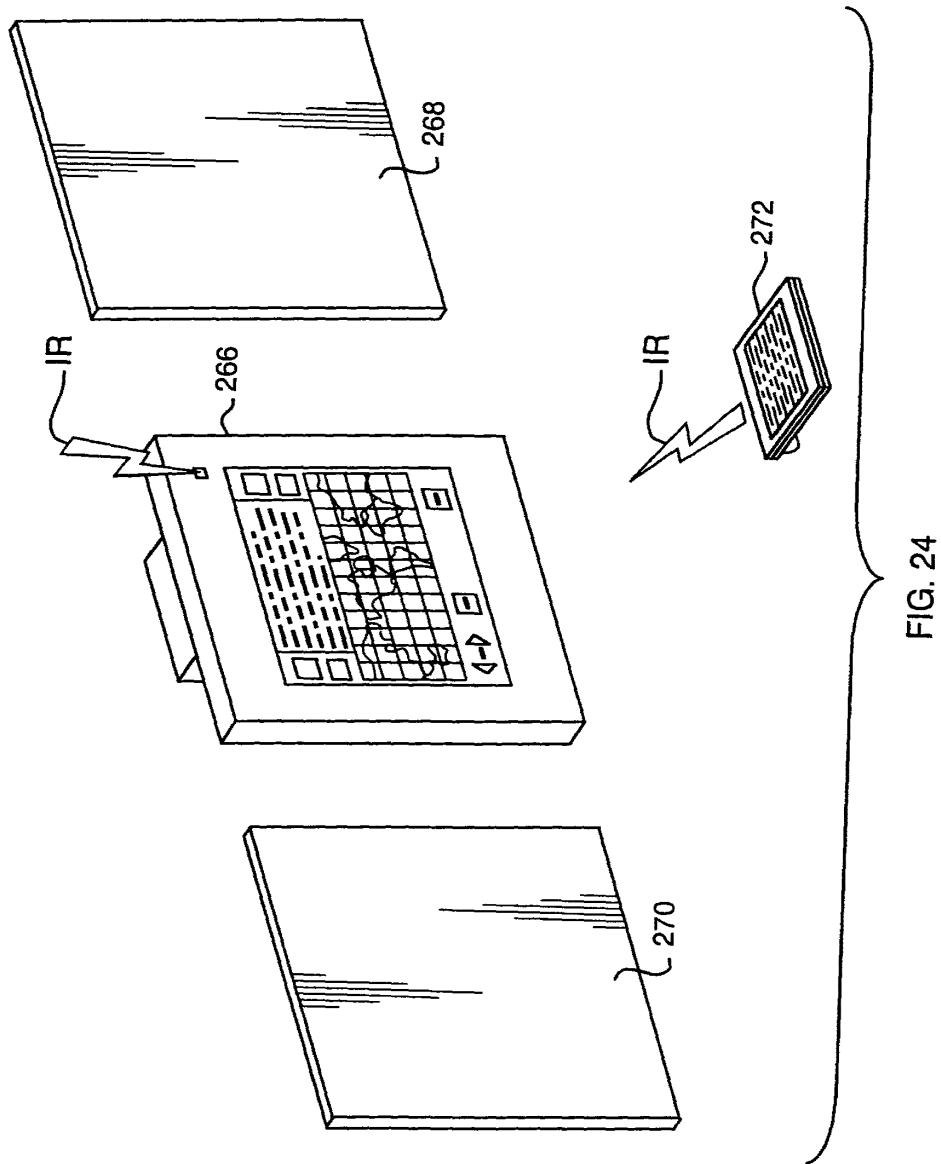


FIG. 22





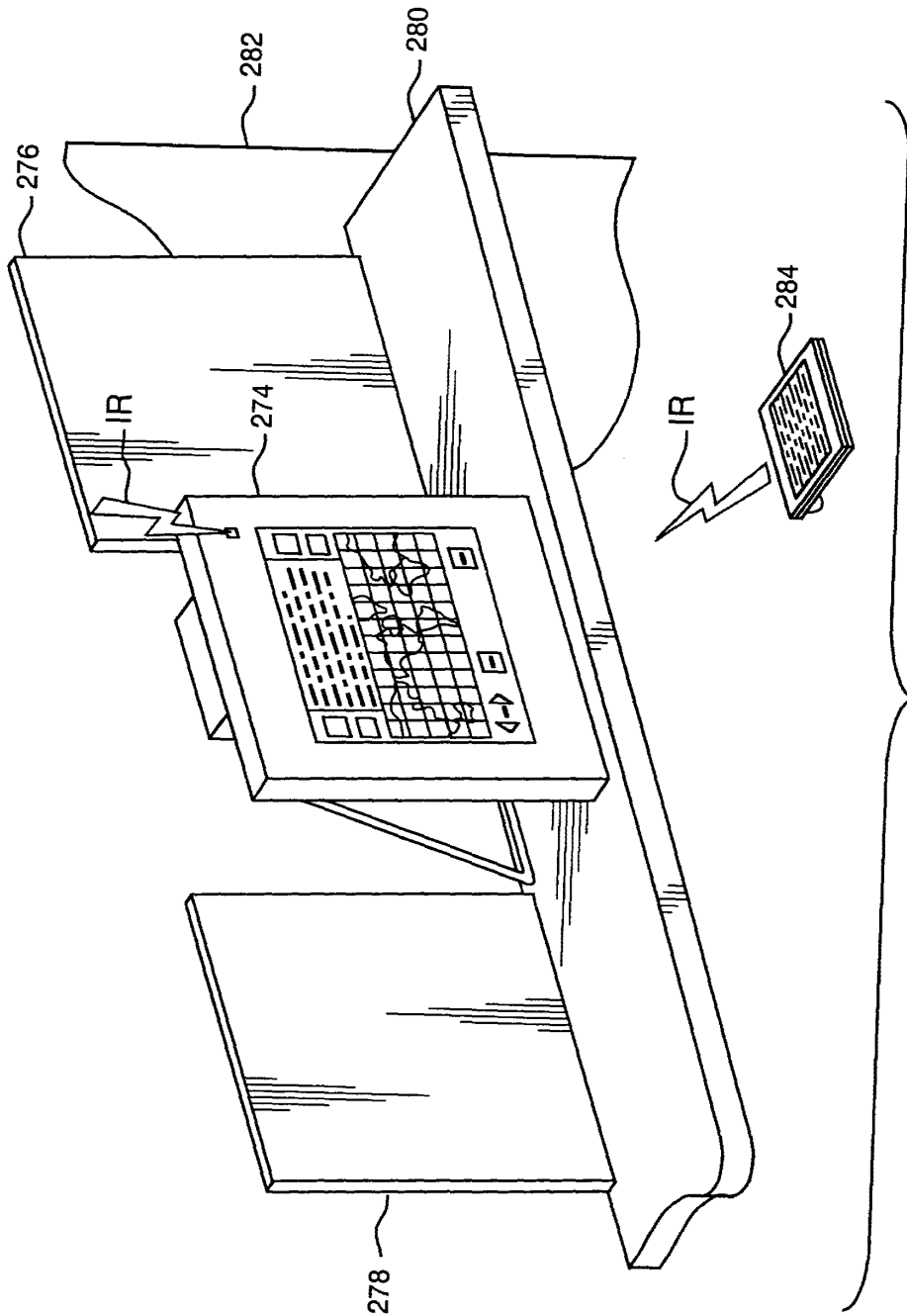
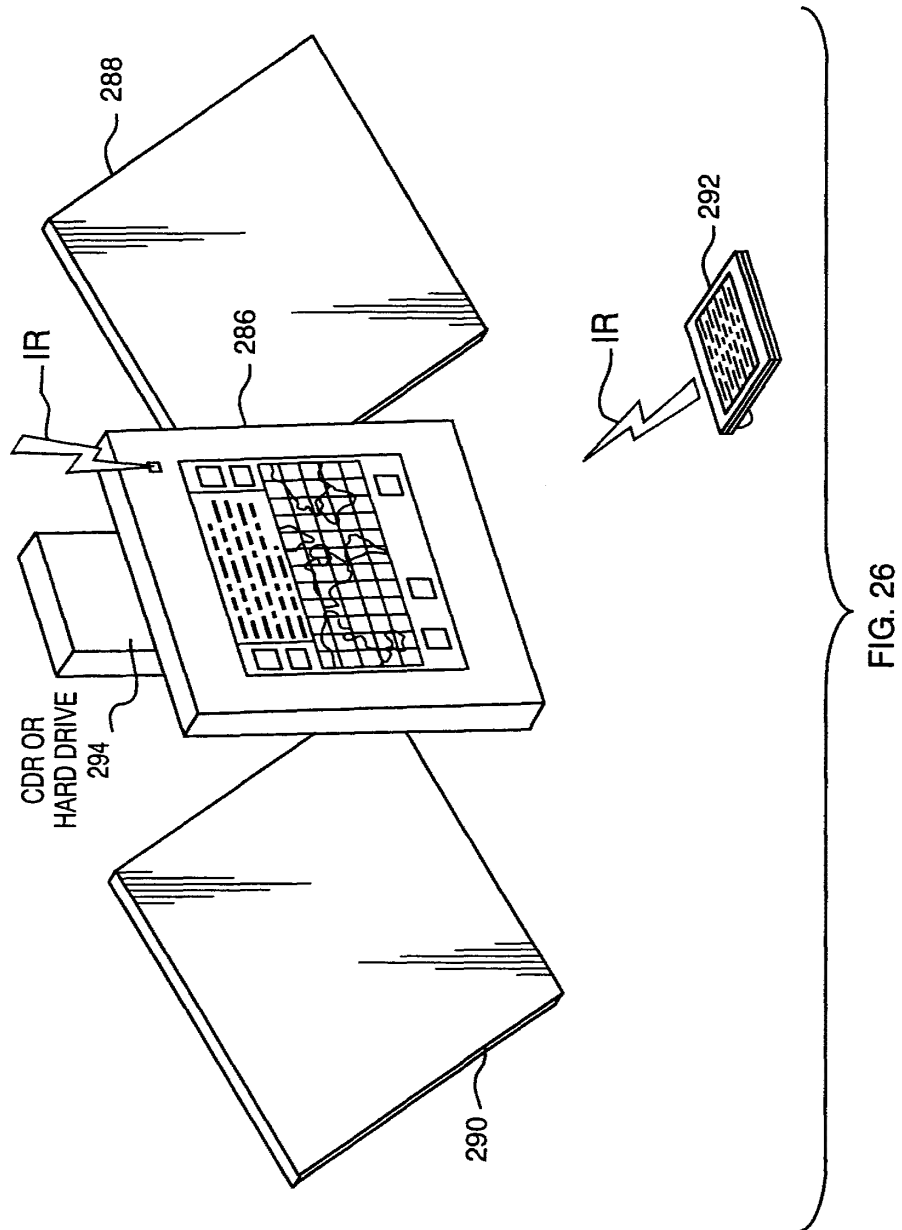


FIG. 25



(12) INTERNATIONAL APPLICATION PUBLISHED UNDER THE PATENT COOPERATION TREATY (PCT)

(19) World Intellectual Property Organization  
International Bureau



(43) International Publication Date  
18 January 2001 (18.01.2001)

PCT

(10) International Publication Number  
WO 01/05078 A3

(51) International Patent Classification<sup>7</sup>: H04J 3/16

(21) International Application Number: PCT/US00/18831

(22) International Filing Date: 10 July 2000 (10.07.2000)

(25) Filing Language: English

(26) Publication Language: English

(30) Priority Data:  
09/351,251 12 July 1999 (12.07.1999) US

(71) Applicant and

(72) Inventor: WEINGARTEN, Walter, Jay [US/US]; 2nd Floor, 2801-B Avenue P, Brooklyn, NY 11229 (US).

(74) Agents: COCH, Nicholas, L. et al.; Kramer, Levin, Naf-talis & Frankel LLP, 919 Third Avenue, New York, NY 10022 (US).

(81) Designated States (national): AE, AG, AL, AM, AT, AU, AZ, BA, BB, BG, BR, BY, BZ, CA, CH, CN, CR, CU, CZ,

DE, DK, DM, DZ, EE, ES, FI, GB, GD, GE, GH, GM, HR, HU, ID, IL, IN, IS, JP, KE, KG, KP, KR, KZ, LC, LK, LR, LS, LT, LU, LV, MA, MD, MG, MK, MN, MW, MX, MZ, NO, NZ, PL, PT, RO, RU, SD, SE, SG, SI, SK, SL, TJ, TM, TR, TT, TZ, UA, UG, UZ, VN, YU, ZA, ZW.

(84) Designated States (regional): ARIPO patent (GH, GM, KE, LS, MW, MZ, SD, SL, SZ, TZ, UG, ZW), Eurasian patent (AM, AZ, BY, KG, KZ, MD, RU, TJ, TM), European patent (AT, BE, CH, CY, DE, DK, ES, FI, FR, GB, GR, IE, IT, LU, MC, NL, PT, SE), OAPI patent (BF, BJ, CF, CG, CI, CM, GA, GN, GW, ML, MR, NE, SN, TD, TG).

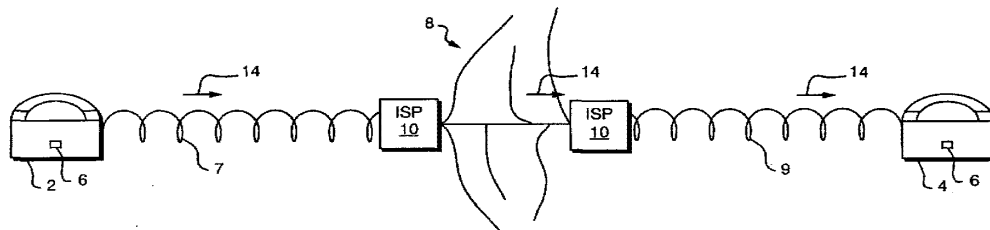
Published:

— With international search report.

(88) Date of publication of the international search report:  
31 May 2001

For two-letter codes and other abbreviations, refer to the "Guidance Notes on Codes and Abbreviations" appearing at the beginning of each regular issue of the PCT Gazette.

(54) Title: TRANSPARENT SYSTEMS FOR COMMUNICATION OVER COMPUTER NETWORKS



WO 01/05078 A3

(57) Abstract: Telephone (2), radio, and television systems for communication over computer networks conduct audio, video and other forms of communication over computer networks upon entry of appropriate input on devices included within the telephonic (2), radio, and television systems.



**INTERNATIONAL SEARCH REPORT**

International application No.  
PCT/US00/18831

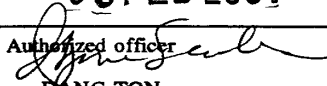
**A. CLASSIFICATION OF SUBJECT MATTER:**  
IPC (7):

H04J 3/16

H04J 3/16

INTERNATIONAL SEARCH REPORT

International application No.  
PCT/US00/18831

<b>A. CLASSIFICATION OF SUBJECT MATTER</b> IPC(7) :Please See Extra Sheet. US CL :370/465,466,351,352,389,552,490; 348/110,26,734; 358/142 According to International Patent Classification (IPC) or to both national classification and IPC		
<b>B. FIELDS SEARCHED</b> Minimum documentation searched (classification system followed by classification symbols) U.S. : 370/465,466,351,352,389,552,490; 348/110,26,734; 358/142 Documentation searched other than minimum documentation to the extent that such documents are included in the fields searched NONE Electronic data base consulted during the international search (name of data base and, where practicable, search terms used) NONE		
<b>C. DOCUMENTS CONSIDERED TO BE RELEVANT</b>		
Category*	Citation of document, with indication, where appropriate, of the relevant passages	Relevant to claim No.
X	US 5,774,357 A ( HOFFBERG ET AL.) 30 June 1998, see columns 23-25.	1-18
A,P	US 6,081,750 A (HOFFBERG ET AL.) see abstract. 27 June 2000	1
<input type="checkbox"/> Further documents are listed in the continuation of Box C. <input type="checkbox"/> See patent family annex.		
* Special categories of cited documents:	*T*	later document published after the international filing date or priority date and not in conflict with the application but cited to understand the principle or theory underlying the invention
*A* document defining the general state of the art which is not considered to be of particular relevance	*X*	document of particular relevance; the claimed invention cannot be considered novel or cannot be considered to involve an inventive step when the document is taken alone
*B* earlier document published on or after the international filing date	*Y*	document of particular relevance; the claimed invention cannot be considered to involve an inventive step when the document is combined with one or more other such documents, such combination being obvious to a person skilled in the art
*L* document which may throw doubts on priority claim(s) or which is cited to establish the publication date of another citation or other special reason (as specified)	*A*	document member of the same patent family
*O* document referring to an oral disclosure, use, exhibition or other means		
*P* document published prior to the international filing date but later than the priority date claimed		
Date of the actual completion of the international search 16 DECEMBER 2000	Date of mailing of the international search report 08 FEB 2001	
Name and mailing address of the ISA/US Commissioner of Patents and Trademarks Box PCT Washington, D.C. 20231 Facsimile No. (703) 305-3230	Authorized officer  DANG TON Telephone No. (703) 305-4739	

Form PCT/ISA/210 (second sheet) (July 1998)\*

(19) World Intellectual Property Organization  
International Bureau



(43) International Publication Date  
5 April 2001 (05.04.2001)

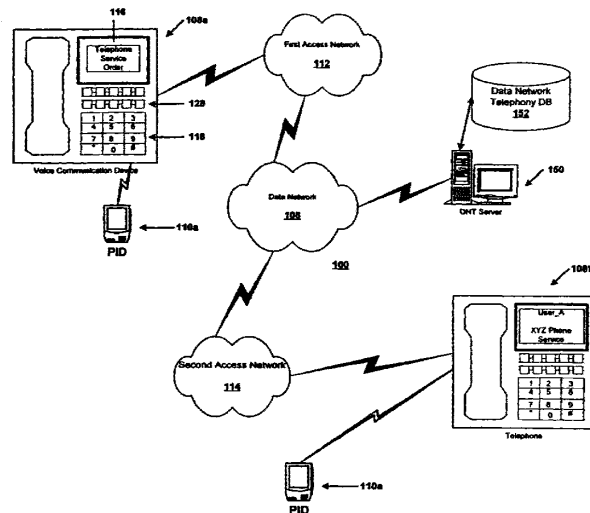
PCT

(10) International Publication Number  
WO 01/24496 A1

- (51) International Patent Classification<sup>7</sup>: H04M 3/42, Chicago, IL 60614 (US). BEZAITIS, Andrew; 2716 Troy Street, Chicago, IL 60647 (US).  
H04Q 3/00, H04M 7/00
- (21) International Application Number: PCT/US00/26094 (74) Agent: PEREZ, Enrique; McDonnell Boehnen Hulbert & Berghoff, 300 South Wacker Drive, Chicago, IL 60606 (US).
- (22) International Filing Date: 22 September 2000 (22.09.2000) (81) Designated States (national): CA, GB.
- (25) Filing Language: English (84) Designated States (regional): European patent (AT, BE, CH, CY, DE, DK, ES, FI, FR, GB, GR, IE, IT, LU, MC, NL, PT, SE).
- (26) Publication Language: English
- (30) Priority Data: 09/405,283 27 September 1999 (27.09.1999) US Published:  
— With international search report.  
— Before the expiration of the time limit for amending the claims and to be republished in the event of receipt of amendments.
- (71) Applicant: 3COM CORPORATION [US/US]; 3800 Golf Road, Rolling Meadows, IL 60008 (US).
- (72) Inventors: SIDHU, Ikhtaq, S.; 403 River Grove Lane, Vernon Hills, IL 60061 (US). SCHUSTER, Guido, M.; Apartment 408, 1433 Perry Street, Des Plaines, IL 60016 (US). DEAN, Frederick, D.; 2311 N. Greenview Avenue,

For two-letter codes and other abbreviations, refer to the "Guidance Notes on Codes and Abbreviations" appearing at the beginning of each regular issue of the PCT Gazette.

(54) Title: SYSTEM AND METHOD FOR PROVIDING USER-CONFIGURED TELEPHONE SERVICE IN A DATA NETWORK TELEPHONY SYSTEM



(57) Abstract: A system and method for providing user-configured telephone service to a user of a data network telephone. The user connects a data network telephone to the data network. The data network telephone registers with a telephone connection server to have basic calling service. The user accesses a service provider server to enter feature selections. The service provider server may use a web page to query the user for feature selections. The service provider server uses the user's selections to update the user's account and to activate the selected features.

WO 01/24496 A1

**SYSTEM AND METHOD FOR PROVIDING USER-CONFIGURED  
TELEPHONE SERVICE IN A DATA NETWORK TELEPHONY SYSTEM**

**BACKGROUND OF THE INVENTION**

5           **A. Field of the Invention**

The present invention is related to field of telecommunications, and more particularly to a system and method for providing communication services over a network.

10           **B. Description of the Related Art and Advantages of the Present  
Invention**

For many years, telephone service providers on the Public Switched Telephone Network (PSTN) provided their customers nothing more than a telephone line to use to communicate with other subscribers. Over time, telephone service providers have enhanced their service by providing Custom Local Area Signaling Service (CLASS) features to their customers. Similar communication services are provided by a Private  
15 Branch Exchange (PBX), which is typically implemented in a nonresidential setting.

The CLASS features permit customer subscribers of the features to tailor their telephone service according to individual needs. Some of the well known CLASS features are:

- 20           • Call blocking: The customer may specify one or more numbers from which he or she does not want to receive calls. A blocked caller will hear a rejection message, while the callee will not receive any indication of the call.
- Call return: Returns a call to the most recent caller. If the most recent caller is busy, the returned call may be queued until it can be completed.
- 25           • Call trace: Allows a customer to trigger a trace of the number of the most recent caller.
- Caller ID: The caller's number is automatically displayed during the silence period after the first ring. This feature requires the customer's line to be equipped with a device to read and display the out-of-band signal containing the number.
- 30           • Caller ID blocking: Allows a caller to block the display of their number in a callee's caller ID device.

- Priority ringing: Allows a customer to specify a list of numbers for which, when the customer is called by one of the numbers, the customer will hear a distinctive ring.

- Call forwarding: A customer may cause incoming calls to be automatically forwarded to another number for a period of time.

A customer subscriber to a CLASS feature may typically activate and/or deactivate a CLASS feature using "\*" directives (e.g., \*69 to automatically return a call to the most recent caller). CLASS features may also be implemented with the use of out-of-band data. CLASS feature data is typically transmitted between local Class-5 switches using the Signaling System 7 (SS7).

Local Exchange Carriers (LECs) and other similar organizations maintain CLASS offices that typically contain a database entry for each customer. The database allows specification of the CLASS features a customer has subscribed to, as well as information, such as lists of phone numbers, associated with those features. In some cases, customers may edit these lists on-line via a touch-tone interface. A list of all phone numbers that have originated or terminated a call with each customer is often included in the CLASS office database. For each customer, usually only the most recent number on this list is stored by the local Class-5 switch.

A Private Branch Exchange (PBX), is a stored program switch similar to a Class-5 switch. It is usually used within a medium-to-large-sized business for employee telephony service. Since a PBX is typically operated by a single private organization, there exists a wide variety of PBX services and features. Custom configurations are common, such as integration with intercom and voice mail systems. PBX's typically support their own versions of the CLASS features, as well as other features in addition to those of CLASS. Most PBX features are designed to facilitate business and group communications.

A summary of typical PBX features includes:

- Call transfer: An established call may be transferred from one number to another number on the same PBX.
- Call forwarding: In addition to CLASS call forwarding, a PBX number can be programmed to automatically transfer a call to another number when the first number does not answer or is busy.

- Camp-on queuing: Similar to PSTN call return, a call to a busy number can be queued until the callee can accept it. The caller can hang up their phone and the PBX will ring them when the callee answers.
- Conference calling: Two or more parties can be connected to one another by dialing into a conference bridge number.
- Call parking: An established call at one number can be put on hold and then reestablished from another number. This is useful when call transfer is not warranted.
- Executive override: A privileged individual can break into an established call. After a warning tone to the two participants, the call becomes a three-way call.

10           While the CLASS and PBX features have enhanced the offerings of service providers that use the PSTN, the features are nevertheless limited in their flexibility and scope. The effect to the user is that the features become clumsy and difficult to use. For example, in order to use the Call Forwarding function, the user must perform the steps at the user's own phone prior to moving to the location of the  
15           telephone to which calls will be forwarded. A more desirable approach, from the standpoint of usefulness to the user, would be to perform the steps at the telephone to which calls will be forwarded.

          Much of the lack of flexibility of the PSTN features is due to the lack of flexibility in the PSTN system itself. One problem with the PSTN is that the terminal  
20           devices (e.g. telephones) lack intelligence and operate as "dumb" terminals on a network having the intelligence in central offices. Most PSTN telephones are limited in functional capability to converting the analog signals they receive to sound and converting the sound from the handset to analog signals.

          Some PSTN telephones have a display device and a display function to display  
25           specific information communicated from intelligent agents in the PSTN network using the PSTN signaling architecture. For example, some PSTN telephones have a display function to enable the Caller ID feature. Even such PSTN telephones are limited however by the closed PSTN signaling architecture, which prohibits access by the PSTN telephones to the network signaling protocols. The display functions are  
30           effectively limited to displaying text, again, as a "dumb" terminal.

          The Internet presents a possible solution for distributing intelligence to telephony terminal devices. In Internet telephony, digitized voice is treated as data

and transmitted across a digital data network between a telephone calls' participants. One form of Internet telephony uses a telephony gateway/terminal where IP telephony calls are terminated on the network. PSTN telephones are connected by a subscriber line to the gateway/terminal at the local exchange, or at the nearest central office.

5 This form of Internet telephony provides substantial cost savings for users. Because the PSTN portion used in Internet telephony calls is limited to the local lines on each end of the call, long distance calls may be made for essentially the cost of a local call. Notwithstanding the costs savings provided by this form of Internet telephony, it is no more flexible than the PSTN with respect to providing enhancements and features to  
10 the basic telephone service.

In another form of Internet telephony, telephones are connected to access networks that access the Internet using a router. The telephones in this form of Internet telephony may be substantially more intelligent than typical PSTN telephones. For example, such a telephone may include substantially the computer  
15 resources of a typical personal computer.

It would be desirable to incorporate CLASS and PBX features into a data network telephony system that uses a data network such as the Internet.

It would be desirable to provide new features and enhancements to telephony service that accommodates and conforms to users' needs.

20 It would also be desirable to provide features and capabilities to telephone service that create new opportunities for users and for service providers.

The present invention addresses the above needs by providing a system in a data network telephony system, such as for example, the Internet, that provides a way for users to make brand new telephones usable without having to wait while the  
25 telephone company programs an account. The embodiments of the present invention may also be used to modify existing telephone accounts to incorporate new features, or features that may be desired for a limited amount of time.

One advantage of the present invention is that telephone features become user-configurable.

30 Another advantage is that the extent to which features are user-configurable may be determined by the service provider. The service provider may wish to make a

few basic features standard and impose their use in a registration function. Other features may then be made selectable by the user.



**BRIEF DESCRIPTION OF THE DRAWINGS**

Presently preferred embodiments of the invention are described below in conjunction with the appended drawing figures, wherein like reference numerals refer to like elements in the various figures, and wherein:

5           FIG. 1 is block diagram of a data network telephony system for providing telephony and enhanced telephony services in accordance with embodiments of the present invention;

          FIG. 2A shows one embodiment of the system of FIG. 1 showing examples of access to data network telephony service providers;

10           FIG. 2B shows one example of one of the data network telephones in FIG. 2A;

          FIG. 3A is a block diagram showing the interaction between components in accordance with one example of a system and method for configuring a data network telephone for service in the data network telephony system in FIG. 2A;

          FIG. 3B is a block diagram showing one example of the interaction between  
15 components in the embodiment shown in FIG. 4A to update the data network telephone version;

          FIG. 3C is a block diagram showing one example of the interaction between components in the embodiment shown in FIG. 4A when registration is complete;

          FIG. 4A is a block diagram showing one example of the interaction between  
20 components in the embodiment shown in FIG. 4A to provision the data network telephone version with a voice account;

          FIG. 4B is a depiction of a sample screen for ordering telephone service for the data network telephone of FIG. 5A;

          FIG. 4C is a block diagram showing the interaction between components in the  
25 embodiment shown in FIG. 4A to confirm service;

          FIG. 4D is a depiction of a sample screen for confirming telephone service for the data network telephone of FIG. 5A;

          FIG. 5 is a block diagram showing the interaction between components in accordance with an example of a system and method for communicating by data  
30 network telephone in the data network telephony system in FIG. 2A;

          FIG. 6 is a flowchart showing an example of a method for registering a data network telephone using the data network telephony system of FIG. 1;

FIG. 7 is a flowchart showing an example of a method for provisioning a data network telephone in the data network telephony system of FIG. 1; and

FIG. 8 is a flowchart showing an example of confirming the telephony service ordered using the method described in FIG. 7.

### DETAILED DESCRIPTION OF THE PREFERRED EMBODIMENT

The following references to patent applications filed concurrently herewith are incorporated by reference:

- 5 \* "System and Method for Controlling Telephone Service Using a Wireless Personal Information Device" to Schuster, et al.
  - \* "System and Method for Advertising Using Data Network Telephone Connections" to Schuster, et al.
  - \* "System and Method for Accessing a Network Server Using a Portable Information Device Through a Network Based Telecommunication System" to  
10 Schuster, et al.
  - \* "System and Method for Interconnecting Portable Information Devices Through a Network Based Telecommunication System" to Schuster, et al.
  - \* "System and Method for Enabling Encryption on a Telephony Network" to Schuster, et al.
  - 15 \* "System and Method for Using a Portable Information Device to Establish a Conference Call on a Telephony Network" to Schuster, et al.
  - \* "System and Method for Associating Notes with a Portable Information Device on a Network Telephony Call" to Schuster, et al.
  - \* "System and Method for Providing Shared Workspace Services Over a  
20 Telephony Network" to Schuster, et al.
  - \* "System and Method for Providing Service Provider Configurations for Telephones in a Data Network Telephony System" to Schuster, et al.
- The following additional references are also incorporated by reference herein:
- \* "Multiple ISP Support for Data Over Cable Networks" to Ali Akgun, et al.
  - 25 \* "Method and System for Provisioning Network Addresses in a Data-Over-Cable System" to Ali Akgun, et al., Serial No. 09/218,793.
  - \* "Network Access Methods, Including Direct Wireless to Internet Access" to Yingchun Xu, et al., Serial No. 08/887,313

#### 30 A. Data Network Telephony System

FIG. 1 is a block diagram showing an example of a system 100 for providing telephony services according to preferred embodiments of the present invention. The

system includes a data network 106. A first voice communication device 108a communicates by a voice connection over the data network 106 by establishing the connection via first access network 112. The voice connection may be linked to a second voice communication device 108b which is accessed via a second access  
5 network 114.

The data network 106 in the system 100 typically includes one or more Local Area Networks (LANs) connected to one another or to a Wide-Area Network (WAN), such as an Internet Protocol (IP) network, to provide wide-scale data connectivity. The data network 106 may use Voice Over Packet (VOP) schemes in which voice  
10 signals are carried in data packets. The network 106 may also include a connection to the Public Switched Telephone Network (PSTN) to allow for voice connections using traditional circuit switching techniques. In one embodiment, the data network 106 may include one or more LANs such as Ethernet LANs and support data transport protocols for performing Voice-over-Internet-Protocol (VoIP) techniques on the  
15 Internet. For further details regarding VoIP, see the information available through the Internet Engineering Task Force (IETF) at [www.ietf.org](http://www.ietf.org). In addition, an Internet Telephony gateway may be included within the system 100 to allow for voice connections to users connected by subscriber lines at a PSTN Central Office.

The first and second voice communication devices 108a and 108b typically  
20 include a voice input, a voice output and a voice processing system (described further below with reference to Figures 2B). The voice processing system converts voice sound from the voice input to digital data signals that are communicated on a voice connection over the data network. The voice processing system also converts digital data signals received from the voice connection to voice sound at the voice output.  
25 The voice communication devices 108a and 108b typically include a central processing unit and memory to store and process computer programs. Each voice communication device 108a and 108b typically includes a unique network address, such as an IP address, in memory to uniquely identify it to data network 106 and permit data packets to be routed to the device.

30 A first personal information device (PID) 110a may be connected to the first voice communication device 108a and may communicate over the data network 106 by connecting via the access network 112. The PID 110a may communicate with a

second PID 110b connected to the second voice communications device 108b.

Connections by the PIDs 110a,b may be made using the IrDA protocol or the Bluetooth system. Point to point links may include an RS232 port.

The PIDs 110a,b each contain user attributes stored in a user information  
5 database. The user attributes may contain such information as a user identifier,  
schedule information, and other information that is associated with a user of the PIDs  
110a,b. The PIDs 110a,b each include a user interface allowing a user to easily enter  
and retrieve data. In a preferred embodiment, the user interface includes a pressure-  
sensitive display that allows a user to enter input with a stylus or other device. An  
10 example of a PID with such an interface is a PDA (Personal Digital Assistant), such as  
one of the Palm™ series of PDAs offered by 3Com Corporation. The PIDs 110a,b  
may include other functionality, such as wireless phone or two way radio  
functionality.

In one embodiment, the voice communication device 108a includes a handset  
15 with a receiver and transmitter similar or identical to handsets of traditional circuit-  
switched telephones. A console on which the handset sits may include the voice  
processing system, a display 116 and a keypad 118. The voice communication device  
108a may also include a speed dial key set 128 programmed, or assigned to initiate  
connections to other voice communication devices that may be connected to the data  
20 network 106. In a preferred embodiment, the keys on the speed dial key set 128 may  
be programmed remotely by a message carried on a voice connection using a selected  
data transport protocol.

One example of the voice communication device 108a in a preferred  
embodiment is the NBX 100™ communication system phones offered by 3Com®  
25 Corporation, that has been modified, as described herein, to perform speed dial  
programming. In alternative embodiments, the voice communication device 108a  
may include any device having voice communications capabilities. For example, a  
personal computer having a microphone input and speaker output may also be used as  
the voice communication device 108a. Other configurations for the user interface are  
30 also intended to be within the scope of the present invention.

The details relating to operation of the voice communication devices 108a and  
108b depend on the nature of the data network 106 and the nature of the access

networks 112, 114 connecting the voice communication devices 108a and 108b to each other and/or to other network entities. The access networks 112, 114 typically include any high bandwidth network adapted for data communications, i.e. a network having greater than 64,000 bits-per-second (bps) bandwidth. The access networks  
5 112, 114 may link to the voice communication device 108a using an Ethernet LAN, a token ring LAN, a coaxial cable links (e.g. CATV adapted for digital communication), a digital subscriber line (DSL), twisted pair cable, fiberoptic cable, an integrated services digital network (ISDN) link, and wireless links. In embodiments that may not require a bandwidth greater than 64,000 bps, the access networks 112, 114 may  
10 also include the PSTN and link the voice communications device 108a by an analog modem. Further details regarding specific implementations are described below, with reference to FIGs. 2A and 2B.

#### **B. System For Providing Provisioning and Configuration Services for a Telephone Using A Data Network Telephony System**

15 One advantage of the data network telephony system 100 in FIG. 1 is that a user may begin making telephone calls by connecting the data network telephone to the access network. Alternatively, another advantage of the system 100 is that the user may plug the data network telephone to the access network to receive rudimental service, but obtain access to fully personalized, user-configured service account as  
20 well as to user-selected telephony enhancements and features.

A service provider server 120, connected to the data network 106, maintains user service accounts and manages the transport of data communications channels between voice communications devices 108a, 108b. A service provider database 122 stores the user accounts and other subscription information. In accordance with  
25 preferred embodiments, the service provider server 120 provides voice communications devices 108a, 108b with rudimentary service sufficient to connect to a service provider. The service provider server 120 then sets up user interactive connections to allow a user to configure a telephony user account. The user account is then activated substantially contemporaneously with the user interactive connection  
30 once the user submits the information. By substantially contemporaneously, it is meant that no substantial waiting period is needed before the user account may be used. In alternative embodiments, the service provider server 120 configures voice

communications devices 108a, 108b with a full, ready-to-use configuration. The service provider host 120 also makes modifications to the user accounts easy and immediate in effect. A user may select features for temporary use. For example, a user may set up call forwarding to use while at a meeting for a week, and then disable it for other times.

1. Local Area Network As  
An Exemplary Access  
Network

FIG. 2A is a block diagram showing one example of the system 100 of FIG. 1 for providing customized communication services according to the present invention. The system 200 in FIG. 2A includes a local area network 212, connected to a data network 206 by a first router 228 and a cable network 214 connected to the data network 206 by a second router 238. Those of ordinary skill in the art will appreciate that, while the local area network 212 and the cable network 214 are shown in FIG. 2A as access networks, any other type of network may be used. For example, the local area network 212 and/or the cable network 214 may be replaced by ISDN, DSL, or any other high-speed data link.

The local area network 212 provides data connectivity to its members, such as a first data network telephone 208a, a second data network telephone 208b, a gateway 222 and a network telephony connection server 150a. The local area network 212 in FIG. 2A is an Ethernet LAN operating according to the IEEE 802.3 specification, which is incorporated by reference herein, however, any other type of local area network may be used. The local area network 212 uses the router 228 to provide the data network telephone 208a,b, the gateway 222 and the network telephony connection server 150a with access to the data network 206. For example, the router 228 may perform routing functions using protocol stacks that include the Internet Protocol and other protocols for communicating on the Internet.

The network telephony connection server 150a (hereinafter “telephony connection server”) provides telephony registration, location and call initiation services for voice connections in which its members are a party. A user may register for telephony service with an administrator of the telephony connection server 150a and receive a user identifier and a telephone identifier. The user identifier and telephone identifier may be sequences of unique alphanumeric elements that callers

use to direct voice connections to the user. The telephony connection server 150a registers users by storing user records in a data network telephony user database (hereinafter “user database”) 152a in response to registration requests made by the user.

5           The call setup process and the user and telephone identifiers preferably conform to requirements defined in a call management protocol. The call management is used to permit a caller anywhere on the data network to connect to the user identified by the user identifier in a data network telephone call. A data network telephone call includes a call setup process and a voice exchange process. The call  
10       setup process includes steps and message exchanges that a caller and callee perform to establish the telephone call. The actual exchange of voice signals is performed by a data communications channel. The data communications channel incorporates other data transport and data formatting protocols, and preferably includes well-known data communications channels typically established over the Internet.

15           The call management protocol used in FIG. 2A is the Session Initiation Protocol (SIP), which is described in M. Handley et al., “SIP: Session Initiation Protocol,” IETF RFC 2543, Mar. 1999, incorporated by reference herein, however, any other such protocol may be used. Other protocols include H.323, the Media Gateway Control Protocol (MGCP), etc.

20           The local area network 206 is connected to a gateway 222. The gateway 322 communicates with a PSTN central office 224, which provides PSTN service to a PSTN phone 226. The PSTN phone 226 is likely to be one of many PSTN phones serviced by the central office 224. Additional portions of a PSTN network have been omitted from FIG. 2A to improve clarity. The PSTN network is well known by those  
25       having skill in the art of telecommunications.

          The telephony connection server 150a provides telephony service for mobile users. A user may be registered to use the first network telephone 208a (which is identified by its telephone identifier), but move to a location near the second data network telephone 208b. The user may re-register as the user of the second data  
30       network telephone 208b. Calls that identify the user by the user’s user identifier may reach the user at the second network telephone 208b.



## 2. The Data Network Telephones

The data network telephones 208a, b are Ethernet phones which are telephones that include an Ethernet communications interface for connection to an Ethernet port.  
5 The Ethernet phones in FIG. 2A support the Internet Protocol (IP), using an IP address that is either statically configured or obtained by access to a Dynamic Host Configuration Protocol (DHCP) server.

FIG. 2B is a block diagram showing the data network telephone 208a connected to the local area network 212 in FIG. 2A. The data network telephone 208  
10 in FIG. 2B is connected to the network 212 by a network interface 210. The network interface 210 may, for example, be a network interface card, and may be in the form of an integrated circuit. A bus 248 may be used to connect the network interface 210 with a processor 240 and a memory 242. Also connected to the processor are user interface circuitry 261 and three alternative (and all optional) interfaces to the  
15 Personal Information Device (PID) 110 (shown in FIG. 1).

A first interface 248 includes an RS-232 serial connection and associated coupling hardware and mechanisms. The first alternative interface 248 may, for example, be a docking cradle for a PDA, in which information can be transferred between the PDA and the data network telephone 208. The second alternative  
20 interface comprises a first connection 254, such as an RS-232 connection, along with infrared circuitry 250 for converting signals into infrared output and for accepting infrared input. An infrared interface 252 may also be included within the second alternative interface. The third alternative interface comprises a first connection 256, such as an RS-232 connection, along with radio-frequency circuitry 258 for  
25 converting signals into radio frequency output and for accepting radio frequency input. A radio frequency interface 259 may also be included as part of the third alternative interface.

The three alternative interfaces described above are merely examples, and additional means for implementing the interface between the data network telephone  
30 208 and the PID may also be used. Although three interfaces are shown in FIG. 2B, there may be only one such interface in the data network telephone 208. More than one interface may be included to improve flexibility and to provide redundancy in case of failure of an interface.

The user interface circuitry 261 includes hardware and software components that access the functions of the handset, display, keypad and speed dial keypad to provide user input and output resources for functions in the processor 240. The user interface circuitry includes a display interface 262, a keypad interface 264, a speed dial interface 266, an audio output interface 265 and an audio input interface 267.

The audio input interface 267 may receive voice signals from a microphone or other audio input device and converts the signals to digital information. The conversion preferably conforms to the G.711 ITU Standard. Further processing of the digital signal may be performed in the audio input interface 267, such as to provide compression (e.g. using G.723.1 standard) or to provide noise reduction, although such processing may also be performed in the processor 240. Alternatively, the audio input interface 267 may communicate an analog voice signal to the processor 240 for conversion to digital information.

The audio output interface 265 receives digital information representing voice from the processor 240 and converts the information to sound. In one embodiment, the speaker interface receives information in the form of G.711 although other processing such as decompression may be performed in the speaker interface 265. Alternatively, the processor 240 may convert digital information to analog voice signals and communicate the analog voice signals to the speaker interface 265.

The speed dial interface 266, the keypad interface 264 and the display interface 262 include well-known device interfaces and respective signal processing techniques. The speed dial interface 266 may include an interface to buttons on a keypad, or to display buttons that the user activates by pressing designated areas on the screen.

The user interface circuitry 261 may support other hardware and software interfaces. For example, a videophone implementation might also include a camera and monitor. The fixed communication device of the present invention is not limited to telephones or videophones – additional user interface types, for example, such as the ones needed for computer games, are also contemplated as being within the scope of the present invention.

The processor 240 may consist of one or more smaller processing units, including, for example, a programmable digital signal processing engine. In the preferred embodiment, the processor is implemented as a single ASIC (Application

Specific Integrated Circuit) to improve speed and to economize space. The processor 240 also includes operating system, application and communications software to perform the functions of the data network telephone 208. The operating system may be any suitable commercially available embedded or disk-based operating system, or  
5 any proprietary operating system.

The processor 240 includes a media engine 241 and a signaling stack 243 to perform the primary communications and applications functions of the data network telephone 208. The purpose of the signaling stack in an exemplary data network telephone 208 is to set up, manage, and tear down a call. During the setup phase, a  
10 user may use the keypad to enter a user identifier to call. The signaling stack 243 receives the user entry and formats a request message to send to the user identified by the user identifier to initiate a telephone call. The request message is sent to discover the location of the user identified by the user identifier, exchange communication parameters, such as the supported voice CODEC types, and establish the voice  
15 channel.

During the management phase, communication proceeds over the voice over data channel. Other parties may be invited to the call if needed or the existing CODEC can be changed. During the teardown phase, the call is terminated.

The signaling protocol used in the data network telephone 208 in FIG. 2B is  
20 the SIP protocol. In particular, the signaling stack implements a User Agent Client 244 and a User Agent Server 242, in accordance with the SIP protocol. Alternative signaling protocols, such as the ITU-T H.323 protocol and others, may also be used to implement the present invention.

Once the call is setup, the media engine 241 manages the communication over  
25 a data communications channel using a network transport protocol and the network interface 210. The media engine 241 sends and receives data packets having a data payload for carrying data and an indication of the type of data is being transported. The media engine 241 in the data network telephones 208 may sample the voice signals from the audio input 267 (or receive voice samples from the audio input 267),  
30 encode the samples, and build data packets on the sending side. On the receiver side, in addition to performing the reverse operations, the media engine also typically manages a receiver buffer to compensate for network jitter.

The media engine 241 includes hardware and software components for performing speed dial functions 246, registration functions 147, voice-over-data functions 249, display data function 251 and keypad output functions 253. The media engine 241 processes data that is received from the network 212, and data that is to be sent over the network 241.

For data that is received from the network 212, the media engine 241 may determine from the type of data in the packet whether packets contain sampled voice signals or data for performing other functions. Packets containing sampled voice signals are processed by voice over data function 249. The voice over data function 249 preferably conforms to a protocol for formatting voice signals as digital data streams. While any suitable protocol may be used, the media (voice signal) is preferably transported via the Real Time Protocol (RTP), which itself is carried inside of User Datagram Protocol (UDP). RTP is described in H. Schulzrinne et al., "RTP: A Transport Protocol for Real-Time Applications," IETF RFC 1889, Jan. 1996, which is incorporated herein by reference. UDP is described in J. Postel, "User Datagram Protocol," IETF RFC 768, Aug. 1980, and IP is described in J. Postel, ed., "Internet Protocol," IETF RFC 791, Sept. 1981, both of which are incorporated by reference herein.

Packets containing data for use in registering the data network telephone 208 with a network telephony service are processed by the registration/provisioning function 247. By registering the data network telephone 208, a user may establish with the network telephony service provider that calls addressed to the user's user identifier may be connected to the data network telephone 208. Provisioning configures the data network telephone 208 with features and other user account information that relate to the service provider.

Registration may occur when the data network telephone 208 sends a request to register to a service provider host, which may occur during power up, if the data network telephone 208 is connected to the network 212, or when the user connects the data network telephone 208 to the network 212. The registration/provisioning function 247 may automatically send the Register request when the network is sensed. The service provider host may respond by setting the user's user identifier to correspond to the telephone identifier of the data network telephone 208, and by

acknowledging the request with a status message to the data network telephone 208. In one embodiment, the service provider host communicates a response message to the data network telephone that includes a service provider logo and/or a configuration program that programs selected features into the telephone. The selected features may include a speed dial assignment to a customer server, a help menu, a user-friendly display, etc.

Other features may be added to the registration/provisioning functions 247, or implemented as extensions to the registration functions 247. For example, the data network telephone 208 may be provisioned to provide selected network telephony features by establishing a data connection with a service provider, requesting the selected services, and receiving data that ensures that the services have been successfully provisioned. Such features may include, for example, caller identification, call forwarding, voice mail, unified voice/email, gateway services, PID-based applications, call conferencing, advertisement enable/disable, and any other service offered by the network telephony service provider to enhance the capabilities of the data network telephone 208. The requests for features may be made contemporaneously with setting up a new account (as described below with reference to FIGs. 3A-8). The features may also be requested to modify the service. Users need not be locked into any service plan or feature set. One advantage of such provisioning functions is that services may be ordered for temporary use in a manner that is convenient to the user.

Packets containing data that is to be displayed on the display device are processed by the display data function 251. The display data function 251 may be used for displaying, for example, the name(s) and user identifier(s) of the other party(-ies) to the call, the status of the telephone call, billing information, and other information. The display data function 251 may also provide access to the display interface 262 for the display of commercial messages sent from the commercial message server 120 (shown in FIG. 2A). The display data function 251 may process image data and text data that may be contained in and of the messages.

Packets containing data that programs or assigns speed dial keys are processed by the speed dial function 246. A speed dial key may be programmed during registration with the user identifier of the service provider's customer service

department, or to a provisioning service. When a message, or one or more packets, is received, the data in the commercial message is examined for speed dial programming data. The speed dial programming data may include a speed dial key selector to identify the speed dial key being programmed, and a user identifier used to initiate a telephone call when the selected speed dial key is pressed. The speed dial programming data may also include directions to be displayed on the display screen that inform the user that a selected speed dial key has been programmed. In addition, the speed dial programming data may include an icon for display on a touch sensitive screen that describes the user or service to be reached when the icon on the display is touched.

The speed dial programming data may also include an indication of whether the speed dial key is to be programmed permanently, or temporarily. Temporarily programmed keys may be programmed for the duration of the present call only, or for a selected time period. Permanently programmed speed dial keys are programmed until re-programmed later.

For data that is to be sent over the data network 212, the media engine 241 formats the data as data packets in accordance with a selected protocol. The selected protocol is preferably the protocol that is supported by the data network telephone that will receive the data for the particular type of data being transported.

The voice over data function 249 formats voice samples according to the protocol used by the receiving data network telephone. In one preferred embodiment, the voice over data function 249 formats voice samples as RTP packets. The registration function 247 and the keypad output function 253 may use RTP or other protocols to transport data that does not represent voice signals.

### 3. Cable Network As An Exemplary Access Network

Referring back to FIG. 2A, the system 200 includes a cable network 214 connected to the data network 206 by a router 238. The cable network 214 provides data network access to its members, which in FIG. 2A include a third data network telephone 218a, a fourth data network telephone 218b, a fifth data network telephone 218c, a workstation 218d, a second data network connection telephony server 150b and a network telephony connection database 152b. The users of the data network

telephones 218a-c connected to the cable network 214 may communicate by telephone over the data network 206 with the users of the data network telephones 208a,b connected to the local area network 214.

The cable network 214 includes any digital cable television system that provides data connectivity. In the cable network 214, data is communicated by radio frequency in a high-frequency coaxial cable. The cable network 214 may include a head-end, or a central termination system that permits management of the cable connections to the users.

The cable network 214 includes high-frequency coaxial cable connections for terminating the members, such as the data network telephones 218a-c and the workstation 218d. The third, fourth and fifth data network telephones 218a-c are preferably similar to the data network telephone 208 described with reference to FIG. 2B. One difference is that the third, fourth and fifth data network telephones 218a-c access telephone service over the cable network 214, and the first and second data network telephones 208a,b access telephone service over the Ethernet.

### **C. Providing Telephone Services By A Data Network Telephony Service Provider**

#### **1. Telephony Service Provider**

FIG. 2A shows a service provider host 160 having a service provider server 120 and a service provider database 122. The service provider server 120 registers data network telephones and performs user interactive connections with users to configure users' telephone accounts. The host 160 is connected to the data network 206, however, the host 160 may also be connected to either access network 212, 214. The host 160 may also include network telephony connection servers, such as server 150a,b. The host 160 may also communicate with separately located local network telephony connection servers 150, 152 for billing purposes, or for carrying out the features selected by users. The host 160 may be managed by a telephony service provider or by any entity for a telephony service provider.

The telephony connection server 150b is preferably a SIP-based server that performs call initiation, maintenance and teardown for the data network telephones 218a-c connected to the cable network 214. The telephony connection server 150b

may be similar or identical to the telephony connection server 150a connected to the local area network 212. The ISP host 160 includes the service provider server 120 and the service provider database 122.

5 The system 200 shown in FIG. 2A includes a data network telephony system that permits the data network telephones 208a, b connected to the local area network 212 to communicate with the data network telephones 214 connected to the cable network 214. The system shown in FIG. 2A uses SIP in order to establish, maintain and teardown sessions, or telephone calls between users.

10 There are two major architectural elements to SIP: the user agent (UA) and the network server. The UA resides at the SIP end stations, (e.g. the data network telephones), and contains two parts: a user agent client (UAC), which is responsible for issuing SIP requests, and a user agent server (UAS), which responds to such requests. There are three different network server types: a redirect server, a proxy server, and a registrar. The various network server types may be combined into a  
15 single server, such as the telephony connection server 150a,b. Not all server types are required to implement the embodiments of the present invention. The communication services to be provided will determine which servers are present in the communication system. Preferred embodiments of the present invention may be carried out using proxy servers.

20 One example of a SIP operation involves a SIP UAC issuing a request, a SIP proxy server acting as end-user location discovery agent, and a SIP UAS accepting the call. A successful SIP invitation consists of two requests: INVITE followed by ACK. The INVITE message contains a user identifier to identify the callee, a caller user identifier to identify the caller, and a session description that informs the called party  
25 what type of media the caller can accept and where it wishes the media data to be sent. User identifiers in SIP requests are known as SIP addresses. SIP addresses are referred to as SIP Uniform Resource Locators (SIP-URLs), which are of the form sip:user@host.domain. Other addressing conventions may also be used.

30 Redirect servers process an INVITE message by sending back the SIP-URL where the callee is reachable. Proxy servers perform application layer routing of the SIP requests and responses. A proxy server can either be stateful or stateless. A stateful proxy holds information about the call during the entire time the call is up,



while a stateless proxy processes a message without saving information contained in the message. Furthermore, proxies can either be forking or non-forking. A forking proxy can, for example, ring several phones at once until somebody takes the call. Registrar servers are used to record the SIP address (called a SIP URL) and the associated IP address. The most common use of a registrar server is for the UAC to notify the registrar where the UAC can be reached for a specified amount of time. When an INVITE request arrives for the SIP URL used in a REGISTER message, the proxy or redirect server forwards the request correctly.

At the local area network 212, the central registrar/proxy server, such as the network telephony server 150a is the primary destination of all SIP messages trying to establish a connection with users on the local area network 212. Preferably, the network telephony server 150a is also the only destination advertised to the SIP clients outside the LAN 212 on behalf of all the SIP clients residing on the LAN 212. The network telephony server 150a relays all SIP INVITE messages to the appropriate final destination (or another SIP proxy), based on a database lookup using the user database 152a. It allows all mobile clients to register with their current locations.

Similarly, the network telephony server 150b is the primary destination of all SIP messages trying to establish a connection with the data network telephones 218a-c connected to the cable network 214. Preferably, the network telephony server 150b is also the only destination advertised to the SIP clients outside the LAN 212 on behalf of all the SIP clients (e.g. data network telephones) residing on the LAN 212. The network telephony server 150b relays all SIP INVITE messages to the appropriate final destination (or another SIP proxy), based on a database lookup using the user database 152b.

## 2. Registration of the Telephone

The data network telephones 208a,b and 218a-c in the system 200 preferably have pre-programmed device identifiers (e.g. MAC addresses or phone numbers), represented as SIP-URL's that are of the form sip:8475551212@3com.com. After power-up, each data network telephones 208a,b and 218a-c sends a SIP REGISTER message to the default registrar, such as the network telephony servers 150a,b. When a call arrives at one of the network telephony servers 150a,b for any of the registered SIP URLs, the server will forward the call to the appropriate destination. If a data

network telephone is moved to a new location, all calls to the associated SIP URL will still be properly routed to that device. In other words, the system in FIG. 2A provides device mobility in the sense that calls will "follow" the data network telephone according to its SIP URL. This is especially useful if the data network telephone  
5 208a,b or 218a-c is running the DHCP (Dynamic Host Configuration Protocol) so that when the location is changed, the IP address is also automatically changed.

An advantage of the system in FIG. 2A is that the network telephony connection server 150a,b may respond to REGISTER messages (for SIP and similar messages in other protocols) with a message that configures the data network  
10 telephone 208a,b or 218a-c to have a variety of ready-to-use features. The service provider may configure the telephony connection server 150a,b to enforce a particular configuration for operation, or offer the user choices of features that comprise the configuration. A data network telephone may be configured to include features such as:

- User identifier: a sequence of alphanumeric elements that uniquely identifies the user. The user identifier may be formatted as an E.164 telephone number, or as a name. The user identifier may be unique throughout the universe of users on the data network telephony system 200 (shown in FIG. 1), or it may acquire such uniqueness by association with a server identifier.
- Telephone Identifier: a sequence of alphanumeric elements that uniquely identifies the telephone. The telephone identifier may be formatted as an E.164 telephone number, or as a number, such as a MAC address. The telephone identifier may be unique throughout the universe of data network telephones on the data network telephony system 200, or it may acquire such uniqueness by association with a server identifier.
- The user's name, address and other information that may be used primarily for billing purposes. For example, the user's checking account number, credit card number or other financial information may be provided for automatic billing and payment capabilities.
- User's telephony service features. The user may subscribe, permanently or temporarily, to one or more telephony service features offered by the service provider:
  - ◆ Voice mail
  - ◆ Caller ID
  - ◆ Call Forwarding with true number portability
  - ◆ Teleconferencing
  - ◆ Commercial messaging – a service that may be made available

in embodiments of the present invention. A user may subscribe to have the data network telephone 218 receive (or not to receive) advertisements for display on the display of the data network telephone 218.

- Commercial messaging with speed dial programming – a service that may be made available in embodiments of the present invention. A user may subscribe to have the data network telephone 218 receive (or not to receive) advertisements that program the speed dial keys of the data network telephone 218. The display of the service provider logo
- Menu of functions
- Help menu
- Speed dial key programming (*e.g.* speed dial to customer service)
- Features as standard offerings – to compete, a provider may offer features that normally cost extra (*e.g.* caller ID, etc.) as standard features
- Packaged configurations – Features and offerings may be grouped as distinctly priced packages
- Functions using PDA connectivity (*e.g.* Remote Whiteboard communication, control of telephone use through PDA)

TABLE A

FIG. 3A shows the data network telephone 208 for User A begin the registration process. User A's telephone 208 may be brand new, in which case, the process described with reference to FIGs. 3A-3D illustrates the ease with which the data network telephone 208 may be installed and used immediately. When User A connects the data network telephone 208 to the network 206 (NOTE: connection may be through an access network), the data network 208 uses its MAC address as an initial telephone identifier. The data network telephone 208 retrieves an IP address using a DHCP Discover message exchange, shown at 271, with a DHCP server 161.

The data network telephone 208 then sends a registration message as shown at 273. In a preferred embodiment, the registration message includes a temporary user identifier (xxxxxxxxxxxxxx) and a version identifier that identifies the current version of the configuration of the telephone 208. FIG. 3B shows a sample registration request at 472 in a message flow diagram.

Referring back to FIG. 3A, the telephony connection server 150a may respond to the registration message at 273 with a response message as shown at 275. The message at 275 includes an auto-configuration command which forces the data

network telephone 208 to implement a new configuration. The new configuration may be an update to the current version identified by the current version identifier. FIG. 3B shows a sample of the auto-configuration response at 474. In a preferred embodiment, the auto-configuration message is communicated in the message body of a SIP response message.

The response message at 275 in FIG. 3A may also comprise an exchange of messages using a data channel. FIG. 3B shows a first data channel message 480 having a query to the user in TCP transmitted as TCP/IP. It is to be understood that any other protocol may be used. The message may be formatted for display on the data network telephone 208, as voice over data in a voice mail session, or any other manner conforming to the user interface capabilities of the telephone 208. The user may respond by saying "Yes"/"No", selecting a menu item by touching the screen, pressing a yes/no button, or any other manner conforming to the user interface capabilities of the telephone 208.

The user's response is communicated in a second data channel 482 to the network telephony connection server 150a. If the response was a "Yes" such that the user wants the configuration of the data network telephone 208 updated, the network telephony connection server 150a responds with the updated version at 484.

Referring to FIG. 3C, the data network telephone 208 is shown as having been registered. The data network telephone 208 is shown configured with a phone number (user identifier), a service provider logo (xyz) and a hotlink, or display button programmed to dial customer service at 116 for the service provider. The service provider host 160 may configure the data network telephone with a full set of features, such as from those listed above, to allow the user to make full use of the data network telephone 208.

In an alternative embodiment, the registration process leaves the data network telephone 208 with a rudimentary configuration barely able to make any telephone calls. For example, the process may leave the data network telephone 208 capable of making only one call, to customer service for a user controlled provisioning of the system. The user may also provision the telephone 208 using a connection to the service provider's web page.

As shown in FIG. 4A, the user at data network telephone 208 makes a call at 281 to the service provider server 120 with its user identifier (xxxxxxxxxxxxxx), and a command to request service provisioning. A provisioning function, in response to the telephone call at 281, establishes a data connection 283 to perform the transfer  
5 (which may be with voice over data signals) of information. The service provider server 120 may send a form, or present an order screen 316, at the telephone requesting information from the user. The user may also use a workstation and connect at 287 to a web page 451 at the service provider server 120 and enter the information at a web page order screen 317. The information requested in both the  
10 order screen 316 and the web page order screen 317 is illustrated in FIG. 4B. One of ordinary skill in the art will appreciate that the web page order screen 317 is illustrated as an example of the type of information requested during a provisioning session. More or less information may be requested.

Referring to FIG. 4C, when the user has entered the data requested in the order  
15 screen, the service provider server 120 leaves a ready display 416 at the data network telephone 208 indicative of the type of configuration provided by the provisioning process. The service provider server 120 may also leave a confirmatory message 417 on the workstation (or on the data network telephone, either on the display or by voice) indicating what happens next. FIG. 4D shows an example of such a  
20 confirmatory message. Once the user responds to the email, the data network telephone 208 is ready for use.

The service provider server 120 also builds and stores in the service provider database 122 a user account 455 for the user as shown in FIG. 4A.

### 3. A Telephone Call

25 FIG. 5 shows the interaction between the components in FIG. 2A in performing a telephone call. As shown in FIG. 5, a telephony service provider (e.g. ISP) provides telephone service using the host 160. The telephony service provider may also provide data connectivity services and other services relating to communication (e.g. advertising) on the data network 206. With User A and User B  
30 registered with network telephony connection servers 150a,b respectively, the telephony connection server 150b operates as a proxy server (e.g. as a SIP proxy server) for User B's data network telephone 218. When other users, such as User A,

attempt to call User B, the call setup will be made through the telephony connection server 150b.

As shown in FIG. 5, User A initiates a telephone call from User A's data network telephone 208 to the data network telephone 218 belonging to User B. User A begins the telephone call by dialing User B's user identifier using the keypad 118 (or a PID, or a speed dial key, or using any other manner). The data network telephone 208 sends a request to initiate a call to User B at 280 to the data network telephony connection 150b providing service to User B. The request to initiate a call to User B at 280 includes User B's user identifier as the callee, User A's user identifier as the caller and the protocols supported by User A's data network telephone 208.

The telephony connection server 150b sends the request to the data network telephone 218 identified in the user database 152b as belonging to User B, preferably, in accordance with its role as a proxy server, and preferably as defined in the SIP protocol. The data network telephone 218 responds with a response message (not shown in FIG. 5) to the telephony connection server 150b. The telephony connection server 150b receives the response message and sends the response message to User A's data network telephone 208 as shown at 282.

User A's data network telephone 208 receives the response message and may prepare an acknowledgement message if called for by the protocol (e.g. the SIP protocol).

User A's data network telephone 208 also establishes a voice over data channel 284 to permit communication between User A and User B. The voice over data channel 284 is preferably a data communications channel in which voice signals that have been converted to digital information are being carried as data messages in accordance with a selected protocol. The data messages include User B's message 286 and User A's messages 288 as shown in FIG. 5. User B's message 286 and User A's message 288 both include an IP protocol component, a UDP component, an RTP component and a G.72x component.

The IP protocol component permits routing of the messages 286, 288 in accordance with an Internet Protocol (e.g. Ipv4, IPV6, etc.). The UDP component permits transport as a User Datagram in a connection-less environment in accordance

with the User Datagram Protocol (UDP). The RTP component is the chosen format for communicating the voice signals as data. The G.72x component indicates how the voice signals, once extracted from the RTP component are to be processed to produce audio. The G.72x indication represents that the voice signals may conform to ITU-T  
5 Recommendation G.721, ITU-T Recommendation G.722, ITU-T Recommendation G.723, ITU-T Recommendation G.723.1, ITU-T Recommendation G.728 or ITU-T Recommendation G.729. The voice signals may also conform to ITU-T Recommendation G.711 or to any other suitable protocol.

One of ordinary skill in the art will appreciate that the voice over data channel  
10 284 may be implemented using different protocols than the ones shown in FIG. 5. Moreover, when the signaling protocol used to establish the telephone call permits negotiation of supported protocols as is done with the preferred SIP protocol, the voice over data channel 284 may be asymmetrical; that is, User A's messages 288 may be different from User B's messages 286.

15 The telephone call carried out over the voice over data channel 284 proceeds until one or both users terminate the call. During termination or teardown of the call, the telephony connection server 150b performs in accordance with the selected session protocol such as the SIP protocol.

FIGs. 3A-5 show systems and methods for registering and auto-configuring a  
20 data network telephone 208 in accordance with embodiments of the present invention. Those of ordinary skill in the art will appreciate that the systems and methods described above are examples. Other embodiments may fall within the scope of the claims.

#### 25 **D. Methods For Providing Registration and Provisioning of a Data Network Telephone Using A Data Network Telephony System**

FIGs. 6-8 illustrate methods for providing registration and provisioning for a data network telephone that may be performed using any suitable data network telephony system. FIG. 6 is a flowchart showing a method of configuring a data network telephone by registering for service with a service provider. As shown at step  
30 500 in FIG. 6, a data network telephone starts by obtaining an IP address from a DHCP server. At step 502, a request to register message is sent to a service provider server. The service provider server may have a designated default proxy server to use,

or may provide the appropriate server with a call management protocol and/or registration server. In the request to register message, the data network telephone includes a current version of the telephone configuration as shown at step 502. The version of the telephone configuration may include different combinations of the features listed above in Table A.

At step 506, the service provider server 120 (FIG. 1) checks the telephone version with the latest version available. An OR step 506 in the flowchart of FIG. 6 indicates that alternative steps may be taken. At step 507, the service provider server 120 may automatically re-configure the data network telephone. Alternatively, the service provider server may query the user to determine whether to upgrade to a new version at decision block 508. A yes response to the query leads to step 510 to re-configure the data network telephone.

One advantage of registering in the manner shown in FIG. 6 is that a full-function feature laden configuration of the data network telephone is possible using a register request.

FIG. 7 is a flowchart that shows a method for registering the data network telephone with partial or low-level service so that the user may provision the data network telephone as a completely personalized data network telephone. At step 600 in FIG. 7, the data network telephone requests an IP address from a DHCP server. The request to register is sent at step 602 to the default proxy server. At step 604, the user proceeds to a method for provisioning the data network telephone.

FIG. 8 shows a preferred method for provisioning the data network telephone. At step 700, the user connects to the service provider's web page for providing user account information. At step 702, the user enters billing information. At step 704, the user enters user-selectable user identifiers, passwords, email identifiers, etc. At step 706, the user selects features that the user would like to add, and at step 708, the account information is submitted. A confirmatory message and email is received at step 710. When the user responds to the email at step 712, the data network telephone may be used.

While the invention has been described in conjunction with presently preferred embodiments of the invention, persons of skill in the art will appreciate that variations may be made without departure from the scope and spirit of the invention. For



example, the access networks shown in FIG. 2A may comprise any other suitable type of local area network or service infrastructure.

In addition, protocols of various types are referenced throughout. While preferred and alternative embodiments may implement selected protocols, any suitable replacement protocol not mentioned, or any function not part of a protocol used to replace a corresponding function from a protocol may be implemented without departing from the scope of the invention.

This true scope and spirit is defined by the appended claims, interpreted in light of the foregoing.

**WE CLAIM:**

1. A system for providing telephone service comprising:
  - at least one data network telephone connected to a data network operable to provide a plurality of data communications channels, the data network telephone being operable to communicate voice signals as data packets on a voice over data channel, the voice over data channel being one of the plurality of data communications channels on the data network containing packetized voice signals;
  - the data network telephone being operable to convert data packets communicated on the voice over data channel to voice;
  - the data network telephone being operable to perform a plurality of feature enhancements; and
  - a service provider server connected to the data network, the service provider server operable to establish a user interactive connection to obtain a user-selected configuration comprising at least one feature enhancement of the data network telephone.
  
2. The system of Claim 1 wherein the service provider server includes a registration function to automatically configure the data network telephone with a first configuration.
  
3. The system of Claim 1 wherein the service provider server includes a registration function to query a user to determine whether to configure the data network telephone with a second configuration.
  
4. A service provider server comprising:
  - a network interface for communicating over at least one data communications channel;
  - an accounts database for accessing a user account having a user telephone service account for using a data network telephone;

a provisioning function to provide a feature request form to a user on one of the data communications channels, the feature request form being operable to receive user input to select at least one feature enhancement; and  
a service configuration function to send a message to the data network telephone to activate the service enhancements.

10

5. The service provider server of Claim 4 further comprising a web page in the provisioning function to present the feature request form to the user via a web browser.

6. The service provider server of Claim 5 wherein the provisioning function is accessed via an E.164 telephone number.

7. A method for providing a user selected configuration for telephone service using a data network telephone comprising the steps of:

receiving a request to configure the data network telephone from the user;

5

presenting a user feature request form prompting the user to select features;

setting a user account in accordance with the selected features; and  
sending a configuration message to the data network telephone.

8. The method of Claim 7 further comprising the step of sending a confirming message displaying the user selected features.

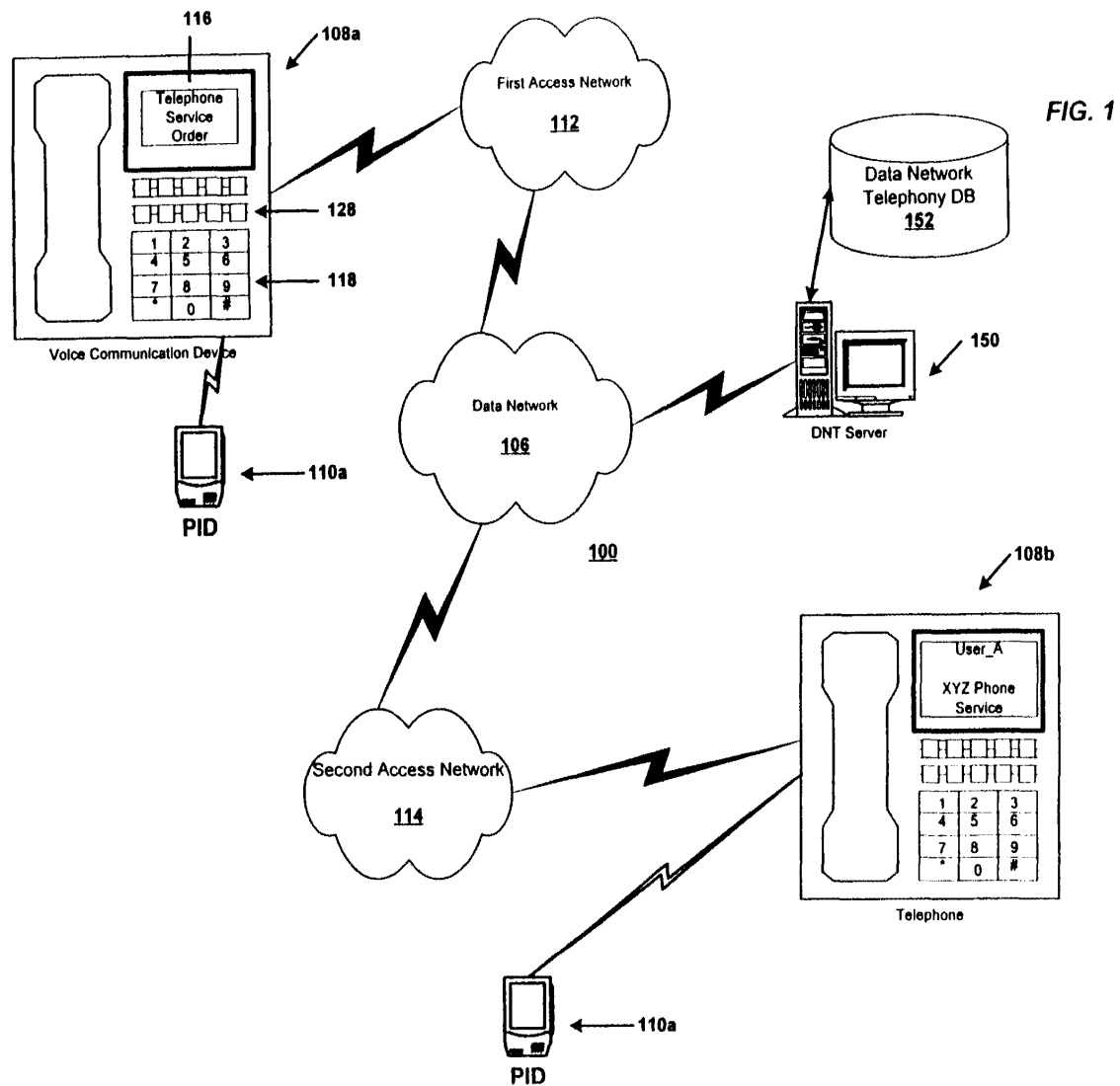


FIG. 1

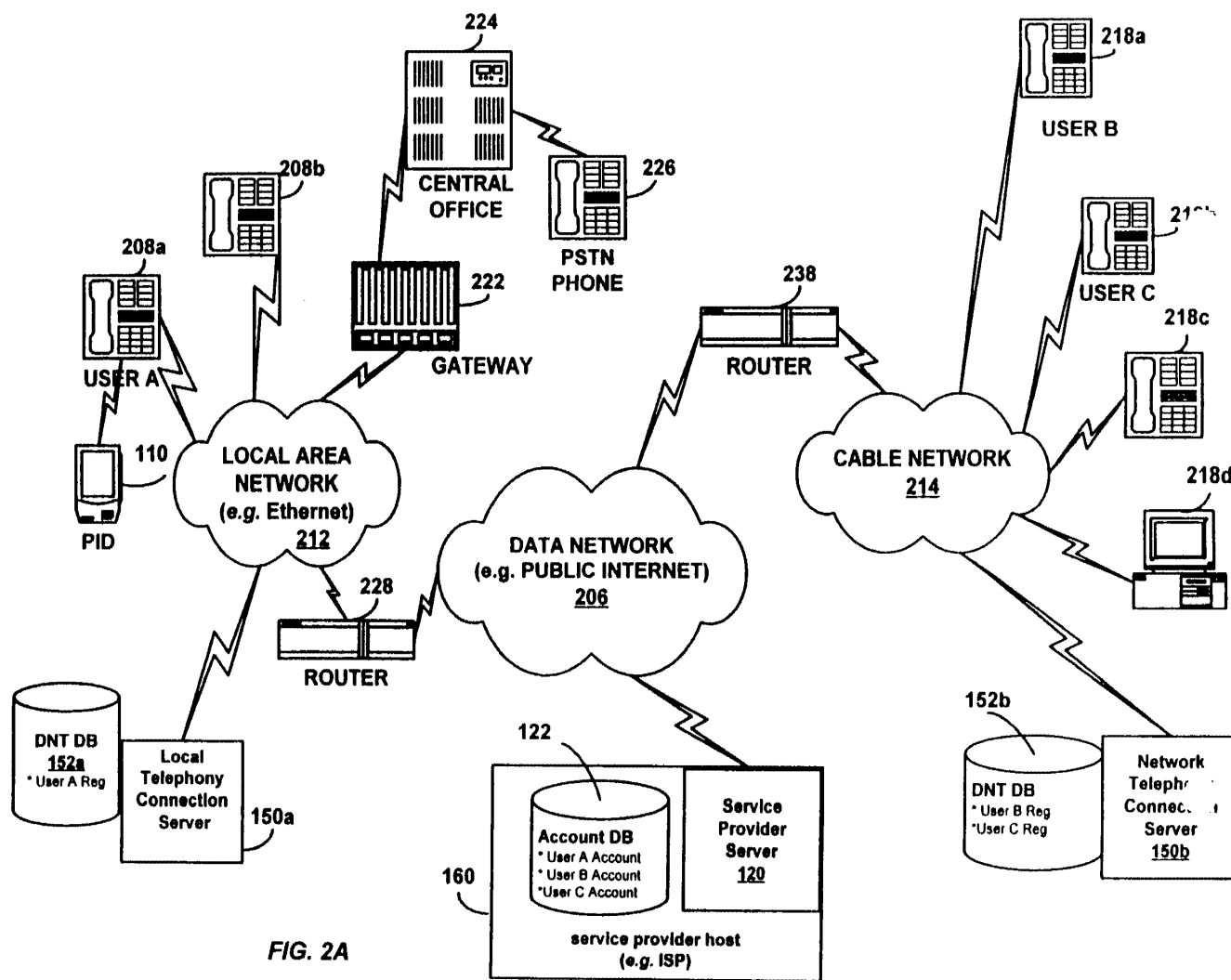


FIG. 2A

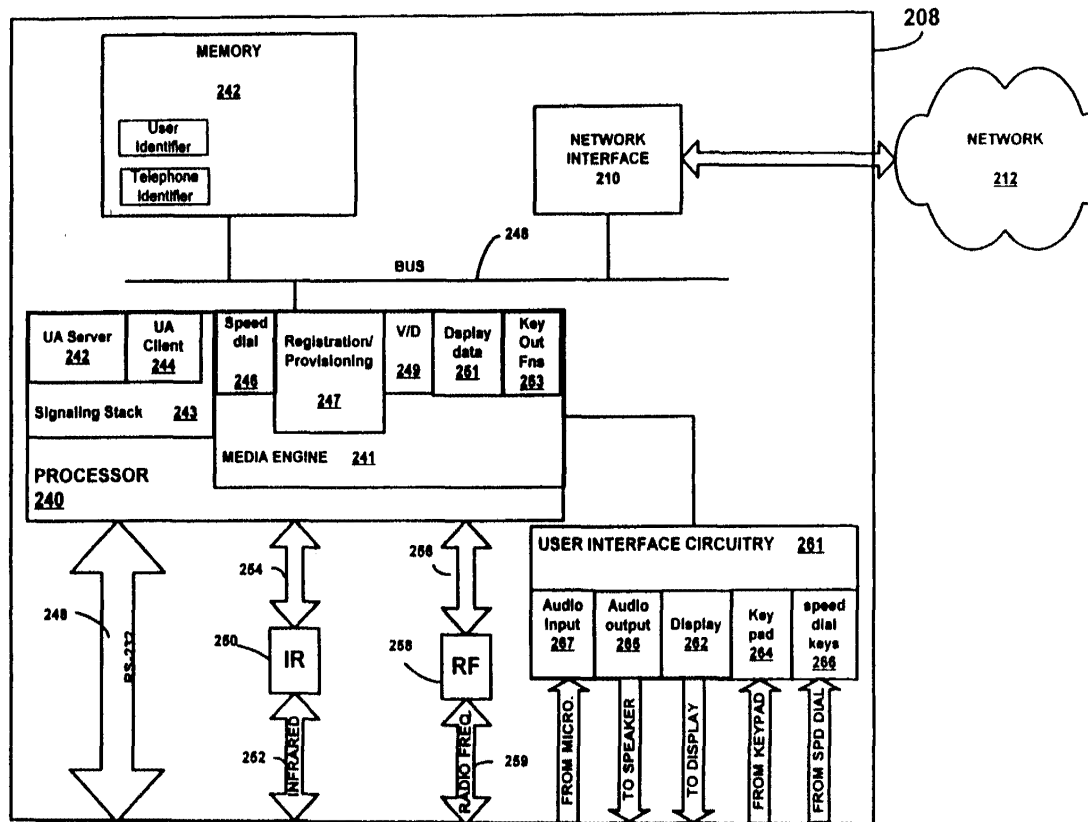
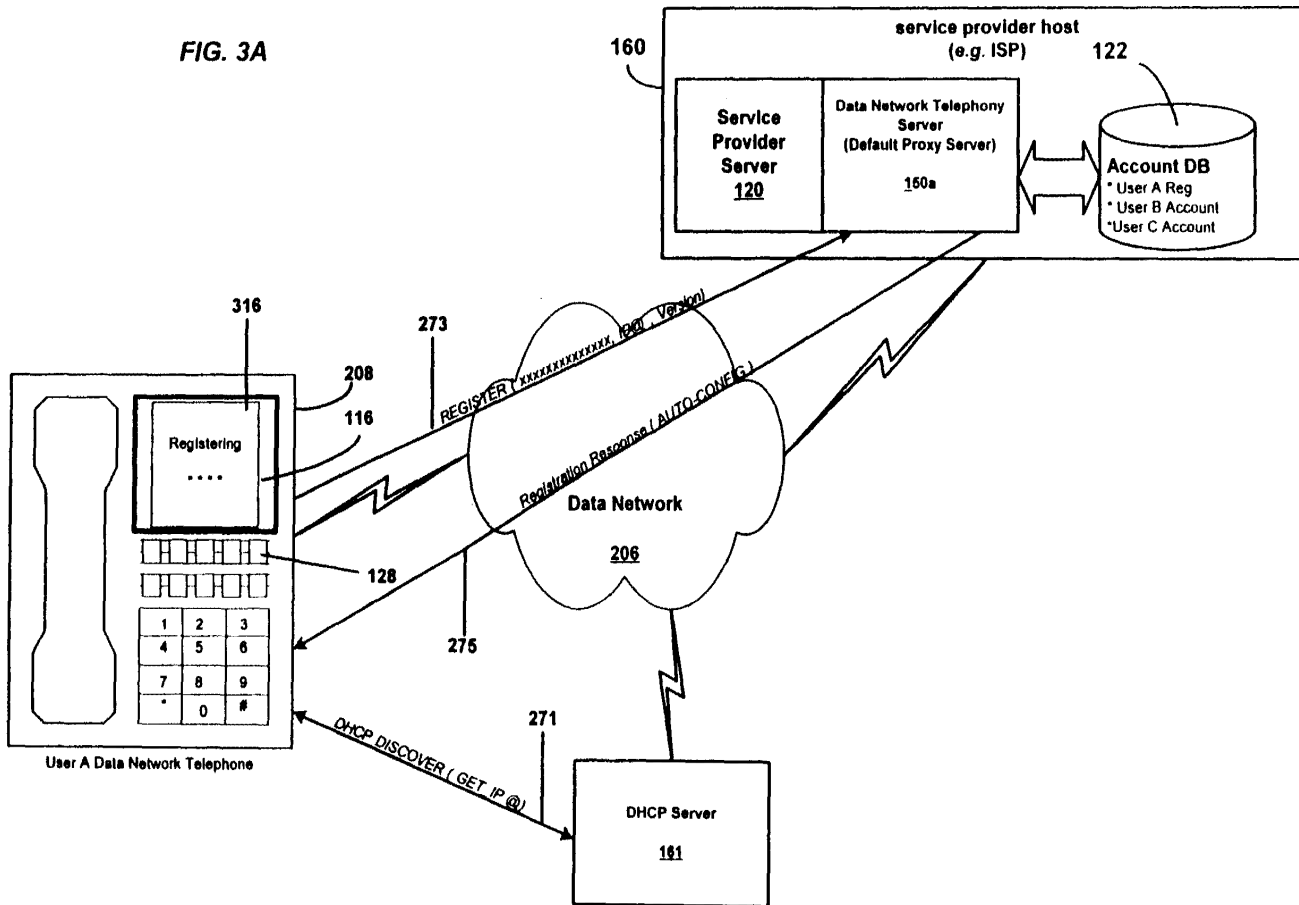


FIG. 2B

FIG. 3A



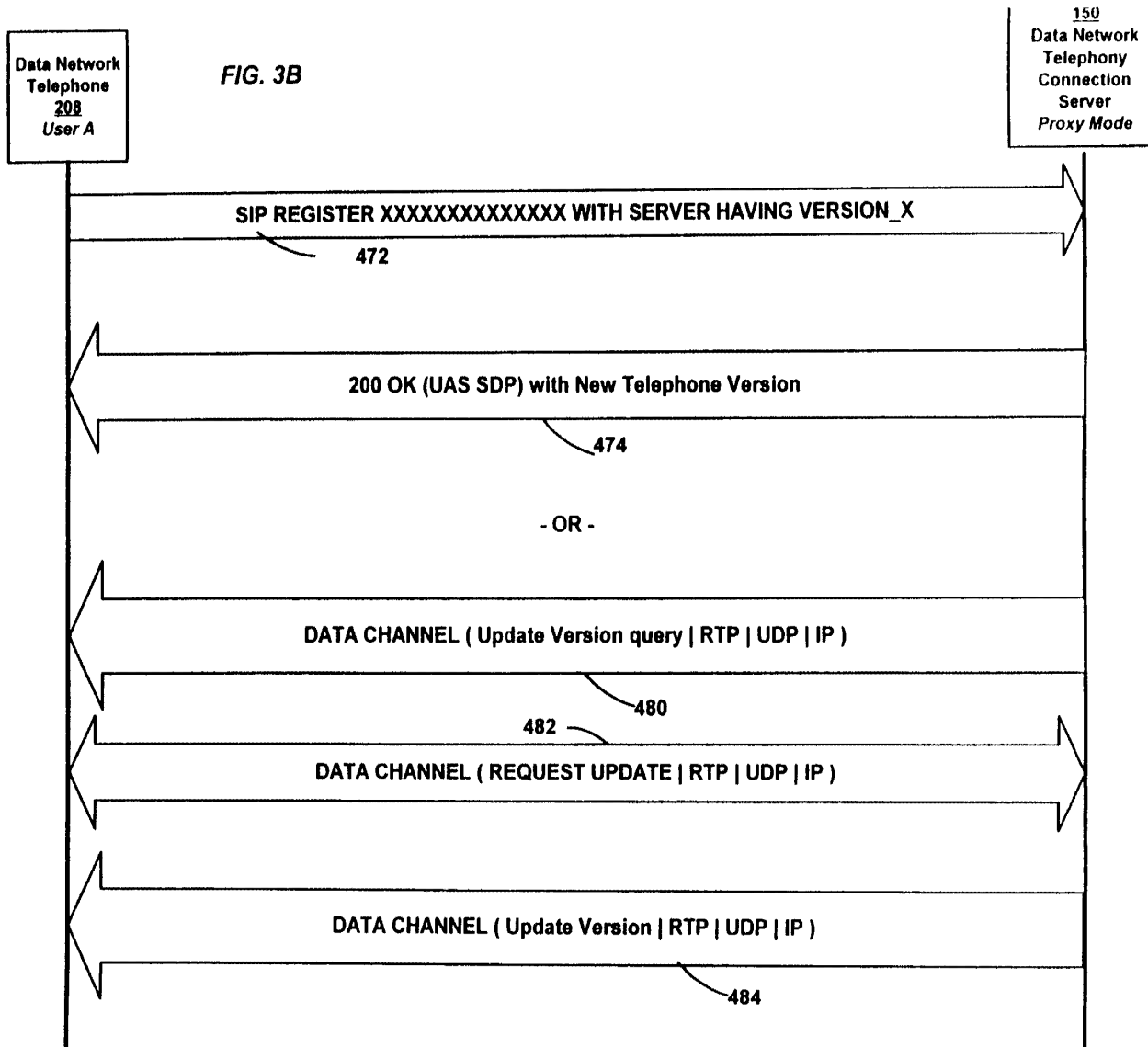




FIG. 3C

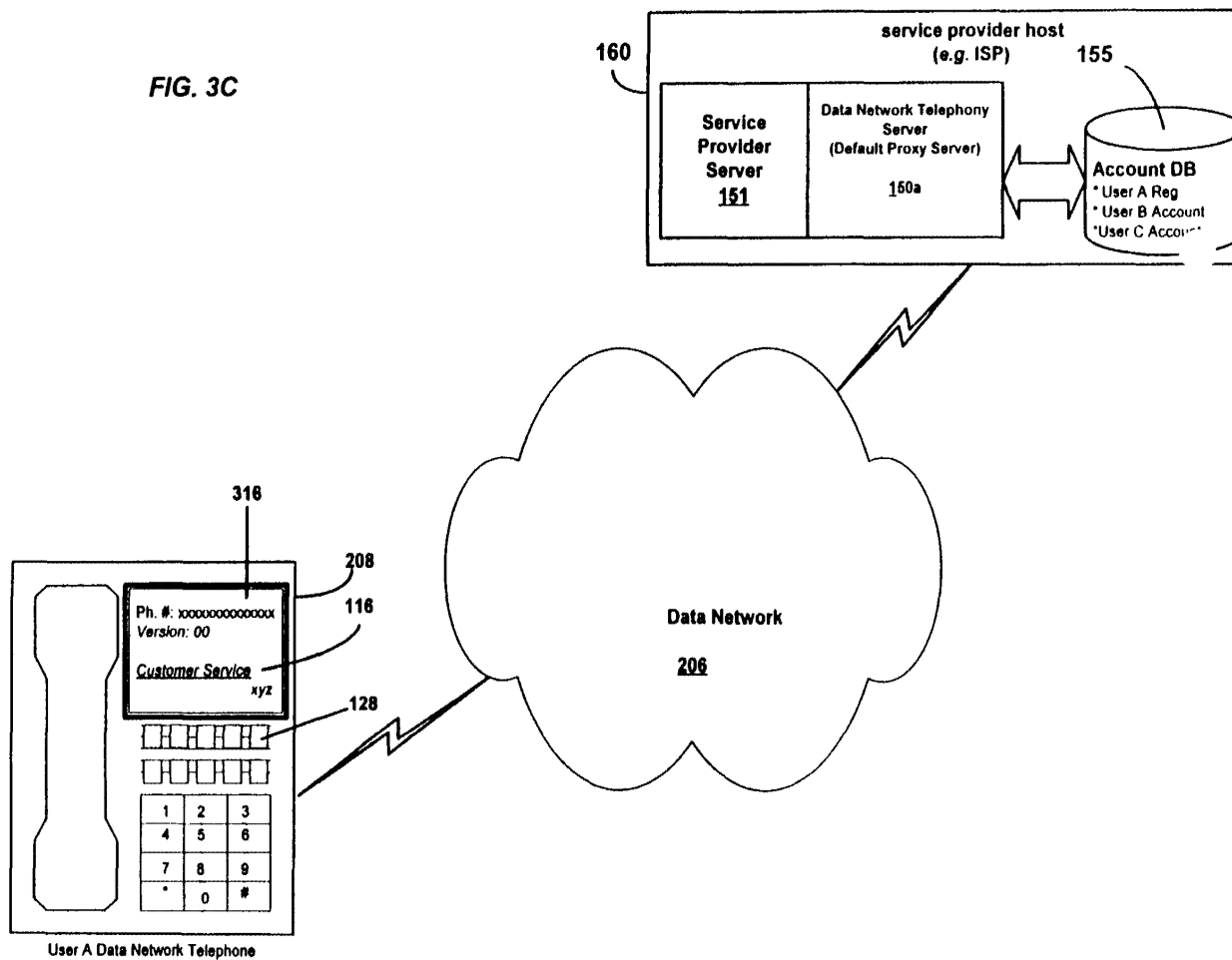


FIG. 4A

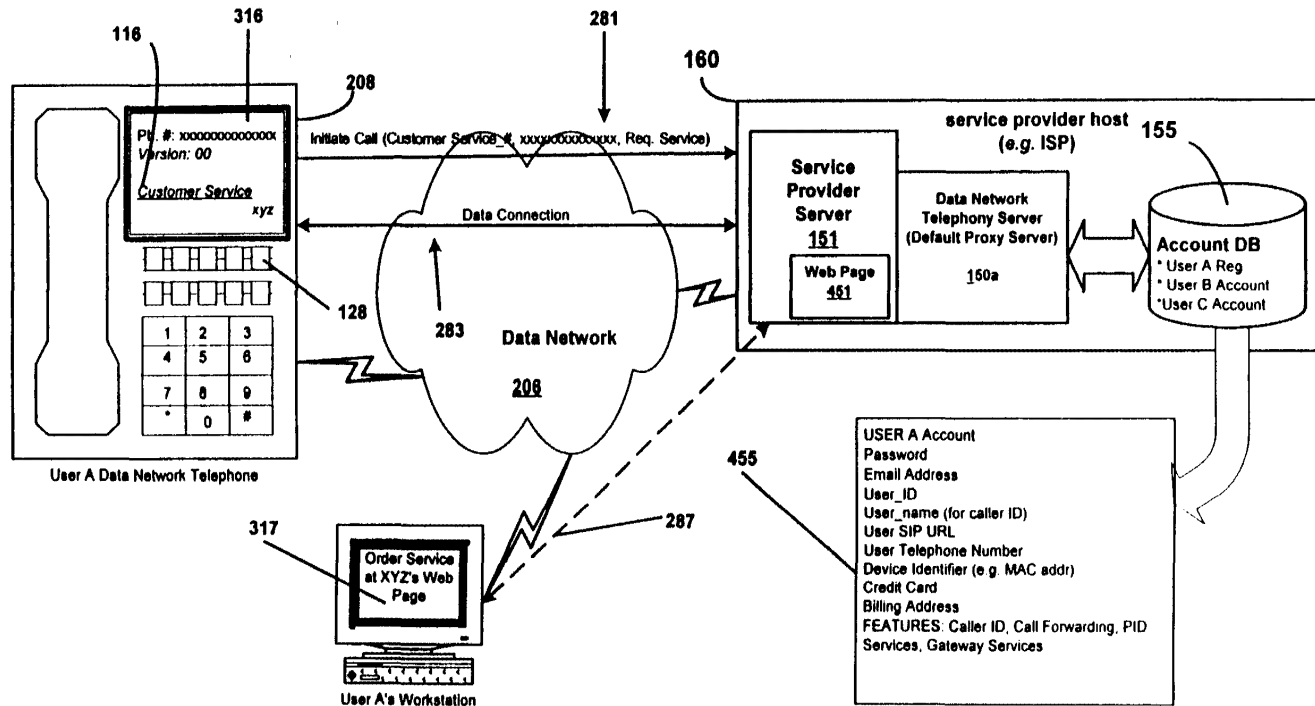


FIG. 4B

317

**New Account**

Welcome to 3Com/(Yahoo!, AOL, MSN, AT&T, MCI, Level 3) Internet Voice Services.  
All 3Com/XXX Internet voice services members can be reached at  
1-800-555-3Com Ext. (provider number)(personal number)

Your personal number can be any number you choose which is not already taken.

Choose your personal number (variable length)

A password:

Re-enter:

A short name for caller ID:

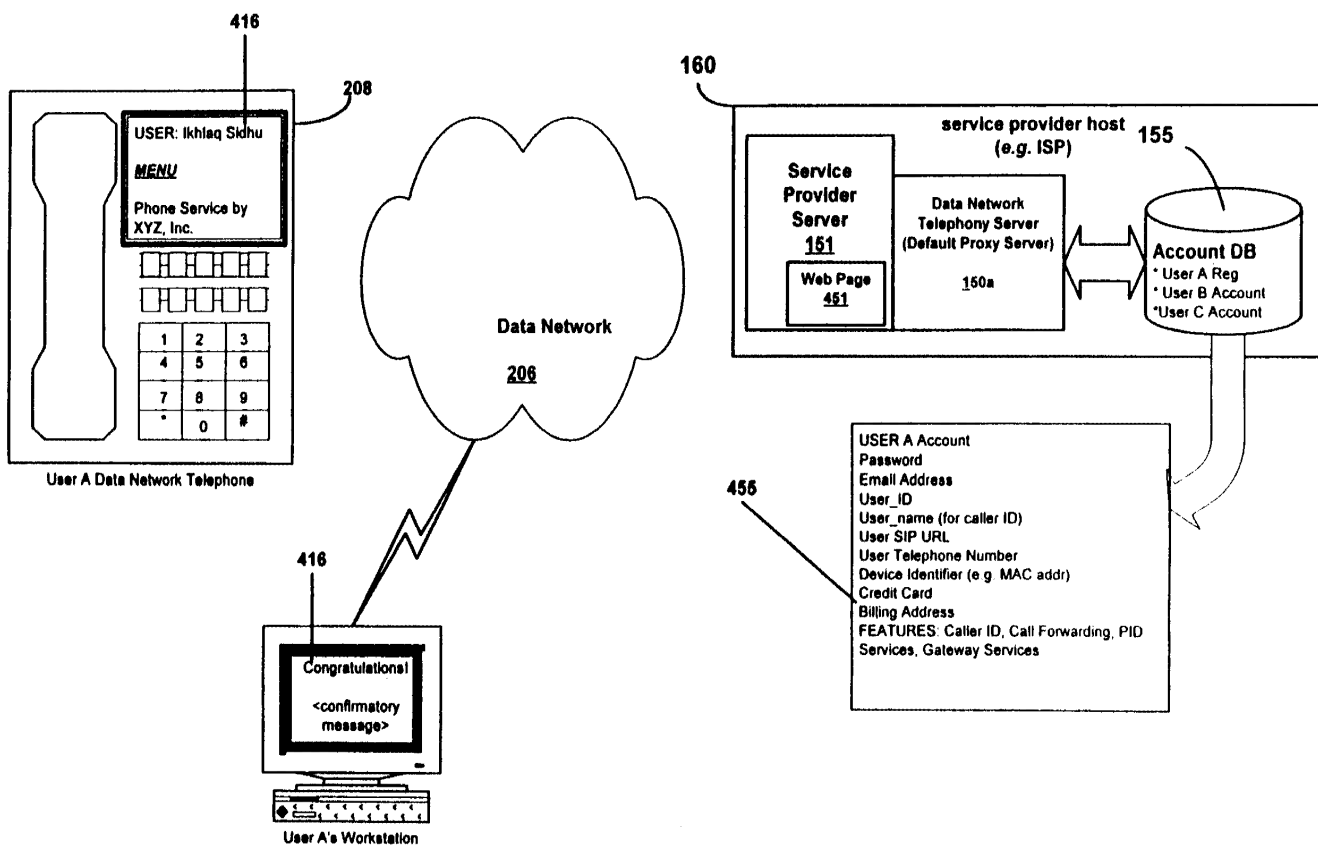
Your e-mail address:

The phone device ID:

A SIP URL: (optional)

A credit card and expiration date:

FIG. 4C



**Congratulations!**

An E-mail has been sent to you. You must reply to that e-mail to activate this account. You should print this page and keep it for future reference.

+ Your new "personal" phone number is 1-800-5553Com                      Ext. 200 634-0610  
+ Your SIP address (for Palm PDA based dialing) is ikhlaq\_sidhu.3com.com@xxx.com

Some Frequently asked questions:

Q: How do I dial another 3Com / XXX Internet phone user?  
A: You only need to dial the extension number. For example other 3Com/(...) users with the same provider code (200) can call you at 634-0610. To call a user with another (say 202) provider number, you must dial 1-202-634-0610.

Q: How do I dial traditional people phones?  
A: Dial 9 to get out of the system. I.e. dial 9, 1800-CALL ATT to use a AT&T calling card

Q: How are calls billed?  
A: There is no extra charge for calls to other 3Com/XXX subscribers.  
There is no extra charge to make domestic long distance calls over the Public Telephone Net. International calls over the public network are billed to your credit card on a per call basis.

Q: How do I set speed dials and other advanced features?  
A: Goto [www.3comvoice.com/ikhlaq\\_sidhu.3com.com@xyz.com](http://www.3comvoice.com/ikhlaq_sidhu.3com.com@xyz.com) and enter your password ZZZ.

Q: How do I use speed dialing from my Palm PDA?  
A: The proxy server option must be set to [proxy@xxx.com](mailto:proxy@xxx.com). Any subscriber with an e-mail address can be auto dialed by . . .

417

FIG. 4D

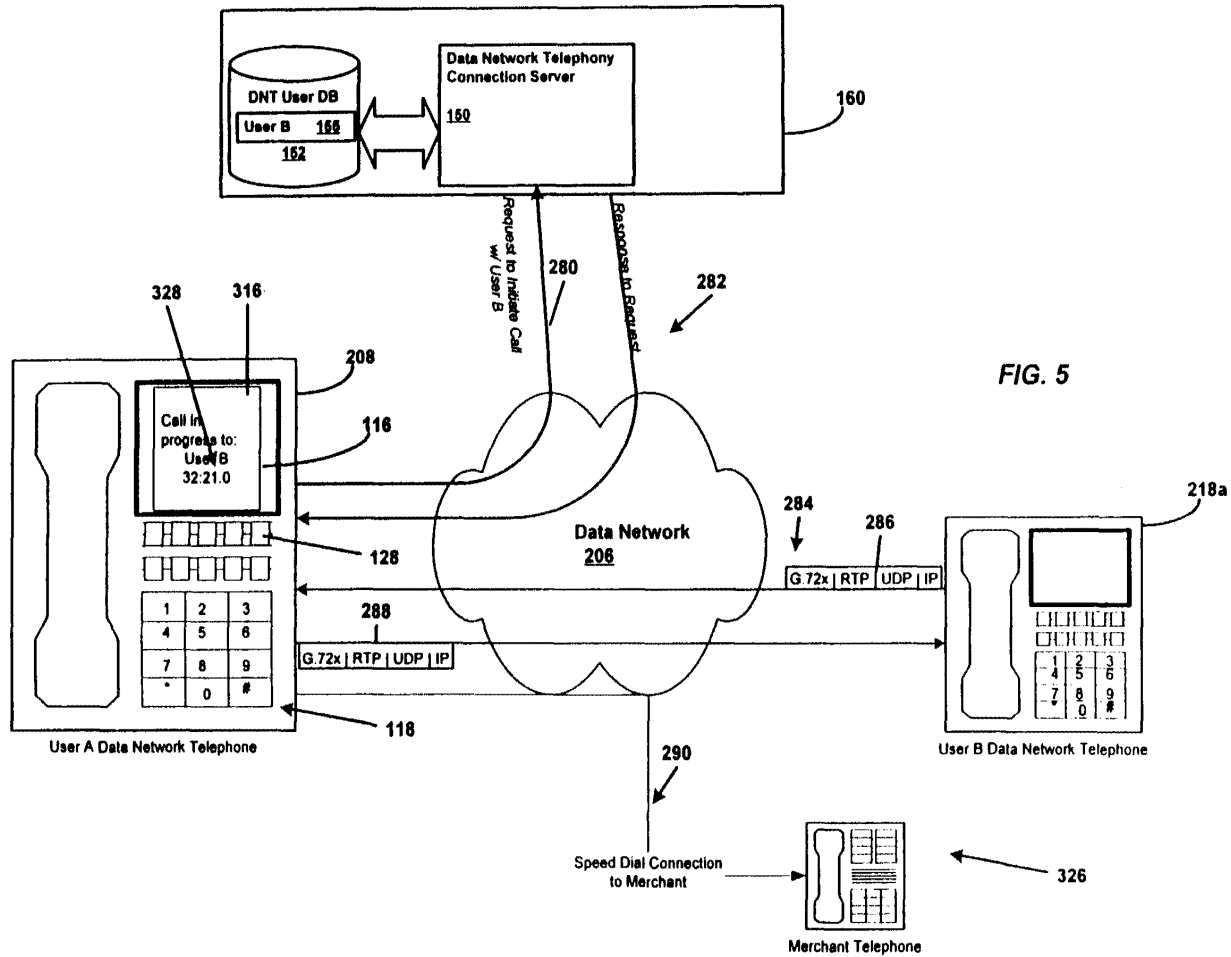
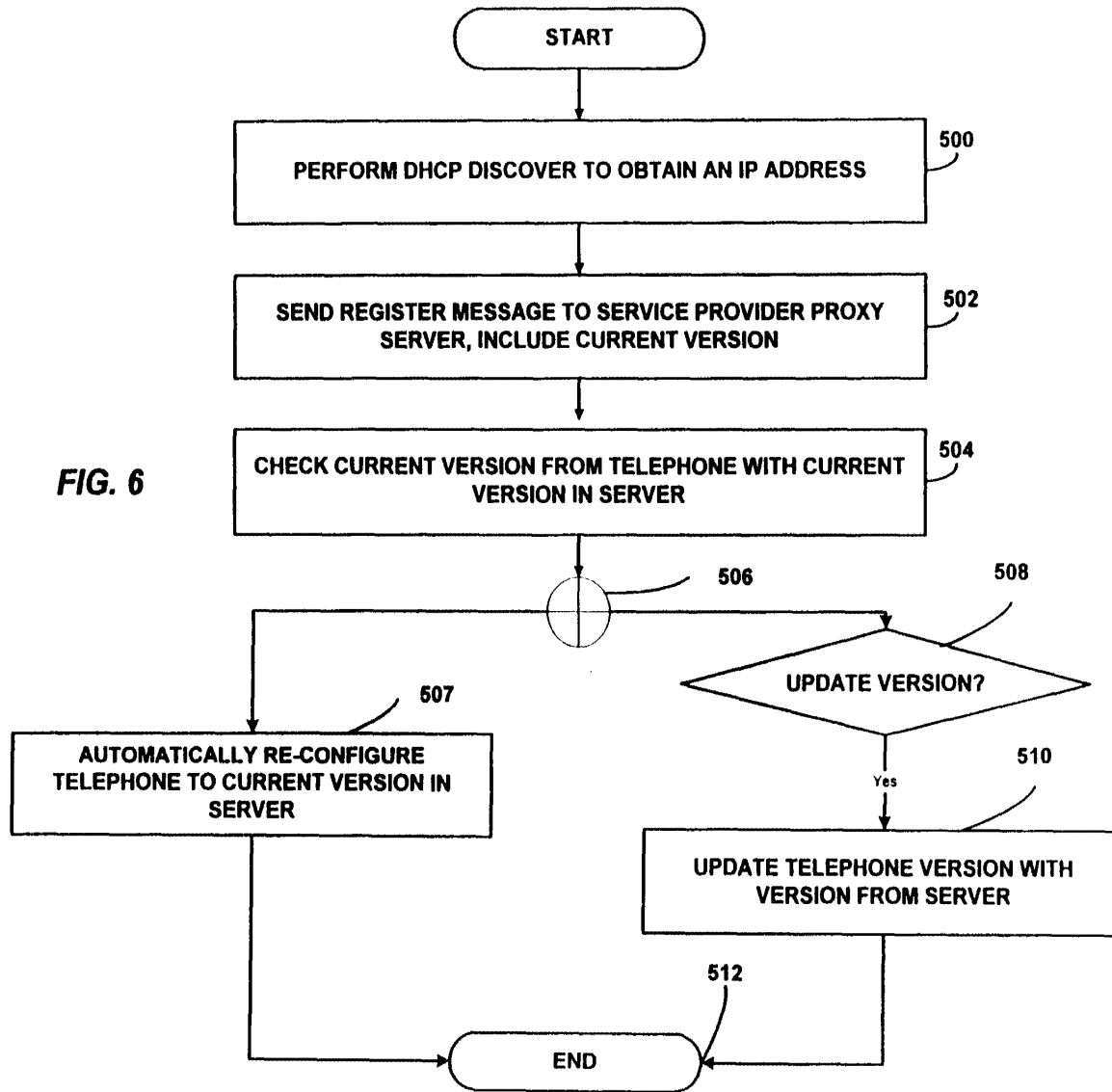


FIG. 5



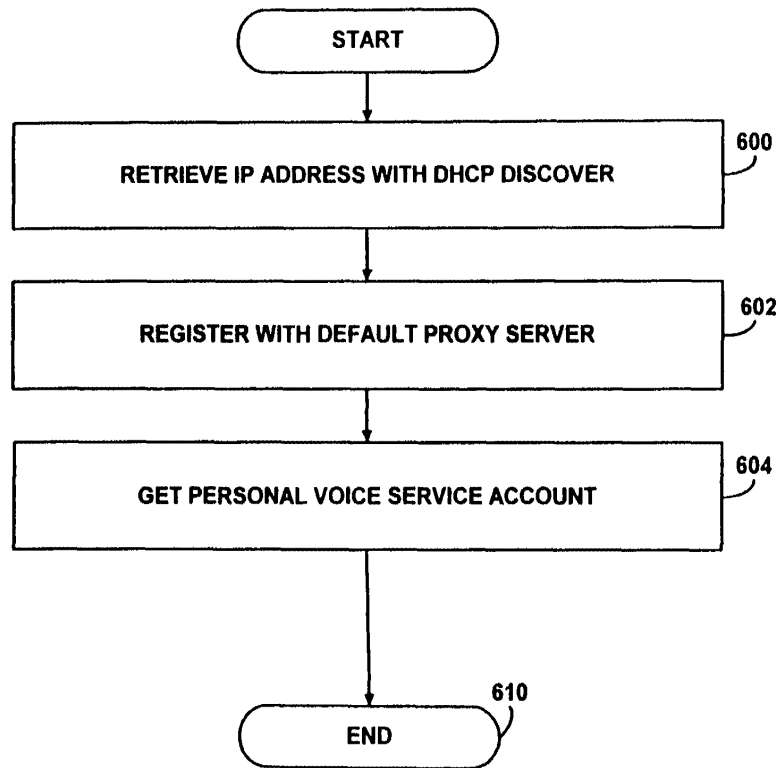


FIG. 7



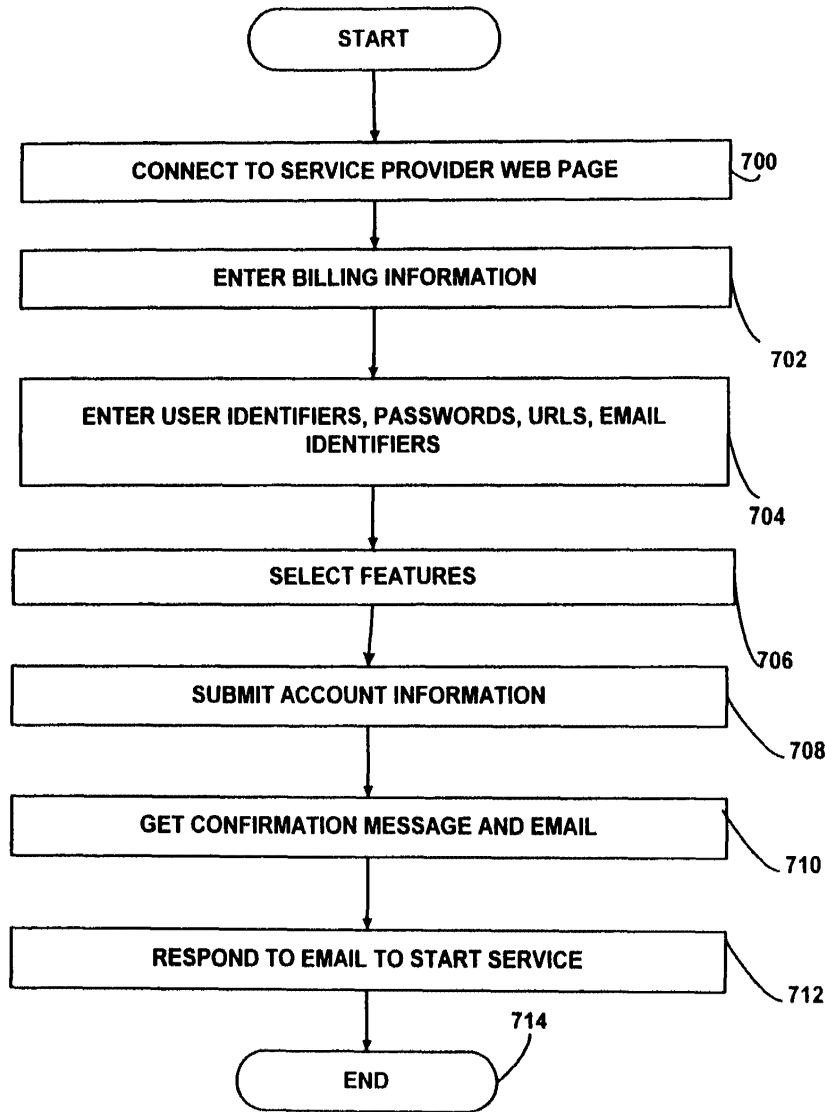


FIG. 8

# INTERNATIONAL SEARCH REPORT

International Application No <b>PCT/US 00/26094</b>
--

<b>A. CLASSIFICATION OF SUBJECT MATTER</b> IPC 7 H04M3/42 H04Q3/00 H04M7/00		
According to International Patent Classification (IPC) or to both national classification and IPC		
<b>B. FIELDS SEARCHED</b>		
Minimum documentation searched (classification system followed by classification symbols) IPC 7 H04M H04Q		
Documentation searched other than minimum documentation to the extent that such documents are included in the fields searched		
Electronic data base consulted during the international search (name of data base and, where practical, search terms used) INSPEC, EPO-Internal, WPI Data		
<b>C. DOCUMENTS CONSIDERED TO BE RELEVANT</b>		
Category *	Citation of document, with indication, where appropriate, of the relevant passages	Relevant to claim No.
X	DALGIC I ET AL: "TRUE NUMBER PORTABILITY AND ADVANCED CALL SCREENING IN A SIP-BASED IP TELEPHONY SYSTEM" IEEE COMMUNICATIONS MAGAZINE, IEEE SERVICE CENTER, PISCATAWAY, N.J, US, vol. 37, no. 7, July 1999 (1999-07), pages 96-101, XP000835310 ISSN: 0163-6804 page 96, left-hand column, line 1 - line 37 page 97, left-hand column, line 46 -page 100, right-hand column, line 45 --- -/--	1-8
<input checked="" type="checkbox"/> Further documents are listed in the continuation of box C.		
<input checked="" type="checkbox"/> Patent family members are listed in annex.		
* Special categories of cited documents :		
*A* document defining the general state of the art which is not considered to be of particular relevance *E* earlier document but published on or after the international filing date *L* document which may throw doubts on priority claim(s) or which is cited to establish the publication date of another citation or other special reason (as specified) *O* document referring to an oral disclosure, use, exhibition or other means *P* document published prior to the international filing date but later than the priority date claimed	*T* later document published after the international filing date or priority date and not in conflict with the application but cited to understand the principle or theory underlying the invention *X* document of particular relevance; the claimed invention cannot be considered novel or cannot be considered to involve an inventive step when the document is taken alone *Y* document of particular relevance; the claimed invention cannot be considered to involve an inventive step when the document is combined with one or more other such documents, such combination being obvious to a person skilled in the art. *&* document member of the same patent family	
Date of the actual completion of the international search	Date of mailing of the international search report	
22 January 2001	31/01/2001	
Name and mailing address of the ISA	Authorized officer	
European Patent Office, P.B. 5818 Patentlaan 2 NL - 2280 HV Rijswijk Tel. (+31-70) 340-2040, Tx. 31 651 epo nl, Fax: (+31-70) 340-3016	Gkeli, M	

1

INTERNATIONAL SEARCH REPORT

International Application No  
PCT/US 00/26094

C.(Continuation) DOCUMENTS CONSIDERED TO BE RELEVANT		
Category *	Citation of document, with indication, where appropriate, of the relevant passages	Relevant to claim No.
Y	US 5 742 905 A (BROCKMAN JAMES JOSEPH ET AL) 21 April 1998 (1998-04-21) column 5, line 28 -column 8, line 53 column 24, line 54 -column 27, line 12 column 29, line 27 -column 33, line 3 column 34, line 10 -column 36, line 51 figures 1-4,21,24,28-45 ----	1-8
Y	WO 98 04065 A (BELL COMMUNICATIONS RES) 29 January 1998 (1998-01-29) page 6, line 9 -page 10, line 2 page 11, line 16 -page 16, line 21 figures 1-3 ----	1-8
X	US 5 838 665 A (HABER ALAN P ET AL) 17 November 1998 (1998-11-17) -----	1-4,7,8
A	column 1, line 66 -column 2, line 27 column 2, line 51 -column 3, line 38 figure 1 -----	5,6

# INTERNATIONAL SEARCH REPORT

Information on patent family members

International Application No

PCT/US 00/26094

Patent document cited in search report	Publication date	Patent family member(s)	Publication date
US 5742905    A	21-04-1998	CA 2199802 A	28-03-1996
		EP 0782805 A	09-07-1997
		JP 9511884 T	25-11-1997
		WO 9609714 A	28-03-1996
		US 5742668 A	21-04-1998
WO 9804065    A	29-01-1998	US 6115737 A	05-09-2000
		CA 2260158 A	29-01-1998
		CN 1226350 A	18-08-1999
		EP 0914731 A	12-05-1999
		JP 11514820 T	14-12-1999
US 5838665    A	17-11-1998	NONE	

(19) World Intellectual Property Organization  
International Bureau



(43) International Publication Date  
5 April 2001 (05.04.2001)

PCT

(10) International Publication Number  
WO 01/24498 A1

- (51) International Patent Classification<sup>7</sup>: H04M 3/56 Hills, IL 60061 (US). **BELKIND, Ronnen**; 1960 Lincoln Park West #2503, Chicago, IL 60614 (US).
- (21) International Application Number: PCT/US00/41020
- (22) International Filing Date: 27 September 2000 (27.09.2000)
- (25) Filing Language: English
- (26) Publication Language: English
- (30) Priority Data: 09/406,128 27 September 1999 (27.09.1999) US
- (71) Applicant: **3COM CORPORATION** [US/US]; 3800 Golf Road, Rolling Meadows, IL 60008 (US).
- (72) Inventors: **SCHUSTER, Guido, M.**; Apartment 408, 1433 Perry Street, Des Plaines, IL 60016 (US). **SIDHU, Sagan, S.**; 403 River Grove Lane, Vernon Hills, IL 60061 (US). **SIDHU, Ikhlq, S.**; 403 River Grove Lane, Vernon Hills, IL 60061 (US).
- (74) Agent: **THYMIAN, Marcus, J.**; McDonnell Boehnen Hulbert & Berghoff, 300 South Wacker Drive, 32nd Floor, Chicago, IL 60606 (US).
- (81) Designated State (*national*): CA.
- (84) Designated States (*regional*): European patent (AT, BE, CH, CY, DE, DK, ES, FI, FR, GB, GR, IE, IT, LU, MC, NL, PT, SE).

**Published:**

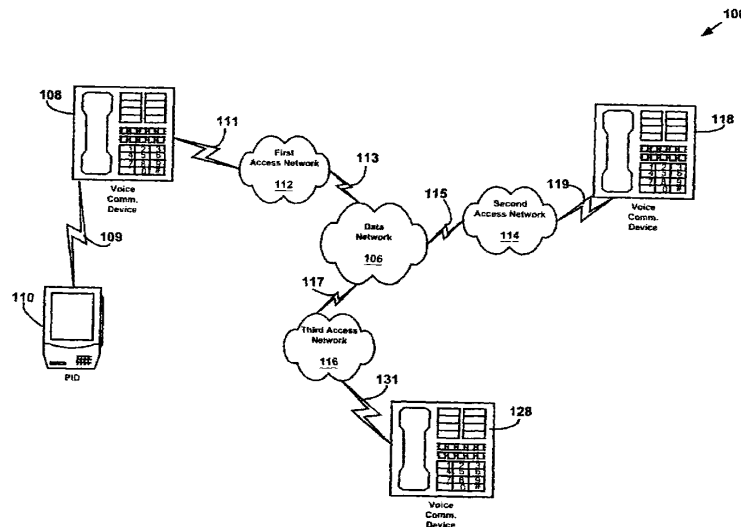
- With international search report.
- Before the expiration of the time limit for amending the claims and to be republished in the event of receipt of amendments.

For two-letter codes and other abbreviations, refer to the "Guidance Notes on Codes and Abbreviations" appearing at the beginning of each regular issue of the PCT Gazette.

(54) Title: SYSTEM AND METHOD FOR ESTABLISHING A CONFERENCE CALL ON A DATA NETWORK TELEPHONY SYSTEM USING A PORTABLE INFORMATION DEVICE



WO 01/24498 A1



(57) Abstract: A system and method for using a portable information device, such as a personal digital assistant, to establish a conference call on a telephony network. In one embodiment, a user of the portable information device may select communication partners from an address book application located in the portable information device. Communication information related to the communication partners is transmitted across a link from the portable information device to a voice communication device, such as a data network telephone. The data network telephone may then set up the conference call.

SYSTEM AND METHOD FOR ESTABLISHING A CONFERENCE CALL ON A DATA NETWORK  
TELEPHONY SYSTEM USING A PORTABLE INFORMATION DEVICE

5

**BACKGROUND OF THE INVENTION****A. Field of the Invention**

The present invention is related to a method and system for providing communication services over a network. In particular, the present invention relates to a system and method for establishing a conference call on a telephony network.

**B. Description of the Related Art**

For many years, telephone service providers on the Public Switched Telephone Network (PSTN) provided their customers nothing more than a telephone line to use to communicate with other subscribers. Over time, telephone service providers have enhanced their service by providing Custom Local Area Signaling Service (CLASS) features to their customers. Similar communication services are provided by a Private Branch Exchange (PBX), which is typically implemented in a nonresidential setting.

The CLASS features permit customer subscribers of the features to tailor their telephone service according to individual needs. Some of the more popular CLASS features are:

- *Call blocking*: The customer may specify one or more numbers from which he or she does not want to receive calls. A blocked caller will hear a rejection message, while the callee will not receive any indication of the call.
- *Call return*: Returns a call to the most recent caller. If the most recent caller is busy, the returned call may be queued until it can be completed.
- *Call trace*: Allows a customer to trigger a trace of the number of the most recent caller.
- *Caller ID*: The caller's number is automatically displayed during the silence period after the first ring. This feature requires the customer's line to be equipped with a device to read and display the out-of-band signal containing the number.
- *Caller ID blocking*: Allows a caller to block the display of their number in a callee's caller ID device.

- *Priority ringing:* Allows a customer to specify a list of numbers for which, when the customer is called by one of the numbers, the customer will hear a distinctive ring.

- *Call forwarding:* A customer may cause incoming calls to be automatically  
5 forwarded to another number for a period of time.

A customer subscriber to a CLASS feature may typically activate and/or deactivate a CLASS feature using "\*" directives (e.g., \*69 to automatically return a call to the most recent caller). CLASS features may also be implemented with the use of out-of-band data. CLASS feature data is typically transmitted between local Class-5  
10 switches using the Signaling System #7 (SS7).

Local Exchange Carriers (LECs) and other similar organizations maintain CLASS offices that typically contain a database entry for each customer. The database allows specification of the CLASS features a customer has subscribed to, as well as information, such as lists of phone numbers, associated with those features. In  
15 some cases, customers may edit these lists on-line via a touch-tone interface. A list of all phone numbers that have originated or terminated a call with each customer is often included in the CLASS office database. For each customer, usually only the most recent number on this list is stored by the local Class-5 switch.

A Private Branch Exchange (PBX), is a stored program switch similar to a  
20 Class-5 switch. It is usually used within a medium-to-large-sized business for employee telephony service. Since a PBX is typically operated by a single private organization, there exists a wide variety of PBX services and features. Custom configurations are common, such as integration with intercom and voice mail systems. PBX's typically support their own versions of the CLASS features, as well as  
25 other features in addition to those of CLASS. Most PBX features are designed to facilitate business and group communications.

A summary of typical PBX features includes:

- *Call transfer:* An established call may be transferred from one number to another number on the same PBX.
- *Call forwarding:* In addition to CLASS call forwarding, a PBX number can be  
30 programmed to automatically transfer a call to another number when the first number does not answer or is busy.

- *Camp-on queuing*: Similar to PSTN call return, a call to a busy number can be queued until the callee can accept it. The caller can hang up their phone and the PBX will ring them when the callee answers.
- *Conference calling*: Two or more parties can be connected to one another by dialing into a conference bridge number.
- *Call parking*: An established call at one number can be put on hold and then reestablished from another number. This is useful when call transfer is not warranted.
- *Executive override*: A privileged individual can break into an established call. After a warning tone to the two participants, the call becomes a three-way call.

10           While the CLASS and PBX features have enhanced the offerings of service providers that use the PSTN, the features are nevertheless limited in their flexibility and scope. The effect to the user is that the features become clumsy and difficult to use. For example, in order to use the Call Forwarding function, the user must perform the steps at the user's own phone prior to moving to the location of the  
15           telephone to which calls will be forwarded. A more desirable approach, from the standpoint of usefulness to the user, would be to perform the steps at the telephone to which calls will be forwarded.

          Much of the lack of flexibility of the PSTN features is due to the lack of flexibility in the PSTN system itself. One problem with the PSTN is that the terminal  
20           devices (*e.g.* telephones) lack intelligence and operate as "dumb" terminals on a network having the intelligence in central offices. Most PSTN telephones are limited in functional capability to converting the analog signals they receive to sound and converting the sound from the handset to analog signals.

          Some PSTN telephones have a display device and a display function to display  
25           specific information communicated from intelligent agents in the PSTN network using the PSTN signaling architecture. For example, some PSTN telephones have a display function to enable the Caller ID feature. Even such PSTN telephones are limited however by the closed PSTN signaling architecture, which prohibits access by the PSTN telephones to the network signaling protocols. The display functions are  
30           effectively limited to displaying text, again, as a "dumb" terminal.

          The Internet presents a possible solution for distributing intelligence to telephony terminal devices. In Internet telephony, digitized voice is treated as data and transmitted across a digital data network between a telephone calls' participants. One form of Internet telephony uses a telephony gateway/terminal where IP telephony



calls are terminated on the network. PSTN telephones are connected by a subscriber line to the gateway/terminal at the local exchange, or at the nearest central office.

This form of Internet telephony provides substantial cost savings for users. Because the PSTN portion used in Internet telephony calls is limited to the local lines on each  
5 end of the call, long distance calls may be made for essentially the cost of a local call. Notwithstanding the costs savings provided by this form of Internet telephony, it is no more flexible than the PSTN with respect to providing enhancements and features to the basic telephone service.

In another form of Internet telephony, telephones are connected to access  
10 networks that access the Internet using a router. The telephones in this form of Internet telephony may be substantially more intelligent than typical PSTN telephones. For example, such a telephone may include substantially the computer resources of a typical personal computer.

Data network telephones and the data network (*e.g.* Internet) system in which  
15 they operate, however, lack a substantial infrastructure and service providers for providing telephone service.

It would be desirable to incorporate CLASS and PBX features into a data network telephony system that uses a data network such as the Internet.

It would be desirable to provide new features and enhancements to telephony  
20 service that accommodates and conforms to users' needs.

It would also be desirable to provide features and capabilities to telephone service that create new opportunities for users and for service providers.

The present invention addresses the above needs by providing a system in a data network telephony system, such as for example, the Internet, that enables a PID  
25 (Portable Information Device) user to establish a conference call on a telephony network.

**BRIEF DESCRIPTION OF THE DRAWINGS**

Presently preferred embodiments of the invention are described below in conjunction with the appended drawing figures, wherein like reference numerals refer to like elements in the various figures, and wherein:

5           FIG. 1 is block diagram of a network telephony system according to one embodiment of the present invention;

          FIG. 2 is a block diagram showing a system for establishing a conference call on a telephony network according to an exemplary embodiment of the present invention;

10          FIG. 3 is a block diagram of a data network telephone according to an exemplary embodiment of the present invention;

          FIG. 4 is a block diagram of a portable information device (PID) according to an exemplary embodiment of the present invention;

          FIG. 5 is a stack layer diagram showing the layers of an IrDA stack;

15          FIG. 6 is a block and stack layer diagram illustrating the protocol stacks in an exemplary embodiment of a PID linked to a data network telephone;

          FIG. 7 is block and stack layer diagram illustrating an embodiment of the present invention in which a SIP call may be established;

          FIG. 8A is a block and message flow diagram showing a system for  
20 establishing a conference call on a telephony network, according to a first embodiment of the present invention;

          FIG. 8B is a message flow diagram showing an exemplary flow of messages in a system for establishing a conference call on a telephony network, according to a first embodiment of the present invention;

25          FIG. 9A is a block and message flow diagram showing a system for establishing a conference call on a telephony network, according to a second embodiment of the present invention;

          FIG. 9B is a message flow diagram showing an exemplary flow of messages in a system for establishing a conference call on a telephony network, according to a  
30 second embodiment of the present invention;

          FIG. 10A is a block and message flow diagram showing a system for establishing a conference call on a telephony network, according to a third embodiment of the present invention;

FIG. 10B is a message flow diagram showing an exemplary flow of messages in a system for establishing a conference call on a telephony network, according to a third embodiment of the present invention;

FIG. 11 is a pictorial diagram showing an exemplary display screen of a PID displaying entries from an address book application according to one embodiment of the present invention; and

FIG. 12 is a pictorial diagram showing an exemplary display screen of a PID displaying a conference call attempt according to one embodiment of the present invention.

10

**DETAILED DESCRIPTION OF THE PREFERRED EMBODIMENT**

The following references to patent applications filed concurrently herewith are incorporated by reference:

- 5 \* “System and Method for Controlling Telephone Service Using a Wireless Personal Information Device” to Schuster, et al., Serial No. 09/406,321
- \* “System and Method for Advertising Using Data Network Telephone Connections” to Schuster, et al., Serial No. 09/406,320
- \* “System and Method for Providing User-Configured Telephone Service in a Data Network Telephony System” to Sidhu, et al., Serial No. 09/405,283
- 10 \* “System and Method for Accessing a Network Server Using a Portable Information Device Through a Network Based Telecommunication System” to Schuster, et al., Serial No. 09/406,322
- \* “System and Method for Interconnecting Portable Information Devices Through a Network Based Telecommunication System” to Schuster, et al.,  
15 Serial No. 09/406,152
- \* “System and Method for Enabling Encryption on a Telephony Network” to Schuster, et al., Serial No. 09/405,981
- \* “System and Method for Associating Notes with a Portable Information Device on a Network Telephony Call” to Schuster, et al., Serial No.  
20 09/406,151
- \* “System and Method for Providing Shared Workspace Services Over a Telephony Network” to Schuster, et al., Serial No. 09/406,298
- \* “System and Method for Providing Service Provider Configurations for Telephones in a Data Network Telephony System” to Schuster, et al., Serial  
25 No. 09/406,066

The following additional references are also incorporated by reference herein:

- \* “Multiple ISP Support for Data Over Cable Networks” to Ali Akgun, et al.,  
Serial No. 09/321,941
- \* “Method and System for Provisioning Network Addresses in a Data-Over-  
30 Cable System” to Ali Akgun, et al., Serial No. 09/218,793.
- \* “Network Access Methods, Including Direct Wireless to Internet Access” to Yingchun Xu, et al., Serial No. 08/887,313

### A. PID-Enabled Data Network Telephony System

FIG. 1 is a block diagram showing an exemplary embodiment of a system 100 for establishing a conference call on a telephony network according to the present invention. The system includes a data network 106. A first voice communication  
5 device 108 linked to a first access network 112 via connection 111 may communicate over the data network 106 by connecting via the first access network 112. A second voice communication device 118 is linked to a second access network 114 through connection 119 and may communicate over the data network 106 by connecting via the second access network 114. A third voice communication device 128 is linked to  
10 a third access network 116 through connection 131 and may communicate over the data network 106 by connecting via the third access network 116.

The data network 106 in the system 100 typically includes one or more Local Area Networks (LANs) connected to one another or to a Wide-Area Network (WAN), such as an Internet Protocol (IP) network, to provide wide-scale data connectivity.  
15 The data network 106 may use Voice-Over-Packet (VOP) schemes in which voice signals are carried in data packets. The network 106 may also include a connection to the Public Switched Telephone Network (PSTN) to allow for voice connections using traditional circuit switching techniques. In one embodiment, the data network 106 may include one or more LANs such as Ethernet LANs and support data transport  
20 protocols for performing Voice-over-Internet-Protocol (VoIP) techniques on the Internet. For further details regarding VoIP, see the information available through the Internet Engineering Task Force (IETF) at [www.ietf.org](http://www.ietf.org). In addition, an Internet Telephony gateway may be included within the system 100 to allow for voice connections to users connected by subscriber lines at a PSTN Central Office. Other  
25 data besides voice may also be communicated over the data network 106.

The voice communication devices 108, 118, and 128 typically include a voice input, a voice output, and a voice processing system (described further below with reference to FIG. 3). The voice processing system converts voice sound to digital data signals that are communicated on a voice connection over the data network. The  
30 voice processing system also converts digital data signals received from the voice connection to voice sound. The voice communication devices 108, 118, and 128 typically include a central processing unit and memory to store and process computer programs. Additionally, each voice communication device typically includes a

unique network address, such as an IP address, in memory to uniquely identify it to the data network 106 and to permit data packets to be routed to the device.

A PID 110 linked to the first voice communication device 108 via link 109 may communicate over the data network 106 by connecting via the first access  
5 network 112. The PID 110 includes user attributes stored in a user information data base. The user attributes may contain such information as a user identifier, schedule information, information about contacts, and other information that is associated with a user of the PID 110. The PID 110 includes a user interface allowing a user to easily enter and retrieve data. In a preferred embodiment, the user interface includes a  
10 pressure-sensitive display that allows a user to enter input with a stylus or other device. An example of a PID with such an interface is a PDA (Personal Digital Assistant), such as one of the Palm™ series of PDAs offered by 3Com® Corporation. The PID 110 may include other functionality, such as wireless phone or two-way radio functionality.

15 Link 109 is a point-to-point link, and may be entirely or partially wireless, or may be a hard-wired connection. Preferably, the link 109 is a wireless link, such as an infrared link specified by the Infrared Data Association (IrDA) (see [www.irda.org](http://www.irda.org) for further information) or a radio frequency (RF) link such as the Bluetooth system (see [www.bluetooth.com](http://www.bluetooth.com) for further information). However, the point-to-point link  
20 can also be a hardwired connection, such as an RS-232 serial port connection.

In one embodiment, the voice communication device 108 includes a handset with a receiver and transmitter similar or identical to handsets of traditional circuit-switched telephones. A console on which the handset sits may include the voice processing system, a display 116, and a keypad 118, for example.

25 In a preferred embodiment, a portion of the voice communication device 108 utilizes an NBX 100™ communication system phone offered by 3Com® Corporation. In alternative embodiments, the voice communication device 108 may include any device having voice communications capabilities. For example, a personal computer having a microphone input and speaker output may also be used to implement the  
30 voice communication device 108. Other configurations are also intended to be within the scope of the present invention.

The details relating to operation of the voice communication devices 108, 118, and 128 depend on the nature of the data network 106 and the nature of the access networks 112, 114, and 116 connecting the voice communication devices 108, 118,

and 128 to each other and/or to other network entities. The access networks 112, 114, and 116 typically include any high bandwidth network adapted for data communications, i.e. a network having greater than 64,000 bits-per-second (bps) bandwidth. The access networks 112, 114, and 116 may link to the voice communication devices 108, 118, and 128 using an Ethernet LAN, a token ring LAN, a coaxial cable link (e.g. CATV adapted for digital communication), a digital subscriber line (DSL), twisted pair cable, fiberoptic cable, an integrated services digital network (ISDN) link, and wireless links, for example. In embodiments that may not require bandwidth greater than 64,000 bps, the access networks 112, 114, and 116 may also include the PSTN and link the voice communications devices 108, 118, and 128 by an analog modem. Further details regarding specific implementations are described below, with reference to FIGs. 2 through 13.

#### **B. System for Establishing a Conference Call on a Data Network Telephony System**

One advantage of the PDA-Enabled Data Network Telephony System 100 in FIG. 1 is that it may be used to establish conference calls between users on the Data Network Telephony System. In one embodiment, the PID 110 allows a user to select the communications partners to be included in the conference call. The PID 110 then transfers information about the communications partners to first voice communication device 108 through the link 109. The first voice communication device 108 then sets up the conference call with voice communication devices associated with the communication partners selected by the user associated with the first voice communication device 108.

Once a conference call is set up, data can be transferred between the conferenced voice communication devices. PIDs, such as the PID 110, associated with the parties to the conference call may also be used to communicate information. For example, the PID 110 linked to the first voice communication device 108 may be able to accept and display PID data entered by a user through a user interface on the PID 110. The PID data can then be communicated across the link 109 to the voice communication device 108 for transport across the first access network 112, the data network 106, and the second and third access networks 114 and 116 to the second and third voice communication devices 118 and 128. The PID 110 can also receive PID data and other data across the link 109 for display on the PID 110. A voice-over-data

channel for communicating voice-over-data can concurrently exist with this communication of PID data over a PID data channel. Preferably, all parties to the conference call have PIDs linked to the voice communication devices associated with the parties. In this way, a user of the PID 110 can communicate PID data to other parties to the conference call while voice signals are communicated between the voice communication devices.

#### 1. Local Area Networks as an Exemplary Access Networks

FIG. 2 is a block diagram showing one example of the system 100 of FIG. 1 for establishing a conference call on a telephony network according to the present invention. The system 200 in FIG. 2 includes a local area network 212 connected to a data network 206 by a first router 213. A second local area network 214 is connected to the data network 206 by a second router 215. A cable network 216 is connected to the data network 206 by a third router 217. Those of ordinary skill in the art will appreciate that while FIG. 2 illustrates the access networks as two local area networks 212 and 214, and a cable network 216, any other type of network may be used. For example, the local area networks and the cable network may be replaced by ISDN, DSL, or any other high-speed data link.

The local area networks 212 and 214 provide data connectivity to their respective network elements. For example, the first LAN 212 provides data connectivity to at least a first data network telephone 208 and a first network telephony connection server 250. The second LAN 214 provides data connectivity to at least a second data network telephone 218 and a second network telephony connection server 238. The local area networks 212 and 214 in FIG. 2 are, for example, Ethernet LANs operating according to the IEEE 802.3 specification, which is incorporated by reference herein; however, other types of local area networks may also be used. The first local area network 212 uses the router 213 to provide the first data network telephone 208 and the first network telephony connection server 250 with access to the data network 206. For example, the router 213 may perform routing functions using protocol stacks that include the Internet Protocol and other protocols for communicating on the Internet. Similarly, the second local area network 214 uses the router 215 to provide the second data network telephone 218 and the second network telephony connection server 238 with access to the data network 206.



The first, second, and third network telephony connection servers 250, 238, and 237 provide telephony registration, location and session initiation services for voice connections in which at least one of their members are a party. For example, a user of the first data network telephone 208 may register for telephony service with an administrator of the first network telephony connection server 250 and receive a user identifier and a telephone identifier. The user identifier and telephone identifier may be sequences of unique alphanumeric elements that callers use to direct voice connections to the user. The network telephony connection servers 250, 238 and 237 register users by storing user records in registration databases (not shown in FIG. 2) associated with each of the network telephony connection servers 250, 238 and 237, in response to registration requests.

The call setup process and the user and telephone identifiers preferably conform to requirements defined in a call-management protocol. The call-management protocol is used to permit a caller anywhere on the data network to connect to the user identified by the user identifier in a data network telephone call. A data network telephone call includes a call setup process and a voice exchange process. The call setup process includes steps and message exchanges that a caller and callee perform to establish the telephone call. The actual exchange of voice signals is performed by a data communications channel. The data communications channel incorporates other data transport and data formatting protocols, and preferably includes well-known data communications channels typically established over the Internet.

The call management protocol used in FIG. 2 is the Session Initiation Protocol (SIP), which is described in M. Handley et al., "SIP: Session Initiation Protocol," IETF RFC 2543, Mar. 1999, incorporated by reference herein; however, any other such protocol may be used. Other protocols include H.323, MEGACO, the Media Gateway Control Protocol (MGCP), etc.

The network telephony connection servers 250, 238, and 237 may be used to provide telephony service for mobile users. For example, a user may be registered to use the first network telephone 208 (which is identified by its telephone identifier), but the user may move to a location near a second network telephone (not shown) on the first local area network 212. The user may re-register as the user of the second telephone. Calls that identify the user by the user's user identifier may then reach the user at the second network telephone.

## 2. Cable Network as an Exemplary Access Network

The system 200 in FIG. 2 also shows a cable network 216 connected to the data network 206 by a router 217. The cable network 216 provides data network access to its network elements, which in FIG. 2 include a third data network telephone 228 and a third network telephony connection server 237. A user of the third data network telephone 218 connected to the cable network 216 may communicate by telephone over the data network 206 with the users of the first and second data network telephones 208 and 218 respectively connected to the first and second local area networks 212 and 214.

The cable network 216 includes any digital cable television system that provides data connectivity. In the cable network 216, data is communicated by radio frequency in a high-frequency coaxial cable. The cable network 216 may include a head-end, or a central termination system that permits management of the cable connections to the users.

## 3. Providing Telephony Services

The third network telephony connection server 237 is preferably a SIP-based server that performs call initiation, maintenance, and teardown for the third data network telephone 228 connected to the cable network 216. The third network telephony connection server 240 may be similar or identical to the first and second network telephony connection servers 250 and 238 respectively connected to the first and second local area networks 212 and 214.

The system 200 shown in FIG. 2 includes a data network telephony system that permits the first and second data network telephones 208 and 218 respectively connected to the local area networks 212 and 214 to communicate with the third data network telephone 228 connected to the cable network 216. The system shown in FIG. 2 uses SIP in order to establish, maintain, and teardown telephone calls between users.

There are two major architectural elements to SIP: the user agent (UA) and the network server. The UA resides at the SIP end stations, (e.g. the data network telephones), and contains two parts: a user agent client (UAC), which is responsible for issuing SIP requests, and a user agent server (UAS), which responds to such requests. There are three different network server types: a redirect server, a proxy

server, and a registrar. The various network server types may be combined into a single server, such as the network telephony connection servers 250, 240, and 238. Not all server types are required to implement the embodiments of the present invention. The communication services to be provided will determine which servers  
5 are present in the communication system. Preferred embodiments of the present invention may be carried out using proxy servers.

One example of a SIP operation involves a SIP UAC issuing a request, a SIP proxy server acting as end-user location discovery agent, and a SIP UAS accepting the call. A successful SIP invitation consists of two requests: INVITE followed by  
10 ACK. The INVITE message contains a user identifier to identify the callee, a caller user identifier to identify the caller, and a session description that informs the called party what type of media the caller can accept and where it wishes the media data to be sent. User identifiers in SIP requests are known as SIP addresses. SIP addresses are referred to as SIP Uniform Resource Locators (SIP-URLs), which are of the form  
15 *sip:user@host.domain*. Other addressing conventions may also be used.

Redirect servers process an INVITE message by sending back the SIP-URL where the callee is reachable. Proxy servers perform application layer routing of the SIP requests and responses. A proxy server can either be stateful or stateless. A stateful proxy holds information about the call during the entire time the call is up,  
20 while a stateless proxy processes a message without saving information contained in the message. Furthermore, proxies can either be forking or non-forking. A forking proxy can, for example, ring several phones at once until somebody takes the call. Registrar servers are used to record the SIP address (called a SIP URL) and the associated IP address. The most common use of a registrar server is for the UAC to  
25 notify the registrar where a particular SIP URL can be reached for a specified amount of time. When an INVITE request arrives for the SIP URL used in a REGISTER message, the proxy or redirect server forwards the request correctly.

At the first local area network 212, the central registrar/proxy server, such as the first network telephony server 250, is the primary destination of all SIP messages  
30 trying to establish a connection with users on the first local area network 212. Preferably, the first network telephony server 250 is also the only destination advertised to the SIP clients outside the first local area network 212 on behalf of all the SIP clients residing on the first local area network 212. The network telephony server 250 relays all SIP INVITE messages to the appropriate final destination (or

another SIP proxy), based on a database lookup using a first SIP database (not shown) associated with the first network telephony server 250. This allows all mobile clients to register with their current locations.

Similarly, the second network telephony server 238 is the primary destination  
5 of all SIP messages trying to establish a connection with the data network telephone 218 connected to the second local area network 214. Preferably, the second network telephony server 238 is also the only destination advertised to the SIP clients outside the second local area network 214 on behalf of all the SIP clients (e.g. data network telephones) residing on the second local area network 214. The second network  
10 telephony server 238 relays all SIP INVITE messages to the appropriate final destination (or another SIP proxy), based on a database lookup using a second SIP database. The third network telephony server 237 behaves similarly to the first and second network telephony servers 250 and 238.

The data network telephones 208, 218, and 228 in the system 200 preferably  
15 have pre-programmed device identifiers (e.g. phone numbers), represented as SIP-URL's that are of the form *sip: user@domain*. An example is *sip: 8475551212@3Com.com*. After power-up, each of the data network telephones 208, 218, and 228 sends a SIP REGISTER message to the default registrar, such as the network telephony servers 250, 238, and 237. When a call arrives at one of the  
20 network telephony servers 250, 238, or 237 for any of the registered SIP URLs, the server will forward the call to the appropriate destination. If a data network telephone is moved to a new location, all calls to the associated SIP URL will still be properly routed to that device. In other words, the system in FIG. 2 provides device mobility in the sense that calls will "follow" the data network telephone according to its SIP  
25 URL. This is especially useful if the data network telephone 208, 218, or 228 is running the DHCP (Dynamic Host Configuration Protocol) so that when the location is changed, the IP address is also automatically changed.

An advantage of the system in FIG. 2 is that once the call is established between data network telephones, the data network 206 provides data connectivity for  
30 a plurality of data communications channels. For example, the data network telephones 208, 218, and 228 can communicate voice signals as voice-over-data packets on a voice-over-data channel. The data network telephones 208, 218, and 228 may also be able to communicate PID data as PID data packets on a PID data channel. Other data types may also be communicated. For example, the PID data may be

communicated to and from the PID 210 across link 209 to the data network telephone 208, where the PID data may be assembled into packets and disassembled from packets as part of the process for communicating the PID data packets across the data network 206 and any access networks, such as the first Ethernet LAN 212, the second  
5 Ethernet LAN 214, and the cable network 214. For example, the PID data may be communicated to and from at least one other PID (not shown) through a network device (such as a data network telephone) located in the system 200.

#### 4. The Data Network Telephones

The data network telephones 208, 218, and 228 are preferably telephones that  
10 include an Ethernet communications interface for connection to an Ethernet port. The Ethernet phones in FIG. 2 support the Internet Protocol (IP), using an IP address that is either statically configured or obtained by access to a Dynamic Host Configuration Protocol (DHCP) server.

FIG. 3 is a block diagram showing the first data network telephone 208  
15 connected to the local area network 212 in FIG. 2. The data network telephone 208 in FIG. 3 is connected to the network 212 by a network interface 270. The network interface 270 may, for example, be a network interface card, and may be in the form of an integrated circuit. A bus 248 may be used to connect the network interface 270 with a processor 240 and a memory 242. Also connected to the processor are user  
20 interface circuitry 260 and three alternative interfaces to a Personal Information Device (PID).

A first alternative interface 248 includes an RS-232 serial connection and associated coupling hardware and mechanisms. The first alternative interface 248 may, for example, be a docking cradle for a PID, such as a PDA (Personal Digital  
25 Assistant), in which information may be transferred between the PID and the first data network telephone 208. The second alternative interface comprises a first connection 254, such as an RS-232 connection, along with infrared circuitry 250 for converting signals into infrared output and for accepting infrared input. An infrared interface 252 may also be included within the second alternative interface. The third alternative  
30 interface comprises a first connection 256, such as an RS-232 connection, along with radio-frequency circuitry 258 for converting signals into radio frequency output and for accepting radio frequency input. A radio frequency interface 259 may also be included as part of the third alternative interface.

The three alternative interfaces described above are merely examples, and additional means for implementing the interface between the data network telephone 208 and the PID may also be used. Although three interfaces are shown in FIG. 3, there may be only one such interface in the data network telephone 208. More than  
5 one interface may be included to improve flexibility and to provide redundancy in case of failure of an interface.

The user interface circuitry 260 includes hardware and software components that access the functions of the handset, display, and keypad to provide user input and output resources for functions in the processor 240. The user interface circuitry may  
10 include a display interface 262, a keypad interface 264, an audio output interface 265, and an audio input interface 267.

The audio input interface 267 may receive voice signals from a microphone or other audio input device and convert the signals to digital information. The conversion preferably conforms to the G.711 *ITU Standard*. Further processing of the  
15 digital signal may be performed in the audio input interface 267, such as to provide compression (*e.g.* using G.723.1 standard) or to provide noise reduction, although such processing may also be performed in the processor 240. Alternatively, the audio input interface 267 may communicate an analog voice signal to the processor 240 for conversion to digital information.

The audio output interface 265 receives digital information representing voice  
20 from the processor 240 and converts the information to sound. In one embodiment, the audio output interface 265 receives information in the form of G.711 although other processing such as decompression may be performed in the audio output interface 265. Alternatively, the processor 240 may convert digital information to  
25 analog voice signals and communicate the analog voice signals to the audio output interface 265.

The keypad interface 264 and the display interface 262 include well-known device interfaces and respective signal processing techniques. The user interface circuitry 260 may support other hardware and software interfaces. For example, a  
30 videophone implementation might also include a camera and monitor. The data network telephones of the present invention are not limited to telephones or videophones – additional user interface types, for example, such as the ones needed for computer games, are also contemplated as being within the scope of the present invention.

The processor 240 may consist of one or more smaller processing units, including, for example, a programmable digital signal processing engine. In the preferred embodiment, the processor is implemented as a single ASIC (Application Specific Integrated Circuit) to improve speed and to economize space. The processor  
5 240 also may include an operating system, and application and communications software, firmware, or hardware, to implement the functions of the first data network telephone 208. For example, the processor may include a conferencing application 245 to assist in gathering communication partner data from a PID and to establish the conference call by connecting the conference call parties. The operating system may  
10 be any suitable commercially available embedded or disk-based operating system, or any proprietary operating system.

The processor 240 includes a media engine 241 and a signaling stack 243 to perform the primary communications and application functions of the data network telephone 208. The purpose of the signaling stack in an exemplary data network  
15 telephone 208 is to set up, manage, and tear down a call. During the setup phase, a user may use the keypad to enter a user identifier to call. The signaling stack 243 receives the user entry and formats a request message to send to the user identified by the user identifier to initiate a telephone call. When the request message is sent, the location of the user identified by the user identifier is discovered, communication  
20 parameters, such as the supported voice CODEC types are exchanged, and a voice over data channel is established. During the management phase, for example, other parties are invited to the call if needed. During the teardown phase, the call is terminated.

The signaling protocol used in the exemplary data network telephone 208 in  
25 FIG. 3 is the SIP protocol. In particular, the signaling stack implements a User Agent Client 244 and a User Agent Server 242, in accordance with the SIP protocol. Alternative signaling protocols, such as the ITU-T H.323 protocol and others, may also be used to implement the present invention.

Once the call is set up, the media engine 241 manages the communication over  
30 a data communications channel using a network transport protocol and the network interface 270. The media engine 241 sends and receives data packets having a data payload for carrying data and an indication of the type of data being transported. The media engine 241 in the data network telephone 208 may sample the voice signals from the audio input 267 (or receive voice samples from the audio input 267), encode

the samples, and build data packets on the sending side. On the receiver side, in addition to performing the reverse operations, the media engine also typically manages a receiver buffer to compensate for network jitter.

The media engine 241 includes hardware and software components for  
5 enabling conferencing 245, performing registration functions 247, voice-over-data functions 249, display data function 251, and keypad output functions 253. The media engine 241 processes data that is received from the first local area network 212, and data that is to be sent over the first local area network 212.

For data that is received from the first local area network 212, the media  
10 engine 241 may determine from the type of data in the packet whether packets contain sampled voice signals or data for performing other functions. Packets containing sampled voice signals are processed by voice over data function 249. The voice over data function 249 preferably conforms to a protocol for formatting voice signals as digital data streams. While any suitable protocol may be used, the media (voice  
15 signal) is preferably transported via the Real Time Protocol (RTP), which itself is carried inside of User Datagram Protocol (UDP). RTP is described in H. Schulzrinne et al., "RTP: A Transport Protocol for Real-Time Applications," IETF RFC 1889, Jan. 1996, which is incorporated herein by reference. UDP is described in J. Postel, "User Datagram Protocol," IETF RFC 768, Aug. 1980, and IP is described in J. Postel, ed.,  
20 "Internet Protocol," IETF RFC 791, Sept. 1981, both of which are incorporated by reference herein.

Packets containing data for use in registering the data network telephone 208 with a network telephony server are processed by the registration function 247. By registering the data network telephone 208, a user may establish with the network  
25 telephony service provider that calls addressed to the user's user identifier may be connected to the data network telephone 208. Registration may occur when the data network telephone 208 sends a request to register to a service provider host. The service provider host may respond by setting the user's user identifier to correspond to the telephone identifier of the data network telephone 208, and by acknowledging  
30 the request with a status message to the data network telephone 208. In one embodiment, a request to register the data network telephone 208 to a default user is automatically sent during power-up of the data network telephone 208.

Other features may be added to the registration functions 247, or implemented as extensions to the registration functions 247. For example, the data network



telephone 208 may be provisioned to provide selected network telephony services by establishing a data connection with a service provider, requesting the selected services, and receiving data that ensures that the services have been successfully provisioned. Such services may include, for example, caller identification, call forwarding, voice mail and any other service offered by the network telephony service provider to enhance the capabilities of the data network telephone 208. One advantage of such provisioning functions is that services may be ordered for temporary use in a manner that is convenient to the user.

Packets containing data for display on the display device are processed by the display data function 251. The display data function 251 may be used for displaying, for example, the name(s) and user identifier(s) of the other party(-ies) to the call, the status of the telephone call, billing information, and other information

For data that is to be sent over the data network 212, the media engine 241 formats the data as data packets in accordance with a selected protocol. The selected protocol is preferably the protocol that is supported by the data network telephone that will receive the data for the particular type of data being transported.

The voice-over-data function 249 formats voice samples according to the protocol used by the receiving data network telephone. In one preferred embodiment, the voice over data function 249 formats voice samples as RTP packets. The registration function 247 and the keypad output function 253 may control the transport of data that does not represent voice signals.

The data network telephones 218 and 228 are preferably similar or identical to the data network telephone 208.

#### 5. The Portable Information Device (PID)

FIG. 4 is a block diagram showing the PID 210 in communication with the data network telephone 208 having a connection to the first LAN 212. The PID 210 is linked to the data network telephone 208 by a point-to-point interface 545. A bus 580 may be used to connect the point-to-point interface 545 with a processor 540, a memory 542, data storage 543, and user interface circuitry 544.

The point-to-point interface 545 shown in FIG. 4 illustrates three alternative interfaces to a data network telephone.

A first alternative interface 546 includes a RS-232 serial connection and associated coupling hardware mechanisms. The first alternative interface 546 may,

for example, be a docking cradle for a PID, in which information can be transferred between the PID 210 and the first data network telephone 208. The second alternative interface comprises a first connection 548, such as a RS-232 serial connection, along with infrared circuitry 250 for converting signals into infrared output and for  
5 accepting infrared input. An infrared interface 552 may also be included within the second alternative interface. The third alternative interface comprises a first connection 554, such as an RS-232 connection, along with radio-frequency circuitry 556 for converting signals into radio frequency output and for accepting radio frequency input. A radio frequency interface 558 may also be included as part of the  
10 third alternative interface.

The three alternative interfaces described above are merely examples, and additional means for implementing the interface between the PID 210 and the data network telephone 208 may also be used. Although three interfaces are shown in FIG. 4, there may be only one such interface in the PID 210. More than one interface  
15 may be included to improve flexibility and to provide redundancy in case of failure of an interface.

The user interface circuitry 544 includes hardware and software components that provide user input and output resources for functions in the processor 540. The user interface circuitry preferably includes a display output 562, a display input 565,  
20 and an additional input/output interface 567.

The display output 562 preferably receives digital information representing graphical or other data from the processor 540 and converts the information to a graphical display, such as text and/or images.

The display input 565 may receive PID data inputs from a user of the PID 210.  
25 The PID data inputs are preferably entered by the user with a stylus on a pressure-sensitive display screen. Similarly, the display output 562 preferably displays the PID data on the display screen.

The additional input/output interface 567 allows the user to enter other types of data besides PID data into the PID 210. For example, audio data, additional PID  
30 data, or additional input may be entered through the additional input/output interface 567. Touch-sensitive screen buttons are an exemplary mechanism for a user to enter control data into the PID 210.

The processor 540 includes an operating system and application and communication software, firmware, or hardware to implement the functions of the

PID 210. The operating system may be any suitable commercially available operating system, or any proprietary operating system. The operating system and software may be stored on data storage 543. The conference application 575 preferably allows a user to select communication partners to be invited to a conference call initiated by the user of the PID 210. The conference application also should cause user identification information for the communication partners to be transmitted from the PID 210 to the first data network telephone 208 via the link 209. Although the processor 540 is shown connected to the data storage 543 through a bus 580, other configurations may also be used. Similarly, the memory 542 may be alternatively configured, and may be embedded within the processor 540.

The PID 210 is able to send data to and receive data from the data network telephone 208 across a point-to-point link, such as the point-to-point link 209 shown in FIG. 2. A user enters PID data at the display input 565. The PID data may be processed in the user interface circuitry 544 or it may go directly to the processor 540 or the memory 542. The processor 540 may also perform processing functions, such as compression. A PID data application may be used to implement the display input, the display output, and the processing functions. For example, a drawing application may be used to accept PID data input, the display input 565 from a user drawing with a stylus on the display screen of a PDA. A drawing application could then display the drawing through the display output 562 to enable the user to see a visual representation of the drawing. If the user desires to share the drawing with a second user on the system 200, where the second user is using a second PID, the PID data from the drawing application can be transmitted through one of the point-to-point interfaces 545, allowing the data to be received by the data network telephone 208. An application in the data network telephone 208 receives the PID data across the point-to-point link, and the PID data is prepared for transmission across the data network 206, such as by the media engine 241 shown in FIG. 3. Preferably the PID data is converted to PID data packets and is communicated on a PID data channel across the first LAN 212 through the router 213 across the data network 206 and eventually to a network device at which the second PID is located.

The point-to-point link 209 may be implemented as a serial bit stream between an application in the PID 210 and an application in the first data network telephone 208. For example, the link 209 could be an infrared link that is implemented with minimal stack interpretation. However, the infrared link 209 between PID 210 and

the first data network telephone 208 can alternatively be implemented using all or parts of a specialized protocol, such as the Infrared Data Association (IrDA) protocol stack, where data is interpreted through the stack between application-layer processes at each end of the link.

5           FIG. 5 is a protocol diagram illustrating the layers of the IrDA protocol stack. An IrDA stack is implemented at each of the connection endpoints of an IrDA link. The required layers of an IrDA protocol stack are the physical layer 602, the IrLAP layer 604, the IRLMP layer 606 and the IAS layer 608. The physical layer 602 specifies optical characteristics of the link, encoding of data, and framing for various  
10 speeds. The IrLAP (Link Access Protocol) layer 604 establishes the basic reliable connection between the two ends of the link. The IRLMP (Link Management Protocol) layer 606 multiplexes services and applications on the IrLAP connection. The IAS (Information Access Service) layer 608 provides a directory or "yellow pages" of services on an IrDA device.

15           The IrDA protocol also specifies a number of optional protocol layers, these protocol layers being TinyTP 610, IrOBEX 612, IrCOMM 614 and IrLAN 616. TinyTP (Tiny Transport Protocol) 610 adds per-channel flow control to keep traffic over the IrDA link moving smoothly. This important function is required in many cases. IrOBEX (Infrared Object Exchange protocol) 612 provides for the easy  
20 transfer of files and other data objects between the IrDA devices at each end of the link. IrCOMM 614 is a serial and parallel port emulation that enables existing applications that use serial and parallel communications to use IrDA without change. IrLAN (Infrared Local Area Network) 616 enables walk-up infrared LAN access for laptops and other devices. The use of the optional layers depends upon the particular  
25 application in the IrDA device. The IrDA protocol stack is defined by such standards documents as "IrDA Serial Infrared Physical Layer Link Specification", "IrDA 'IrCOMM': Serial and Parallel Port Emulation over IR (Wire Replacement)", "IrDA Serial Infrared Link Access Protocol (IrLAP)", "IrDA Infrared Link Management Protocol (IrLMP)", and "IrDA 'Tiny TP': A Flow-Control Mechanism for use with  
30 IrLMP", and related specifications published by the IrDA and available at <http://www.irda.org/standards/specifications.asp> and is incorporated by reference herein.

In one embodiment, the data network telephones 208, 218, and 228 merely provide a data tunnel for the data channel attendant to the infrared links, while the

IrDA protocol stack is implemented at endpoint PID devices, such as PID 210. Alternatively, IrDA stacks can be implemented in the data network telephones as well. By implementing additional layers of the IrDA protocol stack, the PID applications and the base applications in the data network telephones can be  
5 simplified because the IrDA protocol layers take over certain functions. For example, the IrDA protocol stack can be implemented at each PID used in a conference call, and the IrOBEX layer 612 can be used to transfer text and graphics object files, such as drawings or electronic business cards, end-to-end between PID devices connected via data network telephones and networks.

10

#### 6. Providing Telephony and Conferencing Services

FIG. 6 is a functional block diagram and protocol stack diagram illustrating an embodiment of the protocol stacks in the PID 210 and the first data network telephone 208 that support link 209. In the infrared RS-232 embodiment, the point-to-point  
15 interface circuitry 545 in the PID 210 provides the physical layer 656, such as that specified by the Infrared Data Association (IrDA), that connects via link 209 to the point-to-point interface circuitry 260 implementing a physical layer 664 in the first data network telephone 208. The data link layer 654 in PID 210 provides data link control for link 209 in transferring data to and from a PID application client 652.  
20 Similarly, the first data network telephone 208 includes a data link layer 662 and a base application server 600 that is configured to synchronize connection and other functions with the PID application 652 in PID 210.

When PID 210 is activated, either through power-up or through a user input at the user interface 650, the synchronization application client 652 in the PID 210 may  
25 send the user's SIP URL across the link 209 to the first data network telephone 208, where it is received by the synchronization application server 600. The synchronization application server 600 sends the SIP URL received from the PID 210 across connection 230 and the Ethernet LAN 212 through connection 243 to the network telephony connection server 250. The network telephony connection server  
30 250 may store the SIP URL and the IP address of the associated data network telephone 208 in a SIP database (not shown) so that the SIP URL is listed as being resident at the IP address of the data network telephone 208. (If the network telephony connection server 250 uses a location server for registration/location tasks,

the registration information might instead be stored with such a location server). SQL (Structured Query Language) is preferred for implementing and maintaining the database. Once the PID 210 is registered with the network telephony connection server 250, calls to the SIP URL for PID 210 (or the user of the PID 210) will be  
5 directed to the first data network telephone 208.

FIG. 7 is a functional block and protocol stack diagram illustrating an embodiment of the present invention where a SIP connection is established from the first data network phone 208 to the second data network phone 218 through network connection 230, first access network 212, data network 206, second access network  
10 214 and network connection 219. The routers 213 and 215 and associated connections are not shown to simplify the block diagram representation. Although only two data network telephones are shown in FIG. 7, a three-party conference call would be very similar to what is shown in FIG. 7.

The diagram of FIG. 7 shows how PID data can be communicated from one  
15 PID to another PID during a conference call in one aspect of the present invention. The PID application 652 in PID 210 is configured to send PID data input through the user interface 650 through link 209 to base application 660 in the first data network phone 208. In this embodiment, base application 660 is configured to define data channels for transport to the second data network telephone 218.

Multiple data channels in SIP may be defined through the Session Description  
20 Protocol described in RFC 2327, herein incorporated by reference. Included in a SIP INVITE request for a connection are options for the requested connection that describe the number and type of media streams. Each media stream is described by a "m=" line in the INVITE request. For example, a request for a connection that  
25 includes an audio stream and a bidirectional video stream using H.261 might look like this:

```
v=0  
o=alice 2890844526 2890844526 IN IP4 host.anywhere.com  
30 c=IN IP4 host.anywhere.com  
m=audio 49170 RTP/AVP 0  
a=rtpmap:0 PCMU/8000  
m=video 51372 RTP/AVP 31  
a=rtpmap:31 H261/90000
```

TABLE 1.

If the called device includes functionality to receive the connection as described in Table 1, then the called device will respond to the INVITE request with a  
5 200 OK response that includes the same option values. If the called device or party is unable or unwilling to receive such a connection, then it will respond with alternative option values for the connection. See RFC 2543 for further details regarding the negotiation of connection parameters in SIP.

In FIG. 7, a first data channel for voice data and a second data channel for PID  
10 data have been negotiated by the base applications 660 in the first data network telephone 208 and the base application 674 in the second data network telephone 218. The base applications 660 and 674 transfer voice data between the AUDIO applications, such as applications including G.711 encoders, in each phone via the first data channel. The base application 660 in phone 208 is also configured to send  
15 the PID data received via link 209 from PID 210 to the base application 674 in phone 218 via the second data channel. The base application in phone 218 is configured to forward the PID data received via the second data channel to a second PID 220 via a second link 221. The PID application 688 in PID 220 then outputs the PID data received from phone 218 to the user interface 686 for output to the user of PID 220.

20 The PID data in FIG. 5 can take a variety of forms. For example, the PID data can be a text file containing information about the user of PID 210, such as an electronic business card. The PID data can also be drawing data generated by graphical applications in the PIDs 210 and 220 whereby a user drawing on a touchscreen of the user interface 650 in PID 210 generates corresponding PID data  
25 that is transmitted via the second data channel to PID 220a for display on the user interface 686 of PID 220a. The media description for the media stream can be defined during connection setup to establish a connection appropriate to the type of data being transferred. These examples represent just a few of the applications for this aspect of the present invention and should not be viewed as limiting the present  
30 invention.

In one embodiment, RTP data packets for two or more types of data are exchanged between the first data network telephone 208 and the second data network telephone 218a according to one of three possible methods. In the first method, one RTP data channel (or RTP stream) on UDP carries data packets in which both data

types are present in single split packets. Each such split packet contains (1) a source port number and a destination port number in the UDP portion, and (2) a special payload sequentially including each of the data types in the RTP portion. The special payload type can be defined in the SDP described with reference to FIG. 6. Other information is also contained in each packet as well. In the second method for transmitting two or more data types, a separate RTP over UDP data channel is created for each of the different data types, and the RTP header indicates which type of data is contained in each packet. For example, voice data coded as G.711 might be assigned a payload type code of 0, while PID data is assigned a payload type code of 190. In the third method for transmitting two or more data types, a single RTP/UDP data channel (RTP/UDP stream) is created that contains data packets of two or more different types. In this method, the data types are identified in a payload type field in the RTP header of each packet, enabling an underlying application to identify which data packets are voice data packets and which data packets are PID data packets, for example.

FIG. 8A is a block and message flow diagram showing a system 300 for using a PID 210 to establish a conference call on a telephony network, according to a first embodiment of the present invention. A single internetwork 700 represents the combination of any access networks at which data network telephones 208, 218, and 228 reside, any data networks connecting any existing access networks, and any routers, bridges, or other similar devices. For purposes of illustration, it will be assumed that UserA is associated with the PID 210 and is located at (registered with) the first data network telephone 208. UserB is located at (registered with) the second data network telephone 218. UserC is located at (registered with) the third data network telephone 228.

UserA initiates a conference call to Users B and C by causing the PID 210 to transmit user identifiers (such as SIP URLs) of the desired communication partners (such as UserB and UserC) to the first data network telephone 208. For example, UserA can select the names or user identifiers of UserB and UserC in an address book application located on the PID 210. A call application on the PID 210 may then be used to transmit the user identifiers across the link 209 to the first data network telephone 208.

The first data network telephone 208 performs call-management procedures to initiate the call to the desired communication partners. If SIP is utilized as the call-



management protocol, then the first data network telephone transmits INVITE requests to the network elements (such as data network telephones) at which the communication partners are located (or registered). If the first data network telephone does not know where the communication partners are registered, the first data  
5 network telephone will likely utilize at least one network telephony connection server (not shown in FIG. 8A) to locate the communication partners and transmit appropriate INVITE requests. When the communication partners (UserB and UserC) receive the INVITE requests at the second and third data network telephones 218 and 228, they may either accept or reject the requests. Assume that UserB and UserC both accept  
10 the INVITE requests by transmitting a 200 OK message according to SIP. After any necessary acknowledgement messages are transmitted by the first data network telephone to the second and third data network telephones 218 and 228, data channels may be created (1) between the first data network telephone 208 and the second data network telephone 218, and (2) between the first data network telephone 208 and the  
15 third data network telephone 228. Note that there need not be a data channel created between the second data network telephone 218 and the third data network telephone 228. This is because the first data network telephone 208 had data channels to all other communication partners, and is therefore able to mix all incoming data channel streams so that UserB is able to receive UserC's communications and vice-versa.

20 The system 300 in FIG. 8A has the advantage of being relatively simple to set up, but may not scale as well as other systems as more users are added to the conference call. This is due to the fact that mixing for all the parties is occurring at the first data network telephone 208. It is however possible for additional communication partners to be invited by data network telephones other than the first  
25 data network telephone 208, in which case some of the mixing may occur at other data network telephones as well.

FIG. 8B is a message flow diagram showing an exemplary flow of messages in a system 300 for using a PID 210 to establish a conference call on a telephony network, according to a first embodiment of the present invention. A PID 210  
30 associated with a UserA transmits a request 402 to a first data network telephone 208 to call UserB at UserB\_id and UserC at UserC\_id. UserB\_id and UserC\_id may be SIP URLs, for example. The first data network telephone 208 may acknowledge the request to call UserB and UserC by sending an acknowledgement message 404. The first data network telephone 208 then may attempt to connect UserB by sending a first

INVITE message 470, preferably containing UserA session information in SDP (Session Description Protocol) format, to a second data network telephone 218 associated with UserB. A network telephony access server, such as the second network telephony access server 238 may be accessed to locate the second data network telephone as being registered with UserB. Similarly, the first data network telephone 208 then may attempt to connect UserC by sending a second INVITE message 472, preferably containing UserA session information in SDP format, to a third data network telephone 228 associated with UserC. A network telephony access server, such as the third network telephony access server 237 may be accessed to locate the third data network telephone as being registered with UserC. The second and third data network telephones 218 and 228 then may respond by sending separate 200 OK messages 478 and 480 if SIP is being used as the call-management protocol. The first data network telephone 208 may acknowledge the responses 478 and 480 by transmitting ACK messages 482 and 484 to the second and third data network telephones 218 and 228.

After the call has been initiated according to the procedure described above, communications can be transmitted over data channels created by the data network telephones 208, 218, and 228. A first data channel 486 is created between the first data network telephone 208 and the second data network telephone 218. A second data channel 488 is created between the first data network telephone 208 and the third data network telephone 228. Additional data channels may also be created to communicate information between the data network telephones. For example, a third data channel may be created between the first data network telephone 208 and the second data network telephone 218 to allow PID data, such as graphical display data, to be communicated between the first and second data network telephones 208 and 218. If UserA decides to terminate the call, UserA can cause the first data network telephone 208 to transmit a first BYE message 490 to the second data network telephone 218 and a second BYE message 492 to the third data network telephone 228. The second and third data network telephones 218 and 228 may respond by sending 200 OK messages 494 and 496 to the first data network telephone 208. Variations of the messages described above can also be used, such as if a call-management protocol other than SIP is used.

FIG. 9A is a block and message flow diagram showing a system 400 for using a PID 210 to establish a conference call on a telephony network, according to a

second embodiment of the present invention. A single internetwork 700 again represents the combination of any access networks at which data network telephones 208, 218, and 228 reside, any data networks connecting any existing access networks, and any routers, bridges, or other similar devices. For purposes of illustration, it will  
5 be assumed that UserA is associated with the PID 210 and is located at (registered with) the first data network telephone 208. UserB is located at (registered with) the second data network telephone 218. UserC is located at (registered with) the third data network telephone 228.

UserA initiates a conference call to Users B and C by causing the PID 210 to  
10 transmit user identifiers (such as SIP URLs) of the desired communication partners (such as UserB and UserC) to the first data network telephone 208. For example, UserA can select the names or user identifiers of UserB and UserC in an address book application located on the PID 210. A call application on the PID 210 may then be used to transmit the user identifiers across the link 209 to the first data network  
15 telephone 208.

The first data network telephone 208 performs call-management procedures to initiate the call to the desired communication partners. If SIP is utilized as the call-management protocol, then the first data network telephone transmits INVITE requests to the network elements (such as data network telephones) at which the  
20 communication partners are located (or registered). If the first data network telephone does not know where the communication partners are registered, the first data network telephone will likely utilize at least one network telephony connection server (not shown in FIG. 9A) to locate the communication partners and transmit appropriate INVITE requests.

In the example shown in FIG. 9A, the first data network telephone 208 has instructed the second data network telephone 218 to transmit an INVITE request to the third data network telephone 228. If SIP, with the call control draft extension (H. Schulzrinne et al., draft-ietf-mmusic-sip-cc-01.txt, Internet Engineering Task Force), is being used as the call-management protocol, this instruction can be specified in an  
30 "also" header of the SIP INVITE message. When the second data network telephone 218 receives such an INVITE message with the "also" header indicating that the second data network telephone 218 should invite the third data network telephone 228, the second data network telephone should send an INVITE request to the third

data network telephone 228 with an indication in the INVITE request that the INVITE request was transmitted at the direction of the first data network telephone 208.

When the communication partners (UserB and UserC) receive the INVITE requests at the second and third data network telephones 218 and 228, they may either  
5 accept or reject the requests. Assume that UserB and UserC both accept the INVITE requests by transmitting a 200 OK message according to SIP. After any necessary acknowledgement messages are transmitted by the first data network telephone to the second and third data network telephones 218 and 228, and by the second data network telephone 218 to the third data network telephone 228, data channels may be  
10 created (1) between the first data network telephone 208 and the second data network telephone 218, (2) between the first data network telephone 208 and the third data network telephone, and (3) between the second data network telephone 218 and the third data network telephone 228. Note that in this embodiment, a data channel is created between the second data network telephone 218 and the third data network  
15 telephone 228. Therefore, the first data network phone 208 need not provide mixing services for UserB and UserC to be able to communicate with each other.

FIG. 9B is a message flow diagram showing an exemplary flow of messages in a system 400 for using a PID 210 to establish a conference call on a telephony network, according to a second embodiment of the present invention. A PID 210  
20 associated with the UserA transmits a request 502 to a first data network telephone 208 to call UserB at UserB\_id and UserC at UserC\_id. UserB\_id and UserC\_id may be SIP URLs, for example. The first data network telephone 208 may acknowledge the request to call UserB and UserC by sending an acknowledgement message 504. The first data network telephone 208 may attempt to connect UserB by sending a first  
25 INVITE message 506, preferably containing UserA session information in SDP (Session Description Protocol) format, to the second data network telephone 218 associated with UserB. In this embodiment, the INVITE request message 506 is a SIP INVITE request message that includes the call control draft extension (H. Schulzrinne et al., draft-ietf-mmusic-sip-cc-01.txt, Internet Engineering Task Force), to allow the  
30 first data network telephone 208 to instruct the second data network telephone 218 to send an INVITE request to the third data network telephone 228 by using an "also" header in the SIP INVITE message 506. A network telephony access server, such as the second network telephony access server 238 may be accessed to locate the second data network telephone as being registered with UserB. Similarly, the first data

network telephone 208 then may attempt to connect UserC by sending a second INVITE message 508, preferably containing UserA session information in SDP format, to a third data network telephone 228 associated with UserC. A network telephony access server, such as the third network telephony access server 237 may be  
5 accessed to locate the third data network telephone as being registered with UserC. The second and third data network telephones 218 and 228 then may respond by sending separate 200 OK messages 510 and 512 if SIP is being used as the call-management protocol. The first data network telephone 208 may acknowledge the responses 510 and 512 by transmitting ACK messages 514 and 516 to the second and  
10 third data network telephones 218 and 228.

After the call has been initiated according to the procedure described above, communications can be transmitted over data channels created by the data network telephones 208, 218, and 228. A first data channel 518 is created between the first data network telephone 208 and the second data network telephone 218. A second  
15 data channel 522 is created between the first data network telephone 208 and the third data network telephone 228. A third data channel 524 is created between the second data network telephone 218 and the third data network telephone 228. Additional data channels may also be created to communicate information between the data network telephones. Voice data as well as other data types may be communicated  
20 across the data channels. If UserA decides to terminate the call, UserA can cause the first data network telephone 208 to transmit a first BYE message 526 to the second data network telephone 218 and a second BYE message 528 to the third data network telephone 228. The second and third data network telephones 218 and 228 may respond by sending 200 OK messages 530 and 532 to the first data network telephone  
25 208. Variations of the messages described above can also be used, such as if a call-management protocol other than SIP is used.

FIG. 10A is a block and message flow diagram showing a system 500 for using a PID 210 to establish a conference call on a telephony network, according to a third embodiment of the present invention. A single internetwork 700 represents the  
30 combination of any access networks at which data network telephones 208, 218, and 228 reside, any data networks connecting any existing access networks, and any routers, bridges, or other similar devices. A conference server 710 is shown connected to the internetwork 700, but may be connected to any data network or access network within the internetwork 700, including an access network other than

one to which the data network telephones 208, 218, and 228 are connected. For purposes of illustration, it will be assumed that UserA is associated with the PID 210 and is located at (registered with) the first data network telephone 208. UserB is located at (registered with) the second data network telephone 218. UserC is located at (registered with) the third data network telephone 228.

UserA initiates a conference call to Users B and C by causing the PID 210 to transmit user identifiers (such as SIP URLs) of the desired communication partners (such as UserB and UserC) to the first data network telephone 208. For example, UserA can select the names or user identifiers of UserB and UserC in an address book application located on the PID 210. A call application on the PID 210 may then be used to transmit the user identifiers across the link 209 to the first data network telephone 208.

The first data network telephone 208 performs call-management procedures to initiate conference call. If SIP is utilized as the call-management protocol, then the first data network telephone 208 transmits an INVITE request to the conference server 710. In the example shown in FIG. 10A, the INVITE request instructs the conference server 710 to transmit INVITE requests to the second and third data network telephones 218 and 228. If SIP, with the call control draft extension (H. Schulzrinne et al., draft-ietf-mmusic-sip-cc-01.txt, Internet Engineering Task Force), is being used as the call-management protocol, the first data network telephone 208 can specify this instruction in an "also" header of the SIP INVITE message. When the conference server 710 receives such an INVITE message with the "also" header indicating that the conference server 710 should invite the second and third data network telephones 218 and 228, the conference server 710 should send INVITE requests to the second and third data network telephones 218 and 228 with an indication in the INVITE request that the INVITE request was transmitted at the direction of the first data network telephone 208.

When the communication partners (UserB and UserC) receive the INVITE requests at the second and third data network telephones 218 and 228, they may either accept or reject the requests. Assume that UserB and UserC both accept the INVITE requests by transmitting a 200 OK message according to SIP. After any necessary acknowledgement messages are transmitted by the second and third data network telephones 218 and 228 to the conference server 710, data channels may be created (1) between the first data network telephone 208 and the conference server 710, (2)

between the second data network telephone 218 and the conference server 710, and (3) between the third data network telephone 228 and the second data network telephone 218. Note that in this embodiment, no data channel needs to be created between any of the first, second, or third data network telephones 208, 218, and 228.

5 This is because the conference server has data channels to all of the data network telephones participating in the conference call, and is therefore able to mix all incoming data channel streams so that each of the data network telephones 208, 218, and 228 is able to communicate with every other data network telephone.

FIG. 10B is a message flow diagram showing an exemplary flow of messages in a system 400 for using a PID 210 to establish a conference call on a telephony network, according to a third embodiment of the present invention. A PID 210 associated with the UserA transmits a request 834 to a first data network telephone 208 to set up a conference call that includes UserB at UserB\_id and UserC at UserC\_id. UserB\_id and UserC\_id may be SIP URLs, for example. The first data network telephone 208 may acknowledge the request to call UserB and UserC by sending an acknowledgement message 836. The first data network telephone 208 sends an INVITE message 838 to a conference server 710. The INVITE message 838 is preferably a SIP INVITE request message that includes the call control draft extension (H. Schulzrinne et al., draft-ietf-mmusic-sip-cc-01.txt, Internet Engineering Task Force), to allow the first data network telephone 208 to instruct the conference server 710 to send INVITE requests to the second and third data network telephones 218 and 228 by using an “also” header in the SIP INVITE message 838. The conference server 710 responds with a 200 OK message 840, and the first data network telephone 208 sends an acknowledgment message 843. The conference server 710 proceeds to transmit INVITE messages 842 and 844 to the second and third data network telephones 218 and 228. The second and third data network telephones 218 and 228 respond with 200 OK messages 846 and 848 to the conference server 710 that include SDP (Session Description Protocol) information corresponding to the second and third data network telephones 218 and 228. Network telephony access servers, such as the second network telephony access servers 250, 238, and 237 may be accessed to locate the data network telephones 218 and 228, and the conference server 710. The conference server 710 acknowledges the responses of the second and third data network telephones 218 and 228 with ACK messages 850 and 852.

After the conference call has been set up according to the procedure described above, communications can be transmitted over data channels created by the data network telephones 208, 218, and 228, and the conference server 710. A first data channel 854 is created between the first data network telephone 208 and the  
5 conference server 710. A second data channel 856 is created between the second data network telephone 218 and the conference server 710. A third data channel 858 is created between the third data network telephone 228 and the conference server 710. Additional data channels may also be created to communicate information between the data network telephones. Voice data as well as other data types may be  
10 communicated across the data channels. Mixing is controlled by a mixer in the conference server 710 so that all parties to the conference call hear all communications, if desired. If UserA decides to terminate the call, UserA can cause the first data network telephone 208 to transmit a BYE message 860 to the conference server 710. The conference server 710 may respond by sending a 200 OK messages  
15 862 to the first data network telephone 208. Variations of the messages described above can also be used, such as if a call-management protocol other than SIP is used.

FIG. 11 is a pictorial diagram showing an exemplary display screen 902 of a PID 210 displaying entries from an address book application 926 according to one embodiment of the present invention. Shown are a first contact entry 928 and a  
20 second contact entry 932. The entries each contain contact information, such as name, address, email, SIP URL, and other information. In the preferred embodiment, the user of the PID 210 is given the option to flag entries in the address book, such as by checking a flag field 930 in the contact entry 928. When the communication parties to the impending conference call have been flagged (UserB 928 and UserC  
25 932 in FIG. 11), the user of the PID 210 can click on a box 902 to cause a conference call to be placed to people, numbers, or locations referred to by the flagged contact entries.

FIG. 12 is a pictorial diagram showing an exemplary display screen 902 of a PID 210 displaying a conference call attempt 948 according to one embodiment of the  
30 present invention. Such a screen 902 may be part of a conference call application 946 executed after contact entries are flagged in the example of FIG. 11 to initiate a conference call. The conference call application 946 is shown attempting a conference call to two communication partners: UserB 950 and UserC 952. Note that a timeout period may be set to end a call attempt to a communication partner that does



not respond. Other methods for handling unanswered requests may also be implemented, and are intended to be within the scope of the present invention.

While the invention has been described in conjunction with presently preferred embodiments of the invention, persons of skill in the art will appreciate that variations  
5 may be made without departure from the scope and spirit of the invention. For example, the access networks shown in FIG. 2 may comprise any other suitable type of local area network or service infrastructure.

In addition, protocols of various types are referenced throughout. While preferred and alternative embodiments may implement selected protocols, any  
10 suitable replacement protocol not mentioned, or any function not part of a protocol used to replace a corresponding function from a protocol may be implemented without departing from the scope of the invention.

This true scope and spirit is defined by the appended claims, interpreted in light of the foregoing.

**WE CLAIM:**

1. A system for establishing a conference call on a data network telephony system including a network to providing data connectivity for a plurality of data communications channels using data transport protocols, the system comprising in combination:
  - 5 a plurality of data network telephones connected to the network, each data network telephone operable to communicate a voice signal as voice-over-data packets on a voice-over-data channel, the voice-over-data channel being one of the plurality of data communications channels on the network, the data network telephones each operable to convert voice-over-data packets communicated on the voice-over-data
  - 10 channel to voice signals; and
  - a portable information device comprising a user interface and a data network telephone interface, the user interface operable to accept communication partner data from a user, the first data network telephone interface operable to communicate the communication partner data to a first data network telephone to enable the first data
  - 15 network telephone to invite at least one communication partner to a conference call, the at least one communication partner specified in the communication partner data.
2. The system of Claim 1 wherein the user communicates voice data on the voice-over-data channel with the at least one communication partner.
3. The system of Claim 1 wherein each data network telephone includes a device identifier.
4. The system of Claim 3 wherein the device identifier includes an Internet Protocol (IP) address.
5. The system of Claim 3 wherein the communication partner data includes at least one Session Initiation Protocol (SIP) address.
6. The system of Claim 3 wherein the communication partner data includes at least one E.164 telephone number.

7. The system of Claim 1 further comprising:  
at least one database accessible through the network to store a plurality of device identifiers and a plurality of user identifiers associated with the plurality of device identifiers; and
- 5 at least one network telephony connection server operable to access the at least one database to initiate the voice-over-data channel in response to the first data network telephone inviting the at least one communication partner.
8. The system of Claim 1, wherein the conference call is set up in accordance with the Session Initiation Protocol (SIP).
9. The system of Claim 1, wherein the conference call is set up in accordance with the H.323 Protocol.
10. The system of Claim 1 wherein the conference call is set up in accordance with the MEGACO protocol.
11. The system of Claim 1 wherein the conference call is set up in accordance with the MGCP protocol.
12. The system of Claim 7 wherein the first data network telephone sends an invite message to invite the at least one communication partner, wherein the invite message includes a communication partner user identifier, wherein the request message includes a callee user identifier, and wherein the network telephony connection server accesses the
- 5 database to determine a communication partner device identifier corresponding to the communication partner user identifier.
13. The system of Claim 2 wherein the user communicates PID data on a PID data channel with the at least one communication partner, the PID data channel being one of the plurality of data communication channels on the data network.
14. The system of Claim 1, further comprising a conference server linked to the network, wherein the first data network telephone invites the at least one communication partner to the conference call by inviting the conference server, and wherein the

conference server invites each at least one communication partner at corresponding data  
5 network telephones.

15. A method for enabling a user to initiate a conference call with a portable information device, comprising in combination:  
accepting from the user at the portable information device at least one contact entry selection corresponding to at least one communication partner, wherein each of the at  
5 least one contact entry selections includes a user identifier;  
and  
transmitting the at least one user identifier to a data network telephone linked to a data network, wherein the data network telephone establishes the conference call by inviting the at least one communication partner to the conference call, whereby the user may use  
10 the data network telephone to communicate voice data with the at least one communication partner via the data network.

16. A computer-readable medium containing instructions for causing a processing unit to perform the method of Claim 15.

17. The method of Claim 15, wherein the data network telephone invites the at least one communication partner by transmitting at least one invite message to a registration server, wherein the at least one invite message includes the user identifier, wherein the registration server accesses a registration database to determine a device identifier  
5 registered to the user identifier, and wherein the device identifier corresponds to a communication partner data network telephone linked to the data network.

18. The method of Claim 15, wherein the portable information device is a personal digital assistant (PDA).

19. The method of Claim 15, wherein the portable information device is a wireless phone.

5 20. The method of Claim 15, wherein the data network is a public internet.

21. The method of Claim 15, wherein the conference call is established according to the Session Initiation Protocol (SIP).
22. The method of Claim 15, wherein the conference call is established according to the H.323 protocol.
23. The method of Claim 15, wherein the conference call is established according to the MGCP protocol.
24. The method of Claim 15, wherein the conference call is established according to the MEGACO protocol.
25. The method of Claim 15, wherein the user makes the at least one contact entry selection using an address book application located on the portable information device.
26. The method of Claim 15, further comprising:  
accepting PID data from the user at the portable information device; and transmitting the PID data to the data network telephone, wherein the data network  
5 telephone communicates the PID data to at least one communication partner data network  
telephone to enable at least one of the communication partners to receive the PID data at a communication partner portable information device.
27. The method of Claim 15, wherein the PID data is non-voice data that is communicated concurrently with the voice data.
28. The method of Claim 16, wherein at least two communication partners are invited, and wherein the data network telephone mixes the voice data to enable each communication partner to communicate voice data with each other communication partner and the user.  
5
29. The method of Claim 15, wherein at least two communication partners are invited, wherein each of the communication partners is associated with a communication partner data network telephone, and wherein at least one of the communication partners invites

another communication partner to enable each communication partner to communicate  
5 voice data with each other communication partner and the user.

30. The method of Claim 15, wherein the data network telephone invites the at least one communication partner to the conference call by inviting a conference server, and wherein the conference server invites each of at least one communication partner data network telephones corresponding to each of the at least one communication partner.

31. A data network telephone for use in establishing a data network telephony conference call, comprising in combination:  
a network interface linking a first data network telephone to a data network, wherein the data network includes a plurality of data network telephones with which the first data  
5 network telephone may be used to communicate voice data in a conference call;  
a PID interface for accepting PID data from a portable information device associated with a user, wherein the PID data includes at least one user identifier corresponding to at least one communication partner, and wherein the at least one communication partner is selected by the user via an address book application on the portable information device;  
10 a processor for constructing at least one invite message containing the at least one user identifier, wherein the invite message is used to invite the at least one communication partner to the conference call; and  
a user interface including an audio input and an audio output, wherein the user interface enables the user to communicate voice data with at least one communication partner  
15 associated with at least one of the plurality of data network telephones.

32. The data network telephone of Claim 31, wherein the PID data additionally includes non-voice-data that may be communicated to the at least one communication partner to enable the at least one communication partner to receive the non-voice data on at least once communication partner portable information device.

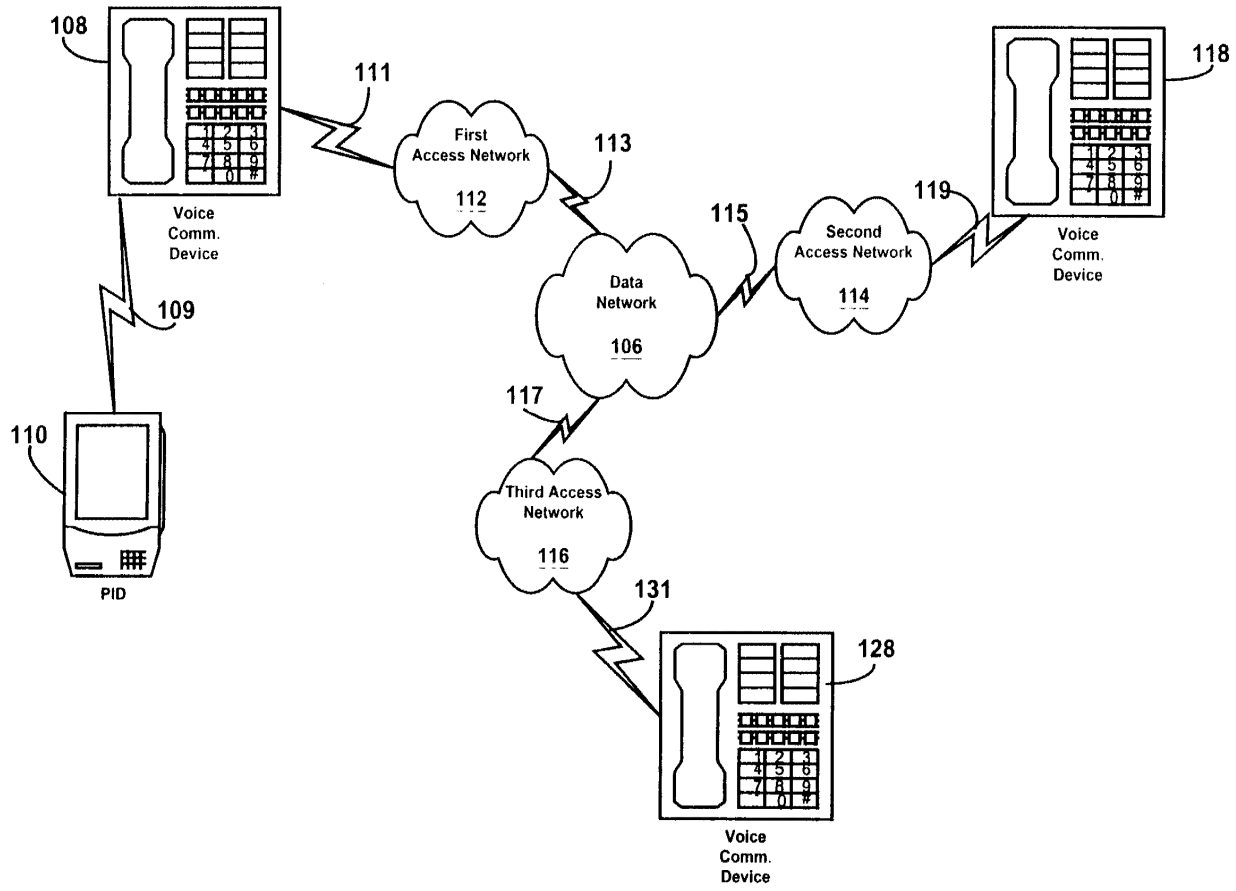
33. The method of Claim 31, wherein the portable information device is a personal digital assistant (PDA).

34. The method of Claim 31, wherein the portable information device is a wireless phone.

35. The method of Claim 31, wherein the data network is a public internet
36. The method of Claim 31, wherein the invite message is constructed according to the Session Initiation Protocol (SIP).
37. The method of Claim 31, wherein the invite message is constructed according to the H.323 protocol.
38. The method of Claim 31, wherein the invite message is constructed according to the MGCP protocol.
39. The method of Claim 31, wherein the invite message is constructed according to the MEGACO protocol.

FIG. 1

100



WO 01/24498

1 / 15

PCT/US00/41020



FIG. 2

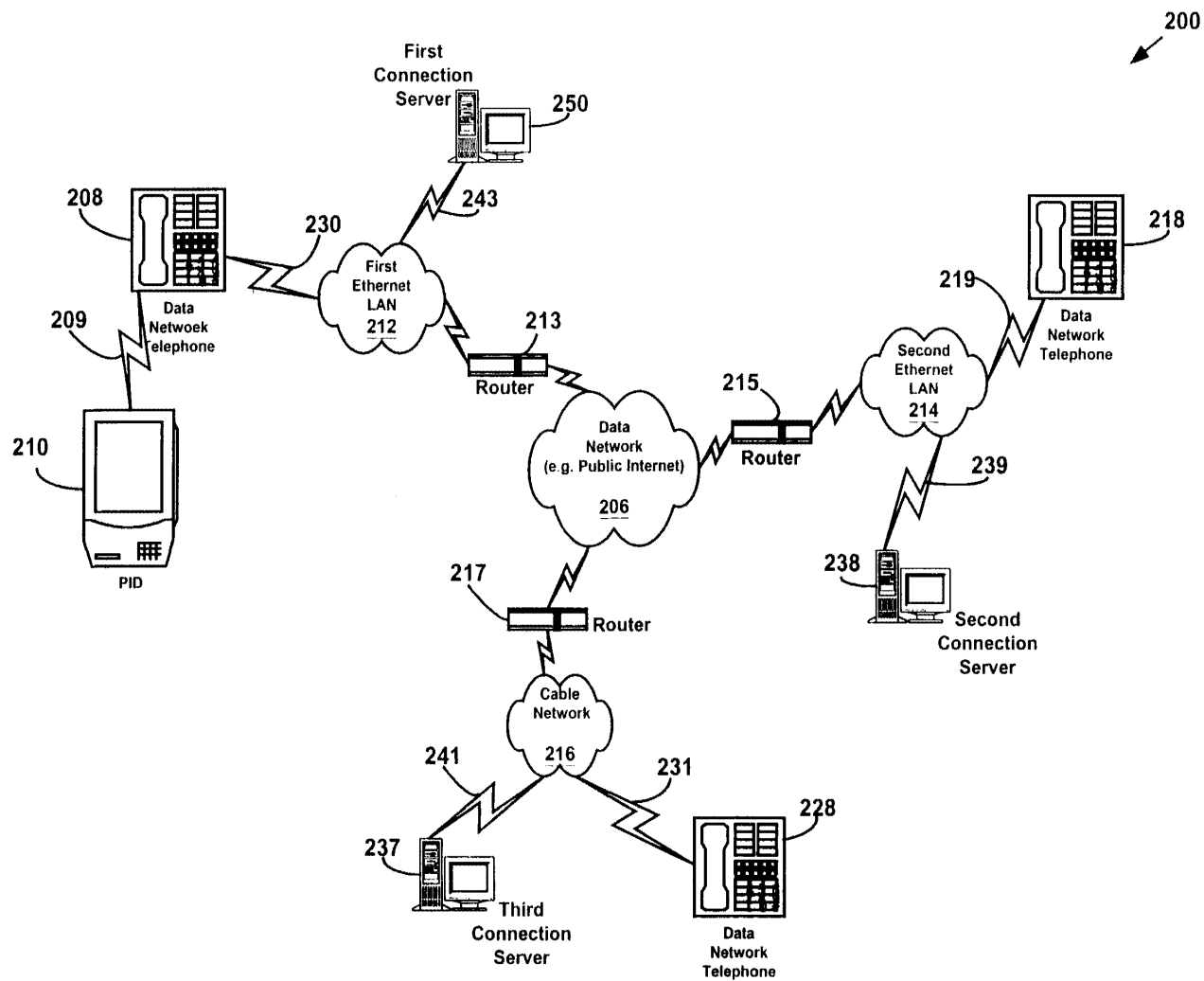


FIG. 3

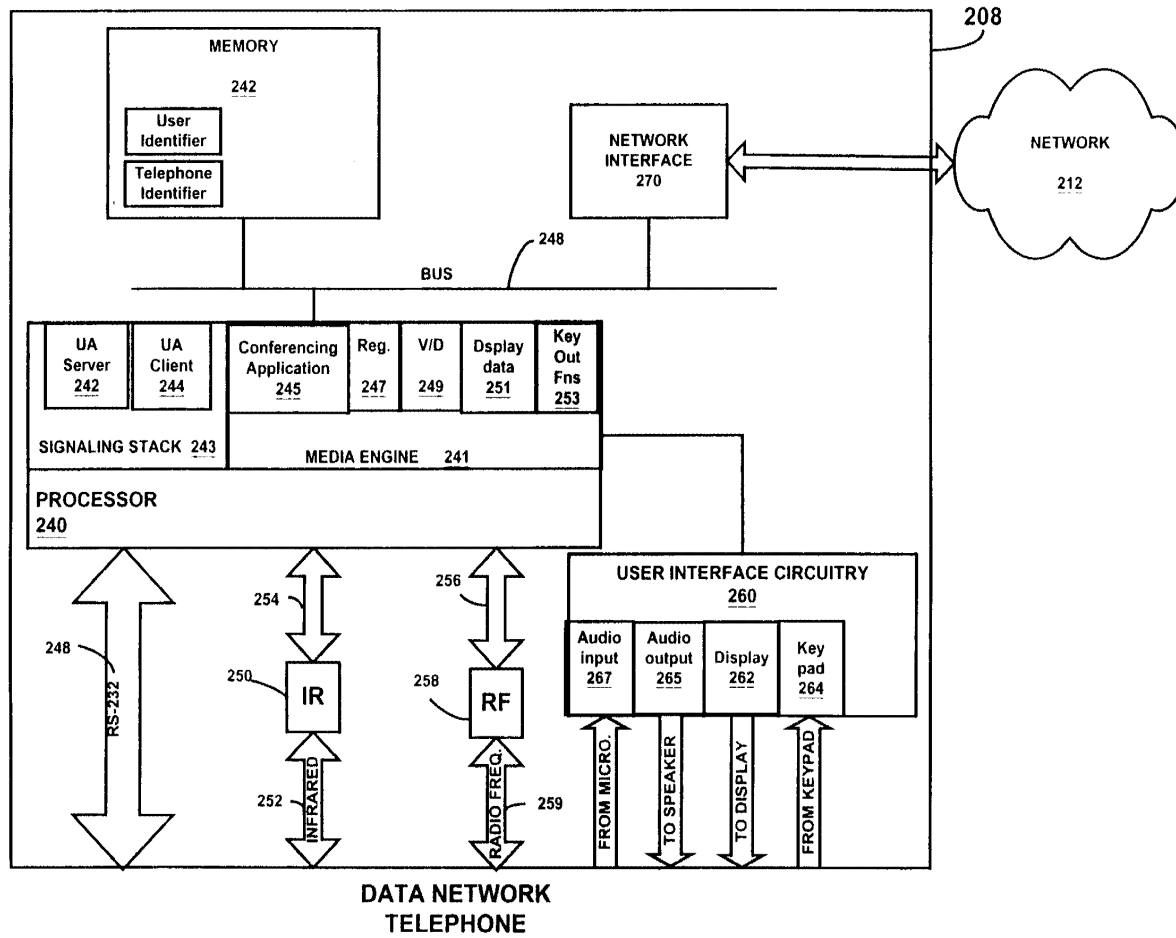
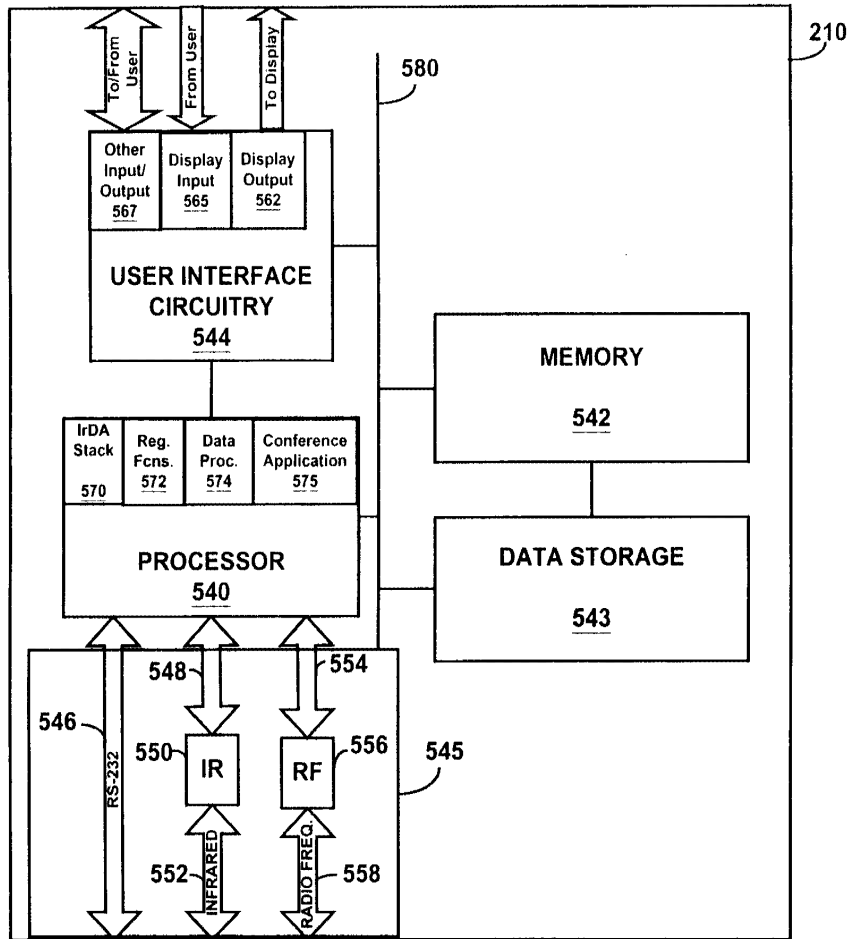


FIG. 4



PID

**FIG. 5**

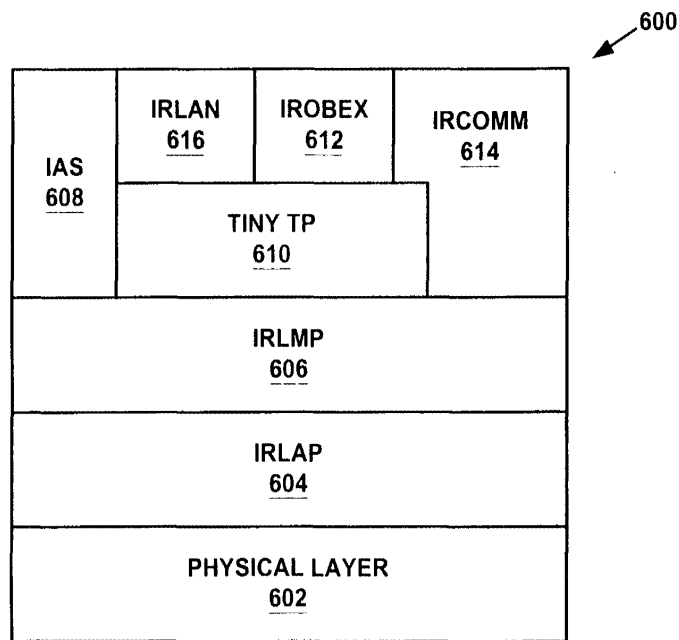


FIG. 6

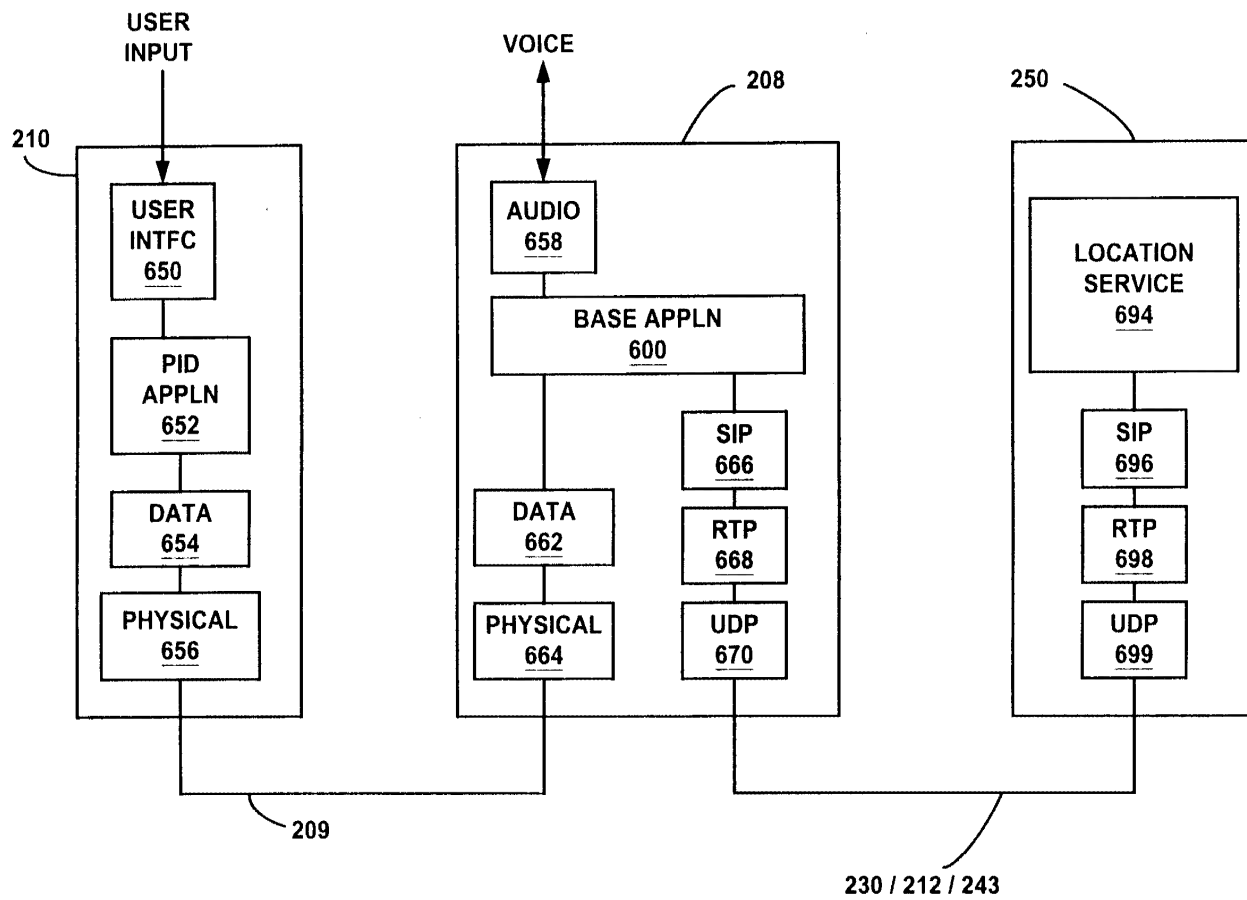
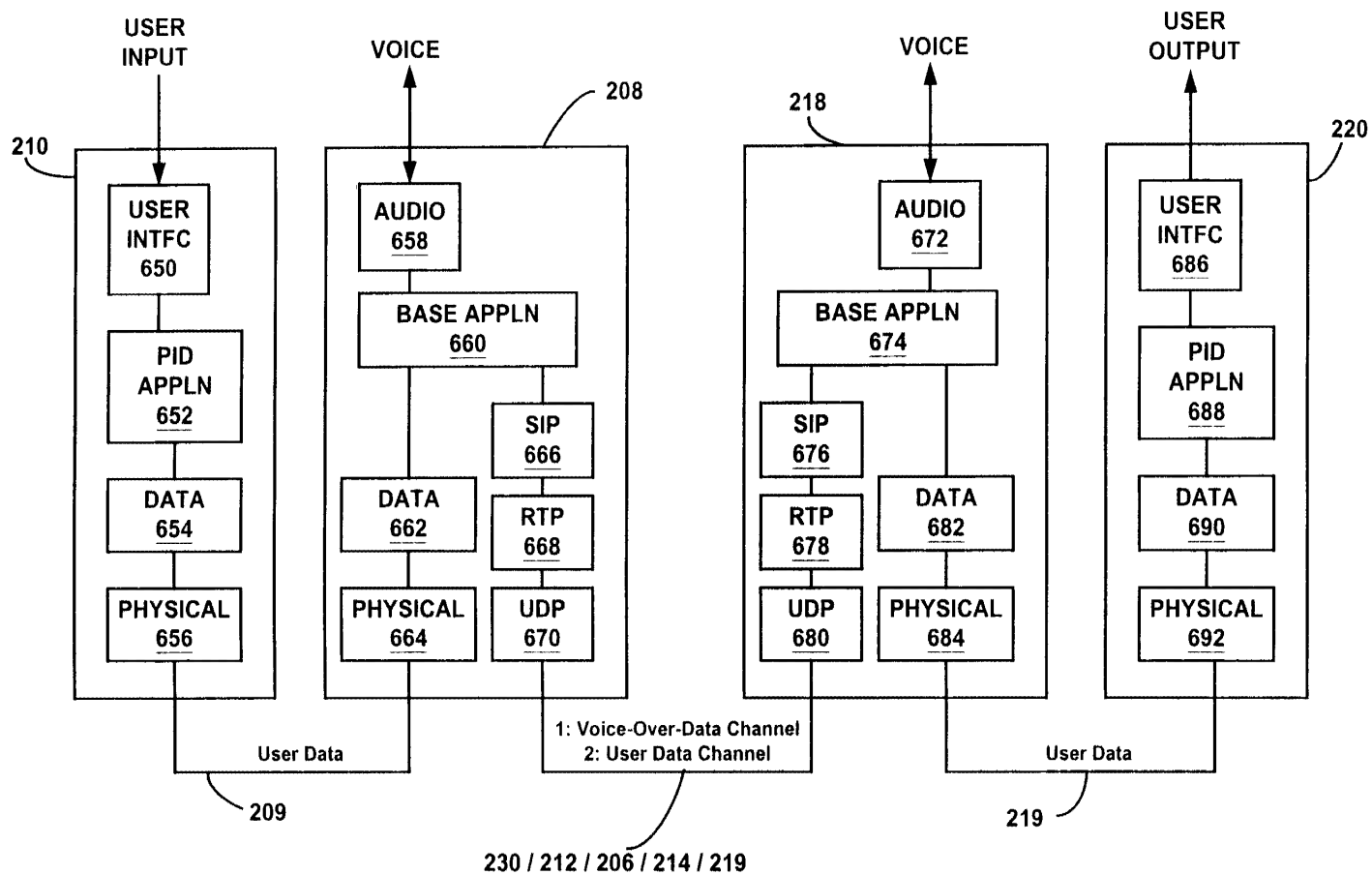


FIG. 7





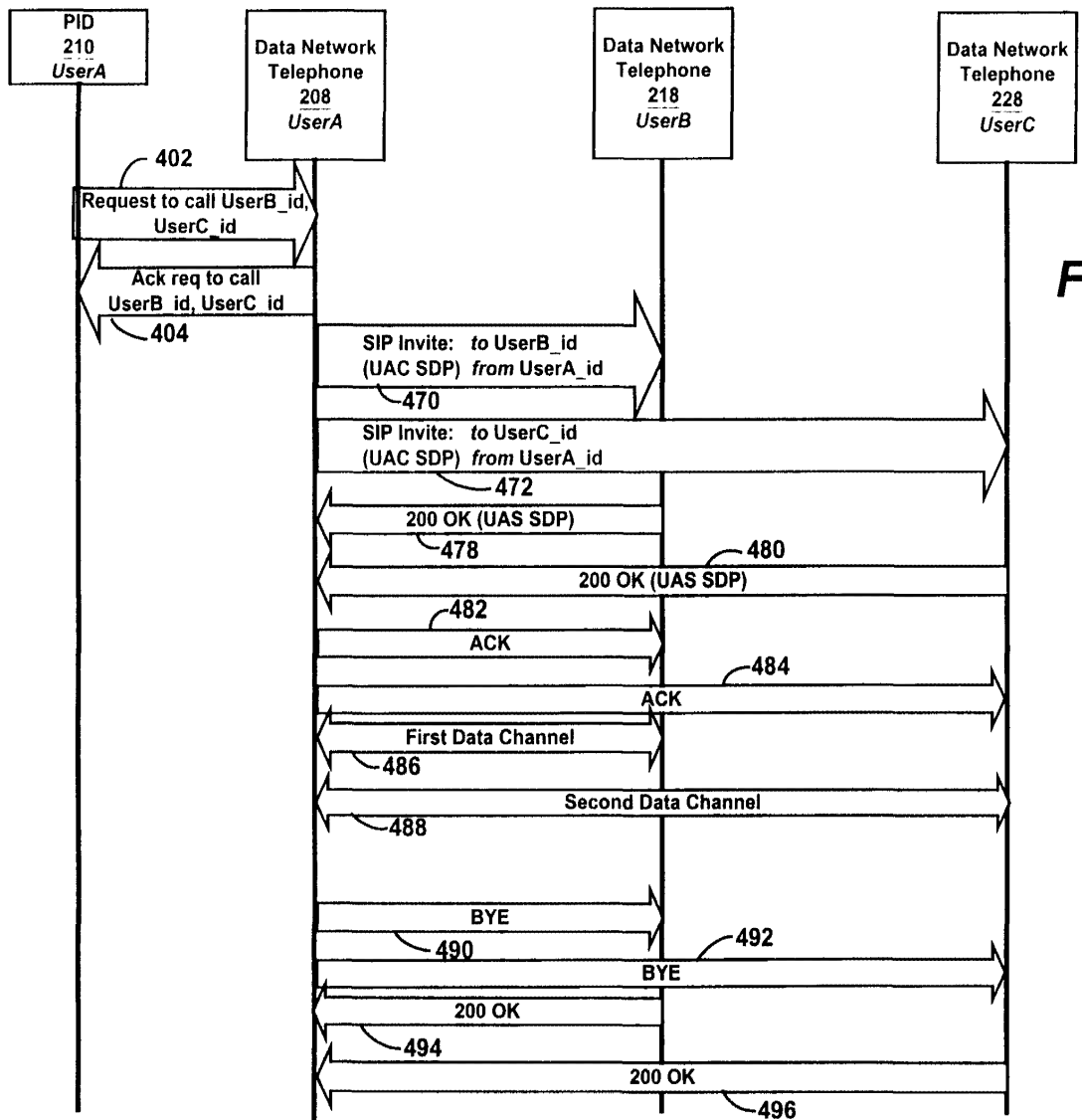
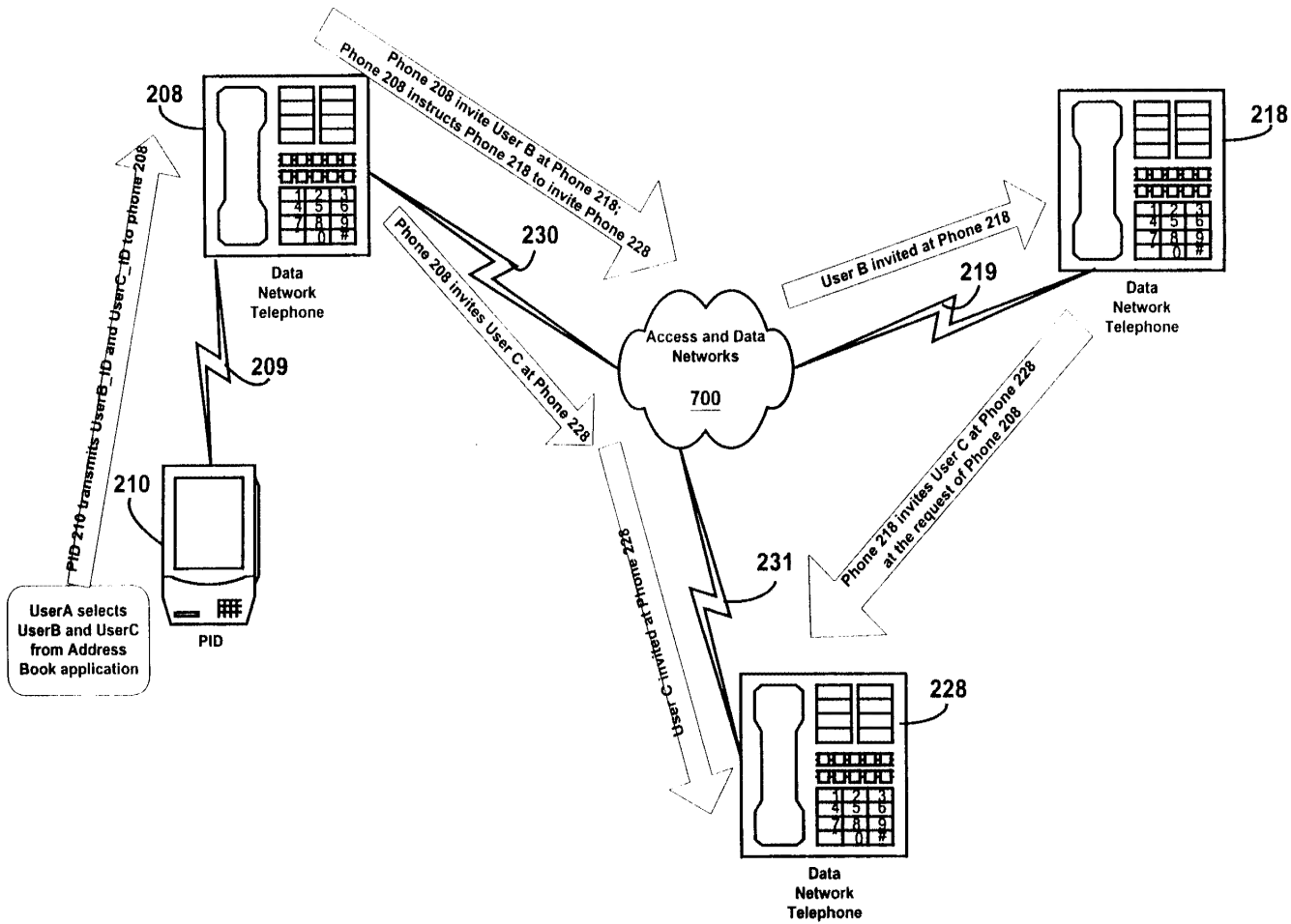


FIG. 8B



FIG. 9A

400



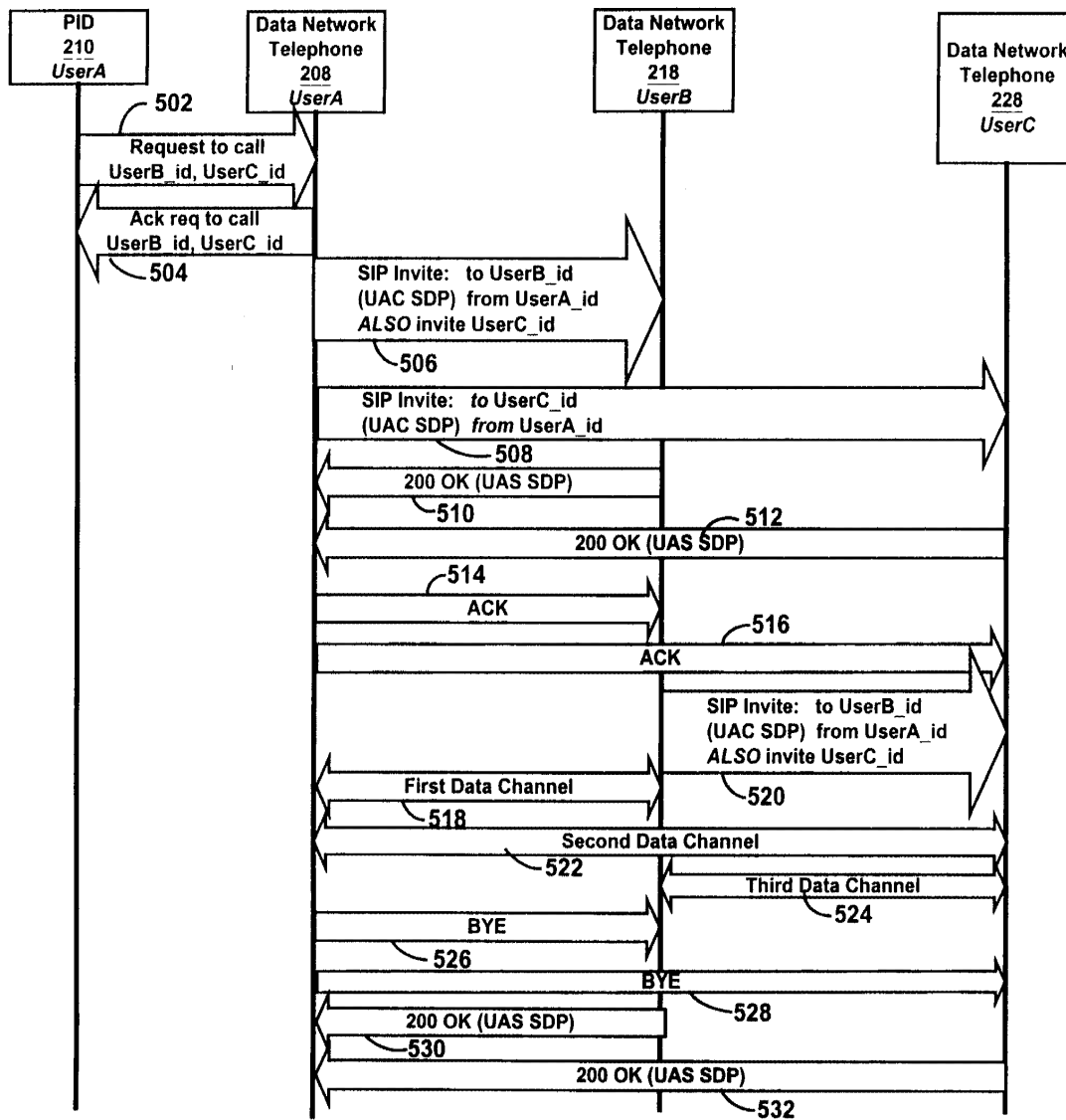
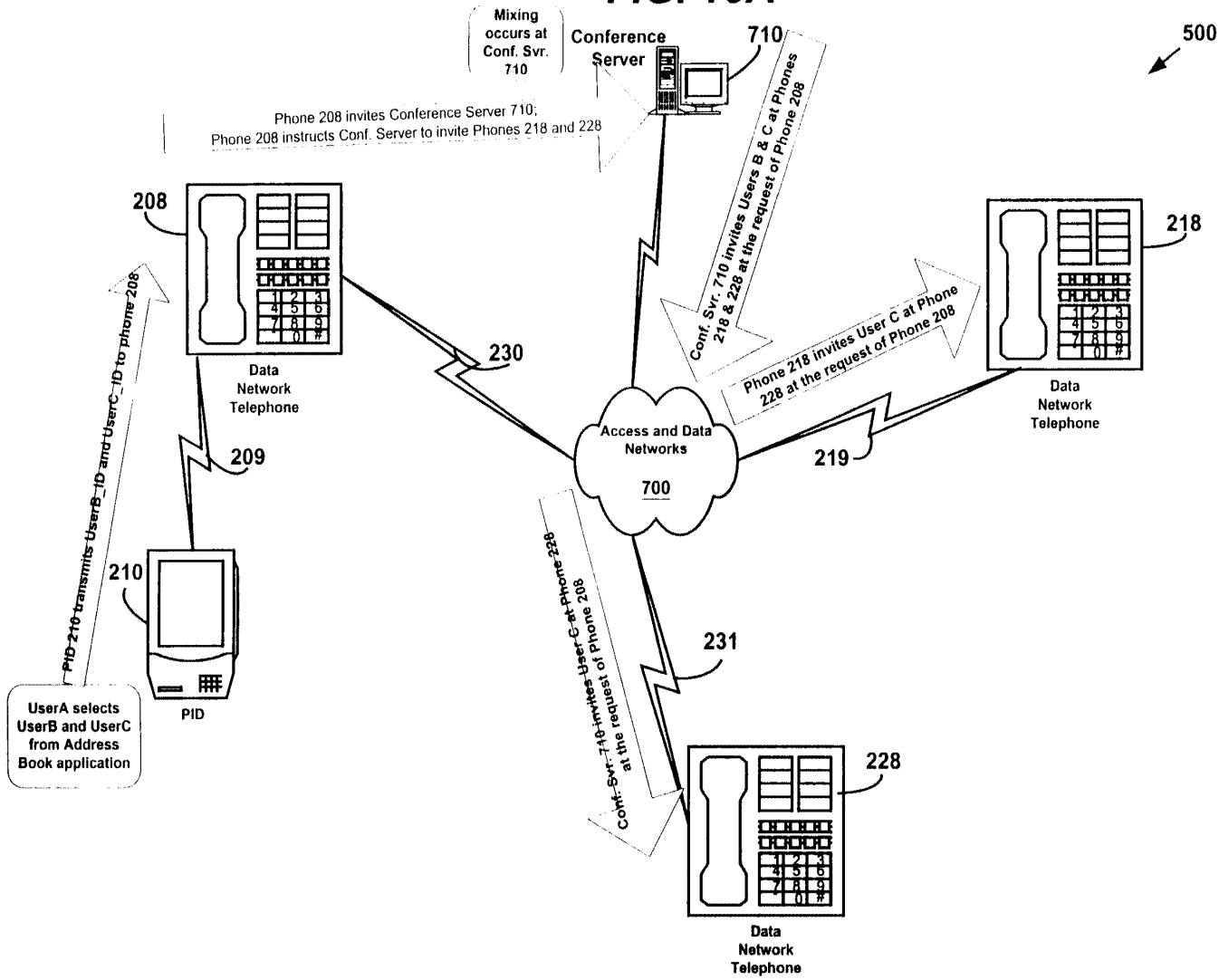
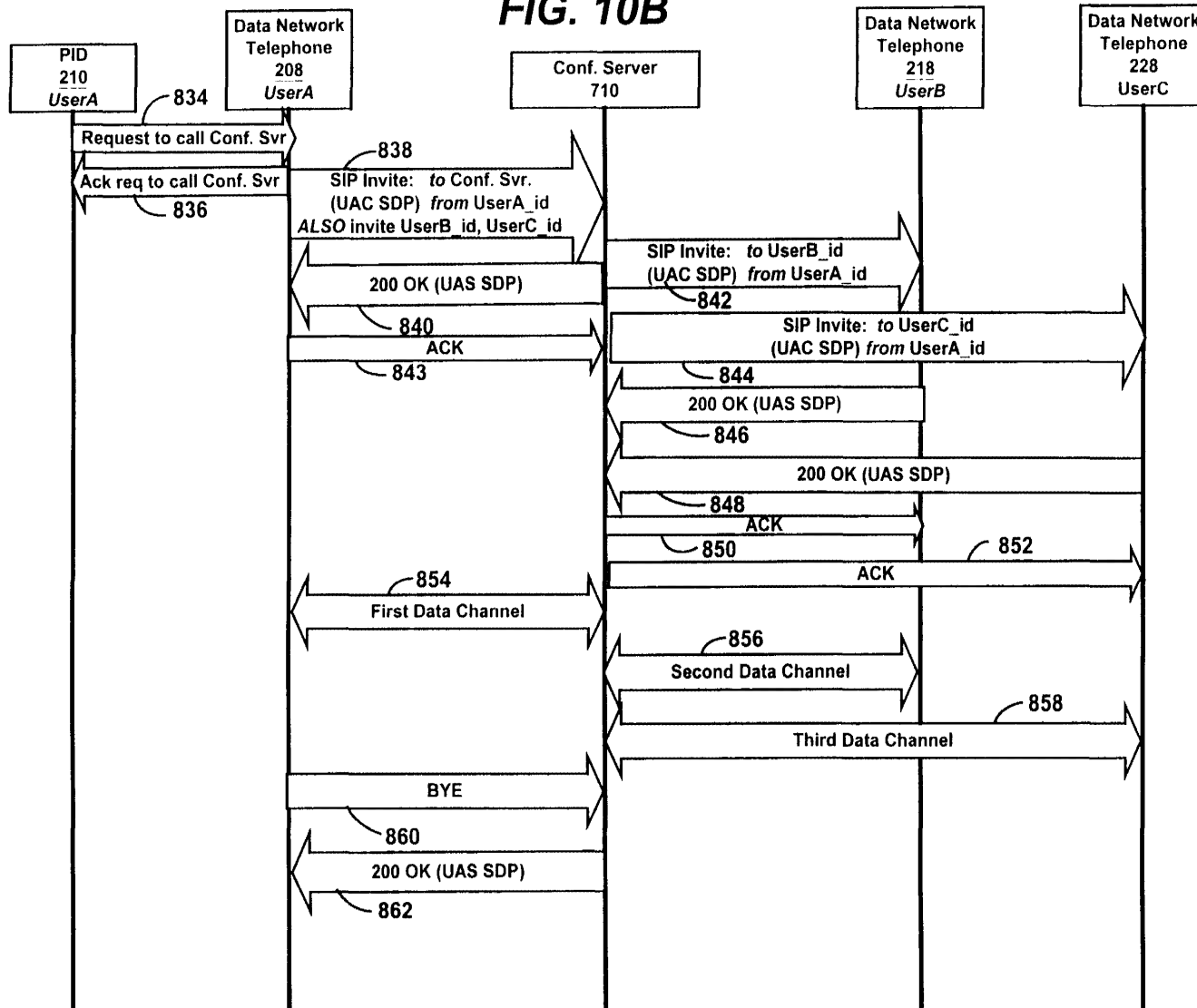


FIG. 9B

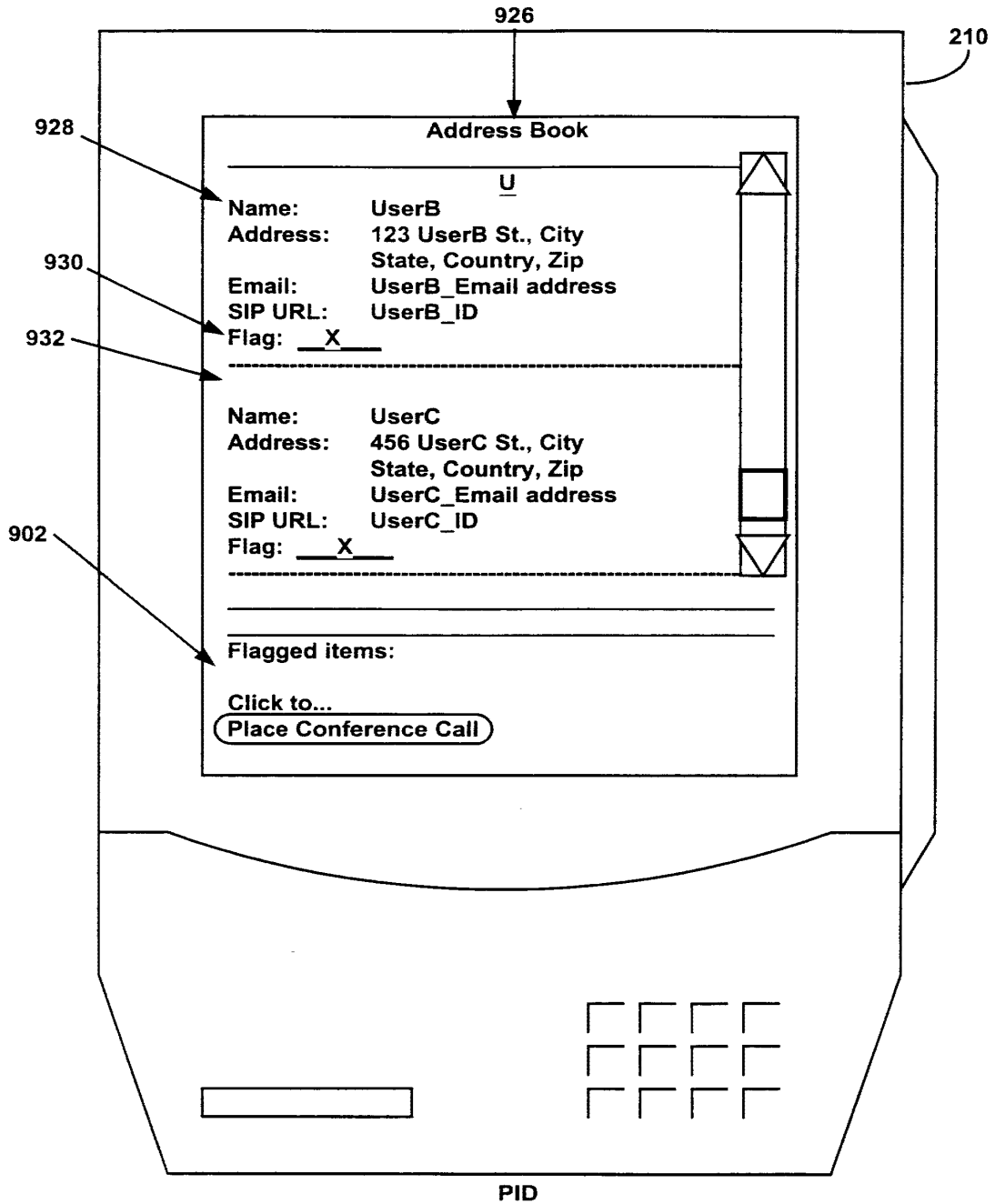
FIG. 10A



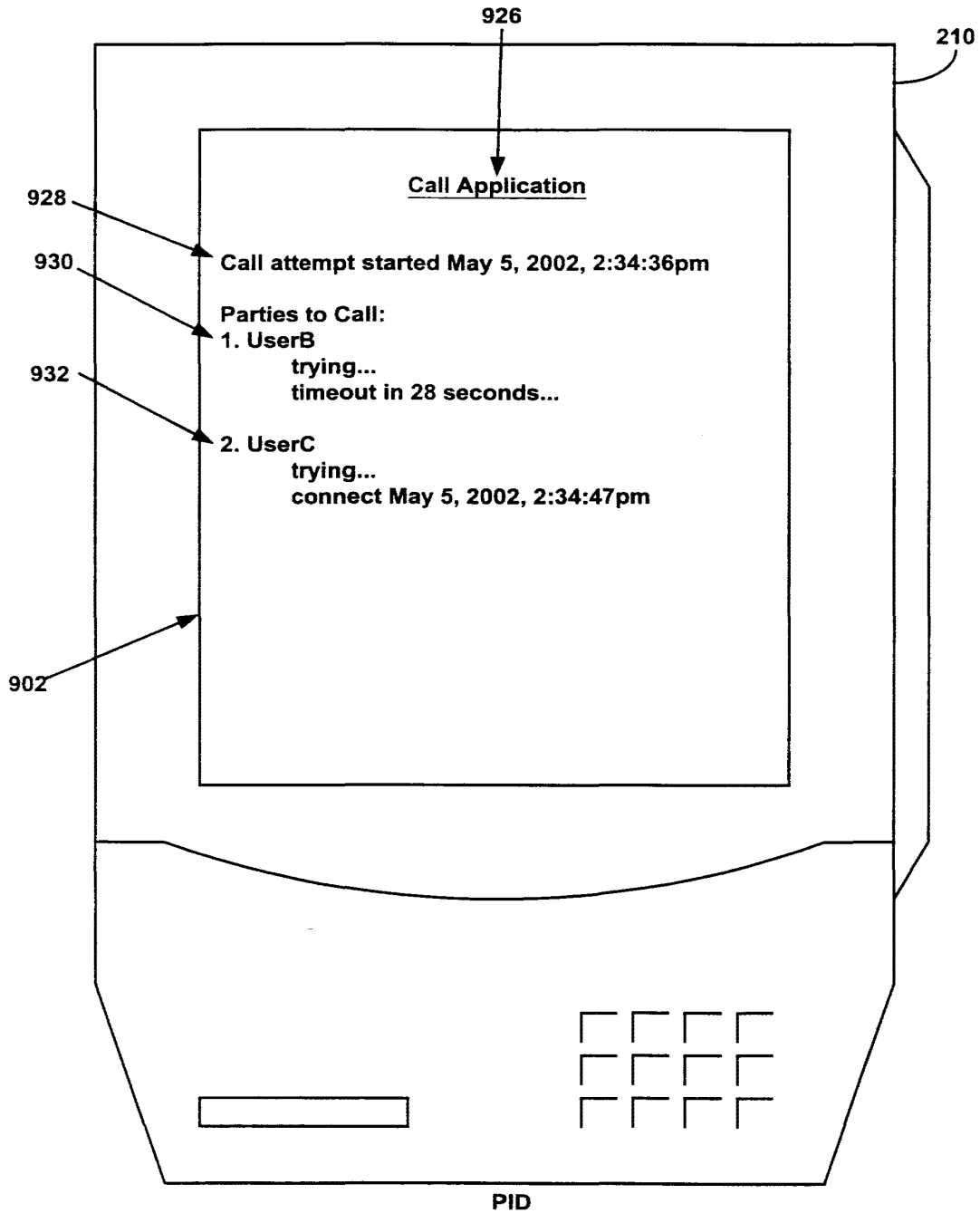
**FIG. 10B**



**FIG. 11**



**FIG. 12**





INTERNATIONAL SEARCH REPORT

International Application No  
PCT/US 00/41020

C.(Continuation) DOCUMENTS CONSIDERED TO BE RELEVANT		
Category	Citation of document, with indication, where appropriate, of the relevant passages	Relevant to claim No.
A	WO 98 37665 A (VAZIRI FARAMARZ ;WIMSATT JOHN D (US); FONEFRIEND SYSTEMS INC (US)) 27 August 1998 (1998-08-27) page 42, line 13 -page 21; figure 13 ---	1-39
A	PEPPER D J ET AL: "The CallManager system: A platform for intelligent telecommunications services" SPEECH COMMUNICATION,NL,ELSEVIER SCIENCE PUBLISHERS, AMSTERDAM, vol. 23, no. 1-2, 1 October 1997 (1997-10-01), pages 129-139, XP004117214 ISSN: 0167-6393 the whole document ---	1-39
A	ANQUETIL L -P ET AL: "MEDIA GATEWAY CONTROL PROTOCOL AND VOICE OVER IP GATEWAYS. MGCP AND VOIP GATEWAYS WILL OFFER SEAMLESS INTERWORKING OF NEW VOIP NETWORKS WITH TODAY'S TELEPHONE NETWORKS" ELECTRICAL COMMUNICATION,ALCATEL. BRUSSELS,BE, 1 April 1999 (1999-04-01), pages 151-157, XP000830045 ISSN: 0013-4252 the whole document -----	10,11, 23,24, 38,39



# INTERNATIONAL SEARCH REPORT

information on patent family members

International Application No <b>PCT/US 00/41020</b>
--

Patent document cited in search report	Publication date	Patent family member(s)	Publication date
WO 9912365    A	11-03-1999	SE    509926 C EP    1008266 A NO    20000902 A SE    9703121 A	22-03-1999 14-06-2000 27-04-2000 01-03-1999
-----			
WO 9837665    A	27-08-1998	AU    6666898 A EP    0966815 A	09-09-1998 29-12-1999
-----			

(19) World Intellectual Property Organization  
International Bureau



(43) International Publication Date  
5 April 2001 (05.04.2001)

PCT

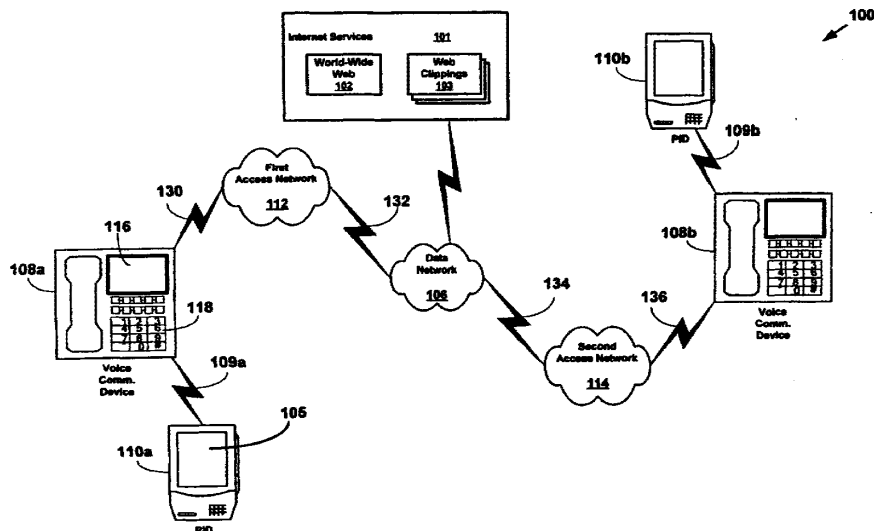
(10) International Publication Number  
WO 01/24500 A1

- (51) International Patent Classification<sup>7</sup>: H04M 7/00
- (21) International Application Number: PCT/US00/26594
- (22) International Filing Date:  
27 September 2000 (27.09.2000)
- (25) Filing Language: English
- (26) Publication Language: English
- (30) Priority Data:  
09/406,322 27 September 1999 (27.09.1999) US
- (63) Related by continuation (CON) or continuation-in-part (CIP) to earlier application:  
US 09/406,322 (CON)  
Filed on 27 September 1999 (27.09.1999)
- (71) Applicant (for all designated States except US): 3COM CORPORATION [US/US]; 3800 Golf Road, Rolling Meadows, IL 60008 (US).

- (72) Inventors; and
- (75) Inventors/Applicants (for US only): SCHUSTER, Guido, M. [CH/US]; Apartment 408, 1433 Perry Street, Des Plaines, IL 60016 (US). SIDHU, Ikhlaq, S. [US/US]; 403 River Grove Lane, Vernon Hills, IL 60061 (US). DEAN, Frederick, D. [US/US]; 2311 N. Greenview Avenue, Chicago, IL 60614 (US). BELKIND, Ronnen [US/US]; 1960 Lincoln Park West #2503, Chicago, IL 60614 (US).
- (74) Agent: PEREZ, Enrique; McDonnell Boehnen Hulbert & Berghoff, 32nd Floor, 300 South Wacker Drive, Chicago, IL 60606 (US).
- (81) Designated States (national): AE, AG, AL, AM, AT, AU, AZ, BA, BB, BG, BR, BY, BZ, CA, CH, CN, CR, CU, CZ, DE, DK, DM, DZ, EE, ES, FI, GB, GD, GE, GH, GM, HR, HU, ID, IL, IN, IS, JP, KE, KG, KP, KR, KZ, LC, LK, LR, LS, LT, LU, LV, MA, MD, MG, MK, MN, MW, MX, MZ, NO, NZ, PL, PT, RO, RU, SD, SE, SG, SI, SK, SL, TJ, TM, TR, TT, TZ, UA, UG, US, UZ, VN, YU, ZA, ZW.
- (84) Designated States (regional): ARIPO patent (GH, GM, KE, LS, MW, MZ, SD, SL, SZ, TZ, UG, ZW), Eurasian

[Continued on next page]

(54) Title: SYSTEM AND METHOD FOR ACCESSING AN INTERNET SERVER USING A PORTABLE INFORMATION DEVICE -PDA THROUGH A DATA NETWORK TELEPHONE



(57) Abstract: A system and method for using a personal information device (PID) to access Internet services over a data network using a telephone. The user may select a hotlink or URL on a display screen on the PID. A communications application transmits the hotlink as PID data to the telephone. The telephone is configured to establish a data communications channel upon receipt of the PID data. The PID data is sent to the Internet services. The Internet Services respond by downloading data associated with the request in the PID data.



WO 01/24500 A1



patent (AM, AZ, BY, KG, KZ, MD, RU, TJ, TM), European patent (AT, BE, CH, CY, DE, DK, ES, FI, FR, GB, GR, IE, IT, LU, MC, NL, PT, SE), OAPI patent (BF, BJ, CF, CG, CI, CM, GA, GN, GW, ML, MR, NE, SN, TD, TG).

— Before the expiration of the time limit for amending the claims and to be republished in the event of receipt of amendments.

**Published:**

— With international search report.

For two-letter codes and other abbreviations, refer to the "Guidance Notes on Codes and Abbreviations" appearing at the beginning of each regular issue of the PCT Gazette.

**APPLICATION FOR A UNITED STATES PATENT**

UNITED STATES PATENT AND TRADEMARK OFFICE

5

(MBHB Case No. 99,593; 3Com Case No. 2620.S4.US.P)

10

Title: SYSTEM AND METHOD FOR ACCESSING AN INTERNET SERVER USING A PORTABLE  
INFORMATION DEVICE -PDA THROUGH A DATA NETWORK TELEPHONE

15

20

25

30

**SYSTEM AND METHOD FOR ACCESSING A NETWORK SERVER USING A  
PORTABLE INFORMATION DEVICES THROUGH A NETWORK BASED  
TELECOMMUNICATION SYSTEM**

5

**A. Field of the Invention**

The present invention relates to a system and method for providing communication services over a network. In particular, the present invention relates to a system and method for providing communication between a portable information devices (PIDs) and a network server through a network connected telecommunication device.

**B. Description of the Related Art**

For many years, telephone service providers on the Public Switched Telephone Network (PSTN) provided their customers nothing more than a telephone line to use to communicate with other subscribers. Over time, telephone service providers have enhanced their service by providing Custom Local Area Signaling Service (CLASS) features to their customers. Similar communication services are provided by a Private Branch Exchange (PBX), which is typically implemented in a nonresidential setting.

The CLASS features permit customer subscribers of the features to tailor their telephone service according to individual needs. Some of the more well-known CLASS features are:

- Call blocking: The customer may specify one or more numbers from which he or she does not want to receive calls. A blocked caller will hear a rejection message, while the callee will not receive any indication of the call.
- Call return: Returns a call to the most recent caller. If the most recent caller is busy, the returned call may be queued until it can be completed.
- Call trace: Allows a customer to trigger a trace of the number of the most recent caller.
- Caller ID: The caller's number is automatically displayed during the silence period after the first ring. This feature requires the customer's line to be equipped with a device to read and display the out-of-band signal containing the number.

- Caller ID blocking: Allows a caller to block the display of their number in a callee's caller ID device.

- Priority ringing: Allows a customer to specify a list of numbers for which, when the customer is called by one of the numbers, the customer will hear a distinctive ring.

- Call forwarding: A customer may cause incoming calls to be automatically forwarded to another number for a period of time.

A customer subscriber to a CLASS feature may typically activate and/or deactivate a CLASS feature using "\*" directives (e.g., \*69 to automatically return a call to the most recent caller). CLASS features may also be implemented with the use of out-of-band data. CLASS feature data is typically transmitted between local Class-5 switches using the Signaling System 7 (SS7).

Local Exchange Carriers (LECs) and other similar organizations maintain CLASS offices that typically contain a database entry for each customer. The database allows specification of the CLASS features a customer has subscribed to, as well as information, such as lists of phone numbers, associated with those features. In some cases, customers may edit these lists on-line via a touch-tone interface. A list of all phone numbers that have originated or terminated a call with each customer is often included in the CLASS office database. For each customer, usually only the most recent number on this list is stored by the local Class-5 switch.

A Private Branch Exchange (PBX), is a stored program switch similar to a Class-5 switch. It is usually used within a medium-to-large-sized business for employee telephony service. Since a PBX is typically operated by a single private organization, there exists a wide variety of PBX services and features. Custom configurations are common, such as integration with intercom and voice mail systems. PBX's typically support their own versions of the CLASS features, as well as other features in addition to those of CLASS. Most PBX features are designed to facilitate business and group communications.

A summary of typical PBX features includes:

- Call transfer: An established call may be transferred from one number to another number on the same PBX.

- Call forwarding: In addition to CLASS call forwarding, a PBX number can be programmed to automatically transfer a call to another number when the first number does not answer or is busy.

- Camp-on queuing: Similar to PSTN call return, a call to a busy number can be queued until the callee can accept it. The caller can hang up their phone and the PBX will ring them when the callee answers.

- Conference calling: Two or more parties can be connected to one another by dialing into a conference bridge number.

- Call parking: An established call at one number can be put on hold and then reestablished from another number. This is useful when call transfer is not warranted.

- Executive override: A privileged individual can break into an established call. After a warning tone to the two participants, the call becomes a three-way call.

While the CLASS and PBX features have enhanced the offerings of service providers that use the PSTN, the features are nevertheless limited in their flexibility and scope. The effect to the user is that the features become clumsy and difficult to use. For example, in order to use the Call Forwarding function, the user must perform the steps at the user's own phone prior to moving to the location of the telephone to which calls will be forwarded. A more desirable approach, from the standpoint of usefulness to the user, would be to perform the steps at the telephone to which calls will be forwarded.

Much of the lack of flexibility of the PSTN features is due to the lack of flexibility in the PSTN system itself. One problem with the PSTN is that the terminal devices (e.g. telephones) lack intelligence and operate as "dumb" terminals on a network having the intelligence in central offices. Most PSTN telephones are limited in functional capability to converting the analog signals they receive to sound and converting the sound from the handset to analog signals.

Some PSTN telephones have a display device and a display function to display specific information communicated from intelligent agents in the PSTN network using the PSTN signaling architecture. For example, some PSTN telephones have a display function to enable the Caller ID feature. Even such PSTN telephones are limited however by the closed PSTN signaling architecture, which prohibits access by the PSTN

telephones to the network signaling protocols. The display functions are effectively limited to displaying text, again, as a “dumb” terminal.

The Internet presents a possible solution for distributing intelligence to telephony terminal devices. In Internet telephony, digitized voice is treated as data and transmitted  
5 across a digital data network between a telephone calls’ participants. One form of Internet telephony uses a telephony gateway/terminal where IP telephony calls are terminated on the network. PSTN telephones are connected by a subscriber line to the gateway/terminal at the local exchange, or at the nearest central office. This form of Internet telephony provides substantial cost savings for users. Because the PSTN portion  
10 used in Internet telephony calls is limited to the local lines on each end of the call, long distance calls may be made for essentially the cost of a local call. Notwithstanding the costs savings provided by this form of Internet telephony, it is no more flexible than the PSTN with respect to providing enhancements and features to the basic telephone service.

15 In another form of Internet telephony, telephones are connected to access networks that access the Internet using a router. The telephones in this form of Internet telephony may be substantially more intelligent than typical PSTN telephones. For example, such a telephone may include substantially the computer resources of a typical personal computer.

20 It would be desirable to incorporate CLASS and PBX features into a data network telephony system that uses a data network such as the Internet.

It would be desirable to provide new features and enhancements to telephony service that accommodates and conforms to users’ needs.

25 It would also be desirable to provide features and capabilities to telephone service that create new opportunities for users and for service providers.

The present invention addresses the above needs by providing a system in a data network telephony system, such as for example, the Internet, that enables users to connect to Internet services using a personal information device.



### BRIEF DESCRIPTION OF THE DRAWINGS

Presently preferred embodiments of the invention are described below in conjunction with the appended drawing figures, wherein like reference numerals refer to like elements in the various figures, and wherein:

5           FIG. 1 is block diagram of a network telephony system according to one embodiment of the present invention;

          FIG. 2 is a block diagram showing a system for using a portable information device (PID) to connect to Internet services on a telephony system according to an exemplary embodiment of the present invention;

10           FIG. 3 is a block diagram of a data network telephone according to an exemplary embodiment of the present invention;

          FIG. 4 is a block diagram of a PID according to an exemplary embodiment of the present invention;

          FIG. 5 is a stack layer diagram showing the layers of an IrDA stack;

15           FIG. 6 is a block and stack layer diagram illustrating an embodiment of the protocol stacks in an exemplary embodiment of a PID linked to a data network telephone;

          FIG. 7A is block and stack layer diagram illustrating an embodiment of the present invention in which a connection to an Internet service may be established;

          FIG. 7B is a block and stack layer diagram illustrating an alternative embodiment  
20 of the present invention in which a connection to an Internet service may be established;  
and

          FIG. 8 is a combined block and pictorial diagram showing advantageous use of a system for providing PID data exchange according to one embodiment of the present  
invention.

25

**DETAILED DESCRIPTION OF THE PREFERRED EMBODIMENT**

The following references to patent applications filed concurrently herewith are incorporated by reference:

- 5 \* "System and Method for Controlling Telephone Service Using a Wireless Personal Information Device" to Schuster, et al.
- \* "System and Method for Advertising Using Data Network Telephone Connections" to Schuster, et al.
- \* "System and Method for Providing User-Configured Telephone Service in a Data Network Telephony System" to Sidhu, et al.
- 10 \* "System and Method for Interconnecting Portable Information Devices Through a Network Based Telecommunication System" to Schuster, et al.
- \* "System and Method for Enabling Encryption on a Telephony Network" to Schuster, et al.
- \* "System and Method for Using a Portable Information Device to Establish a  
15 Conference Call on a Telephony Network" to Schuster, et al.
- \* "System and Method for Associating Notes with a Portable Information Device on a Network Telephony Call" to Schuster, et al.
- \* "System and Method for Providing Shared Workspace Services Over a Telephony Network" to Schuster, et al.
- 20 \* "System and Method for Providing Service Provider Configurations for Telephones in a Data Network Telephony System" to Schuster, et al.

The following additional references are also incorporated by reference herein:

- \* "Multiple ISP Support for Data Over Cable Networks" to Ali Akgun, et al.
- \* "Method and System for Provisioning Network Addresses in a Data-Over-Cable  
25 System" to Ali Akgun, et al., Serial No. 09/218,793.
- \* "Network Access Methods, Including Direct Wireless to Internet Access" to Yingchun Xu, et al., Serial No. 08/887,313

30

### A. PID-Enabled Data Network Telephony System

FIG. 1 is a block diagram showing an exemplary embodiment of a system 100 for connecting to Internet services according to one embodiment of the present invention.

The system includes a data network 106. A first voice communication device 108a linked to a first access network 112 via connection 130 may communicate over the data network 106 by connecting via the first access network 112. A second voice communication device 108b is linked to a second access network 114 through connection 136 and may communicate over the data network 106 by connecting via the second access network 114

The data network 106 in the system 100 typically includes one or more Local Area Networks (LANs) connected to one another or to a Wide-Area Network (WAN), such as an Internet Protocol (IP) network, to provide wide-scale data connectivity. The data network 106 may use Voice Over Packet (VOP) schemes in which voice signals are carried in data packets. The network 106 may also include a connection to the Public Switched Telephone Network (PSTN) to allow for voice connections using traditional circuit switching techniques. In one embodiment, the data network 106 may include one or more LANs such as Ethernet LANs and support data transport protocols for performing Voice-over-Internet-Protocol (VoIP) techniques on the Internet. For further details regarding VoIP, see the information available through the Internet Engineering Task Force (IETF) at [www.ietf.org](http://www.ietf.org). In addition, an Internet Telephony gateway may be included within the system 100 to allow for voice connections to users connected by subscriber lines at a PSTN Central Office.

The data network 106 may be used to access a variety of Internet services 101. For example, the Internet includes the World-Wide Web 102, which is a well-known system for exchanging data over the Internet. The World-Wide Web 102 is commonly used to access targeted information using a computer workstation and an application on the workstation called a browser. With respect to PID's, many Internet Content Providers offer a variety of Web clippings 103 to permit viewing World-Wide Web data on a PID which is smaller than a workstation. One advantage of the system 100 in FIG. 1 is that web clippings 103 and other Internet services 101 may be accessed using the PID 110a,b without having to place a telephone call over the wireless cellular network.

The voice communication devices 108a-b (described further below with reference to FIG. 3) typically include a voice input, a voice output and a voice processing system. The voice processing system converts voice sound to digital data signals that are communicated on a voice connection over the data network. The voice processing system also converts digital data signals received from the voice connection to voice sound. The voice communication devices 108a-b typically include a central processing unit and memory to store and process computer programs. Additionally, each voice communication device 108a-b typically includes a unique network address, such as an IP address, in memory to uniquely identify it to the data network 106 and to permit data packets to be routed to the device.

A first PID 110a linked to the first voice communication device 108a via connection 109a may communicate over the data network 106 by connecting via the first access network 112. A second PID 110b linked to the second voice communication device 108b via connection 109b may communicate over the data network 106 by connecting via the second access network 114. The PIDs 110a-b each contain user attributes stored in a user information data base. The user attributes may contain such information as a user identifier, schedule information, and other information that is associated with a user of the PID 110a or 110b. The PIDs 110a-b each include a user interface allowing a user to easily enter and retrieve data. In a preferred embodiment, the user interface includes a pressure-sensitive display that allows a user to enter input with a stylus or other device. An example of a PID with such an interface is a PDA (Personal Digital Assistant), such as one of the Palm™ series of PDAs offered by 3Com® Corporation. The PIDs 110a-b may include other functionality, such as wireless phone or two-way radio functionality.

Links 109a-b are point-to-point links, and may be entirely or partially wireless, or they may be hard-wired connections. Each of the links 109a-b is preferably a wireless link, such as an infrared link specified by the Infrared Data Association (IrDA) (see [irda.org](http://irda.org) for further information) or a radio frequency (RF) link such as the Bluetooth system (see [www.bluetooth.com](http://www.bluetooth.com) for further information). However, the point-to-point link can also be a hardwired connection, such as an RS-232 serial port.

In one embodiment, the voice communication device 108a includes a handset with a receiver and transmitter similar or identical to handsets of traditional circuit-switched telephones. A console on which the handset sits may include the voice processing system, a display 116, and a keypad 118.

5 In a preferred embodiment, a portion of the voice communication device 108a utilizes an NBX 100™ communication system phone offered by 3Com® Corporation. In alternative embodiments, the voice communication device 108a may include any device having voice communications capabilities. For example, a personal computer having a microphone input and speaker output may also be used to implement the voice  
10 communication device 108a. Other configurations are also intended to be within the scope of the present invention.

The details relating to operation of the voice communication devices 108a and 108b depend on the nature of the data network 106 and the nature of the access networks 112, 114 connecting the voice communication devices 108a and 108b to each other  
15 and/or to other network entities. The access networks 112, 114 typically include any high bandwidth network adapted for data communications, i.e. a network having greater than 64,000 bits-per-second (bps) bandwidth. The access networks 112, 114 may link to the voice communication devices 108a-b using an Ethernet LAN, a token ring LAN, a coaxial cable link (e.g. CATV adapted for digital communication), a digital subscriber  
20 line (DSL), twisted pair cable, fiberoptic cable, an integrated services digital network (ISDN) link, and wireless links. In embodiments that may not require bandwidth greater than 64,000 bps, the access networks 112, 114 may also include the PSTN and link the voice communications devices 108a-b by an analog modem.

#### 25 **B. System for Connecting to Data Network Services Using a Data Network Telephony System**

One advantage of the PID-Enabled Data Network Telephony System 100 in FIG. 1 is that it may be used to provide PID connectivity to the data network 106. In one embodiment, the PIDs 110a are able to connect to data network services through a user interface on the PID 110a. The PID 110a includes a web application for retrieving  
30 information that can be communicated from the Internet services 101 over the data network 106, transported across the first access network 112, to the voice communication

device 108a. The PID 110a can receive the information across the link 109a for display on the PID 110ba.

In one embodiment, the PID 110a uses the Point-to-Point Protocol (PPP) to communicate with the voice communications device 108a. The PID 110a communicates requests for services to the voice communications device 108a to send over the data network 106. The PID 110a receives the Internet service offerings (*e.g.* web clippings) from the data network through the voice communication device 108a.

A voice-over-data channel for communicating voice-over-data may or may not concurrently exist with this communication of information over a data channel. In this way, a user of the PID 110a can receive information from the Internet services 101 while voice signals are communicated between the voice communication device 108a and the voice communication device 108b. Alternatively, the user may use the PID 110a connection to the Internet services independently of any telephone calls.

#### 1. Local Area Network As An Exemplary Access Network

FIG. 2 is a block diagram showing one example of the system 100 of FIG. 1 for accessing Internet services 101 using a PID 210a according to the present invention. The system 200 in FIG. 2 includes a local area network 212, connected to a data network 206 by a first router 228. A cable network 214 is connected to the data network 206 by a second router 238. Those of ordinary skill in the art will appreciate that while FIG. 2 illustrates the access networks as the local area network 212 and the cable network 214, any other type of network may be used. For example, the local area network 212 and/or the cable network 214 may be replaced by ISDN, DSL, or any other high-speed data link.

The local area network 212 provides data connectivity to its network elements, such as a first data network telephone 208a, a second data network telephone 208b, and a first network telephony connection server 150. The local area network 212 in FIG. 2 is an Ethernet LAN operating according to the IEEE 802.3 specification, which is incorporated by reference herein, however, any other type of local area network may be used. The local area network 212 uses the router 228 to provide the data network telephone 208a and the first network telephony connection server 150 with access to the data network 206. For example, the router 228 may perform routing functions using

protocol stacks that include the Internet Protocol and other protocols for communicating on the Internet.

The first network telephony connection server 150 provides telephony registration, location and session initiation services for voice connections in which its members are a party. A user may register for telephony service with an administrator of the first network telephony connection server 150 and receive a user identifier and a telephone identifier. The user identifier and telephone identifier may be sequences of unique alphanumeric elements that callers use to direct voice connections to the user. The first network telephony connection server 150 registers users by storing user records in a first registration database 152 in response to registration requests made by the user.

The call setup process and the user and telephone identifiers preferably conform to requirements defined in a call management protocol. The call management protocol is used to permit a caller anywhere on the data network to connect to the user identified by the user identifier in a data network telephone call. A data network telephone call includes a call setup process and a voice exchange process. The call setup process includes steps and message exchanges that a caller and callee perform to establish the telephone call. The actual exchange of voice signals is performed by a data communications channel. The data communications channel incorporates other data transport and data formatting protocols, and preferably includes well-known data communications channels typically established over the Internet.

The call management protocol used in FIG. 2 is the Session Initiation Protocol (SIP), which is described in M. Handley et al., "SIP: Session Initiation Protocol," IETF RFC 2543, Mar. 1999, incorporated by reference herein, however, any other such protocol may be used. Other protocols include H.323, the Media Gateway Control Protocol (MGCP), MEGACO, etc.

The network telephony connection server 150 may be used to provide telephony service for mobile users. A user may be registered to use the first network telephone 208a (which is identified by its telephone identifier), but move to a location near the second network telephone 208b. The user may re-register as the user of the second network telephone 208b. Calls that identify the user by the user's user identifier may reach the user at the second network telephone 208b.

## 2. Cable Network As An Exemplary Access Network

The system 200 in FIG. 2 also shows a cable network 214 connected to the data network 206 by a router 238. The cable network 214 provides data network access to its network elements, which in FIG. 2 include a third data network telephone 218a and a  
5 second network telephony connection server 162. The users of the data network telephone 218a connected to the cable network 214 may communicate over the data network 206 with the users of the data network telephones 208a-b connected to the local area network 212.

The cable network 214 includes any digital cable television system that provides  
10 data connectivity. In the cable network 214, data is communicated by radio frequency in a high-frequency coaxial cable. The cable network 214 may include a head-end, or a central termination system that permits management of the cable connections to the users.

## 3. Providing Telephony Services

The second network telephony connection server 162 is preferably a SIP-based  
15 server that performs call initiation, maintenance and teardown for the data network telephone 218a connected to the cable network 214. The second network telephony connection server 162 may be similar or identical to the first network telephony connection server 150 connected to the local area network 212.

The system 200 shown in FIG. 2 permits the data network telephones 208a-b  
20 connected to the local area network 212 to communicate with the data network telephone 218a connected to the cable network 214. The system shown in FIG. 2 uses SIP in order to establish, maintain, and teardown telephone calls between users.

There are two major architectural elements to SIP: the user agent (UA) and the network server. The UA resides at the SIP end stations, (e.g. the data network  
25 telephones), and contains two parts: a user agent client (UAC), which is responsible for issuing SIP requests, and a user agent server (UAS), which responds to such requests. There are three different network server types: a redirect server, a proxy server, and a registrar. The various network server types may be combined into a single server, such as the network telephony connection server 150 and 162. Not all server types are  
30 required to implement the embodiments of the present invention. The communication



services to be provided will determine which servers are present in the communication system. Preferred embodiments of the present invention may be carried out using proxy servers.

One example of a SIP operation involves a SIP UAC issuing a request, a SIP proxy server acting as end-user location discovery agent, and a SIP UAS accepting the call. A successful SIP invitation consists of two requests: INVITE followed by ACK. The INVITE message contains a user identifier to identify the callee, a caller user identifier to identify the caller, and a session description that informs the called party what type of media the caller can accept and where it wishes the media data to be sent. User identifiers in SIP requests are known as SIP addresses. SIP addresses are referred to as SIP Uniform Resource Locators (SIP-URLs), which are of the form *sip:user@host.domain*. Other addressing conventions may also be used.

Redirect servers process an INVITE message by sending back the SIP-URL where the callee is reachable. Proxy servers perform application layer routing of the SIP requests and responses. A proxy server can either be stateful or stateless. A stateful proxy holds information about the call during the entire time the call is up, while a stateless proxy processes a message without saving information contained in the message. Furthermore, proxies can be either forking or non-forking. A forking proxy can, for example, ring several data network telephones at once until somebody takes the call. Registrar servers are used to record the SIP address (the SIP URL) and the associated IP address. The most common use of a registrar server is for the UAC to notify the registrar where a particular SIP URL can be reached for a specified amount of time. When an INVITE request arrives for the SIP URL used in a REGISTER message, the proxy or redirect server forwards the request correctly.

At the local area network 212, the central registrar/proxy server, such as the first network telephony server 150, is the primary destination of all SIP messages trying to establish a connection with users on the local area network 212. Preferably, the first network telephony server 150 is also the only destination advertised to the SIP clients outside the LAN 212 on behalf of all the SIP clients residing on the LAN 212. The network telephony server 150 relays all SIP INVITE messages to the appropriate final

destination (or another SIP proxy), based on a database lookup using the first SIP database 152. It allows all mobile clients to register with their current locations.

Similarly, the second network telephony server 162 is the primary destination of all SIP messages trying to establish a connection with the data network telephone 218a  
5 connected to the cable network 214. Preferably, the second network telephony server 162 is also the only destination advertised to the SIP clients outside the cable network 214 on behalf of all the SIP clients (*e.g.* data network telephones) residing on the cable network 214. The second network telephony server 162 relays all SIP INVITE messages to the appropriate final destination (or another SIP proxy), based on a database lookup  
10 using the second SIP database 164.

The data network telephones 208a-b and 218a in the system 200 preferably have pre-programmed device identifiers (*e.g.* phone numbers), represented as SIP-URL's that are of the form *sip: user@domain*. An example is *sip: 8475551212@3Com.com..* After power-up, each of the data network telephones 208a-b and 218a sends a SIP REGISTER  
15 message to the default registrar, such as the network telephony servers 150 and 162. When a call arrives at one of the network telephony servers 150 or 162 for any of the registered SIP URLs, the server will forward the call to the appropriate destination. If a data network telephone is moved to a new location, all calls to the associated SIP URL will still be properly routed to that device. In other words, the system in FIG. 2 provides  
20 device mobility in the sense that calls will "follow" the data network telephone according to its SIP URL. This is especially useful if the data network telephone 208a-b or 218a is running the DHCP (Dynamic Host Configuration Protocol) so that when the location is changed, the IP address is also automatically changed.

An advantage of the system in FIG. 2 is that once the call is established between  
25 data network telephones, the data network 206 provides data connectivity for a plurality of data communications channels. For example, the data network telephones 208a and 218a can communicate voice signals as voice-over-data packets on a voice-over-data channel. The data network telephones 208a and 218a can also communicate data (such as PID data) as data packets on a data channel. For example, the data may be  
30 communicated to and from the PIDs 210a and/or 220a across links 209a and 219a to the data network telephones 208a and 218a, where data is packetized and depacketized as

part of the process for communicating the data packets across the data network 206 and any access networks, such as the Ethernet LAN 212 and the cable network 214. The data channels may be established to communicate data to and from the Internet services 101.

#### 4. The Data Network Telephones

5           The data network telephones 208a-b are preferably telephones that include an Ethernet communications interface for connection to an Ethernet port. The Ethernet phones in FIG. 2 support the Internet Protocol (IP), using an IP address that is either statically configured or obtained by access to a Dynamic Host Configuration Protocol (DHCP) server.

10           FIG. 3 is a block diagram showing the data network telephone 208a connected to the local area network 212 in FIG. 2. The data network telephone 208a in FIG. 3 is connected to the network 212 by a network interface 270. The network interface 270 may, for example, be a network interface card, and may be in the form of an integrated circuit. A bus 248 may be used to connect the network interface 270 with a processor  
15   240 and a memory 242. Also connected to the processor are user interface circuitry 260 and three alternative link interfaces to a PID, such as the PID 210a.

          A first link interface 248 includes an RS-232 serial connection and associated coupling hardware and mechanisms. The first alternative link interface 248 may, for example, be a docking cradle for a PDA (Personal Digital Assistant), in which  
20   information can be transferred between the PDA and the data network telephone 208a. The second alternative link interface comprises a first connection 254, such as an RS-232 connection, along with infrared circuitry 250 for converting signals into infrared output and for accepting infrared input. An infrared interface 252 may also be included within the second alternative link interface. The third alternative link interface comprises a first  
25   connection 256, such as an RS-232 connection, along with radio-frequency circuitry 258 for converting signals into radio frequency output and for accepting radio frequency input. A radio frequency interface 259 may also be included as part of the third alternative link interface.

          The three alternative link interfaces described above are merely examples, and  
30   additional means for implementing the link interface between the data network telephone

208a and the PID 210a may also be used. Although three link interfaces are shown in FIG. 3, there may be only one such interface in the data network telephone 208a. More than one link interface may be included to improve flexibility and to provide redundancy in case of failure of one of the link interfaces.

5           The user interface circuitry 260 includes hardware and software components that access the functions of the handset, display, and keypad to provide user input and output resources for functions in the processor 240. The user interface circuitry includes a display interface 262, a keypad interface 264, an audio output interface 265, and an audio input interface 267.

10           The audio input interface 267 may receive voice signals from a microphone or other audio input device and convert the signals to digital voice information. The conversion preferably conforms to the *G.711 ITU Standard*. Further processing of the digital signal may be performed in the audio input interface 267, such as providing compression (*e.g.* using G.723.1 standard) or providing noise reduction, although such  
15           processing may also be performed in the processor 240. Alternatively, the audio input interface 267 may communicate an analog voice signal to the processor 240 for conversion to digital information within the processor 240.

          The audio output interface 265 receives digital information representing voice from the processor 240 and converts the information to audible sound, such as through a  
20           magnetic speaker. In one embodiment, the audio output interface 265 receives information in the form of G.711, although other processing such as decompression may be performed in the audio output interface 265. Alternatively, the processor 240 may convert digital information to analog voice signals and communicate the analog voice signals to the audio output interface 265.

25           The keypad interface 264 and the display interface 262 include well-known device interfaces and respective signal processing techniques. The user interface circuitry 260 may support other hardware and software interfaces. For example, a videophone implementation might also include a camera and monitor. The data network telephones of the present invention are not limited to telephones or videophones – additional user  
30           interface types, for example, such as the ones needed for computer games, are also contemplated as being within the scope of the present invention. In addition, some of the

features described here, such as the display interface 262, are optional and serve to enhance the functionality of the first data network telephone 208a.

The processor 240 may consist of one or more smaller processing units, including, for example, a programmable digital signal processing engine. In the preferred  
5 embodiment, the processor is implemented as a single ASIC (Application Specific Integrated Circuit) to improve speed and to economize space. The processor 240 also may include an operating system, and application and communications software to implement the functions of the data network telephone 208a. The operating system may be any suitable commercially available embedded or disk-based operating system, or any  
10 proprietary operating system.

The processor 240 includes a media engine 241 and a signaling stack 243 to perform the primary communications and application functions of the data network telephone 208a. The purpose of the signaling stack in the exemplary data network telephone 208a is to set up, manage, and tear down a call. During the setup phase, a user  
15 may use the keypad to enter a user identifier to call. Alternatively, a PID such as PID 210a may transmit the user identifier of the party across the first link 209a. The signaling stack 243 receives the user entry and formats a request message to send to the user identified by the user identifier to initiate a telephone call. When the request message is sent, the location of the user identified by the user identifier is discovered,  
20 communication parameters, such as the supported voice CODEC types are exchanged, and a voice-over-data channel is established. During the management phase, for example, other parties may be invited to the call if needed. During the tear down phase, the call is terminated.

The signaling protocol used in the data network telephone 208a in FIG. 3 is the  
25 SIP protocol. In particular, the signaling stack implements a User Agent Client 244 and a User Agent Server 242, in accordance with the SIP protocol. Alternative signaling protocols, such as the ITU-T H.323 protocol, MGCP, MEGACO, and others, may also be used to implement the present invention.

Once the call is set up, the media engine 241 manages the communication over  
30 one or more data communications channels using network transport protocols and the network interface 270. The media engine 241 sends and receives data packets having a

data payload for carrying data and an indication of the type of data is being transported. The media engine 241 in the data network telephones 208a may sample the voice signals from the audio input 267 (or receive voice samples from the audio input 267), encode the samples, and build data packets on the sending side. On the receiver side, in addition to  
5 performing the reverse operations, the media engine also typically manages a receiver buffer to compensate for network jitter. Similar procedures may be performed for other types of data, such as graphical data, or for data used in PID applications such as email, contacts data, calendar data, other non-voice sound data, interactive game data, etc.

The media engine 241 may also include hardware and software components for  
10 performing registration functions 247, voice-over-data functions 249, display data functions 251, and keypad output functions 253. The media engine 241 processes data that is received from the network 212, and data to be sent over the network 241.

For data that is received from the network 212, the media engine 241 may determine from the type of data in the packet (such as by examining a packet header)  
15 whether packets contain sampled voice signals or other data types. Packets containing sampled voice signals are processed by the voice-over-data function 249. The voice-over-data function 249 preferably conforms to a protocol for formatting voice signals as digital data streams. While any suitable protocol may be used, the media (i.e. the voice signal) is preferably transported via the Real Time Protocol (RTP), which itself is carried  
20 inside of UDP (User Datagram Protocol). RTP is described in H. Schulzrinne et al., "RTP: A Transport Protocol for Real-Time Applications," IETF RFC 1889, Jan. 1996, which is incorporated herein by reference. UDP is described in J. Postel, "User Datagram Protocol," IETF RFC 768, Aug. 1980, and IP is described in J. Postel, ed., "Internet Protocol," IETF RFC 791, Sept. 1981, both of which are incorporated by  
25 reference herein.

Packets containing data for use in registering the data network telephone 208a with a network telephony service are processed by the registration function 247. By registering the data network telephone 208a, a user may establish with the network telephony connection server 150 that calls addressed to the user's user identifier may be  
30 connected to the data network telephone 208a. Registration may occur when the data network telephone 208a sends a request to register to a service provider host, such as the

network telephony connection server 150. The service provider host may respond by setting the user's user identifier to correspond to the telephone identifier of the data network telephone 208a, and by acknowledging the request with a status message to the data network telephone 208a. In one embodiment, a request to register the data network telephone 208a to a default user is automatically sent during power-up of the data network telephone 208a.

Other features may be added to the registration functions 247, or implemented as extensions to the registration functions 247. For example, the first data network telephone 208a may be provisioned to provide selected network telephony services by establishing a data connection with a service provider, requesting the selected services, and receiving data that ensures that the services have been successfully provisioned. Such services may include, for example, caller identification, call forwarding, voice mail and any other services offered by the network telephony service provider to enhance the capabilities of the first data network telephone 208a. One advantage of provisioning functions is that services may be ordered for temporary use in a manner convenient to the user.

Packets containing data for display on a display device of the data network telephone 208a are processed by the display data function 251. The display data function 251 may be used for displaying, for example, the names and user identifiers of other parties to the call, the status of the telephone call, billing information, and other information.

For data to be sent over the data network 212, the media engine 241 formats the data as data packets in accordance with a selected protocol. The selected protocol is preferably a protocol that is supported by data network telephones that will receive the data being transported. The media engine 241 may include a data connection application 245 to perform functions relating to data connections over the data network 206. The data network telephone 208 may include a data connection management protocol (e.g. the hypertext transport protocol, or http) to handle data connections. Alternatively, the SIP protocol may be used to establish data connections as well as voice connections. The data connection application 245 may also perform proxy services to permit the PID 108 to establish data connections.

The voice-over-data function 249 formats voice samples according to the protocol used by the receiving data network telephone. In one preferred embodiment, the voice over data function 249 formats voice samples as RTP packets. The registration function 247 and the keypad output function 253 may control the transport of data that does not  
5 represent voice signals.

The data network telephones 208b and 218a are preferably similar or identical to the data network telephone 208a. For each of the data network telephones 208a-b and 218a, many of the features described in FIG. 3 are optional and their inclusion depends on the services to be offered.

#### 10 5. The Portable Information Devices (PIDs)

FIG. 4 is a block diagram showing the exemplary PID 210a that can communicate via the link 209a with the data network telephone 208a connected to the LAN 212. The PID 210a may be linked to the data network telephone 208a through a link interface 545. A bus 580 may be used to connect the point-to-point interface 545 with a processor 540,  
15 a memory 542, data storage 543, and user interface circuitry 544.

The link interface 545 shown in FIG. 4 illustrates three alternative link interfaces for establishing a link to a data network telephone, such as the data network telephone 208a.

A first link interface 546 includes an RS-232 serial connection and associated  
20 coupling hardware mechanisms. The first alternative link interface 546 may, for example, be for coupling with a PDA docking cradle, in which information can be transferred between the PDA and the data network telephone 208a. The second alternative link interface comprises a first connection 548, such as an RS-232 serial connection, along with infrared circuitry 250 for converting signals into infrared output  
25 and for accepting infrared input. An infrared interface 552 may also be included within the second alternative link interface. The third alternative link interface comprises a first connection 554, such as an RS-232 connection, along with radio-frequency circuitry 556 for converting signals into radio frequency output and for accepting radio frequency  
input. A radio frequency interface 558 may also be included as part of the third



alternative interface. The radio interface 554/556/558 may be implemented according to the Bluetooth specifications, described at [www.bluetooth.com](http://www.bluetooth.com).

The three alternative link interfaces described above are merely exemplary, and additional means for implementing the interface between the PID 210a and the data network telephone 208a may also be utilized. Although three link interfaces are shown in FIG. 4, there may be only one such interface in the PID 210a. More than one link interface may be included to improve flexibility and to provide redundancy in case of failure of one of the link interfaces.

The user interface circuitry 544 includes hardware and software components that provide user input and output resources for functions in the processor 540. The user interface circuitry includes a display output 562, a display input 565, and an additional input/output interface 567.

The display output 562 preferably receives digital information representing graphical data from the processor 540 and converts the information to a graphical display, such as text and/or images, for display on a display screen, for example.

The display input 565 may receive data inputs, such as graphical data inputs, from a user of the PID 210a. The graphical data inputs are preferably entered by the user with a stylus on a pressure-sensitive display screen, and may include text, drawings, or other objects that are capable of being graphically presented.

The additional input/output interface 567 allows the user to enter other types of data besides graphical data into the PID 210a. For example, audio data, additional graphical data, or additional input, such as video camera input for example, may be entered through the additional input/output interface 567. The data may also include data formatted for operation with particular applications on the PID. For example, email data, calendar data, contacts data, database data, spreadsheets, notes, game data, etc. may also be entered. Touch-sensitive screen buttons are an exemplary method for a user to enter control data into the PID 210a.

The processor 540 may include an operating system, as well as application and communication software, to implement the functions of the PID 210a. The operating system may be any suitable commercially available operating system, or any proprietary operating system. The operating system and software may be stored on data storage 543,

in the memory 542, or the may be embedded in the processor 540. Although the processor 540 is shown connected to the data storage 543 through a bus 580, other configurations may also be used. Similarly, the memory 542 may be configured other than as shown in FIG. 4, and may be embedded within the processor 540.

5           The PID 210a is able to send data to and receive data from the data network telephone 208a across a point-to-point link, such as the point-to-point link 209a shown in FIG. 1. A user enters PID data at the display input 565. The graphical data may be processed in the user interface circuitry 544 or it may go directly to the processor 540 or the memory 542. The processor 540 may also perform processing functions, such as  
10           compression.

          A PID data application may be used to perform functions that may implement the display input, the display output, and the processing functions. For example, a web clippings application 575 may be used to request and receive information from Internet services 101 (shown in FIG. 2) in a format suitable for the PID 210. The information, or  
15           clippings are provided by the Internet services 101. The information retrieved as clippings could then be displayed through the display output 562 to enable the user to see a visual representation of the information.

          If the user desires to request information from web clippings 103, a periodic request may be set up to make a request at a designated time as long as a link interface to  
20           the data network telephone 208 is active. Alternatively, the user may store links (*e.g.* hot links) and select the hotlinks using the stylus or other user input to request specific information at anytime. The request can be transmitted through one of the point-to-point interfaces 545, allowing the data to be received by the data network telephone 208a. An application in the data network telephone 208a receives the request across the point-to-  
25           point link, and the request is prepared for transmission across the data network 206, such as by the media engine 241 shown in FIG. 3. Preferably the request is converted to data packets and is communicated on a data channel across the LAN 212 through the router 228 across the data network 206 to the selected web clipping 103.

          The web clipping 103 processes the request using well-known techniques (*e.g.*  
30           http). The requested information is formatted as data packets, preferably in the form of TCP/IP data packets to the data network telephone 208a. The data network telephone

208a may recognize the data packets as related to the previously made request and simply pass the information to the PID 210, or process the data packets.

The link 209a between PID 210a and the first data network telephone 208a can alternatively be implemented as an infrared link using all or parts of a specialized  
5 protocol, such as the Infrared Data Association (IrDA) protocol stack, where data is interpreted through the stack between application-layer processes at each end of the link.

FIG. 5 is a protocol diagram illustrating the layers of the IrDA protocol stack. An IrDA stack is implemented at each of the connection endpoints of an IrDA link. For example, the first PID 210a and the first data network telephone 208a could each  
10 implement an IrDA protocol stack to enable the link 209a. As a second alternative, two PIDs, such as the first PID 210a and the third PID 218a, may each contain an IrDA stack. In the second alternative, the communications between the PIDs and the data network telephones might take place without the assistance of IrDA. For example, IrDa data from the first PID 210a might be transmitted across the link 209a as a serial stream of data to  
15 the first data network telephone 208a, which might treat the IrDA data like any other data received from the first PID 210a. The first data network telephone 208a could then assemble the IrDA data into packets, such as TCP/IP packets for transport across the access and data networks to the third data network telephone 218a. The third data network telephone 218a may disassemble the packets and forward the IrDA data (without interpreting the IrDA portions) across the link 219a to the third PID 220a. The third PID  
20 220a could then process the IrDA information received across the networks.

The required layers of an IrDA protocol stack are the physical layer 602, the IrLAP layer 604, the IRLMP layer 606 and the IAS layer 608. The physical layer 602 specifies optical characteristics of the link, encoding of data, and framing for various  
25 speeds. The IrLAP (Link Access Protocol) layer 604 establishes the basic reliable connection between the two ends of the link. The IrLMP (Link Management Protocol) layer 606 multiplexes services and applications on the IrLAP connection. The IAS (Information Access Service) layer 608 provides a directory or "yellow pages" of services on an IrDA device.

30 The IrDA protocol also specifies a number of optional protocol layers, these protocol layers being TinyTP 610, IrOBEX 612, IrCOMM 614 and IrLAN 616. TinyTP

(Tiny Transport Protocol) 610 adds per-channel flow control to keep traffic over the IrDA link moving smoothly. This important function is required in many cases. IrOBEX (Infrared Object Exchange protocol) 612 provides for the easy transfer of files and other data objects between the IrDA devices at each end of the link. IrCOMM 614 is a serial and parallel port emulation that enables existing applications that use serial and parallel communications to use IrDA without change. IrLAN (Infrared Local Area Network) 616 enables walk-up infrared LAN access for laptops and other devices. The use of the optional layers depends upon the particular application in the IrDA device. The IrDA protocol stack is defined by such standards documents as "IrDA Serial Infrared Physical Layer Link Specification", "IrDA 'IrCOMM': Serial and Parallel Port Emulation over IR (Wire Replacement)", "IrDA Serial Infrared Link Access Protocol (IrLAP)", "IrDA Infrared Link Management Protocol (IrLMP)", and "IrDA 'Tiny TP': A Flow-Control Mechanism for use with IrLMP", and related specifications published by the IrDA and available at <http://www.irda.org/standards/specifications.asp> and is incorporated by reference herein.

The IrDA protocol stack can be implemented at just the PID devices at the endpoints with the intermediate phones and networks simply providing a tunnel for the media stream attendant to the infrared links. Since PIDs, such as the Palm PDA, already have an IrDA stack implemented in them to support their infrared link to other devices and the benefits of the IrDA stack are already available. By using the layers of the IrDA protocol stack, the PID applications and the base applications in the phones can be simplified as the IrDA protocol layers take over certain functionalities. For example, the IrOBEX layer in each IrDA protocol stack can be used to transfer text and graphics object files, such as electronic business cards or whiteboard graphics, end-to-end between PID devices connected via data connected data network telephones..

With the IrDA stack being implemented only in the PIDs and not in the phones, only a small level of delay is introduced for stack interpretation by each PID and the connection provided is largely transparent to the applications in the PID devices, i.e. little or no modification to existing user applications in the PIDs is required. This approach may be more suitable for delay sensitive applications, such as interactive games involving the transfer of data between user applications in each PID.

It should be noted that the IrDA stack is written for a single infrared point-to-point interface and not for an infrared-to-network-to-infrared interface. As a result, the timers and retransmission schemes implemented in view of the single infrared point-to-point interface may not function properly for the extended network interface.

5           Alternatively, IrDA stacks can be implemented in the phones as well. By implementing IrDA stacks in the phones, the timing of the infrared interface is unaffected by a network delay. Also, additional functions and features can be implemented in the phones. For example, the phones can implement challenge and authentication where the phone requires the user, through the PID, to enter a password or other information to  
10       authenticate an authorized user. Similarly, the PID may also be used to transmit commands to the phone and receive status information via the IrDA stack. The approach taken will depend upon the requirements of the design and the particular application.

#### 6. Providing Telephony and Access to Internet Services

FIG. 6 is a functional block diagram and protocol stack diagram illustrating an  
15       embodiment of the protocol stacks in the first PID 210a and the first data network telephone 208a that support link 209a. In the infrared RS-232 embodiment, the link interface circuitry 545 in the first PID 210a provides the physical layer 656, such as that specified by the Infrared Data Association (IrDA), that connects via link 209a to the link interface circuitry 260 implementing a physical layer 664 in the first data network  
20       telephone 208a. The data link layer 654 in the first PID 210a provides data link control for link 209a in transferring data to and from a PID application client 652. Similarly, the first data network telephone 208a includes a data link layer 662 and a base application server 600 that is configured to synchronize connection and other functions with the PID application 652 in the first PID 210a.

25           When PID 210a is activated, either through power-up or through a user input at the user interface 650, the synchronization application client 652 in the PID 210a may send the user's SIP URL across the link 209a to the first data network telephone 208a, where it is received by the synchronization application server 600. The synchronization application server 600 sends the SIP URL received from the PID 210a across connection  
30       230 and the Ethernet LAN 212 through connection 243 to the network telephony

connection server 150. The network telephony connection server 150 may store the SIP URL and the IP address of the associated data network telephone 208a in the SIP database 152 so that the SIP URL is listed as being resident at the IP address of the data network telephone 208a. (If the network telephony connection server 150 uses a location server for registration/location tasks, the registration information might instead be stored with such a location server). SQL (Structured Query Language) is preferred for querying the database. Once the PID 210a is registered with the network telephony connection server 150, calls to the SIP URL for PID 210a (or the user of the PID 210a) will be directed to the data network telephone 208a.

FIG. 7A is a functional block and protocol stack diagram illustrating an embodiment of the present invention where a SIP connection is established from the first data network phone 208a to the third data network phone 218a through network connection 230, first access network 212, data network 206, second access network 214 and network connection 236. The routers 228 and 238, and associated connections 232a-b and 234a-b, are not shown to simplify the block diagram representation.

The diagram of FIG. 7A shows how requests for Internet services can be transmitted and responses to the requests processed in one aspect of the present invention. The PID application 652 in PID 210a is configured to send PID data as input, which in the present context is a request for data, such as a hotlink, or an URL. The request is sent through the user interface 650 through link 209a to base application 660 in the first data network phone 208a. In this embodiment, base application 660 is configured to define data channels for transport to the Internet services 101. The Internet services 101 responds to the request by sending back requested services to the PID 110a. For example, the Internet services may send back data from web clippings 686 to the PID 110a as PID data.

Multiple data channels in SIP may be defined through the Session Description Protocol described in RFC 2327, herein incorporated by reference. Included in a SIP INVITE request for a connection are options for the requested connection that describe the number and type of media streams. Each media stream is described by a "m=" line in the INVITE request. For example, a request for a connection that includes an audio stream and a bidirectional video stream using H.261 might look like this:

v=0  
o=alice 2890844526 2890844526 IN IP4 host.anywhere.com  
c=IN IP4 host.anywhere.com  
5 m=audio 49170 RTP/AVP 0  
a=rtpmap:0 PCMU/8000  
m=video 51372 RTP/AVP 31  
a=rtpmap:31 H261/90000

TABLE 1.

10

If the called device includes functionality to receive the connection as described in Table 1, then the called device will respond to the INVITE request with a 200 OK response that includes the same option values. If the called device or party is unable or unwilling to receive such a connection, then it will respond with alternative option values  
15 for the connection. See RFC 2543 for further details regarding the negotiation of connection parameters in SIP.

In FIG. 7A, a first data channel for voice data has been negotiated by the base applications 660 in the first data network telephone 208a and the base application 674 in the second data network telephone 218a. In addition, a second data channel for Internet  
20 services data has been negotiated by the base application 660 in the first data network telephone 208a and web clippings application 686 in the Internet services 101.

The base applications 660 and 674 transfer voice data between the AUDIO applications, such as applications including G.711 encoders, in each phone via the first data channel. The base application 660 in phone 208a is also configured to send data  
25 requests received via link 209a from PID 210a to the Internet services 101 via the second data channel. The Internet services 101 processes the request and provides the requested information over the second data channel.

One advantage of the embodiment in FIG. 7A is that the voice channel is optional. The users may request the data connection to the Internet services 101 while conversing  
30 on the phones 208. Alternatively, a user may connect to the Internet services 101 independent of any voice connection.

FIG. 7B shows an alternative embodiment for providing a data connection from the PID 110a to the Internet services 101. The link 209a in FIG. 7B is an RS232 connection. The PID 110a includes an IP stack that includes a Point-To-Point client 653. In addition, the telephone 208a includes a PPP server 663. The PID 110a may connect  
5 directly to the Internet services 101 with its own IP address. One advantage of using the PPP-based connection in FIG. 7B is that even a basic, low-cost PID 110a may perform sophisticated Internet communications because the PPP is widely available at a low cost.

### C. Accessing Internet Services Concurrent with Voice Services

FIG. 8 shows an exemplary embodiment of the present invention for transmitting  
10 data from an Internet service concurrently with voice services during a telephone conversation. The PID 210a includes a display screen 702, a stylus 700 that a user can use to select a hotlink, or URL address to a Web service. Alternatively, a SYNC button 718 may be used to initiate a series of requests to the Internet services 101.

The display screen 702 is shown as a pressure-sensitive display screen in which  
15 the stylus 700 can be used to enter PID data 714 into the first PID 210a. In the example shown in FIG. 8, the PID 210a includes hotlink 706 for accessing prices of selected stocks from the Internet services 101. The stylus is being used to select the hotlink 706 the stock prices.

In the embodiment shown in FIG. 8, the hotlink 706 is transmitted across the link  
20 209a to the first data network telephone 208a. When the first data network telephone 208a receives the transmitted hotlink 714, an application within the first data network telephone 208a will place the hotlink 714 into PID data packets for transmission to the Internet services 101 across the access and data networks 212, 206 (and any associated connections and routers). The Internet services then processes the hotlink 714 and  
25 responds by sending the requested stock prices in the PID data channel 724 back to the data network telephone 208. The data network telephone 208 transmits the information to the PID 208 for display on the PID display 702.

While the invention has been described in conjunction with presently preferred  
30 embodiments of the invention, persons of skill in the art will appreciate that variations may be made without departure from the scope and spirit of the invention. For example,



the access networks shown in FIG. 2 may comprise any other suitable type of local area network or service infrastructure.

In addition, protocols of various types are referenced throughout. While preferred and alternative embodiments may implement selected protocols, any suitable replacement  
5 protocol not mentioned, or any function not part of a protocol used to replace a corresponding function from a protocol may be implemented without departing from the scope of the invention.

This true scope and spirit is defined by the appended claims, interpreted in light of the foregoing.

**WE CLAIM:**

1. A system for accessing Internet services on a data network telephony system comprising:
  - a data network to provide data connectivity for a plurality of data communications channels using data transport protocols;
  - 5 at least one Internet service connected to the data network;
  - a data network telephone connected to the data network, the data network telephone operable to communicate a voice signal as voice-over-data packets on a voice-over-data channel, the voice over data channel being one of the plurality of data communications channels on the data network, the data network telephone operable to
  - 10 convert voice-over-data packets communicated on the voice-over-data channel to voice signals; and
  - a portable information device comprising a first graphical user interface and a first data network telephone interface, the first graphical user interface operable to accept and display information from the Internet service, the first data network telephone interface
  - 15 operable to communicate at least one request for Internet services to and from the first data network telephone.

FIG. 1

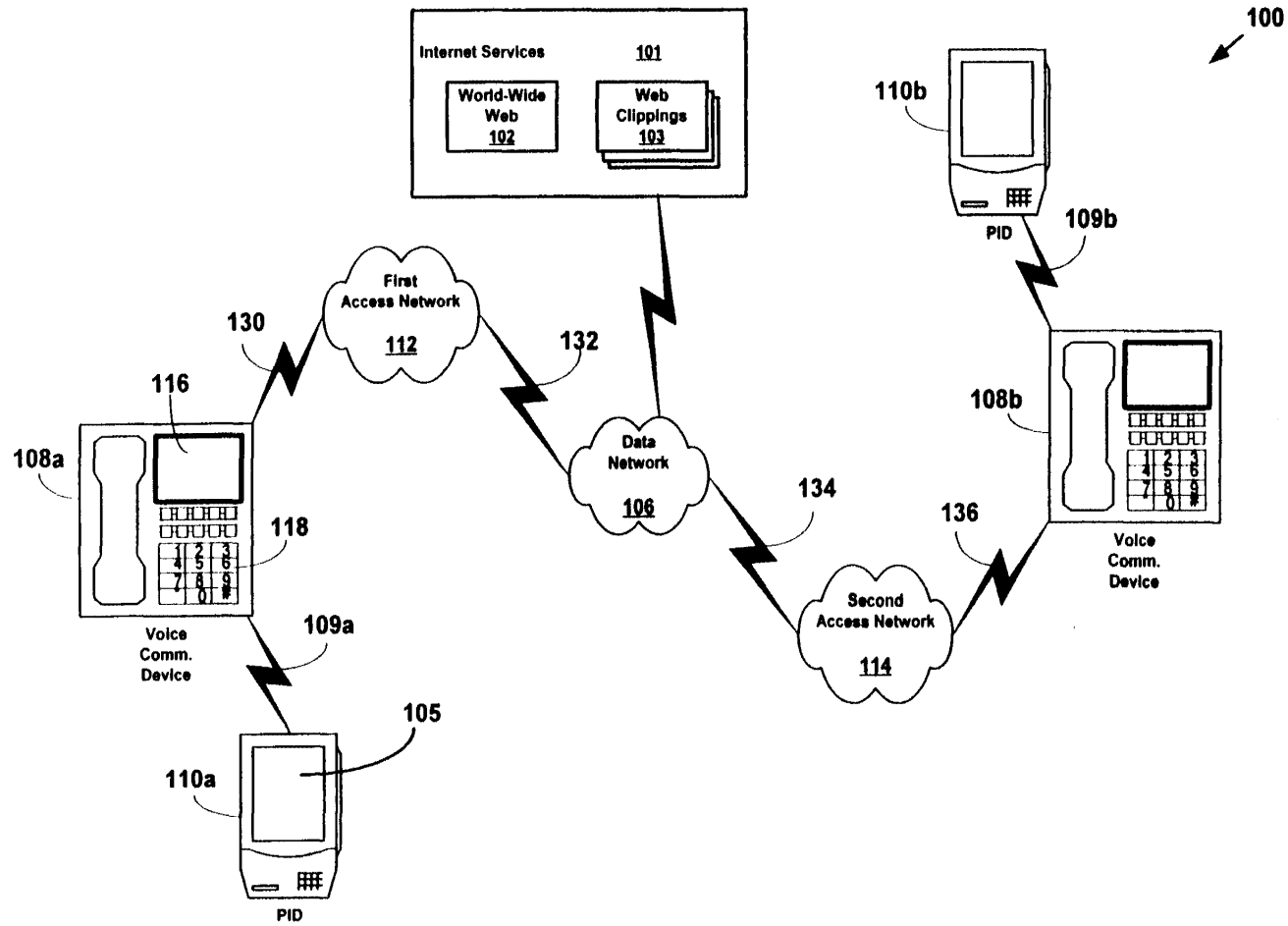
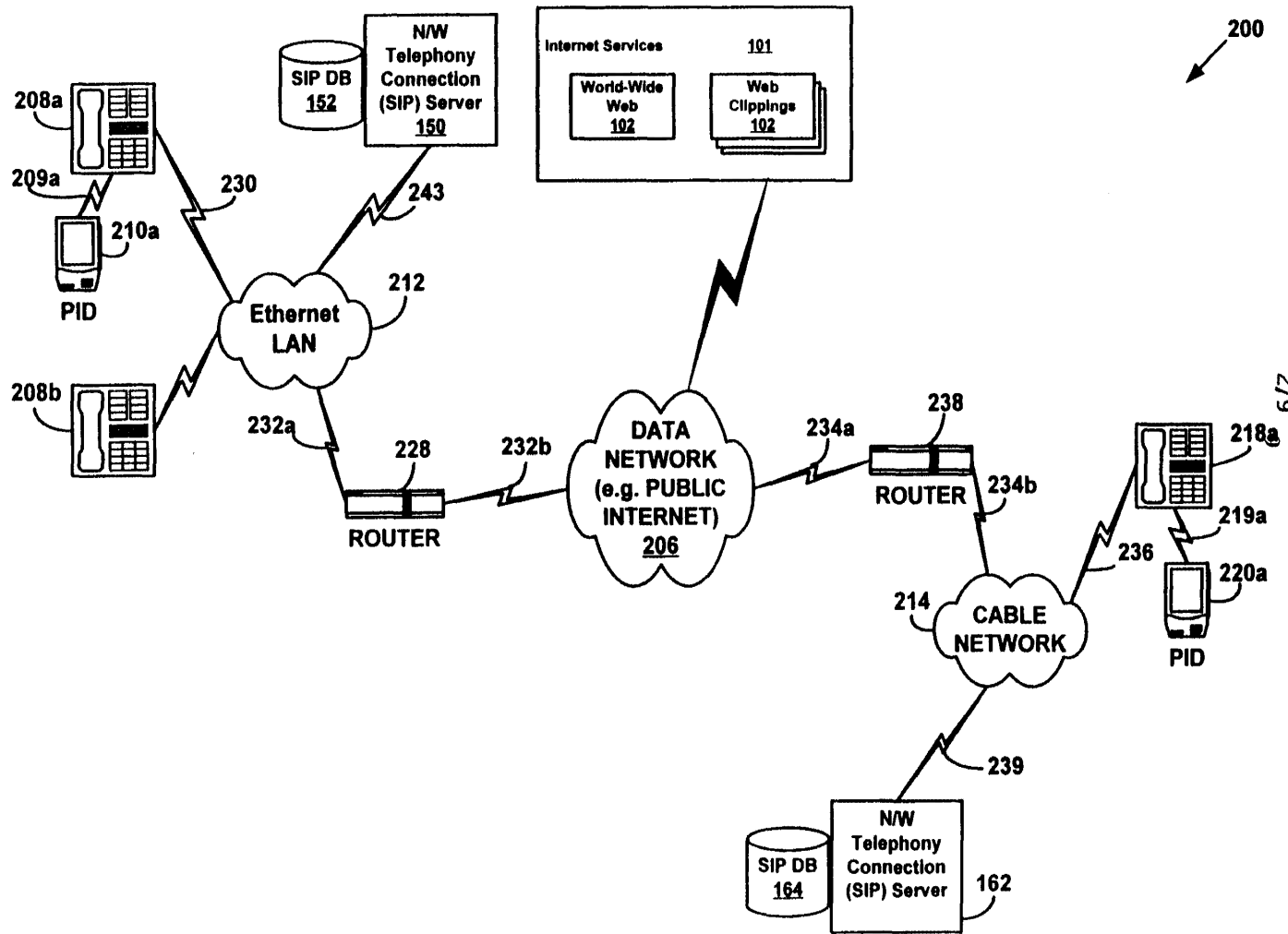


FIG. 2

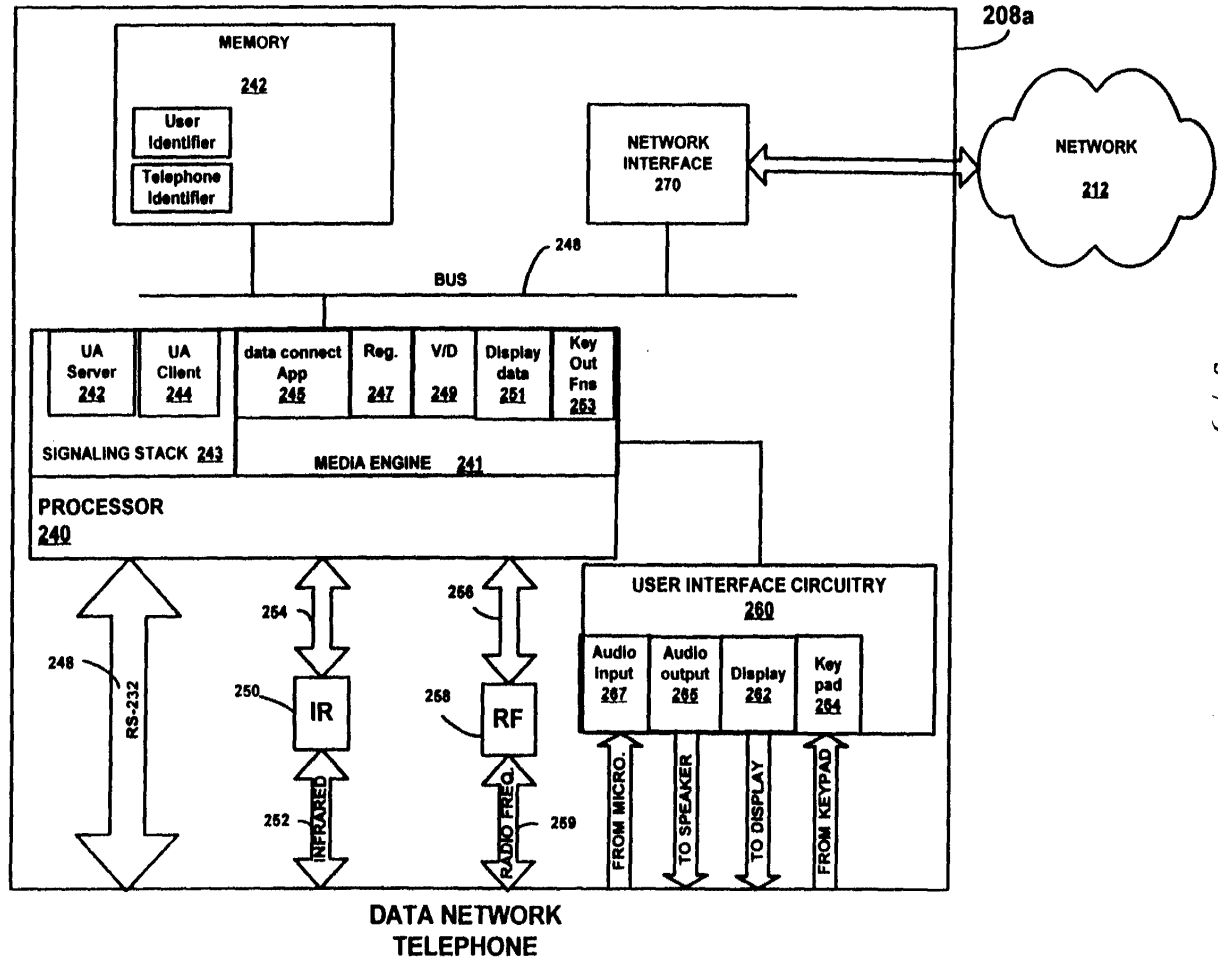


WO 01/24500

2/9

PCT/US00/26594

**FIG. 3**

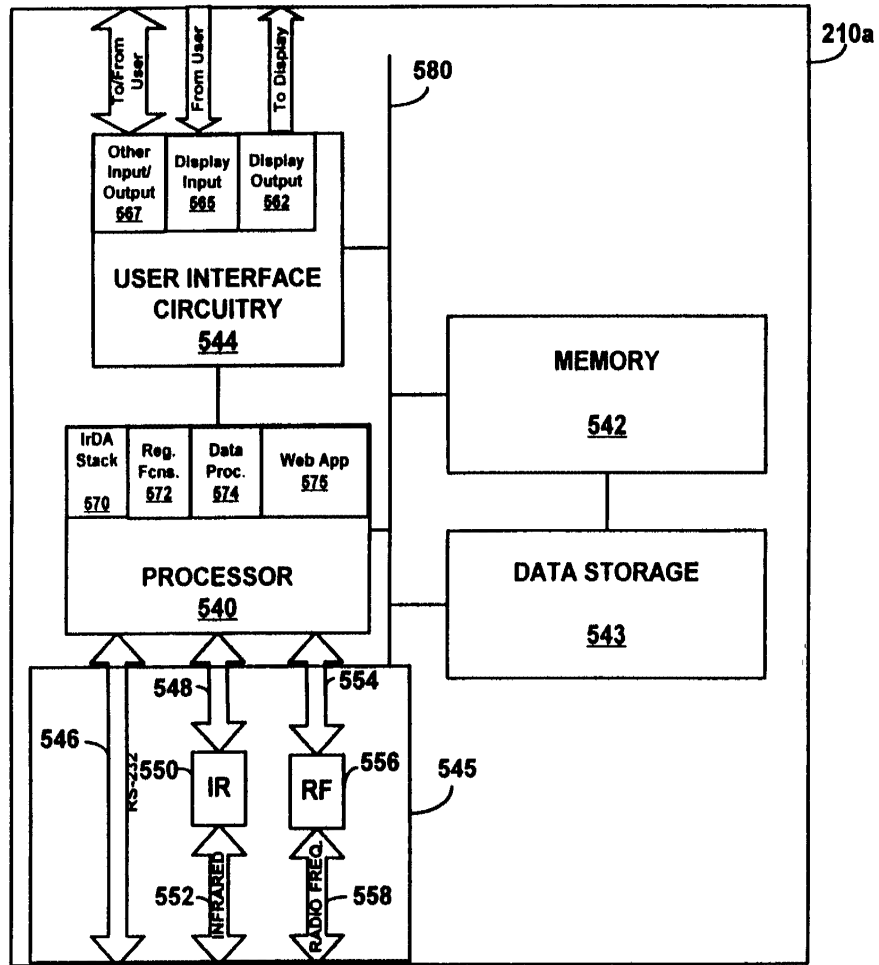


WO 01/24500

3 / 9

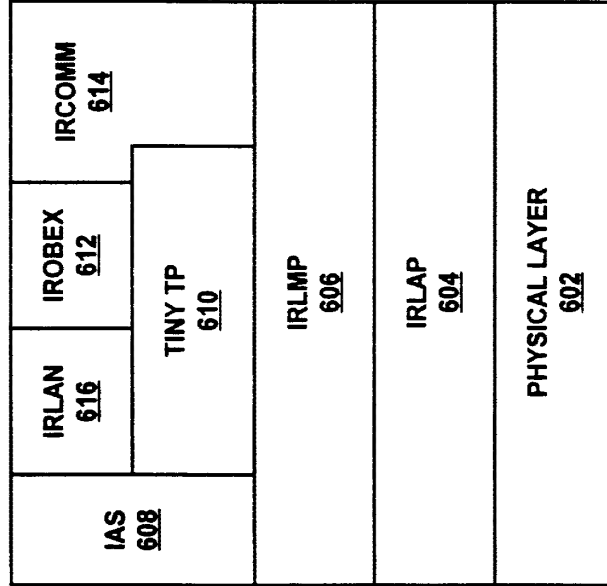
PCT/US00/26594

**FIG. 4**



PID

600 ↗



**FIG. 5**

FIG. 6

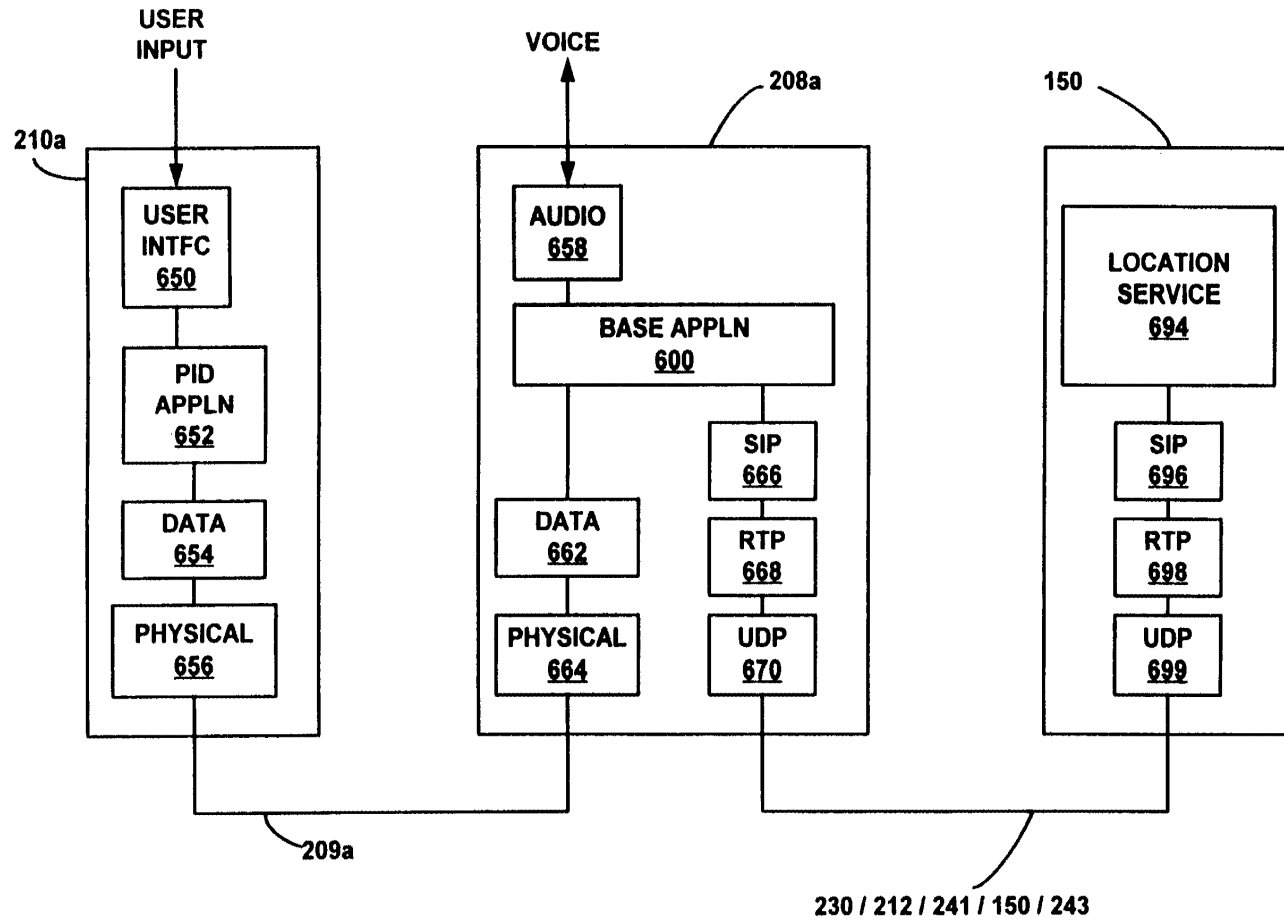




FIG. 7A

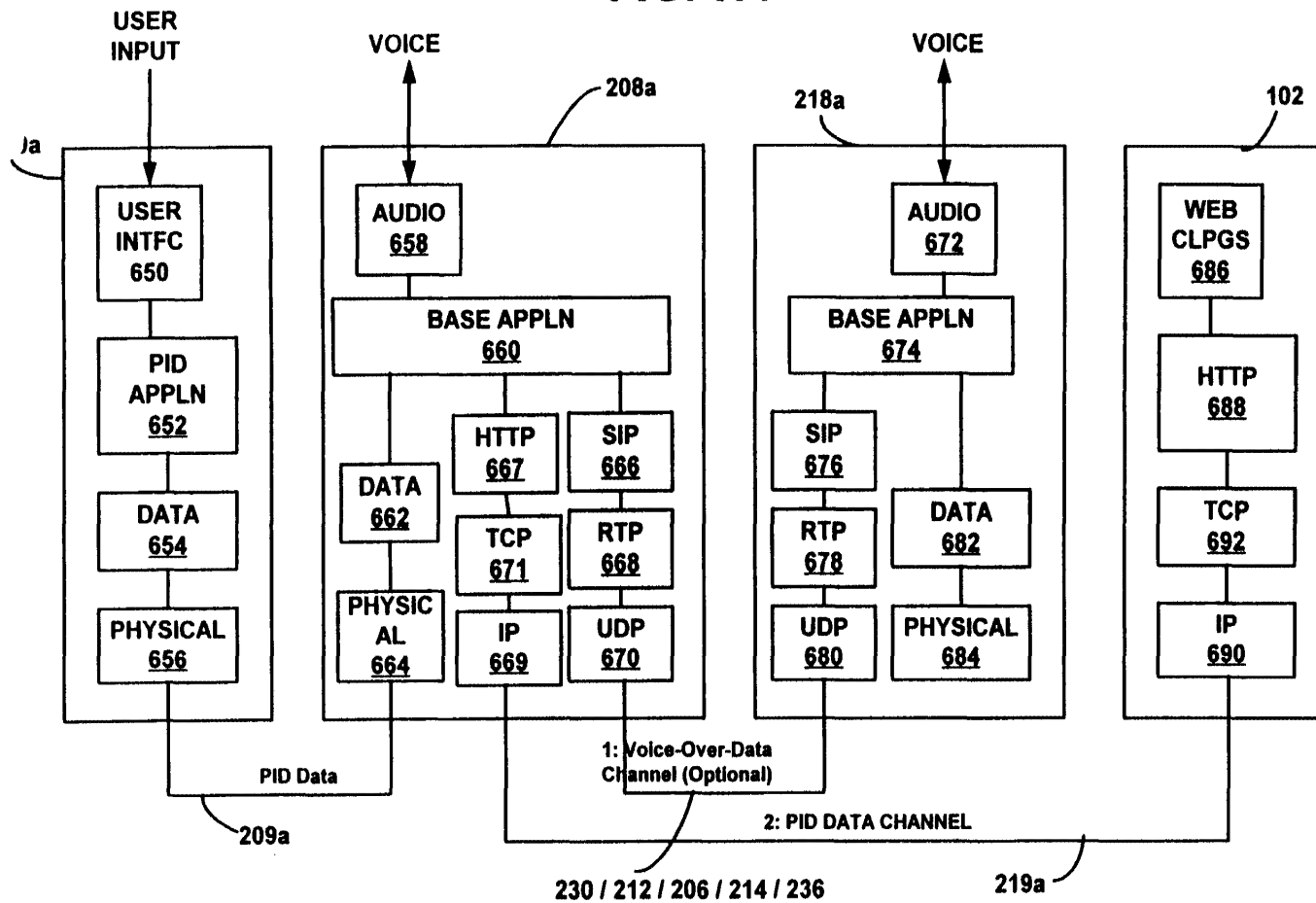
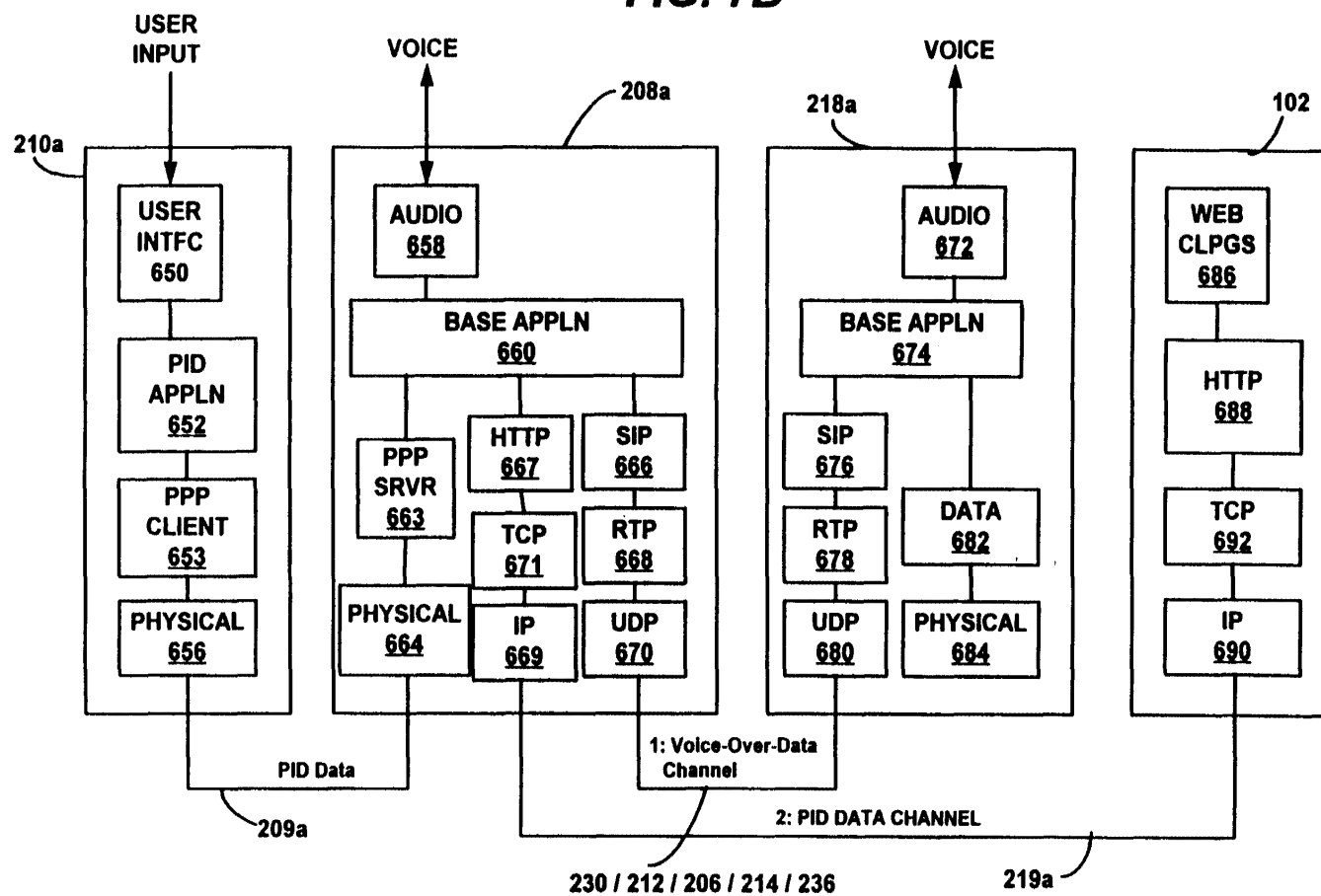
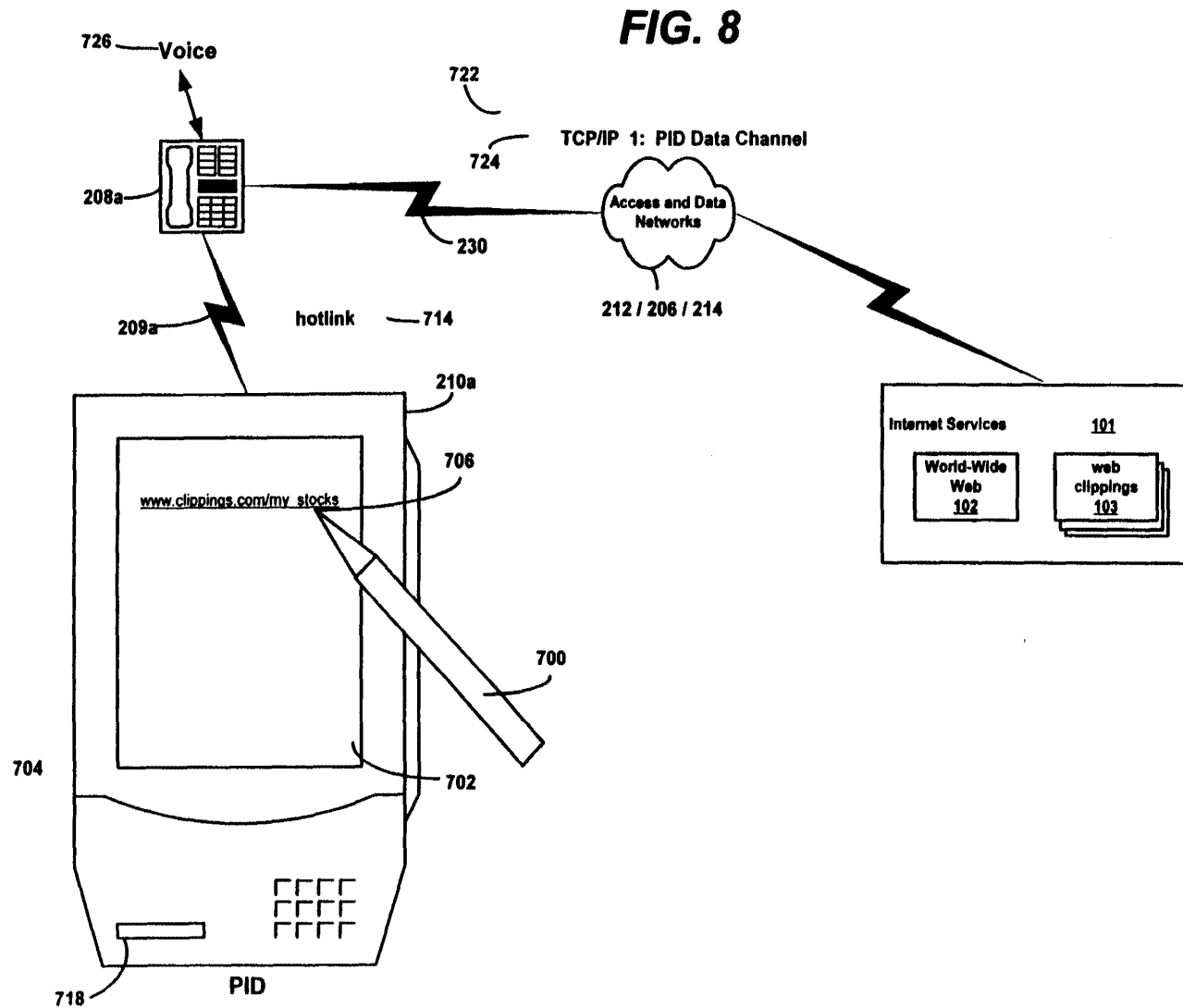


FIG. 7B





**FIG. 8**

# INTERNATIONAL SEARCH REPORT

International Application No  
PCT/US 00/26594

<b>A. CLASSIFICATION OF SUBJECT MATTER</b> IPC 7 H04M7/00		
According to International Patent Classification (IPC) or to both national classification and IPC		
<b>B. FIELDS SEARCHED</b> Minimum documentation searched (classification system followed by classification symbols) IPC 7 H04M		
Documentation searched other than minimum documentation to the extent that such documents are included in the fields searched		
Electronic data base consulted during the international search (name of data base and, where practical, search terms used) EPO-Internal, WPI Data, PAJ, INSPEC, COMPENDEX, IBM-TDB		
<b>C. DOCUMENTS CONSIDERED TO BE RELEVANT</b>		
Category °	Citation of document, with indication, where appropriate, of the relevant passages	Relevant to claim No.
X	DALGIC I ET AL: "TRUE NUMBER PORTABILITY AND ADVANCED CALL SCREENING IN A SIP-BASED IP TELEPHONY SYSTEM" IEEE COMMUNICATIONS MAGAZINE, IEEE SERVICE CENTER, PISCATAWAY, N.J,US, vol. 37, no. 7, July 1999 (1999-07), pages 96-101, XP000835310 ISSN: 0163-6804 the whole document	1
X	WO 99 19988 A (INFOGEAR TECHNOLOGY CORP) 22 April 1999 (1999-04-22) abstract page 19, line 1 - line 7	1
--- -/-- ---		
<input checked="" type="checkbox"/> Further documents are listed in the continuation of box C.		
<input checked="" type="checkbox"/> Patent family members are listed in annex.		
° Special categories of cited documents :		
*A* document defining the general state of the art which is not considered to be of particular relevance	*T* later document published after the international filing date or priority date and not in conflict with the application but cited to understand the principle or theory underlying the invention	
*E* earlier document but published on or after the international filing date	*X* document of particular relevance; the claimed invention cannot be considered novel or cannot be considered to involve an inventive step when the document is taken alone	
*L* document which may throw doubts on priority claim(s) or which is cited to establish the publication date of another citation or other special reason (as specified)	*Y* document of particular relevance; the claimed invention cannot be considered to involve an inventive step when the document is combined with one or more other such documents, such combination being obvious to a person skilled in the art.	
*O* document referring to an oral disclosure, use, exhibition or other means	*&* document member of the same patent family	
*P* document published prior to the international filing date but later than the priority date claimed		
Date of the actual completion of the international search  <p style="text-align: center;">24 January 2001</p>	Date of mailing of the international search report  <p style="text-align: center;">06/02/2001</p>	
Name and mailing address of the ISA European Patent Office, P.B. 5818 Patentlaan 2 NL - 2280 HV Rijswijk Tel. (+31-70) 340-2040, Tx. 31 651 epo nl, Fax: (+31-70) 340-3016	Authorized officer  <p style="text-align: center;">Megalou, M</p>	

Form PCT/ISA/210 (second sheet) (July 1992)

INTERNATIONAL SEARCH REPORT

International Application No  
PCT/US 00/26594

C.(Continuation) DOCUMENTS CONSIDERED TO BE RELEVANT		
Category °	Citation of document, with indication, where appropriate, of the relevant passages	Relevant to claim No.
X	<p>WATANABE H ; SASAKI N ; TANIGAWA K ; KANAMORI Y : "Development of the BTRON-BrainPad" PROCEEDINGS 13TH TRON PROJECT INTERNATIONAL SYMPOSIUM , 'Online! 4 - 7 December 1996, pages 95-103, XP002158413 Tokyo, Japan page 98, paragraph 3.2 -----</p>	1
A	<p>GESSLER S ET AL: "PDAs as mobile WWW browsers" COMPUTER NETWORKS AND ISDN SYSTEMS,NL,NORTH HOLLAND PUBLISHING. AMSTERDAM, vol. 28, no. 1, 1 December 1995 (1995-12-01), pages 53-59, XP004001210 ISSN: 0169-7552 page 55, paragraph 3.1 -----</p>	1

# INTERNATIONAL SEARCH REPORT

Information on patent family members

International Application No

PCT/US 00/26594

Patent document cited in search report	Publication date	Patent family member(s)	Publication date
WO 9919988 A	22-04-1999	AU 9570598 A	03-05-1999
		EP 1021902 A	26-07-2000
		ZA 9808251 A	13-05-1999
-----			

Form PCT/ISA/210 (patent family annex) (July 1992)