

- [54] METHOD AND APPARATUS FOR MULTIPLEXING CIRCUIT AND PACKET TRAFFIC
- [75] Inventors: Hung-Hsiang J. Chao, Madison; Sang H. Lee, Bridgewater; Liang T. Wu, Gladstone, all of N.J.
- [73] Assignee: Bell Communications Research, Inc., Livingston, N.J.
- [21] Appl. No.: 118,977
- [22] Filed: Nov. 10, 1987
- [51] Int. Cl.⁴ H04J 3/16; H04J 3/26
- [52] U.S. Cl. 370/94.2; 370/84; 370/99; 370/112
- [58] Field of Search 370/94, 60, 84, 99, 370/111, 112, 82, 110.1, 89

Technology", Proc. 1986, International Zurich Seminar on Digital Communications, pp. 136-138.
 W. W. Chu, "A Study of Asynchronous Time Division Multiplexing for Time Sharing Computer Systems", Proc. AFIPS, vol. 35, pp. 669-678, 1969.
 A. Thomas, et al., "Asynchronous Time Division Techniques: An Experimental Packet Network Integrating Video Communication", Proc. International Switching Symposium, May 1984.

Primary Examiner—Douglas W. Olms
 Assistant Examiner—Min Jung
 Attorney, Agent, or Firm—James W. Falk

[56] References Cited

U.S. PATENT DOCUMENTS

4,321,703	3/1982	Schwäertz et al.	370/89
4,516,240	5/1985	Kume et al.	370/94
4,594,708	6/1986	Servel et al.	370/94
4,685,105	8/1987	Shikama et al.	370/89
4,706,246	11/1987	Kume	370/89
4,763,319	8/1988	Rozenblit	370/89
4,764,921	8/1988	Graves et al.	370/110.1
4,771,425	9/1988	Baran et al.	370/110.1

OTHER PUBLICATIONS

R. W. Muise, et al., "Experiments in Wideband Packet

[57] ABSTRACT

A data transmission technique referred to herein as Dynamic Time Division Multiplexing (DTDM) is disclosed along with a set of multiplexers and demultiplexers required to apply DTDM in an actual telecommunications network. The DTDM technique uses a transmission format which is compatible with the existing digital circuit transmission format and the packet transmission format so that DTDM is able to handle the transmission of circuit and packet traffic. Thus, DTDM provides a flexible migration strategy between present circuit networks and future broadband packet networks.

7 Claims, 10 Drawing Sheets

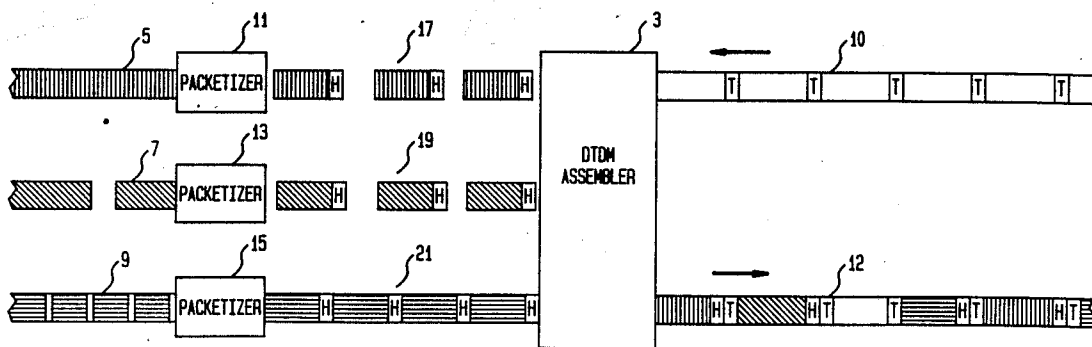

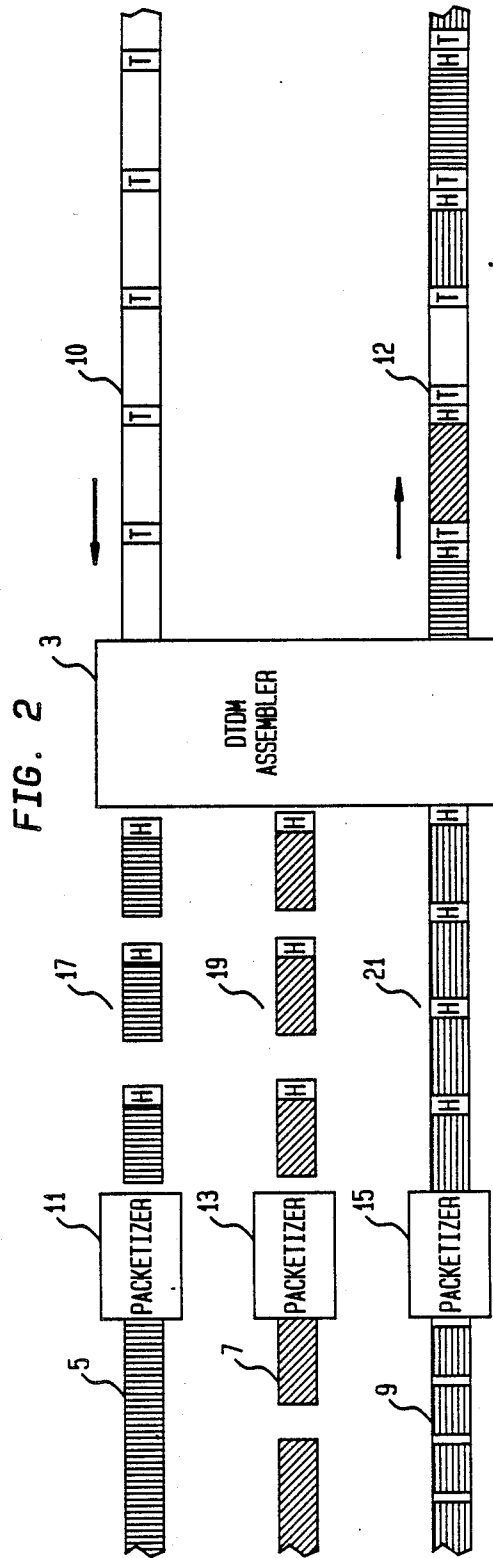
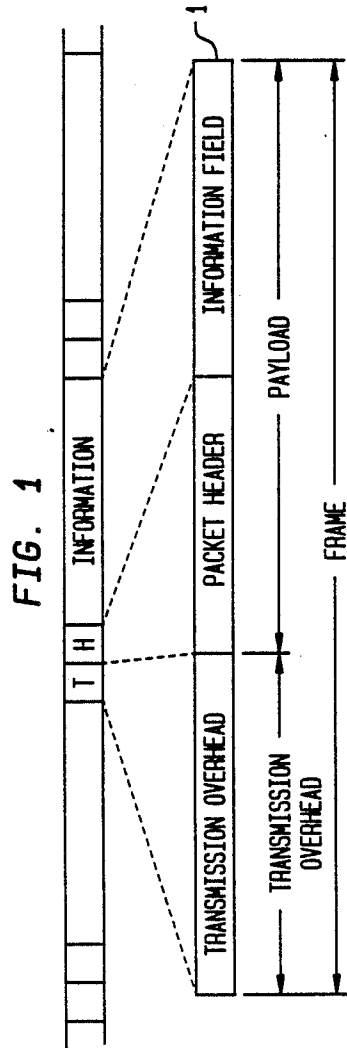
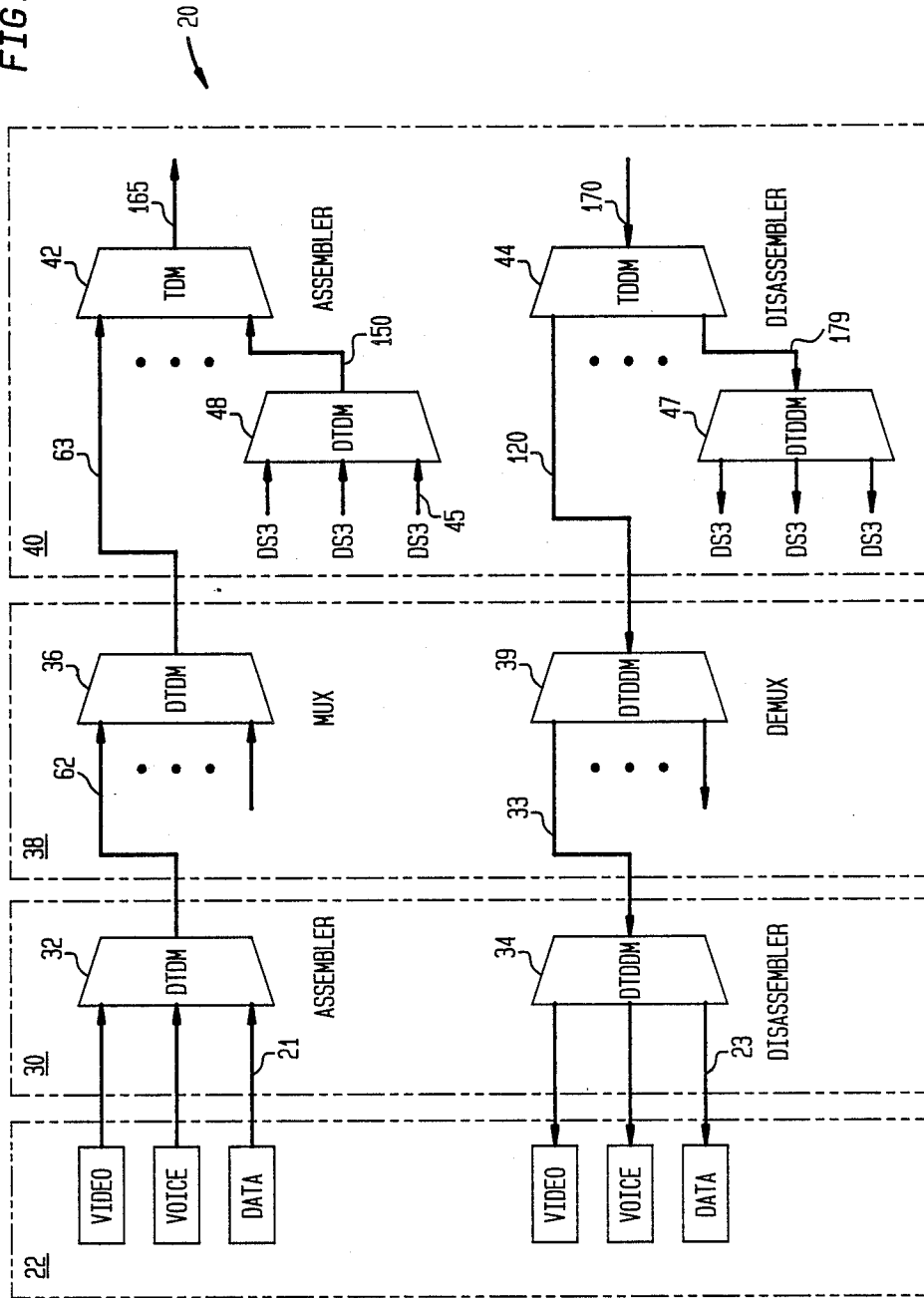

FIG. 3



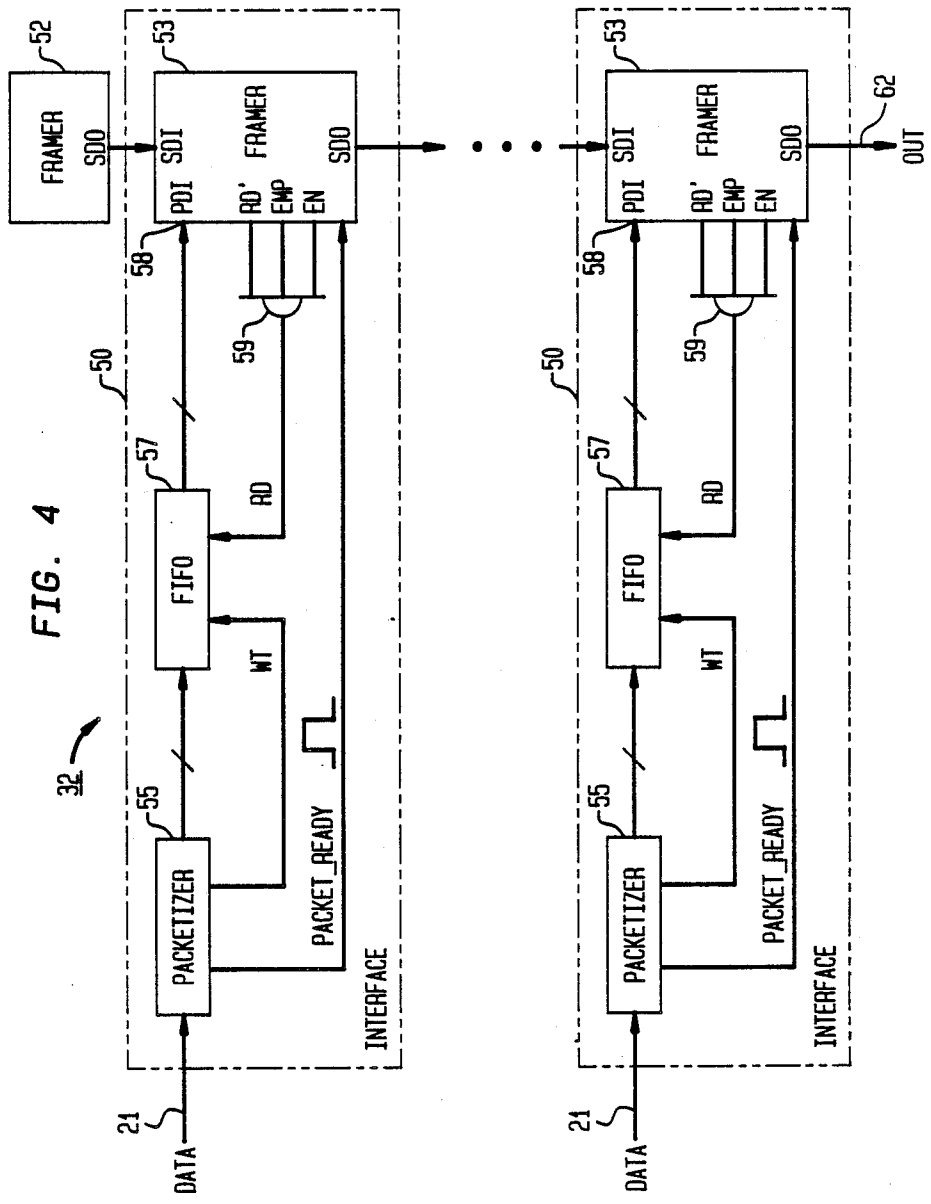
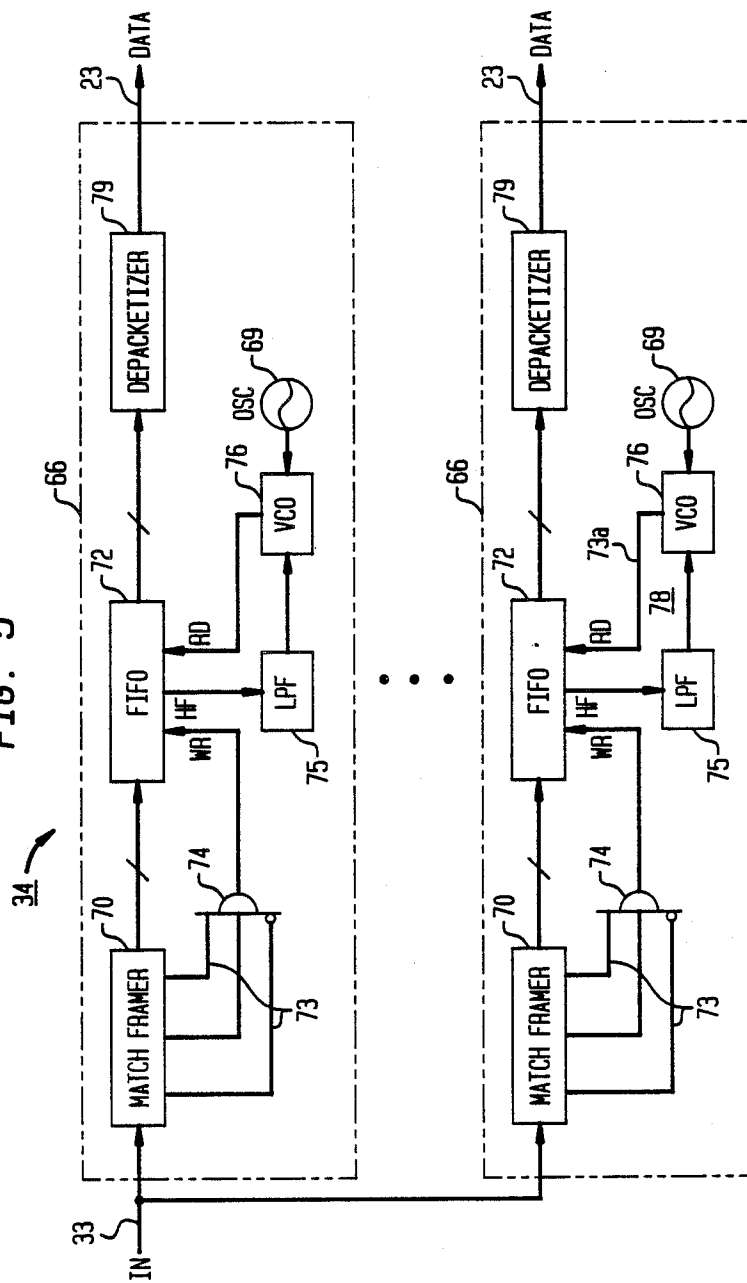

FIG. 5



Explore Litigation Insights

Docket Alarm provides insights to develop a more informed litigation strategy and the peace of mind of knowing you're on top of things.

Real-Time Litigation Alerts



Keep your litigation team up-to-date with **real-time alerts** and advanced team management tools built for the enterprise, all while greatly reducing PACER spend.

Our comprehensive service means we can handle Federal, State, and Administrative courts across the country.

Advanced Docket Research



With over 230 million records, Docket Alarm's cloud-native docket research platform finds what other services can't. Coverage includes Federal, State, plus PTAB, TTAB, ITC and NLRB decisions, all in one place.

Identify arguments that have been successful in the past with full text, pinpoint searching. Link to case law cited within any court document via Fastcase.

Analytics At Your Fingertips



Learn what happened the last time a particular judge, opposing counsel or company faced cases similar to yours.

Advanced out-of-the-box PTAB and TTAB analytics are always at your fingertips.

API

Docket Alarm offers a powerful API (application programming interface) to developers that want to integrate case filings into their apps.

LAW FIRMS

Build custom dashboards for your attorneys and clients with live data direct from the court.

Automate many repetitive legal tasks like conflict checks, document management, and marketing.

FINANCIAL INSTITUTIONS

Litigation and bankruptcy checks for companies and debtors.

E-DISCOVERY AND LEGAL VENDORS

Sync your system to PACER to automate legal marketing.