



US005858873A

United States Patent [19]

[11] **Patent Number:** **5,858,873**

Vitkavage et al.

[45] **Date of Patent:** **Jan. 12, 1999**

[54] **INTEGRATED CIRCUIT HAVING AMORPHOUS SILICIDE LAYER IN CONTACTS AND VIAS AND METHOD OF MANUFACTURE THEREOF**

5,420,074	5/1995	Ohshima	438/630
5,451,545	9/1995	Ramawami et al.	437/200
5,451,551	9/1995	Krishnan et al.	438/627
5,504,038	4/1996	Chien et al.	437/192
5,514,908	5/1996	Liao et al.	257/751
5,529,955	6/1996	Hibino et al.	438/626
5,585,308	12/1996	Sardella	438/629
5,591,671	1/1997	Kim et al.	438/630

[75] Inventors: **Susan C. Vitkavage; Daniel J. Vitkavage; Sailesh M. Merchant**, all of Orlando, Fla.

OTHER PUBLICATIONS

[73] Assignee: **Lucent Technologies Inc.**, Murry Hill, N.J.

Wolf, Stanley "Silicon Processing for the VLSI Era vol. 1: Process Technology", Lattice Press, pp. 331-335,384-392, 1986.

[21] Appl. No.: **816,185**

Primary Examiner—John F. Niebling
Assistant Examiner—Michael S. Lebentritt

[22] Filed: **Mar. 12, 1997**

[51] Int. Cl.⁶ **H01L 21/4763**

[57] ABSTRACT

[52] U.S. Cl. **438/626; 438/628**

[58] Field of Search 438/626-631

An integrated circuit, a contact and a method of manufacture therefor. The integrated circuit has a silicon substrate with a recess formed therein that provides an environment within which the contact is formed. The contact includes: (1) an adhesion layer deposited on an inner surface of the recess, (2) an amorphous layer, deposited over the adhesion layer within the recess and (3) a central plug, composed of a conductive material, deposited at least partially within the recess, the silicide layer being amorphous to prevent the conductive material from passing through the amorphous silicide layer to contact the adhesion layer thereby to prevent junction leakage.

[56] References Cited

U.S. PATENT DOCUMENTS

4,800,176	1/1989	Kakumu et al.	438/626
4,957,777	9/1990	Iderem et al.	437/55
4,960,732	10/1990	Dixit et al.	438/629
4,962,414	10/1990	Liou et al.	438/625
4,976,839	12/1990	Inoue	204/192.17
5,106,781	4/1992	Penning De Vries	438/631
5,332,691	7/1994	Kinoshita et al.	438/629
5,371,041	12/1994	Liou et al.	437/192
5,380,678	1/1995	Yu et al.	438/627
5,397,742	3/1995	Kim	438/630

7 Claims, 2 Drawing Sheets

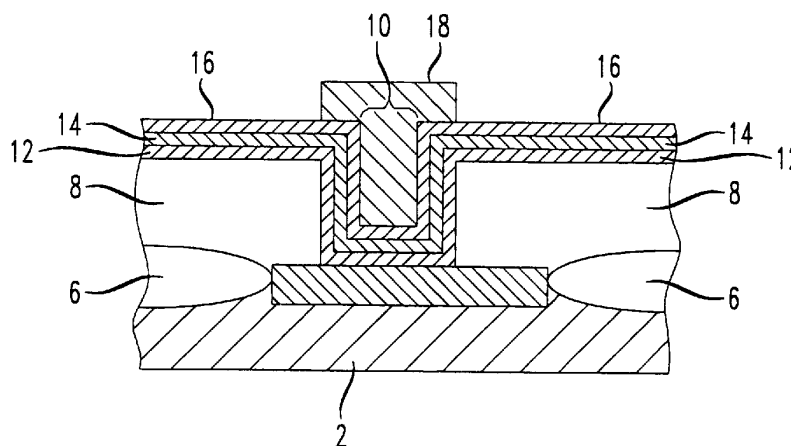

FIG. 1

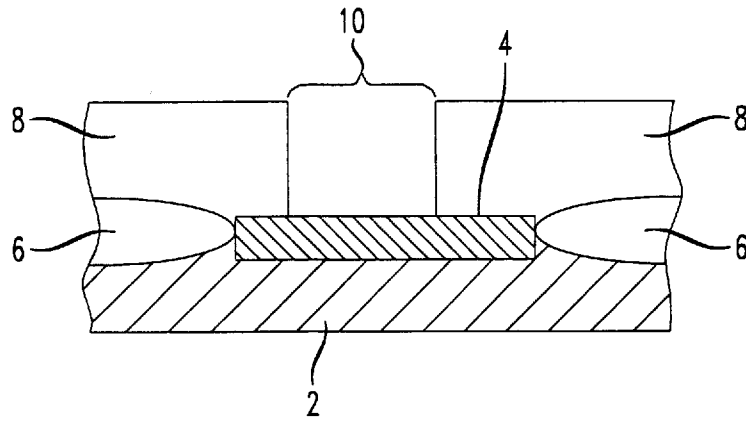

FIG. 2

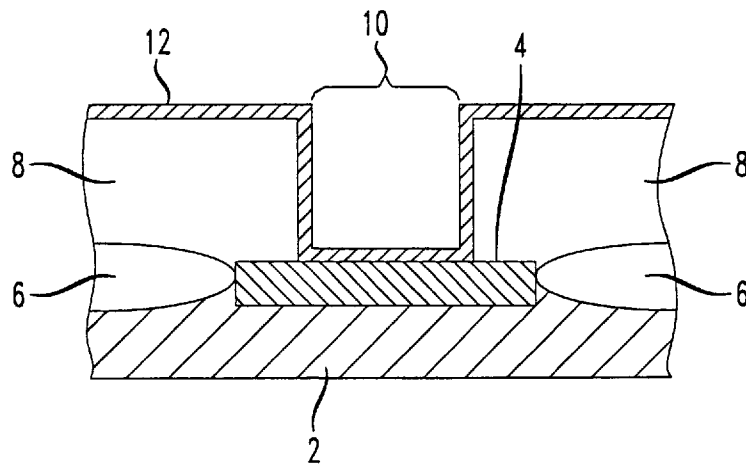

FIG. 3

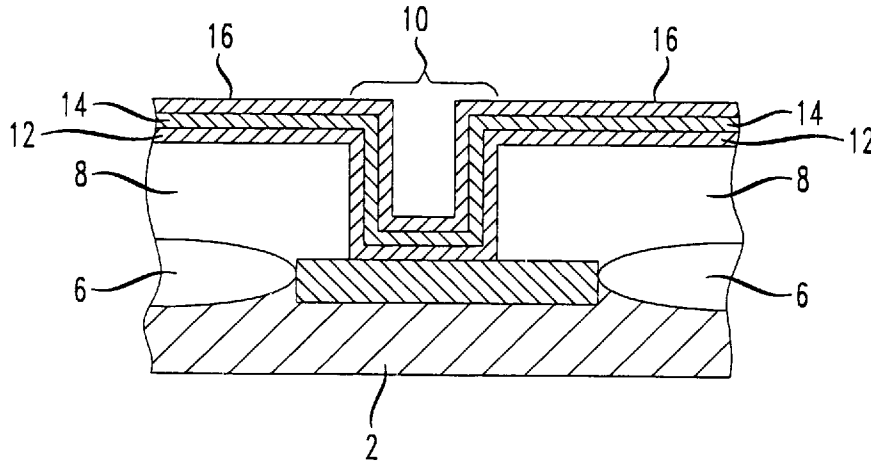
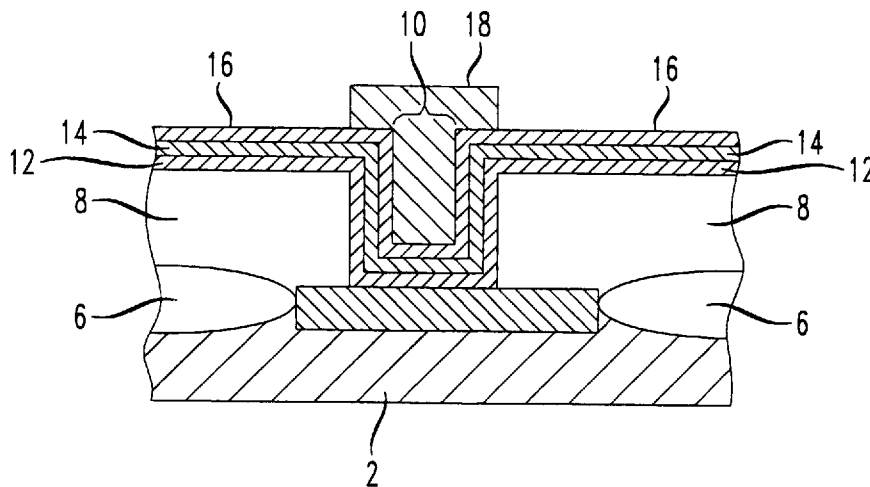

FIG. 4



**INTEGRATED CIRCUIT HAVING
AMORPHOUS SILICIDE LAYER IN
CONTACTS AND VIAS AND METHOD OF
MANUFACTURE THEREOF**

TECHNICAL FIELD OF THE INVENTION

The present invention is directed, in general, to semiconductor devices and, more specifically, to an integrated circuit having an amorphous silicide layer in contacts or vias thereof and a method of manufacture for the integrated circuit.

BACKGROUND OF THE INVENTION

The extensive use of semiconductors, such as integrated circuit ("IC") devices, in a wide range of electronic applications is well known. A typical semiconductor device is comprised of a series of contact openings ("windows") formed in a substrate material, such as silicon that has doped source and drain regions. The interconnection of these windows provides a circuit for the conduction of electrical current through the device. The windows have a metallic "plug" deposited therein, which is tungsten in most applications. The plug is overlaid with a conductive metal trace, such as aluminum-alloy, which includes, for example, aluminum-copper, aluminum-silicon or aluminum-copper-silicon. The conductive metal trace is laid down in a predetermined pattern that electrically connects the various windows to achieve the desired electrical circuit configuration within the semiconductor device.

Typically, the windows have a barrier layer of titanium overlaid with titanium nitride formed over the surface of the interior sides of the window to serve as an adhesion/nucleation layer for tungsten. Various problems, however, have arisen with respect to the metals used to form the plugs and trace patterns between these windows. For example, the titanium and titanium nitride layers are typically deposited by physical vapor deposition ("PVD"), whereas the tungsten is deposited by chemical vapor deposition ("CVD"). These different deposition methods use very different tools to achieve the deposition. Thus, the semiconductor device is placed in a PVD tool for the formation of the titanium and titanium nitride layers, removed and placed in a CVD tool to form the tungsten plug, and then returned to the PVD tool for the deposition of the aluminum-alloy interconnect. These transfers not only require time, it also subjects the device to oxidation and contaminants, which in turn, can affect the quality of the device. Moreover, because tungsten does not have a sufficiently high enough electrical conductivity, the excess tungsten that is deposited on the surface of the semiconductor device must be etched-back or polished-back prior to its return to the PVD tool, which involves yet another step in the manufacturing process. These inefficiencies increase the overall manufacturing time and cost of the semiconductor device.

In view of these disadvantages, it has become desirable to use aluminum-alloys for the metal plug. Unfortunately, however, aluminum-alloy also has problems associated with its use. It is well known that mutual diffusion of aluminum-alloy and silicon occurs between the silicon substrate and the aluminum-alloy plug when the semiconductor device is subjected to the high temperatures necessary for semiconductor manufacturing. The aluminum-alloy can diffuse into the silicon substrate to such a depth to cause a short within the semiconductor device. This phenomenon is known as junction leakage. The aluminum-alloy is able to diffuse into the silicon substrate because conventional processes pro-

duce barrier layers that have crystalline structures with grain boundaries. As such, the aluminum-alloy is capable of diffusing through these grain boundaries and into the silicon substrate.

Attempts have been made to address the problem of the diffusion problem associated with such crystalline structures. Two such attempts are disclosed in U.S. Pat. No. 4,976,839 and U.S. Pat. No. 5,514,908. Both of these patents are directed to processes that are designed to circumvent the problems associated with such crystalline structures and resulting grain boundaries existing within the barrier layers. However, they too fall short in providing a satisfactory solution in that they may form grain boundaries that might not be adequately stuffed with oxygen as a result of the complex manufacturing processes to achieve a layer boundary through which aluminum-alloy will not diffuse.

Therefore, what is need in the art is a semiconductor and a simple process for manufacturing thereof that avoids the problems associated with crystalline barrier layers that allow diffusion of the aluminum into the silicon. The semiconductor and the manufacturing process of the present invention address these needs.

SUMMARY OF THE INVENTION

The present invention provides an integrated circuit and a contact that resist junction leakage, and a method of manufacture thereof. The integrated circuit has a silicon substrate with a recess formed therein that provides an environment within which the contact is formed. The contact includes: (1) an adhesion layer deposited on an inner surface of the recess, (2) an amorphous layer deposited over the adhesion layer within the recess and (3) a central plug, composed of a conductive material, deposited at least partially within the recess. The non-crystalline amorphous layer substantially prevents the conductive material from passing through the amorphous layer to contact the adhesion layer thereby to prevent junction leakage.

In a preferred embodiment of the present invention, the adhesion layer is composed of titanium and titanium nitride and the central plug is comprised of aluminum-alloy. The titanium forms the first layer that is deposited over the silicon substrate.

In another aspect of the present invention, the adhesion layer, the central plug and the amorphous layer are deposited by DO physical vapor deposition.

The amorphous layer is preferably a silicide layer that includes an element selected from the group consisting of zirconium, molybdenum, tantalum or cobalt, and more preferably, the amorphous layer is comprised of tungsten silicide.

BRIEF DESCRIPTION OF THE DRAWINGS

For a more complete understanding of the present invention, and the advantages thereof, reference is now made to the following descriptions taken in conjunction with the accompanying drawings, in which:

FIG. 1 illustrates a cross-sectional view of an exemplary, partially manufactured integrated circuit prior to deposition of any barrier layers;

FIG. 2 illustrates a cross-sectional view of the exemplary integrated circuit device of FIG. 1 with the adhesion layer deposited thereon and within the window;

FIG. 3 illustrates a cross-sectional view of the exemplary integrated circuit device of FIG. 2 with the amorphous layer deposited over the adhesion layer and the titanium nitride barrier is layer; and

FIGS. 4 illustrates a cross-sectional view of the exemplary integrated circuit device of FIG. 3 with the metallic plug deposited within the window and after etch-back/or planarization formation of the plug.

DETAILED DESCRIPTION

Referring initially to FIG. 1, there is illustrated a cross-section portion of an integrated circuit that has been partially fabricated. At this stage of manufacture, the device's structure is entirely conventional and includes a silicon substrate 2 that has a doped diffusion region 4 formed therein, which is of opposite conductivity type from that of substrate 2. For example, substrate 2 may be a lightly doped p-type silicon and diffusion region 4 may be heavily doped n-type silicon. Of course, as noted above, other structures known to those skilled in the art may be used. For instance, the substrate 2, instead, may be a well or tub region in a CMOS process. Diffusion region 4 is bounded by a field oxide structure 6, which is also formed in a conventional manner. In this particular embodiment, diffusion 4 is very shallow, such as on the order of 0.15 microns, which is a conventional thickness for modern integrated circuits having sub-micron feature sizes. Thus, diffusion region 4 may be formed by ion implantation of the dopant followed by a high-temperature anneal to form the junctions, as is well known in the art. Alternatively, the ion implantation may be performed prior to the formation of subsequent layers, with the drive-in anneal performed later in the process, if desired.

A dielectric layer 8, which may be a deposited oxide or another type of dielectric layer, is formed over the diffusion region 4 and field oxide 6. The dielectric layer 8 electrically isolates overlying conductive structures from the diffusion region 4, except at locations where contacts therebetween are desired. A contact opening 10, which may be a window or via, has been formed through the dielectric layer 8 in a conventional manner, such as by way of reactive ion etching or another type of known anisotropic etching. Contact opening 10 may be as small as less than one micron in width, as is typical for modern sub-micron integrated circuits. Preferably, the contact opening 10 has a width that ranges from about 0.3 to about 0.8 microns and an aspect ratio that ranges from about 1.0 to about 3.0. As previously stated, each of the structures illustrated in FIG. 1 may be formed according to conventional processes known to those of skill in the art of the integrated circuit manufacture, including thicknesses of the various structures and methods of formation.

Turning now to FIG. 2, after completion of the structure illustrated in FIG. 1, a thin adhesive, but conductive, layer 12 is deposited over the inner surface of the contact opening 10 and the top portion of the substrate 2. The adhesion layer 12 is preferably deposited by sputtering or PVD techniques and at pressures and temperatures that are well known in the art. The thickness of the adhesion layer 12 may range from about 10.0 nm to about 100.0 nm. In a preferred embodiment, however, the thickness of the adhesion layer 12 is about 30.0 nm. It will, of course, be appreciated that the thickness of the adhesion layer 12 is selected according to the thickness of the amorphous layer that is to be formed at the contact location, and as such, the thickness may vary, depending on the application. In a preferred embodiment, the adhesion layer 12 is titanium, but other conductive metals known to those skilled in the art may also be used in place of titanium, such as tantalum, zirconium, hafnium, tungsten, or molybdenum. Moreover, the adhesion layer 12 may also include various stack schemes, such as titanium/titanium nitride/titanium, etc.

Turning now to FIG. 3, a layer 14 comprised of a refractory material is deposited over the adhesion layer 12 in a conventional manner to a preferred thickness of about 100.0 nm. Examples of the refractory material that can be used in the present invention are titanium nitride, titanium carbide, titanium boride, tantalum nitride, tantalum carbide, tantalum boride, zirconium nitride, zirconium carbide, zirconium boride, hafnium nitride, hafnium carbide, hafnium boride, tungsten nitride, tungsten carbide tungsten boride, molybdenum nitride, molybdenum carbide and molybdenum. Preferably, however, the refractory material is titanium nitride. A conventional PVD method at conventional temperatures that range from about 25° C. to about 400° C. and pressures that range from about 1 milli Torr to about 10 milli Torr are used to deposit the titanium nitride layer 14 in a preferred embodiment. PVD deposition techniques are preferred because the semiconductor device does not have to be transferred to a different tool, which decreases manufacturing time and eliminates particle defects and contamination problems associated with moving the device from one deposition tool to another. As discussed in the art, the PVD deposition of titanium nitride apparently forms a layer 14 having a crystalline structure with grain boundaries. As such, this layer 14 does not serve as a good boundary layer to prevent diffusion of aluminum-alloy into silicon. Accordingly, the present invention provides an amorphous, non-crystalline layer that is deposited over the layer 14.

Continuing to refer to FIG. 3, an amorphous layer 16, in accordance with the present invention, is shown deposited over the titanium nitride layer 14. The amorphous layer 16 is preferably deposited by conventional PVD techniques at a temperature that ranges from about 25° C. to about 400° C. and at pressures that range from about 1 milli Torr to about 20 milli Torr. More preferably, however, the deposition temperature is about 400° C. and the deposition pressure is about 2 milli Torr. The PVD tool used to deposit the amorphous layer 16 is a conventional PVD tool, well known to those skilled in the art and is the same tool used to deposit the previously-discussed adhesive and titanium nitride layers.

Experimental results indicate that the amorphous layer 16 is non-crystalline, and thus, does not have the grain boundaries associated with crystalline structures found in the prior art. Thus, the amorphous layer 16 provides a continuous layer through which a metal plug, such as aluminum-alloy cannot diffuse. Moreover, the amorphous layer 16 can be deposited using the same PVD methods used to deposit the adhesion layer 12 and the titanium nitride layer 14. As such, the semiconductor device does not have to be transferred to another deposition tool, such as a CVD tool, as is typically done in conventional processes. In most applications in the art, the semiconductor device is removed from the PVD tool following deposition of the titanium nitride layer and transferred to a CVD tool where a tungsten plug is deposited over the titanium nitride layer. As previously discussed, because the vacuum on the tool must be broken to transfer the device, this subjects the semiconductor device to possible defects and contamination from the environment during the transfer from one tool to another. Further, manufacturing time, and thus, the cost of the device increase with these transfers. Because the amorphous layer 16 can be deposited with PVD techniques, the problems of the prior art are avoided; that is, the vacuum on the tool can be maintained, which greatly reduces the risks of oxidation and environmental contamination.

In a preferred embodiment, the amorphous layer 16 is a metal-silicide layer. The silicon is bonded with a metal

Explore Litigation Insights

Docket Alarm provides insights to develop a more informed litigation strategy and the peace of mind of knowing you're on top of things.

Real-Time Litigation Alerts



Keep your litigation team up-to-date with **real-time alerts** and advanced team management tools built for the enterprise, all while greatly reducing PACER spend.

Our comprehensive service means we can handle Federal, State, and Administrative courts across the country.

Advanced Docket Research



With over 230 million records, Docket Alarm's cloud-native docket research platform finds what other services can't. Coverage includes Federal, State, plus PTAB, TTAB, ITC and NLRB decisions, all in one place.

Identify arguments that have been successful in the past with full text, pinpoint searching. Link to case law cited within any court document via Fastcase.

Analytics At Your Fingertips



Learn what happened the last time a particular judge, opposing counsel or company faced cases similar to yours.

Advanced out-of-the-box PTAB and TTAB analytics are always at your fingertips.

API

Docket Alarm offers a powerful API (application programming interface) to developers that want to integrate case filings into their apps.

LAW FIRMS

Build custom dashboards for your attorneys and clients with live data direct from the court.

Automate many repetitive legal tasks like conflict checks, document management, and marketing.

FINANCIAL INSTITUTIONS

Litigation and bankruptcy checks for companies and debtors.

E-DISCOVERY AND LEGAL VENDORS

Sync your system to PACER to automate legal marketing.