

- [54] **PROCESS OF MAKING TWIN WELL VLSI CMOS**
 [75] **Inventor:** John T. Gasner, Melbourne, Fla.
 [73] **Assignee:** Harris Corporation, Melbourne, Fla.
 [21] **Appl. No.:** 620,835
 [22] **Filed:** Jun. 15, 1984
 [51] **Int. Cl.⁴** H01L 21/265; B01J 17/00
 [52] **U.S. Cl.** 29/571; 29/576 B;
 148/1.5; 148/187; 156/643; 357/42; 357/91
 [58] **Field of Search** 148/1.5, 187; 29/571,
 29/576 B; 156/643; 357/91, 42

4,453,306 6/1984 Lynch et al. 29/571

OTHER PUBLICATIONS

"Fabrication of High-Performance LDDFET's with Oxide Sidewall-Spacer Technology"; Tsang et al.; IEEE; vol. ED-29, No. 4, Apr. 1982, pp. 590-596.
 "An Optimally Designed Process for Submicrometer MOSFET's"; Shibata et al.; IEEE, vol. ED-29, No. 4, Apr. 1982, pp. 531-535.
 "Twin-Tub CMOS—A Technology for VLSI Circuits"; Parrillo et al.; IEDM, 1980, pp. 752-755.
 "Twin-Tub CMOS II—An Advanced VLSI Technology"; Parrillo et al.; IEDM 1982, pp. 706-709.
 "Quadruple-Wall CMOS—A VLSI Technology"; Chen; IEDM 1982, pp. 791-792.

[56] **References Cited**

U.S. PATENT DOCUMENTS

3,759,763	9/1973	Wang	148/188
4,209,350	6/1980	Ho et al.	148/188
4,280,272	7/1981	Egawa et al.	29/571
4,319,395	3/1982	Lund et al.	29/571
4,333,099	6/1982	Tanguay et al.	357/67
4,343,082	8/1982	Lepselter et al.	29/576 B
4,356,040	10/1982	Fu et al.	148/1.5
4,356,623	11/1982	Hunter	29/571
4,366,613	1/1983	Ogura et al.	29/571
4,385,947	5/1983	Halfacre et al.	148/187
4,411,058	10/1983	Chen	29/571
4,420,344	12/1983	Davies	148/1.5
4,434,543	3/1984	Schwabe et al.	29/576 B
4,435,896	3/1984	Parrillo et al.	29/571
4,442,591	4/1984	Haken	29/571
4,444,605	4/1984	Slawinski	148/187

Primary Examiner—Upendra Roy
Attorney, Agent, or Firm—Barnes & Thornburg

[57] **ABSTRACT**

CMOS devices are formed in self-aligned wells in a substrate produced by a two mask, one photolithographic step process wherein the first mask is used as a template to form the second inverse mask of substantially equal thickness. The gates are used as alignment mask for shallow source and drain regions and subsequently formed lateral gate spacers are used as alignment mask for deep source and drain regions. Exposed source and drain regions and silicon gates have silicide formed thereon by a non-selective process.

14 Claims, 20 Drawing Figures

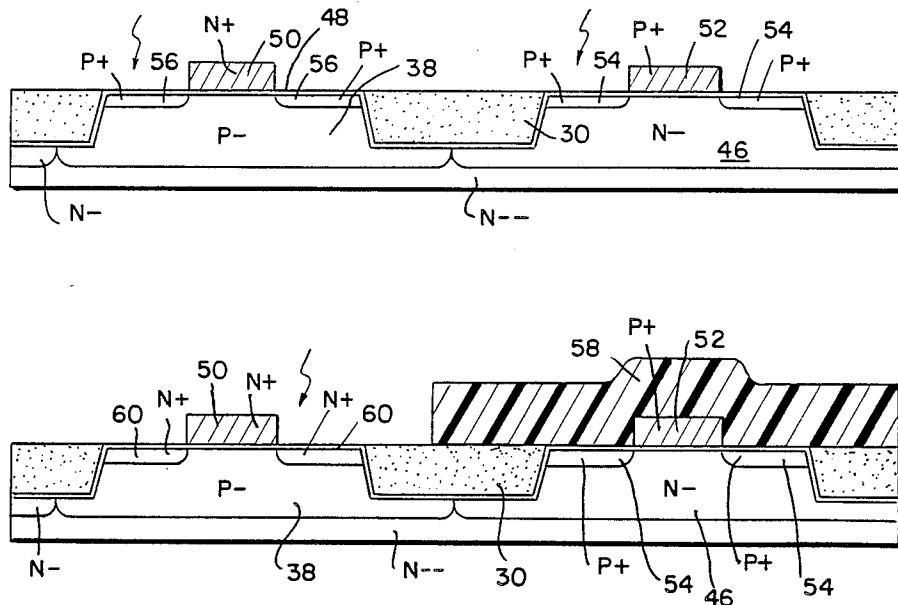

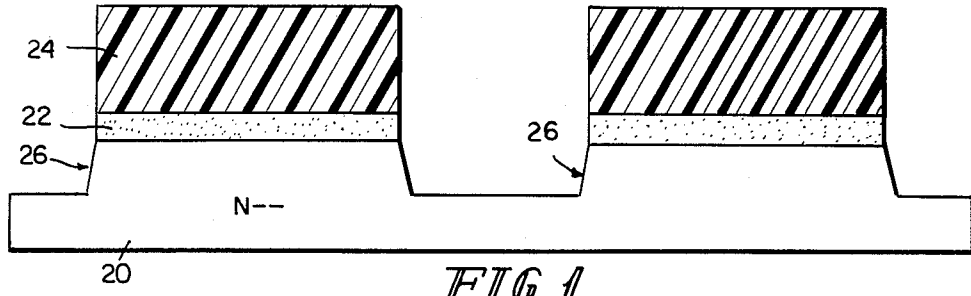

FIG 1

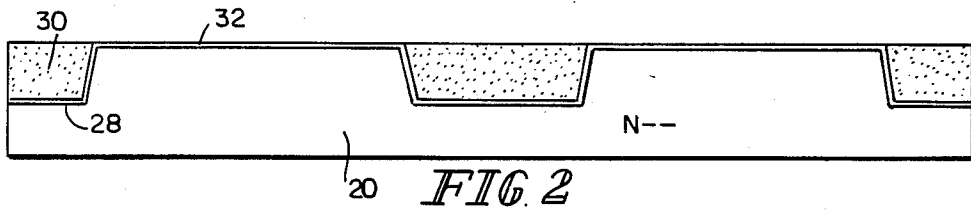

FIG 2

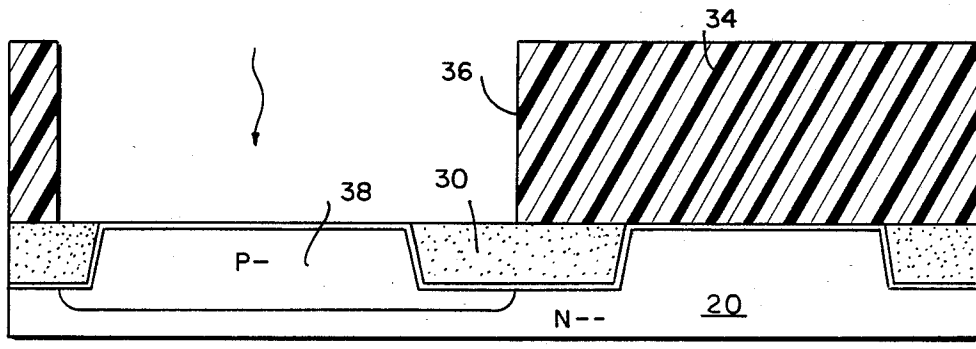

FIG 3

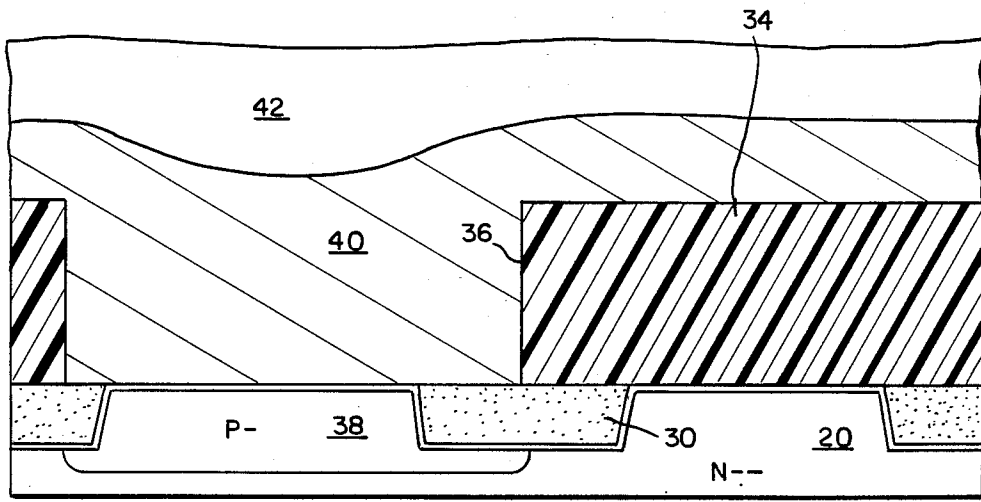

FIG 4

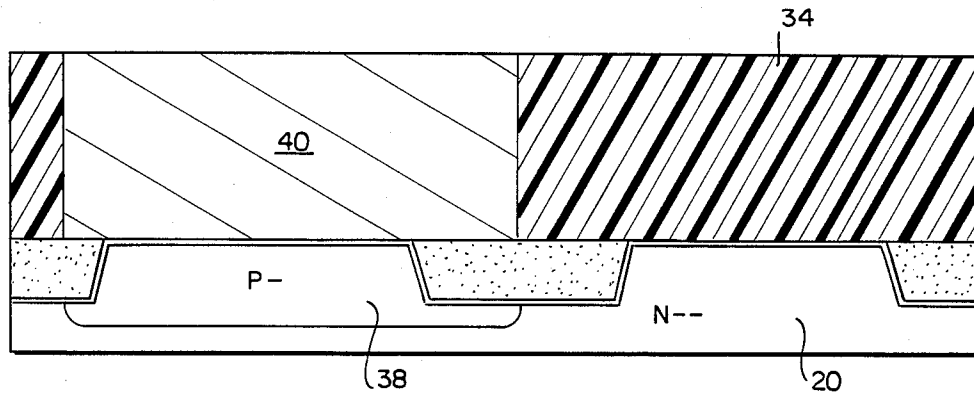

FIG 5

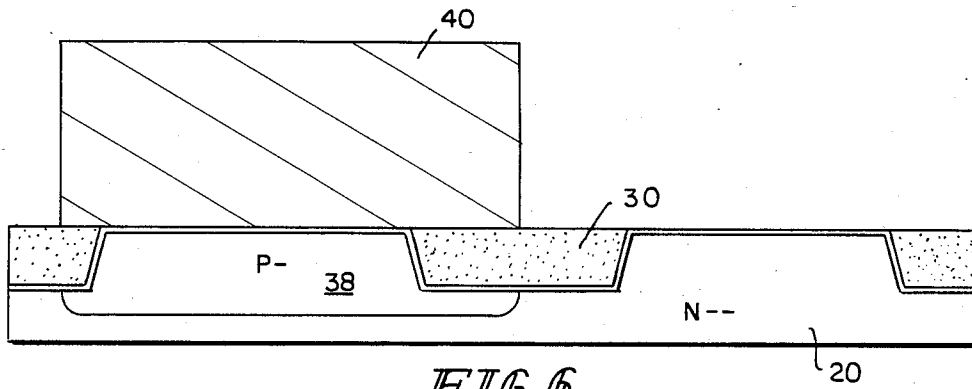

FIG 6

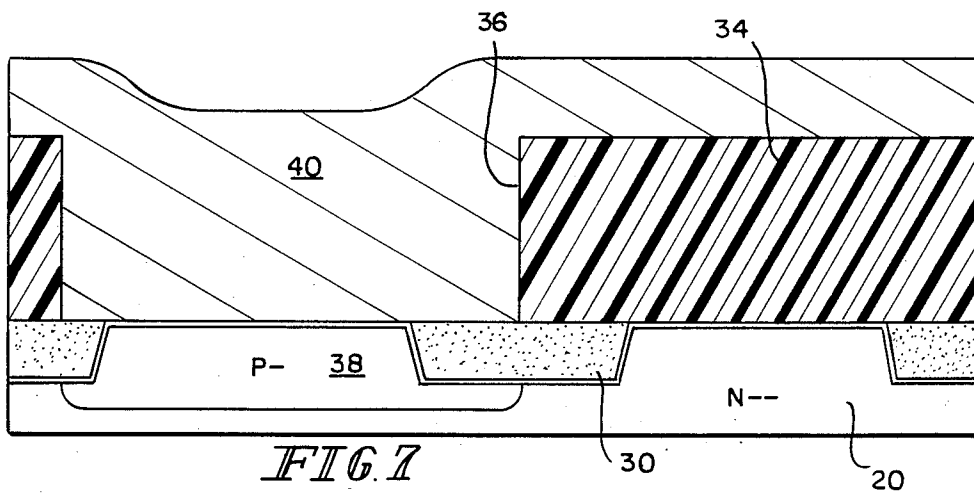

FIG 7

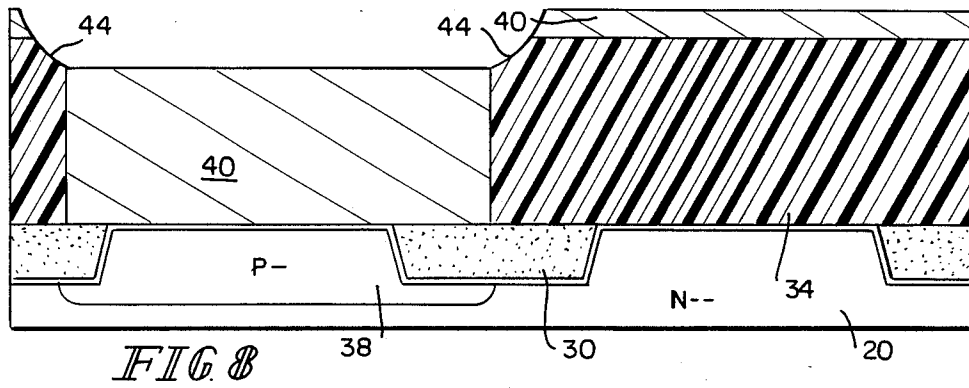

FIG 8

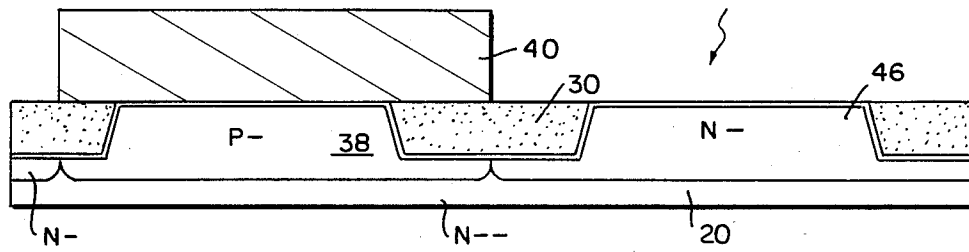

FIG 9

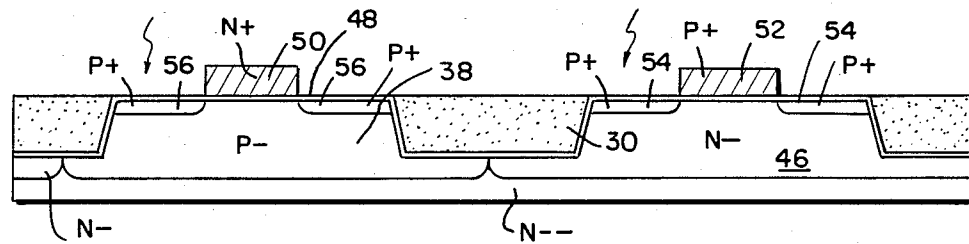

FIG 10

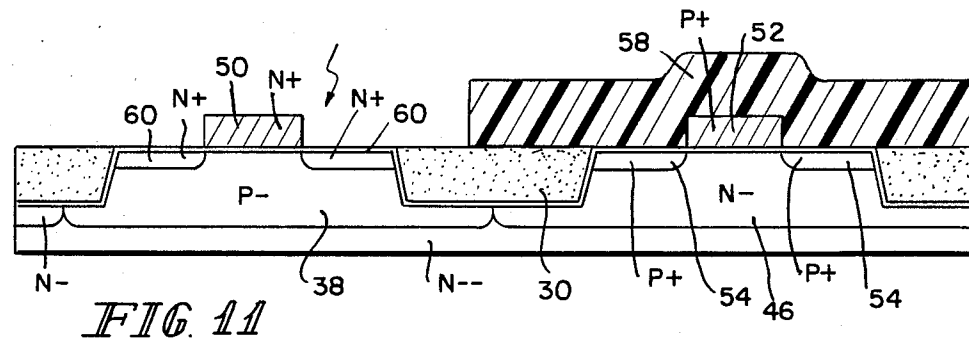

FIG 11

Explore Litigation Insights

Docket Alarm provides insights to develop a more informed litigation strategy and the peace of mind of knowing you're on top of things.

Real-Time Litigation Alerts



Keep your litigation team up-to-date with **real-time alerts** and advanced team management tools built for the enterprise, all while greatly reducing PACER spend.

Our comprehensive service means we can handle Federal, State, and Administrative courts across the country.

Advanced Docket Research



With over 230 million records, Docket Alarm's cloud-native docket research platform finds what other services can't. Coverage includes Federal, State, plus PTAB, TTAB, ITC and NLRB decisions, all in one place.

Identify arguments that have been successful in the past with full text, pinpoint searching. Link to case law cited within any court document via Fastcase.

Analytics At Your Fingertips



Learn what happened the last time a particular judge, opposing counsel or company faced cases similar to yours.

Advanced out-of-the-box PTAB and TTAB analytics are always at your fingertips.

API

Docket Alarm offers a powerful API (application programming interface) to developers that want to integrate case filings into their apps.

LAW FIRMS

Build custom dashboards for your attorneys and clients with live data direct from the court.

Automate many repetitive legal tasks like conflict checks, document management, and marketing.

FINANCIAL INSTITUTIONS

Litigation and bankruptcy checks for companies and debtors.

E-DISCOVERY AND LEGAL VENDORS

Sync your system to PACER to automate legal marketing.