

**T.O. DEPARTMENT  
CERTIFICATION**

**ALLERGAN**

2525 Dupont Drive, P.O. Box 19534, Irvine, California, USA 92623-9534 Telephone: (714) 246-4500 Website: www.allergan.com



**1.6 DEBARMENT CERTIFICATION**

Under the provisions of Section 306(k) of the Federal Food, Drug and Cosmetic Act, Allergan, Inc. has made a diligent effort to insure that no individual, corporation, partnership or association debarred under Section 306(a) or 306(b) of the Act, as referenced above, has provided any services in connection with this application.

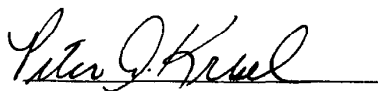

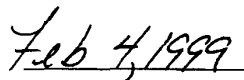

Peter Kresel, MS, MBA

(date)

Sr. Vice President, Global Regulatory Affairs

Allergan, Inc.

**1.7 FIELD COPY  
CERTIFICATION**



**ALLERGAN**

2525 Dupont Drive, P.O. Box 19534, Irvine, California, USA 92623-9534 Telephone: (714) 246-4500 Website: www.allergan.com



**1.7 FIELD COPY CERTIFICATION**

Allergan, Inc. hereby certifies that the Chemistry, Manufacturing and Control section of this New Drug Application along with a copy of FDA Form 356h and the Summary section have been submitted to the FDA Dallas District Office as required by 21 CFR 314.50(k)(3). We further certify that the field copy is an identical copy of the sections as they appear in the archival and review copy of the application.



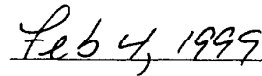

Peter Kresel, MS, MBA

(date)

Sr. Vice President, Global Regulatory Affairs

Allergan, Inc.



**1.8 FINANCIAL  
CERTIFICATION**



72176 Federal Register / Vol. 63, No. 251 / Thursday, December 31, 1998 / Rules and Regulations

DEPARTMENT OF HEALTH AND HUMAN SERVICES Public Health Service Food and Drug Administration  <b>CERTIFICATION: FINANCIAL INTERESTS AND ARRANGEMENTS OF CLINICAL INVESTIGATORS</b>	Form Approved: OMB No. XXXX-XXXX Expiration Date: XX/XX/XX
TO BE COMPLETED BY APPLICANT	
With respect to all covered clinical studies (or specific clinical studies listed below (if appropriate)) submitted in support of this application, I certify to one of the statements below as appropriate. I understand that this certification is made in compliance with 21 CFR part 54 and that for the purposes of this statement, a clinical investigator includes the spouse and each dependent child of the investigator as defined in 21 CFR 54.2(d).	
Please mark the applicable checkbox.	
<input checked="" type="checkbox"/> (1) As the sponsor of the submitted studies, I certify that I have not entered into any financial arrangement with the listed clinical investigators (enter names of clinical investigators below or attach list of names to this form) whereby the value of compensation to the investigator could be affected by the outcome of the study as defined in 21 CFR 54.2(a). I also certify that each listed clinical investigator required to disclose to the sponsor whether the investigator had a proprietary interest in this product or a significant equity in the sponsor as defined in 21 CFR 54.2(b) did not disclose any such interests. I further certify that no listed investigator was the recipient of significant payments of other sorts as defined in 21 CFR 54.2(f).	
Clinical Investigator	List Attached
<input type="checkbox"/> (2) As the applicant who is submitting a study or studies sponsored by a firm or party other than the applicant, I certify that based on information obtained from the sponsor or from participating clinical investigators, the listed clinical investigators (attach list of names to this form) did not participate in any financial arrangement with the sponsor of a covered study whereby the value of compensation to the investigator for conducting the study could be affected by the outcome of the study (as defined in 21 CFR 54.2(a)); had no proprietary interest in this product or significant equity interest in the sponsor of the covered study (as defined in 21 CFR 54.2(b)); and was not the recipient of significant payments of other sorts (as defined in 21 CFR 54.2(f)).	
<input type="checkbox"/> (3) As the applicant who is submitting a study or studies sponsored by a firm or party other than the applicant, I certify that I have acted with due diligence to obtain from the listed clinical investigators (attach list of names) or from the sponsor the information required under 54.4 and it was not possible to do so. The reason why this information could not be obtained is attached.	
NAME	TITLE
Francis R. Tunney, Jr.	Acting Chief Financial Officer
FIRM/ORGANIZATION	
Allergan, Inc.	
SIGNATURE	DATE
<i>Francis R. Tunney, Jr.</i>	2/23/99
Paperwork Reduction Act Statement An agency may not conduct or sponsor, and a person is not required to respond to, a collection of information unless it displays a currently valid OMB control number. Public reporting burden for this collection of information is estimated to average 1 hour per response, including time for reviewing instructions, searching existing data sources, gathering and maintaining the necessary data, and completing and reviewing the collection of information. Send comments regarding this burden estimate or any other aspect of this collection of information to the address to the right.	
Department of Health and Human Services Food and Drug Administration 5600 Fishers Lane, Room 14C-03 Rockville, MD 20857	Please <b>DO NOT RETURN</b> this form to this address.

FORM FDA 3454 (10/98)

BT  
Created by Electronic Document Services/USDHHS (001) 441-3414

BILLING CODE 4160-01-C

NDA 21-023  
Cyclosporine ophthalmic emulsion 0.05%

Allergan

### Financial Disclosure

#### Principal Investigators

Name	Comments
Asbell, Penny	
Barber, Laurie	
Berdy, Gregg	
Burke, Moira	
Cavanagh, Dwight	
Donshtik, Peter	
Foerster, Robert	
Forstot, Lance S.	
Foulks, Gary	
Friedleander, Mitchell	
Friedman, Robert	
Gruber, Alan	
Hartman, Paul	
Heidemann, David	
Hu, Dean	
Mamalis, Nick	
McGarey, David	
Mundorf, Thomas	
Nelson, Daniel J.	
O'Day, David	
Ostrov, Charles	
Perry, Henry	
Pflugfelder, Steven	
Sall, Kenneth	
Sansone, Michael	
Schanzlin, David	
Schiffman, Rhett	

1 of 3

NDA 21-023  
Cyclosporine ophthalmic emulsion 0.05%

Allergan

Sheppard, John	
Stamler, John	
Stewart, William	
Stonecipher, Karl	
Tauber, Joseph	
Trocme, Stefan	
Walters, Thomas	
Williams, Robert	
Yee, Richard	
	
Sub-investigators	
<i>Name</i>	<i>Comments</i>
Baron, Gregory	
Bodner, Bruce	
Brusatti, Robert	
Bongard, Bonnie-	
Cavanaugh, Timothy	
Donnenfeld, Eric	
Dunn, Steven	
Gill, Kuljit	
Gurevich, Leonard	
Gwizdak, Krzysztof	
Huang, Andrew	
Linder, James	
McGuinness, James	
Monacelli, Ronald	
Montgomery, James	
Muhich, Anthony	

2 of 3

NDA 21-023  
Cyclosporine ophthalmic emulsion 0.05%

Allergan

Patel, Ghanshyam  
Robin, Steven  
Rymer, Robert  
Schenker, Howard  
Sharpe, Elizabeth  
Steinmann, Thomas  
Thatcher, Darryl  
Tredici, Tomas  
Twa, Michael

3 of 3



Financial Disclosure by Clinical Investigators (U.S.)

Financial Disclosure by Clinical Investigators

Investigator or Subinvestigator Name (Last, First, Middle Initial)		Date	Study Number
Greenberg, Marvin E		2/19/99	192371-003
Study Phase		Method of Information Collection	
<input type="checkbox"/>	Prestudy	<input checked="" type="checkbox"/>	Telephone contact
<input checked="" type="checkbox"/>	On-going monitoring (Only to be done for investigators/subinvestigators from whom information has not been previously collected for this study)	<input type="checkbox"/>	Site visit
<input checked="" type="checkbox"/>	Site close-out		
<input type="checkbox"/>	One year after close-out		
Question		Response	Comments
		If yes, describe briefly; If investigator does not provide information, state reason for refusal	
1.	Have you, your spouse or your dependent children entered into a financial arrangement with Allergan whereby the value of the compensation could be influenced by the outcome of the study?	<input type="checkbox"/> Yes <input checked="" type="checkbox"/> No	
2.	Have you, your spouse or your dependent children received any significant payments of other sorts (see definitions for clarification, if necessary) totaling more than \$25,000 (US) made on or after February 2, 1999 from Allergan? (Payment of other sorts would include a grant to fund ongoing research, compensation in the form of equipment, retainer for ongoing consultation, honoraria, etc.)	<input type="checkbox"/> Yes <input checked="" type="checkbox"/> No	
3.	Do you, your spouse or your dependent children have any proprietary interest in the product being tested?	<input type="checkbox"/> Yes <input checked="" type="checkbox"/> No	
4.	Do you, your spouse or your dependent children have any equity interest (i.e., Allergan stock) greater than \$50,000 (US)?	<input checked="" type="checkbox"/> Yes <input type="checkbox"/> No	1500 shares purchased 7-97 in my IRA.
Allergan Representative Obtaining Information: <i>Sandra Heston</i>			
Version date: February 1999			

174  
2b-199





Feb-10-99 09:12pm From-ALLERGAN CLIN RES

7142486758

T-740 P. 03/93 P-708

Financial Disclosure by Clinical Investigators (U.S.)

Financial Disclosure by Clinical Investigators

Investigator or Subinvestigator Name (Last, First, Middle Initial)		Date	Study Number
STEVENSON, O. DARA		2/1/99	#192371-004 #192371-002 #192371-005 #190342-007
Study Phase		Method of Information Collection	
<input checked="" type="checkbox"/> Prestudy		<input checked="" type="checkbox"/> Telephone contact	On 2/1/99
<input checked="" type="checkbox"/> On-going monitoring (Only to be done for investigators/subinvestigators from whom information has not been previously collected for this study)		<input type="checkbox"/> Site visit	
<input type="checkbox"/> Site close-out			
<input type="checkbox"/> One year after close-out			
Question		Response	Comments If yes, describe briefly; if investigator does not provide information, state reason for refusal
1. Have you, your spouse or your dependent children entered into a financial arrangement with Allergan whereby the value of the compensation could be influenced by the outcome of the study?	<input type="checkbox"/> Yes <input checked="" type="checkbox"/> No		
2. Have you, your spouse or your dependent children received any significant payments of other sorts (see definitions for clarification, if necessary) totaling more than \$25,000 (US) made on or after February 2, 1999 from Allergan? (Payment of other sorts would include a grant to fund ongoing research, compensation in the form of equipment, retainer for ongoing consultation, honoraria, etc.)	<input type="checkbox"/> Yes <input checked="" type="checkbox"/> No		
3. Do you, your spouse or your dependent children have any proprietary interest in the product being tested?	<input type="checkbox"/> Yes <input checked="" type="checkbox"/> No		
4. Do you, your spouse or your dependent children have any equity interest (i.e., Allergan stock) greater than \$50,000 (US)?	<input checked="" type="checkbox"/> Yes <input type="checkbox"/> No		SLP 1,000 Shares Allergan Stock
Allergan Representative Obtaining Information: <i>Jane Metherway</i>			
Version date: February 1999			

**1.9 NOTES TO  
REVIEWER  
AND ERRATA**

## 1.9 NOTES TO REVIEWER AND ERRATA

### 1.9.1 NOTES TO REVIEWER

#### Electronic Copy of the NDA

Included with this paper copy of this NDA are 4 CD Rom disks which contain an electronic copy of the entire NDA. The files on the CDs were created by the CoreDossier® Publishing System (version 3.1.2), and are in Adobe Portable Document Format (.pdf). The files can be navigated by use of a large blue circular pointer on the first and last page of each electronic volume. The files can also be navigated by viewing the volview.pdf or docview.pdf files in the System Folder located on Disk 1. If more detailed information or instructions are needed, please contact Allergan at (714) 246-4391.

#### Color Copies of Photographs

Color copies of photographs within the following studies will be found immediately after the black and white version of the same page. The duplicate pages with the color photographs are not paginated.

BIO-98-274	Topical ophthalmic evaluation of cyclosporine (0.05%,0.2% bid for 12 weeks) in dry eye dogs. Allergan, 1998.	vol. 13 p. 342
BIO-98-275	Evaluation of topical cyclosporine (0.2% bid for 12 weeks) in dry eye dogs. Effects on lymphocytic and acinar epithelial cell apoptosis are evaluated. Allergan, 1998	vol. 13 p. 356
8.11.7	Investigator Summary Report of Conjunctival Biopsy	vol. 85 p. 029

### 1.9.2 ERRATA

In some places in the NDA on Index entries, certain tabs and volume cover pages, the clinical study reports are listed by the following numbers:

192371-002 or 192731-002 and 192371-003 or 192731-003

A typographical error was made in some locations; the correct project number is 192371.

#### Replacement Investigator

During the conduct of clinical study 192371-003, Allergan was informed by Dr. Robert Laibovitz that he was unable to continue in the study. Allergan informed the Agency at that time. The study patients were transferred to Dr. Thomas Walters in Austin, Texas.

Dr. Walters' name and address information was inadvertently omitted from Section 8.2 Investigators, INDs and NDAs, Table 8.2.1 List of Investigators. This information is included below. However, Dr. Walters' Curriculum Vitae and Statement of Investigator Form 1572 are included in Section 8.11.3, Clinical Study Report 192371-003, Appendix 14.3, Principal Investigator Curricula Vitae and Copies of Statement of Investigator Forms 1572. [vol. 62 p. 315]

Table 8.2.1 Investigator List (amendment)

Principal Investigator	Investigator Number	Study Identifier
Thomas R. Walters, M.D. Texan Eye Care 1700 South Mopac Austin, TX 78746	1634	192371-003

**SECTION 2**

<b>Section 2</b>	<b>Vol.</b>	<b>Page</b>
Section 2 LABELING .....	1	159
2.1 ANNOTATED LABELING .....	1	159
2.2 DRAFT LABELING.....	1	175

**2.1 ANNOTATED  
LABELING**



## RESTASIS™

(cyclosporine ophthalmic emulsion) 0.05%

Sterile, Preservative-Free

### DESCRIPTION

RESTASIS™ (cyclosporine ophthalmic emulsion) 0.05% is an immunomodulator with anti-inflammatory effects when used in patients with dry-eye disease. Cyclosporine's chemical name is Cyclo[[*(E)*-(2*S*,3*R*,4*R*)-3-hydroxy-4-methyl-2-(methylamino)-6-octenoyl]-L-2-aminobutyryl-*N*-methylglycyl-*N*-methyl-L-leucyl-L-valyl-*N*-methyl-L-leucyl-L-alanyl-D-alanyl-*N*-methyl-L-leucyl-*N*-methyl-L-leucyl-*N*-methyl-L-valyl] and it has the following structure:

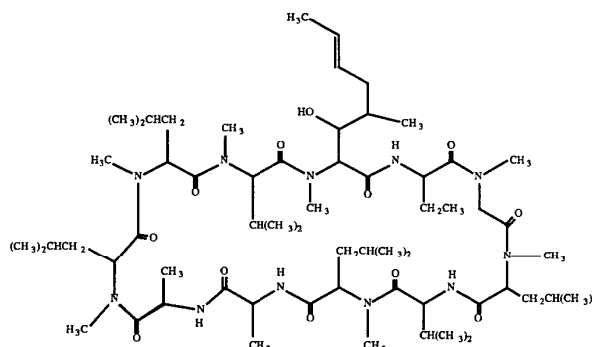

Formula:  $C_{62}H_{111}N_{11}O_{12}$  Mol. Wt.: 1202.6

Cyclosporine is a fine white powder. RESTASIS™ appears as a white opaque to slightly translucent homogeneous emulsion. It has an Osmolality of 240 to 280 mOsmol/kg and a pH of 7.0-7.8.

Each mL of RESTASIS™ contains: Active ingredient: cyclosporine 0.05%. Inactives: carbomer 1342; castor oil; glycerin; polysorbate 80; sodium hydroxide to adjust the pH; and purified water.



## CLINICAL PHARMACOLOGY

### Mechanism of action:

In dry-eye disease, cyclosporine emulsion acts as a potent, but selective immunomodulator, an anti-inflammatory agent, and a direct inhibitor of pathological epithelial apoptosis.

### Immunomodulation:

Cyclosporine leaves critical functions of host immunity intact (Belin et al, 1990; Kahan, 1994; Kahan et al, 1983). Only the early stages of T-cell activation (helper T-cells) and not the lymphocytic effector stages responsible for elimination of intruder cells are suppressed (Borel et al, 1996; Kahan, 1989).

Topical cyclosporine emulsion achieves its immunomodulatory activity by inhibiting the activation of NF- $\kappa$ B, a nuclear factor involved in the regulation of immune and pro-inflammatory cytokine response genes, such as TNF, IL-1, IL-2, and IL-8 (Meyer et al, 1997; Boss et al, 1998).

### Anti-inflammatory:

Helper T cells identified in the tissues of the ocular surface and lacrimal glands play an important role not only in the immune response, but also in the inflammatory response through cytokine synthesis. Cyclosporine prevents the synthesis and/or secretion of several pro-inflammatory cytokines (Schliephake et al, 1997; Mitruka et al, 1998; Svecova et al, 1998; Pette et al, 1997). It is also known to upregulate secretion of anti-inflammatory cytokines (van der Pouw Kraan et al, 1996).

### Inhibition of pathological apoptosis:

Inflammatory conditions can direct pathological apoptosis of secretory acinar epithelial cells and facilitate accumulation of lymphocytic infiltrates within the lacrimal glands and conjunctival epithelium. These events result in loss of normal glandular structure and its secretory function. Cyclosporine has been reported to be a direct inhibitor of pathological apoptosis of acinar epithelium cells (Scorrano et al, 1997) and has been shown to reverse pathological acinar apoptosis and lymphocyte proliferation in dry eye dogs (Gao et al, 1998).

### **Pharmacokinetics:**

Blood cyclosporin A concentrations were measured using a specific high pressure liquid chromatography-mass spectrometry assay. Blood concentrations of cyclosporine A, in all the samples collected, after topical administration of RESTASIS™ 0.05%, BID, in humans for up to 12 months, were below the quantitation limit of 0.1 ng/mL (study reports PK-98-109, PK-98-112). These levels are more than 6550 times lower than those measured during systemic cyclosporine treatment for non-life-threatening indications. There was no detectable drug accumulation in blood during 12 months of treatment with RESTASIS™. As a result of these findings no renal or hepatic cytotoxicity would be expected to occur following the use of RESTASIS™.

Maximal concentrations obtained from rabbit and dog studies indicate that the great majority of drug contained in ocular tissues after ophthalmic administration resides in the outer layers of the eye, and that little penetrates to the interior (study reports PK-95-010, PK-96-016, PK-96-017, and PK-98-074). High concentrations and long half-lives in ocular surface tissues suggest that these tissues act as a reservoir for cyclosporine, sequestering cyclosporine and releasing it slowly over prolonged periods. Half-lives in conjunctiva, cornea and sclera after multiple ophthalmic doses to albino rabbits ranged from 32 to 52 hours (study reports PK-95-010 & PK-98-074). Half-lives in beagle dogs after multiple ophthalmic doses were also longer than 24 hours (study reports PK-96-016 & PK-96-017).

Cyclosporine is not metabolized by ocular tissues in albino rabbits.

### **Clinical Evaluations:**

RESTASIS™ achieved clinically and statistically significant results versus vehicle for the individual parameters corneal staining, blurred vision, categorized Schirmer with anesthesia, and reduction in artificial tear use. Improvement from baseline with RESTASIS™ was seen in virtually all efficacy parameters (study reports 192371-002 & 192371-003). In addition no bacterial or fungal ocular infections were reported following administration of RESTASIS™ (study reports 192371-001, 192371-002 & 192371-003).

Results of additional tests performed in the clinical trial following 6 months of treatment showed that RESTASIS™ reduces the inflammation, immune reactivity underlying KCS and improves ocular surface health and tear film in dry-eye patients with and without Sjögren's syndrome (tertiary reports: conjunctival biopsies, 1999; IL-6, 1999; goblet cell density, 1999).

Inflammatory cytokine IL-6 levels in the conjunctival epithelium showed a statistically significant decrease from baseline (tertiary report IL-6, 1999). Conjunctival biopsies showed: the immune activation marker HLA-DR decreased 34% compared to a 160% increase with vehicle, the inflammation marker CD11a decreased 11% compared to a 104% increase with vehicle, CD3 (total T cells) and CD8 (T suppressor cells) decreased compared to an increase with vehicle, goblet cell density increased 191% compared to an increase of only 13% with vehicle (tertiary reports: conjunctival biopsies, 1999; goblet cell density, 1999).

#### **INDICATIONS AND USAGE**

RESTASIS™ is indicated for the treatment of moderate to severe keratoconjunctivitis sicca; it restores and maintains normal tear secretion and ocular surface integrity while providing relief of symptoms associated with dry-eye (NDA Section 8.6).

#### **CONTRAINDICATIONS**

RESTASIS™ is contraindicated in patients with active, ocular infection and in patients with previously demonstrated hypersensitivity to any of the ingredients in the formulation.

#### **WARNING**

RESTASIS™ has not been studied in patients with a history of recurrent herpes keratitis.

#### **PRECAUTIONS**

##### **Information for Patients:**

To avoid contamination, do not touch the tip of the vial to the eye or any other surface. Use the contents of the vial within 12 hours after opening and discard. RESTASIS™ should not be administered while wearing contact lenses. Patients should be advised not to discontinue therapy prematurely. Also refer to attached patient information.

### **Drug Interactions:**

There is little information regarding the interaction of ophthalmic drugs co-administered with topical ophthalmic cyclosporine. Systemic exposure of cyclosporin A from RESTASIS™ is minimal. Therefore, no interaction of topically applied RESTASIS™ with systemic drugs is expected to occur.

### **Carcinogenesis, Mutagenesis, and Impairment of Fertility:**

Systemic carcinogenicity studies were carried out in male and female mice and rats. In the 78-week oral (diet) **mouse** study, at doses of 1, 4, and 16 mg/kg/day, evidence of a statistically significant trend was found for lymphocytic lymphomas in females, and the incidence of hepatocellular carcinomas in mid-dose males significantly exceeded the control value.

In the 24-month oral (diet) **rat** study, conducted at 0.5, 2, and 8 mg/kg/day, pancreatic islet cell adenomas significantly exceeded the control rate in the low dose level. The hepatocellular carcinomas and pancreatic islet cell adenomas were not dose related (PDR NEORAL®, 1998). The low doses in mice and rats are approximately 1000 and 500 times greater, respectively, than the daily human dose of one drop (35 µL) of RESTASIS™ BID into each eye (0.001 mg/kg), assuming that the entire dose is absorbed.

Cyclosporine has not been found mutagenic/genotoxic in the Ames Test, the V79-HGPRT Test, the micronucleus test in mice and Chinese hamsters, the chromosome-aberration tests in Chinese hamster bone-marrow, the mouse dominant lethal assay, and the DNA-repair test in sperm from treated mice. A recent study analyzing sister chromatid exchange (SCE) induction by cyclosporine using human lymphocytes *in vitro* gave indication of a positive effect (i.e., induction of SCE), at high concentrations in this system (PDR NEORAL®, 1998).

No impairment in fertility was demonstrated in studies in male and female rats (PDR NEORAL®, 1998).

**Pregnancy:**

Pregnancy Category: B

Teratogenic effects: Cyclosporine was found to be non-teratogenic in appropriate test systems. Rats at up to 17 mg/kg/day and rabbits at up to 30 mg/kg/day, dosed with cyclosporine oral solution, USP proved to be without any embryo-lethal or teratogenic effects (Sandoz NDA 50-573 and 50-574).

These doses in rats and rabbits are approximately 17,000 and 30,000 times greater, respectively, than the daily human dose of one drop (35 µl) RESTASIS™ BID into each eye (0.001 mg/kg), assuming that the entire dose is absorbed.

Non-Teratogenic effects: Adverse effects were seen in reproduction studies in rats only at dose levels toxic to dams. At toxic doses (rats at 30 mg/kg/day and rabbits at 100 mg/kg/day), cyclosporine oral solution, USP, was embryo- and fetotoxic as indicated by increased pre- and postnatal mortality and reduced fetal weight together with related skeletal retardations (Sandoz NDA 50-573 and 50-574). These doses are 30,000 times and 100,000 times greater, respectively than the daily human dose of one-drop (35 µl) of RESTASIS™ BID into each eye (0.001 mg/kg), assuming that the entire dose is absorbed.

There are no adequate and well-controlled studies of RESTASIS™ in pregnant women. RESTASIS™ should be administered to a pregnant woman only if clearly needed.

**Nursing Mothers:**

Cyclosporine is known to be excreted in human milk following systemic administration but excretion in human milk after topical treatment has not been investigated. Although blood concentrations are undetectable after topical administration of RESTASIS™, caution should be exercised when RESTASIS™ is administered to a nursing woman.

**Pediatric Use:**

The safety and efficacy of RESTASIS™ have not been established in pediatric patients.

### **Geriatric Use:**

No overall difference in safety or effectiveness have been observed between elderly and younger patients.

### **ADVERSE REACTIONS**

The most common adverse event following the use of RESTASIS™ was ocular burning (16%). Other events reported in 1% to 3% of patients (in order of decreasing incidence) included ocular stinging/irritation, discharge, foreign body sensation, pruritus, conjunctival hyperemia, photophobia, visual disturbance (blurred vision), headache, eyelid edema, and eye pain (NDA Section 8.7).

### **DOSAGE AND ADMINISTRATION**

The recommended dosage is one drop of RESTASIS™ instilled twice a day in each eye approximately 12 hours apart. RESTASIS™ can be used concomitantly with artificial tears.

Invert the unit dose vial a few times to obtain a uniform, white, opaque emulsion before using.

RESTASIS™ was investigated for up to 12 months during clinical trials for moderate to severe keratoconjunctivitis sicca.

### **HOW SUPPLIED**

RESTASIS™ (cyclosporine ophthalmic emulsion) 0.05% is available as a sterile preservative-free emulsion supplied in vials as follows:

RESTASIS™ 32 Vials 0.4 mL each-NDC XXXX-XXXX-XX

Store RESTASIS™ at 25° C (77° F); excursions permitted to 15°-30° C (59°-86° F). Do not freeze.

**Rx Only**

 **ALLERGAN**

©1999 Allergan, Inc.

Irvine, CA 92612, U.S.A.

## **PATIENT INFORMATION**

**Pharmacist: Please cut or tear at dotted line and provide this patient package insert to your customer.**

**RESTASIS™ (cyclosporine ophthalmic emulsion) 0.05%**

**Sterile, Preservative-Free**

**Please read this leaflet carefully before you start to use your medicine. If you have any questions, or are not sure about anything, ask your doctor or pharmacist.**

### **Introduction**

You are one of millions of people who have a condition called “dry eye.” The medical term for this is keratoconjunctivitis sicca, or KCS. Your doctor has prescribed RESTASIS™ because it has been proven to be an effective way to treat the combination of uncomfortable symptoms and underlying inflammation, which characterize dry eye disease.

The following information will answer many of the questions you may have about your condition or your medicine. It is important that you understand dry eye and the treatment your doctor has prescribed.

### **What are tears?**

There are two kinds of tears: those produced naturally to lubricate and nourish your eyes, and those produced in response to irritation or emotions. Both are necessary for your eyes to function properly.

Natural tears form a film over your eyes to protect them from irritation and keep them moisturized and lubricated. This tear film also contains nutrients that help keep your eyes healthy. Blinking helps spread the tear film over the entire surface of your eyes. Insufficient tear production can lead to redness, pain, and even scarring of the cornea (the transparent part of the eye that covers the pupil and iris.)

### **What is dry eye?**

Dry eye is a reduction in your eyes' ability to produce sufficient natural tears. It results from a chronic underlying inflammatory condition, which affects the glands, and cells that produce tears. Some of the symptoms of dry eye include a burning sensation in the eyes, a persistent gritty feeling in the eyes, decreased tolerance to contact lenses, blurred vision, or sensitivity to light.

### **Who has chronic dry eye?**

It is estimated that about 12 million Americans suffer from chronic dry eye symptoms, including 75% of people over the age of 65. Dry eye can affect men and women, but most susceptible are postmenopausal women and those with arthritis.

### **What causes dry eye?**

As we age, our bodies experience a normal reduction in natural tear production. Additionally, certain diseases and medical conditions, such as arthritis and menopause, can cause chronic dry eye symptoms. Even though the cause of dry eye disease may vary from patient to patient, the underlying inflammatory condition remains the same.

### **Some causes of dry eye are:**

- Hormonal changes associated with aging.
- Arthritis and related conditions.
- Changes in tear composition or quantity due to age or disease.
- Blocked tear ducts.
- Sjogren's Syndrome, an immune disorder characterized by dryness of the mouth, eyes, and other mucous membranes.



### **How is dry eye diagnosed?**

Your eye care professional or eye doctor monitors your overall condition and can check your eyes for signs and symptoms of dry eye disease. When making a diagnosis, he or she may use several tests, the most common of which is called the Schirmer test. Another quick, painless way to measure your tear production is an examination that uses a specially colored eye drop. These tests can aid your doctor in confirming the diagnosis.

### **Why has my doctor prescribed RESTASIS™?**

Your doctor has prescribed RESTASIS™ to treat your dry eye disease. RESTASIS™ relieves your dry eye symptoms by restoring normal tear secretion. RESTASIS™ is a prescription medication and should be used only as directed by your doctor.

### **What is RESTASIS™?**

RESTASIS™ is a prescription medicine for use on the eye only. The active ingredient in RESTASIS™, cyclosporine, is an immunomodulator agent with anti-inflammatory effects when used in patients with dry-eye disease.

### **How do I take RESTASIS™?**

You should use RESTASIS™ twice a day, once in the morning and once at night, or as directed by your doctor. Apply one drop to each eye in the morning and at night.

**IMPORTANT:** Always invert the unit dose vial a few times to obtain a uniform, white, opaque emulsion before using. To avoid contamination, do not touch the tip of the vial to the eye or any surface. Use within 12 hours after opening. It is normal for a small amount of product to remain in the dropper tip. Discard container after use.

### **How long do I need to continue to use RESTASIS™?**

RESTASIS™ is a treatment for the underlying inflammatory mechanism, which may cause the discomfort in chronic dry eye disease. Do not discontinue therapy prematurely. Always discuss any change in your medication schedule with your physician.

**Can I continue to use over-the-counter lubricating eye drops while I am using RESTASIS™?**

Yes, but you may find that you do not require drops as frequently. In fact, you may not need them at all.

**Can I use RESTASIS™ while wearing my contact lenses?**

Contact lenses should be removed from your eyes before applying RESTASIS™. For this reason, it is recommended that RESTASIS™ be applied in the morning (at least 10 minutes before applying your contact lenses) and in the evening (after removing your contact lenses).

**Will RESTASIS™ interact with other systemic medications?**

There is little information regarding the interaction of systemic drugs co-administered with RESTASIS™. Systemic exposure of cyclosporin A from RESTASIS™ is minimal. Therefore, no interaction of topically applied RESTASIS™ with systemic drugs is expected to occur.

**What are the most common side effects reported with RESTASIS™?**

The most common side effect following the use of RESTASIS™ was burning, which was experienced by 16% of patients. Other side effects reported in 1% to 3% of patients (in order of decreasing incidence) include: stinging/irritation, mucous discharge, foreign body sensation, itching, eye redness, sensitivity to light, blurred vision, headache, eyelid swelling and eye pain.

**Who should not use RESTASIS™?**

As with any medication, you should not use RESTASIS™ if you have a known history of hypersensitivity to any of its components. You should also not use RESTASIS™ if you have an eye-infection or if you often suffer from an eye disease called herpes keratitis.

**Instruction for use and handling:**

Always invert the unit dose vial a few times to obtain a uniform, white, opaque emulsion before using. To avoid contamination, do not touch the tip of the vial to the eye or any surface. Use within 12 hours after opening. It is normal for a small amount of product to remain in the dropper tip. Discard container after use. RESTASIS™ should be stored at 25° C (77° F); but short term exposure to 15°-30° C (59°-86° F) is acceptable; do not freeze.

**If you have questions about RESTASIS™:** You may contact Allergan by calling 800-433-8871

Allergan, Irvine, California 92612, USA

February 1999

**References:**

Study Report References:

STUDY NUMBER	STUDY TITLE	VOL	PAGE
192371-001	A dose-ranging study evaluating the safety, tolerability, and efficacy of cyclosporine (0.05, 0.1, 0.2, 0.4%) and vehicle ophthalmic emulsions in the treatment of moderate to severe keratoconjunctivitis sicca. Allergan, 1997.	vol. 27	p. 002
192371-002	A multicenter, double-masked, randomized, vehicle-controlled, parallel-group study of the safety and efficacy of cyclosporine 0.05% and 0.1% ophthalmic emulsions used twice daily for up to one year in patients with moderate to severe keratoconjunctivitis sicca. Allergan, 1998.	vol. 40	p. 001
192371-003	A multicenter, double-masked, randomized, vehicle-controlled, parallel-group study of the safety and efficacy of cyclosporine 0.05% and 0.1% ophthalmic emulsions used twice daily for up to one year in patients with moderate to severe keratoconjunctivitis sicca. Allergan, 1998.	vol. 60	p. 001
NDA Section 8.6	Integrated Summary of Efficacy	vol. 25	p. 063
NDA Section 8.7	Integrated Summary of Safety	vol. 26	p. 001
PK-95-010	Ocular Pharmacokinetics of Cyclosporine after a Single Eyedrop Instillation of a 0.2% <sup>3</sup> H-Cyclosporine Ophthalmic Emulsion into Albino Rabbit Eyes. A. Acheampong, February 1995.	vol. 18	p. 257
PK-96-016	<sup>3</sup> H-Cyclosporine Ocular Absorption and Disposition in Beagle Dogs Following Multiple Ocular Doses of 0.2% <sup>3</sup> H-Cyclosporine Emulsion. Huntingdon Life Sciences, Ltd., October 1996.	vol. 19	p. 100
PK-96-017	<sup>3</sup> H-Cyclosporine Ocular Absorption and Disposition in Beagle Dogs Following Single Ocular Doses of 0.2% <sup>3</sup> H-Cyclosporine Emulsion. Huntingdon Life Sciences, Ltd., October 1996.	vol. 19	p. 194
PK-98-074	Ocular Cyclosporine Distribution During 9 <sup>1</sup> / <sub>2</sub> Days of Dosing of 0.05 and 0.1% <sup>3</sup> H-Cyclosporin A Emulsions to Albino Rabbit Eyes. D. Small, October 1998.	vol. 19	p. 327

STUDY NUMBER	STUDY TITLE	VOL	PAGE
PK-98-109	Six Month Interim Pharmacokinetic Analysis of Trough Blood Concentrations for Study 192371-002 Titled, "A Multicenter, Double-Masked, Randomized, Vehicle-Controlled, Parallel-Group Study of the Safety and Efficacy of Cyclosporine 0.05% and 0.1% Ophthalmic Emulsions Used Twice Daily for Up To One Year in Patients with Moderate to Severe Keratoconjunctivitis Sicca." D. Small, October 1998.	vol. 19 p.	357
PK-98-112	Interim Report of Blood Cyclosporin A Concentrations During One Dosing Interval for Study 192371-002 Titled, "A Multicenter, Double-Masked, Randomized, Vehicle-Controlled, Parallel-Group Study of the Safety and Efficacy of Cyclosporine 0.05% and 0.1% Ophthalmic Emulsions Used Twice Daily for Up To One Year in Patients with Moderate to Severe Keratoconjunctivitis Sicca." D. Small, October 1998.	vol. 19 p.	371
Tertiary Report: IL-6	Investigator Summary Report of Tertiary Tests of Inflammatory Cytokine Interleukin-6 (Protocol 192371-003). S Pflugfelder (University of Miami), 1999.	vol. 85 p.	016
Tertiary Report: Conjunctival Biopsies	Investigator Summary Report of Tertiary Tests of Conjunctival Biopsies (Protocols 192371-002 and 192371-003). IK Gipson (Schepens Eye Research Institute), 1999	vol. 85 p.	029
Tertiary Report: Goblet Cell Density	Investigator Summary Report of Tertiary Tests of Conjunctival Goblet Cell Density (Protocols 192371-002 and 192371-003). AJ Bron (University of Oxford), 1999.	vol. 85 p.	072

## Literature References:

AUTHOR	TITLE	VOL PAGE
Baudoin et al, 1997	Baudouin C, Brignole F, Becquet F, et al. Flow cytometry in impression cytology specimens. A new method for evaluation of conjunctival inflammation. Invest Ophthalmol Vis Sci 1997; 38:1458-1464.	vol. 86 p. 020
Belin et al, 1990	Belin MW, Bouchard CS, Phillips TM. Update on topical cyclosporin A: background, immunology, and pharmacology. Cornea 1990; 9:184-195.	vol. 86 p. 034
Borel et al, 1996	Borel JF, Baumann G, Chapman I, Donatsch P, et al. In Vivo pharmacological effects of ciclosporin and some analogues. Adv Pharmacol 1996:115-246.	vol. 86 p. 068
Boss et al, 1998	Boss V, Wang X, Koppelman LF, et al. Histamine induces nuclear factor of activated T cell-mediated transcription and cyclosporin A-sensitive interleukin-8 mRNA expression in human umbilical vein endothelial cells. Mol Pharmacol 1998; 54:264-72.	vol. 86 p. 200
Gao et al, 1998	Gao J, Schwalb TA, Addeo JV, et al. The role of apoptosis in the pathogenesis of canine Keratoconjunctivitis Sicca: The effect of topical cyclosporin A therapy. Cornea 1998;17(6):654-63	vol. 86 p. 303
Jones et al, 1994	Jones DT, Monroy D, Ji Z, et al. Sjogren's syndrome: cytokine and Epstein -Barr viral gene within the conjunctival epithelium. Invest Ophthalmol Vis Sci 1994; 35:3493-504.	vol. 87 p. 115
Kahan et al, 1983	Kahan BD, Van Buren CT, Flechner SM, et al. Cyclosporine immunosuppression mitigates immunologic risk factors in renal allotransplantation. Transplant Proc 1983; 15:2469-2478.	vol. 87 p. 127
Kahan, 1989	Kahan BD. Drug Therapy. Cyclosporine. New Eng J Med 1989; 321:1725-38.	vol. 87 p. 137
Kahan, 1994	Kahan BD. New immunosuppressive drugs - pharmacologic approaches to alter immunoregulation. Ther Immunol 1994;1:33-44.	vol. 87 p. 151
Meyer et al, 1997	Meyer S, Kohler G, Joly A, et al. Cyclosporine A is an uncompetitive inhibitor of proteasome activity and prevents NF- $\kappa$ B activation. FEBS Letters 1997;41(3):354-8.	vol. 87 p. 330

AUTHOR	TITLE	VOL PAGE
Mitruka et al, 1998	Mitruka SN, Pham SM, Zeevi A, et al. Aerosol cyclosporine prevents acute allograft rejection in experimental lung transplantation. J Thorac Cardiovasc Surg 1998; 115:28-36.	vol. 87 p. 344
Pette et al, 1997	Pette M, Pette DF, Muraro PA, et al. In vitro modulation of human, auto reactive MBP-specific CD4+ T cell clones by cyclosporin A. J Neuroimmunol 1997; 76:91-9.	vol. 88 p. 153
Schliephake et al, 1997	Schliephake H, Redecker K, Schmelzeisen R, et al. Cytokines and cytokine receptors in mouth mucosa of immune suppressed patients. Mund Kiefer Gesichtschir 1997; 192:111-4.	vol. 88 p. 317
Scorrano et al, 1997	Scorrano L, Nicolli A, Basso E, et al. Two modes of activation of the permeability transition pore: The role of mitochondrial cyclophilin. Mol Cell Biochem 1997; 174:181-4.	vol. 88 p. 321
Stern et al, 1998	Stern ME, Beuerman RW, Fox RI, et al. The pathology of dry eye: The interaction between the ocular surface and the lacrimal glands. Cornea 1998;17(6):584-9.	vol. 89 p. 005
Svecova et al, 1998	Svecova D, Kawashima T, Ohkawara A. IL-8 production by TYP-1 monocytic cell line is adversely regulated by cyclosporin and retinoic acid. Bratisl Lek Listy 1998; 99:48-53.	vol. 89 p. 046
van der Pouw Kraan et al, 1996	van der Pouw Kraan TC, Boeijs LC, Troon JT, et al. Human IL-13 production is negatively influenced by CD3 engagement. Enhancement of IL-13 production by cyclosporin A. J Immunol 1996; 156:1818-23.	vol. 89 p. 046
PDR-NEORAL®	NEORAL® Soft Gelatin Capsules and NEORAL® Oral Solution. Physicians' Desk Reference 1998; 1882-9.	vol. 88 p. 103

**Z.2 DRAFT  
LABELING**





## RESTASIS™

(cyclosporine ophthalmic emulsion) 0.05%

Sterile, Preservative-Free

### DESCRIPTION

RESTASIS™ (cyclosporine ophthalmic emulsion) 0.05% is an immunomodulator with anti-inflammatory effects when used in patients with dry-eye disease. Cyclosporine's chemical name is Cyclo[[*(E)*-(2*S*,3*R*,4*R*)-3-hydroxy-4-methyl-2-(methylamino)-6-octenoyl]-L-2-aminobutyryl-*N*-methylglycyl-*N*-methyl-L-leucyl-L-valyl-*N*-methyl-L-leucyl-L-alanyl-D-alanyl-*N*-methyl-L-leucyl-*N*-methyl-L-leucyl-*N*-methyl-L-valyl] and it has the following structure:

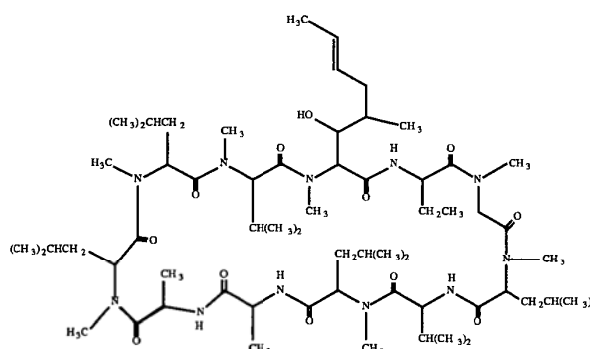

Formula:  $C_{62}H_{111}N_{11}O_{12}$  Mol. Wt.: 1202.6

Cyclosporine is a fine white powder. RESTASIS™ appears as a white opaque to slightly translucent homogeneous emulsion. It has an Osmolality of 240 to 280 mOsmol/kg and a pH of 7.0-7.8.

Each mL of RESTASIS™ contains: Active ingredient: cyclosporine 0.05%. Inactives: carbomer 1342; castor oil; glycerin; polysorbate 80; sodium hydroxide to adjust the pH; and purified water.

## CLINICAL PHARMACOLOGY

### Mechanism of action:

In dry-eye disease, cyclosporine emulsion acts as a potent, but selective immunomodulator, an anti-inflammatory agent, and a direct inhibitor of pathological epithelial apoptosis.

#### Immunomodulation:

Cyclosporine leaves critical functions of host immunity intact. Only the early stages of T-cell activation (helper T-cells) and not the lymphocytic effector stages responsible for elimination of intruder cells are suppressed.

Topical cyclosporine emulsion achieves its immunomodulatory activity by inhibiting the activation of NF- $\kappa$ B, a nuclear factor involved in the regulation of immune and pro-inflammatory cytokine response genes, such as TNF, IL-1, IL-2, and IL-8.

#### Anti-inflammatory:

Helper T cells identified in the tissues of the ocular surface and lacrimal glands play an important role not only in the immune response, but also in the inflammatory response through cytokine synthesis. Cyclosporine prevents the synthesis and/or secretion of several pro-inflammatory cytokines. It is also known to upregulate secretion of anti-inflammatory cytokines.

#### Inhibition of pathological apoptosis:

Inflammatory conditions can direct pathological apoptosis of secretory acinar epithelial cells and facilitate accumulation of lymphocytic infiltrates within the lacrimal glands and conjunctival epithelium. These events result in loss of normal glandular structure and its secretory function. Cyclosporine has been reported to be a direct inhibitor of pathological apoptosis of acinar epithelium cells and has been shown to reverse pathological acinar apoptosis and lymphocyte proliferation in dry eye dogs.

### **Pharmacokinetics:**

Blood cyclosporin A concentrations were measured using a specific high pressure liquid chromatography-mass spectrometry assay. Blood concentrations of cyclosporine A, in all the samples collected, after topical administration of RESTASIS™ 0.05%, BID, in humans for up to 12 months, were below the quantitation limit of 0.1 ng/mL. These levels are more than 6550 times lower than those measured during systemic cyclosporine treatment for non-life-threatening indications. There was no detectable drug accumulation in blood during 12 months of treatment with RESTASIS™. As a result of these findings no renal or hepatic cytotoxicity would be expected to occur following the use of RESTASIS™.

Maximal concentrations obtained from rabbit and dog studies indicate that the great majority of drug contained in ocular tissues after ophthalmic administration resides in the outer layers of the eye, and that little penetrates to the interior. High concentrations and long half-lives in ocular surface tissues suggest that these tissues act as a reservoir for cyclosporine, sequestering cyclosporine and releasing it slowly over prolonged periods. Half-lives in conjunctiva, cornea and sclera after multiple ophthalmic doses to albino rabbits ranged from 32 to 52 hours. Half-lives in beagle dogs after multiple ophthalmic doses were also longer than 24 hours.

Cyclosporine is not metabolized by ocular tissues in albino rabbits.

### **Clinical Evaluations:**

RESTASIS™ achieved clinically and statistically significant results versus vehicle for the individual parameters corneal staining, blurred vision, categorized Schirmer with anesthesia, and reduction in artificial tear use. Improvement from baseline with RESTASIS™ was seen in virtually all efficacy parameters. In addition no bacterial or fungal ocular infections were reported following administration of RESTASIS™.

Results of additional tests performed in the clinical trial following 6 months of treatment showed that RESTASIS™ reduces the inflammation, immune reactivity underlying KCS and improves ocular surface health and tear film in dry-eye patients with and without Sjögren's syndrome.

Inflammatory cytokine IL-6 levels in the conjunctival epithelium showed a statistically significant decrease from baseline. Conjunctival biopsies showed: the immune activation marker HLA-DR decreased 34% compared to a 160% increase with vehicle, the inflammation marker CD11a decreased 11% compared to a 104% increase with vehicle, CD3 (total T cells) and CD8 (T suppressor cells) decreased compared to an increase with vehicle, goblet cell density increased 191% compared to an increase of only 13% with vehicle.

## **INDICATIONS AND USAGE**

RESTASIS™ is indicated for the treatment of moderate to severe keratoconjunctivitis sicca; it restores and maintains normal tear secretion and ocular surface integrity while providing relief of symptoms associated with dry-eye.

## **CONTRAINDICATIONS**

RESTASIS™ is contraindicated in patients with active, ocular infection and in patients with previously demonstrated hypersensitivity to any of the ingredients in the formulation.

## **WARNING**

RESTASIS™ has not been studied in patients with a history of recurrent herpes keratitis.

## **PRECAUTIONS**

### **Information for Patients:**

To avoid contamination, do not touch the tip of the vial to the eye or any other surface. Use the contents of the vial within 12 hours after opening and discard. RESTASIS™ should not be administered while wearing contact lenses. Patients should be advised not to discontinue therapy prematurely. Also refer to attached patient information.

### **Drug Interactions:**

There is little information regarding the interaction of ophthalmic drugs co-administered with topical ophthalmic cyclosporine. Systemic exposure of cyclosporin A from RESTASIS™ is minimal. Therefore, no interaction of topically applied RESTASIS™ with systemic drugs is expected to occur.

### **Carcinogenesis, Mutagenesis, and Impairment of Fertility:**

Systemic carcinogenicity studies were carried out in male and female mice and rats. In the 78-week oral (diet) **mouse** study, at doses of 1, 4, and 16 mg/kg/day, evidence of a statistically significant trend was found for lymphocytic lymphomas in females, and the incidence of hepatocellular carcinomas in mid-dose males significantly exceeded the control value.

In the 24-month oral (diet) **rat** study, conducted at 0.5, 2, and 8 mg/kg/day, pancreatic islet cell adenomas significantly exceeded the control rate in the low dose level. The hepatocellular carcinomas and pancreatic islet cell adenomas were not dose related. The low doses in mice and rats are approximately 1000 and 500 times greater, respectively, than the daily human dose of one drop (35 µL) of RESTASIS™ BID into each eye (0.001 mg/kg), assuming that the entire dose is absorbed.

Cyclosporine has not been found mutagenic/genotoxic in the Ames Test, the V79-HGPRT Test, the micronucleus test in mice and Chinese hamsters, the chromosome-aberration tests in Chinese hamster bone-marrow, the mouse dominant lethal assay, and the DNA-repair test in sperm from treated mice. A recent study analyzing sister chromatid exchange (SCE) induction by cyclosporine using human lymphocytes *in vitro* gave indication of a positive effect (i.e., induction of SCE), at high concentrations in this system.

No impairment in fertility was demonstrated in studies in male and female rats.

**Pregnancy:**

Pregnancy Category: B

Teratogenic effects: Cyclosporine was found to be non-teratogenic in appropriate test systems. Rats at up to 17 mg/kg/day and rabbits at up to 30 mg/kg/day, dosed with cyclosporine oral solution, USP proved to be without any embryolethal or teratogenic.

These doses in rats and rabbits are approximately 17,000 and 30,000 times greater, respectively, than the daily human dose of one drop (35 µl) RESTASIS™ BID into each eye (0.001 mg/kg), assuming that the entire dose is absorbed.

Non-Teratogenic effects: Adverse effects were seen in reproduction studies in rats only at dose levels toxic to dams. At toxic doses (rats at 30 mg/kg/day and rabbits at 100 mg/kg/day), cyclosporine oral solution, USP, was embryo- and fetotoxic as indicated by increased pre- and postnatal mortality and reduced fetal weight together with related skeletal retardations. These doses are 30,000 times and 100,000 times greater, respectively than the daily human dose of one-drop (35 µl) of RESTASIS™ BID into each eye (0.001 mg/kg), assuming that the entire dose is absorbed.

There are no adequate and well-controlled studies of RESTASIS™ in pregnant women. RESTASIS™ should be administered to a pregnant woman only if clearly needed.

**Nursing Mothers:**

Cyclosporine is known to be excreted in human milk following systemic administration but excretion in human milk after topical treatment has not been investigated. Although blood concentrations are undetectable after topical administration of RESTASIS™, caution should be exercised when RESTASIS™ is administered to a nursing woman.

### **Pediatric Use:**

The safety and efficacy of RESTASIS™ have not been established in pediatric patients.

### **Geriatric Use:**

No overall difference in safety or effectiveness have been observed between elderly and younger patients.

### **ADVERSE REACTIONS**

The most common adverse event following the use of RESTASIS™ was ocular burning (16%). Other events reported in 1% to 3% of patients (in order of decreasing incidence) included ocular stinging/irritation, discharge, foreign body sensation, pruritus, conjunctival hyperemia, photophobia, visual disturbance (blurred vision), headache, eyelid edema, and eye pain.

### **DOSAGE AND ADMINISTRATION**

The recommended dosage is one drop of RESTASIS™ instilled twice a day in each eye approximately 12 hours apart. RESTASIS™ can be used concomitantly with artificial tears.

Invert the unit dose vial a few times to obtain a uniform, white, opaque emulsion before using. RESTASIS™ was investigated for up to 12 months during clinical trials for moderate to severe keratoconjunctivitis sicca.

### **HOW SUPPLIED**

RESTASIS™ (cyclosporine ophthalmic emulsion) 0.05% is available as a sterile preservative-free emulsion supplied in vials as follows:

RESTASIS™ 32 Vials 0.4 mL each-NDC XXXX-XXXX-XX

Store RESTASIS™ at 25° C (77° F); excursions permitted to 15°-30° C (59°-86° F). Do not freeze.

**Rx Only**

 **ALLERGAN**

©1999 Allergan, Inc.

Irvine, CA 92612, U.S.A.

**PATIENT INFORMATION**

**Pharmacist: Please cut or tear at dotted line and provide this patient package insert to your customer.**

**RESTASIS™ (cyclosporine ophthalmic emulsion) 0.05%**

**Sterile, Preservative-Free**

**Please read this leaflet carefully before you start to use your medicine. If you have any questions, or are not sure about anything, ask your doctor or pharmacist.**

**Introduction**

You are one of millions of people who have a condition called “dry eye.” The medical term for this is keratoconjunctivitis sicca, or KCS. Your doctor has prescribed RESTASIS™ because it has been proven to be an effective way to treat the combination of uncomfortable symptoms and underlying inflammation, which characterize dry eye disease.

The following information will answer many of the questions you may have about your condition or your medicine. It is important that you understand dry eye and the treatment your doctor has prescribed.

**What are tears?**

There are two kinds of tears: those produced naturally to lubricate and nourish your eyes, and those produced in response to irritation or emotions. Both are necessary for your eyes to function properly.



Natural tears form a film over your eyes to protect them from irritation and keep them moisturized and lubricated. This tear film also contains nutrients that help keep your eyes healthy. Blinking helps spread the tear film over the entire surface of your eyes. Insufficient tear production can lead to redness, pain, and even scarring of the cornea (the transparent part of the eye that covers the pupil and iris.)

### **What is dry eye?**

Dry eye is a reduction in your eyes' ability to produce sufficient natural tears. It results from a chronic underlying inflammatory condition, which affects the glands, and cells that produce tears. Some of the symptoms of dry eye include a burning sensation in the eyes, a persistent gritty feeling in the eyes, decreased tolerance to contact lenses, blurred vision, or sensitivity to light.

### **Who has chronic dry eye?**

It is estimated that about 12 million Americans suffer from chronic dry eye symptoms, including 75% of people over the age of 65. Dry eye can affect men and women, but most susceptible are postmenopausal women and those with arthritis.

### **What causes dry eye?**

As we age, our bodies experience a normal reduction in natural tear production. Additionally, certain diseases and medical conditions, such as arthritis and menopause, can cause chronic dry eye symptoms. Even though the cause of dry eye disease may vary from patient to patient, the underlying inflammatory condition remains the same.

### **Some causes of dry eye are:**

- Hormonal changes associated with aging.
- Arthritis and related conditions.
- Changes in tear composition or quantity due to age or disease.
- Blocked tear ducts.

- Sjogren's Syndrome, an immune disorder characterized by dryness of the mouth, eyes, and other mucous membranes.

### **How is dry eye diagnosed?**

Your eye care professional or eye doctor monitors your overall condition and can check your eyes for signs and symptoms of dry eye disease. When making a diagnosis, he or she may use several tests, the most common of which is called the Schirmer test. Another quick, painless way to measure your tear production is an examination that uses a specially colored eye drop. These tests can aid your doctor in confirming the diagnosis.

### **Why has my doctor prescribed RESTASIS™?**

Your doctor has prescribed RESTASIS™ to treat your dry eye disease. RESTASIS™ relieves your dry eye symptoms by restoring normal tear secretion. RESTASIS™ is a prescription medication and should be used only as directed by your doctor.

### **What is RESTASIS™?**

RESTASIS™ is a prescription medicine for use on the eye only. The active ingredient in RESTASIS™, cyclosporine, is an immunomodulator agent with anti-inflammatory effects when used in patients with dry-eye disease.

### **How do I take RESTASIS™?**

You should use RESTASIS™ twice a day, once in the morning and once at night, or as directed by your doctor. Apply one drop to each eye in the morning and at night.

**IMPORTANT:** Always invert the unit dose vial a few times to obtain a uniform, white, opaque emulsion before using. To avoid contamination, do not touch the tip of the vial to the eye or any surface. Use within 12 hours after opening. It is normal for a small amount of product to remain in the dropper tip. Discard container after use.

**How long do I need to continue to use RESTASIS™?**

RESTASIS™ is a treatment for the underlying inflammatory mechanism, which may cause the discomfort in chronic dry eye disease. Do not discontinue therapy prematurely. Always discuss any change in your medication schedule with your physician.

**Can I continue to use over-the-counter lubricating eye drops while I am using RESTASIS™?**

Yes, but you may find that you do not require drops as frequently. In fact, you may not need them at all.

**Can I use RESTASIS™ while wearing my contact lenses?**

Contact lenses should be removed from your eyes before applying RESTASIS™. For this reason, it is recommended that RESTASIS™ be applied in the morning (at least 10 minutes before applying your contact lenses) and in the evening (after removing your contact lenses).

**Will RESTASIS™ interact with other systemic medications?**

There is little information regarding the interaction of systemic drugs co-administered with RESTASIS™. Systemic exposure of cyclosporin A from RESTASIS™ is minimal. Therefore, no interaction of topically applied RESTASIS™ with systemic drugs is expected to occur.

**What are the most common side effects reported with RESTASIS™?**

The most common side effect following the use of RESTASIS™ was burning, which was experienced by 16% of patients. Other side effects reported in 1% to 3% of patients (in order of decreasing incidence) include: stinging/irritation, mucous discharge, foreign body sensation, itching, eye redness, sensitivity to light, blurred vision, headache, eyelid swelling and eye pain.

**Who should not use RESTASIS™?**

As with any medication, you should not use RESTASIS™ if you have a known history of hypersensitivity to any of its components. You should also not use RESTASIS™ if you have an eye-infection or if you often suffer from an eye disease called herpes keratitis.

**Instruction for use and handling:**

Always invert the unit dose vial a few times to obtain a uniform, white, opaque emulsion before using. To avoid contamination, do not touch the tip of the vial to the eye or any surface. Use within 12 hours after opening. It is normal for a small amount of product to remain in the dropper tip. Discard container after use. RESTASIS™ should be stored at 25° C (77° F); but short term exposure to 15°-30° C (59°-86° F) is acceptable; do not freeze.

**If you have questions about RESTASIS™:** You may contact Allergan by calling 800-433-8871

Allergan, Irvine, California 92612, USA

February 1999

**Tray Label:**

**RESTASIS™**

(cyclosporine ophthalmic emulsion) 0.05%

Sterile, Preservative-Free

Each mL contains:

Active: cyclosporine 0.05%

Inactives: carbomer 1342; castor oil; glycerin; polysorbate 80; sodium hydroxide to adjust the pH; and purified water.

Usual Dosage: Twice daily approximately 12 hours apart. Use vial within 12 hours of opening, then discard.

32 Vials 0.4 mL each

NDC XXXX-XXXX-XX Bar Code

Note: Store at 25° C (77° F); excursions permitted to 15°-30° C (59°-86° F). Do not freeze.

Lot # & Exp. Date

**Rx Only**

©Allergan

Irvine, CA 92612, U.S.A.

**Vial Labeling:**

**Front Label:**

RESTASIS™

(cyclosporine ophthalmic emulsion) 0.05%

**Back Imprint:**

Allergan, Inc.

Irvine, CA 92612

Lot # & Exp. Date



<b>Section 3</b>	<b>Vol.</b>	<b>Page</b>
Section 3 SUMMARY .....	1	192
3.1 PHARMACOLOGIC CLASS, SCIENTIFIC RATIONALE, INTENDED USE, AND POTENTIAL CLINICAL BENEFITS .....	1	192
3.1.1 PHARMACOLOGIC CLASS .....	1	192
3.1.2 SCIENTIFIC RATIONALE .....	1	192
3.1.3 INTENDED USE .....	1	194
3.1.4 POTENTIAL CLINICAL BENEFITS .....	1	195
3.1.5 REFERENCES .....	1	197
3.1.5.1 Study Report References .....	1	197
3.1.5.2 Literature References .....	1	199
3.2 FOREIGN MARKETING HISTORY .....	1	202
3.2.1 COUNTRIES WHERE THE DRUG HAS BEEN MARKETED ..	1	202
3.2.2 COUNTRIES WHERE THE DRUG HAS BEEN WITHDRAWN FROM MARKETING .....	1	202
3.2.3 COUNTRIES WHERE MARKETING APPLICATIONS ARE PENDING .....	1	202
3.3 CHEMISTRY, MANUFACTURING AND CONTROLS SUMMARY	1	203
3.3.1 ACTIVE PHARMCEUTICAL INGREDIENT .....	1	204
3.3.2 DRUG PRODUCT .....	1	204
3.3.2.1 Quantitative Composition .....	1	204
3.3.2.2 Container-Closure System .....	1	205
3.3.2.2.1 Schematic .....	1	206
3.3.2.2.1 Qualification of Container and Closures .....	1	208
3.3.2.3 Product Tests, Specifications, and Analytical Methods .....	1	210
3.3.2.3.1 Rationale for Drug Product Specifications: .....	1	211
3.3.2.3.2 Rationale for Analytical Tests for Drug Product: .....	1	212
3.3.2.3.3 Stability .....	1	216
3.3.6 CORRELATION OF DRUG SUBSTANCE LOTS USED IN CLINICAL, TOXICOLOGY, AND PRODUCT STABILITY LOTS ..	1	216
Table 3.3.6-1 Active Pharmaceutical Ingredient Lots Used in Clinical and Non-Clinical Studies .....	1	217
Table 3.3.6-2 Formulations Used in Non-Clinical Studies .....	1	222
3.4 NONCLINICAL SUMMARY .....	1	223
3.4.1 PHARMACOLOGY .....	1	223
3.4.2 TOXICOLOGY .....	1	224
3.4.3 PHARMACOKINETICS .....	1	225



3.5 CLINICAL PHARMACOKINETICS SUMMARY.....	1	226
3.5.1 SYSTEMIC EXPOSURE AFTER OPHTHALMIC ADMINISTRATION.....	1	226
Table 3.5.1-1. Comparison of dose and subsequent mean blood Cmax, Coverage, Cmin, and AUC0-12 between systemic therapeutic use of NEORAL® and topical use of 0.05% and 0.1% cyclosporine emulsions.....	1	227
3.5.2 OCULAR PHARMACOKINETICS AFTER OPHTHALMIC ADMINISTRATION.....	1	227
3.6 MICROBIOLOGY SUMMARY.....	1	228
3.7 CLINICAL SUMMARY.....	1	229
3.7.1 CLINICAL PHARMACOLOGY AND PHARMACOKINETICS	1	229
3.7.1.1 Background.....	1	229
3.7.1.2 Assessment of Immune Activation and Inflammatory Response.....	1	229
3.7.1.3 Ocular Surface Inflammation.....	1	230
3.7.1.4 Pharmacologic Activity.....	1	231
3.7.1.5 Conclusions.....	1	233
3.7.1.6 References.....	1	233
3.7.2 OVERVIEW OF CLINICAL STUDIES.....	1	236
3.7.2.1 Introduction.....	1	236
3.7.2.2 Design of the Phase 3 Clinical Trials.....	1	236
3.7.2.3 FDA/Sponsor Discussions.....	1	240
3.7.2.5 References.....	1	242
3.7.3 CONTROLLED CLINICAL STUDIES.....	1	243
3.7.3.1 Introduction.....	1	243
3.7.3.2 Tabular Presentation of Studies.....	1	243
3.7.3.3 Phase 2 Dose-Response Study.....	1	247
3.7.3.4 Phase 3 Study Design.....	1	252
3.7.3.5 Phase 3 Patient Disposition and Demographics.....	1	254
3.7.3.6 Phase 3 Intent-to-Treat Analysis of Efficacy Results.....	1	255
3.7.3.7 Results of Phase 3 Tertiary Ophthalmic Tests.....	1	263
3.7.3.8 Phase 3 Pharmacokinetics Results.....	1	267
3.7.3.9 Phase 3 Safety Results.....	1	267
3.7.3.10 Dose and Regimen Rationale.....	1	270
3.7.3.11 Discussion.....	1	271
3.7.3.12 Conclusions.....	1	275

3.7.3.13 References . . . . .	1	277
3.7.4 OTHER STUDIES AND INFORMATION . . . . .	1	281
3.7.5 SAFETY SUMMARY GENERAL SAFETY CONCLUSIONS . .	1	282
3.7.5.1 Extent of Exposure . . . . .	1	282
3.7.5.2 Demographics and Other Patient Characteristics . . . . .	1	284
3.7.5.3 Adverse Events . . . . .	1	284
3.7.5.4 Laboratory Data . . . . .	1	290
3.7.5.5 Other Safety Assessments . . . . .	1	291
3.7.5.6 Drug-Drug Interactions . . . . .	1	292
3.7.5.7 Drug Abuse and Overdosage . . . . .	1	293
3.7.5.8 Safety Information from Other Sources . . . . .	1	293
3.7.5.9 Discussion . . . . .	1	294
3.7.5.10 Conclusions . . . . .	1	297
3.7.5.11 References . . . . .	1	298
3.8 DISCUSSION OF THE BENEFIT/RISK RELATIONSHIP AND PROPOSED ADDITIONAL STUDIES . . . . .	1	304
3.8.1 BENEFIT/RISK ASSESSMENT OF CYCLOSPORINE OPHTHALMIC EMULSION IN THE TREATMENT OF DRY.EYE .	1	304
3.8.1.1 Benefits . . . . .	1	304
3.8.1.2 Risks . . . . .	1	306
3.8.1.3 Conclusions . . . . .	1	308
3.8.2 PROPOSED POST-MARKETING CLINICAL STUDIES OR SURVEILLANCE . . . . .	1	309
3.8.3 REFERENCES . . . . .	1	310
3.8.3.1 Study Report References . . . . .	1	310
3.8.3.2 Literature References . . . . .	1	312

**3.1  
PHARMACOLOGIC  
CLASS**

### 3.1 PHARMACOLOGIC CLASS, SCIENTIFIC RATIONALE, INTENDED USE, AND POTENTIAL CLINICAL BENEFITS

#### 3.1.1 PHARMACOLOGIC CLASS

Cyclosporine emulsion for use in treating dry eye is an ophthalmic preparation that acts as an immunomodulator and an anti-inflammatory agent. Systemic treatment of rheumatoid arthritis and psoriasis patients with oral cyclosporine (2.5 to 5 mg/kg/day) produced blood concentrations (mean  $\pm$  standard deviation) that ranged from a trough of  $74.9 \pm 46.7$  ng/mL to a  $C_{\max}$  of  $655 \pm 186$  to  $728 \pm 263$  ng/mL (PDR - NEORAL<sup>®</sup>, 1998). In contrast, topical cyclosporine emulsion (1 to 2  $\mu$ g/kg/day) produced mean blood trough cyclosporin A concentrations and  $C_{\max}$  values of less than 0.1 ng/mL (study reports PK-96-018, 1996; PK-98-109, 1998; PK-98-112, 1998). These concentrations are at least 749 to 6,550 times lower than the trough and  $C_{\max}$  values seen with systemic therapeutic use. In 98.2% (544/554) of the analyzed samples, blood concentrations following topical ophthalmic administration of cyclosporine were below the assay's quantitation limit of 0.1 ng/mL. All 10 quantifiable samples were from patients receiving 0.1% cyclosporine emulsion; in no patient was the blood cyclosporin A concentration greater than 0.299 ng/mL. Comparison of trough blood cyclosporin A concentrations during multiple ocular dosing indicated no detectable accumulation (NDA Section 3.5).

After ocular administration, these low blood concentrations do not inhibit the body's ability to mount a T-cell mediated response against systemic exogenous antigens as evidenced by the lack of opportunistic ocular infections found in animals (study reports 1793-2936-5, 1995; 1793-2936-6, 1996; CHV-985-126, 1997) and humans (study reports 192371-001, 1997; 192371-002, 1999; 192371-003, 1999). Thus, topical cyclosporine emulsion is thought to exert its therapeutic ophthalmic effect because of local rather than systemic immunosuppression, an action that is termed immunomodulatory.

#### 3.1.2 SCIENTIFIC RATIONALE

Cyclosporine ophthalmic emulsion therapy is directed at keratoconjunctivitis sicca (KCS) patients, with or without Sjögren's syndrome. The active component of the formulation, cyclosporine, is expected to benefit patients through its ability to modulate both the immune reactivity as well as the inflammatory processes.

In the normal individual, tear secretion is controlled via a neural reflex. Stimulation of the ocular surface induces afferent nerve traffic to the central nervous system where it is integrated, and results in efferent nerve traffic to the lacrimal glands. In the lacrimal gland, neural stimulation produces cellular water movement and tear secretion. The lacrimal glands are maintained in an anti-inflammatory state by circulating steroid hormones (Sullivan, 1994). Under normal conditions, trafficking immune cells (eg, T cells) migrate through the lacrimal glands and ocular surface tissues in an inactivated state as part of the body's routine immunovigilance. These immunovigilant T cells undergo a normal apoptotic cell death as they exit the glands and travel toward local lymph nodes (Gao et al, 1998). Under these conditions, the ocular apparatus is in a state of immunoquiescence and homeostasis is maintained.

In individuals with low levels of circulating steroid hormones (eg, KCS patients), the normal anti-inflammatory environment is compromised. The absence of these supportive hormones allows local autoimmunity to develop and a chronic disease state occurs within the eye. This results in a repetitive cycle of inflammation and immune reactivity. Chronic nerve traffic to the lacrimal glands is now theorized to initiate a neurogenic inflammation within the gland. Migrating T cells are activated, and do not undergo normal apoptosis (Gao et al, 1998). Along with acinar epithelial cells, they secrete pro-inflammatory cytokines, leading to inflammation of the lacrimal gland and ocular surface. This inflammation and T-cell infiltration result in glandular dysfunction and dry eye.

Cyclosporine, as an immunomodulating agent, has been shown to break the cycle of the immune reactivity underlying the disease both in dry-eye dogs (Kaswan et al, 1989; Stern et al, 1998) and in dry-eye patients (Power et al, 1993). Cyclosporine reduces lacrimal gland lymphocytic infiltrates and improves tear production in KCS dogs (Kaswan et al, 1989; Kaswan and Salisbury, 1990; Morgan and Abrams, 1991; Olivero et al, 1991) and in KCS patients with or without Sjögren's syndrome (study report 192371-001, 1997; Drosos et al, 1986; Laibovitz et al, 1993; Power et al, 1993; Stern et al, 1998). Power et al demonstrated that patients with secondary Sjögren's disease are undergoing continued immune reactivity, indicated by the presence of significantly more CD4 (T-helper) cells than age/sex-matched controls. Following treatment with topical cyclosporine, there was a significant reduction in the number of CD4 cells in both the conjunctival epithelium and substantia propria, indicating immunopathological improvement.

Through dual activities as an anti-inflammatory agent and immunomodulator, cyclosporine reduces ocular surface inflammation and facilitates restoration of the tear-secreting reflex. Cyclosporine acts by blocking the production of interleukin-2 (IL-2), a key cytokine needed for the regulation and amplification of an immune event. Through a decrease in IL-2 and other cytokines, cyclosporine prevents the recruitment of additional T cells and activation of vigilant T cells within the ocular tissue. Thus, the lacrimal gland in tear-deficient dry eye, no longer under attack by immune processes, can begin to repair and function again in tear production. The inflamed ocular surface tissue can return to a more healthy, non-irritated state.

Cyclosporine emulsion is thought to be effective because of its local immunomodulatory effect rather than effects resulting from systemic absorption (Power et al, 1993). Blood concentrations following topical ophthalmic administration are far below levels required for systemic immunosuppression (study reports PK-96-018, 1996; PK-98-109, 1998; PK-98-112, 1998).

### 3.1.3 INTENDED USE

The intended use for cyclosporine ophthalmic emulsion is treatment for moderate to severe KCS patients, with or without Sjögren's syndrome. KCS, commonly referred to as dry eye, affects the ocular surface, the tear film, and related ocular tissues and organs.

Demographic studies indicate that KCS affects millions of people worldwide; up to 11% of people aged 30 to 60 years (Bjerrum, 1997) and up to 14.6% of people aged 65 years and older (Schein et al, 1997). Patients with dry-eye disease typically complain of symptoms of ocular discomfort, including a dry, gritty feeling, that is often accompanied by foreign body sensation. Burning and irritation, photophobia, blurred vision, and gradual contact lens intolerance can occur, and some patients are unable to cry irritative or emotional tears (Lubniewski and Nelson, 1990). Depending on the duration and severity of disease, damage to the ocular surface may be present and those with chronic, uncontrolled disease have an increased risk of ocular infections (Lemp and Chacko, 1997; Lubniewski and Nelson, 1990).

Dry-eye disease can be a severe, debilitating, and sight-threatening disease. Patients with moderate to severe dry eyes wake up every morning with the feeling of sand and grit in their eyes; during their day every blink and every bright light causes pain. Their quality of life is greatly diminished because their eyes are frequently sore and irritated. They are unable to tolerate dry climates and air conditioning and are embarrassed if they need to wear unsightly

goggles. They are further frustrated, along with their physicians, with the hopelessness that there is no satisfactory treatment available.

According to the National Eye Institute (NEI)/Industry Workshop on Clinical Trials in Dry Eyes, dry eye may be classified into 2 types—evaporative and tear-deficient or, more precisely, aqueous-deficient (Lemp, 1995). In dry eye characterized by excessive tear evaporation, the quantity of aqueous fluid from the lacrimal glands is normal and the tear abnormality is due to increased tear evaporation. Evaporative dry eye may be associated with other periocular diseases and disorders including blepharitis, meibomian gland disease, ocular mucin deficiencies, blinking disorders, proptosis associated with thyroid disease, and structural abnormalities of the lids and eye causing exposure of the ocular surface.

Dry eye characterized by aqueous deficiency is further divided into patients with Sjögren's syndrome (a systemic autoimmune disease) and patients without related systemic disease (non-Sjögren's KCS). Both result in immune-based inflammation of the ocular surface (Power et al, 1993; Stern et al, 1998). The histopathological changes of the lacrimal gland in the patients with Sjögren's syndrome consist of lymphocytic infiltration leading to atrophy and destruction of glandular function (Sanders and Graham, 1986). Most cases of lacrimal gland insufficiency, however, cannot be attributed to Sjögren's syndrome.

Williamson et al (1973) and Damato et al (1984) have described the presence of a lymphocytic infiltrate in the lacrimal glands of non-Sjögren's KCS patients. This suggests that the atrophy of the lacrimal gland that occurs in such patients represents a chronic, progressive inflammatory process. A proposed mechanism for this inflammatory process in non-Sjögren's patients is alterations in membrane trafficking of acinar cells leading to the expression of MHC II (major histocompatibility complex class II) molecules capable of triggering a localized autoimmune response (Mircheff et al, 1994). Additionally, lacrimal gland functional alterations and neural feedback loop changes may develop from chronic ocular surface inflammation.

#### 3.1.4 POTENTIAL CLINICAL BENEFITS

Although KCS can be a severe and debilitating disease, current treatment options are palliative, and provide symptomatic relief only without addressing the underlying mechanisms of the disease. In contrast, cyclosporine ophthalmic emulsion improves the signs and symptoms of KCS, and reduces the ocular inflammation and immune reactivity associated with the disease,

thereby providing therapeutic benefit. Systemic exposure from topical administration is minimal, and cyclosporine emulsion is well tolerated without significant local or systemic effects.



### 3.1.5 REFERENCES

#### 3.1.5.1 Study Report References

STUDY NO.	STUDY TITLE	VOLUME PAGE
1793-2936-5	AGN 192371 – cyclosporine ophthalmic emulsion: a three-month ocular and systemic toxicity study with a one-month recovery period in New Zealand white rabbits. Allergan, 1995.	vol. 14 p. 001
1793-2936-6	AGN 192371 – cyclosporine ophthalmic emulsion: a six-month ocular and systemic toxicity study with a two-month recovery period in New Zealand white rabbits. Allergan, 1996.	vol. 15 p. 001
192371-001	A dose-ranging study evaluating the safety, tolerability, and efficacy of cyclosporine (0.05, 0.1, 0.2, 0.4%) and vehicle ophthalmic emulsions in the treatment of moderate to severe keratoconjunctivitis sicca. Allergan, 1997	vol. 15 p. 001
192371-002	A multicenter, double-masked, randomized, vehicle-controlled, parallel-group study of the safety and efficacy of cyclosporine 0.05% and 0.1% ophthalmic emulsions used twice daily for up to one year in patients with moderate to severe keratoconjunctivitis sicca. Allergan, 1999.	vol. 40 p. 001
192371-003	A multicenter, double-masked, randomized, vehicle-controlled, parallel-group study of the safety and efficacy of cyclosporine 0.05% and 0.1% ophthalmic emulsions used twice daily for up to one year in patients with moderate to severe keratoconjunctivitis sicca. Allergan, 1999.	vol. 60 p. 001

STUDY NO.	STUDY TITLE	VOLUME PAGE
CHV-985-126	52-week ocular and systemic study of cyclosporine in dogs with an 8-week recovery period. Corning Hazleton Incorporated, 1997.	vol. 17 p. 001
PK-96-018	Pharmacokinetic analysis of cyclosporin A in human blood for clinical study entitled "A dose-ranging study evaluating the safety, tolerability, and efficacy of cyclosporine (0.05, 0.1, 0.2, 0.4%) and vehicle ophthalmic emulsions in the treatment of moderate to severe keratoconjunctivitis sicca." Allergan, 1996.	vol. 19 p. 284
PK-98-109	Six month interim pharmacokinetic analysis of cyclosporin A in human blood for clinical study entitled, "a multicenter, double-masked, randomized, vehicle-controlled, parallel-group study of the safety and efficacy of cyclosporine 0.05 and 0.1% ophthalmic emulsions used twice daily for up to one year in patients with moderate to severe keratoconjunctivitis sicca. Allergan, 1998.	vol. 19 p. 357
PK-98-112	Interim report of blood cyclosporin A concentrations during one dosing interval for study 192371-002 titled, "A multicenter, double-masked, randomized, vehicle-controlled, parallel-group study of the safety and efficacy of cyclosporine 0.05% and 0.1% ophthalmic emulsions used twice daily for up to one year in patients with moderate to severe keratoconjunctivitis sicca". Allergan, 1998.	vol. 19 p. 371

### 3.1.5.2 Literature References

Bjerrum KB. Keratoconjunctivitis sicca and primary Sjögren's syndrome in a Danish population aged 30-60 years. *Acta Ophthalmol Scand* 1997;75:281-286. [vol. 86 p. 056]

Damato BE, Allan D, Murray SB, et al. Senile atrophy of the human lacrimal gland: the contribution of chronic inflammatory disease. *Br J Ophthalmol* 1984;68:674-680. [vol. 86 p. 250]

Drosos AA, Skopouli FN, Costopoulos JS, et al. Cyclosporin A (CyA) in primary Sjögren's syndrome: a double blind study. *Ann Rheum Dis* 1986;45:732-735. [vol. 86 p. 257]

Gao J, Schwalb TA, Addeo JV, et al. The role of apoptosis in the pathogenesis of canine keratoconjunctivitis sicca: the effect of topical cyclosporin A therapy. *Cornea* 1998;17:654-663. [vol. 86 p. 303]

Kaswan RL, Salisbury MA, Ward DL. Spontaneous canine keratoconjunctivitis sicca. A useful model for human keratoconjunctivitis sicca: treatment with cyclosporine eye drops. *Arch Ophthalmol* 1989;107:1210-1216. [vol. 87 p. 163]

Kaswan RL, Salisbury MA. A new perspective on canine keratoconjunctivitis sicca: treatment with ophthalmic cyclosporine. *Vet Clin North Am Small Anim Pract* 1990;20:583-613. [vol. 87 p. 170]

Laibovitz RA, Solch S, Andriano K, et al. Pilot trial of cyclosporine 1% ophthalmic ointment in the treatment of keratoconjunctivitis sicca. *Cornea* 1993;12:315-323.[vol. 87 p. 228]

Lemp MA. Report of the National Eye Institute/Industry Workshop on Clinical Trials in Dry Eyes. *CLAO J* 1995;21:221-232. [vol. 87 p. 237]

Lemp MA, Chacko B. Diagnosis and treatment of tear deficiencies. In: Tasman W, Jaeger E, eds. *Duane's Clinical Ophthalmology*. Philadelphia: Harper and Row; 1997; chapter 14:1-13 (updated 1991). [vol. 87 p. 249]

Lubniewski AJ, Nelson JD. Diagnosis and management of dry eye and ocular surface disorders. *Ophthalmol Clin of North Am* 1990;3:575-594. [vol. 87 p. 262]

Mircheff AK, Gierow JP, Wood RL. Traffic of major histocompatibility complex class II molecules in rabbit lacrimal gland acinar cells. *Invest Ophthalmol Vis Sci* 1994;35:3943-3951. [vol. 87 p. 335]

Morgan RV, Abrams KL. Topical administration of cyclosporine for treatment of keratoconjunctivitis sicca in dogs. *J Am Vet Med Assoc* 1991;199:1043-1046. [vol. 87 p. 354]

Olivero DK, Davidson MG, English RV, et al. Clinical evaluation of 1% cyclosporine for topical treatment of keratoconjunctivitis sicca in dogs. *J Am Vet Med Assoc* 1991;199:1039-1042. [vol. 88 p. 042]

PDR (Physicians' Desk Reference). Product information for NEORAL<sup>®</sup> (cyclosporine). Montvale, NJ: Medical Economics Company, Inc; 1998:1882-1889. [vol. 88 p. 103]

Power WJ, Mullaney P, Farrell M, et al. Effect of topical cyclosporin A on conjunctival T cells in patients with secondary Sjögren's syndrome. *Cornea* 1993;12:507-511. [vol. 88 p. 224]

Sanders MD, Graham EM. Ocular disorders associated with systemic diseases. In: Vaughan D, Asbury T, eds. *General Ophthalmology*. 11th ed. Los Altos, CA: Lange Medical Publications; 1986:262-301. [vol. 88 p. 261]

Schein OD, Munoz B, Tielsch JM, et al. Prevalence of dry eye among the elderly. *Am J Ophthalmol* 1997;124:723-728. [vol. 88 p. 311]

Stern ME, Beuerman RW, Fox RI, et al. The pathology of dry eye: the interaction between the ocular surface and lacrimal glands. *Cornea* 1998;17:584-589. [vol. 89 p. 005]

Sullivan DA, Ariga H, Vendramini AC, et al. Androgen induced suppression of autoimmune disease in lacrimal glands of mouse models of Sjögren's syndrome. In: Sullivan, ed. *Lacrimal Gland, Tear Film, and Dry Eye Syndromes*. New York, NY: Plenum Press;1994:683-690. [vol. 89 p. 011]

Williamson J, Gibson AAM, Wilson T, et al. Histology of the lacrimal gland in  
keratoconjunctivitis sicca. Br J Ophthalmol 1973;57:852-858. [vol. 89 p. 075]



### **3.2 FOREIGN MARKETING HISTORY**

#### **3.2.1 COUNTRIES WHERE THE DRUG HAS BEEN MARKETED**

To date, cyclosporine ophthalmic emulsion has not been marketed in any country.

#### **3.2.2 COUNTRIES WHERE THE DRUG HAS BEEN WITHDRAWN FROM MARKETING**

To date, cyclosporine ophthalmic emulsion has not been withdrawn from marketing in any country.

#### **3.2.3 COUNTRIES WHERE MARKETING APPLICATIONS ARE PENDING**

To date, there are no marketing applications pending for cyclosporine ophthalmic emulsion.





### 3.3 CHEMISTRY, MANUFACTURING AND CONTROLS SUMMARY

The product proposed in this New Drug Application (NDA) is cyclosporine ophthalmic emulsion. The proposed clinical indication is for the treatment of moderate to severe keratoconjunctivitis sicca (KCS) with or without Sjögren's Syndrome.

The drug product is a sterile, droppable emulsion, packaged in low density polyethylene (LDPE) unit dose vials (0.4 mL fill volume in 0.9 mL fill capacity). It is an oil-in-water emulsion containing either 0.05% or 0.1% w/w cyclosporine USP. The inactive ingredients are castor oil PhEur, polysorbate 80 NF, carbomer 1342 NF, glycerin USP, sodium hydroxide USP, and purified water USP. The formulation is preservative-free and has a target pH of 7.4. Allergan has assigned formula numbers 9054X and 8735X to the 0.05% and 0.1% cyclosporine ophthalmic emulsions, respectively.

Cyclosporine USP is manufactured by Novartis, formerly known as Sandoz. The stability, method of manufacture and the packaging of cyclosporine are described in Novartis NDAs 50-573 and 50-574.

Cyclosporine ophthalmic emulsion is manufactured at the Allergan Waco facility, Waco Texas. The drug product is manufactured with a commercial batch size of 600 kg from four in-process parts designated Parts 1-4. Part 1 is the oil phase and contains cyclosporine dissolved in castor oil. Part 2 is the aqueous phase and contains purified water, polysorbate 80 and glycerin. Part 3 is the carbomer dispersion and contains purified water and carbomer 1342. Part 4 is the neutralizer phase and is comprised of 1N sodium hydroxide. Each in-process part is manufactured and sterilized separately then combined aseptically under controlled conditions and sequence to form the sterile bulk product.

A sample of the bulk emulsion is taken for pH and physical appearance testing from the transfer line between the main batch vessel and the holding vessel. Allergan will not reprocess the bulk or finished drug product. Any drug product batch failing to meet specifications will be discarded.

The container is a unit dose vial manufactured of Chevron low density polyethylene resin. This resin has been submitted and approved under NDA 20-811 ACULAR PF (ketorolac tromethamine ophthalmic solution) 0.5%. There are no colorants in the resin of the vial and

no additives used in the vial manufacturing process. Both the virgin resin and the formed, molded unit dose vials have been tested to USP <661> CONTAINERS FOR OPHTHALMICS-PLASTICS, and shown to be suitable for ophthalmic pharmaceutical use. A printed pressure sensitive adhesive label is affixed to the tab of each unit dose vial. The secondary package consists of a white thermoformed tray designed to hold thirty-two (32) unit dose vials, sealed with peelable aluminum foil lidding material, and protected with a reclosable overcap. An insert printed with approved text is placed between the overcap and the lidding material. A pressure sensitive label printed with approved text is attached to the top of the overcap.

The requirements with respect to product stability are satisfied by six registration batches of cyclosporine ophthalmic emulsion 0.1% and three registration batches of cyclosporine ophthalmic emulsion 0.05%. Based on the data reported in this application, Allergan proposes a 24-month expiration dating for cyclosporine ophthalmic emulsion 0.1%, and cyclosporine ophthalmic emulsion 0.05%, in the proposed market configuration when the product is stored at USP controlled room temperature. For Professional samples, Allergan proposes an 18-month expiration dating because the product is packaged without a secondary container that minimizes water loss.

### 3.3.1 ACTIVE PHARMACEUTICAL INGREDIENT

Cyclosporine USP is manufactured by Novartis, formerly known as Sandoz. The stability, method of manufacture and the packaging of cyclosporine are described in Novartis NDAs 50-573 and 50-574.

### 3.3.2 DRUG PRODUCT

#### 3.3.2.1 Quantitative Composition

The final composition of the drug product and the batch composition of a production scale (600 kg) batch are shown below for each of the two concentrations.

**Table 3.3.2.1-1 Quantitative Composition of Cyclosporine Ophthalmic Emulsion 0.05% (formula 9054X)**

Ingredient	Concentration (% w/w)	Concentration (mg/g)	Amount for a 600-kg batch (kg)
Cyclosporine USP	0.05	0.5	0.3
Castor Oil PhEur	1.25	12.5	7.5
Glycerin USP	2.2	22	13.2
Polysorbate 80 NF	1.0	10	6.0
Carbomer 1342 NF	0.05	0.5	0.3
1-N Sodium Hydroxide NF	0.397	3.97	2.38
Purified Water USP	95.0	950	570

**Table 3.3.2.1-2 Quantitative Composition of Cyclosporine Ophthalmic Emulsion 0.1% (formula 8735X)**

Ingredient	Concentration (% w/w)	Concentration (mg/g)	Amount for a 600-kg batch (kg)
Cyclosporine USP	0.1	1.0	0.6
Castor Oil PhEur	1.25	12.5	7.5
Glycerin USP	2.2	22	13.2
Polysorbate 80 NF	1.0	10	6.0
Carbomer 1342 NF	0.05	0.5	0.3
1-N Sodium Hydroxide NF	0.397	3.97	2.38
Purified Water USP	95.0	950	570

### 3.3.2.2 Container-Closure System

Cyclosporine ophthalmic emulsion is packaged in a container-closure system consisting of a unit dose vial manufactured from low density polyethylene and filled to a volume of 0.4 mL. The unit dose vial is then labeled for identification. The unit dose vials are packaged into a thermoformed tray manufactured from polypropylene sheeting. The thermoformed tray is heat sealed with aluminum foil peelable lidding. After the polypropylene tray is heat sealed, an insert is placed on the peelable lidding and a reclosable polystyrene overcap is snapped in

place onto the tray. The overcap is then labeled for identification. Refer to Figure 4A.3.5.2-2.

### 3.3.2.2.1 Schematic

**Figure 3.3.2.2-1 Schematic Diagram of Primary Packaging Containers**

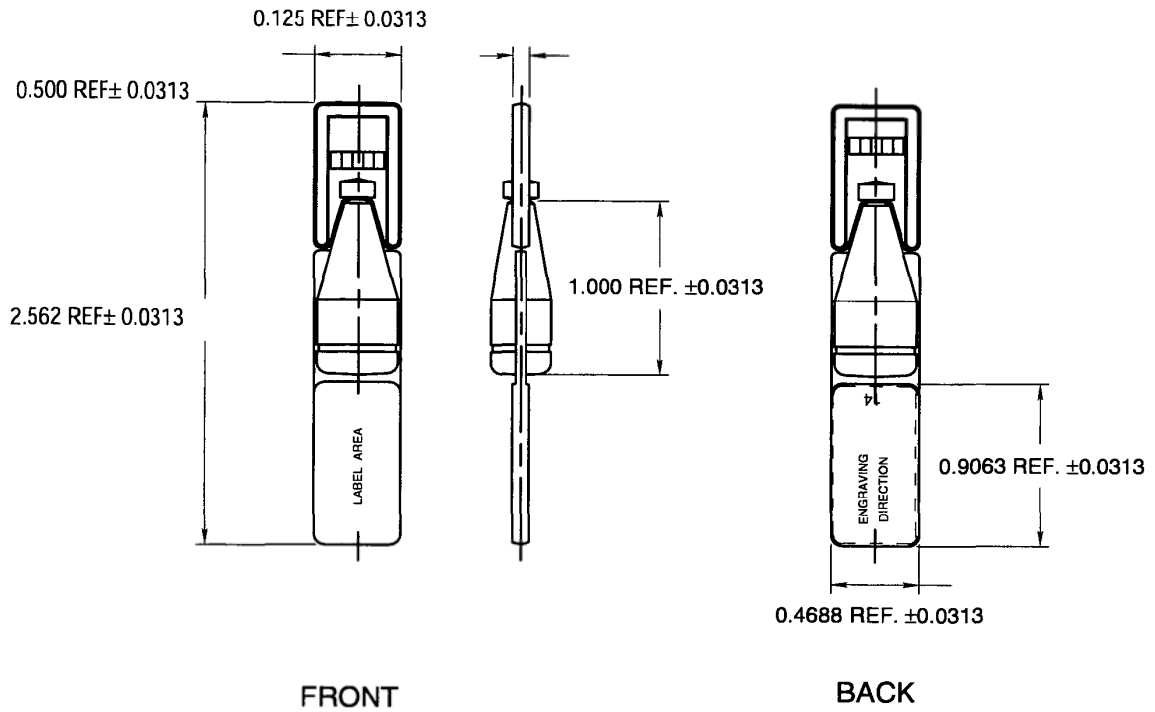
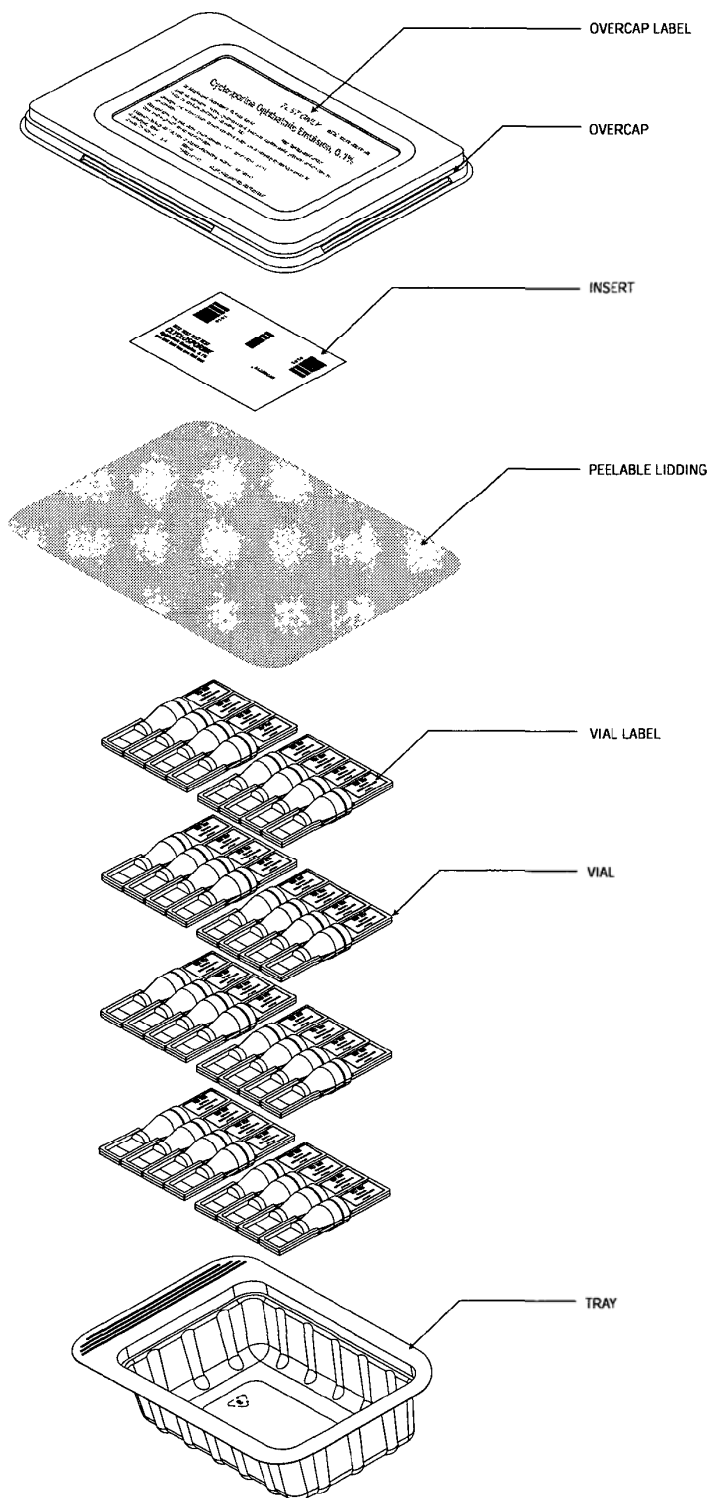

Figure 3.3.2.2-2 Schematic Diagram of Secondary Packaging – Commercial



### 3.3.2.2.1 Qualification of Container and Closures

A summary of the tests performed to meet USP XXII / NF XVII requirements for plastic containers follows. The list contains tests performed on a representative lot of empty vials made from Chevron LDPE 4538A by the same form-fill-seal process used for the product. These tests demonstrate that the manufacturing process produced a container that is suitable for ophthalmic use. All testing meets the requirements for USP XXII / NF XVII and USP 23 / NF 18 for sections <87>, <88>, and <661>.

**Table 3.3.2.2-1 Low Density Polyethylene Resin Qualification Test Results**

Description	Test	Specification	Method
Physicochemical Tests Plastics	Heavy Metals	≤ 1.0 ppm	USP <661>
	Buffering Capacity	≤ 0.100 mEq	USP <661>
	Non-volatile Residue	≤ 15.0 mg	USP <661>
	Residue on Ignition	≤ 5.0 mg	USP <661>
Biological Tests – Plastic and other Polymers	Elution	Meets test requirements	USP <87>
	Systemic Injection	Meets test requirements	USP <88>
	Eye Irritation	Meets test requirements	USP <88>

#### Container Extractables

Container extractables have been investigated by a 2-phase approach. Phase I testing consisted of an extraction procedure based upon the USP <661> procedure for ophthalmic containers whereupon the container was incubated with extraction medium at ≥ 70°C for a minimum period of 48 hours. Control samples of extraction medium were stored in glass in an identical manner to the test articles. Phase I testing incorporated both water and isopropanol as extraction media. Analyses of extracts for container extractables utilized specific gas chromatographic (GC) and high-performance liquid chromatographic (HPLC) assays designed to detect common plastic additives, antioxidants, residual solvents, and other unknown analytes. Both tests utilized on-line mass spectrometric (MS) detection in order to detect, quantitate and identify container-closure extractable compounds where possible.

The results of initial Phase I testing indicated that no toxicologically significant compounds were detected in the resin used to manufacture the unit dose vials. After Phase I extractables testing was performed, additional extractable investigations were performed in stability studies of the cyclosporine ophthalmic emulsion utilizing both the unit dose vial as well as glass ampules (this is defined as Phase II extractables testing). This is performed during registration stability studies.

Phase II extractables testing is described in detail in Stability Section 4A.3.7.1 (Container-Closure Extractable Studies). These studies revealed that two low level extractables were detected. However, the very low calculated daily dose a patient would receive indicates that these extractables are not present at levels of toxicological significance. The conclusion of the Phase I and II extractables studies is that the container-closure system for cyclosporine ophthalmic emulsion is safe and suitable for its intended use.

3.3.2.3 Product Tests, Specifications, and Analytical Methods

**Table 3.3.2.3-1 Product Tests, Specifications, and Analytical Methods for Cyclosporin Ophthalmic Emulsion 0.1 %**

Test	Release Specification	Regulatory Specification	Method
Cyclosporine	95 - 105% of label strength (0.095-0.105 % w/w CSA)	90 - 110% of label strength (0.090-0.110 % w/w CSA)	AP-L280-5
Cyclosporine Identification	Rf value comparable to reference standard	Not Applicable	AP-ID088-1
Microscopic Appearance	Oil globules uniformly dispersed in the aqueous phase	Oil globules uniformly dispersed in the aqueous phase	AP-M003-1
Globule Size: Optical Sensing	NLT 97% of oil volume in globules smaller than 1.2 $\mu\text{m}$	Not Applicable	AP-Z002-5
Turbidity	A 1:5 dilution has a turbidity of NMT 2500 NTU	A 1:5 dilution has a turbidity of NMT 2500 NTU	AP-Z004-1
Viscosity	5 - 150 cps	NMT 150 cps	AP-V008-2
Osmolality	240 - 280 mOsm/kg	230 - 320 mOsm/kg	USP <785>
Physical Appearance	White, opaque to slightly translucent, homogeneous emulsion	White, opaque to slightly translucent, homogeneous emulsion	AP-MS005-2
pH	7.0 - 7.8	6.5 - 8.0	AP-MS005-2
Sterility	Meet test requirements	Meet test requirements	Current USP



**Table 3.3.2.3-2 Product Tests, Specifications, and Analytical Methods for Cyclosporin Ophthalmic Emulsion 0.05%**

Test	Release Specification	Regulatory Specification	Method
Cyclosporine	95 - 105% of label strength (0.0475% - 0.0525 % w/w CSA)	90 - 110% of label strength (0.0450-0.0550 % w/w CSA)	AP-L280-5
Cyclosporine Identification	Rf value comparable to reference standard	Not Applicable	AP-ID088-1
Microscopic Appearance	Oil globules uniformly dispersed in the aqueous phase	Oil globules uniformly dispersed in the aqueous phase	AP-M003-1
Globule Size:			
Optical Sensing	NLT 97% of oil volume in globules smaller than 1.2 µm	Not Applicable	AP-Z002-5
Turbidity	A 1:5 dilution has a turbidity of NMT 2500 NTU	A 1:5 dilution has a turbidity of NMT 2500 NTU	AP-Z004-1
Viscosity	5 - 150 cps	NMT 150 cps	AP-V008-2
Osmolality	240 - 280 mOsm/kg	230 - 320 mOsm/kg	USP <785>
Physical Appearance	White, opaque to slightly translucent, homogeneous emulsion	White, opaque to slightly translucent, homogeneous emulsion	AP-MS005-2
pH	7.0 - 7.8	6.5 – 8.0	AP-MS005-2
Sterility	Meet test requirements	Meet test requirements	Current USP

3.3.2.3.1 Rationale for Drug Product Specifications:

Active Ingredient Concentration

The specifications on the active ensure appropriate dosing levels.

Microscopic Appearance

This specification ensures uniform eyedrop content throughout the product shelf-life.

Globule Size

Particle size distribution is one of the most important physical properties of an emulsion system. It is indicative of the manufacturing consistency. Any change in the particle size

distribution during storage usually correlates with the degree of emulsion stability. The physical stability of the cyclosporine ophthalmic emulsion is monitored in part by measuring the oil globule size distribution using the single particle optical sensing technique and also by measuring turbidity. The results from these two analytical methods are well correlated.

#### Viscosity

The viscosity of a concentrated oil-in-water emulsion in some cases can be substantially higher than that of water as a result of the orderly packing of the oil droplets that form the internal phase. This is not the case with the cyclosporine ophthalmic emulsion because of its low oil content. The moderate viscosity of the drug product is achieved by the presence of Carbomer 1342, which forms a gel-like network around the oil globules and is essential to the emulsion stability. This specification ensures the physical consistency of the drug product as well as the presence of the Carbomer 1342.

#### Osmolality and pH

These specifications ensure manufacturing consistency and that the drug product does not cause unnecessary ocular irritation.

#### Physical Appearance

This specification ensures that there is no apparent phase separation of the cyclosporine ophthalmic emulsion that may impact the content uniformity of the product.

#### Sterility

All ophthalmic products need to be sterile.

#### Water Loss

The effect of water loss on the drug product is monitored by the cyclosporine concentration and osmolality. Therefore water loss is not a separate product specification.

#### 3.3.2.3.2 Rationale for Analytical Tests for Drug Product:

The standard tests generally performed to control the quality of ophthalmic solutions are active ingredient concentration, viscosity, osmolality, physical appearance, pH and sterility. Since this cyclosporine dosage form is an emulsion, additional microscopic appearance, optical sensing, and turbidity analytical methods were developed and validated to

characterize oil globule size. These tests characterize the emulsion stability. The manufacturing process produces very small oil globules; not less than 97% of the oil volume is smaller than 1.2 microns in size. Stability studies have shown the oil globule size to remain stable over time, therefore once the emulsion has been shown to be manufactured properly, the oil globule size does not change significantly over time. For this reason it is necessary to test the emulsion using optical sensing only at the time of finished product release testing. Since the optical sensing data for the cyclosporine ophthalmic emulsion have been shown to correlate with turbidity measurements, only turbidity is monitored during subsequent stability studies.

A summary of each method is presented below:

Cyclosporine (Method AP-L280-5)

Cyclosporin A (CSA) in the ophthalmic emulsion is quantitated by high performance liquid chromatography (HPLC). The sample is analyzed by direct injection of the emulsion onto a Ultrasphere C<sub>8</sub> column and analytes are eluted with a mobile phase consisting of 40/60 (tetrahydrofuran/water, v/v) containing 0.03M phosphoric acid. Detection is by UV absorbance at 210 nm. The method is linear from 40% to 120% of CSA label claim for both the 0.05% and 0.1% CSA formulations with a correlation coefficient (R) of 0.9999 using peak areas. Recovery values for CSA obtained from spiked placebo emulsions at 80%, 100%, and 120% of label claim yielded 99.7%, 99.5%, and 99.1%, respectively, indicating the method is highly accurate. Precision values for different operators on different days were within 2% relative standard deviation (RSD). This method resolves the active drug from the CSA related substances isocyclosporin H, isocyclosporin A, cyclosporin B, cyclosporin D, cyclosporin G, and cyclosporin H. In addition, this method separates CSA from all degradation products generated by intentional thermal and chemical degradation of the ophthalmic emulsion (including placebo degradation products). These data indicate that the method is stability indicating.

Related Substances

No related substance specification is proposed for cyclosporine ophthalmic emulsion because no increase in CSA related substances have been detected during stability studies. This is discussed in detail in the Stability Section.

Cyclosporine Identification (Appendix 4A5.5.3, Method AP-ID-088-1)

The identification of CSA in 0.1% and 0.05% cyclosporine ophthalmic emulsions (8735X and 9054X) is performed by thin layer chromatography (TLC). The method was adapted from the USP method for cyclosporine concentrate for injection. The emulsions and the CSA standard solution are spotted onto a silica gel thin layer chromatography plate. The plate is developed in ethyl ether, dried and then developed a second time in a mixture of ethyl acetate, methyl ethyl ketone, water and formic acid (60:40:2:1). The solvent front is allowed to move 15 cm during the development process. After drying the developed plate, the spots are visualized using Dragendorff's reagent. A positive identification for CSA is the presence of a spot with the same  $R_f$  value as the CSA standard. The method is specific because it separates cyclosporine from any placebo interferences.

Microscopic Appearance (Method AP-M003-1)

The microscopic appearance of the CSA ophthalmic emulsion is determined by optical microscopy. A CSA sample is placed onto a microscope slide and observed under a magnification of 400X. Samples are visually evaluated for conformance to the microscopic appearance specification of oil globules uniformly dispersed in the aqueous phase. In addition, samples are also evaluated for the presence of any agglomerated oil globules. Black and white Polaroid photographs are taken of each sample to document the microscopic appearance.

Globule Size: Single Particle Optical Sensing (Method AP-Z002-5)

Single particle optical sensing (SPOS) has proven to be a valuable technique in the analysis of particle size distributions. Typically, the particles in a sample are individually sized using light obscuration particle sensing and a histogram showing the number of particles of a given size is generated. Because the instrument (an Accusizer) measures the size of each particle individually (using SPOS), it can construct non-uniform particle size distributions. This is advantageous in manufacturing process development since inhomogeneity in the particle size distribution of the sample can be identified. Additionally, since the Accusizer is a gravity feed instrument, it can be used on samples such as oil-in-water emulsions where the size distribution of the emulsion droplets could be altered by more commonly used sampling techniques.

Globule Size: Turbidity (Method AP-Z004-1)

Turbidity is a consequence of intense light scattering, which is sensitive to the size, concentration, and refractive index of particles suspended in the sample. The method is simple, rapid, and reproducible. For cyclosporine ophthalmic emulsions, the turbidity has been shown to increase with decreasing % oil volume of globules < 1.2  $\mu\text{m}$ . The turbidity of a 1 to 5 dilution of cyclosporine ophthalmic emulsion is determined using a Hach Model 2100AN Digital Turbidimeter.

Viscosity (Method AP-V008-2)

The viscosity of cyclosporine ophthalmic emulsion is determined by rotational viscometry using a Brookfield LVTDV-II viscometer at a controlled temperature of  $25.0 \pm 0.5^\circ\text{C}$ .

Osmolality

Osmolality is determined per USP <785> using a calibrated freezing-point depression osmometer.

Physical Appearance and pH (Method AP-MS005-2)

Physical Appearance is determined by visual examination of the unit dose vial as well as cyclosporine ophthalmic emulsion contents. The emulsion is inspected for color and general appearance against a white background. In addition, the emulsion is examined to see whether it has remained uniform and that no separation of the two phases has occurred. Direct pH measurement is performed using a calibrated potentiometric pH meter according to USP <791>.

Sterility (SOP RSD.009)

The sterility of the cyclosporine ophthalmic emulsion within the unit dose vials is confirmed by performing the USP 23 direct transfer method sterility test <71>. The test employs the direct transfer of the entire contents of 20 unit dose vials into 400 mL of sterile culture medium. Two culture media are employed, casein soybean digest broth incubated at 20-25 $^\circ\text{C}$ , and fluid thioglycollate medium to be incubated at 30-35 $^\circ\text{C}$ . After 3 to 7 days of incubation, each primary sterility test culture is aseptically sub-cultured (5 mL volume) into 100 mL of fresh medium. The sub-cultures are then incubated along with the primary cultures for the remaining time of the 14-day primary culture incubation. This sterility test

has been validated by USP bacteriostasis/fungistasis testing on three batches of final product. The validation report for this method is given in Appendix 4A.5.5.9.

#### Stability Testing

Manufacturing standard operating procedure WQC-020 (Appendix 4A.5.5.12, Production QA Stability Program) provides for finished product lots to be placed on stability in accordance with the current Stability Protocol for that product (Appendix 4A.5.3.1). The number of units to be sampled is specified in the Stability Protocol. The Stability Protocol also specifies that units are sampled randomly throughout the lot.

#### 3.3.2.3.3 Stability

Based on the evaluation of up to twelve months of stability data, Allergan proposes a 24-month expiration dating for cyclosporine ophthalmic emulsion 0.1%, and cyclosporine ophthalmic emulsion 0.05%, in the proposed market configuration when the product is stored at USP controlled room temperature. Allergan proposes an 18-month expiration dating when the product is packaged without a secondary container that minimizes water loss. The drug product has a secondary packaging system consisting of a white, thermoformed polypropylene tray. There are 32 unit dose vials in each tray. This secondary packaging system has been shown to prolong the shelf-life of the drug product by reducing water loss.

All registration stability batches have been tested for cyclosporine concentration, cyclosporine related substances, microscopic appearance, oil globule size (by both single particle optical sensing and turbidity), osmolality, pH, viscosity, physical appearance and sterility. The product was also tested using a cyclosporine content uniformity method and a water loss method as measured by the weight loss of the sample. All results of these tests are within the proposed specifications and are reported in the stability report.

#### 3.3.6 CORRELATION OF DRUG SUBSTANCE LOTS USED IN CLINICAL, TOXICOLOGY, AND PRODUCT STABILITY LOTS

The following table correlates the lots of active pharmaceutical ingredient used in the manufacture of cyclosporine ophthalmic emulsion used in all clinical and non-clinical studies.

**Table 3.3.6-1 Active Pharmaceutical Ingredient Lots Used in Clinical and Non-Clinical Studies**

Active Pharmaceutical Ingredient		Drug Product					
Manufacturer Name/ Lot #	Allergan RM#	Lot # (Size)	Formula # (Drug Conc./ Container)*	Clinical Study #	Stability	Toxicology Study #	PK Report #
Sandoz 91200	90896	10622 (10 kg)	8733X (0.4%/ UU)			1793-2936-5 1793-2936-6 CHV985-126	
		10678 (10 gm)	8734X- <sup>3</sup> H (0.2% <sup>3</sup> H/ NA)				PK-95-010 PK-95-011
Sandoz 91009	91010	10621 (12 kg)	8734X (0.2%/ UU)			1793-2936-5 1793-2936-6 CHV985-126	
		10622 (10 kg)	8733X (0.4%/ UU)			1793-2936-5 1793-2936-6 CHV985-126	
		10622 (10 kg)	8733X (0.4%/ UU)			1793-2936-5 1793-2936-6 CHV985-126	
		10650 (14 kg)	8736X (0.05%/ UU)			1793-2936-5 1793-2936-6	
		10718 (13 kg)	8735X (0.1%/ UU)			CHV985-126	

\* UU Unit of Use (1 mL fill in 6 mL Bottle)  
UD Unit Dose (0.4 mL fill volume/ 0.9 mL fill capacity)  
NA no filling in PSO

Table 3.3.6-1 Active Pharmaceutical Ingredient Lots Used in Clinical and Non-Clinical Studies (continued)

Active Pharmaceutical Ingredient		Drug Product						
Manufacturer Name/ Lot #	Allergan RM#	Lot # (Size)	Formula # (Drug Conc./ Container)*	Clinical Study #	Stability	Toxicology Study #	PK Report #	
Sandoz 92359	91198	10717 (12 kg)	8736X (0.05%/ UD)	192371-001				
		10719 (12 kg)	8734X (0.2%/ UD)	192371-001				
		10720 (12 kg)	8733X (0.4%/ UD)	192371-001				
		10768 (12 kg)	8735X (0.1%/ UD)	192371-001				
		10782 (10 gm)	8734X- <sup>3</sup> H (0.2% <sup>3</sup> H/ NA)				PK-95-074	
		10783 (10 gm)	8734X- <sup>3</sup> H (0.2% <sup>3</sup> H/ NA)				PK-95-074	
Sandoz 94410	91219	10795 (10 gm)	8734X- <sup>3</sup> H (0.2% <sup>3</sup> H/ NA)				PK-95-074	
		11142 (100 kg)	8735X (0.1%/ UD)	192371-501				
Sandoz 94417	91241	10813 (12 kg)	8734X (0.2%/ UU)			CHV985-126		
		10814 (12 kg)	8733X (0.4%/ UU)			CHV985-126		

\* UU Unit of Use (1 mL fill in 6 mL Bottle)  
UD Unit Dose (0.4 mL fill volume/ 0.9 mL fill capacity)  
NA no filling in PSO



Table 3.3.6-1 Active Pharmaceutical Ingredient Lots Used in Clinical and Non-Clinical Studies (continued)

Active Pharmaceutical Ingredient		Drug Product							
Manufacturer Name/ Lot #	Allergan RM#	Lot # (Size)	Formula # (Drug Conc./ Container)*	Clinical Study #	Stability	Toxicology Study #	PK Report #		
Sandoz 94427	91272	10876 (10 gm)	8734X- <sup>3</sup> H (0.2% <sup>3</sup> H/NA)				PK-96-016 PK-96-017		
		10898 (10 gm)	8733X- <sup>3</sup> H (0.4% <sup>3</sup> H/NA)				PK-96-011		
		10899 (10 gm)	8736X- <sup>3</sup> H (0.5% <sup>3</sup> H/NA)				PK-96-011		
		10922 (10 gm)	8734X- <sup>3</sup> H (0.2% <sup>3</sup> H/NA)				PK-96-011		
		11101 (100 kg)	8735X (0.1%/UD)	192371-002	X				
Sandoz 94495	91333	11108 (100 kg)	9054X (0.05%/UD)	192371-002 192371-003 192371-501	X				
		11110 (100 kg)	8735X (0.1%/UD)	192371-003 192371-501					
		11259 (100 kg)	8735X (0.1%/UD)		X				

\* UU Unit of Use (1 mL fill in 6 mL Bottle)  
UD Unit Dose (0.4 mL fill volume/ 0.9 mL fill capacity)  
NA no filling in PSO

Table 3.3.6-1 Active Pharmaceutical Ingredient Lots Used in Clinical and Non-Clinical Studies (continued)

Active Pharmaceutical Ingredient		Drug Product						
Manufacturer Name/ Lot #	Allergan RM#	Lot # (Size)	Formula # (Drug Conc./ Container)*	Clinical Study #	Stability	Toxicology Study #	PK Report #	
Sandoz 95017	91360	11109 (100 kg)	8735X (0.1%/ UD)	192371-002 192371-004 192371-501	X			
		11141 (100 kg)	8735X (0.1%/ UD)	192371-002 192371-003				
		11143 (100 kg)	9054X (0.05%/ UD)	192371-002	X			
		11234 (100 kg)	9054X (0.05%/ UD)	192371-003 192371-501				
		11235 (100 kg)	8735X (0.1%/ UD)	192371-006 192371-501				
		11258 (100 kg)	8735X (0.1%/ UD)		X			
		11260 (100 kg)	8735X (0.1%/ UD)	192371-005	X			
Sandoz 95021	91361	11138 (100 kg)	8735X (0.1%/ UD)	NEI-KCS 192371-501	X			
		11139 (100 kg)	9054X (0.05%/ UD)	192371-003 192371-501	X			

\* UU Unit of Use (1 mL fill in 6 mL Bottle)  
UD Unit Dose (0.4 mL fill volume/ 0.9 mL fill capacity)  
NA no filling in PSO

Table 3.3.6-1 Active Pharmaceutical Ingredient Lots Used in Clinical and Non-Clinical Studies (continued)

Active Pharmaceutical Ingredient		Drug Product						
Manufacturer Name/ Lot #	Allergan RM#	Lot # (Size)	Formula # (Drug Conc./ Container)*	Clinical Study #	Stability	Toxicology Study #	PK Report #	
NA	NA	10619 (12 kg)	8746X (vehicle of 0.4%/ UU)			1793-2936-5 1793-2936-6 CH985-126		
		10651 (12 kg)	8747X (vehicle of 0.2/ UU)			1793-2936-6		
		10767 (12 kg)	8747X (vehicle of 0.2%/ UD)	192371-001				
		11102 (100 kg)	8922X (vehicle of 0.1%/ UD)	192371-002				
		11140 (100 kg)	8922X (vehicle of 0.1%/ UD)	192371-501 192371-003 NEJ-KCS				

\* UU Unit of Use (1 mL fill in 6 mL Bottle)  
UD Unit Dose (0.4 mL fill volume/ 0.9 mL fill capacity)  
NA no filling in PSO

**Table 3.3.6-2 Formulations Used in Non-Clinical Studies**

Ingredient, Grade (% w/w)	Formulations X-Number					
	8736X	8735X	8734X	8733X	8747X	8746X
Cyclosporine, USP	0.05	0.10	0.20	0.40	0.00	0.00
Castor Oil, PhEur	0.625	1.25	2.50	5.00	2.50	5.00
Glycerin, USP	2.20	2.20	2.20	2.20	2.20	2.20
Polysorbate 80, NF	1.00	1.00	1.00	1.00	1.00	1.00
Carbomer 1342, NF	0.05	0.05	0.05	0.05	0.05	0.05
Sodium Hydroxide, NF	Adjust pH to 7.4	Adjust pH to 7.4	Adjust pH to 7.4	Adjust pH to 7.4	Adjust pH to 7.4	Adjust pH to 7.4
Purified Water, USP	q.s. ad	q.s. ad	q.s. ad	q.s. ad	q.s. ad	q.s. ad

**3.4 NONCLINICAL  
SUMMARY**

## 3.4 NONCLINICAL DATA SUMMARY

### 3.4.1 PHARMACOLOGY

Topical cyclosporine emulsion appears to be therapeutic through 3 concurrent mechanisms. It is an immunomodulatory agent, an anti-inflammatory agent, and an anti-apoptotic. Through these 3 activities, immune-based inflammation of the ocular surface is suppressed, allowing for the secretion of more normal ocular surface supportive tears and a more stable tear film.

Topical use of cyclosporine exerts a local effect only, an action termed immunomodulatory, rather than any systemic immunosuppressive effect. Topical administration of 0.05% or 0.1% cyclosporine emulsion results in suppression of T-cell activation at an early stage and inhibition of pro-inflammatory cytokine secretion within ocular surface tissues. These concentrations are high enough to be effective without apparent local toxicity, and do not inhibit the body's ability to respond to immune challenges via T-cell proliferation/activation. Challenges to the ocular surface can still be met with T cells as well as B cells, phagocytes and other immune-responsive cells.

Although cyclosporin A is not a classical anti-inflammatory agent and has not been demonstrated to inhibit cyclo-oxygenase, it does inhibit inflammation in other ways. Cyclosporine prevents the synthesis and/or secretion of several TH1 pro-inflammatory cytokines, and is also known to upregulate secretion of TH2-type anti-inflammatory cytokines. Additionally, cyclosporine has been shown to regulate immune-based inflammation within ocular surface tissues by inhibiting intercellular adhesion molecule-1 (ICAM-1).

In the dry-eye dog model after treatment with 0.2% cyclosporine emulsion, lacrimal-accessory-gland acinar apoptosis was undetectable and the number of lymphocytes was vastly reduced in both tissues. The data suggest this restores a more normal functionality to the lacrimal gland. Cyclosporine has been shown to act as a direct inhibitor of apoptosis of acinar epithelium cells.

### 3.4.2 TOXICOLOGY

Preclinical safety studies of cyclosporine ophthalmic emulsion in albino rabbits and beagle dogs have shown that:

- Topically, 0.05%, 0.1%, 0.2% or 0.4% cyclosporine emulsion administered for 6 months in rabbits and 1 year in dogs produced no local or systemic effects. Systemic drug exposure was minimal even though: (a) the animals were treated with exaggerated dosing regimens of up to 0.4% cyclosporine emulsion administered as one ~40  $\mu$ L drop in one eye up to 6 times daily, compared to the intended human dosage of 0.05% or 0.1% cyclosporine emulsion administered as one ~28.5  $\mu$ L drop in both eyes 2 times daily, and (b) the animals were approximately 7 to 20 times smaller in body weight compared to humans.
- The majority of individual blood drug concentrations were less than 1 ng/mL in animals administered cyclosporine ophthalmic emulsion, compared to mean blood drug concentrations that were below the limit of quantitation of 0.1 ng/mL in humans after topical administration of 0.05% or 0.1% cyclosporine emulsion for up to 1 year. The blood cyclosporine concentrations from topical dosing in animals and humans are many hundred fold below those concentrations of 74.9 to 728 ng/mL observed in rheumatoid arthritis and psoriatic patients treated with oral NEORAL<sup>®</sup> (PDR - NEORAL<sup>®</sup>, 1998).
- There were no changes in the kidney, which is the target organ of systemic toxicity with cyclosporine at high doses, nor were there any liver changes.
- No changes were observed in any organ or tissue including the organs related to the immune system (spleen, thymus, lymph nodes).
- No changes in the peripheral blood (white blood cells and lymphocytes) were noted which suggests no impact on the systemic immune system.
- No neurotoxicity was observed.

- All ocular tissues were normal and no ocular infections were observed, indicating intact local immunity in the chronically treated animals.

### 3.4.3 PHARMACOKINETICS

Nonclinical pharmacokinetic studies of cyclosporine ophthalmic emulsions have demonstrated 2 key points:

- Cyclosporine ophthalmic emulsions in rabbits and dogs produce and maintain high, dose-dependent concentrations in cornea and conjunctiva, the ocular surface tissues associated with cyclosporine treatment of dry eye. Calculable elimination half-lives in these tissues after multiple ophthalmic administration ranged from 25.1 to 52.0 hours. Ocular surface tissue concentrations in beagle dogs were comparable to those in albino rabbits.
- Blood concentrations of cyclosporin A in rabbits, dogs, and humans were very low during ophthalmic treatment with cyclosporine emulsions, even during the exaggerated dosing regimens used in toxicological studies. Blood  $C_{max}$  in rabbits and dogs were at least 14 and 7 times higher, respectively, than the blood  $C_{max}$  in humans during ophthalmic treatment with cyclosporine emulsions. However, concentrations in these animals were still more than 440 times lower than the mean blood  $C_{max}$  produced by approved oral treatment with cyclosporine for systemic indications.

Considered in their entirety, the pharmacokinetic data included in this application indicate consistently that cyclosporine concentrations during ophthalmic treatment with 0.05% and 0.1% cyclosporine emulsions are high in ocular target tissues and extremely low in blood. This pharmacokinetic behavior is consistent with ocular efficacy and indicative of systemic safety.





### 3.5 CLINICAL PHARMACOKINETICS SUMMARY

#### 3.5.1 SYSTEMIC EXPOSURE AFTER OPHTHALMIC ADMINISTRATION

Blood concentrations of cyclosporin A following ophthalmic administration of cyclosporine ophthalmic emulsions were measured in human blood using a sensitive liquid chromatography/mass spectrometry-mass spectrometry assay specific for cyclosporin A. The lower limit of quantitation was 0.1 ng/mL.

Blood cyclosporin A concentrations in samples collected during Phase 2 and Phase 3 studies of cyclosporine ophthalmic emulsions were barely detectable:

- In a clinical Phase 2 study of 0.05% to 0.4% cyclosporine emulsions, mean blood cyclosporin A concentrations were below the quantitation limit of 0.1 ng/mL in all 0.05% and 0.1% cyclosporine emulsion-treated patients at all sampling times. The highest blood concentration measured in any patient taking 0.05 or 0.1% cyclosporine emulsion BID in both eyes was 0.102 ng/mL. The highest blood concentration measured in any individual patient in any treatment group was 0.158 ng/mL, and was from a patient treated BID in both eyes with 0.4% cyclosporine emulsion.
- In a clinical Phase 3 study of 0.05% and 0.1% cyclosporine emulsions, mean blood cyclosporin A concentrations were below the quantitation limit of 0.1 ng/mL in both treatment groups at all sampling times. Out of 140 trough blood samples collected from cyclosporine emulsion-treated patients at months 1 or 6, and 208 serial blood samples collected from 26 cyclosporine emulsion-treated patients over one dosing interval at months 9 through 12, only 9 samples contained quantifiable cyclosporin A. All 9 of these samples were from 0.1% cyclosporine emulsion-treated patients, and the highest of them contained 0.299 ng/mL. The other 339 samples, which included all samples from patients treated with 0.05% cyclosporine emulsion, were below the quantitation limit of 0.1 ng/mL.
- The NEORAL<sup>®</sup> labeling indicates that systemic treatment of rheumatoid arthritis and psoriasis with NEORAL<sup>®</sup> produced blood concentrations (mean  $\pm$  SD) that ranged from a trough of  $74.9 \pm 46.7$  ng/mL to a  $C_{\max}$  of  $655 \pm 186$  ng/mL to  $728 \pm 263$  ng/mL (PDR-NEORAL<sup>®</sup>, 1998).

Based on blood concentrations reported during NEORAL<sup>®</sup> treatment compared to those measured during ophthalmic treatment with cyclosporine emulsions, the margins shown in Table 3.5.1-1 indicate that blood concentrations produced by ophthalmic treatment with cyclosporine emulsions are at least several orders of magnitude below those produced by systemic cyclosporine treatments already approved for non-life-threatening conditions.

**Table 3.5.1-1. Comparison of dose and subsequent mean blood C<sub>max</sub>, C<sub>average</sub>, C<sub>min</sub>, and AUC<sub>0-12</sub> between systemic therapeutic use of NEORAL<sup>®</sup> and topical use of 0.05% and 0.1% cyclosporine emulsions.**

Mean parameter	NEORAL <sup>®a</sup>	Cyclosporine ophthalmic emulsions <sup>b</sup>	NEORAL <sup>®</sup> /ophthalmic emulsion ratio
Starting dose (mg/60 kg/day)	150	0.114 (0.1%) 0.0570 (0.05%)	1,320 (0.1%) 2,630 (0.05%)
C <sub>max</sub> (ng/mL) <sup>c</sup>	655	<0.1	>6,550
C <sub>average</sub> (ng/mL) <sup>d</sup>	194	<0.1	>1,940
C <sub>min</sub> (ng/mL) <sup>e</sup>	74.9	<0.1	>749
AUC <sub>0-12</sub> (ng hr/mL) <sup>c</sup>	2,324	<1.2	>1,940

<sup>a</sup> blood cyclosporine concentrations measured during oral treatment of rheumatoid arthritis or psoriasis with NEORAL<sup>®</sup>

<sup>b</sup> blood cyclosporin A concentrations measured during ophthalmic treatment with cyclosporine emulsions

<sup>c</sup> from PDR-NEORAL<sup>®</sup>, 1998 (for NEORAL<sup>®</sup>) and study report PK-98-112 (for cyclosporine emulsions)

<sup>d</sup> calculated as AUC<sub>0-12</sub> (ng•hr/ml)+12 hr

<sup>e</sup> from PDR-NEORAL<sup>®</sup>, 1998 (for NEORAL<sup>®</sup>) and PK-98-109 (for cyclosporine emulsions)

### 3.5.2 OCULAR PHARMACOKINETICS AFTER OPHTHALMIC ADMINISTRATION

The ocular pharmacokinetics of cyclosporine after topical administration have not been investigated in humans. The concentration-time profile of cyclosporin A in tears over the course of one 12 hour dosing interval is being assessed as part of a Phase 3 clinical protocol and will be reported later.



**3.6 MICROBIOLOGY SUMMARY**

Anti-infective drugs only; not applicable.

**3.7 CLINICAL  
SUMMARY**

### 3.7 CLINICAL SUMMARY

#### 3.7.1 CLINICAL PHARMACOLOGY AND PHARMACOKINETICS

##### 3.7.1.1 Background

The immune-based inflammation of both the ocular surface and the lacrimal glands, and the subsequent effects on the entire ocular system suggest a new perspective on the etiologies and pathophysiology of KCS. New therapeutic agents for the treatment of ocular surface disorders can thus target the specific pathology of this syndrome. Autoimmunity, by definition, is an inappropriate activation of T-cells in response to a class II (self) antigen. Some forms of dry-eye disease are secondary to systemic autoimmune diseases, eg, rheumatoid arthritis and systemic lupus erythematosus (SLE). Recent data however show that systemic autoimmunity is not required for a local autoimmune event to occur within the ocular tissue. Current therapy for autoimmune diseases is based on systemic immunosuppression of the patient. Topical cyclosporine ophthalmic emulsion however exerts only a local effect, an action termed immunomodulatory.

##### 3.7.1.2 Assessment of Immune Activation and Inflammatory Response

With local stresses or injuries to the ocular surface, normal tear secretion is altered. Pro-inflammatory tears are secreted, and cytokines are synthesized and secreted by the epithelial cells of the conjunctiva and cornea (Jones et al, 1994). In susceptible patients, such inflammatory changes are the basis of dry eye in the absence of frank autoimmunity. The inflammatory response within the ocular surface tissues is the source of the patient's disease symptoms. Classical clinical evaluations, such as the Schirmer tear test and fluorescein staining, do not correlate well with the patient's perception of disease severity and discomfort. It is the inflammation of the ocular surface that may correlate more specifically with the clinical symptoms and reflect disease severity. Therefore research endpoints (tertiary tests) were added to evaluate markers of immune activation and inflammation.

Biological tissues were collected from subsets of patients in the Phase 3 studies. Conjunctival biopsy specimens were examined using histochemical antibody staining. Specific markers included the infiltrating lymphocytic cells CD3 (total T cells), CD4 (T-helper cells), and CD8

(T-suppressor cells); an immune-reactivity marker HLA-DR; and an inflammation marker CD11a (receptor for intracellular adhesion molecule [ICAM]). The biopsies were also evaluated histologically for the density of goblet cells which are the ocular surface source of mucin, a key component of the tear film. Superficial conjunctival specimens using impression cytology were collected and used as a source of messenger RNA (mRNA) for interleukin-6 (IL-6), an important cytokine associated with inflammation.

### 3.7.1.3 Ocular Surface Inflammation

Increased levels of inflammatory cytokines such as interleukin-1 $\beta$  (IL-1 $\beta$ ), IL-6, and interleukin-8 (IL-8) have been found in patients with Sjögren's syndrome (Pflugfelder et al, 1996; Raphael et al, 1988). These patients also show expression of the immune activation marker HLA-DR and ICAM-1 in the conjunctival epithelium (Jones et al, 1994). Epithelial cells in the lacrimal and salivary tissues have the potential to be antigen-presenting cells. *In vivo*, acinar cells in both the salivary and lacrimal glands of patients strongly express class II antigens (Fox et al, 1986; Jabs and Prendergast, 1988; Jones et al, 1994).

A recent study showed that infiltrating T cells in both lacrimal and salivary glands recognize the shared epitopes (eg, the biochemical structures or parts on the antigen that bind or interact with the T cell) on autoantigens. This suggests the importance of autoantigens with similar epitopes in the initiation of Sjögren's syndrome (Matsumoto et al, 1996). Epithelial cells in inflamed lacrimal or salivary tissues may be able to present autoantigens to the cell surface receptors. This mode of T-cell activation can occur locally in the absence of systemic autoimmunity.

There appear to be 2 distinct mechanisms which can trigger dry-eye disease. First, a localized autoimmune event occurs in the ocular tissues against a purported backdrop of genetic/hormonal predisposition. The loss of normal hormonal support to the lacrimal tissues results in a local environment that facilitates or permits initiation of inflammatory processes. Neurogenic stimulation is thought to play a role in upregulating inflammation in this first mechanism. Second, chronic physical irritation to the ocular surface occurs, such as with contact lens wear, wind, low humidity, or increased abrasive forces from blinking over an ocular surface with an inadequate tear film. Inflammation from chronic physical irritation develops without



predisposing immunoreactivity. Either etiology results in a common immune-based inflammation of the lacrimal glands and ocular surface.

Ocular irritation, inflammation, and the resultant abnormal tear film all interact to create the signs and symptoms of dry-eye disease. Palliative treatments such as artificial tears reduce the increased shear forces which arise from blinking over a non-lubricated ocular surface. They often will provide symptomatic relief to patients, and temporarily may improve fluorescein staining of the ocular surface. Palliative treatments may also decrease the acute irritative-based reactivity and inflammation by reducing the physical irritation which can directly trigger epithelial release of pro-inflammatory cytokines. However chronic palliative treatment alone is inadequate to address, long term, the inflammation of the disease. This is demonstrated by the persistent complaints of patients with dry eye using currently available therapies.

#### 3.7.1.4 Pharmacologic Activity

Within the ocular surface, cyclosporine ophthalmic emulsion acts as an immunomodulator, an anti-inflammatory agent, and a direct inhibitor of pathological epithelial apoptosis.

##### Immunomodulation

The immunomodulatory activity of cyclosporine ophthalmic emulsion is achieved by its selective inhibition of inflammatory cytokines. Interleukin-2 (IL-2) is known to promote and enhance the immune response. Inhibition of the secretion of such cytokines therefore prevents the amplification of immune reactivity, and indirectly the resultant inflammation.

Cyclosporine binds to cyclophilin, which in turn binds to the calcineurin complex and prevents the dephosphorylation of nuclear factor NF-ATc. The nuclear translocation and thus the promoter binding is prevented, and the T cell is unable to be activated. Cyclosporine does not deactivate previously activated T cells, but prevents new T-cell activation. It has also been demonstrated that cyclosporine inhibits activation of nuclear factor NF-κB, which is involved in the regulation of immune and pro-inflammatory cytokine response genes (Meyer et al, 1997; Boss et al, 1998).

#### Anti-Inflammatory Activity

Cyclosporine has been shown to regulate inflammation within the tissues of the ocular surface by inhibiting ICAM-1 expression on endothelial cells (Oran et al, 1997). Expression of this protein is critical to allow migration of lymphocytes and other inflammatory cells through the vessel wall and into the substantia propria and conjunctival epithelium.

In addition to the indirect effect on inflammation, a direct anti-inflammatory action of cyclosporine ophthalmic emulsion is likely mediated by its inhibition of phosphatases. Phosphatases are a ubiquitous class of enzymes involved in a wide range of metabolic processes such as cell proliferation. Cyclosporin A inhibits the serine/threonine phosphatase, calcineurin (Florio et al, 1996). Thus the proliferation of inflammatory cells and subsequent inflammation within the ocular surface and lacrimal glands are prohibited. Cyclosporine's modulation of phosphatase activity is important in maintaining growth factors and other supportive proteins within the ocular surface.

Chronic inflammation in the form of progressive lymphocytic infiltrations in the lacrimal gland and ocular surface is frequently found in dry-eye patients, with or without systemic autoimmune disease. Immunohistochemical studies demonstrated that these infiltrating lymphocytes primarily consist of CD4 (T-helper) cells (Pflugfelder et al, 1986; Pepose et al, 1990). T-helper cells play an important role in the immune response, and also in the inflammatory response through cytokine synthesis. Cyclosporine is known to specifically affect T-helper cells by inhibiting their activation and ability to recruit additional T cells to an immune-active site.

#### Modulation of Pathological Apoptosis

Pathological changes seen in autoimmunity can be related to pathological alterations in the apoptotic state of the tissues. The stability of secretory acinar epithelial cells in normal lacrimal glands is ensured by factors such as Bcl-2 anti-apoptotic cell survival factor, RB-protein (dephosphorylated, maintains terminal differentiation), and circulating androgens (inhibition of inflammation). As inflammatory induction of acinar cell death progresses, the secretory capacity of the glands is compromised. The effects of "downstream" secretion of inflammatory tears to the ocular surface are amplified.

In biopsy tissues from spontaneous, chronic idiopathic dry-eye dogs, pathological changes in apoptosis of lacrimal acinar and conjunctival epithelial cells were observed (Gao et al, 1998). In conjunctival biopsies from KCS patients, alteration of apoptosis was found in the infiltrating lymphocytes (Smith et al, 1999). Flow cytometry is currently being used to evaluate the effect of cyclosporine emulsion on the apoptotic status of epithelial cells from patients enrolled in a large European multicenter trial (Study 192371-501, NDA Section 8.8). Pretreatment data at baseline demonstrate alterations of epithelial apoptosis in patients with dry-eye disease (NDA Section 8.11.5).

#### 3.7.1.5 Conclusions

Cyclosporine ophthalmic emulsion acts concurrently as an immunomodulating agent, an anti-inflammatory agent, and an agent that normalizes the apoptotic status of the ocular surface and lacrimal glands. Evaluation of inflammatory cells subtypes, cytokine expression, and apoptotic markers will help to further describe the pathophysiology of dry-eye disease, and provide a new basis for potential therapeutic agents. Such tests are currently considered basic research measures, but represent important new endpoints for inclusion in future studies of dry-eye disease.

#### 3.7.1.6 References

Boss V, Wang X, Koppelman LF, et al. Histamine induces nuclear factor of activated T cell-mediated transcription and cyclosporin A-sensitive interleukin-8 mRNA expression in human umbilical vein endothelial cells. *Mol Pharmacol* 1998;54:264-272. [vol. 86 p. 200]

Florio T, Perrino BA, Stork PJS. Cyclic 3,5 adenosine monophosphate and cyclosporin A inhibit cellular proliferation and serine/threonine protein phosphatase activity in pituitary cells. *Endocrinology* 1996;137:4409-4418. [vol. 86 p. 278]

Fox RI, Bumol T, Fantozzi R, et al. Expression of histocompatibility antigen HLA-DR by salivary gland epithelial cells in Sjögren's syndrome. *Arthritis Rheum* 1986;29:1105-1111. [vol. 86 p. 289]

Gao J, Schwalb TA, Addeo JV, et al. The role of apoptosis in the pathogenesis of canine keratoconjunctivitis sicca: the effect of topical cyclosporin A therapy. *Cornea* 1998;17:654-663. [vol. 86 p. 303]

Jabs DA and Prendergast RA. Murine models of Sjögren's syndrome. Immunohistological analysis of different strains. *Invest Ophthalmol Vis Sci* 1988;29:1437-1443. [vol. 87 p. 099]

Jones DT, Monroy D, Ji Z, et al. Sjogren's syndrome: cytokine and Epstein-Barr viral gene within the conjunctival epithelium. *Invest Ophthalmol Vis Sci* 1994;35:3493-504. [vol. 87 p. 115]

Matsumoto I, Tsubota K, Satake Y, et al. Common T cell receptor clonotype in lacrimal glands and labial salivary glands from patients with Sjögren's syndrome. *J Clin Invest* 1996;97:1969-1977. [vol. 87 p. 311]

Meyer S, Kohler G, Joly A. Cyclosporine A is an uncompetitive inhibitor of proteasome activity and prevents NF- $\kappa$ B activation. *FEBS Letters* 1997;41:354-358. [vol. 87 p. 330]

Oran A, Marshall JS, Kondo S, et al. Cyclosporin inhibits intercellular adhesion molecule-1 expression and reduces mast cell numbers in the asebia mouse model of chronic skin inflammation. *Br J Dermatol* 1997;136:519-526. [vol. 88 p. 046]

Pepose JS, Akata RF, Pflugfelder SC, et al.. Mononuclear cell phenotypes and immunoglobulin gene rearrangements in lacrimal gland biopsies from patients with Sjögren's syndrome. *Ophthalmology* 1990;97:1599-1605. [vol. 88 p. 146]

Pflugfelder SC, Wilhemus KR, Osato MS, et al. The autoimmune nature of aqueous tear deficiency. *Ophthalmology* 1986;93:1513-1517. [vol. 88 p. 162]

Pflugfelder SC, Ji Z, Naqui R. Immune cytokine RNA expression in normal and Sjögren's syndrome conjunctiva [abstract]. *Invest Ophthalmol Vis Sci* 1996;37:S358. [vol. 88 p. 174]

Raphael M, Bellefgh S, Piette JCH. Conjunctival biopsy in Sjögren's syndrome: correlations between histological and immunohistochemical features. *Histopathology* 1988;13:191-202. [vol. 88 p. 233]

Smith J., Stern M, Gao J, et al. Evaluation of the Conjunctival cell cycle environment in keratoconjunctivitis sicca (KCS). ARVO abstract (submitted 1999). [vol. 88 p. 340]

### 3.7.2 OVERVIEW OF CLINICAL STUDIES

#### 3.7.2.1 Introduction

The Sponsor has conducted 3 double-masked, randomized, vehicle-controlled clinical trials that demonstrate the safety and efficacy of cyclosporine ophthalmic emulsion for the treatment of moderate to severe keratoconjunctivitis sicca (KCS) with or without Sjögren's syndrome. The initial study was a Phase 2 trial that assessed the efficacy, tolerability, and safety of 4 concentrations of cyclosporine ophthalmic emulsion (0.05%, 0.1%, 0.2%, and 0.4%). Based on the results of that study, the 2 subsequent Phase 3 studies evaluated the safety and efficacy of cyclosporine 0.05% and 0.1% ophthalmic emulsions. The Phase 3 trials had an identical study design except that only one trial included pharmacokinetic parameters.

#### 3.7.2.2 Design of the Phase 3 Clinical Trials

Systemically administered SANDIMMUNE<sup>®</sup> was approved for use in organ transplants in 1983, and since that time extensive data have accumulated on the clinical pharmacology and potential uses of cyclosporine for a variety of systemic and ocular conditions. When the Sponsor began designing clinical studies for a new topical preparation, it had a solid base of clinical pharmacology data from the systemic drug literature. Additionally, extensive use of topical ophthalmic cyclosporine for a broad variety of human ocular conditions, as well as the development of topical ophthalmic cyclosporine for the treatment of chronic, idiopathic KCS in the dry-eye dog, were used as starting points for study design.

#### Dosage

Based on pharmacokinetic and other nonclinical studies, clinical studies by Sandoz Pharmaceuticals Corporation (now Novartis Pharmaceuticals Corporation) with SANDIMMUNE<sup>®</sup> ophthalmic ointment 0.5% to 2.0%, and other published studies in humans, the cyclosporine concentrations selected for the Phase 2 study were 0.05%, 0.1%, 0.2%, and 0.4%. Analysis of that study found that response seemed to plateau at the 3 higher concentrations (0.1%, 0.2%, and 0.4%; study report 192371-001, 1997). Therefore, 0.05% and 0.1% were selected for study in the Phase 3 clinical trials.

Following previous clinical studies with SANDIMMUNE<sup>®</sup>, twice-daily treatment was chosen as the dosage regimen. Ocular pharmacokinetic studies in rabbits after a single drop of 0.2% cyclosporine indicate a 26 to 44-hour half-life in most ocular tissues (study report PK-95-010,

1995), suggesting the possibility of once-daily dosing. However, the twice-daily regimen minimizes differences between peak and trough drug levels and was chosen to provide a more constant drug exposure to ocular tissues over the entire dosing interval.

#### Patient Selection Criteria

A set of required subjective symptoms and predefined objective KCS findings were used to select a population of patients with moderate to severe KCS with or without Sjögren's syndrome. Exclusion criteria included end-stage lacrimal disease; patients using medications, devices, or undergoing procedures known to effect a dry-eye condition; and patients whose dry eye was secondary to a primary disease condition other than secondary Sjögren's syndrome. These exclusions were made not because of safety concerns, but because it was thought that such conditions might confound interpretation of study results.

#### Duration of Studies

Building on the results of the Phase 2 study that included 12 weeks of treatment with study medication (study report 192371-001, 1997), treatment duration was extended in the Phase 3 studies to evaluate efficacy at the end of a 6-month treatment period. A variety of tertiary tests were included in the Phase 3 studies to directly evaluate measures of the underlying pathophysiology of dry-eye disease, the target of topical cyclosporine emulsion therapy. A 6-month treatment period allowed sufficient time to observe these immune and inflammatory endpoints. To support the long-term safety of this formulation, the studies will continue for an additional 6 months, for a total of 12 months of study treatment.

#### Timing of Visits

In previous studies with topical ophthalmic cyclosporine, it was noted that the effect of cyclosporine was first apparent after approximately 1 month of treatment. Therefore, in designing the clinical studies, it was decided to schedule the first return visit for efficacy assessment 1 month after initiating treatment. Subsequent visits were at 3, 4, 6, and 12 months.

#### Number of Patients

The number of patients enrolled in each of the Phase 3 studies was based on statistical power calculations for 2 efficacy variables, ocular staining and the Ocular Surface Disease Index<sup>®</sup> (OSDI<sup>®</sup>) scores. For each study, 100 evaluable patients in each treatment group would give adequate power to detect a significant treatment effect. Overall, the Phase 2 and Phase 3 studies

provided a safety database of 1039 patients with KCS, including 714 patients who were exposed to any concentration of cyclosporine ophthalmic emulsion.

#### Choice of Control

The studies were vehicle-controlled, using the same castor-oil-based topical emulsion vehicle as the active study drug. The vehicle was formulated to enhance palliative benefits and to optimize drug delivery of cyclosporine. Thus, it was expected that the vehicle would have a significant beneficial effect.

#### Efficacy Endpoints in the Phase 3 Studies

Assessments of objective signs and subjective symptoms have been considered the mainstay of dry-eye disease diagnosis and evaluation (Lemp, 1995; Lemp and Chacko, 1997). Objective signs used by the Sponsor in Phase 3 studies included ocular surface staining, Schirmer tear test, and tear break-up time. Subjective symptoms included blurred vision, ocular dryness, burning and stinging, sandy or gritty feeling, and photophobia. The desire to evaluate the subjective components of the disease in an expanded way prompted the use of the OSDI<sup>®</sup>, the Facial Expression Subjective Rating Scale, and the use of REFRESH<sup>®</sup> artificial tears. In addition to these standard objective and subjective assessments, several tertiary tests were used to objectively measure the effect of cyclosporine on the immune and inflammatory mechanisms underlying the disease.

*Staining:* To assess damage to the ocular surface, staining techniques are used to evaluate both the cornea and the conjunctiva. In progressive dry-eye disease, the absence of ocular lubrication results in increased abrasive forces affecting the ocular surface, particularly the cornea. Because of the cornea's role in vision, evaluation of corneal pathology due to dry-eye disease is a particularly important assessment. Corneal staining may be performed with fluorescein (Lemp, 1995; Lemp and Chacko, 1997), which stains areas of denuded epithelium and compromised epithelial junctions (punctate staining). Historically (and in the Phase 2 study), conjunctival staining has been performed using rose bengal. However, quantities of rose bengal stain, large enough for clinical trial use, were not available. Lissamine green was used to assess conjunctival pathology in the Phase 3 studies because it functions similarly to rose bengal but causes less patient discomfort (Lemp, 1995; Norn, 1973).



*Schirmer Tear Test:* This test without anesthesia measures both normal aqueous secretion and stimulated aqueous secretion; the test with anesthesia blocks stimulated secretion and measures only the normal flow. The studies included both tests. Wetting of less than 5 mm of the Schirmer strip after 5 minutes (less than 3 mm when anesthesia is used) is considered to suggest an aqueous tear deficiency (Lemp and Chacko, 1997).

*Tear Break-up Time:* This measures the time to appearance of dry spots on the ocular surface following a blink and is a rough estimate of a compromised or abnormal tear film. A break-up time less than 10 seconds is generally considered abnormal and suggests an unstable tear film (Lemp and Chacko, 1997).

*Ocular Surface Disease Index<sup>®</sup> (OSDI<sup>®</sup>):* This validated (OSDI<sup>®</sup> Validation Final Report, 1998) 12-item questionnaire includes questions on ocular symptoms, ocular sensitivity to environmental insult, and the effect of eye problems on the ability to perform routine tasks (vision-related function).

*Facial Expression Subjective Rating Scale:* This instrument consisted of 9 expressive faces, ranging from the happiest to the unhappiest face, categorized into 5 grades. Patients chose the face that reflected how their eyes felt over the past week.

*Symptom Questionnaire:* Patients evaluated the dry-eye symptoms of blurred vision, dryness, sandy or gritty feeling, burning/stinging, pain, itching, and sensitivity to light on a 5-point scale (0 = none to 4 = very severe). In addition, individual symptoms were summed to construct a composite score to generally reflect the basis of discomfort associated with KCS.

*REFRESH<sup>®</sup> Use:* Because of the severity of KCS, patients in all study groups were allowed to instill the artificial tear REFRESH<sup>®</sup> during the study. A decrease in the amount of REFRESH<sup>®</sup> used over the course of the study would indicate that patients were benefiting from their study treatment and were relying less on the use of artificial tears to relieve their dry-eye symptoms.

*Tertiary Tests:* These included histological evaluation of conjunctival biopsies using standard light microscopy as well as immunohistochemical evaluation of monoclonal antibodies for cell surface markers to determine the presence and activation of T cells and other immune-related endpoints; collection of superficial conjunctival epithelium (impression cytology) to evaluate messenger RNA (mRNA) expression for interleukin-6 (IL-6), a cytokine known to be actively involved in the inflammatory processes; collection of conjunctival impressions, as an additional

method to evaluate the density of goblet cells, which are responsible for the production of the mucin layer of the tear film; and tear osmolality, which is increased in the presence of aqueous tear deficiency.

#### Pharmacokinetics

To evaluate the amount of cyclosporine absorbed into blood and present in tears after topical ocular administration, pharmacokinetic variables were evaluated in the Phase 2 study and one of the Phase 3 studies (192371-002). In the former, blood samples were taken after 1, 4, and 12 weeks of treatment; trough and peak ( $C_{max}$ ) cyclosporin A blood concentrations were evaluated. In the latter, blood cyclosporin A trough concentration was evaluated at baseline and after 1 and 6 months, and blood cyclosporin A area under the curve (AUC) was evaluated after 9 to 12 months in a subset of patients. The 12-month tear cyclosporin A AUC data will be submitted to the Investigational New Drug Application (IND) at a later date.

#### Laboratory Testing

Autoantibody tests performed to facilitate an objective diagnosis of Sjögren's syndrome (SS) were antinuclear antibody (ANA), rheumatoid factor (RF), and Sjögren's syndrome antibodies class SS-A (Ro) and class SS-B (La).

#### Safety Testing

In addition to adverse event reporting, several routine ophthalmic safety tests were conducted including visual acuity measurements, measurement of intraocular pressure (IOP), and biomicroscopy. Additionally, in the Phase 2 study (192371-001), blood chemistry and hematology were evaluated for all patients. Conjunctival swabs were also obtained from a subset of patients in this study to evaluate any qualitative changes in ocular microflora. Since no changes from baseline were observed in any blood chemistry and hematology endpoints, and no ocular infections occurred during the Phase 2 trial, the Sponsor and FDA concurred at a post-Phase 2 meeting that these endpoints did not need to be included for further evaluation in the Phase 3 program.

#### 3.7.2.3 FDA/Sponsor Discussions

The design and analysis of the clinical studies were discussed between the Sponsor and the FDA at 2 end of Phase 2 meetings, in other meetings, and in telephone conversations.

Major agreements included:

- There were no safety concerns with any of the drug concentrations being studied.
- The Sponsor should show efficacy in at least 1 objective sign and 1 subjective endpoint.
- The Sponsor should show a clinically relevant improvement from baseline in ocular surface staining of at least one grade (0 to 5 scale).
- Use of the OSDI<sup>®</sup> was acceptable; the OSDI<sup>®</sup> must be validated.
- The Sponsor should conduct Phase 3 trials with both 0.05% and 0.1% cyclosporine concentrations to ensure the lowest effective dose is identified.
- No ocular microbiological data would be required from the Phase 3 trials.
- The NDA could be filed based on results from the first 6 months of masked treatment.
- The Facial Expression Subjective Rating Scale could be used instead of the OSDI<sup>®</sup> as the key subjective efficacy variable.
- The use of ocular surface staining was preferred over Schirmer as the primary objective endpoint and was recommended by the FDA.
- The primary statistical analysis would be intent-to-treat with last observation carried forward.

3.7.2.5 References

Study Report References

STUDY NUMBER	STUDY TITLE	VOLUME	PAGE
192371-001	A dose-ranging study evaluating the safety, tolerability, and efficacy of cyclosporine (0.05, 0.1, 0.2, 0.4%) and vehicle ophthalmic emulsions in the treatment of moderate to severe keratoconjunctivitis sicca. Allergan, 1997.	vol. 27	p. 002
OSDI® Validation Final Report	Validity and reliability of the ocular surface disease index questionnaire in patients with dry eye. Allergan, 1998.	vol. 85	p. 109

Literature References

Lemp MA. Report of the National Eye Institute/Industry Workshop on Clinical Trials in Dry Eyes. CLAO J 1995;21:221-232. [vol. 87 p. 237]

Lemp MA, Chacko B. Diagnosis and treatment of tear deficiencies. In: Tasman W, Jaeger E, eds. Duane's Clinical Ophthalmology. Philadelphia: Harper and Row; 1997; chapter 14:1-13 (updated 1991). [vol. 87 p. 249]

Nom MS. Lissamine green. Vital staining of cornea and conjunctiva. Acta Ophthalmol 1973;51:483-491. [vol. 88 p. 030]

### 3.7.3 CONTROLLED CLINICAL STUDIES

#### 3.7.3.1 Introduction

Three controlled studies are presented in this NDA to support approval of 0.05% cyclosporine ophthalmic emulsion for the treatment of moderate to severe keratoconjunctivitis sicca (KCS). Study 192371-001 (study report, 1997) was a Phase 2, vehicle-controlled dose-response study that assessed the efficacy, tolerability, and safety of 4 concentrations of cyclosporine ophthalmic emulsion (0.05%, 0.1%, 0.2%, and 0.4%). Based on the results of that study, the Phase 3 vehicle-controlled studies 192371-002 and 192371-003 (hereafter referred to as studies 002 and 003, respectively; study reports, 1999) evaluated the safety and efficacy of cyclosporine 0.05% and 0.1% ophthalmic emulsions.

Although KCS can be a severe and debilitating disease, current treatment options are palliative, providing symptomatic relief without addressing the underlying mechanisms of the disease. In contrast, as shown in these studies, cyclosporine ophthalmic emulsion improves the signs and symptoms of KCS and reduces the ocular inflammation and immune reactivity associated with the disease, thus providing therapeutic benefit.

Five controlled clinical trials in KCS patients have been conducted previously (not by the Sponsor) with ophthalmic administration of cyclosporine. Those studies are not included here because they used a corn-oil based ointment formulation and an emulsion in olive oil, different formulations than the oil emulsion formulation that is the subject of this NDA.

In this section, the Phase 2 study is summarized first, reflecting the chronological sequence of studies rather than the priority of their efficacy results for the NDA. Because both Phase 3 studies had the same study design, they are presented together in a side-by-side fashion. The summary of efficacy from the Phase 3 studies primarily focuses on the objective efficacy parameters corneal staining and Schirmer tear test with anesthesia, and the subjective endpoints blurred vision and REFRESH<sup>®</sup> use.

#### 3.7.3.2 Tabular Presentation of Studies

The following tables summarize the study design and demographic information for the 3 controlled clinical studies.

**Table 3.7.3.2-1 Phase 2 Clinical Study 192371-001**  
A Dose-Ranging Study Evaluating the Safety, Tolerability, and Efficacy of Cyclosporine (0.05, 0.1, 0.2, 0.4%) and Vehicle Ophthalmic Emulsions in the Treatment of Moderate to Severe Keratoconjunctivitis Sicca

Study No.	Investigators	Study Design	Treatment Dose	Duration	No. of Patients	Mean Age (Range)	Sex	Race	Full Report	Case Report Forms	Tabulations
192371-001	P Donschik GN Foulks HA Helms RA Laibovitz M Lopatynsky E Nelson P Rapoza OD Stevenson J Tauber	multicenter double-masked randomized parallel-group dose-response	cyclosporine ophthalmic emulsion 0.05% BID  cyclosporine ophthalmic emulsion 0.1% BID  cyclosporine ophthalmic emulsion 0.2% BID  cyclosporine ophthalmic emulsion 0.4% BID  vehicle of cyclosporine ophthalmic emulsion 0.2% BID	2 weeks washout phase  12 weeks treatment phase  4 weeks post treatment phase	162 moderate to severe KCS	58.6 years (31 to 88)	M: 16% F: 84%	C: 90% B: 7% A: <1% H: 3% O: 0%	NDA Section 8.11.1  vol. 27 p. 002	NDA Section 12.1  vol. 152p. 004	NDA Section 11.1

Abbreviations: BID = twice daily; KCS = keratoconjunctivitis sicca; M = male, F = female; C = Caucasian, B = black, A = Asian, H = Hispanic, O = other

**Table 3.7.3.2-2 Phase 3 Clinical Study 192371-002**

A Multicenter, Double-Masked, Randomized, Vehicle-Controlled, Parallel-Group Study of the Safety and Efficacy of Cyclosporine 0.05% and 0.1% Ophthalmic Emulsions Used Twice Daily for Up To One Year in Patients with Moderate to Severe Keratoconjunctivitis Sicca.

Study No.	Investigators	Study Design	Treatment Dose	Duration	No. of Patients	Mean Age (Range)	Sex	Race	Full Report	Case Report Forms	Tabulations
192371-002	G Berdy RJ Epstein RJ Foerster SL Forstot DG Heidemann JD Nelson DG O'Day H Perry K Sall RM Schiffman OD Stevenson WC Steward KG Stonecipher SD Trocome	multicenter double-masked randomized parallel-group vehicle- controlled	cyclosporine ophthalmic emulsion 0.05% BID cyclosporine ophthalmic emulsion 0.1% BID common vehicle of cyclosporine ophthalmic emulsion 0.05% and 0.1% BID	2 weeks run-in phase 6 months vehicle- controlled masked treatment phase 6 months cyclosporine treatment extension phase	405 moderate to severe KCS	59.3 years (21 to 90)	M: 21% F: 79%	C: 77% B: 5% A: 4% H: 14% O: <1%	NDA Section 8.11.2 vol. 40 p. 001	NDA Section 12.2 vol. 152p. 021	NDA Section 11.2 vol. 124p. 002

Abbreviations: BID = twice daily; KCS = keratoconjunctivitis sicca; M = male, F = female; C = Caucasian, B = black, A = Asian, H = Hispanic, O = other

**Table 3.7.3.2-3 Phase 3 Clinical Study 192371-003**

A Multicenter, Double-Masked, Randomized, Vehicle-Controlled, Parallel-Group Study of the Safety and Efficacy of Cyclosporine 0.05% and 0.1% Ophthalmic Emulsions Used Twice Daily for Up To One Year in Patients with Moderate to Severe Keratoconjunctivitis Sicca.

Study No.	Investigators	Study Design	Treatment Dose	Duration	No. of Patients	Mean Age (Range)	Sex	Race	Full Report	Case Report Forms	Tabulations
192371-003	PA Asbell LG Barber M Burke HD Cavanagh PC Donshtik GN Foulks M Friedlander RS Friedman ME Greenberg AB Gruber RA Laibovitz N Mamilis DL McGarey TK Mundorf CS Ostrov SC Pflugfelder MA Sansone DJ Schanzlin JD Sheppard J Stampler J Tauber RD Williams RW Yee	multicenter double-masked randomized parallel-group vehicle- controlled	cyclosporine ophthalmic emulsion 0.05% BID cyclosporine ophthalmic emulsion 0.1% BID common vehicle of cyclosporine ophthalmic emulsion 0.05% and 0.1% BID	2 weeks run- in phase 6 months vehicle- controlled masked treatment phase 6 months cyclosporine treatment extension phase	472 moderate to severe KCS	59.8 years (24 to 90)	M: 16% F: 84%	C: 91% B: 4% A: 1% H: 4% O: <1%	NDA Section 8.11.3 vol. 60 p. 001	NDA Section 12.3 vol. 163p. 002	NDA Section 11.3 vol. 138p. 002

Abbreviations: BID = twice daily; KCS = keratoconjunctivitis sicca; M = male, F = female; C = Caucasian, B = black, A = Asian, H = Hispanic, O = other



### 3.7.3.3 Phase 2 Dose-Response Study

#### Objective

To evaluate the safety, tolerability, and efficacy of 0.05%, 0.1%, 0.2%, and 0.4% cyclosporine ophthalmic emulsions compared with the vehicle of 0.2% cyclosporine in patients with moderate to severe KCS with or without Sjögren's syndrome.

#### Design

The study was double-masked, randomized, multicenter, and parallel-group in design. After a 2-week washout phase (when patients instilled REFRESH<sup>®</sup> artificial tears in each eye between 4 and 8 times daily), patients were randomized to a treatment group and instilled the study drug in each eye twice daily (BID) for 12 weeks. Patients also used REFRESH<sup>®</sup> as needed up to 8 times daily. The treatment phase was followed by a 4-week post-treatment phase. The results for the treatment phase are reported here.

#### Study Population

Key inclusion criteria were Schirmer (without anesthesia)  $\leq 7$  mm/5 minutes in at least 1 eye (if Schirmer was 0 mm, Schirmer with nasal stimulation  $\geq 3$  mm/5 minutes in at least 1 eye), an average superficial punctate keratitis (SPK) score of +1 in either eye, and at least 1 subjective symptom of ocular discomfort with a score of +2 in either eye. Key exclusion criteria were Schirmer  $< 3$  mm/5 minutes in both eyes after nasal stimulation, frank ocular infection or non-KCS ocular inflammation, corneal disorder or abnormality affecting corneal sensitivity or normal spreading of the tear film (except SPK), occlusion of the lacrimal puncta within 3 months prior to study entry, and neurotrophic corneas or history of anterior segment surgery or trauma that could affect corneal sensitivity.

#### Evaluation Criteria

Objective efficacy endpoints were corneal staining (referred to in the study report as superficial punctate keratitis, SPK), the Schirmer tear test without anesthesia, and conjunctival staining using rose bengal. Subjective endpoints were symptoms of dry eye, the Ocular Surface Disease Index<sup>®</sup> (OSDI<sup>®</sup>), investigator's evaluation of global response to treatment, and REFRESH<sup>®</sup> use. Tear film debris, tear break-up time, brush cytology, tear meniscus height, meibomian gland health, and tear proteins also were evaluated. Safety measures were adverse events, formulation tolerability, conjunctival microbiology,

biomicroscopy, intraocular pressure (IOP), vital signs (pulse and blood pressure), visual acuity (by Regan Letter Acuity Chart), blood chemistry and hematology. In addition, whole blood cyclosporin A levels were determined.

#### Statistical Methods

The efficacy analyses used data from all patients/visits that satisfied criteria detailed in the protocol. The safety analysis included data from all patients. Categorical variables (eg, corneal staining, Schirmer tests, and symptoms) were summarized by descriptive statistics.

Comparisons across treatment groups were analyzed by the Kruskal-Wallis test. Comparisons between groups were analyzed by the Wilcoxon rank sum test. Comparisons for continuous variables (eg, REFRESH<sup>®</sup> use, IOP, and laboratory variables) were analyzed by analysis of variance. Adverse event data were summarized by frequency tables. Two-sided tests with P values  $\leq 0.05$  were considered statistically significant for testing of all main effects.

The heterogeneity of the enrolled patients was greater than expected resulting from the protocol-specified entry criteria for signs and symptoms of KCS. The planned analyses were to be done on intent-to-treat (ITT) and preferred populations (the latter defined as evaluable patients with efficacy data from at least 1 follow-up visit at week 4 or later). Because of the heterogeneity, the overall preferred population was retrospectively divided into subpopulations based upon the severity of dry eye for statistical analyses. This subpopulation, referred to as the preferred-Phase 3 target subpopulation, included patients who met the criteria for the preferred population, had at least 1 eye with a Schirmer = 5 mm at baseline (week 0), and had SPK = 1.5 averaged over both eyes. Results for this subpopulation, which included 54% (88/162) of the patients enrolled in the study, are presented here because it represented the population of interest for subsequent studies. Results of all efficacy analyses (ITT, preferred, preferred-Phase 3 target subpopulation, preferred-reflex tear responder subpopulation, and preferred-Sjögren's subpopulation) are included in the clinical study report in NDA Section 8.11.1.

#### Patient Disposition and Demographics

Nine US sites enrolled 162 patients, 129 in cyclosporine groups and 33 in the vehicle group. Most patients (92.6%, 150/169) completed the study; 7.4% (12/169) were discontinued. Of the 12 discontinuations, 4 were due to adverse events and 8 were for other reasons. No patient discontinued due to lack of efficacy.

Patient demographics for the ITT population are summarized in Table 3.7.3.3. There were no statistically significant differences among the treatment groups for any of the demographic variables (NDA Section 8.11.1, Attachment 9, Table 7).

**Table 3.7.3.3 Phase 2 Study: Summary of Demographics (ITT Population)**

Parameter	Vehicle	Cyclosporine				Total
		0.05%	0.1%	0.2%	0.4%	
Age, N	33	31	32	34	32	162
Mean (SD), years	61.2	58.5	56.5	58.0	58.9	58.6
Range	37.7 - 87.7	35.7 - 80.0	39.5 - 75.9	31.4 - 75.1	33.0 - 82.4	31.4 - 87.7
Race, N (%)						
White	28 (84.8)	28 (90.3)	27 (84.4)	33 (97.1)	29 (90.6)	145 (89.5)
Black	3 ( 9.1)	3 ( 9.7)	3 ( 9.4)	1 ( 2.9)	2 ( 6.3)	12 ( 7.4)
Asian	1 ( 3.0)	0 ( 0.0)	0 ( 0.0)	0 ( 0.0)	0 ( 0.0)	1 ( 0.6)
Hispanic	1 ( 3.0)	0 ( 0.0)	2 ( 6.3)	0 ( 0.0)	1 ( 3.1)	4 ( 2.5)
Sex, N (%)						
Male	5 (15.2)	4 (12.9)	3 ( 9.4)	5 (14.7)	9 (28.1)	26 (16.0)
Female	28 (84.8)	27 (87.1)	29 (90.6)	29 (85.3)	23 (71.9)	136 (84.0)
Iris Color, N (%)						
Blue	10 (30.3)	9 (29.0)	9 (28.1)	12 (35.3)	11 (34.4)	51 (31.5)
Brown	13 (39.4)	12 (38.7)	17 (53.1)	12 (35.3)	11 (34.4)	65 (40.1)
Green	6 (18.2)	3 ( 9.7)	0 ( 0.0)	3 ( 8.8)	5 (15.6)	17 (10.5)
Black	0 ( 0.0)	1 ( 3.2)	0 ( 0.0)	0 ( 0.0)	0 ( 0.0)	1 ( 0.6)
Hazel	4 (12.1)	6 (19.4)	6 (18.8)	7 (20.6)	4 (12.5)	27 (16.7)
Other	0 ( 0.0)	0 ( 0.0)	0 ( 0.0)	0 ( 0.0)	1 ( 3.1)	1 ( 0.6)

Note: SD = standard deviation

### Objective Efficacy Measures

**Corneal Staining:** Statistically significant within-group decreases ( $P \leq 0.004$ ) from baseline for corneal staining occurred in the cyclosporine 0.1%, 0.2%, and 0.4% groups at all time points during the 12-week treatment period. Mean improvement from baseline was greatest (approximately 1.3 grades on a 4-grade scale) in the 0.1% cyclosporine group at all treatment visits, although there were no statistically significant differences among the treatment groups.

**Schirmer Tear Test without Anesthesia:** The most consistent increase from baseline in Schirmer values during the treatment period occurred within the cyclosporine 0.1% group. The increase ranged from 4.3 mm/5 min at week 8 to 2.8 mm/5 min at week 12, although within-group changes from baseline were not statistically significant. There were no statistically significant among-group differences during the treatment period.

**Conjunctival Staining with Rose Bengal:** Statistically significant within-group from baseline for nasal interpalpebral conjunctival staining occurred within the 0.05%, 0.1%, and 0.2% cyclosporine groups at all treatment weeks, with the greatest magnitude of improvement in the

0.1% cyclosporine group (approximately 0.9 grade on a 4-grade scale). Statistically significant improvement from baseline also occurred for temporal interpalpebral conjunctival staining at all treatment visits in the 0.1% cyclosporine group (approximately 1.1 grades).

#### Subjective Efficacy Measures

*Symptoms:* Information on symptoms was collected from queries at scheduled visits that were conducted by a health professional and recorded on the case report forms (CRFs) and from self-administered patient diaries. Baseline results suggested that patients may have consistently underreported symptom severity when responding to the CRF queries compared to when they were using diaries. Therefore, results are presented from diaries. Six symptoms (dryness, sandy or gritty feeling, burning/stinging, pain, itching, and sensitivity to light) were each rated on a 5-grade scale (from no discomfort to discomfort that interferes with normal daily activity). Improvement for sandy or gritty feeling was statistically significantly greater ( $P = 0.01$ ) in all 4 cyclosporine treatment groups (approximately 0.3 to 1.0 grade) compared to a worsening in the vehicle group at treatment week 12.

*Facial Expression Rating Scale:* This scale consisted of 9 expressive faces, ranging from the happiest (picture 1) to the unhappiest face (picture 9). Responses were categorized into 5 grades. There were no statistically significant changes from baseline at any treatment visit, and no statistically significant differences among the treatment groups.

*Ocular Surface Disease Index<sup>®</sup>:* The OSDI<sup>®</sup> is a validated 12-item questionnaire designed to provide a rapid assessment of the symptoms of ocular irritation consistent with dry-eye disease and their impact on vision-related functioning. An overall OSDI<sup>®</sup> score between 0 and 1 was calculated as the sum of the responses for all questions answered (each rated from 0 = none of the time to 4 = all of the time) divided by the total possible score. Statistically significant decreases from baseline (improvement) occurred at the end of the 12-week treatment period in the 0.1% and 0.2% cyclosporine groups, with the greatest magnitude of improvement in the 0.1% cyclosporine group at the end of the 12-week treatment period (0.15 grade). Among-group differences favoring 0.1% cyclosporine were statistically significant ( $P = 0.038$ ) at the end of the 12-week treatment period. Improvement from baseline in the 0.1% cyclosporine group was greater than improvement in the 0.05% and 0.2% cyclosporine groups.

*REFRESH<sup>®</sup> Use:* This information could not be collected using an inventory approach because patients did not return all REFRESH<sup>®</sup> supplies. Therefore, use reported by patients was analyzed. The need for concomitant use of REFRESH<sup>®</sup> was greater in the vehicle group than in the 0.05%, 0.2%, and 0.4% cyclosporine groups by treatment week 12, although these differences were not statistically significant. The fewest average unit doses of REFRESH<sup>®</sup> used per day was 3.3 units for the vehicle group and, among the cyclosporine groups, 2.4 units per day in the 0.05% cyclosporine group.

*Investigator's Evaluation of Global Response:* This evaluation used a 7-point scale, from condition worsened to condition improved approximately 100% (completely cleared). Some investigators rated global response based on their objective clinical evaluations of the patients while others queried the patients directly. The percentages of patients at treatment week 12 evaluated as having a moderate response, marked response, almost cleared, or completely cleared were 36%, 18%, 29%, 36%, and 18% with 0.05%, 0.1%, 0.2%, and 0.4% cyclosporine emulsion and vehicle, respectively.

#### Other Measures

Statistically significant improvement in tear film debris occurred in the 0.1% cyclosporine group at treatment weeks 8 and 12. There were no statistically significant differences among the treatment groups at any treatment visit. For tear break-up time, brush cytology, tear meniscus height, meibomian gland health, and tear proteins, statistically significant differences that occurred within and among the treatment groups were few and usually limited to a single time point.

#### Extent of Exposure

The maximum duration of treatment was 12 weeks. In each of the treatment groups, 90% or more of the patients had at least 8 weeks of treatment exposure.

#### Safety

The incidences of patients with one or more any adverse events regardless of causality were 9.7% (3/31), 12.5% (4/32), 17.6% (6/34), 21.9% (7/32), and 30.3% (10/33) with cyclosporine 0.05%, 0.1%, 0.2%, and 0.4%, and vehicle, respectively. The most frequently reported adverse events regardless of causality in all treatment groups were ocular burning and SPK, reported by 5 patients each across all treatment groups.

Two patients experienced serious adverse events (SAEs) during the study. One patient treated with vehicle had depression requiring hospitalization, and one patient treated with 0.4% cyclosporine had an acute anterior myocardial infarction. Neither event was considered treatment-related. Four patients discontinued the study due to adverse events, 1 patient in the cyclosporine 0.2% group (ocular burning and hyperemia), 1 patient in the 0.4% cyclosporine group (myocardial infarction), and 2 patients in the vehicle group (one due to ocular burning and visual disturbance and one due to conjunctivitis and contact dermatitis).

The cyclosporine groups generally had fewer ocular microorganisms than the vehicle group, and no significant changes in the microbial ocular flora were observed following cyclosporine treatment. No ocular infections were reported in any of the cyclosporine treatment groups.

There were no notable differences between vehicle and cyclosporine treatment groups for biomicroscopy, intraocular pressure, pulse, blood pressure, visual acuity, or laboratory data.

Comparison of trough whole blood concentrations of cyclosporin A suggested no substantial accumulation following multiple ocular doses for 12 weeks. The average maximum whole blood concentrations of cyclosporin A ( $C_{max}$ ) were less than 0.2 ng/mL.

### Conclusions

Cyclosporine ophthalmic emulsion in concentrations of 0.05%, 0.1%, 0.2%, and 0.4% applied twice daily was found to be effective, safety, and well tolerated for the treatment of moderate to severe dry eyes with or without Sjögren's syndrome. Efficacy was not dose-related, suggesting that a plateau response was achieved at the lower concentrations tested. While 0.1% cyclosporine ophthalmic emulsion produced the most consistent improvement overall for objective and subjective endpoints, 0.05% cyclosporine ophthalmic emulsion was effective in improving subjective patient symptoms. No additional efficacy benefit was evident with the higher concentrations, 0.2% and 0.4%. Consequently, 0.05% and 0.1% cyclosporine ophthalmic emulsions were selected for the subsequent Phase 3 clinical trials.

#### 3.7.3.4 Phase 3 Study Design

Phase 3 studies 002 and 003 had an identical study design except for the inclusion of pharmacokinetic evaluations in study 002.

### Objective

To evaluate the safety and efficacy of cyclosporine 0.05% and 0.1% ophthalmic emulsions compared with vehicle in patients with moderate to severe KCS.

### Design

These were multicenter, double-masked, randomized, vehicle-controlled, parallel-group studies. During the 2-week Run-in Phase, patients instilled REFRESH<sup>®</sup> artificial tears daily as needed. Patients were randomized and, during the 6-month Vehicle-Controlled Masked Treatment Phase, instilled one drop of cyclosporine emulsion 0.05%, 0.1%, or vehicle into each eye BID, and also used REFRESH<sup>®</sup> as needed until month 4, when they were encouraged to use REFRESH<sup>®</sup> less than 8 times daily until month 12. During the ongoing 6-month Cyclosporine Treatment Extension Phase, patients who received 0.05% or 0.1% cyclosporine continue on the same regimen, while vehicle-treated patients are switched to 0.1% cyclosporine. Visits were at screening, day 0 (baseline), and months 1, 3, 4, 6, and 12. Results for the 6-month Vehicle-Controlled Masked Treatment Phase are presented in this NDA.

### Study Population

Key inclusion criteria were Schirmer (without anesthesia)  $\leq 5$  mm/5 min in at least one eye; if 0 mm/5 min, then Schirmer with nasal stimulation  $\geq 3$  mm/5 min in the same eye **AND** sum of corneal and interpalpebral conjunctival staining  $\geq +5$  in the same eye where corneal staining  $\geq +2$  **AND** at least 9 responses on the OSDI<sup>®</sup> questionnaire other than “not applicable” and responses were in a combination to achieve the minimum required entry score **AND** Facial Expression Subjective Rating Scale  $\geq 3$ . Key exclusion criteria were uncontrolled systemic disease or any significant illness; active ocular disease, corneal disorder or abnormality; active ocular infection or non-KCS inflammation; ophthalmic surgery or trauma; occlusion of the lacrimal puncta; and use of topical or systemic cyclosporine.

### Evaluation Criteria

Objective efficacy endpoints were corneal and interpalpebral conjunctival staining, Schirmer tear test with and without anesthesia, and tear break-up time. Subjective efficacy endpoints were OSDI<sup>®</sup> score, Facial Expression Subjective Rating Scale, symptoms of dry eye, investigator’s evaluation of global response to treatment, and treatment success. In addition, a

responder analysis used 4 of these efficacy parameters. Tertiary ophthalmic tests (results reported separately from the study reports) included mRNA levels for inflammatory cytokine interleukin-6 (IL-6), conjunctival biopsy to evaluate lymphocytic infiltrates, conjunctival goblet cell density, and tear osmolality. In study 002 only, pharmacokinetic measures were blood cyclosporin A trough concentrations, and blood and tear cyclosporin A area under the curve (AUC) evaluations only after 9 to 12 months during the Cyclosporine Treatment Extension Phase. Safety measures were adverse events, visual acuity (by the Early Treatment of Diabetic Retinopathy Study chart), IOP, and biomicroscopy. Because no changes from baseline were observed in any blood chemistry or hematology parameters and no ocular infections occurred in the Phase 2 study, the Sponsor and Food and Drug Administration (FDA) concurred that these endpoints did not need to be included in the Phase 3 studies.

#### Statistical Methods

Data from all patients receiving study medication were included in the ITT analyses for safety and efficacy. Missing efficacy values were imputed using the last observation carried forward. Continuous variables, such as all staining scores and the OSDI<sup>®</sup> score, were analyzed by 2-way analysis of variance. Categorical variables, such as the Facial Expression Subjective Rating Scale, categorized Schirmer values, and symptoms of dry eye, were analyzed by the Cochran-Mantel-Haenszel test with modified ridits, stratified by investigator. Adverse event data were summarized by frequency tables. Two-sided tests with P values  $\leq 0.05$  were considered statistically significant for all analyses.

#### 3.7.3.5 Phase 3 Patient Disposition and Demographics

In study 002, 14 US sites enrolled 405 patients, 135 in the 0.05% cyclosporine group, 134 in the 0.1% cyclosporine group, and 136 in the vehicle group. The majority of patients (75.6%, 306/405) completed the 6-month Vehicle-Controlled Masked Treatment Phase. Among the 24.4% (99/405) of patients who discontinued the study prematurely, 0.5% (2/405) did so due to lack of efficacy, 7.4% (30/405) due to adverse events, and 16.5% (67/405) for other reasons.

In study 003, 24 US sites enrolled 472 patients, 158 in the 0.05% cyclosporine group, 158 in the 0.1% cyclosporine group, and 156 in the vehicle group. The majority of patients (77.3%, 365/472) completed the 6-month Vehicle-Controlled Masked Treatment Phase. Among the



22.7% (107/472) of patients who discontinued the study prematurely, 1.1% (5/472) did so due to lack of efficacy, 6.6% (31/472) due to adverse events, and 15.0% (71/472) for other reasons.

Patient demographics for each of the Phase 3 studies are summarized in Table 3.7.3.5. There were no statistically significant differences among the treatment groups in either study for these parameters (NDA Sections 8.11.1 and 8.11.2, Attachment 13.1, Tables 4 and 5).

**Table 3.7.3.5 Phase 3 Studies: Summary of Demographics (ITT Population)**

Parameter	Study 192371-002			Study 192371-003		
	CsA 0.05%	CsA 0.1%	Vehicle	CsA 0.05%	CsA 0.1%	Vehicle
Age, N	135	134	136	158	158	156
Mean (SD), years	58.3	59.2	60.5	59.1	60.8	59.3
Range	22.8 - 90.3	21.6 - 86.7	24.7 - 88.8	24.0 - 86.5	28.1 - 89.0	27.5 - 90.3
Race, N (%)						
Caucasian	107 (79.3)	103 (76.9)	102 (75.0)	146 (92.4)	140 (88.6)	142 (91.0)
Black	4 ( 3.0)	7 ( 5.2)	9 ( 6.6)	4 ( 2.5)	9 ( 5.7)	6 ( 3.8)
Asian	5 ( 3.7)	5 ( 3.7)	6 ( 4.4)	3 ( 1.9)	1 ( 0.6)	0 ( 0.0)
Hispanic	18 (13.3)	19 (14.2)	18 (13.2)	5 ( 3.2)	7 ( 4.4)	8 ( 5.1)
Other	1 ( 0.7)	0 ( 0.0)	1 ( 0.7)	0 ( 0.0)	1 ( 0.6)	0 ( 0.0)
Sex, N (%)						
Male	21 (15.6)	31 (23.1)	35 (25.7)	28 (17.7)	23 (14.6)	24 (15.4)
Female	114 (84.4)	103 (76.9)	101 (74.3)	130 (82.3)	135 (85.4)	132 (84.6)
Iris Color, N (%)						
Blue	41 (30.4)	37 (27.6)	45 (33.1)	56 (35.4)	58 (36.7)	64 (41.0)
Brown	65 (48.1)	64 (47.8)	66 (48.5)	61 (38.6)	63 (39.9)	50 (32.1)
Green	7 ( 5.2)	14 (10.4)	3 ( 2.2)	13 ( 8.2)	12 ( 7.6)	15 ( 9.6)
Hazel	22 (16.3)	18 (13.4)	22 (16.2)	26 (16.5)	20 (12.7)	24 (15.4)
Black	0 ( 0.0)	0 ( 0.0)	0 ( 0.0)	0 ( 0.0)	2 ( 1.3)	0 ( 0.0)
Other	0 ( 0.0)	1 ( 0.7)	0 ( 0.0)	2 ( 1.3)	3 ( 1.9)	3 ( 1.9)
Sjogren's patient <sup>a</sup>	28.1% (38/135)	29.1% (39/134)	27.2% (37/136)	36.7% (58/158)	27.8% (44/158)	34.6% (54/156)

Note: CsA = cyclosporine ophthalmic emulsion, SD = standard deviation

a Percentage (number) of patients with a positive response for ocular symptoms, oral symptoms, and Schirmer, and a positive response for at least one of the autoantibodies (ANA, RF, Sjogren A, Sjogren B).

### 3.7.3.6 Phase 3 Intent-to-Treat Analysis of Efficacy Results

In the ITT analysis, all patients who received at least 1 dose of study medication were counted in the treatment group to which they were randomized. For all efficacy variables collected on both eyes, only the worse eye was analyzed, defined as the eye having the worse Schirmer (without anesthesia) and sum of corneal and interpalpebral conjunctival staining at baseline. If there was no visit within the per-protocol visit window, then the last available observation was carried

forward and used in the analysis. Day 0 data (ie, baseline data prior to study medication) were not carried forward. All month 6 data were used, even if the visit occurred outside the visit window.

The primary focus of this summary of the efficacy results is the objective parameters corneal staining and Schirmer tear test with anesthesia, and the subjective endpoints blurred vision and REFRESH® use.

### Objective Efficacy Measures

**Corneal Staining:** Ocular staining was evaluated using the Oxford 6-point severity scale, which uses diagrams illustrating increasing severity (grades 0 to 5) to assist in standardizing grading by investigators. Staining was analyzed as change from baseline for the worse eye, with a negative change indicating improvement.

Corneal staining is summarized for each of the Phase 3 studies in Table 3.7.3.6-1 (NDA Sections 8.11.2 and 8.11.3, Attachment 13.1, Table 12.1).

**Table 3.7.3.6-1 Corneal Fluorescein Staining in Phase 3 Studies (Intent-to-Treat Population)**

	Study 192371-002				Study 192371-003			
	CsA 0.05% N=135 <sup>a</sup>	CsA 0.1% N=134 <sup>a</sup>	Vehicle N=136 <sup>a</sup>	P value <sup>b</sup>	CsA 0.05% N=158 <sup>a</sup>	CsA 0.1% N=158 <sup>a</sup>	Vehicle N=156 <sup>a</sup>	P value <sup>b</sup>
Day 0	2.84 ± 0.74	2.73 ± 0.82	2.72 ± 0.74	0.732	2.72 ± 0.85	2.70 ± 0.82	2.52 ± 0.73	0.036 <sup>d</sup>
Change from baseline <sup>c</sup> :								
Month 1	-0.53 ± 0.91	-0.41 ± 0.92	-0.34 ± 0.91	0.273	-0.71 ± 0.84	-0.80 ± 0.85	-0.68 ± 0.84	0.397
Month 3	-0.56 ± 0.93	-0.39 ± 1.04	-0.29 ± 0.88	0.152	-0.66 ± 0.87	-0.79 ± 0.92	-0.62 ± 0.93	0.243
Month 4	-0.62 ± 0.97	-0.55 ± 1.05	-0.38 ± 0.94	0.136	-0.72 ± 0.92	-0.87 ± 1.01	-0.63 ± 1.01	0.091
Month 6	-0.94 ± 1.01	-0.73 ± 1.08	-0.51 ± 1.03	0.008 <sup>e</sup>	-0.84 ± 0.97	-0.93 ± 1.00	-0.78 ± 1.02	0.394

Note: CsA = cyclosporine ophthalmic emulsion. Values shown are mean ± standard deviation. Based on a 6-point severity scale (grades 0 to 5) using the worse eye. A negative change indicates improvement.

- a The number of patients at day 0; sample sizes decreased at subsequent visits.
- b Among-group P values from analysis of variance.
- c Within-group P values (from paired t-test) for change from baseline were significant (P < 0.001) for all treatment groups at all visits in both studies.
- d Pairwise comparisons (from analysis of variance) showed higher baseline values for 0.05% and 0.1% CsA vs vehicle.
- e Pairwise comparisons (from analysis of variance) favored 0.05% CsA vs vehicle.

There were statistically significant improvements from baseline in each treatment group at each visit in each study. Within each study, the improvement with either concentration of cyclosporine emulsion was greater than that with vehicle at all time points.

In study 002, improvement was consistently greatest with 0.05% cyclosporine emulsion, and the among-group difference at month 6 was statistically significant, favoring 0.05% cyclosporine emulsion vs vehicle.

In study 003, improvement was consistently greatest with 0.1% cyclosporine emulsion. The vehicle group had significantly lower (milder) corneal staining at baseline and improvement with vehicle was notable as early as month 1.

*Schirmer Tear Test with Anesthesia:* This test was performed at baseline, month 3 and month 6 only. The Food and Drug Administration (FDA) requested that Schirmer values be evaluated by category. Accordingly, the Sponsor categorized Schirmer values from grade 1 (< 3 mm/5 min) to grade 5 (≥ 15 mm/5 min) for analysis. A positive change from baseline indicated improvement. Results of the Schirmer tear test with anesthesia are summarized for each of the Phase 3 studies in Table 3.7.3.6-2 (NDA Sections 8.11.2 and 8.11.3, Attachment 13.1, Table 16.2).

**Table 3.7.3.6-2 Categorized Schirmer Values With Anesthesia in Phase 3 Studies (Intent-to-Treat Population)**

	Study 192371-002				Study 192371-003			
	CsA 0.05% N=135 <sup>a</sup>	CsA 0.1% N=134 <sup>a</sup>	Vehicle N=136 <sup>a</sup>	P value <sup>b</sup>	CsA 0.05% N=158 <sup>a</sup>	CsA 0.1% N=158 <sup>a</sup>	Vehicle N=156 <sup>a</sup>	P value <sup>b</sup>
Day 0	2.10 ± 0.94	2.26 ± 1.06	2.23 ± 1.07	0.463	1.81 ± 0.95	1.90 ± 0.87	2.00 ± 1.03	0.221
Change from baseline:								
Month 3	0.07 ± 1.37	-0.17 ± 1.53	-0.26 ± 1.53	0.100	0.08 ± 1.33	-0.04 ± 1.31	-0.20 ± 1.26	0.237
Month 6	0.41 ± 1.42 <sup>c</sup>	0.21 ± 1.36	0.02 ± 1.43	0.066	0.36 ± 1.42 <sup>c</sup>	0.31 ± 1.26 <sup>c</sup>	-0.18 ± 1.06 <sup>c</sup>	<0.001 <sup>d</sup>

Note: CsA = cyclosporine ophthalmic emulsion. Values shown are mean ± standard deviation. Schirmer values categorized as 1 (< 3 mm/5 min), 2 (3 to 6 mm/5 min), 3 (7 to 10 mm/5 min), 4 (11 to 14 mm/5 min), and 5 (> 14 mm/5 min) using the worse eye. A positive change indicates improvement.

a The number of patients at day 0; sample sizes decreased at subsequent visits.

b Among-group P values from Cochran-Mantel-Haenszel test.

c Significant within-group P values (from Wilcoxon's signed-rank test) for change from baseline (P ≤ 0.048).

d Pairwise comparisons (from Cochran-Mantel-Haenszel test) favored 0.05% and 0.1% CsA vs vehicle.

In study 002 at month 6, there was statistically significant improvement from baseline with 0.05% cyclosporine emulsion. The among-group difference approached statistical significance at month 6 with the greatest improvement shown in the 0.05% group in contrast to almost no change with vehicle.

In study 003 at month 6, there were statistically significant improvements with either concentration of cyclosporine emulsion in contrast to a significant worsening with vehicle; the among-group difference was statistically significant in favor of cyclosporine emulsion over vehicle.

In both studies, improvement at month 6 was greatest with 0.05% cyclosporine emulsion.

*Other Objective Parameters:* Statistically significant improvement from baseline was generally seen in each study within each of the 3 treatment groups at every visit. In each study, no statistically significant among-group differences were found for temporal interpalpebral conjunctival staining, nasal interpalpebral conjunctival staining, the sum of temporal and nasal interpalpebral conjunctival staining, the sum of corneal and conjunctival staining, and Schirmer values without anesthesia.

#### Subjective Efficacy Measures

*Blurred Vision:* In the Phase 3 studies, patients evaluated 7 specific dry-eye symptoms by completing a questionnaire at the study site and grading each symptom from 0 (do not have this symptom) to 4 (always notice this symptom). A negative change from baseline indicated improvement. Results for the symptom blurred vision are summarized for each of the Phase 3 studies in Table 3.7.3.6-3 (NDA Sections 8.11.2 and 8.11.3, Attachment 13.1, Table 15.8).

**Table 3.7.3.6-3 Blurred Vision in Phase 3 Studies (Intent-to-Treat Population)**

	Study 192371-002				Study 192371-003			
	CsA 0.05% N=135 <sup>a</sup>	CsA 0.1% N=134 <sup>a</sup>	Vehicle N=136 <sup>a</sup>	P value <sup>b</sup>	CsA 0.05% N=158 <sup>a</sup>	CsA 0.1% N=158 <sup>a</sup>	Vehicle N=156 <sup>a</sup>	P value <sup>b</sup>
Day 0	2.22 ± 1.30	1.95 ± 1.27	1.85 ± 1.22	0.045 <sup>d</sup>	1.89 ± 1.32	1.85 ± 1.28	1.81 ± 1.35	0.852
Change from baseline:								
Month 1	-0.33 ± 0.98 <sup>c</sup>	-0.18 ± 1.08	-0.02 ± 0.94	0.071	-0.31 ± 1.05 <sup>c</sup>	-0.17 ± 1.11	-0.12 ± 1.26	0.210
Month 3	-0.55 ± 1.13 <sup>c</sup>	-0.16 ± 1.10	0.03 ± 1.05	<0.001 <sup>c</sup>	-0.34 ± 1.18 <sup>c</sup>	-0.22 ± 1.18 <sup>c</sup>	-0.22 ± 1.41	0.568
Month 4	-0.57 ± 1.28 <sup>c</sup>	-0.18 ± 1.10	-0.08 ± 1.09	0.003 <sup>c</sup>	-0.24 ± 1.15 <sup>c</sup>	-0.19 ± 1.20 <sup>c</sup>	-0.09 ± 1.43	0.887
Month 6	-0.55 ± 1.37 <sup>c</sup>	-0.39 ± 1.18 <sup>c</sup>	-0.22 ± 1.08 <sup>c</sup>	0.127	-0.41 ± 1.19 <sup>c</sup>	-0.38 ± 1.27 <sup>c</sup>	-0.08 ± 1.46	0.263

Note: CsA = cyclosporine ophthalmic emulsion. Values shown are mean ± standard deviation. Graded on a scale from 0 (do not have symptom) to 4 (always notice symptom). A negative change indicates improvement.

- a The number of patients at day 0; sample sizes decreased at subsequent visits.
- b Among-group P values from Cochran-Mantel-Haenszel test.
- c Significant within-group P values (from Wilcoxon's signed-rank test) for change from baseline ( $P \leq 0.042$ ).
- d Pairwise comparisons (from Cochran-Mantel-Haenszel test) showed higher baseline values for 0.05% CsA vs vehicle.
- e Pairwise comparisons (from Cochran-Mantel-Haenszel test) favored 0.05% vs 0.1% CsA and vehicle.

In study 002, there were statistically significant improvements from baseline in blurred vision with 0.05% cyclosporine emulsion at each visit. Improvement was greater with either concentration of cyclosporine emulsion than with vehicle at each visit (consistently greatest with 0.05%), with statistically significant among-group differences favoring 0.05% cyclosporine vs vehicle at months 3 and 4.

In study 003, statistically significant improvement from baseline was seen with both concentrations of cyclosporine emulsion (consistently greatest with 0.05% cyclosporine emulsion) but not with vehicle.

**REFRESH<sup>®</sup> Use:** This is considered a subjective variable because it was reported by the patients. Mean daily REFRESH<sup>®</sup> use during the previous week is summarized for each of the Phase 3 studies in Table 3.7.3.6-4 (NDA Sections 8.11.2 and 8.11.3, Attachment 13.1, Table 20).

**Table 3.7.3.6-4 Daily REFRESH<sup>®</sup> Use During the Previous Week in Phase 3 Studies (Intent-to-Treat Population)**

	Study 192371-002				Study 192371-003			
	CsA 0.05% N=135 <sup>a</sup>	CsA 0.1% N=134 <sup>a</sup>	Vehicle N=136 <sup>a</sup>	P value <sup>b</sup>	CsA 0.05% N=158 <sup>a</sup>	CsA 0.1% N=158 <sup>a</sup>	Vehicle N=156 <sup>a</sup>	P value <sup>b</sup>
Day 0	5.74 ± 8.33	5.03 ± 3.60	4.54 ± 2.76	0.315	6.69 ± 6.69	6.02 ± 4.63	5.14 ± 3.96	0.019 <sup>f</sup>
Change from baseline:								
Month 1	-1.07 ± 5.27 <sup>c</sup>	-0.58 ± 2.85 <sup>c</sup>	0.39 ± 5.06	0.141	-0.24 ± 8.49	-0.37 ± 4.99	-0.75 ± 4.11 <sup>c</sup>	0.750
Month 3	-1.94 ± 6.86 <sup>c</sup>	-0.64 ± 4.21	0.25 ± 5.11	0.028 <sup>c</sup>	-0.85 ± 7.22	-1.11 ± 5.09 <sup>c</sup>	-0.94 ± 4.37 <sup>c</sup>	0.927
Month 4 <sup>d</sup>	-2.96 ± 6.12 <sup>c</sup>	-1.78 ± 4.23 <sup>c</sup>	-1.41 ± 3.94 <sup>c</sup>	0.099	-2.05 ± 7.13 <sup>c</sup>	-2.01 ± 5.11 <sup>c</sup>	-1.89 ± 6.66 <sup>c</sup>	0.923
Month 6	-1.79 ± 7.12 <sup>c</sup>	-1.23 ± 5.48 <sup>c</sup>	-0.07 ± 5.87	0.124	-2.34 ± 6.05 <sup>c</sup>	-1.51 ± 4.63 <sup>c</sup>	-1.15 ± 6.64 <sup>c</sup>	0.087

Note: CsA = cyclosporine ophthalmic emulsion. Values shown are mean ± standard deviation. Based on patient-estimated times per day that REFRESH<sup>®</sup> was used during the previous week. A negative change indicates improvement.

- a Number of patients at day 0; sample sizes decreased at subsequent visits.
- b Among-group P values from analysis of variance.
- c Significant within-group P values (from paired t-test) for change from baseline ( $P \leq 0.040$ ).
- d Patients were asked to cease using REFRESH<sup>®</sup> during the previous week.
- e Pairwise comparisons (by analysis of variance) favored 0.05% CsA vs vehicle.
- f Pairwise comparisons (by analysis of variance) showed higher baseline value for 0.05% CsA vs vehicle.

In both studies, baseline REFRESH<sup>®</sup> use was higher in the cyclosporine emulsion groups than in the vehicle group. For the week prior to the month 4 visit, patients were instructed to stop using REFRESH<sup>®</sup>, which is reflected in the greater changes from baseline reported at that visit. The greatest decrease in REFRESH<sup>®</sup> use at month 6 was seen with 0.05% cyclosporine emulsion in both studies.

In study 002, the decrease in REFRESH<sup>®</sup> use was greater with either concentration of cyclosporine emulsion than with vehicle at each visit (consistently greater with 0.05%). Among-group differences favoring 0.05% cyclosporine emulsion vs vehicle were statistically significant at month 3 and approached significance at month 4.

In study 003, there was a notable decrease in REFRESH<sup>®</sup> use with vehicle as early as month 1. By month 4, however, the decrease in REFRESH<sup>®</sup> use was greater with either concentration of cyclosporine emulsion than with vehicle. At month 6, the among-group difference approached statistical significance.

*Other Subjective Parameters:* In each study, statistically significant improvement from baseline was generally seen within each of the 3 treatment groups at every visit. In study 002, there were statistically significant among-group differences favoring at least one concentration of cyclosporine emulsion over vehicle for blurred vision at months 3 and 4; sensitivity to light at months 4 and 6; itching at months 3, 4, and 6; composite symptom severity score at months 3 and 6; OSDI<sup>®</sup> at months 3 and 4; and Facial Expression Subjective Rating Scale at months 3 and 6. In study 003, among-group differences for other subjective parameters were not statistically significant.

### Responder Analysis

An analysis of responders was performed on the ITT population. Responders were defined based on a score comprising results for corneal staining, Schirmer with anesthesia, blurred vision, and REFRESH<sup>®</sup> use. Since Schirmer with anesthesia was only measured at baseline and months 3 and 6, the responder analysis only could be performed for months 3 and 6. The specific definition of a responder is provided in the study reports, and the results of the responder analysis are shown in Table 3.7.3.6.-5 (NDA Sections 8.11.2 and 8.11.3, report section 4.13.3.6 and Attachment 13.1, Table 25).

**Table 3.7.3.6-5 Number (%) of Responders in Phase 3 Studies (Intent-to-Treat Population)**

	Study 192371-002				Study 192371-003			
	CsA 0.05%	CsA 0.1%	Vehicle	P value <sup>a</sup>	CsA 0.05%	CsA 0.1%	Vehicle	P value <sup>a</sup>
Month 3	35% (31/89)	33% (28/85)	29% (25/86)	0.707	40% (41/103)	34% (32/95)	28% (26/94)	0.207
Month 6	50% (58/116)	44% (50/113)	31% (34/109)	0.014 <sup>b</sup>	43% (58/136)	46% (60/130)	29% (38/130)	0.012 <sup>c</sup>

Note: CsA = cyclosporine ophthalmic emulsion. The numerator is the number of responders and the denominator is the number of patients.

- a Among-group P values from Fisher's exact test.
- b Pairwise comparisons (from Fisher's exact test) favored 0.05% vs vehicle and approached significance for 0.1% CsA vs vehicle (P = 0.053).
- c Pairwise comparisons (from Fisher's exact test) favored 0.05% and 0.1% vs vehicle.

In each study, close to 50% of cyclosporine patients were classified as responders compared to only 30% of vehicle patients, a statistically significant difference. In study 002, there was a significantly greater proportion of responders with 0.05% cyclosporine than with vehicle and the

difference between 0.1% cyclosporine and vehicle approached statistical significance (P = 0.053). In study 003, there was a significantly greater proportion of responders with both concentrations of cyclosporine emulsion than with vehicle.

Meta-Analysis

A meta-analysis of the ITT population in studies 002 and 003 was performed to confirm that statistically and clinically relevant improvement in signs and symptoms with cyclosporine ophthalmic emulsion would be apparent in the enrolled patient population overall. The meta-analysis was performed by combining all ITT data from both Phase 3 studies, and pooling investigators by geographic region within each of the Phase 3 studies.

The statistically significant among-group differences in the meta-analysis are summarized in Table 3.7.3.6-6 (Tables 1 to 9, NDA Section 8.6.13).

**Table 3.7.3.6-6 Statistically Significant Among-Group Differences in the Meta-Analysis of Phase 3 Studies (Intent-to-Treat Population)**

Parameter	Statistically Significant Among-Group Differences <sup>a</sup>	Statistically Significant Pairwise Comparisons Favored:
Corneal staining	Month 4 (P = 0.043) Month 6 (P = 0.023)	0.05% and 0.1% CsA vs vehicle 0.05% CsA vs vehicle
Categorized Schirmer with anesthesia	Month 3 (P = 0.030) Month 6 (P < 0.001)	0.05% CsA vs vehicle 0.05% and 0.1% CsA vs vehicle
Blurred vision	Month 1 (P = 0.018) Month 3 (P = 0.002) Month 4 (P = 0.028) Month 6 (P = 0.044)	0.05% CsA vs vehicle 0.05% CsA vs vehicle 0.05% CsA vs vehicle 0.05% CsA vs vehicle
REFRESH <sup>®</sup> use	Day 0 (P = 0.008) Month 6 (P = 0.013)	0.05% and 0.1% CsA higher than vehicle 0.05% CsA vs vehicle
Global response to treatment <sup>b</sup>	Month 3 (P = 0.018) Month 4 (P = 0.021)	0.1% CsA vs 0.05% CsA & vehicle 0.1% CsA vs vehicle
Burning/Stinging	Day 0 (P = 0.018)	0.05% and 0.1% CsA higher than vehicle
Treatment success <sup>c</sup>	Month 6 (P = 0.041)	0.05% CsA vs 0.1% CsA & vehicle

Note: CsA = cyclosporine ophthalmic emulsion.

- a Among-group P values from analysis of variance (for staining and REFRESH<sup>®</sup> use) and Cochran-Mantel-Haenszel test (for Schirmer test, symptoms, and global response), and Fisher's exact test (for treatment success).
- b Investigator's evaluation of global response to treatment was classified on a 7-point scale, from condition worsened to condition improved approximately 100% (completely cleared).
- c The number of patients who had a global response of almost cleared or completely cleared.



The meta-analysis found statistically significant among-group differences in favor of 0.05% cyclosporine emulsion in the key efficacy parameters of corneal staining, categorized Schirmer with anesthesia, blurred vision, and REFRESH<sup>®</sup> use. Within-group differences with either concentration of cyclosporine emulsion were statistically significant for most efficacy parameters (except for burning/stinging, pain, Schirmer at month 3 and REFRESH<sup>®</sup> use at month 1). Thus, the meta-analysis confirmed that the statistically and clinically relevant improvement from baseline in signs and symptoms seen in the individual studies were apparent in the Phase 3 patient population overall.

#### Subgroup Analyses

To further confirm the efficacy of cyclosporine emulsion as seen in the ITT analysis, subgroup analyses were performed in patients with severe disease, in the per-protocol subgroup, in patients with Sjögren's syndrome, by age category, by race category, by sex, and by iris color. In each study there were general similarities between the ITT and the subgroup analyses. In the per-protocol analysis in study 002, a more defined dose-response pattern for most variables developed by month 6 than in the ITT analysis. In the severe subgroup in study 003, there were statistically significant among-group differences favoring cyclosporine over vehicle for corneal staining at months 4 and 6, and the difference approached statistical significance at month 6 for blurred vision. Results from these analyses established that the efficacy of cyclosporine emulsion is not limited to a specific subgroup.

#### 3.7.3.7 Results of Phase 3 Tertiary Ophthalmic Tests

Procedures for all tertiary tests were conducted in the worse eye, identified by the investigator at the qualification examination based upon results of the Schirmer test without anesthesia and corneal and interpalpebral conjunctival staining. Further details on these tests, particularly regarding the methods, are provided in the individual reports (Tertiary Reports, 1999; NDA Sections 8.11.6 to 8.11.9).

#### Inflammatory Cytokine IL-6 Levels

The presence of proinflammatory cytokines on the ocular surface of dry-eye patients is a direct indicator of disease. The proinflammatory cytokine IL-6 was measured by mRNA expression in superficial conjunctival epithelium in study 003. It was hypothesized that treatment of KCS with cyclosporine ophthalmic emulsion would decrease the level of IL-6 in dry-eye patients

relative to the level of G3PDH, a housekeeping gene that is expressed at the same relative level in all cells and that served as a positive control.

The principal outcome variable was the G3PDH-normalized level of IL-6 and results are presented in Table 3.7.3.7-1 (Tertiary report: Pflugfelder, 1999; NDA Section 8.11.6).

**Table 3.7.3.7-1 Normalized IL-6: Baseline Data and Change from Baseline at Months 3 and 6**

Time	CsA 0.05%	CsA 0.1%	Vehicle	P value <sup>a</sup>
Day 0	1.144 ± 1.005 N = 14	1.401 ± 1.198 N = 12	0.846 ± 0.663 N = 10	0.438
Change from baseline:				
Month 3 P value <sup>b</sup>	0.036 ± 0.643 (N = 10) P = 0.862	-0.095 ± 1.430 (N = 10) P = 0.839	2.269 ± 5.524 (N = 7) P = 0.319	0.221
Month 6 P value <sup>b</sup>	-0.626 ± 1.025 (N = 13) P = 0.048	-0.384 ± 1.248 (N = 8) P = 0.413	-0.460 ± 0.749 (N = 10) P = 0.084	0.853

Note: CsA = cyclosporine ophthalmic emulsion, N = number of patients. Values shown are mean ± standard deviation for mimic corrected ratios of IL-6 to G3PDH. A negative value indicates a decrease from baseline.

a Among-group P values from one-way analysis of variance.

b Within-group P values from paired-t-test.

IL-6 was found in conjunctival epithelial samples from patients in all 3 treatment groups at baseline. At month 6, this small cohort showed a statistically significant decrease in normalized IL-6 in the conjunctival epithelium of KCS patients treated with 0.05% cyclosporine emulsion. This finding suggests an anti-inflammatory action of 0.05% cyclosporine emulsion in KCS patients.

#### Lymphocytic and Immune Activation Markers from Conjunctival Biopsies

Conjunctival biopsies were taken from a subset of patients in studies 002 and 003 for histological evaluation and immunohistochemical evaluation of monoclonal antibodies for cell surface markers to determine the presence and activation of T cells (CD3, CD4, and CD8), the receptor for ICAM-1 (CD11a), and the immune activation marker HLA-DR. It was hypothesized that treatment with cyclosporine emulsion would reduce inflammation in the conjunctiva, as shown by a decrease in the numbers of lymphocytes and immune activation markers.

Data were available from 32 patients, most of whom (30/32) were from the 2 sites in study 003. Baseline data and the percent change at month 6 for lymphocytic and immune activation markers are presented in Table 3.7.3.7-2 (Tertiary report: Gipson, 1999; NDA Section 8.11.7).

**Table 3.7.3.7-2 Lymphocytic and Immune-Activation Markers: Baseline Data and Percent Change at Month 6**

Parameter Time	CsA 0.05 % N = 13	CsA 0.1 % N = 6	Vehicle N = 13	P value <sup>a</sup>
<b>CD3</b> Day 0 Month 6 (% change) Within-group P value <sup>b</sup>	2291.2 ± 2393.5 -20.7 ± 94.5 P = 0.444	1298.5 ± 782.3 -37.7 ± 59.9 P = 0.184	1573.5 ± 1300.8 52.1 ± 216.0 P = 0.401	0.444 0.371
<b>CD4</b> Day 0 Month 6 (% change) Within-group P value <sup>b</sup>	1252.5 ± 1449.5 28.5 ± 231.6 P = 0.665	558.2 ± 372.1 -17.3 ± 87.3 P = 0.647	1195.1 ± 1097.3 85.7 ± 266.5 P = 0.269	0.466 0.638
<b>CD8</b> Day 0 Month 6 (% change) Within-group P value <sup>b</sup>	1126.8 ± 1142.3 -7.8 ± 94.0 P = 0.770	990.2 ± 358.6 -5.9 ± 77.2 P = 0.858	1093.1 ± 852.7 11.4 ± 117.7 P = 0.732	0.956 0.879
<b>CD11a</b> Day 0 Month 6 (% change) Within-group P value <sup>b</sup>	2520.1 ± 2770.9 -11.2 ± 86.1 P = 0.646	1184.0 ± 325.5 -44.2 ± 52.7 P = 0.095	1763.6 ± 1301.3 103.7 ± 184.9 P = 0.066	0.362 0.042 <sup>c</sup>
<b>HLA-DR</b> Day 0 Month 6 (% change) Within-group P value <sup>b</sup>	2001.2 ± 2495.0 -34.0 ± 53.0 P = 0.039	414.5 ± 516.0 -68.4 ± 54.2 P = 0.086	1166.0 ± 1372.6 160.1 ± 264.4 P = 0.060	0.210 0.019 <sup>d</sup>

Note: CsA = cyclosporine ophthalmic emulsion. Values shown are mean ± standard deviation for cells/mm<sup>2</sup> on day 0 and % change from baseline at month 6. A negative value indicates a decrease from baseline.  
a Among-group P values from one-way analysis of variance.  
b Within-group P value from paired t-test.  
c Pairwise comparisons (from one-way analysis of variance) were not statistically significant; P = 0.053 for 0.05% CsA vs vehicle and P = 0.075 for 0.1% CsA vs vehicle.  
d Pairwise comparisons (from one-way analysis of variance) favored 0.05% CsA vs vehicle.

The lymphocytic markers CD3, CD4, and CD8 tended to decrease after 6-month treatment with cyclosporine emulsion (except for CD4 with 0.05% cyclosporine emulsion) compared to increases with vehicle. CD11a and HLA-DR decreased after 6-month treatment with 0.05% and 0.1% cyclosporine emulsion, reaching statistical significance for HLA-DR with 0.05% cyclosporine emulsion, compared to marked increases with vehicle. Among-group differences

were statistically significant for both parameters, favoring 0.05% cyclosporine emulsion vs vehicle.

These data suggest that treatment of KCS patients with cyclosporine emulsion decreases the inflammatory response and immune reactivity.

#### Goblet Cell Density from Conjunctival Biopsies

In severe KCS, the conjunctival epithelium shows characteristic changes, including a reduction in goblet cell numbers (Ralph, 1975; Gilbard, 1986; Pflugfelder et al, 1997). It was hypothesized that treatment of KCS with cyclosporine ophthalmic emulsion could restore the density of goblet cells.

Baseline data and the percent change at month 6 are presented in Table 3.7.3.7-3 (Tertiary report: Gipson, 1999; NDA Section 8.11.7).

**Table 3.7.3.7-3 PAS/Goblet Cell Density from Conjunctival Biopsy: Baseline Data and Percent Change at Month 6**

	<b>CsA 0.05 %</b>	<b>CsA 0.1 %</b>	<b>Vehicle</b>	<b>P value<sup>a</sup></b>
Day 0	114.2 ± 104.2 (N = 12)	127.5 ± 28.5 (N = 4)	124.9 ± 155.1 (N = 12)	0.971
Month 6 (% change) P value <sup>b</sup>	191.1 ± 213.8 (N = 11) P = 0.014	-22.4 ± 36.9 (N = 4) P = 0.312	13.3 ± 80.1 (N = 12) P = 0.576	0.013 <sup>c</sup>

Note: PAS = periodic acid-Schiff staining, CsA = cyclosporine ophthalmic emulsion. Values shown are mean ± standard deviation. Day 0 values are cells/0.1 mm<sup>2</sup> of epithelium. A negative value indicates a decrease from baseline.

- a Among-group P values from one-way analysis of variance.
- b Within-group P value from paired-t-test.
- c Pairwise comparisons (from one-way analysis of variance) favored 0.05% CsA vs vehicle.

At month 6, there was a statistically significant 191% increase (P = 0.014) with 0.05% cyclosporine emulsion compared to a 13% increase with vehicle and a 22% decrease with 0.1% cyclosporine emulsion. The different response with the 0.1% cyclosporine concentration could be due to the small number of samples (N = 4). The among-group difference was statistically significant at month 6, favoring 0.05% cyclosporine emulsion vs vehicle. This is a clinically relevant finding that reflects improvement of the ocular surface, and supports the hypothesis that the effect of cyclosporine on the underlying mechanisms of dry-eye disease results in improvement of the ocular surface.

### 3.7.3.8 Phase 3 Pharmacokinetics Results

In study 002, trough blood concentrations of cyclosporin A were below the limit of quantitation of 0.1 ng/mL at all visits for all patients in the vehicle group (112 samples) and for all patients in the 0.05% cyclosporine group (113 samples). Trough blood concentrations of cyclosporin A were quantifiable in only 6 of 113 samples from 6 different patients in the 0.1% cyclosporine group; the highest concentration reported was 0.299 ng/mL.

### 3.7.3.9 Phase 3 Safety Results

#### Extent of Exposure

At the end of the 6-month Vehicle-Control Masked Treatment Phase, the median duration of exposure to study medication in study 002 was 177 days, with 93.8% (380/405) of the patients exposed for at least 28 days and 73.3% (297/405) for at least 168 days. The median duration of exposure study 003 was 181 days, with 96.2% (454/472) of the patients exposed for at least 28 days and 75.4% (356/472) for at least 168 days.

#### Adverse Events

In each treatment group in each study, approximately 60% of patients experienced one or more adverse events, regardless of causality. The incidence of adverse events by body system is summarized in Table 3.7.3.9-1 (192371-002 and 192371-003 clinical study reports, Table 29).

**Table 3.7.3.9-1 Number (%) of Patients in the Phase 3 Studies with Adverse Events Overall and by Body System (Intent-to-Treat Population)**

COSTART body system	Study 192371-002			Study 192371-003		
	CsA 0.05% N=135	CsA 0.1% N=134	Vehicle N=136	CsA 0.05% N=158	CsA 0.1% N=158	Vehicle N=156
Overall	72 (53.3)	87 (64.9)	82 (60.3)	94 (59.5)	97 (61.4)	87 (55.8)
Body as a whole	24 (17.8)	18 (13.4)	32 (23.5)	31 (19.6)	33 (20.9)	31 (19.9)
Cardiovascular	5 ( 3.7)	8 ( 6.0)	9 ( 6.6)	14 ( 8.9)	11 ( 7.0)	5 ( 3.2)
Digestive	11 ( 8.1)	6 ( 4.5)	12 ( 8.8)	15 ( 9.5)	16 (10.1)	12 ( 7.7)
Endocrine	0 ( 0.0)	2 ( 1.5)	0 ( 0.0)	1 ( 0.6)	2 ( 1.3)	1 ( 0.6)
Hemic and lymphatic	4 ( 3.0)	2 ( 1.5)	0 ( 0.0)	1 ( 0.6)	1 ( 0.6)	1 ( 0.6)
Metabolic and nutritional	6 ( 4.4)	4 ( 3.0)	2 ( 1.5)	1 ( 0.6)	4 ( 2.5)	2 ( 1.3)
Musculoskeletal	2 ( 1.5)	4 ( 3.0)	6 ( 4.4)	8 ( 5.1)	10 ( 6.3)	7 ( 4.5)
Nervous	5 ( 3.7)	3 ( 2.2)	5 ( 3.7)	7 ( 4.4)	7 ( 4.4)	2 ( 1.3)
Respiratory	7 ( 5.2)	17 (12.7)	19 (14.0)	20 (12.7)	16 (10.1)	21 (13.5)
Skin	5 ( 3.7)	5 ( 3.7)	9 ( 6.6)	10 ( 6.3)	9 ( 5.7)	7 ( 4.5)
Special senses	47 (34.8)	59 (44.0)	42 (30.9)	55 (34.8)	64 (40.5)	47 (30.1)
Urogenital	5 ( 3.7)	9 ( 6.7)	7 ( 5.1)	7 ( 4.4)	3 ( 1.9)	7 ( 4.5)

Note: CsA = cyclosporine ophthalmic emulsion. Special senses includes ocular adverse events.

The body systems most often affected were special senses, which includes ocular events, body as a whole, and respiratory. Ocular adverse events reported by 3% or more of patients in any treatment group in a study are summarized in Table 3.7.3.9-2 (listed alphabetically) (192371-002 and 192371-003 clinical study reports, Table 29).

**Table 3.7.3.9-2 Number (%) of Patients in the Phase 3 Studies with Ocular Adverse Events Reported by  $\geq 3\%$  of Patients in a Treatment Group (Intent-to-Treat Population)**

COSTART body system	Study 192371-002			Study 192371-003		
	CsA 0.05% N=135	CsA 0.1% N=134	Vehicle N=136	CsA 0.05% N=158	CsA 0.1% N=158	Vehicle N=156
Burning eye	23 (17.0)	29 (21.6)	12 ( 8.8)	24 (15.2)	22 (13.9)	9 ( 5.8)
Conjunctival hyperemia	2 ( 1.5)	4 ( 3.0)	1 ( 0.7)	9 ( 5.7)	8 ( 5.1)	1 ( 0.6)
Discharge eye	5 ( 3.7)	4 ( 3.0)	3 ( 2.2)	9 ( 5.7)	3 ( 1.9)	5 ( 3.2)
Epiphora	1 ( 0.7)	5 ( 3.7)	0 ( 0.0)	2 ( 1.3)	3 ( 1.9)	4 ( 2.6)
Foreign body sensation	7 ( 5.2)	2 ( 1.5)	4 ( 2.9)	4 ( 2.5)	5 ( 3.2)	4 ( 2.6)
Irritation eye	3 ( 2.2)	1 ( 0.7)	5 ( 3.7)	6 ( 3.8)	4 ( 2.5)	0 ( 0.0)
Pain eye	1 ( 0.7)	11 ( 8.2)	2 ( 1.5)	4 ( 2.5)	6 ( 3.8)	6 ( 3.8)
Photophobia	2 ( 1.5)	1 ( 0.7)	0 ( 0.0)	5 ( 3.2)	8 ( 5.1)	3 ( 1.9)
Pruritus eye	5 ( 3.7)	6 ( 4.5)	5 ( 3.7)	3 ( 1.9)	7 ( 4.4)	5 ( 3.2)
Stinging eye	5 ( 3.7)	6 ( 4.5)	2 ( 1.5)	5 ( 3.2)	8 ( 5.1)	3 ( 1.9)
Visual disturbance	5 ( 3.7)	6 ( 4.5)	8 ( 5.9)	4 ( 2.5)	9 ( 5.7)	10 ( 6.4)

Note: CsA = cyclosporine ophthalmic emulsion.

The most common ocular adverse event was burning, which was reported by between 14% and 22% of patients in each cyclosporine treatment group compared to between 6% and 9% in the vehicle groups. The majority of ocular adverse events were considered to be treatment-related. In each study, an ocular infection was reported for only 1 patient, who was in the vehicle group in each case. There was thus no indication of local immunosuppression during treatment with cyclosporine ophthalmic emulsion.

The most common systemic adverse events were infection (colds and upper respiratory infections), flu syndrome, headache, sinus infection, hypertension, and bronchitis. There were no clinically relevant differences among treatment groups, and few systemic effects were considered to be treatment-related.

Serious adverse events (SAEs) were reported in study 002 for 5.9% (8/135) of patients in the 0.05% cyclosporine group, 9.0% (12/134) of those in the 0.1% cyclosporine group, and 8.1% (11/136) of those in the vehicle group. The corresponding percentages in study 003 were 5.7%

(9/158), 5.1% (8/158), and 1.9% (3/156). The investigators considered each of the SAEs to have either no relationship to study medication or unlikely to be related to study medication.

Among the SAEs, there were 5 deaths during the studies, which were considered to have either no relationship to study medication or unlikely to be related to study medication. In study 002, 1 patient treated with 0.1% cyclosporine died due to hepatic failure/renal failure/cholestiasis and 1 patient treated with vehicle due to sepsis/respiratory failure/cardiac arrest. In study 003, 1 patient treated with 0.05% cyclosporine died following a sudden cardiac event, 1 patient treated with 0.01% cyclosporine due to cardiac arrest, and another patient treated with 0.1% cyclosporine due to pneumonia/toxic shock.

Adverse events were the reason for discontinuation of the Vehicle-Controlled Masked Treatment Phase in study 002 for 6.7% (9/135) of patients in the 0.05% cyclosporine group, 11.2% (15/134) of those in the 0.1% cyclosporine group, and 4.4% (6/136) of those in the vehicle group. The corresponding percentages in study 003 were 6.3% (10/158), 8.9% (14/158), and 4.5% (7/156).

#### Other Safety Parameters

In each study, there were no clinically significant among-group differences in visual acuity, intraocular pressure, or biomicroscopy.

#### 3.7.3.10 Dose and Regimen Rationale

The 0.05% concentration of cyclosporine ophthalmic emulsion, which has proven benefit, was at least as effective in the Sponsor's clinical studies as the 0.1% concentration, and was safe and well tolerated, is proposed for marketing.

The recommended dosage of cyclosporine ophthalmic emulsion for patients with moderate to severe KCS, with or without Sjögren's syndrome, is topical application to each eye twice daily. Following the direction of previous clinical studies with SANDIMMUNE® ophthalmic ointment, twice-daily treatment was chosen as the dosage regimen. Ocular pharmacokinetic studies in rabbits after a single drop of 0.2% cyclosporine indicate a 26 to 44-hour half-life in most ocular tissues (study report PK-95-010, 1995), suggesting the possibility of once-daily dosing. However, the twice-daily regimen minimizes differences between peak and trough drug



levels and was chosen to provide a more constant drug exposure to ocular tissues over the entire dosing interval. In addition, it is a well-accepted regimen with respect to patient compliance.

#### 3.7.3.11 Discussion

##### Efficacy

Using traditional clinical methods to assess improvement in objective and subjective measures of dry-eye disease, the Phase 3 studies demonstrated the efficacy of 0.05% and 0.1% cyclosporine ophthalmic emulsion. Supporting the approval of cyclosporine emulsion, statistically and clinically significant among-group differences favoring at least one of the cyclosporine concentrations vs vehicle were found for 4 key efficacy parameters: the objective signs of corneal staining and the categorized Schirmer tear test with anesthesia, and the subjective endpoints of blurred vision and REFRESH<sup>®</sup> use. Specifically, the following among-group differences favored cyclosporine emulsion over vehicle:

- Corneal staining in study 002 (ITT analysis at month 6), study 003 (severe subgroup at months 4 and 6), and the ITT meta-analysis (at months 4 and 6)
- Categorized Schirmer with anesthesia in study 002 (ITT analysis approached statistical significance at month 6), study 003 (ITT analysis at month 6), and the ITT meta-analysis (at months 3 and 6)
- Blurred vision in study 002 (ITT analysis at months 3 and 4), study 003 (severe subgroup approached statistical significance at month 6), and the ITT meta-analysis (at months 1, 3, 4, and 6)
- REFRESH<sup>®</sup> use in study 002 (ITT analysis at month 3), study 003 (severe subgroup at month 6), and the ITT meta-analysis (at month 6)

Combining these 4 parameters into a single measure of efficacy, the percentage of responders at month 6 was statistically significantly greater with both the 0.05% and 0.1% cyclosporine emulsion than with vehicle in each of the Phase 3 studies.

Improvement in each of the 4 key efficacy parameters with 0.05% cyclosporine was clinically relevant as well as statistically significant. Decreases in corneal staining indicate improved corneal health with a smoother refractive surface and reduced risk for infection and ocular

discomfort. Corneal staining improved from baseline by approximately 1 grade with 0.05% cyclosporine emulsion in both Phase 3 studies. The improvement in corneal staining can have a beneficial effect on vision. Subjectively, patients experienced decreased blurred vision with 0.05% cyclosporine emulsion. In both studies, blurred vision improved by approximately 0.5 grade after 6 months of treatment with 0.05% cyclosporine emulsion.

Patients had low baseline Schirmer scores with anesthesia (4 to 6 mm/5 minutes) in both studies, indicating moderate to severe dry eyes. These values increased approximately 70% in study 002 and 55% in study 003 after 6 months of treatment with 0.05% cyclosporine emulsion. Such increases in tear production are substantial and clinically important. Another related indicator of disease severity is the frequency of daily artificial tear use. After treatment with 0.05% cyclosporine emulsion for 6 months, REFRESH<sup>®</sup> use decreased significantly, suggesting that patients' eyes felt better and that the need for frequent use was reduced.

In each of the Phase 3 studies, improvement from baseline was generally seen with each concentration of cyclosporine emulsion at each follow-up visit. The major difference between the studies was an enhanced vehicle response in study 003. It appeared that patients in the vehicle group in study 003 had milder disease than those in the cyclosporine emulsion groups. For example, in the ITT population at baseline there was statistically significantly lower REFRESH<sup>®</sup> use as well as statistically significantly less corneal staining with vehicle. Also, there was a lower proportion of patients in the severe disease subgroup in the vehicle treatment group compared to each of the cyclosporine emulsion groups, and a higher goblet cell density in the vehicle group compared to the 0.05% cyclosporine emulsion group. Therefore, improvement may have been more easily demonstrated in patients who received vehicle in study 003. The 3 key efficacy parameters that did not have statistically significant among-group differences in the ITT analysis of study 003 reached or approached statistical significance in the more homogeneous subpopulation of patients with severe disease.

In addition to the ITT population and the subpopulation of patients with severe dry-eye disease, the traditional clinical parameters also showed efficacy in the subgroup of patients with Sjögren's syndrome. The finding that efficacy was not just limited to patients with Sjögren's syndrome, who have frank systemic autoimmune disease, supports the hypothesis that the etiology of KCS is localized immunoreactivity and inflammation of the ocular surface and lacrimal tissues with or without systemic autoimmune disease.

Because KCS is a disease of inflammation and altered immunity, a number of tertiary tests were performed to measure the effects of cyclosporine ophthalmic emulsion on these parameters. In normal eyes there is low expression of the immune activation marker HLA-DR, the inflammation marker CD11a (ICAM-1 receptor), and the inflammatory cytokine IL-6 (Jones et al, 1994; Baudouin et al, 1997). Baseline data in KCS patients with and without Sjögren's syndrome showed the presence of immune activation markers (HLA-DR and HLA-DQ), inflammation markers (CD3, CD4, CD8, and CD11a), and the inflammatory cytokine IL-6 (Tertiary Reports: Baudouin and Baudouin, 1999; Pflugfelder, 1999; Smith et al, 1999).

Tertiary test results following 6 months of treatment with 0.05% cyclosporine emulsion showed a reduction in both inflammation and immune reactivity within the ocular surface in KCS patients with and without Sjögren's syndrome:

- Inflammatory cytokine IL-6 levels in the conjunctival epithelium showed a statistically significant decrease from baseline.
- Using conjunctival biopsies, inflammatory and immune activation markers decreased:
  - The immune activation marker HLA-DR decreased 34% compared to a 160% increase with vehicle. The within and among-group differences were statistically significant.
  - The inflammation marker CD11a decreased 11% compared to a 104% increase with vehicle. The among-group difference was statistically significant.
  - CD3 (total T cells) and CD8 (T suppressor cells) decreased compared to an increase with vehicle.

Improvement of the ocular surface health on a cellular level was measured by the increased density of goblet cells in the conjunctival biopsy samples. Goblet cell density increased 191% in the 0.05% cyclosporine group compared to an increase of only 13% with vehicle. Since goblet cells are thought to be the primary source for the synthesis and secretion of mucin, the innermost layer of the tear film (Tseng, 1986), this increase in density represents a clinically relevant improvement of the ocular surface health.

Cyclosporine ophthalmic emulsion positively influences the underlying mechanisms of dry-eye disease, thus providing therapeutic benefit. These effects were shown in both Phase 3 studies and confirmed in the tertiary test results.

#### Safety

Cyclosporine ophthalmic emulsion administered BID in concentrations from 0.05% to 0.4% for up to 3 months, and 0.05% and 0.1% for up to 6 months, was well tolerated locally and systemically in patients with moderate to severe KCS. Ocular adverse events were not unexpected with an ophthalmic disease and a topical study medication. The most common ocular adverse event was burning, which was more frequent with cyclosporine emulsion than vehicle in the Phase 3 studies. No bacterial or fungal ocular infections were reported in patients treated with cyclosporine ophthalmic emulsion, and overall, there was no sign of harmful local immunosuppression.

There were no clinically significant differences among cyclosporine emulsion and vehicle-treated patients in visual acuity, intraocular pressure, or biomicroscopy throughout the Phase 2 and Phase 3 studies.

Ocular microbial analyses of conjunctival bacterial isolates were performed in the Phase 2 study to address concerns that daily use of a topical ophthalmic immunosuppressive agent could predispose patients to ocular infections. In fact, cyclosporine emulsion treatment was associated with a decrease from baseline in the presence of abnormal organisms. Similar significant reductions of pathogenic organisms have been seen in dry-eye patients after punctal occlusion, suggesting that adequate tear production plays a role in the maintenance of normal ocular flora (Castillo et al, 1994). Thus cyclosporine emulsion may improve the ocular microbiology of KCS patients through its beneficial effects on the underlying dry-eye condition.

Clinically important adverse events that have been associated with oral cyclosporine include nephrotoxicity, hepatotoxicity, neurotoxicity, and malignant lymphomas. Such treatment-related toxicities were neither expected nor seen with the topical usage of the cyclosporine emulsion. There were no notable differences between the vehicle and cyclosporine emulsion groups in any blood chemistry or hematology findings, including renal and hepatic function tests.

Systemic treatment of rheumatoid arthritis and psoriasis patients with oral cyclosporine (2.5 to 5 mg/kg/day) produced blood concentrations (mean  $\pm$  standard deviation) that ranged

from a trough of  $74.9 \pm 46.7$  ng/mL to a  $C_{\max}$  of  $655 \pm 186$  to  $728 \pm 263$  ng/mL (PDR - NEORAL<sup>®</sup>, 1998). In contrast, topical cyclosporine emulsion (1 to 2  $\mu\text{g}/\text{kg}/\text{day}$ ) produced mean blood trough cyclosporin A concentrations and  $C_{\max}$  values of less than 0.1 ng/mL (study reports PK-96-018, 1996; PK-98-109, 1998; PK-98-112, 1998). These concentrations are at least 749 to 6,550 times lower than the trough and  $C_{\max}$  values seen with systemic therapeutic use. In 98.2% (544/554) of the analyzed samples, blood concentrations following topical ophthalmic administration of cyclosporine were below the assay's quantitation limit of 0.1 ng/mL. All 10 quantifiable samples were from patients receiving 0.1% cyclosporine emulsion; in no patient was the blood cyclosporin A concentration greater than 0.299 ng/mL. Comparison of trough blood cyclosporin A concentrations during multiple ocular dosing indicated no detectable accumulation.

#### 3.7.3.12 Conclusions

In summary, 0.05% cyclosporine emulsion is proposed for approval for the treatment of moderate to severe KCS, because it has proven benefits, is at least as effective as 0.1% cyclosporine emulsion, and is safe and well tolerated.

- Clinically and statistically significant effects in favor of both concentrations of cyclosporine emulsion in a number of important parameters in the ITT population in each of the Phase 3 studies, as well as in a confirmatory meta-analysis of the ITT population. Notably, the cyclosporine formulations achieved clinically and statistically significant results versus vehicle for the individual parameters corneal staining, blurred vision, categorized Schirmer with anesthesia, and reduction in REFRESH<sup>®</sup> use, as well as in the responder analysis using all 4 parameters. In addition, improvement with the cyclosporine formulations was seen in virtually all efficacy parameters in the within-group analyses.
- Efficacy data for the traditional dry-eye study parameters in the ITT population are supported by results of the tertiary tests that showed reductions with 0.05% cyclosporine emulsion in the inflammation and immune reactivity underlying KCS. Notably, IL-6, CD11a, and HLA-DR were reduced. In addition, goblet cell density in conjunctival biopsies was elevated by the 0.05% cyclosporine emulsion.

- Analysis of a number of subpopulations from the clinical program supports the efficacy seen in the ITT population.
- Although the vehicle delivered a significant beneficial effect to patients, as expected with a formulation designed for the dry-eye population, all statistically significant results in the ITT among-group analyses favored cyclosporine over vehicle. This finding is particularly important when it is recalled that the use of REFRESH® tears was permitted as needed during the clinical studies.
- Cyclosporine ophthalmic emulsion administered BID in concentrations from 0.05% to 0.4% for up to 3 months, and 0.05% and 0.1% for up to 6 months, was well tolerated locally without significant systemic effects in patients with moderate to severe KCS, with or without Sjögren's syndrome. Topical cyclosporine ophthalmic emulsion produced minimal systemic exposure, which correlated with the lack of local and systemic toxicity found in these studies.

### 3.7.3.13 References

#### Study Report References

STUDY NUMBER	STUDY TITLE	VOLUME PAGE
192371-001	A dose-ranging study evaluating the safety, tolerability, and efficacy of cyclosporine (0.05, 0.1, 0.2, 0.4%) and vehicle ophthalmic emulsions in the treatment of moderate to severe keratoconjunctivitis sicca. Allergan, 1997.	vol. 27 p. 002
192371-002	A multicenter, double-masked, randomized, vehicle-controlled, parallel-group study of the safety and efficacy of cyclosporine 0.05% and 0.1% ophthalmic emulsions used twice daily for up to one year in patients with moderate to severe keratoconjunctivitis sicca. Allergan, 1999.	vol. 40 p. 001
192371-003	A multicenter, double-masked, randomized, vehicle-controlled, parallel-group study of the safety and efficacy of cyclosporine 0.05% and 0.1% ophthalmic emulsions used twice daily for up to one year in patients with moderate to severe keratoconjunctivitis sicca. Allergan, 1999.	vol. 60 p. 001
PK-95-010	Ocular pharmacokinetics of cyclosporine after a single eye-drop instillation of 0.2% <sup>3</sup> H-cyclosporine ophthalmic emulsion into albino rabbit eyes. Allergan, 1995.	vol. 18 p. 257

STUDY NUMBER	STUDY TITLE	VOLUME PAGE
PK-96-018	Pharmacokinetic analysis of cyclosporin A in human blood for clinical study entitled "A dose-ranging study evaluating the safety, tolerability, and efficacy of cyclosporine (0.05, 0.1, 0.2, 0.4%) and vehicle ophthalmic emulsions in the treatment of moderate to severe keratoconjunctivitis sicca". Allergan, 1996.	vol. 19 p. 284
PK-98-109	Six month interim pharmacokinetic analysis of plasma concentrations for study 192371-002 titled, "A multicenter, double-masked, randomized, vehicle-controlled, parallel-group study of the safety and efficacy of cyclosporine 0.05% and 0.1% ophthalmic emulsions used twice daily for up to one year in patients with moderate to severe keratoconjunctivitis sicca". Allergan, 1998.	vol. 19 p. 357
PK-98-112	Interim report of blood cyclosporin A concentrations during one dosing interval for study 192371-002 titled, "A multicenter, double-masked, randomized, vehicle-controlled, parallel-group study of the safety and efficacy of cyclosporine 0.05% and 0.1% ophthalmic emulsions used twice daily for up to one year in patients with moderate to severe keratoconjunctivitis sicca". Allergan, 1998.	vol. 19 p. 371
Tertiary Report: Conjunctival Biopsies (NEI)	Investigator Summary Report of Baseline Data for Conjunctival Biopsies (Protocol NEI 98-E1-0032). JA Smith (NEI), SM Whitcup (NEI), and ME Stern (Allergan), 1999.	vol. 85 p. 001



STUDY NUMBER	STUDY TITLE	VOLUME PAGE
Tertiary Report: Flow Cytometry	Investigator Summary Report of Baseline Data for Flow Cytometry (Protocol 192371-501). C Baudouin and F Baudouin (Ambroise Paré Hospital), 1999.	vol. 85 p. 008
Tertiary Report: IL-6	Investigator Summary Report of Tertiary Tests of Inflammatory Cytokine Interleukin-6 (Protocol 192371-003). S Pflugfelder (University of Miami), 1999.	vol. 85 p. 016
Tertiary Report: Conjunctival Biopsies	Investigator Summary Report of Tertiary Tests of Conjunctival Biopsies (Protocols 192371-002 and 192371-003). IK Gipson (Schepens Eye Research Institute), 1999.	vol. 85 p. 029

Literature References

Baudouin C, Brignole F, Becquet F, et al. Flow cytometry in impression cytology specimens. A new method for evaluation of conjunctival inflammation. Invest Ophthalmol Vis Sci 1997;38:1458-1464. [vol. 86 p. 020]

Castillo NM, Kosrirukvongs P, Gritz DC, et al. Quantitative ocular microbial flora of dry eye patients pre and post punctal occlusion [abstract]. Invest Ophthalmol Vis Sci 1994;35:1691. [vol. 86 p. 220]

Gilbard JP. Tear film osmolarity and keratoconjunctivitis sicca. In: Holly FJ, ed. The Preocular Tear Film in Health, Disease, and Contact Lens Wear. Lubbock, TX: Dry Eye Institute, Inc, 1986:127-139. [vol. 86 p. 321]

Jones DT, Monroy D, Zhonghua J, et al. Sjögren's syndrome: cytokine and Epstein-Barr viral gene expression within the conjunctival epithelium. Invest Ophthalmol Vis Sci 1994;35:3493-3504. [vol. 87 p. 115]

PDR (Physicians' Desk Reference). Product information for methotrexate. Montvale, NJ: Medical Economics Company, Inc; 1998:1281-1285. [vol. 88 p. 084]

PDR (Physicians' Desk Reference). Product information for NEORAL<sup>®</sup> (cyclosporine). Montvale, NJ: Medical Economics Company, Inc; 1998:1882-1889. [vol. 88 p. 103]

Pflugfelder SC, Tseng SC, Yoshino K, et al. Correlation of goblet cell density and mucosal epithelial membrane mucin expression with rose bengal staining in patients with ocular irritation. *Ophthalmology* 1997;104(2):223-235. [vol. 88 p. 175]

Ralph RA. Conjunctival goblet cell density in normal subjects and in dry eye syndromes. *Invest Ophthalmol Vis Sci* 1975;14:299-302. [vol. 88 p. 229]

Tseng SCG. Modulation of conjunctival goblet cell differentiation by vitamin A: A possible mechanism for mucin deficiency. In: Holly FJ, ed. *The preocular tear film in health, disease, and contact lens wear*. Lubbock TX: Dry Eye Institute, Inc, 1986:876-893. [available upon request]

#### 3.7.4 OTHER STUDIES AND INFORMATION

The Sponsor has 4 clinical studies that are ongoing with cyclosporine ophthalmic emulsion in patients with KCS; 2 of these studies are controlled and 2 are open-label. No efficacy or safety data from these studies are included in this submission. Brief descriptions of the studies follow.

Study NEI 98-EI-0032 is a single-center, double-masked, randomized, vehicle-controlled, parallel-group pilot study of 0.1% cyclosporine ophthalmic emulsion used 4 times daily for 2 months in patients with moderate to severe KCS. The study began in December 1997; enrollment of 30 patients is planned. Observations from baseline conjunctival biopsies are discussed in NDA Section 8.6, Integrated Summary of Efficacy.

Study 192371-501 is a multicenter, double-masked, randomized, vehicle-controlled, parallel-group study of 0.05% and 0.1% cyclosporine ophthalmic emulsions used twice daily for up to 1 year in patients with moderate to severe KCS. The study began in September 1997; enrollment of 420 patients is planned. This study, conducted in Europe, follows an identical protocol for safety and efficacy evaluations as the Phase 3 trials conducted in the United States (192371-002 and 192371-003). Observations from baseline flow cytometry are discussed in NDA Section 8.6, Integrated Summary of Efficacy.

Study 192371-004 is a multicenter, open-label extension of the Phase 2 study 192371-001 to evaluate the safety of 0.1% cyclosporine ophthalmic emulsion used twice daily for up to 1 year in patients with moderate to severe KCS. The study began in January 1998; enrollment can include a maximum of the 150 patients who completed the original study.

Study 192371-005 is a multicenter, open-label extension of the Phase 3 studies 192371-002 and 192371-003 to evaluate the safety of 0.1% cyclosporine ophthalmic emulsion used twice daily for 1 additional year in patients with moderate to severe KCS previously dosed for 6 to 12 months with 0.05% or 0.1% cyclosporine. The study began in July 1998; enrollment can include a maximum of 877 patients enrolled in the original studies.

### 3.7.5 SAFETY SUMMARY – GENERAL SAFETY CONCLUSIONS

The primary sources of safety data for this submission are the Phase 3 studies, 192371-002 and 192371-003 (hereafter referred to as 002 and 003, respectively; study reports 192371-002, 1999 and 192371-003, 1999). These studies were both multicenter, double-masked, randomized, vehicle-controlled, parallel-group studies of the safety and efficacy of 0.05% and 0.1% cyclosporine ophthalmic emulsions used twice daily (BID) in patients with moderate to severe keratoconjunctivitis sicca (KCS) with or without Sjögren's syndrome. Because these studies had the same design, their safety data were pooled. The safety data reported here are from the initial 6-month Vehicle-Controlled Masked Treatment Phase. Following completion of the ongoing 6-month Cyclosporine Treatment Extension Phase, additional data will be submitted to provide further support for long-term usage. Safety data are presented separately from the Phase 2 dose-response study, 192371-001 (study report 192371-001, 1997). This study evaluated 0.05%, 0.1%, 0.2%, and 0.4% cyclosporine and vehicle ophthalmic emulsions instilled BID for 3 months.

#### 3.7.5.1 Extent of Exposure

Overall, the Phase 2 and Phase 3 studies provided a safety database of 1039 patients with KCS, including 714 patients who were exposed to any concentration of cyclosporine ophthalmic emulsion. In the Phase 3 studies, 293 patients received 0.05% cyclosporine emulsion, 292 patients received 0.1% cyclosporine emulsion, and 292 patients received vehicle. Note that one drop in each eye BID of 0.05% cyclosporine emulsion delivers approximately 0.057 mg of cyclosporine per day, given a drop size of approximately 28.5  $\mu$ L, or less than 1  $\mu$ g/kg/day for a 60 kg patient. The median duration of treatment exposure at the end of the Vehicle-Controlled Masked Treatment Phase was 180 days (NDA Section 8.7.16, Table 1), with a range from 1 to 352 days. Approximately 77% of patients in each treatment group completed the 6-month Vehicle-Controlled Masked Treatment Phase (NDA Section 8.7.16, Table 3).

Systemic exposure was minimal. Blood samples from subsets of patients in the Phase 3 study 002 were assayed using liquid chromatography/mass spectroscopy-mass spectroscopy (LC/MS-MS) with a quantitation limit of 0.1 ng/mL in human blood (study reports PK-98-109, 1998; PK-98-112, 1998). During the Vehicle-Controlled Masked Treatment Phase, trough blood concentrations of cyclosporin A were below the limit of quantitation (BLQ) at all visits for all

patients in the 0.05% cyclosporine emulsion group (113 samples). Trough blood concentrations of cyclosporin A were quantifiable in only 6 of 70 samples at months 1 or 6 from patients in the 0.1% cyclosporine emulsion group. The highest concentration reported was 0.299 ng/mL. Comparison of the trough blood concentrations after 1 and 6 months of treatment indicated no detectable accumulation during multiple ocular dosing.

During the Cyclosporine Treatment Extension Phase of study 002, blood samples were collected at 1, 2, 3, 4, 6, 8, 10, and 12 hours after the morning dose following 9 to 12 months of treatment. Blood concentrations of cyclosporin A were BLQ at all timepoints for all patients receiving 0.05% cyclosporine emulsion (64 samples). Blood concentrations of cyclosporin A were quantifiable in only 3 of 144 samples from patients receiving 0.1% cyclosporine emulsion. The highest concentration reported was 0.105 ng/mL.

In the Phase 2 study, 31 patients received 0.05% cyclosporine emulsion, 32 patients received 0.1% cyclosporine emulsion, 34 patients received 0.2% cyclosporine emulsion, 32 patients received 0.4% cyclosporine emulsion, and 33 patients received vehicle. Approximately 90% of patients in each treatment group completed the 3-month study period (NDA Section 8.11.1, Attachment 9.1, Table 1).

Blood samples were collected from approximately 30 patients in each treatment group in the Phase 2 study (study report PK-96-018, 1996). Trough blood concentrations of cyclosporin A were quantifiable in only 5 of 369 samples. The highest trough concentration reported was 0.157 ng/mL in a patient receiving 0.4% cyclosporine emulsion. Comparison of the trough blood concentrations after 1, 4, and 12 weeks of treatment indicated no detectable accumulation during multiple ocular dosing.

Blood samples also were collected from an additional 3 to 5 patients in each treatment group at 1, 2, and 4 hours after the last dose of the 3-month treatment period. The maximum blood concentrations ( $C_{max}$ ) of cyclosporin A were less than 0.1 ng/mL in all samples for patients receiving 0.05% and 0.1% cyclosporine emulsion. The highest  $C_{max}$  reported was 0.158 ng/mL in a patient receiving 0.4% cyclosporine emulsion.

### 3.7.5.2 Demographics and Other Patient Characteristics

The Phase 3 studies enrolled 877 patients with moderate to severe KCS with or without Sjögren's syndrome. Age ranged from 21.6 to 90.3 years with a mean  $\pm$  standard deviation (SD) of  $59.6 \pm 13.9$  years (NDA Section 8.7.16, Table 4). The study population was primarily Caucasian (84.4%, 740/877), and there were more women (81.5%, 715/877) than men (18.5%, 162/877). This is consistent with the preponderance of dry-eye disease reported by postmenopausal women (McCarty et al, 1998).

Criteria for the classification of Sjögren's syndrome included ocular symptoms, oral symptoms, ocular signs, and systemic autoantibodies (Vitali et al, 1993). Overall, 30.8% (270/877) of patients in the Phase 3 studies were classified as having Sjögren's syndrome (NDA Section 8.7.16, Table 5). This represents 37.6% (270/718) of the patients who had autoantibody tests; such tests were not performed for 159 patients.

The most frequently cited disorders in patients' medical histories were musculoskeletal (48.5%, 425/877), gynecological (48.4%, 346/715 females), and cardiovascular conditions (38.0%, 333/877; NDA Section 8.7.16, Table 6). Patients' ophthalmic histories included eye surgery/trauma (17.4%, 153/877), corneal disease other than KCS (8.8%, 77/877), and vitreal or retinal disease (8.1%, 71/877; NDA Section 8.7.16, Table 7).

The Phase 2 study enrolled 162 patients with moderate to severe KCS. Age ranged from 31 to 88 years with a mean  $\pm$  SD of  $58.6 \pm 12.0$  years (NDA Section 8.11.1, Attachment 9.1, Table 7). There were more women (84%, 136/162) than men (16%, 26/162) and the study population was primarily Caucasian (90%, 145/162). Medical history included surgery (75%, 121/162), allergies (54%, 88/162), and general systemic conditions (22%, 35/162; NDA Section 8.11.1, Attachment 9.1, Table 10). Ophthalmic history included eye surgery (15%, 24/162), corneal disease other than KCS (6%, 9/162), and glaucoma (4%, 6/162).

### 3.7.5.3 Adverse Events

#### Adverse Events Regardless of Causality

During the Vehicle-Controlled Masked Treatment Phase of the Phase 3 studies, 56.7% (166/293) of the patients treated with 0.05% cyclosporine emulsion, 63.0% (184/292) of those treated with 0.1% cyclosporine emulsion, and 57.9% (169/292) of those treated with vehicle experienced one

or more adverse events, regardless of causality (NDA Section 8.7.16, Tables 9-12). The numbers of patients with adverse events by relationship to study medication and severity are summarized in Table 3.7.5.3-1.

**Table 3.7.5.3-1 Number (%) of Patients in the Phase 3 Studies with Adverse Events by Relationship to Study Medication and Severity**

Category	0.05% Cyclosporine N=293	0.1% Cyclosporine N=292	Vehicle N=292
Overall	166 (56.7)	184 (63.0)	169 (57.9)
Relationship:			
None	51 (17.4)	51 (17.5)	56 (19.2)
Unlikely	41 (14.0)	48 (16.4)	56 (19.2)
Possible	42 (14.3)	38 (13.0)	36 (12.3)
Probable	24 ( 8.2)	35 (12.0)	13 ( 4.5)
Definite	8 ( 2.7)	12 ( 4.1)	8 ( 2.7)
Severity:			
Mild	66 (22.5)	62 (21.2)	63 (21.6)
Moderate	73 (24.9)	88 (30.1)	83 (28.4)
Severe	26 ( 8.9)	32 (11.0)	23 ( 7.9)
Not available	1 ( 0.3)	2 ( 0.7)	0 ( 0.0)

The types of adverse events and incidences were generally similar among the 3 treatment groups. The body systems most commonly affected were special senses, which includes ocular adverse events (35.8%), body as a whole (19.3%), and respiratory (11.4%, NDA Section 8.7.16, Table 11). Adverse events in each of the other body systems were reported by fewer than 9% of patients in any treatment group.

Events reported by at least 3% of patients (9 patients) in either of the cyclosporine emulsion groups are listed by body system in Table 3.7.5.3-2.

**Table 3.7.5.3-2 Number (%) of Patients in the Phase 3 Studies with Adverse Events Reported by  $\geq$  3% of Patients in Either Cyclosporine Group, Regardless of Causality**

<b>COSTART body system/ Preferred term</b>	<b>0.05% Cyclosporine N=293</b>	<b>0.1% Cyclosporine N=292</b>	<b>Vehicle N=292</b>
<b>Body as a whole</b>			
Infection	18 ( 6.1)	23 ( 7.9)	29 ( 9.9)
Flu syndrome	13 ( 4.4)	6 ( 2.1)	13 ( 4.5)
Headache	11 ( 3.8)	11 ( 3.8)	7 ( 2.4)
<b>Cardiovascular</b>			
Hypertension	10 ( 3.4)	4 ( 1.4)	7 ( 2.4)
<b>Respiratory</b>			
Infection sinus	9 ( 3.1)	7 ( 2.4)	13 ( 4.5)
<b>Special senses</b>			
Burning eye	47 (16.0)	51 (17.5)	21 ( 7.2)
Discharge eye	14 ( 4.8)	7 ( 2.4)	8 ( 2.7)
Foreign body sensation	11 ( 3.8)	7 ( 2.4)	8 ( 2.7)
Conjunctival hyperemia	11 ( 3.8)	12 ( 4.1)	2 ( 0.7)
Stinging eye	10 ( 3.4)	14 ( 4.8)	5 ( 1.7)
Irritation eye	9 ( 3.1)	5 ( 1.7)	5 ( 1.7)
Visual disturbance	9 ( 3.1)	15 ( 5.1)	18 ( 6.2)
Pruritus eye	8 ( 2.7)	13 ( 4.5)	10 ( 3.4)
Photophobia	7 ( 2.4)	9 ( 3.1)	3 ( 1.0)
Eye pain	5 ( 1.7)	17 ( 5.8)	8 ( 2.7)

Systemic infections (primarily colds and upper respiratory infections), flu syndrome, headache, hypertension, and sinus infection were reported at similar or higher rates in the vehicle group than in the cyclosporine emulsion groups. In all treatment groups, isolated abnormal laboratory test results were reported as adverse events; however, none was thought to be related to the study medication.



Ocular burning was reported more frequently in the 0.05% and 0.1% cyclosporine emulsion groups (by 16.0% and 17.5% of patients, respectively) than in the vehicle group (7.2%).

Conjunctival hyperemia and stinging eye showed a similar pattern but were reported by fewer patients overall than ocular burning. Other ocular adverse events showed no notable differences among the treatment groups.

Ocular infections were reported for 2 patients in the Phase 3 studies, both of whom were in the vehicle treatment group. There was no indication of harmful local immunosuppression during treatment with cyclosporine ophthalmic emulsion.

Nephrotoxicity and hepatotoxicity were not seen in these studies. Liver cirrhosis was reported for 1 patient in the 0.05% cyclosporine emulsion group, but was considered unlikely to be related to the study medication as the patient had a long history of abnormal liver function.

Three patients were diagnosed with a lymphoma, each considered unlikely to be related to study medication. Two patients had received 0.1% cyclosporine emulsion for approximately 5 weeks and 1 patient had received 0.1% cyclosporine emulsion for approximately 12 weeks. One patient had a history of Sjögren's syndrome; the other 2 patients had received long-term treatment of rheumatoid arthritis with methotrexate. Both factors are associated with an increased risk of lymphoma.

Seven other cancers were reported during the Phase 3 studies, none of which was considered to be related to the study medication. In the 0.05% cyclosporine emulsion group, 1 patient was diagnosed with skin cancer on the face and another with squamous cell cancer of the esophagus. In the 0.1% cyclosporine emulsion group, 1 patient was diagnosed with a right frontal glioblastoma brain tumor, and 2 patients were diagnosed with basal cell carcinomas of the skin. In the vehicle group, 1 patient was diagnosed with a basal cell carcinoma of the right upper cheek and another was diagnosed with breast cancer.

In the Phase 2 study, cyclosporine emulsion in concentrations of 0.05%, 0.1%, 0.2%, and 0.4%, 1 drop instilled to each eye BID for 12 weeks, was found to be safe and well tolerated. The incidence of patients with any adverse event regardless of causality, any ocular adverse event, or any severe adverse event was greater in the vehicle group than in any of the cyclosporine emulsion groups (NDA Section 8.11.1, Attachment 9.1, Tables 49 and 50). There was no

apparent relationship between the incidence of adverse events regardless of causality and the dose of the cyclosporine emulsion (Table 3.7.5.3-3).

**Table 3.7.5.3-3 Number (%) of Patients in Phase 2 Study with Adverse Events, Regardless of Causality**

Adverse events Regardless of causality	Cyclosporine				Vehicle N=33
	0.05% N=31	0.1% N=32	0.2% N=34	0.4% N=32	
Any adverse event	3 ( 9.7)	4 (12.5)	6 (17.6)	7 (21.9)	10 (30.3)
Any severe adverse event	0 ( 0.0)	0 ( 0.0)	1 ( 2.9)	2 ( 6.3)	5 (15.2)
Any ocular adverse event	2 ( 6.5)	2 ( 6.3)	2 ( 5.9)	4 (12.5)	6 (18.2)
Any systemic adverse event	1 ( 3.2)	4 (12.5)	5 (14.7)	4 (12.5)	5 (15.2)

The most frequently encountered ocular adverse events regardless of causality were burning and superficial punctate keratitis, with 5 reports each. These events were distributed among all treatment groups. No ocular infections occurred during the treatment or post-treatment periods. Systemic events likewise were distributed among all treatment groups. No single systemic event was reported for more than 1 patient per treatment group.

#### Serious Adverse Events

In the Phase 3 studies, serious adverse events (SAEs) were reported for 5.8% (51/877) of patients: 5.8% (17/293) of patients in the 0.05% cyclosporine emulsion group, 6.8% (20/292) of those in the 0.1% cyclosporine emulsion group, and 4.8% (14/292) of those in the vehicle group (NDA Section 8.7.16, Tables 17 and 18). The investigators considered each of the SAEs to have either no relationship to study medication or unlikely to be related to study medication.

Among the SAEs, there were 5 deaths during the Phase 3 studies (NDA Sections 8.11.2 and 8.11.3, Attachment 13.3). In the 0.05% cyclosporine emulsion group, 1 patient died following a sudden cardiac event. In the 0.1% cyclosporine emulsion group, 1 patient died due to a cardiac arrest, 1 following hospitalization with lobar pneumonia and probable toxic shock syndrome, and 1 due to hepatic failure with acute renal failure and cholestiasis. In the vehicle group, 1 patient died following an episode of sepsis, respiratory failure, and cardiac arrest. In addition, 1 patient

who withdrew from the study prematurely, due to lymphoma as previously noted, died approximately 3 months after termination.

There were no deaths during the Phase 2 study. Two patients experienced SAEs, neither of which was considered to be related to treatment (NDA Section 8.11.1, Attachment 9.1, Table 57). One vehicle patient experienced severe depression, and 1 patient receiving 0.4% cyclosporine emulsion had an acute anterior myocardial infarction (MI).

#### Discontinuations Due to Adverse Events

In the Phase 3 studies, adverse events were the reason for discontinuation from the Vehicle-Controlled Masked Treatment Phase for 6.5% (19/293) of patients in the 0.05% cyclosporine emulsion group, 9.9% (29/292) of those in the 0.1% cyclosporine emulsion group, and 4.5% (13/292) of those in the vehicle group (NDA Section 8.7.16, Table 3). Among the patients who discontinued due to adverse events, ocular events were reported for 68% (13/19) of those in the 0.05% cyclosporine emulsion group, 79% (23/29) of those in the 0.1% cyclosporine emulsion group, and 62% (8/13) of those in the vehicle group (NDA Sections 8.11.2 and 8.11.3, Attachment 13.1, Table 3).

In the Phase 2 study, 4 patients discontinued due to adverse events: 1 patient receiving 0.2% cyclosporine emulsion (burning and hyperemia), 1 patient receiving 0.4% cyclosporine emulsion (MI), and 2 vehicle-treated patients (visual disturbance and burning; conjunctivitis and contact dermatitis) (NDA Section 8.11.1, Attachment 9.1, Table 2).

#### Adverse Events by Subgroup

For the Phase 3 studies, adverse events were examined for the following subgroups: age (< 40 years, 40 to 64 years, and > 64 years), sex, race (Caucasian including Hispanic and non-Caucasian), diagnosis (Sjögren's syndrome and non-Sjögren's), and iris color (dark and light). Although some differences among some of the subgroups were noted, there were no apparent patterns by treatment group (NDA Section 8.7.16, Tables 23 to 33). Overall, adverse events were reported for a higher proportion of females (60.8%, 435/715) than males (51.9%, 84/162), and a higher proportion of patients with Sjögren's syndrome (66.7%, 180/270) than non-Sjögren's patients (55.8%, 339/607).

#### 3.7.5.4 Laboratory Data

In the Phase 2 study, no significant changes from baseline were observed in any blood chemistry or hematology parameters, and the ocular microbiology findings were not remarkable. There were no ocular infections in the cyclosporine-treated patients. Therefore, the Sponsor and the Food and Drug Administration (FDA) concurred at an end of Phase 2 meeting that these endpoints did not need to be included in the Phase 3 program.

##### Blood Chemistry and Hematology

Blood chemistry and hematology were evaluated in the Phase 2 study at baseline (week 0), during treatment (week 4), and at the end of treatment (week 12). The majority of patients in the cyclosporine emulsion and vehicle groups had normal values at all visits. Changes from baseline occurred in only small numbers of patients, were in both directions, and were considered to be neither clinically significant nor related to study medication (NDA Section 8.11.1, Attachment 9.1, Table 79). Differences among the treatment groups were generally not statistically significant (NDA Section 8.11.1, Appendix 10.9.2 K and L). No patients experienced laboratory adverse events related to blood chemistry or hematology parameters.

##### Ocular Microbiology

The conjunctivas from the lower lids of a subset of patients in the Phase 2 study were cultured at baseline (week 0), end of treatment (week 12), and 4 weeks post-treatment (week 16). The most frequently cultured organisms were *Staphylococcus epidermidis*, *Staphylococcus aureus*, and *Enterococcus faecalis* (NDA Section 8.11.1, Attachment 9.1, Tables 63 and 64; and Appendix 10.9.2 M, Tables 5 and 6).

In the cyclosporine emulsion groups, there was a trend toward fewer bacterial species and fewer total strains of organisms at the end of treatment and post-treatment compared to baseline (Table 3.7.5.4). Conversely, in the vehicle group, there was a trend toward an increased number of organisms at week 12, with a return to baseline levels post-treatment at week 16.

**Table 3.7.5.4 Number (%) of Patients in Phase 2 Study with Organisms Isolated**

Parameter	Cyclosporine all concentrations N=48			Vehicle N=11		
	Week 0	Week 12 <sup>a</sup>	Post <sup>b</sup>	Week 0	Week 12	Post <sup>b</sup>
No. Culture-Positive Patients	22 (46)	24 (51)	25 (52)	6 (55)	9 (82)	7 (64)
Total No. Bacterial Species	19	10	15	4	11	4
Total No. Microorganisms	40	31	31	7	19	10

a N = 47 at Week 12

b Post = Post-treatment Week 16

Although there were variations in the microbial flora over the course of the study, these were comparable among the treatment groups (NDA Section 8.11.1, Attachment 9.1, Table 65 and Appendix 10.9.2 M, Table 4). There were no ocular infections in the cyclosporine emulsion groups, and there did not appear to be an overgrowth of ocular microorganisms.

### 3.7.5.5 Other Safety Assessments

#### Visual Acuity

In the Phase 3 studies, approximately one-half of the patients in each treatment group showed no change in the best-corrected visual acuity (VA) at any follow-up visit (NDA Section 8.7.16, Tables 19 and 20). An improvement from baseline VA was seen at month 6 for approximately 30% of eyes in each treatment group; approximately 20% of eyes had worsened. These changes were generally small ( $\leq 2$  lines) and not clinically relevant.

In the Phase 2 study, generally one-half of the patients in each treatment group showed no change from baseline VA (NDA Section 8.11.1, Attachment 9.1, Table 77). Of the remainder, there were similar numbers of increases and decreases in all treatment groups. These changes were generally small ( $\leq 2$  lines) and not remarkable (NDA Section 8.11.1, Attachment 9.1, Table 78).

### Intraocular Pressure

In the Phase 3 studies, intraocular pressure (IOP) was measured in millimeters of mercury (mm Hg) using Goldmann applanation tonometry and averaged over both eyes. There were statistically significant ( $P \leq 0.042$ ) increases in IOP from baseline to month 6 with cyclosporine emulsion (NDA Section 8.7.16, Table 21). However, the mean increases were less than 1 mm Hg and not clinically relevant. The among-group differences were not statistically significant at either baseline or month 6.

In the Phase 2 study, there likewise were no statistically significant differences among the cyclosporine emulsion and vehicle groups in the change from baseline IOP (NDA Section 8.11.1, Attachment 9.1, Tables 71 and 72).

### Biomicroscopy

In the Phase 3 studies, biomicroscopy examination included evaluations of lid and lid margin erythema and swelling, conjunctiva erythema/hyperemia and chemosis, tear film debris, cornea endothelial condition, anterior chamber cells, and flare. Changes in biomicroscopic findings from baseline were similar across the 3 treatment groups (NDA Section 8.7.16, Tables 22.1 - 22.8). The majority of the patients in each treatment group showed no change in any parameter at any follow-up visit. Increases (worsening)  $\geq 2$  grades in any parameter were reported for  $\leq 3.3\%$  of eyes at month 6.

In the Phase 2 study, there were no statistically significant differences among the treatment groups at any visit for lid erythema, lid edema, conjunctival erythema/hyperemia, conjunctival edema, or corneal endothelial condition (NDA Section 8.11.1, Attachment 9.1, Tables 66 - 70). No clinically or statistically significant changes from baseline were seen in any of the 4 cyclosporine emulsion groups.

#### 3.7.5.6 Drug-Drug Interactions

No formal drug interaction studies with cyclosporine ophthalmic emulsion were conducted. Systemic exposure in humans from topical cyclosporine emulsion is minimal, and thus no significant interactions with systemic drugs are expected. There is no information regarding potential interactions of topical ophthalmic drugs coadministered with cyclosporine emulsion as such drugs were prohibited during the Phase 2 and Phase 3 studies.

### 3.7.5.7 Drug Abuse and Overdosage

There is no experience with overdosage in humans using topical cyclosporine ophthalmic emulsion. Excessive topical use of cyclosporine ophthalmic emulsion would not be expected to contribute to any ocular toxicity. Due to low systemic concentrations of cyclosporine after topical treatment with the ophthalmic emulsion, the likelihood of systemic intoxication from topical overdose is remote.

A single unit-dose vial of 0.05% cyclosporine ophthalmic emulsion contains 0.2 mg of cyclosporine. The recommended weight-normalized starting dose of systemically administered cyclosporine for rheumatoid arthritis and psoriasis is 2.5 mg/kg/day (PDR-NEORAL<sup>®</sup>, 1998). Therefore, the dose ingested by a child weighing 14 kg drinking the contents of an entire vial would be 175 times lower than the recommended starting dose of NEORAL<sup>®</sup>.

### 3.7.5.8 Safety Information from Other Sources

#### Previous Studies of Other Formulations of Topical Ophthalmic Cyclosporine in Keratoconjunctivitis Sicca

One unpublished and 5 published studies not conducted by the Sponsor reported on the use of non-emulsion formulations of topical ophthalmic cyclosporine in patients with KCS (study report K201, 1994; Foulks et al, 1996 [study report K206, 1994]; Gündüz and Özdemir, 1994; Helms et al, 1996 [study report K203, 1995]; Laibovitz et al, 1993; Power et al, 1993). Four of these studies used SANDIMMUNE<sup>®</sup> ophthalmic ointment (a corn-oil based formulation) with cyclosporine concentrations ranging from 0.5% to 2.0%. The 2 other studies used 2% cyclosporine in olive oil. These 6 studies enrolled 364 patients with KCS. The most frequently reported adverse events were burning and discomfort; there were no serious adverse events. Blood cyclosporine concentrations, where measured, were below the quantitation limit in all patients.

#### Previous Studies of Other Formulations of Topical Ophthalmic Cyclosporine in Other Indications

Literature published since 1985 includes the following reports on topical cyclosporine use in indications other than KCS: vernal keratoconjunctivitis (BenEzra et al, 1988; Bleik and Tabbara, 1991; Secchi et al, 1990 and 1997); corneal transplants (Belin et al, 1989; Goichot-Bonnat and Pouliquen, 1988; Hoffmann and Wiederholt, 1985; Zhao and Jin, 1995); corneal ulcers (Kervick

et al, 1992; Wiebking and Mehlfeld, 1986; Zhao and Jin, 1993; Zierhut et al, 1989); herpetic stromal keratitis (Gündüz and Özdemir, 1997); necrotizing scleritis (Hoffmann and Wiederholt, 1985/1986); multiple indications (Gündüz and Özdemir, 1993; Holland et al, 1993); and healthy volunteers (Solch et al, 1991). In these studies, topical cyclosporine was administered from 1 to 5 times daily, in concentrations of 2% or less. Adverse events were minimal and consisted of transient burning, punctate epitheliopathy or keratitis. There were no serious adverse events, and only 6 patients were discontinued due to adverse events. No abnormal clinical laboratory data were reported in patients. Following topical administration, cyclosporine was generally not detected in blood or serum; however, low levels of cyclosporine have been reported.

#### In-House Animal Studies

The 3-month and 6-month studies in rabbits and the 1-year study in dogs evaluated cyclosporine ophthalmic emulsions at concentrations up to 0.4%, 1 drop in 1 eye, up to 6 times daily (study reports 1793-2936-5, 1995; 1793-2936-6, 1996; CHV-985-126, 1997). There was no evidence of local or systemic toxicity, and there were no histologic compound-related changes in the eye or any other organs or tissues. The only treatment-related effects were transient slight ocular discomfort and conjunctival hyperemia in the rabbit studies.

Blood concentrations of cyclosporin A in the topically-dosed animals were consistently low, even during the exaggerated dosing regimens. The majority of the individual blood concentrations were less than 1.0 ng/mL, which correlates with the lack of toxicity observed. The margin of safety for humans based on systemic drug exposure in animals is at least 740-fold.

#### 3.7.5.9 Discussion

##### Ocular Safety

Cyclosporine ophthalmic emulsion administered BID in concentrations from 0.05% to 0.4% for up to 3 months, and 0.05% and 0.1% for up to 6 months, was well tolerated locally in patients with moderate to severe KCS. Ocular adverse events were not unexpected with an ophthalmic disease and a topical study medication. The most common ocular adverse event was burning, which was more frequent with cyclosporine emulsion than vehicle in the Phase 3 studies. Other ocular adverse events reported by 3% to 6% of patients in either of the cyclosporine emulsion groups in the Phase 3 studies were stinging, visual disturbance (most often blurred vision),



conjunctival hyperemia, eye pain, discharge, pruritus, foreign body sensation, photophobia, and irritation.

There were no clinically significant differences among cyclosporine emulsion and vehicle-treated patients in visual acuity, intraocular pressure, or biomicroscopy throughout the Phase 2 and Phase 3 studies. Likewise, in the animal safety studies, there was no evidence of ocular toxicity in any of the parameters monitored, and there were no histologic compound-related changes in the eye during treatment 6 times daily for up to 1 year with cyclosporine emulsion in concentrations up to 0.4%.

Ocular microbial analyses of conjunctival bacterial isolates were performed in the Phase 2 study to address concerns that daily use of a topical ophthalmic immunosuppressive agent could predispose patients to ocular infections (study report 192371-001, 1997). In fact, cyclosporine emulsion treatment was associated with a decrease from baseline in the presence of abnormal organisms. Similar significant reductions of pathogenic organisms have been seen in dry-eye patients after punctal occlusion, suggesting that adequate tear production plays a role in the maintenance of normal ocular flora (Castillo et al, 1994). Thus cyclosporine emulsion may improve the ocular microbiology of KCS patients through its beneficial effects on the underlying dry-eye condition.

No bacterial or fungal ocular infections were reported in patients treated with cyclosporine ophthalmic emulsion. The reduction in the types of organisms cultured and the absence of ocular infections seen in these human studies are supported by a previous study in dogs with dry eyes treated with 2% cyclosporine in corn oil (Salisbury et al, 1995). Likewise, in the 6-month rabbit and 1-year dog studies, there were no opportunistic ocular infections. Thus overall there was no sign of harmful local immunosuppression during treatment with cyclosporine ophthalmic emulsion.

#### Systemic Safety

Cyclosporine ophthalmic emulsion administered BID in concentrations from 0.05% to 0.4% for up to 3 months, and 0.05% and 0.1% for up to 6 months, was well tolerated without significant systemic effects in patients with moderate to severe KCS. Systemic adverse events were reported at similar rates in the cyclosporine emulsion and vehicle groups. Overall, 5.8% (51/877) of the patients in the Phase 3 studies experienced a serious adverse event (SAE). The investigators

considered each of the SAEs to have either no relationship to study medication or unlikely to be related to study medication.

Clinically important adverse events that have been associated with oral cyclosporine include nephrotoxicity, hepatotoxicity, neurotoxicity, and malignant lymphomas (PDR-NEORAL<sup>®</sup>, 1998; PDR-SANDIMMUNE<sup>®</sup>, 1998). Such treatment-related toxicities were neither expected nor seen with the topical usage of the cyclosporine emulsion. There were no notable differences between the vehicle and cyclosporine emulsion groups in any blood chemistry or hematology findings, including renal and hepatic function tests. Those adverse events categorized as “visual disturbance” were most often described in terms of blurred vision. These were ocular in origin rather than a syndrome of central nervous system toxicity and cortical blindness as reported with systemic cyclosporine use (Ghalie et al, 1990; Memon et al, 1995; Nussbaum et al, 1995).

Three patients were diagnosed with a lymphoma, each considered unlikely to be related to study medication. The patients had received 0.1% cyclosporine emulsion for 5 to 12 weeks. One patient had a history of Sjögren’s syndrome; such patients have a substantially increased risk of lymphoma (Vitali et al, 1993). The other 2 patients had received long-term treatment of rheumatoid arthritis with methotrexate, which is known to be associated with malignant lymphomas (PDR - methotrexate, 1998).

Likewise, in the animal safety studies there was no evidence of systemic toxicity in any of the parameters monitored, and there were no histologic compound-related changes in any organs or tissues during treatment 6 times daily for up to 1 year with cyclosporine emulsion in concentrations up to 0.4%. Blood concentrations of cyclosporin A in the topically dosed animals were consistently low, even during the exaggerated dosing regimens. The margin of safety for humans based on systemic drug exposure in animals is at least 740-fold.

Systemic treatment of rheumatoid arthritis and psoriasis patients with oral cyclosporine (2.5 to 5 mg/kg/day) produced blood concentrations (mean ± SD) that ranged from a trough of  $74.9 \pm 46.7$  ng/mL to a  $C_{max}$  of  $655 \pm 186$  to  $728 \pm 263$  ng/mL (PDR - NEORAL<sup>®</sup>, 1998). In contrast, topical cyclosporine emulsion (1 to 2 µg/kg/day) produced mean blood trough cyclosporin A concentrations and  $C_{max}$  values of less than 0.1 ng/mL (study reports PK-96-018, 1996; PK-98-109, 1998; PK-98-112, 1998). These concentrations are at least 749 to 6,550 times

lower than the trough and  $C_{max}$  values seen with systemic therapeutic use. In 98.2% (544/554) of the analyzed samples, blood concentrations following topical ophthalmic administration of cyclosporine were below the assay's quantitation limit of 0.1 ng/mL. All 10 quantifiable samples were from patients receiving 0.1% cyclosporine emulsion; in no patient was the blood cyclosporine A concentration greater than 0.299 ng/mL. Comparison of trough blood cyclosporin A concentrations during multiple ocular dosing indicated no detectable accumulation.

#### 3.7.5.10 Conclusions

Cyclosporine ophthalmic emulsion administered BID in concentrations from 0.05% to 0.4% for up to 3 months, and 0.05% and 0.1% for up to 6 months, was well tolerated locally without significant systemic effects in patients with moderate to severe KCS, with or without Sjögren's syndrome. Topical cyclosporine ophthalmic emulsion produced minimal systemic exposure, which correlated with the lack of local and systemic toxicity found in these studies.

3.7.5.11 References

Study Report References

STUDY NO.	STUDY TITLE	VOLUME PAGE
1793-2936-5	AGN 192371 – cyclosporine ophthalmic emulsion: a three-month ocular and systemic toxicity study with a one-month recovery period in New Zealand white rabbits. Allergan, 1995.	vol. 14 p. 001
1793-2936-6	AGN 192371 – cyclosporine ophthalmic emulsion: a six-month ocular and systemic toxicity study with a two-month recovery period in New Zealand white rabbits. Allergan, 1996.	vol. 15 p. 001
192371-001	A dose-ranging study evaluating the safety, tolerability, and efficacy of cyclosporine (0.05, 0.1, 0.2, 0.4%) and vehicle ophthalmic emulsions in the treatment of moderate to severe keratoconjunctivitis sicca. Allergan, 1997.	vol. 27 p. 002
192371-002	A multicenter, double-masked, randomized, vehicle-controlled, parallel-group study of the safety and efficacy of cyclosporine 0.05% and 0.1% ophthalmic emulsions used twice daily for up to one year in patients with moderate to severe keratoconjunctivitis sicca. Allergan, 1999.	vol. 40 p. 001
192371-003	A multicenter, double-masked, randomized, vehicle-controlled, parallel-group study of the safety and efficacy of cyclosporine 0.05% and 0.1% ophthalmic emulsions used twice daily for up to one year in patients with moderate to severe keratoconjunctivitis sicca. Allergan, 1999.	vol. 60 p. 001

STUDY NO	STUDY TITLE	VOLUME PAGE
CHV-985-126	52-week ocular and systemic study of cyclosporine in dogs with an 8-week recovery period. Corning Hazleton Incorporated, 1997.	vol. 17 p. 001
K201	Study Report Synopsis (A single-center, double-masked clinical trial to assess safety, ocular tolerability, and initial efficacy of three doses of Sandimmune® ophthalmic ointment in the treatment of vernal keratoconjunctivitis and keratoconjunctivitis sicca). Sandoz 1994	vol. 85 p. 265
K203	Interoffice memorandum summarizing the data for Sandoz clinical study K-203. Allergan, 1995.	vol. 85 p. 267
K206	Interoffice memorandum summarizing the data for Sandoz clinical study K-206. Allergan, 1994.	vol. 85 p. 302
PK-96-018	Pharmacokinetic analysis of cyclosporin A in human blood for clinical study entitled "A dose-ranging study evaluating the safety, tolerability, and efficacy of cyclosporine (0.05, 0.1, 0.2, 0.4%) and vehicle ophthalmic emulsions in the treatment of moderate to severe keratoconjunctivitis sicca". Allergan, 1996.	vol. 19 p. 284

PK-98-109      Six month interim pharmacokinetic analysis of plasma concentrations for study 192371-002 titled, "A multicenter, double-masked, randomized, vehicle-controlled, parallel-group study of the safety and efficacy of cyclosporine 0.05% and 0.1% ophthalmic emulsions used twice daily for up to one year in patients with moderate to severe keratoconjunctivitis sicca". Allergan, 1998.      vol. 19 p. 357

STUDY NO	STUDY TITLE	VOLUME PAGE
PK-98-112	Interim report of blood cyclosporin A concentrations during one dosing interval for study 192371-002 titled, "A multicenter, double-masked, randomized, vehicle-controlled, parallel-group study of the safety and efficacy of cyclosporine 0.05% and 0.1% ophthalmic emulsions used twice daily for up to one year in patients with moderate to severe keratoconjunctivitis sicca". Allergan, 1998.	vol. 19 p. 371

Literature References

Belin MW, Bouchard CS, Frantz S, et al. Topical cyclosporine in high-risk corneal transplants. *Ophthalmology* 1989;96:1144-1150. [vol. 86 p. 027]

BenEzra D, Matamoros N, Cohen E. Treatment of severe vernal keratoconjunctivitis with cyclosporine A eyedrops. *Transplant Proc* 1988;20(Suppl 2):644-649. [vol. 86 p. 046]

Bleik JH, Tabbara KF. Topical cyclosporine in vernal keratoconjunctivitis. *Ophthalmology* 1991;98:1679-1684. [vol. 86 p. 062]

Castillo NM, Kosrirukvongs P, Gritz DC, et al. Quantitative ocular microbial flora of dry eye patients pre and post punctal occlusion [abstract]. *Invest Ophthalmol Vis Sci* 1994;35:1691. [vol. 86 p. 220]

Foulks GN, Pflugfelder SC, Lemp MA, et al. A randomized double-masked clinical trial to assess efficacy and safety of a 1% CsA-containing ophthalmic ointment vs. placebo in patients with keratoconjunctivitis sicca (KCS) associated with Sjögren's syndrome (SS) [abstract]. Invest Ophthalmol Vis Sci 1996;37:S646. (Study K206) [vol. 86 p. 288]

Ghalie R, Fitzsimmons WE, Bennett D, et al. Cortical blindness: a rare complication of cyclosporine therapy. Bone Marrow Transplant 1990;6:147-149. [vol. 86 p. 313]

Goichot-Bonnat EL, Pouliquen YJM. Topical cyclosporin A in high-risk keratoplasty. In: Cavanagh HD, ed. Transactions of the World Congress on the Cornea III. New York, NY: Raven Press; 1988:399-401. [vol. 86 p. 362]

Gündüz K, Özdemir Ö. Therapeutic uses of topical cyclosporine. Ann Ophthalmol 1993;25:182-186. [vol. 87 p. 007]

Gündüz K, Özdemir Ö. Topical cyclosporin treatment of keratoconjunctivitis sicca in secondary Sjögren's syndrome. Acta Ophthalmol 1994;72:438-442. [vol. 87 p. 012]

Gündüz K, Özdemir Ö. Topical cyclosporin as an adjunct to topical acyclovir treatment in herpetic stromal keratitis. Ophthalmic Res 1997;29:405-408. [vol. 87 p. 017]

Helms HA, Rapoza P, Stern KL, et al. A randomized double-masked clinical trial to assess the safety and comparative efficacy of three concentrations of a cyclosporine-containing ophthalmic ointment vs. placebo in patients with keratoconjunctivitis sicca (KCS) [abstract]. Invest Ophthalmol Vis Sci 1996;37:S646. (Study K203) [vol. 87 p. 021]

Hoffmann F, Wiederholt M. Lokale Behandlung des Hornhauttransplantates beim Menschen mit Ciclosporin A. Klin Monatsbl Augenheilkd 1985;187:92-96. [vol. 87 p. 043]

Hoffmann F, Wiederholt M. Local treatment of necrotizing scleritis with cyclosporin A. Cornea 1985/1986;4:3-7. [vol. 87 p. 048]

Holland EJ, Olsen TW, Ketcham JM, et al. Topical cyclosporin A in the treatment of anterior segment inflammatory disease. Cornea 1993;12:413-419. [vol. 87 p. 053]

Kervick GN, Pflugfelder SC, Haimovici R, et al. Paracentral rheumatoid corneal ulceration. *Ophthalmology* 1992;99:80-88. [vol. 87 p. 213]

Laibovitz RA, Solch S, Andriano K, et al. Pilot trial of cyclosporine 1% ophthalmic ointment in the treatment of keratoconjunctivitis sicca. *Cornea* 1993;12:315-323. [vol. 87 p. 228]

McCarty CA, Bansal AK, Livingston PM, et al. The epidemiology of dry eye in Melbourne, Australia. *Ophthalmology* 1998;105:1114-1119. [vol. 87 p. 320]

Memon M, deMagalhaes-Silverman M, Bloom EJ, et al. Reversible cyclosporine-induced cortical blindness in allogenic bone marrow transplant recipients. *Bone Marrow Transplant* 1995;15:283-286. [vol. 87 p. 326]

Nussbaum ES, Maxwell RE, Bitterman PB, et al. Cyclosporine A toxicity presenting with acute cerebellar edema and brainstem compression. *J Neurosurg* 1995;82:1068-1070. [vol. 88 p. 039]

PDR (Physicians' Desk Reference). Product information for methotrexate. Montvale, NJ: Medical Economics Company, Inc; 1998:1281-1285. [vol. 88 p. 084]

PDR (Physicians' Desk Reference). Product information for NEORAL<sup>®</sup> (cyclosporine). Montvale, NJ: Medical Economics Company, Inc; 1998:1882-1889. [vol. 88 p. 103]

PDR (Physicians' Desk Reference). Product information for SANDIMMUNE<sup>®</sup> (cyclosporine). Montvale, NJ: Medical Economics Company, Inc; 1998: 1898-1901. [vol. 88 p. 132]

Power WJ, Mullaney P, Farrell M, et al. Effect of topical cyclosporin A on conjunctival T cells in patients with secondary Sjögren's syndrome. *Cornea* 1993;12:507-511. [vol. 88 p. 224]

Salisbury M-AR, Kaswan RL, Brown J. Microorganisms isolated from the corneal surface before and during topical cyclosporine treatment in dogs with keratoconjunctivitis sicca. *Am J Vet Res* 1995;7:880-884. [vol. 88 p. 256]

Secchi AG, Tognon MS, Leonardi A. Topical use of cyclosporine in the treatment of vernal keratoconjunctivitis. *Am J Ophthalmol* 1990;110:641-645. [vol. 88 p. 333]



Secchi AG, Leonardi A, Tognon, S. Intraoperative use of mytomycin C and postoperative use of topical cyclosporine A in the treatment of tarsal vernal keratoconjunctivitis [abstract]. Invest Ophthalmol Vis Sci 1997;38:S1077. [vol. 88 p. 338]

Solch S, Nadler PI, Silverman MH. Safety and tolerability of two percent cyclosporine (Sandimmune®) ophthalmic ointment in normal volunteers. J Ocul Pharmacol 1991;7(4):301-312. [vol. 88 p. 341]

Vitali C, Bombardieri S, Moutsopoulos HM, et al. Preliminary criteria for the classification of Sjögren's syndrome. Results of a prospective concerted action supported by the European Community. Arthritis Rheum 1993;36:340-347. [vol. 89 p. 052]

Wiebking H-J, Mehlfeld TT. Lokale Behandlung von Hornhautulcera und Skleromalazien mit cyclosporin A. Fortschr Ophthalmol 1986;83:345-347. [vol. 89 p. 072]

Zhao J, Jin X. Immunological analysis and treatment of Mooren's ulcer with cyclosporin A applied topically. Cornea 1993;12:481-488. [vol. 89 p. 106]

Zhao J, Jin X. Local therapy of corneal allograft rejection with cyclosporine. Am J Ophthalmol 1995;119:189-194. [vol. 89 p. 114]

Zierhut M, Thiel H-J, Weidle EG, et al. Topical treatment of severe corneal ulcers with cyclosporin A. Graefes Arch Clin Exp Ophthalmol 1989;227:30-35. [vol. 89 p. 120]



### **3.8 DISCUSSION OF THE BENEFIT/RISK RELATIONSHIP AND PROPOSED ADDITIONAL STUDIES**

#### **3.8.1 BENEFIT/RISK ASSESSMENT OF CYCLOSPORINE OPHTHALMIC EMULSION IN THE TREATMENT OF DRY EYE**

Demographic studies indicate that KCS affects millions of people worldwide; up to 11% of people aged 30 to 60 years (Bjerrum, 1997) and up to 14.6% of people aged 65 years and older (Schein et al, 1997). Patients with dry-eye disease typically complain of symptoms of ocular discomfort, including a dry, gritty feeling, that is often accompanied by foreign body sensation. Burning and irritation, photophobia, blurred vision, and gradual contact lens intolerance can occur, and some patients are unable to cry irritative or emotional tears (Lubniewski and Nelson, 1990). Depending on the duration and severity of disease, damage to the ocular surface may be present and those with chronic, uncontrolled disease have an increased risk of ocular infections (Lemp and Chacko, 1997; Lubniewski and Nelson, 1990).

Dry-eye disease can be a severe, debilitating, and sight-threatening disease. Patients with moderate to severe dry eyes wake up every morning with the feeling of sand and grit in their eyes; during their day every blink and every bright light causes pain. Their quality of life is greatly diminished because their eyes are frequently sore and irritated. They are unable to tolerate dry climates and air conditioning and are embarrassed if they need to wear unsightly goggles. They are further frustrated, along with their physicians, with the hopelessness that there is no satisfactory treatment available.

Current treatment options for KCS are palliative, providing symptomatic relief without addressing the underlying mechanisms of the disease. In contrast, cyclosporine ophthalmic emulsion improves the signs and symptoms of KCS and reduces the ocular inflammation and immune reactivity associated with the disease, thereby providing therapeutic benefit. Systemic exposure from topical administration is minimal, and both concentrations of cyclosporine emulsion were well tolerated locally without significant systemic adverse effects.

##### **3.8.1.1 Benefits**

Using traditional clinical methods to assess improvement in objective and subjective measures of dry-eye disease, the Phase 3 studies demonstrated the efficacy of 0.05% and 0.1% cyclosporine ophthalmic emulsion (study reports 192371-002, 1999 and 192371-003, 1999).

Within each study, statistically significant improvements were seen with each concentration of cyclosporine emulsion beginning at month 1. After 6 months of treatment, 14 of the 15 objective signs and subjective symptoms evaluated showed significant improvement from baseline for each cyclosporine concentration in each Phase 3 study.

Statistically significant among-group differences favoring at least one of the cyclosporine concentrations vs vehicle were found for 4 key efficacy parameters: the objective signs of corneal staining and the categorized Schirmer tear test with anesthesia, and the subjective endpoints of blurred vision and REFRESH<sup>®</sup> use. Combining these 4 parameters into a single measure of efficacy, the percentage of responders at month 6 was statistically significantly greater with cyclosporine emulsion than with vehicle in each of the Phase 3 studies (50%, 44%, and 31% in study 002, and 43%, 46%, and 29% in study 003 for 0.05% cyclosporine, 0.1% cyclosporine, and vehicle, respectively). The benefits seen with cyclosporine emulsion are particularly important considering that the use of REFRESH<sup>®</sup> tears was permitted during the studies.

Improvements in the key efficacy parameters with cyclosporine emulsion were clinically relevant as well as statistically significant. Decreases in corneal staining indicate improved corneal health, with a smoother refractive surface and a reduced risk of infection and ocular discomfort. The improvement in corneal staining can have a beneficial effect on vision as well, and subjectively, patients experienced less blurred vision. Substantial and clinically important increases in tear production were seen in both studies after 6 months of treatment with 0.05% cyclosporine emulsion. Another indicator of disease severity is the frequency of artificial tear use. After treatment with 0.05% cyclosporine emulsion for 6 months, average REFRESH<sup>®</sup> use decreased. This suggests that patients' eyes felt better and that the need for frequent use was reduced.

Pretreatment (baseline) evaluations from the tertiary tests in the Phase 3 studies have confirmed the underlying immune-based inflammatory component of KCS. Patients with and without Sjögren's syndrome showed the presence of immune activation markers (HLA-DR and HLA-DQ), inflammation marker CD11a, and the inflammatory cytokine interleukin-6 (IL-6) (Tertiary Reports: Baudouin and Baudouin, 1999; Pflugfelder, 1999; Smith et al, 1999). These findings are in contrast to the low expression of IL-6, CD11a, and HLA-DR seen in normal eyes (Baudouin et al, 1997; Jones et al, 1994).

Cyclosporine emulsion reduced both inflammation and immune reactivity within the ocular surface of KCS patients with and without Sjögren's syndrome. After 6 months of treatment with 0.05% cyclosporine emulsion, statistically significant decreases were seen for IL-6, HLA-DR, and CD11a. CD3 and CD8 (total T cells and T-suppressor cells) also were decreased (Tertiary Reports: Gipson, 1999; Pflugfelder, 1999). Improvement of the ocular surface on a cellular level was demonstrated by an increased density of goblet cells in conjunctival biopsy samples (Tertiary Report: Gipson, 1999).

Cyclosporine emulsion also may benefit patients by improving the ocular microbiology of KCS through its effects on the underlying dry-eye condition. Ocular microbial analyses of conjunctival bacterial isolates were performed in the Phase 2 study to address concerns that daily use of a topical ophthalmic immunosuppressive agent could predispose patients to ocular infections (study report 192371-001, 1997). In fact, cyclosporine emulsion treatment was associated with a decrease from baseline in the presence of abnormal organisms. Similar significant reductions of pathogenic organisms have been seen in dry-eye patients after punctal occlusion, suggesting that adequate tear production plays a role in the maintenance of normal ocular flora (Castillo et al, 1994).

Cyclosporine ophthalmic emulsion positively influences the underlying mechanisms of dry-eye disease, thus providing therapeutic benefit. These effects were shown in both Phase 3 studies and confirmed in the tertiary test results.

#### 3.8.1.2 Risks

Overall, the Phase 2 and Phase 3 studies provided a safety database of 1039 patients with KCS, including 714 patients who were exposed to any concentration of cyclosporine ophthalmic emulsion. Cyclosporine ophthalmic emulsion administered BID in concentrations from 0.05% to 0.4% for up to 3 months, and 0.05% and 0.1% for up to 6 months was well tolerated locally without significant systemic effects in patients with moderate to severe KCS. Note that one drop in each eye BID of 0.05% cyclosporine emulsion delivers approximately 0.057 mg of cyclosporine per day, given a drop size of approximately 28.5  $\mu$ L, or less than 1  $\mu$ g/kg/day for a 60 kg patient.

Ocular adverse events were not unexpected with an ophthalmic disease and a topical study medication. The most common ocular adverse event was burning, which was more frequent

with cyclosporine emulsion than vehicle in the Phase 3 studies. Other ocular adverse events reported by 3% to 6% of patients receiving cyclosporine emulsion in the Phase 3 studies were stinging, visual disturbance, conjunctival hyperemia, eye pain, discharge, pruritus, foreign body sensation, photophobia, and irritation. No bacterial or fungal ocular infections were reported in patients treated with cyclosporine ophthalmic emulsion, and overall, there was no sign of harmful local immunosuppression.

There were no clinically significant differences among cyclosporine emulsion and vehicle-treated patients in visual acuity, intraocular pressure, or biomicroscopy throughout the Phase 2 and Phase 3 studies. Likewise, in the animal safety studies, there was no evidence of ocular toxicity in any of the parameters monitored, and there were no histologic compound-related changes in the eye during treatment 6 times daily for up to 1 year with cyclosporine emulsion in concentrations up to 0.4%.

Systemic adverse events were reported at similar rates with cyclosporine ophthalmic emulsion and vehicle. Clinically important adverse events that have been associated with oral cyclosporine include nephrotoxicity, hepatotoxicity, neurotoxicity, and malignant lymphomas. Such treatment-related toxicities were neither expected nor seen with topical usage of cyclosporine emulsion. There were no notable differences between the vehicle and cyclosporine emulsion groups in any blood chemistry or hematology findings, including renal and hepatic function tests.

Likewise, in the animal safety studies, there was no evidence of systemic toxicity in any of the parameters monitored, and there were no histologic compound-related changes in any organs or tissues during treatment 6 times daily for up to 1 year with cyclosporine emulsion in concentrations up to 0.4%. Blood concentrations of cyclosporin A in the topically dosed animals were consistently low, even during the exaggerated dosing regimens. The margin of safety for humans based on systemic drug exposure in animals is at least 740-fold.

Systemic treatment of rheumatoid arthritis and psoriasis patients with oral cyclosporine (2.5 to 5 mg/kg/day) produced blood concentrations (mean  $\pm$  standard deviation) that ranged from a trough of  $74.9 \pm 46.7$  ng/mL to a  $C_{max}$  of  $655 \pm 186$  to  $728 \pm 263$  ng/mL (PDR - NEORAL<sup>®</sup>, 1998). In contrast, topical cyclosporine emulsion (1 to 2  $\mu$ g/kg/day) produced mean blood trough cyclosporin A concentrations and  $C_{max}$  values of less than 0.1 ng/mL (study reports

PK-96-018, 1996; PK-98-109, 1998; PK-98-112, 1998). These concentrations are at least 749 to 6,550 times lower than the trough and  $C_{max}$  values seen with systemic therapeutic use. In 98.2% (544/554) of the analyzed samples, blood concentrations following topical ophthalmic administration of cyclosporine were below the assay's quantitation limit of 0.1 ng/mL. All 10 quantifiable samples were from patients receiving 0.1% cyclosporine emulsion; in no patient was the blood cyclosporin A concentration greater than 0.299 ng/mL. Comparison of trough blood cyclosporin A concentrations during multiple ocular dosing indicated no detectable accumulation.

### 3.8.1.3 Conclusions

In summary, 0.05% cyclosporine ophthalmic emulsion is proposed for approval for the treatment of moderate to severe KCS because it has proven benefits, is at least as effective as 0.1% cyclosporine emulsion, and is safe and well tolerated. This proposal is supported by the efficacy and safety of 0.05% and 0.1% cyclosporine emulsions demonstrated in a substantial clinical program:

- Clinically and statistically significant effects in favor of both concentrations of cyclosporine emulsion in a number of important parameters in the ITT population in each of the Phase 3 studies, as well as in a confirmatory meta-analysis of the ITT population. Notably, the cyclosporine formulations achieved clinically and statistically significant results versus vehicle for the individual parameters corneal staining, blurred vision, categorized Schirmer with anesthesia, and reduction in REFRESH<sup>®</sup> use, as well as in the responder analysis using all 4 parameters. In addition, improvement with the cyclosporine formulations was seen in virtually all efficacy parameters in the within-group analyses.
- Efficacy data for the traditional dry-eye study parameters in the ITT population are supported by results of the tertiary tests that showed reductions with 0.05% cyclosporine emulsion in the inflammation and immune reactivity underlying KCS. Notably, IL-6, CD11a, and HLA-DR were reduced. In addition, goblet cell density in conjunctival biopsies was elevated by the 0.05% cyclosporine emulsion.
- Analysis of a number of subpopulations from the clinical program supports the efficacy seen in the ITT population.

- Although the vehicle delivered a significant beneficial effect to patients, as expected with a formulation designed for the dry-eye population, all statistically significant results in the ITT among-group analyses favored cyclosporine over vehicle. This finding is particularly important when it is recalled that the use of REFRESH® tears was permitted as needed during the clinical studies.
- Cyclosporine ophthalmic emulsion administered BID in concentrations from 0.05% to 0.4% for up to 3 months, and 0.05% and 0.1% for up to 6 months, was well tolerated locally without significant systemic effects. Topical administration produced minimal systemic exposure, which correlated with the lack of systemic toxicity found in these studies.

Thus the benefits of improvement in signs and symptoms of dry eye and reduction in ocular surface inflammation seen with cyclosporine ophthalmic emulsion far outweigh the minimal risks associated with this treatment.

### 3.8.2 PROPOSED POST-MARKETING CLINICAL STUDIES OR SURVEILLANCE

The Integrated Summary of Safety is based on the safety data from the initial 6-month Vehicle-Controlled Masked Treatment portion of the Phase 3 studies 192371-002 and 192371-003 (NDA Section 8.7). No significant safety issues were identified in that review. Additional safety information obtained since datalock of these studies has not altered the original findings and conclusions (NDA Section 9). Patients who completed the Vehicle-Controlled Masked Treatment Phase are continuing in the 6-month Cyclosporine Treatment Extension Phase to provide further support for long-term usage.

Two open-label extension studies also are ongoing in patients with moderate to severe KCS who were previously dosed in the Phase 2 and Phase 3 studies (NDA Section 3.7.4). One additional study evaluating the safety and efficacy of 0.05% cyclosporine ophthalmic emulsion for up to 6 months in patients with mild to moderate KCS is currently under review (192371-006). No additional post-marketing or surveillance studies are ongoing.



3.8.3 REFERENCES

3.8.3.1 Study Report References

STUDY NO.	STUDY TITLE	VOLUME PAGE
192371-001	A dose-ranging study evaluating the safety, tolerability, and efficacy of cyclosporine (0.05, 0.1, 0.2, 0.4%) and vehicle ophthalmic emulsions in the treatment of moderate to severe keratoconjunctivitis sicca. Allergan, 1997.	vol. 27 p. 002
192371-002	A multicenter, double-masked, randomized, vehicle-controlled, parallel-group study of the safety and efficacy of cyclosporine 0.05% and 0.1% ophthalmic emulsions used twice daily for up to one year in patients with moderate to severe keratoconjunctivitis sicca. Allergan, 1999.	vol. 40 p. 001
192371-003	A multicenter, double-masked, randomized, vehicle-controlled, parallel-group study of the safety and efficacy of cyclosporine 0.05% and 0.1% ophthalmic emulsions used twice daily for up to one year in patients with moderate to severe keratoconjunctivitis sicca. Allergan, 1999.	vol. 60 p. 001
PK-96-018	Pharmacokinetic analysis of cyclosporin A in human blood for clinical study entitled "A dose-ranging study evaluating the safety, tolerability, and efficacy of cyclosporine (0.05, 0.1, 0.2, 0.4%) and vehicle ophthalmic emulsions in the treatment of moderate to severe keratoconjunctivitis sicca". Allergan, 1996.	vol. 19 p. 284

STUDY NO.	STUDY TITLE	VOLUME PAGE
PK-98-109	Six month interim pharmacokinetic analysis of plasma concentrations for study 192371-002 titled, "A multicenter, double-masked, randomized, vehicle-controlled, parallel-group study of the safety and efficacy of cyclosporine 0.05% and 0.1% ophthalmic emulsions used twice daily for up to one year in patients with moderate to severe keratoconjunctivitis sicca". Allergan, 1998.	vol. 19 p. 357
PK-98-112	Interim report of blood cyclosporin A concentrations during one dosing interval for study 192371-002 titled, "A multicenter, double-masked, randomized, vehicle-controlled, parallel-group study of the safety and efficacy of cyclosporine 0.05% and 0.1% ophthalmic emulsions used twice daily for up to one year in patients with moderate to severe keratoconjunctivitis sicca". Allergan, 1998.	vol. 19 p. 371
Tertiary Report: Conjunctival Biopsies (NEI)	Investigator Summary Report of Baseline Data for Conjunctival Biopsies (Protocol NEI 98-E1-0032). JA Smith (NEI), SM Whitcup (NEI), and ME Stern (Allergan), 1999.	vol. 85 p. 001
Tertiary Report: Flow Cytometry	Investigator Summary Report of Baseline Data for Flow Cytometry (Protocol 192371-501). C Baudouin and F Baudouin (Ambroise Paré Hospital), 1999.	vol. 85 p. 008

STUDY NO.	STUDY TITLE	VOLUME PAGE
Tertiary Report: IL-6	Investigator Summary Report of Tertiary Tests of Inflammatory Cytokine Interleukin-6 (Protocol 192371-003). S Pflugfelder (University of Miami), 1999.	vol. 85 p. 016
Tertiary Report: Conjunctival Biopsies	Investigator Summary Report of Tertiary Tests of Conjunctival Biopsies (Protocols 192371-002 and 192371-003). IK Gipson (Schepens Eye Research Institute), 1999.	vol. 85 p. 029

### 3.8.3.2 Literature References

Baudouin C, Brignole F, Becquet F, et al. Flow cytometry in impression cytology specimens. A new method for evaluation of conjunctival inflammation. Invest Ophthalmol Vis Sci 1997;38:1458-1464. [vol. 86 p. 020]

Bjerrum KB. Keratoconjunctivitis sicca and primary Sjögren's syndrome in a Danish population aged 30-60 years. Acta Ophthalmol Scand 1997;75:281-286. [vol. 86 p. 056]

Castillo NM, Kosrirukvongs P, Gritz DC, et al. Quantitative ocular microbial flora of dry eye patients pre and post punctal occlusion [abstract]. Invest Ophthalmol Vis Sci 1994;35:1691. [vol. 86 p. 220]

Jones DT, Monroy D, Ji Z, et al. Sjögren's syndrome: cytokine and Epstein-Barr viral gene expression within the conjunctival epithelium. Invest Ophthalmol Vis Sci 1994;35:3493-3504. [vol. 87 p. 115]

Lemp MA, Chacko B. Diagnosis and treatment of tear deficiencies. In: Tasman W, Jaeger E, eds. Duane's Clinical Ophthalmology. Philadelphia, PA: Harper and Row; 1997; chapter 14:1-13 (updated 1991). [vol. 87 p. 249]

Lubniewski AJ, Nelson JD. Diagnosis and management of dry eye and ocular surface disorders. Ophthalmol Clin of North Am 1990;3:575-594. [vol. 87 p. 262]

PDR (Physicians' Desk Reference). Product information for NEORAL<sup>®</sup> (cyclosporine).

Montvale, NJ: Medical Economics Company, Inc; 1998:1882-1889. [vol. 88 p. 103]

Schein OD, Munoz B, Tielsch JM, et al. Prevalence of dry eye among the elderly. Am J Ophthalmol 1997;124:723-728. [vol. 88 p. 311]