



US008966144B2

(12) **United States Patent**  
**Tasler**

(10) **Patent No.:** **US 8,966,144 B2**  
(45) **Date of Patent:** **\*Feb. 24, 2015**

(54) **ANALOG DATA GENERATING AND PROCESSING DEVICE HAVING A MULTI-USE AUTOMATIC PROCESSOR**

(58) **Field of Classification Search**  
USPC ..... 710/1, 15, 63  
See application file for complete search history.

(75) Inventor: **Michael Tasler, Würzburg (DE)**

(56) **References Cited**

(73) Assignee: **Papst Licensing GmbH & Co. KG, St. Georgen (DE)**

U.S. PATENT DOCUMENTS

(\* ) Notice: Subject to any disclaimer, the term of this patent is extended or adjusted under 35 U.S.C. 154(b) by 1333 days.

This patent is subject to a terminal disclaimer.

3,714,635 A 1/1973 Hamilton et al.  
3,805,245 A 4/1974 Brooks et al.

(Continued)

FOREIGN PATENT DOCUMENTS

DE 3624373 A1 1/1987  
DE 88 G 3559 3/1989

(Continued)

OTHER PUBLICATIONS

"OpenHCI Specification for USB" by Compaq, Microsoft, National Semiconductor, Oct. 10, 1996, Release V1.0a, pp. 1-146.\*

(Continued)

(21) Appl. No.: **11/467,073**

(22) Filed: **Aug. 24, 2006**

(65) **Prior Publication Data**

US 2007/0005823 A1 Jan. 4, 2007

**Related U.S. Application Data**

(60) Continuation of application No. 11/078,778, filed on Mar. 11, 2005, now abandoned, and a continuation of application No. 10/219,105, filed on Aug. 15, 2002, now Pat. No. 6,895,449, which is a division of application No. 09/331,002, filed on Jun. 14, 1999, now Pat. No. 6,470,399.

*Primary Examiner* — Chun-Kuan Lee

(74) *Attorney, Agent, or Firm* — The Meola Firm, PLLC

(30) **Foreign Application Priority Data**

Mar. 4, 1997 (DE) ..... 19708755  
Mar. 3, 1998 (WO) ..... PCT/EP98/01187

(57) **ABSTRACT**

An interface device (10) provides fast data communication between a host device with input/output interfaces and a data transmit/receive device, wherein the interface device (10) comprises a processor means (13), a memory means (14), a first connecting device (12) for interfacing the host device with the interface device, and a second connecting device (15) for interfacing the interface device (10) with the data transmit/receive device. The interface device (10) is configured by the processor means (13) and the memory means (14) in such a way that, when receiving an inquiry from the host device via the first connecting device (12) as to the type of a device attached to the host device, regardless of the type of the data transmit/receive device, the interface device sends a signal to the host device via the first connecting device (12) which signals to the host device that it is communicating with an input/output device.

(51) **Int. Cl.**  
**G06F 13/12** (2006.01)  
**G06F 13/38** (2006.01)  
**G06F 3/06** (2006.01)

(52) **U.S. Cl.**  
CPC ..... **G06F 13/385** (2013.01); **G06F 3/0605** (2013.01); **G06F 3/0607** (2013.01);

(Continued)

**87 Claims, 2 Drawing Sheets**

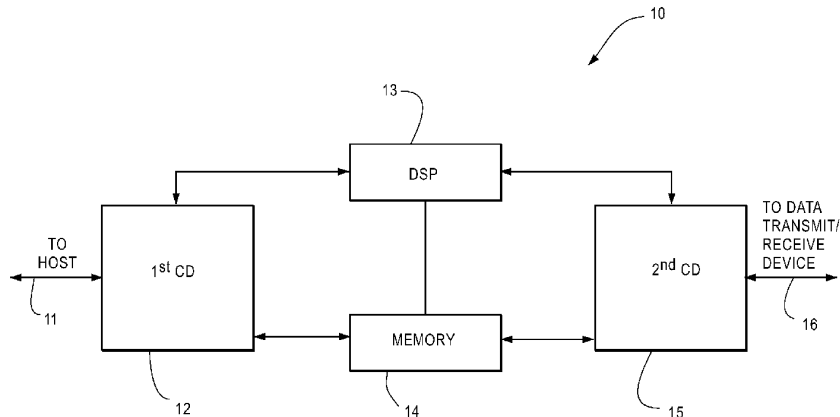

(52) **U.S. Cl.**  
 CPC ..... *G06F3/0613* (2013.01); *G06F 3/0661*  
 (2013.01); *G06F 3/0664* (2013.01); *G06F*  
*3/0676* (2013.01); *G06F 13/387* (2013.01)  
 USPC ..... **710/63**

(56) **References Cited**

U.S. PATENT DOCUMENTS

3,976,979	A	8/1976	Parkinson et al.	5,581,741	A	12/1996	Clark et al.
4,041,473	A	8/1977	Bardotti et al.	5,596,628	A	1/1997	Klein
4,420,773	A	12/1983	Toyoda et al.	5,614,344	A	3/1997	Kawakami et al.
4,466,573	A	8/1984	Camboulives et al.	5,614,670	A	3/1997	Nazarian et al.
4,509,113	A	4/1985	Heath	5,614,948	A	* 3/1997	Hannah ..... 348/255
4,642,759	A	2/1987	Foster	5,619,659	A	4/1997	Kikinis et al.
4,652,928	A	* 3/1987	Endo et al. .... 348/219.1	5,625,800	A	4/1997	Brayton et al.
4,680,732	A	7/1987	DiCenzo	5,625,840	A	4/1997	Numata et al.
4,787,027	A	11/1988	Prugh et al.	5,628,030	A	5/1997	Tuckner
4,888,680	A	12/1989	Sander et al.	5,630,164	A	5/1997	Williams et al.
4,896,262	A	1/1990	Wayama et al.	5,634,075	A	* 5/1997	Smith et al. .... 710/9
4,901,275	A	2/1990	Hardie et al.	5,638,299	A	6/1997	Miller
4,972,470	A	11/1990	Farago	5,639,606	A	6/1997	Willey
5,014,186	A	5/1991	Chisholm	5,640,204	A	6/1997	Tsutsui
5,034,598	A	7/1991	Poland	5,663,901	A	9/1997	Wallace et al.
5,070,474	A	12/1991	Tuma et al.	5,668,976	A	9/1997	Zook
5,088,033	A	2/1992	Binkley et al.	5,689,710	A	11/1997	Stanley et al.
5,129,036	A	7/1992	Dean et al.	5,692,159	A	11/1997	Shand
5,131,089	A	7/1992	Cole	5,696,970	A	12/1997	Sandage et al.
5,197,128	A	3/1993	Campbell et al.	5,703,584	A	12/1997	Hill
5,214,761	A	5/1993	Barrett et al.	5,712,682	A	1/1998	Hannah
5,214,785	A	5/1993	Fairweather	5,724,155	A	3/1998	Saito
5,226,168	A	7/1993	Kobayashi et al.	5,724,574	A	3/1998	Stratigos et al.
5,230,065	A	7/1993	Curley et al.	5,742,934	A	* 4/1998	Shinohara ..... 711/103
5,231,501	A	7/1993	Sakai	5,748,924	A	5/1998	Llorens et al.
5,275,327	A	1/1994	Watkins et al.	5,754,227	A	5/1998	Fukuoka
5,291,584	A	3/1994	Challa et al.	5,764,546	A	6/1998	Bryant et al.
5,291,611	A	3/1994	Davis et al.	5,765,027	A	6/1998	Wang et al.
5,296,611	A	3/1994	Solladie et al.	5,778,205	A	7/1998	Orimoto
5,297,124	A	3/1994	Plotkin et al.	5,778,384	A	7/1998	Provino et al.
5,303,326	A	4/1994	Dean et al.	5,784,581	A	7/1998	Hannah
5,357,519	A	* 10/1994	Martin et al. .... 714/25	5,790,193	A	8/1998	Ohmori
5,369,484	A	11/1994	Haugen	5,794,032	A	8/1998	Leyda
5,371,885	A	12/1994	Letwin	5,802,325	A	9/1998	Le Roux
5,379,382	A	1/1995	Work et al.	5,802,385	A	9/1998	Densham et al.
5,386,518	A	1/1995	Reagle et al.	5,806,072	A	9/1998	Kuba et al.
5,402,170	A	3/1995	Parulski et al.	5,812,879	A	9/1998	Moro
5,428,357	A	6/1995	Haab et al.	5,815,201	A	9/1998	Hashimoto
5,430,855	A	7/1995	Walsh et al.	5,815,205	A	9/1998	Hashimoto et al.
5,440,699	A	8/1995	Farrand et al.	5,822,614	A	10/1998	Kenton et al.
5,444,644	A	8/1995	Divjak	5,841,471	A	11/1998	Endsley et al.
5,457,784	A	10/1995	Wells et al.	5,844,961	A	12/1998	McEvoy et al.
5,457,785	A	10/1995	Kikinis et al.	5,845,094	A	12/1998	Beauchamp et al.
5,463,772	A	10/1995	Thompson et al.	5,848,420	A	12/1998	Xu
5,465,106	A	11/1995	Keech et al.	5,854,905	A	12/1998	Garney
5,473,765	A	12/1995	Gibbons et al.	5,854,949	A	12/1998	Furukawa et al.
5,475,441	A	12/1995	Parulski et al.	5,871,368	A	2/1999	Erdner et al.
5,479,206	A	12/1995	Ueno et al.	5,875,415	A	2/1999	Lieb et al.
5,487,154	A	1/1996	Gunji	5,877,975	A	3/1999	Jigour et al.
5,493,335	A	2/1996	Parulski et al.	5,878,248	A	3/1999	Tehrani et al.
5,499,378	A	3/1996	McNeill, Jr. et al.	5,881,366	A	3/1999	Bodenmann et al.
5,506,617	A	4/1996	Parulski et al.	5,884,103	A	3/1999	Terho et al.
5,506,692	A	4/1996	Murata	5,892,939	A	4/1999	Call et al.
5,508,821	A	4/1996	Murata	5,914,748	A	* 6/1999	Parulski et al. .... 348/239
5,510,774	A	4/1996	Phillips	5,915,106	A	6/1999	Ard
5,515,474	A	5/1996	Deacon et al.	5,917,545	A	6/1999	Kowno et al.
5,524,047	A	6/1996	Brown et al.	5,920,709	A	7/1999	Hartung et al.
5,528,765	A	6/1996	Milligan	5,923,193	A	7/1999	Bloch et al.
5,530,858	A	6/1996	Stanley et al.	5,926,208	A	7/1999	Noonen et al.
5,532,825	A	7/1996	Lim et al.	5,928,347	A	7/1999	Jones et al.
5,537,597	A	7/1996	Sandage	5,929,903	A	7/1999	Kiesow
5,539,535	A	7/1996	Aizawa et al.	5,930,480	A	7/1999	Staats
5,548,782	A	8/1996	Michael et al.	5,935,224	A	8/1999	Svancarek et al.
5,548,783	A	8/1996	Jones et al.	5,937,423	A	8/1999	Robinson
5,570,146	A	10/1996	Collette	5,946,386	A	8/1999	Rogers et al.
5,574,859	A	11/1996	Yeh	5,948,091	A	* 9/1999	Keigan et al. .... 710/10
5,576,757	A	* 11/1996	Roberts et al. .... 348/220.1	5,969,750	A	* 10/1999	Hsieh et al. .... 348/14.1
5,579,529	A	11/1996	Terrell et al.	5,974,161	A	10/1999	York
				5,991,530	A	11/1999	Okada et al.
				5,995,080	A	11/1999	Biro et al.
				6,005,613	A	12/1999	Endsley et al.
				6,012,113	A	1/2000	Tuckner
				6,014,430	A	1/2000	Gosney et al.
				6,023,292	A	2/2000	Wakui
				6,026,217	A	2/2000	Adiletta
				6,029,215	A	2/2000	Watts, Jr. et al.
				6,067,584	A	5/2000	Hayles et al.
				6,081,856	A	6/2000	Comer
				6,086,430	A	7/2000	Amoni et al.

(56)

## References Cited

## U.S. PATENT DOCUMENTS

6,088,532	A	7/2000	Yamamoto et al.
6,094,219	A	7/2000	Roberts et al.
6,098,116	A	8/2000	Nixon et al.
6,101,276	A	8/2000	Adiletta et al.
6,104,430	A	8/2000	Fukuoka
6,111,604	A *	8/2000	Hashimoto et al. .... 348/220.1
6,119,180	A	9/2000	Terho et al.
6,131,125	A	10/2000	Rostoker et al.
6,147,703	A	11/2000	Miller et al.
6,149,316	A	11/2000	Harari et al.
6,163,344	A	12/2000	Kawamura et al.
6,182,145	B1	1/2001	Schuman et al.
6,188,675	B1	2/2001	Casper et al.
6,256,319	B1	7/2001	Apgar et al.
6,256,452	B1	7/2001	Yamamoto
6,260,102	B1	7/2001	Robinson
6,286,073	B1	9/2001	Vegter
6,292,589	B1	9/2001	Chow et al.
6,298,388	B1	10/2001	Taguchi
6,344,875	B1	2/2002	Hashimoto et al.
6,424,809	B1	7/2002	Yamamoto et al.
6,441,854	B2	8/2002	Fellegara et al.
6,470,399	B1	10/2002	Tasler
6,654,050	B2	11/2003	Karube et al.
6,670,985	B2	12/2003	Karube et al.
6,895,449	B2	5/2005	Tasler
7,046,276	B2	5/2006	Hashimoto et al.
2001/0050711	A1	12/2001	Karube et al.

## FOREIGN PATENT DOCUMENTS

DE	390 332	B	4/1990
DE	41 37 928	A1	5/1992
DE	195 28 889	A1	8/1995
DE	296 07 724	U1	4/1996
DE	195 28 889	A1	2/1997
EP	0 03 044		4/1984
EP	0 259 786	A1	9/1987
EP	0 391 157	A2	3/1990
EP	0 685 799	A1	5/1995
EP	0 705 037	A2	3/1996
JP	53145535	A	12/1978
JP	61034652	A	2/1986
JP	61060164	A	3/1986
JP	63-133204		6/1988
JP	01303554	A	7/1989
JP	01293404	A	11/1989
JP	02-051727		2/1990
JP	02114351	A	4/1990
JP	03-246654		11/1991
JP	04-133152		5/1992
JP	04-213715		8/1992
JP	04-309156		10/1992
JP	06-052087		2/1994
JP	06-067815		3/1994
JP	06-83917		3/1994
JP	06-090423		3/1994
JP	06-301607		10/1994
JP	6-301607		10/1994
JP	07-044290		2/1995
JP	07-177406		7/1995
JP	07-202982		8/1995
JP	8-110883		4/1996
JP	08-110883		4/1996
JP	08-130702		5/1996
JP	H8-130702	*	5/1996
JP	08-191375		7/1996
JP	8-191410		7/1996
JP	08-191412		7/1996
JP	08-223341		8/1996
JP	08-328990		12/1996
JP	09016506	A	1/1997

JP	09-091237	4/1997
JP	10-177535	6/1998
WO	WO 94/19746	9/1994

## OTHER PUBLICATIONS

Robert Ristelhueber, "Plug and play is almost here. (automatic configuration of PCs and peripherals)," May 1994, Electronic Business Buyer, v20 , n5 , pp. 43-45.\*

Analogic Corporation, "SCSI Real-Time Video Frame Grabber", 1992, 4 pages.\*

Printouts made in 2007 from three web pages that concern commercial information about the Nikon Coolpix 100 camera. (English).

Manual for Nikon Coolpix 100 camera that was downloaded from Nikon's web site in 2007. (English).

Photocopies of materials that came with a used Nikon Coolpix 100 camera that was purchased in 2007 in Europe. (German and English).

A printout showing the file directory structure of the files contained in a CD-ROM that came with a used Nikon Coolpix 100 camera that was purchased in Europe in 2007. (English).

A file called "COOLPIX.PDF" that is stored in the CD-ROM that came with the used Nikon Coolpix camera that was purchased in Europe in 2007, the document contained in this file being entitled "Nikon Camara Digital Coolpix 100 Manual del Usuario." (Spanish).

Pictures of a used Nikon Coolpix 100 camera that was purchased in the United States in 2007, one of the pictures showing the camera in a disassembled state.

A Nikon Coolpix 100 camera manual that was purchased in 2007 in the United States. (English).

Manual for Sony Digital Still Camera DSC-F1 (60 pages).

Sony PC Connecting Kit—Operating Instructions (127 pages).

Sony DSC-F1 Digital Still Camera (2 page).

Manual for Canon EOS-DCS 3C Digital Camera (314 pages).

Spec Sheet for Canon EOS-DCS 3C Digital Camera (2 pages).

Spec Sheet for Canon PS600 Digital Camera (1 page).

Information Regarding Olympus Camedia C-800L Digital Camera.

Kodak DC20 Camera Manual (37 pages).

Kodak DC 25 Camera Manual (47 pages).

Kodak Picture Easy Software (1 page).

Kodak Picture Works Software (2 pages).

Universal Serial Bus Specification, 1.0 Final Draft Revision, Nov. 13, 1995.

Universal Serial Bus Specification, Revision 1.0, Jan. 15, 1996.

Brochure for Nikon Coolpix 100 camera (English translation provided) (8 pages).

Nikon COOLPIX 100 Specification (4 pages).

Technical Specs—QV-10A—QV Series—Cameras—Products—CASIO (1 page).

QV-LINK Version 2.0 for Window (qmlink-readme.txt) (5 pages).

QV-10B Owner's Manuel (Casio) (23 pages).

IEEE Standard for High Performance Serial Bus, 1996. 392 pp. (IEEE Std 1394-1995).

Digidesign 882/20 I/O Audio Interface Installation Guide, 14 pp.

Information Technology—Serial Bus Protocol 2 (SBP -2), T10 Project 1155D, Revision 4, May 19, 1998, 107 pp.

An American National Standard, IEEE Standard for a Simple 32-Bit Backplane Bus: NuBus; 1998, 51 pp. (ANSI/IEEE 1196-1987).

Polaroid Digital Camera PDC-2000 User Guide for Macintosh or Windows applications (142 pp.).

apple-history.com, Macintosh Quadra 650 (with NuBus Slots), Apple Computer, Inc., (produce introduced Oct. 93) Nov. 29, 2005, 2 pp.

Wang, James www.sims.berkeley.edu Third Party NuBus AV (Audio-Video) Cards, 1993-1996 1 pg.

Accredited Standards Committee X3, Information Technology, John Lohmeyer, X3T10/96-202r1, Agenda and Results of Meeting, X3T10 SCSI Working Group Meeting, Jul. 24, 1996 (6 pp.).

Intel Corporation, Universal Host Controller Interface Design Guide (UHCI), Revision 1.1, Mar. 1996 (47 pp.).

Twain Working Group Committee, Twain Toolkit Release V1.6, Twain Specification Release, Feb. 5, 1996 (367 pp.).

(56)

## References Cited

## OTHER PUBLICATIONS

- Digidesign Website, www.digidesign.com, Tabular cross-reference "Pro Tools 4.0.1 NuBus Systems Compatibility" as supported by Digidesign, Inc., Palo Alto, CA, 3 pp.
- Twain Working Group, www.twain.org, About Twain, 4 pp.
- Pournelle Alex, Jetsend Technology Allows Device connectivity with No Servers, Drivers, or Code, Computer Technology Review, Jul. 1999, vol. 19, Iss. 7, p. 22, 4 pp.
- Business Editors/Technology Writers, Salutation Port-of-Entry Software Lets Application Developers Control Network Peripherals from the Windows Desktop, Business Wire, Jul. 13, 1998, p. 1 (3 pp.).
- Wire Feed, HP Introduces JetSend for Pocket PC JetSend Solutions Now Compatible with Complete Range of Microsoft Windows CE-and Pocket PC-based Products, M2 Presswire, Apr. 26, 2000, p. 1 (3 pp.).
- Stedman, John HP and TROY Group Extend JetSend Protocol to Simplify Printing Over Networks and the Internet; JetSend Protocol Expands Cutting-edge Capabilities to Non-HP Printers, HP Deskjet Printers, Legacy HP LaserJet Printers and Future Products, M2 Presswire, Feb. 10, 2000, p. 1 (2 pp.).
- Business Editors, An Industry First, TROY Group's NetSend Makes Up to 9 Million HP Legacy Printers Internet-Ready, Business Wire, Nov. 16, 1999, p. 1 (3 pp.).
- Keele, Richard Designing Control Units that Interface Peripherals to the IBM I/O Channel, Computer Technology Review, Fall 1988; vol. 8, Iss. 13, p. 71 (1 page).
- Lang, Michael Optical Server Uses Network Protocol for Plug-and Play Integration, Computer Technology Review, Dec. 1993, vol. 13, Iss. 15, p. 85 (3 pp.).
- Bursky, Dave Inter-System Communication Standard to Ease Clustered System Implementation, Electronic Design, Oct. 13, 1997, vol. 45, Iss. 22, p. 32 (3 pp.).
- Hadden, Thomas H., Tape Drive Without Backup Software? Wait No More, Computer Technology Review Los Angeles, Oct. 1995, vol. 15 Iss. 10, p. 34 (4 pp.).
- Ferelli, Mark, 12-inch WORM becomes the key to document image processing Computer Technology Review Los Angeles, Mar. 1994, vol. 14, Iss. 3, p. 1 (3 pp.).
- Nelson, Andy Catching a Direct Bus, InfoWorld, Jun. 17, 1996, vol. 18, Iss. 25, p. 129 (2 pp.).
- DeMonker, Judy 120 Moves Into Clustering, Storage Arenas, InfoWorld, Dec. 9, 1996, vol. 18, Iss. 50, p. 37 (2 pp.).
- Krause, Reinhardt I/O Driver Spec to be Unveiled, Electronic News, Jan. 29, 1996, vol. 42, Iss. 2101, p. 1 (3 pp.).
- Microsoft Windows 95 README for MS-DOS Device Drivers, Aug. 1995, p. 1 (2 pp.).
- Lang, Michael Optical server uses network protocols for plug-and-play integration, Computer Technology Review: Special Fall Issue, Los Angeles, Dec. 1993, vol. 13, Iss. 15 p. 85 (6 pp.).
- IEEE Standard for a High Performance Serial Bus, 1996. 392 pp. (IEEE Std 1394-1995).
- apple-history.com, Macintosh Quadra 650 (with NuBus Slots), Apple Computer, Inc., (produce introduced Oct. 1993) Nov. 29, 2005, 2 pp.
- Accredited Standards Committee X3, Information Technolgy, John Lohmeyer, X3T10/96-202r1, Agenda and Results of Meeting, X3T10 SCSI Working Group Meeting, Jul. 24, 1996 (6 pp.).
- Colloquium on "PC-Based Instrumentation" Martin, Steve; Digest No. 1990/025, The Institution of Electrical Engineers, London (4 pages).
- High Speed PC-based Data Acquisition Systems, Payne, Jeffrey R, Bradford A. Menz, et al.; 1995 IEEE, pp. 2140-2145.
- Implementing Remote Procedure Calls, Birrell, Andrew D. and Nelson, Bruce Jay; Xerox Palo Alto Research Center, ACM Transactions on Computer Systems, vol. 2, No. 1, Feb. 1984, pp. 39-59.
- QV-10 Digital Camera—News Release Nov. 14, 1994 (Feb. 1995 correction) Portable Image Information Equipment of Multimedia Age—Liquid Crystal Digital Camera of Compact Size (Jun. 7, 2007) CAP-020276 (interne web pages) 4 pages.
- It's the Most Effective, Cost-Sensitive Way to Publish Your Inventions; IBM Technical Disclosure Bulletin, vol. 38, No. 5, May 1995 (4 pages) CAP-020280.
- Casio's QV-10: Portable Presentations (Oct. 1995) (2 pages).
- About.com: Inventors—History of the Digital Camera, Bellis, Mary, 2 pages.
- Wikipedia: Digital Camera (13 pages).
- A Brief Info on Kodak DCS-Series Digital Still SLR Cameras (10 pages).
- A Brief Info on Kodak DCS-Series Digital Still SLR Cameras Part II—DCS-400 Series with Nikon N90(s)/F90(x) Body Chassis (10 pages).
- Card Information Structure of Nikon Coolpix 100 Memory.
- USB: A Neat Package With a Fee Loose Ends; Author: Richard A. Quinnell; pp. 38-52; EDN Date: Oct. 24, 1996.
- Thesis: Design and Construction of a Universal Data Acquisition and Control System for Scanning Probe Microscopy, Michael Tasler, The University of Texas at Austin, May 1996 (100 pages).
- Plug and Play SCSI Specification, Version 1.0, Mar. 30, 1994 (26 pages).
- Clarifications to the Plug and Play ISA Specification, Version 1.0a, Dec. 10, 19994 (Based on the results of the Plugfests held Jun. 6-8 and Oct. 11-13, 1994), (28 pages).
- Plug and Play ISA Specification, Version 1.0a, May 5, 1994 (71 pages).
- The SCSI Bus and IDE Interface Book; Author: Friedhelm Schmidt; Publication Date: Jun. 17, 1995 (German version published in 1993).
- "Device Class Definition for Human Interface Devices (HID)" version 1.0—Final; Publication Date: Jun. 21, 1997.
- "Derived Virtual Devices: A Secure Distributed File System Mechanism"; Publication Date: Sep. 17, 1996.
- Camera Manufacturers Invalidation Contentions; Jun. 18, 2008.
- Exhibit A to Reference No. 22.
- Data Disasters: What Not to Do; Author; Michael Lang; Date: Dec. 1993.
- PC-based Data Acquisition in an Industrial Environment; Author: Steve Martin; Date: 1990.
- Jul. 1996 Apple article on SCSI drivers; Date: Jul. 3, 1996.
- Designing Control Units; Author: Richard Keele; Date: Jan. 31, 1989.
- Exhibit A40—Case 1:07-mc-00493-RCM; Document 139-42; Filed Jun. 18, 2008; p. 1 of 16.
- Exhibit A41—Case 1:07-mc-00493-RCM; Document 139-43; Filed Jun. 18, 2008; p. 1 of 16.
- Exhibit A42—Case 1:07-mc-00493-RCM; Document 139-44; Filed Jun. 18, 2008; p. 1 of 16.
- Exhibit A43—Case 1:07-mc-00493-RCM; Document 139-45; Filed Jun. 18, 2008; p. 1 of 16.
- Exhibit A44—Case 1:07-mc-00493-RCM; Document 139-46; Filed Jun. 18, 2008; p. 1 of 16.
- Exhibit A45—Case 1:07-mc-00493-RCM; Document 139-47; Filed Jun. 18, 2008; p. 1 of 16.
- Exhibit A46—Case 1:07-mc-00493-RCM; Document 139-48; Filed Jun. 18, 2008; p. 1 of 16.
- Exhibit A47—Case 1:07-mc-00493-RCM; Document 139-49; Filed Jun. 18, 2008; p. 1 of 16.
- Case 1:07-mc-00493-RCM; Document 160; Filed Jun. 30, 2008.
- Case 1:07-mc-00493-RCM; Document 160-2; Filed Jun. 30, 2008.
- Case 1:07-mc-00493-RCM; Document 160-3; Filed Jun. 30, 2008.
- "About the SCSI Manager," Developer Connection—Inside Macintosh: Devices / Chapter 3-SCSI Manager (6 pgs), © Apple Computer, Inc., Jul. 3, 1996.
- Clarifications to Plug and Play ISA Specification, Version 1.0a.
- "Digital Video Camera Recorder—Digital Handycam DCR-VX1000," © 1995 by Sony Corporation.
- "LK-12S for Windows 95—Connection Kit for the Casio LCD Digital Camera," QV-Link, Version 2.6 Owner's Manual.
- "Plug and Play ISA Specification," Version 1.0a, © 1993,1994 by Intel Corporation and Microsoft Corporation.
- "Plug and Play SCSI Specification," Version 1.0, © 1994 by Adaptec, AT&T Global Information Solutions, Digital Equip. Corp., Future Domain, Maxtor and Microsoft.

(56)

## References Cited

## OTHER PUBLICATIONS

- "Salutation Port-of-Entry Software Lets Application Developers Control Network Peripherals from the Windows Desktop," Desktop Business Wire, Inc., San Jose, CA, Jul. 13, 1998.
- "The SCSI Bus and IDE Interface," Addison-Wesley, Sect. 4.2-25.2, pp. 183-301.
- "Universal Serial Bus," [http://www.homestayfinder.com/Dictionary.aspx?q=Universal\\_Serial\\_Bus](http://www.homestayfinder.com/Dictionary.aspx?q=Universal_Serial_Bus).
- "Universal Serial Bus," Wikipedia, <http://www.en.wikipedia.org/wiki/USB>.
- Agrawal, Prathima, et al., "A Testbed for Mobile Networked Computing," AT&T Bell Laboratories, Murray Hill, NJ.
- Annamalai et al., "Emerging High-Speed Local-Area Networks and Wide-Area Networks," Proceedings, SPIE (International Society for Optical Engineering), vol. 2608, Oct. 24-26, 1995 (Philadelphia, PA).
- Apple Computer, Inc., Macintosh Quadra 700, Developer Technical Publications (1991).
- Apple Computer, Inc., Chapter 1, "Hardware," Macintosh PowerBook 160 and Macintosh PowerBook 180 (2000).
- Apple Computer, Inc., excerpt, "Devices," *Inside Macintosh* (1994).
- Apple Technical Library, Chapters 1 and 2, "Introduction to File Management" and "File Manager," *Inside Macintosh* (1992).
- Bowen, Jonathan, "A User-Friendly Interface Adapter" Computing Laboratory, Oxford University (Oxford, UK).
- Business Wire, "HP Receives Industry's First indows 95 Flatbed-Scanner Certification; HP ScanJet 4c and 4p Scanners Now Provide Easy Installation," Published Nov. 11, 1996.
- Casio, Owner's Manual for QV-10 B liquid crystal digital camera.
- Chan et al. "A Mega-Pixel Resolution PC Digital Still Camera," *SPIE*, 2654:164-172 (1996).
- Chapter 6, "Power Manager Reference".
- Clarke, P., "Two European Vendors Roll Peripheral ICs," *Electronic Engineering Times*, No. 928 (Nov. 18, 1996).
- Compaq, Intel, Microsoft, and NEC, "Universal Serial Bus Specification," Revision 1.1 (Sep. 23, 1998).
- Correll, K., and Ulichney, R., "The J300 Family of Video and Audio Adapters: Architecture and Hardware Design," *Digital Technical Journal*, vol. 7, No. 4 (1995).
- Davis, T., "The Path to a Custom Lab is Through a PC and an External Interface," *Research & Development* (Apr. 1985).
- DiNucci, Darcy, et al., excerpt, "SCSI ID," *Macintosh Bible* (5<sup>th</sup> Edition) translated to Japanese (1995).
- Eastman Kodak User's Manual for "Kodak Professional DCS 200 Digital Camera" (1993).
- Eastman Kodak User's Manual for EOS DCS 1, EOS DCS 3 and EOS DCS 5 digital cameras (1997).
- Excerpt of chapter 6, Macintosh "SCSI ID" (1994).
- Gadre, D., "Using the Parallel Adapter as a Host Interface Port: New Uses for Old Tools," *Dr. Dobbs' Journal* (Apr. 1996).
- Gallagher, Paul, "A MegaPixel Camera With SCSI Interface" (International Robots and Vision Automation Conference, May 9-11, 1995, Detroit, MI).
- Gallant, John, "Advancing the Art of Industrial Video imaging: CCD Cameras and Frame Grabbers," EDN Access, <http://www.edn.com/archives/1996/011896/> <<http://www.edn.com/archives/%201996%20011896%20df2.htm>.
- Heiman, E., "Maximize Computer Storage with an IPI Controller: Integrate a High Data-Transfer Rate Disk Controller Into Your Computer System" (Apr. 13, 1989).
- HighBeam Research, "1997 Technology Forecast," Published in Business New on Jan. 6, 1997.
- Himowitz, M. J., "Digital Watching/Infotech/Technology Monitor," *Time, Inc.* (Feb. 17, 1997).
- Hitoshi et al., "High Definition Image Capturing Camera HC-1000," vol. 17, No. 16 (Mar. 4, 1993).
- Hoffman, Gary, "A/V Digital Interface of Choice," IEEE 1394 (Jan. 1996).
- HP Photosmart Digital Camera—How the HP PhotoSmart Digital Camera Works.
- HP PhotoSmart Digital Camera—Product Overview.
- HP PhotoSmart Digital Camera—Product Specifications (Model No. C5340A).
- HP PhotoSmart Digital Camera C20/C30/C200 Series—TWIN Technology Overview.
- HP website, HP Photosmart digital camera—Accessories, Parts, Supplies, and Manuals.
- HP website, HP Photosmart Digital Camera—What Ships in the Box. hpNOW, "PhotoSmart System" (Mar. 18, 1997).
- Isoyama et al., "ISDN Basic Interface for Sumistation," Sumitomo Electric Technical Review, No. 31 (Jan. 1991).
- Jones, Douglas W., "Disk Interfaces," University of Iowa, Department of Computer Science (Fall 1996).
- Kleiman, S., Vnodes: An Architecture for Multiple file SystemTypes in Sun UNIX (Sun Microsystems).
- Kodak DCS-Digital Still SLR camera, "A brief info on Kodak DCS-Series Digital Still SLR cameras" (Oct. 30, 2006).
- Kodak TIB4234, DCS 200 AC Power Adapter, Kodak Technical Information Bulletin (Jun. 2000).
- Kodak User's Guide DC25 Digital Camera.
- Lang, Michael, "Optical Server Uses Network Protocols for Plug-and-Play Integration," *Computer Technology Review* (Special Fall Issue, Dec. 1993).
- Moore, D.J., "Multimedia Presentation Development Using the Audio Visual Connection," *IBM Systems Journal*, vol. 29, No. 4 (1990).
- Müller, H., et al., "The CHI, a New Fastburst Interface and Processor," *IEEE Transaction on Nuclear Science*, vol. 7, No. 2.
- Nikon F-801s—N8008s Repair Manual, Nikon Corporation.
- Nikon N8008s AF Instruction Manual.
- Note, S., et al. "Rapid prototyping of DSP systems: requirements and solutions," pp. 88-96, 1074-6005/95 © 1995 IEEE.
- Oda, K., et al., "The Development of Digital Still Camera Using 1.3M-Pixel VT-CCD Image Sensor," ITE Technical Report, vol. 19, No. 60 (Nov. 15, 1995).
- Okuda, K., chapter from book, "MacRecorder," translated to Japanese (Jul. 20, 1992).
- Pournelle, A., "JetSend Technology Allows Device Connectivity With No Servers, Drivers, or Code—Company Business and Marketing," *Computer Technology Review* (Jul. 1999).
- Quinnell, R., "The Mighty Morphin' PCI Bus," *EDN* (Apr. 25, 1996).
- Rieg, E., "Improved design avoids bottlenecks," *Elektronik*, Sep. 29, 1989; 38(20): pp. 52-56, (German) English translation.
- Sawert, B., "The Advanced SCSI Programming Interface," *Dr. Dobbs Journal* (Mar. 1994).
- Schmidt, F. "SCSI-Bus und IDE-Schnittstelle," Sect. 3.5-3.17.3, pp. 174-316.
- Schmidt, F. "The SCSI Bus and IDE Interface—Protocols, Applications and Programming," translated (English) from the German edition SCSI-Bus und IDE-Schnittstelle, Addison-Wesley (Deutschland) GmbH.
- Section 5, "Using the DCS 200 Camera with a PC," of Kodak User's Manual.
- Section 8, "Reference-Kodak Driver for Aldus PhotoStyler Software," of Kodak User's Manual.
- Sheppard et al., "Engineering Advances: New Opportunities for Biomedical Engineers," Proceedings of the 16<sup>th</sup> Annual International Conference of the IEEE Engineering in Medicine and Biology Society, vol. 16 (Nov. 3-6, 1994).
- Simpson, R. W., "High Performance, Dual Speed CCD Camera System for Scientific Imaging," *SPIE*, vol. 2654 (Jan. 31, 1996).
- Slater, M., "Universal Serial Bus to Simplify PC/IO: New Interface to Service Keyboards, Mice, Telecom, and More," *Microprocessor Report*, vol. 9, No. 5 (Apr. 17, 1995).
- Sony Semiconductor, "New Interface of Digital Network Age," IEEE 1394.
- Spragens, J., "Kodak DCS 420 Takes Photographers Out of the Dark-room and Onto Disk," *InfoWorld* (Feb. 13, 1995).
- SystemSoft® Corporation and Intel Corporation®, "Universal Serial Bus Common Class Specification" (Dec. 16, 1997).
- Tatlow, M., et al. "New techniques for high-speed data acquisition," p. 39-49; *Electronic Engineering*, vol. 62, No. 765 (Sep. 1990).
- Universal Serial Bus Mass Storage Class; UFI Command Specification, Revision 1.0.



# Explore Litigation Insights

Docket Alarm provides insights to develop a more informed litigation strategy and the peace of mind of knowing you're on top of things.

## Real-Time Litigation Alerts



Keep your litigation team up-to-date with **real-time alerts** and advanced team management tools built for the enterprise, all while greatly reducing PACER spend.

Our comprehensive service means we can handle Federal, State, and Administrative courts across the country.

## Advanced Docket Research



With over 230 million records, Docket Alarm's cloud-native docket research platform finds what other services can't. Coverage includes Federal, State, plus PTAB, TTAB, ITC and NLRB decisions, all in one place.

Identify arguments that have been successful in the past with full text, pinpoint searching. Link to case law cited within any court document via Fastcase.

## Analytics At Your Fingertips



Learn what happened the last time a particular judge, opposing counsel or company faced cases similar to yours.

Advanced out-of-the-box PTAB and TTAB analytics are always at your fingertips.

## API

Docket Alarm offers a powerful API (application programming interface) to developers that want to integrate case filings into their apps.

## LAW FIRMS

Build custom dashboards for your attorneys and clients with live data direct from the court.

Automate many repetitive legal tasks like conflict checks, document management, and marketing.

## FINANCIAL INSTITUTIONS

Litigation and bankruptcy checks for companies and debtors.

## E-DISCOVERY AND LEGAL VENDORS

Sync your system to PACER to automate legal marketing.