



US005592256A

# United States Patent [19]

[11] **Patent Number:** 5,592,256

**Muramatsu**

[45] **Date of Patent:** Jan. 7, 1997

[54] **PHOTOMETRY DEVICE FOR A CAMERA**

4,797,942	1/1989	Burt .....	382/41
5,187,754	2/1993	Currin et al. ....	382/54
5,233,517	8/1993	Jindra .....	364/413.13
5,249,015	9/1993	Takagi et al. .	
5,266,984	11/1993	Muramatsu et al. .	
5,270,767	12/1993	Hamada et al. ....	354/430
5,319,416	6/1994	Takagi .....	354/432

[75] Inventor: **Masaru Muramatsu**, Kawasaki, Japan

[73] Assignee: **Nikon Corporation**, Tokyo, Japan

[21] Appl. No.: **654,998**

[22] Filed: **May 29, 1996**

*Primary Examiner*—Safet Metjahic  
*Assistant Examiner*—D. P. Malloy

### Related U.S. Application Data

[63] Continuation of Ser. No. 246,424, May 20, 1994, abandoned.

### Foreign Application Priority Data

Jun. 8, 1993 [JP] Japan ..... 5-163919

[51] **Int. Cl.<sup>6</sup>** ..... **G03B 7/08**

[52] **U.S. Cl.** ..... **396/225; 348/362; 348/366; 396/234**

[58] **Field of Search** ..... **354/430, 432; 348/362, 366**

### References Cited

#### U.S. PATENT DOCUMENTS

4,395,099 7/1983 Terasita .  
4,476,383 10/1984 Fukuhara et al. .

### [57] ABSTRACT

A photometric device for use in a camera includes, but is not limited to, a segmented brightness measuring unit which segments a photographic scene of a camera into multiple areas and which outputs corresponding multiple photometric values. A spectral analysis unit performs spectral analysis of the spatial frequency of a photographic subject using the corresponding multiple photometric values output by the segmented brightness measuring unit. Also, a photometric computation unit computes photometric values based on the spectral pattern of the photographic subject output by the spectral analysis unit. The spectral analysis unit may be disposed within the photometric device, or may be located elsewhere in a camera's body.

**20 Claims, 4 Drawing Sheets**

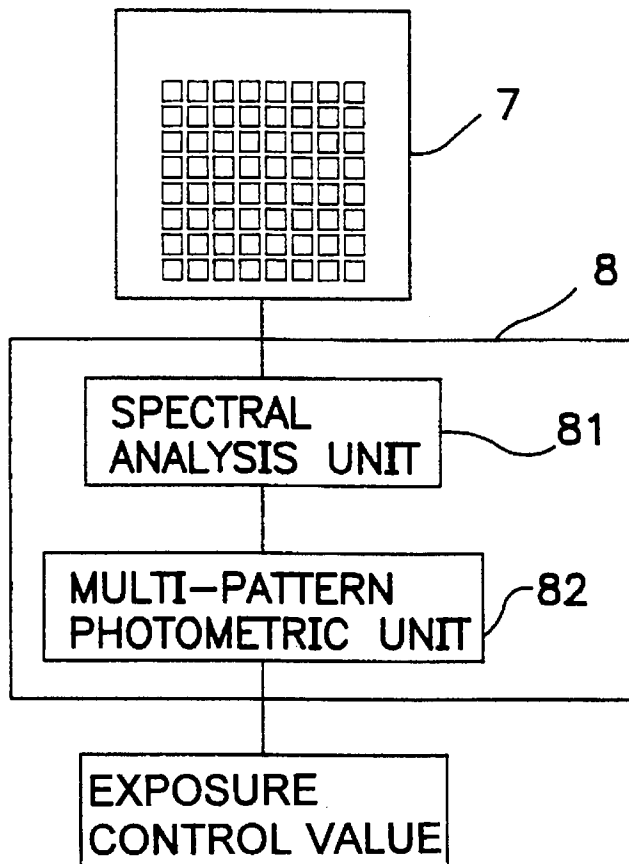

FIG. 1

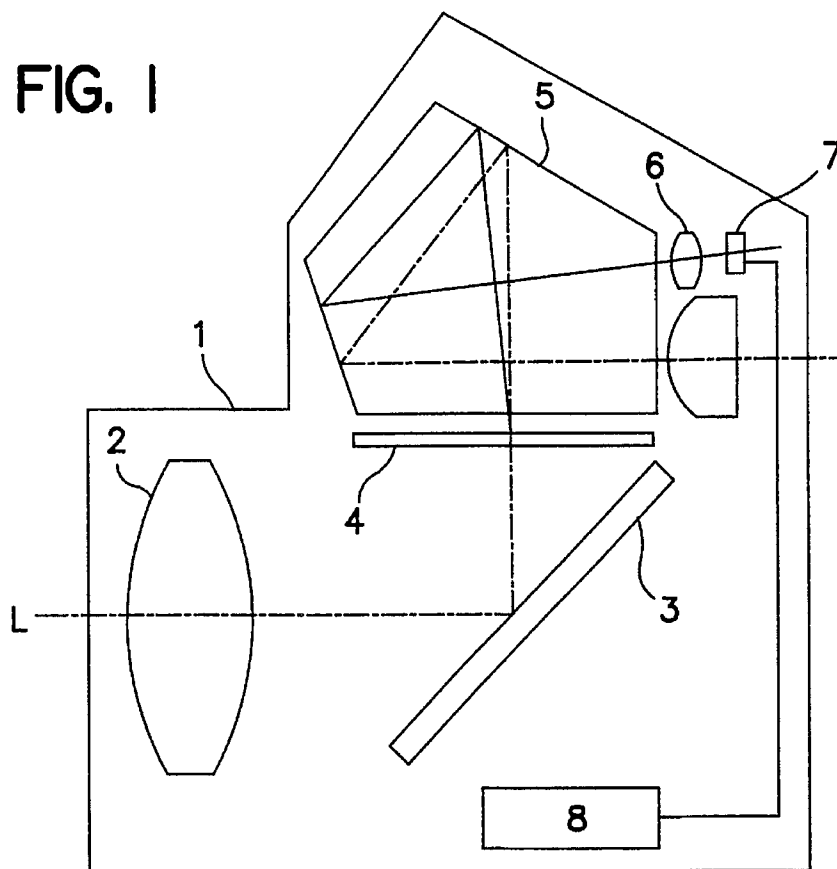

FIG. 2

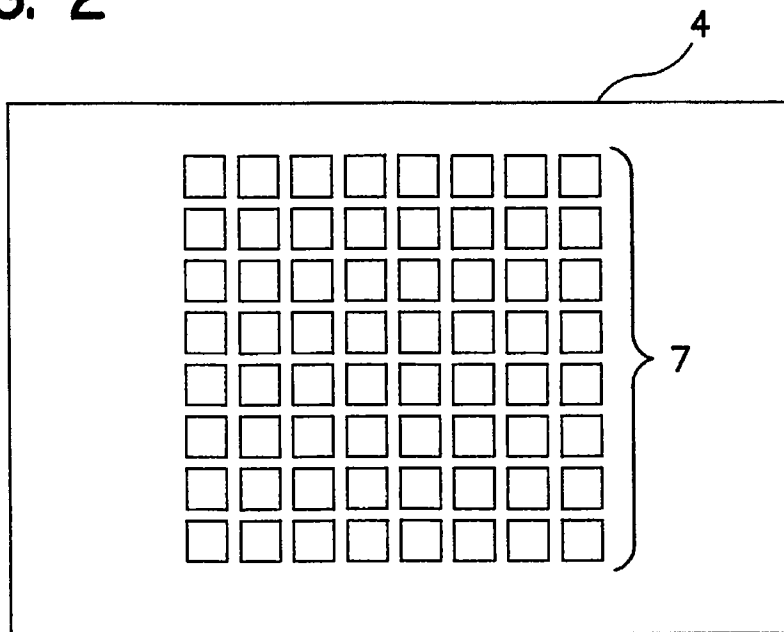

FIG. 3

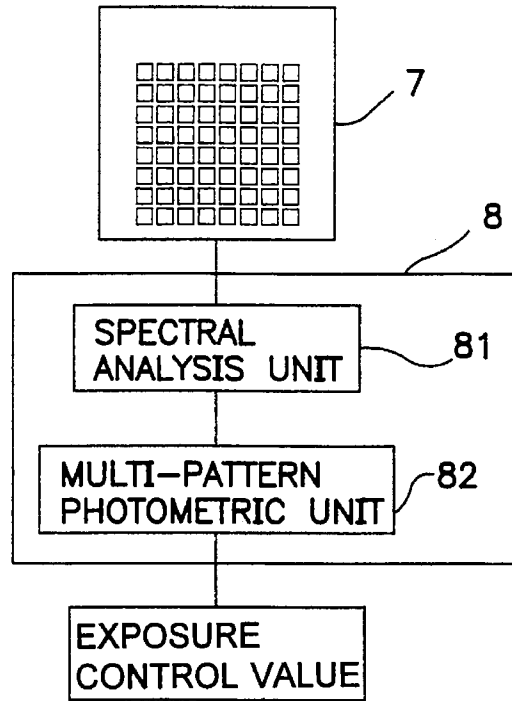

FIG. 4

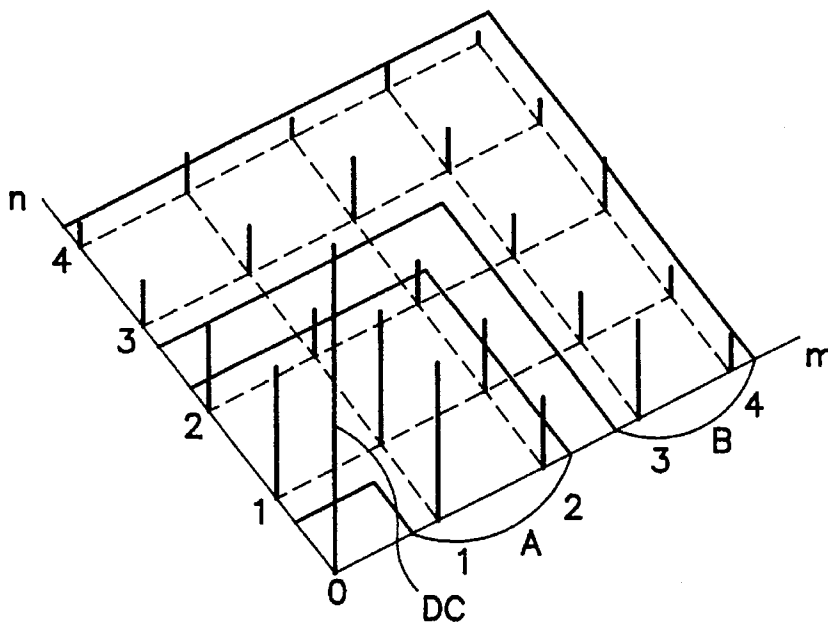

FIG. 5

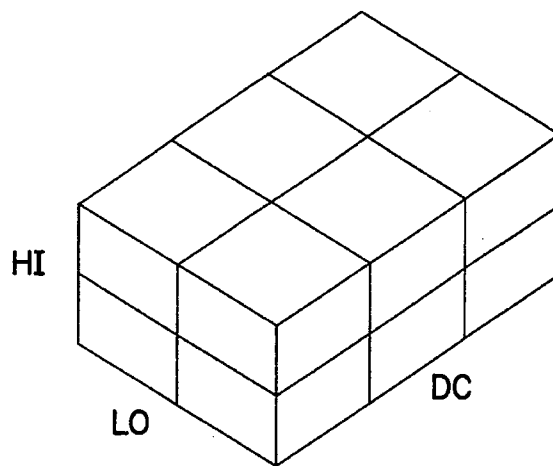

FIG. 6

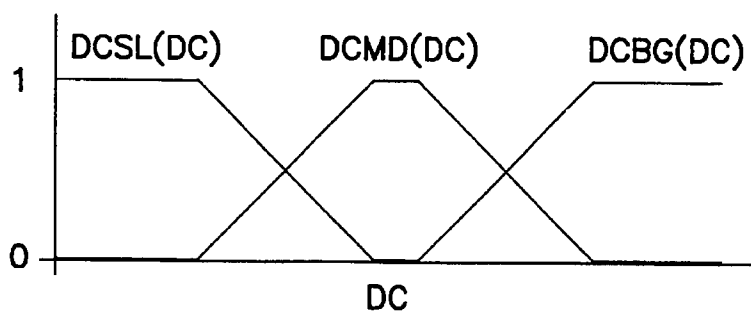

FIG. 7

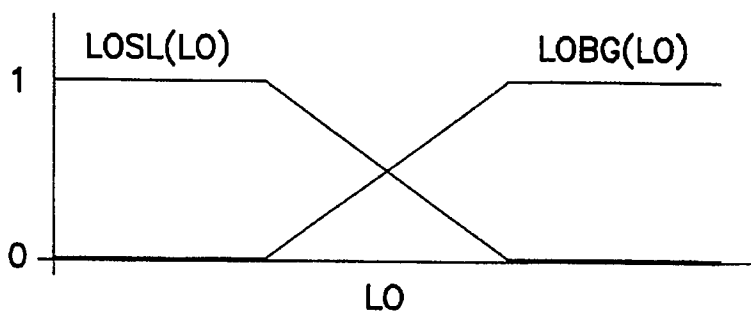
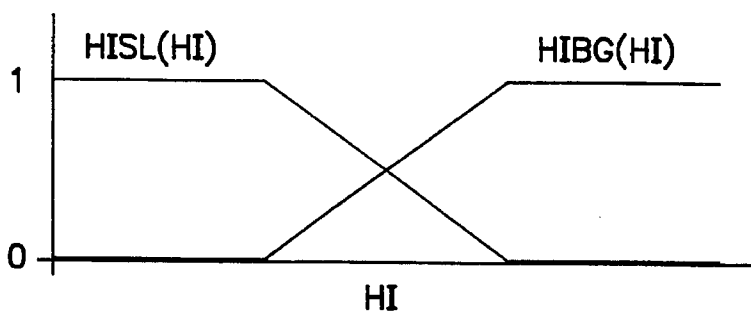

FIG. 8



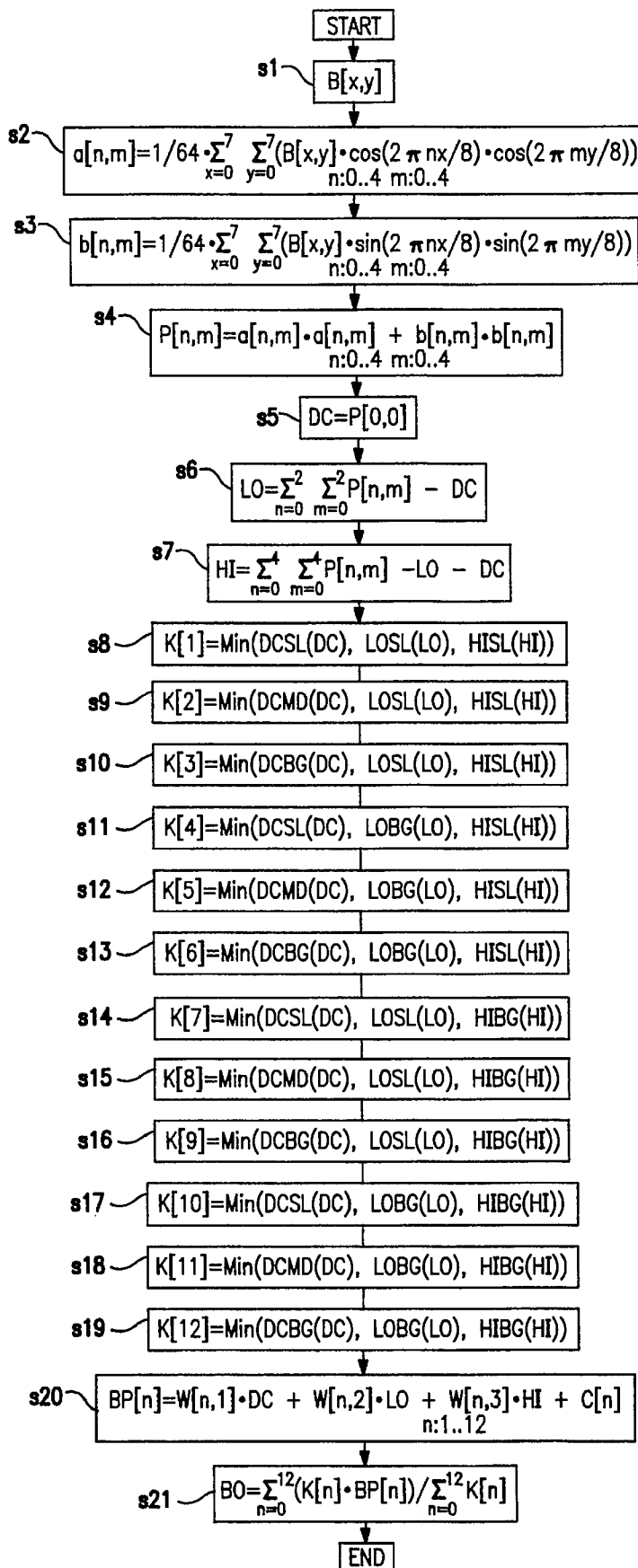

FIG. 9

# Explore Litigation Insights

Docket Alarm provides insights to develop a more informed litigation strategy and the peace of mind of knowing you're on top of things.

## Real-Time Litigation Alerts



Keep your litigation team up-to-date with **real-time alerts** and advanced team management tools built for the enterprise, all while greatly reducing PACER spend.

Our comprehensive service means we can handle Federal, State, and Administrative courts across the country.

## Advanced Docket Research



With over 230 million records, Docket Alarm's cloud-native docket research platform finds what other services can't. Coverage includes Federal, State, plus PTAB, TTAB, ITC and NLRB decisions, all in one place.

Identify arguments that have been successful in the past with full text, pinpoint searching. Link to case law cited within any court document via Fastcase.

## Analytics At Your Fingertips



Learn what happened the last time a particular judge, opposing counsel or company faced cases similar to yours.

Advanced out-of-the-box PTAB and TTAB analytics are always at your fingertips.

## API

Docket Alarm offers a powerful API (application programming interface) to developers that want to integrate case filings into their apps.

## LAW FIRMS

Build custom dashboards for your attorneys and clients with live data direct from the court.

Automate many repetitive legal tasks like conflict checks, document management, and marketing.

## FINANCIAL INSTITUTIONS

Litigation and bankruptcy checks for companies and debtors.

## E-DISCOVERY AND LEGAL VENDORS

Sync your system to PACER to automate legal marketing.