



US008504746B2

(12) **United States Patent**
Tasler

(10) **Patent No.:** **US 8,504,746 B2**
(45) **Date of Patent:** ***Aug. 6, 2013**

(54) **ANALOG DATA GENERATING AND PROCESSING DEVICE FOR USE WITH A PERSONAL COMPUTER**

(58) **Field of Classification Search**
USPC 710/15, 63, 69
See application file for complete search history.

(75) **Inventor:** Michael L. Tasler, Würzburg (DE)

(56) **References Cited**

(73) **Assignee:** Papst Licensing GmbH & Co. KG, St. Georgen (DE)

U.S. PATENT DOCUMENTS

3,714,635 A 1/1973 Hamilton et al.
3,805,245 A 4/1974 Brooks et al.

(*) **Notice:** Subject to any disclaimer, the term of this patent is extended or adjusted under 35 U.S.C. 154(b) by 0 days.

(Continued)

This patent is subject to a terminal disclaimer.

FOREIGN PATENT DOCUMENTS

DE 3624373 A1 1/1987
DE 88 G 3559 3/1989

(Continued)

(21) **Appl. No.:** 12/891,443

OTHER PUBLICATIONS

(22) **Filed:** Sep. 27, 2010

Ristelhueber: "Plug and play is almost here," May 1994, Electronic Business Buyer, v20, pp. 1-3.*

(65) **Prior Publication Data**

(Continued)

US 2011/0131353 A1 Jun. 2, 2011

Related U.S. Application Data

(63) Continuation of application No. 11/928,283, filed on Oct. 30, 2007, now abandoned, which is a continuation of application No. 11/467,073, filed on Aug. 24, 2006, and a continuation of application No. 11/078,778, filed on Mar. 11, 2005, now abandoned, and a continuation of application No. 10/219,105, filed on Aug. 15, 2002, now Pat. No. 6,895,449, and a continuation of application No. 09/331,002, filed on Jun. 14, 1999, now Pat. No. 6,470,399.

Primary Examiner — Chun-Kuan Lee

(74) *Attorney, Agent, or Firm* — Husch Blackwell LLP

(30) **Foreign Application Priority Data**

(57) **ABSTRACT**

Mar. 4, 1997 (DE) 197 08 755
Mar. 3, 1998 (WO) PCT/EP98/01187

An interface device (10) provides fast data communication between a host device with input/output interfaces and a data transmit/receive device, wherein the interface device (10) comprises a processor means (13), a memory means (14), a first connecting device (12) for interfacing the host device with the interface device, and a second connecting device (15) for interfacing the interface device (10) with the data transmit/receive device. The interface device (10) is configured by the processor means (13) and the memory means (14) in such a way that, when receiving an inquiry from the host device via the first connecting device (12) as to the type of a device attached to the host device, regardless of the type of the data transmit/receive device, the interface device sends a signal to the host device via the first connecting device (12) which signals to the host device that it is communicating with an input/output device.

(51) **Int. Cl.**
G06F 3/00 (2006.01)
G06F 13/12 (2006.01)
G06F 13/38 (2006.01)

(52) **U.S. Cl.**
USPC 710/69; 710/15; 710/63

35 Claims, 2 Drawing Sheets

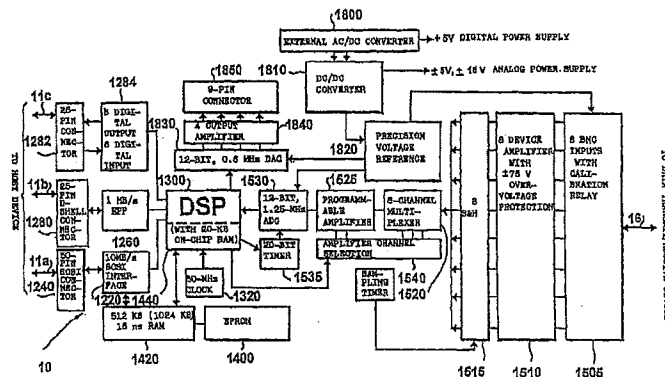

U.S. PATENT DOCUMENTS

3,976,979 A	8/1976	Parkinson et al.	5,640,204 A	6/1997	Tsutsui
4,041,473 A	8/1977	Bardotti et al.	5,663,901 A	9/1997	Wallace et al.
4,420,773 A	12/1983	Toyoda et al.	5,668,976 A	9/1997	Zook
4,466,573 A	8/1984	Camboulives et al.	5,689,710 A	11/1997	Stanley et al.
4,509,113 A	4/1985	Heath	5,692,159 A	11/1997	Shand
4,642,759 A	2/1987	Foster	5,696,970 A	12/1997	Sandage et al.
4,652,928 A *	3/1987	Endo et al. 348/219.1	5,703,584 A	12/1997	Hill
4,680,732 A	7/1987	DiCenzo	5,712,682 A	1/1998	Hannah
4,787,027 A	11/1988	Prugh et al.	5,724,155 A	3/1998	Saito
4,888,680 A	12/1989	Sander et al.	5,724,574 A	3/1998	Stratigos et al.
4,896,262 A	1/1990	Wayama et al.	5,742,934 A *	4/1998	Shinohara 711/103
4,901,275 A	2/1990	Hardie et al.	5,748,924 A	5/1998	Llorens et al.
4,972,470 A	11/1990	Farago	5,754,227 A	5/1998	Fukuoka
5,014,186 A	5/1991	Chisholm	5,764,546 A	6/1998	Bryant et al.
5,034,598 A	7/1991	Poland	5,765,027 A	6/1998	Wang et al.
5,070,474 A	12/1991	Tuma et al.	5,778,205 A	7/1998	Orimoto
5,088,033 A	2/1992	Binkley et al.	5,778,384 A	7/1998	Provino et al.
5,129,036 A	7/1992	Dean et al.	5,784,581 A	7/1998	Hannah
5,131,089 A	7/1992	Cole	5,790,193 A	8/1998	Ohmori
5,197,128 A	3/1993	Campbell et al.	5,794,032 A	8/1998	Leyda
5,214,761 A	5/1993	Barrett et al.	5,802,325 A	9/1998	Le Roux
5,214,785 A	5/1993	Fairweather	5,802,385 A	9/1998	Densham et al.
5,226,168 A	7/1993	Kobayashi et al.	5,806,072 A	9/1998	Kuba et al.
5,230,065 A	7/1993	Curley et al.	5,812,879 A	9/1998	Moro
5,231,501 A	7/1993	Sakai	5,815,201 A	9/1998	Hashimoto et al.
5,275,327 A	1/1994	Watkins et al.	5,822,614 A	10/1998	Kenton et al.
5,291,584 A	3/1994	Challa et al.	5,841,471 A	11/1998	Endsley et al.
5,296,611 A	3/1994	Solladie et al.	5,844,961 A	12/1998	McEvoy et al.
5,297,124 A	3/1994	Plotkin et al.	5,845,094 A	12/1998	Beauchamp et al.
5,303,326 A	4/1994	Dean et al.	5,848,420 A	12/1998	Xu
5,369,484 A	11/1994	Haugen	5,854,905 A	12/1998	Garney
5,371,885 A	12/1994	Letwin	5,854,945 A	12/1998	Criscito et al.
5,379,382 A	1/1995	Work et al.	5,854,949 A	12/1998	Furukawa et al.
5,386,518 A	1/1995	Reagle et al.	5,871,368 A	2/1999	Erdner et al.
5,402,170 A	3/1995	Parulski et al.	5,875,415 A	2/1999	Lieb et al.
5,428,357 A	6/1995	Haab et al.	5,877,975 A	3/1999	Jigour et al.
5,430,855 A	7/1995	Walsh et al.	5,878,248 A	3/1999	Tehrani et al.
5,440,699 A	8/1995	Farrand et al.	5,881,366 A	3/1999	Bodenmann et al.
5,444,644 A	8/1995	Divjak	5,884,103 A	3/1999	Terho et al.
5,457,784 A	10/1995	Wells et al.	5,892,939 A	4/1999	Call et al.
5,457,785 A	10/1995	Kikinis et al.	5,914,748 A	6/1999	Parulski et al.
5,463,772 A	10/1995	Thompson et al.	5,915,106 A	6/1999	Ard
5,465,106 A	11/1995	Keech et al.	5,917,545 A	6/1999	Kowno et al.
5,475,441 A	12/1995	Parulski et al.	5,920,709 A	7/1999	Hartung et al.
5,479,206 A	12/1995	Ueno et al.	5,923,193 A	7/1999	Bloch et al.
5,487,154 A	1/1996	Gunji	5,926,208 A	7/1999	Noonen et al.
5,493,335 A	2/1996	Parulski et al.	5,928,347 A	7/1999	Jones
5,499,378 A	3/1996	McNeill, Jr. et al.	5,929,903 A	7/1999	Kiesow
5,506,617 A	4/1996	Parulski et al.	5,930,480 A	7/1999	Staats
5,506,692 A	4/1996	Murata	5,935,224 A	8/1999	Svancarek et al.
5,508,821 A	4/1996	Murata	5,937,423 A	8/1999	Robinson
5,510,774 A	4/1996	Phillips	5,946,386 A	8/1999	Rogers et al.
5,515,474 A	5/1996	Deacon et al.	5,948,091 A	9/1999	Kerigan et al.
5,524,047 A	6/1996	Brown et al.	5,969,750 A	10/1999	Hsieh et al.
5,528,765 A	6/1996	Milligan	5,974,161 A	10/1999	York
5,530,858 A	6/1996	Stanley et al.	5,991,530 A	11/1999	Okada et al.
5,532,825 A	7/1996	Lim et al.	5,995,080 A	11/1999	Biro et al.
5,537,597 A	7/1996	Sandage	6,005,613 A	12/1999	Endsley et al.
5,539,535 A	7/1996	Aizawa et al.	6,012,113 A	1/2000	Tuckner
5,548,782 A	8/1996	Michael et al.	6,014,430 A	1/2000	Gosney et al.
5,548,783 A	8/1996	Jones et al.	6,023,292 A	2/2000	Wakui
5,570,146 A	10/1996	Collette	6,026,217 A	2/2000	Adiletta
5,574,859 A	11/1996	Yeh	6,029,215 A	2/2000	Watts, Jr. et al.
5,576,757 A *	11/1996	Roberts et al. 348/220.1	6,067,584 A	5/2000	Hayles et al.
5,579,529 A	11/1996	Terrell et al.	6,081,856 A	6/2000	Comer
5,581,741 A	12/1996	Clark et al.	6,086,430 A	7/2000	Amoni et al.
5,596,628 A	1/1997	Klein	6,088,532 A	7/2000	Yamamoto et al.
5,614,344 A	3/1997	Kawakami et al.	6,094,219 A	7/2000	Roberts et al.
5,614,670 A	3/1997	Nazarian et al.	6,098,116 A	8/2000	Nixon et al.
5,614,948 A	3/1997	Hannah	6,101,276 A	8/2000	Adiletta et al.
5,619,659 A	4/1997	Kikinis et al.	6,104,430 A	8/2000	Fukuoka
5,625,800 A	4/1997	Brayton et al.	6,111,604 A *	8/2000	Hashimoto et al. 348/220.1
5,625,840 A	4/1997	Numata et al.	6,119,180 A	9/2000	Terho et al.
5,628,030 A	5/1997	Tuckner	6,131,125 A	10/2000	Rostoker et al.
5,630,164 A	5/1997	Williams et al.	6,147,703 A	11/2000	Miller et al.
5,634,075 A *	5/1997	Smith et al. 710/9	6,149,316 A	11/2000	Harari et al.
5,638,299 A	6/1997	Miller	6,163,344 A	12/2000	Kawamura et al.
5,639,606 A	6/1997	Willey	6,182,145 B1	1/2001	Schuman et al.
			6,188,675 B1	2/2001	Casper et al.

6,256,319	B1	7/2001	Apgar et al.	
6,256,452	B1	7/2001	Yamamoto	
6,260,102	B1	7/2001	Robinson	
6,278,492	B1*	8/2001	Nakamura	348/441
6,286,073	B1	9/2001	Vegter	
6,292,589	B1	9/2001	Chow et al.	
6,298,388	B1	10/2001	Taguchi	
6,344,875	B1	2/2002	Hashimoto et al.	
6,424,809	B1	7/2002	Yamamoto et al.	
6,441,854	B2	8/2002	Fellagara et al.	
6,470,399	B1	10/2002	Tasler	
6,654,050	B2	11/2003	Karube et al.	
6,670,985	B2	12/2003	Karube et al.	
6,895,449	B2	5/2005	Tasler	
7,046,276	B2	5/2006	Hashimoto et al.	
2001/0050711	A1	12/2001	Karube et al.	

FOREIGN PATENT DOCUMENTS

DE	390 332	B	4/1990
DE	41 37 928	A1	5/1992
DE	296 07 724	U1	4/1996
DE	195 28 889	A1	2/1997
EP	0 03 044		4/1984
EP	0 259 786	A1	9/1987
EP	0 391 157	A2	3/1990
EP	0 685 799	A1	5/1995
EP	0 705 037	A2	3/1996
JP	53145535	A	12/1978
JP	61034652	A	2/1986
JP	61060164	A	3/1986
JP	63-133204		6/1988
JP	01303554	A	7/1989
JP	01293404	A	11/1989
JP	02-051727		2/1990
JP	H2-51727		2/1990
JP	02114351	A	4/1990
JP	04-133152		5/1992
JP	04-213715		8/1992
JP	04-309156		10/1992
JP	Hei 4-309156		10/1992
JP	06-052087		2/1994
JP	06-067815		3/1994
JP	06-83917		3/1994
JP	06-090423		3/1994
JP	H6-83917		3/1994
JP	06-301607		10/1994
JP	6-301607		10/1994
JP	07-044290		2/1995
JP	07-177406		7/1995
JP	Hei7-177406		7/1995
JP	07-202982		8/1995
JP	08-110883		4/1996
JP	08-130702		5/1996
JP	H8-130702		5/1996
JP	08-191375		7/1996
JP	8-191410		7/1996
JP	08-191412		7/1996
JP	08-223341		8/1996
JP	H08-223341		8/1996
JP	08-328990		12/1996
JP	H8-328990		12/1996
JP	09016506	A	1/1997
JP	09-091237		4/1997
JP	03-246654		11/1997
JP	10-177535		6/1998
WO	WO 94/19746		9/1994

OTHER PUBLICATIONS

Installing DeskLab, Gradient Desklab 216 Misc. Matls (68 pgs).
Desklab 216 User Manual, Gradient Desklab User's Manual: 1992 (225 pgs).
14-Bit, 2 MHz A-to-D SCSI substation for the Most Demanding Data Acquisition Applications, Analogic the World Resource for Precision Signal Technology, Bulletin No. 16-100452 Rev 0 3/92 xM, 1992 (4 pgs).
16-Bit Digital-to-Analog Converter Subsystem Attaches to Host SCSI Port, Analogic the World Resource for Precision Signal Technology, Bulletin No. 16-100xxx Rev xx/92 xM, 1992, (3 pgs).

SCSI Real-Time Video Frame Grabber 8-Bit Monochrome with up to 8 Mbytes Memory, Analogic the World Resource for Precision Signal Technology, Bulletin No. 16-100424 Rev 2 2/92 2M, 1992 (4 pgs).
16 & 18-Bit, A/D Converters for Digital Audio, Crystal Semiconductor Corporation, Mar. '92, pp. 5-23.
 Short, Kenneth L., *Microprocessors and Programmed Logic*, Library of Congress Cataloging in Publication Data, Prentice-Hall, Inc., 1981.
 Francis et al., Principles of interfacing computers to medical equipment, Bailliere's Clinical Obstetrics and Gynaecology, vol. 4, No. 4, Dec. 1990, ISBN 0-7020-1479-6, pp. 787-795.
Programmer's Technical Reference for MSDOS and the IBM PC, http://www.o3one.org/hwdocs/bios_doc/dorsef22.html, pp. 1-213; Dave Williams, 1987, 1992.
 Ridge, Peter M., *The Book of SCSI a Guide for Adventurers*, Library of Congress 1995 (436 pgs).
Universal Lab Interface User's Manual, Vernier Software & Technology, pp. 1-40.
Universal Lab Interface Software Developer's Guide, Vernier Software & Technology, pp. 1-68.
 Lee et al., *A standardized Approach for Transducer Interfacing: Implementing IEEE-P1451 Smart Transducer Interface Draft Standards*, U.S. Department of Commerce, Oct. 1996 (34 pgs).
 Duncan, Ray, *Advanced MSDOS the Microsoft guide for Assembly Language and C programmers*. Library of Congress Cataloging in Publication Data, Microsoft Press, 1986.
 Johnson, Robert N., *Building Plug-and-Play Networked Smart Transducers*, Sensors Magazine, Oct. 1997, p. 1-19.
 Bove et al., *Cheops: A Reconfigurable Data-Flow System for Video Processing*, IEEE Transactions on Circuits and Systems for Video Technology, vol. 5, No. 2, Apr. 1995, pp. 140-149.
 Bove et al., *Cheops: A Reconfigurable Data-Flow System for Video Processing*, IEEE Transactions on Circuits and Systems for Video Technology, Apr. 5, 1995.
Common Communication Interfaces for Networked Smart Sensors and Actuators, Sensors, Sep. 1995, pp. 14-23.
 Conway et al., *IEEE 1451.2: An Interpretation and Example Implementation*, IEEE Xplore, 2000, pp. 535-541.
 Miao, T., *IEEE 1451.2, A Network Independent Standard for Smart Transducers*, IEEE Xplore, 1998, pp. 1-4.
 Woods et al., *IEEE-P1451.2 Smart Transducer Interface Module*, pp. 25-39.
 Spoelder, et al., *Real-time data-acquisition within a standard UNIX environment: Advantages of a divide-and-conquer strategy*, Instrumentation and Measurement Technology Conference, 1993, IMTC/93 Conference Record., IEEE, pp. 1-4.
 Young et al., *Real-time Visualisation of Cardiac Arrhythmias*, IEEE Xplore, pp. 1244-1245.
 Fischer et al., *The PICmicro MCU as an IEEE 1451.2 Compatible Smart Transducer Interface Module (STIM)*, Microchip Technology, Inc. 2000, pp. 1-63.
 Lee, Kang, *The Proposed Smart Transducer Interface Standard*, IEEE Instrumentation and Measurement Technology Conference, 1998, pp. 129-135.
Smart Transducer Module, Telemonitor, Inc., Feb. 9, 2000.
 Gallagher, Paul K., *Vision Systems for Quality Control*, EG&G Teticon, ISBN# 0-7803-2639-3, pp. 381-387.
 Yu, Ross Anthony, *A Field Programmable Gate Array Based Stream Processor for the Cheops Imaging System*, Massachusetts Institute of Technology, 1996, pp. 82.
 Desklab, *SCSI data collection/analysis box*, <http://gbppr.dyndns.org/10pht/blackcrlw/hamradio/voicecom/dspfaq2.txt>, Sep. 1990, p. 1.
Applied Computer Science Group—Multimodal Human Computer Interaction (SF360), <http://aiweb.techfak.uni-bielefeld.de/files/old-site/projects-perceptionprototype/welcome.html>, 2010, pp. 1-2.
 Cole et al., *A Telephone Speech Database of Spelled and Spoken Names*, Center for Spoken Language Understanding, pp. 1-7.
 Muthusamy, Yeshwant Kumar, *A Segmental Approach to Automatic Language Identification*, A dissertation of the Oregon Graduate Institute of Science and Technology, 1993, pp. 1-309.
 Muthusamy, et al., *The OGI Multi-Language Telephone Speech Corpus*, Oregon Graduate Institute of Science and Technology, pp. 1-9.

- Kletzander, Arno, *Strange SCSI devices*, Studentische Hilfskraft Infromatikk Sammlung Erlangen, 1983, p. 1.
- 16-Bit Multimedia Audio Codex*, Crystal Semiconductor Corporation, 1993 pp. 1-53.
- Cole et al., *Telephone Speech Corpus Development At CSLU*, ICSLP-94, 1994, pp. 1-4.
- Cole, et al., *Corpus Development Activities at the center for Spoken Language Understanding*, Oregon Graduate Institute of Science and Technology, pp. 1-6.
- Document No. CM011691, p. 1.
- Spontaneous Speech Translation in Multimedia Environment*, 1995, pp. 1-216.
- Kluter et al., *Facts About the VerbMobil System*, pp. 6-65.
- The Telephone Connection, From a stationary Prototype to Telephone Translation Services*, pp. 3.
- Tri/4-Program Shippable Products Catalog*, Digital Equipment Corporation, 1992.
- Rubin et al., *HADES (Haskins Analysis Display and Experiment System)*, Haskins Laboratories, www.http://www.haskins.yale.edu/.
- Third Party Product Announcements*, The Florida SunFlash vol. 61, No. 2, 1994.
- Ching, et al., *Development of a Large Vocabulary Speech Database for Cantonese*, IEEE, 1997, pp. 1775-1778.
- Cooley et al., *DeskLab a SCSI-Based Real-Time Data Acquisition Solution for UNIX & VMS Workstations*, IEEE Signal Processing Magazine, vol. 9, No. 1, 1992.
- New Products*, Computer 1991, pp. 76-78.
- Kibrick et al., *CCD Data Acquisition Systems at Lick and Keck Observatories*, Astronomical Data Analysis Software and Systems II, ASP Conference Series, vol. 52, 1993, pp. 277-288.
- SAO/NASA ADS Astronomy Abstract Service*, CCD Data Acquisition Systems at Lick and Keck Observatories, 1993, pp. 1-2.
- Wooters, Charles Clayton; *Lexical Modeling in a Speaker Independent Speech Understanding System*, International Computer Science Institute, 1993.
- Saunders, John; *Real-time Discrimination of Broadcast Speech/Music*, Sanders, A Lockheed Martin Co., 1996 pp. 993-996.
- Personal Information of Philip E. Rubin, pp. 1-13.
- Rules for Automatic Grepeme-to-Allophone Transcription in Slovene.
- Woods, Sam P., *The IEEE-P1451 Transducer to Microprocessor Interface*, Sensors, Jun. 1996, p. 43-47.
- Tasler, Michael, *Design and Construction of a Universal Data Acquisition and Control System for Scanning Probe Microscopy*, The University of Texas At Austin, May 1996, (94 pgs).
- Universal Serial Bus (USB), *Devise Class Definition for Human Interface Devices (HID)*, 1997, USB Implementers' Forum.
- About the SCSI Manager*, http://developer.apple.com/documentation/mac/Devices/Devices-121.html, (6 pgs).
- Meter et al., *Derived Virtual Devices: A Secure Distributed File System Mechanism*, Fifth NASA Goddard Space Flight Center Conference on Mass Storage Systems and Technologies, Sep. 17, 1996 (16 pgs).
- User's manual, Kodak Professional DCS 200 Digital Camera*, Eastman Kodak Company, 1993 (140 pgs).
- Using the DCS 200 Camera with a PC*, (148 pgs).
- Kodak DC25 Digital camera, *User's Guide for camera and software*, (47 pgs).
- User's Manual, EOS-DCS 1, EOS.DCS 3, EOS.DCS 5 Digital Cameras*, Eastman Kodak Company, 1997, (314 pgs).
- Nikon Digital Camera E 100 User's Manual*, (50 pgs).
- Unno, et al., *32 MByte High Performance Solid State Disk*, Apr. 1996 (pp. 17-20).
- TRI/4 Progra, shippable Products Catalog*, Digital equipment Corporation, Oct. 1992.
- Polaroid Digital Camera PDC-2000*, User Guide for Macintosh or Windows publications, 1996, (133 pgs).
- General Flash Information (4 pgs).
- Photograph of camera (1 pg).
- Canon Becomes World's First Imaging Company to Offer SanDisk CompactFlash as Digital Film (3 pgs).
- Applications Overview (2 pgs).
- Press Release (2 pgs).
- Installation Guide (2 pgs).
- SanDisk Product Overview (3 pgs).
- SanDisk Questions and Answers (2 pgs).
- SanDisk PC Card User's Guide Introduction (30 pgs).
- SanDisk Application Note—Differences Between PC Card ATA and CompactFlash; 1996.
- SanDisk Corporation—ABC's of PCMCIA—General Inform non; pp. 1-7; dated Jul. 10, 2008.
- SanDisk Corporation—ABC's of PCMCIA—Technical Information; pp. 1-5; Jul. 10, 2008.
- SanDisk Corporation—Frequently Asks Questions About Digital Camera Memory Cards; p. 1-4; Jul. 10, 2008.
- SanDisk Corporation—Product Information; SanDisk Products Spect; Jul. 10, 2008.
- SanDisk Corporation—SanDisk IDE FlashDrive Specification; Interface—1.3" FlashDrive IDE & 1.8" FlashDrive IDE System Performance (Notes 1 & 2).
- SanDisk Corporation—SanDisk Introduces Flash Chipset—World's Smallest Embedded Solid-State ATA Data Storage System; Jul. 10, 2008.
- SanDisk Corporation—SanDisk PCMCIA Type II Flash Disk Specification 2MB through 85MB Capacities; Jul. 10, 2008.
- SanDisk Corporation—SanDisk to Supply Sony Electronics with Digital Flash Film for Sale With Sony's New DKC-1D1 Digital Camera; Contact: Nelson Chan; Jul. 10, 2008.
- SanDisk PCMCIA ATA FlashDisk User's Guide (3 pgs).
- SanDisk Memory Card—Digital Camera Compatibility List (5 pgs).
- SanDisk Introduces World's First 85MB Type II Flash Card; More Than Doubles Industry Capacity (3 pgs).
- SanDisk PCMCIA FlashDisks and Windows 95.
- SanDisk Type III FlashDisk (3 pgs).
- SanDisk CompactFlash Specification (3 pgs).
- SanDisk FlashChip Set Specification (3 pgs).
- SanDisk Products (8 pgs).
- SanDisk what's new Table of Contents (1 pg).
- IEEE Standard for a High Performance Serial Bus, 1996. 392 pp. (IEEE Std 1394-1995).
- Digidesign 882/20 I/O Audio Interface Installation Guide, 14 pp.
- Information Technology—Serial Bus Protocol 2 (SEP-2), T10 Project 1155D, Revision 4, May 19, 1998, 107 pp.
- An American National Standard, IEEE Standard for a Simple 32-Bit Backplane Bus: NuBus; 1998, 51 pp. (ANSI/IEEE 1196-1987).
- apple-history.com, Macintosh Quadra 650 (with NuBus Slots), Apple Computer, Inc., (produce introduced Oct. 1993) Nov. 29, 2005, 2pp.
- Wang, James www.sims.berkeley.edu Third Party NuBus AV (Audio-Video) Cards, 1993-1996 1 pg.
- Accredited Standards Committee X3, Information Technology, John Lohmeyer, X3T10/96-202r1, Agenda and Results of Meeting, X3T10 SCSI Working Group Meeting, Jul. 24, 1996 (6pp).
- Intel Corporation, Universal Host Controller Interface Design Guide (UHCI), Revision 1.1, Mar. 1996 (47 pp.).
- Twain Working Group Committee, Twain Toolkit Release V1.6, Twain Specification Release, Feb. 5, 1996 (367 pp.).
- Digidesign Website, www.digidesign.com, Tabular cross-reference "Pro Tools 4.0.10 NuBus Systems compatibility" as supported by Digidesign, Inc., Palo Alto, CA, 3 pp.
- Twain Working Group, www.twain.org, About Twain, 4 pp.
- Poumelle Alex, Jetsend Technology Allows Device connectivity with No Servers, Drivers, or Code, Computer Technology Review, Jul. 1999, vol. 19, Iss. 7, p. 22, 4 pp.
- Business Editors/Technology Writers, Salutation Port-of-Entry Software Lets Application Developers Control Network Peripherals from the Windows Desktop, Business Wire, Jul. 13, 1998, p. 1 (3 pp.).
- Wire Feed, HP Introduces JetSend for Pocket PC JetSend Solutions Now Compatible with Complete Range of Microsoft Windows CE- and Pocket PC-based Products, M2 Presswire, Apr. 26, 2000, p. 1 (3 pp.).
- Stedman, John HP and TROY Group Extend JetSend Protocol to Simplify Printing Over Networks and the Internet; JetSend Protocol Expands Cutting-edge Capabilities to Non-HP Printers, HP Deskjet Printers, Legacy HP LaserJet Printers and Future Products, M2 Presswire, Feb. 10, 2000, p. 1 (2 pp.).

- Business Editors, An Industry First, TROY Group's NetSend Makes Up to 9 Million HP Legacy Printers Internet-Ready, *Business Wire*, Nov. 16, 1999, p. 1(3 pp).
- Keele, Richard Designing Control Units that Interface Peripherals to the IBM I/O Channel, *Computer Technology Review*, Fall 1988; vol. 8, Iss. 13, p. 71 (1 page).
- Bursky, Dave Inter-System Communication Standard to Ease Clustered System Implementation, *Electronic Design*, Oct. 13, 1997, vol. 45, Iss. 22, p. 32 (3 pp.).
- Hadden, Thomas H., Tape Drive Without Backup Software? Wait No More, *Computer Technology Review Los Angeles*, Oct. 1995, vol. 15 Iss. 10, p. 34 (4 pp.).
- Ferelli, Mark, 12-inch WORM becomes the key to document image processing *Computer Technology Review Los Angeles*, Mar. 1994, vol. 14, Iss. 3, p. 1(3 pp.).
- Nelson, Andy Catching a Direct Bus. *InfoWorld*, Jun. 17, 1996, VOI. 18, Iss. 25, p. 129 (2 pp.).
- DeMonker, Judy 120 moves Into Clustering, Storage Arenas, *InfoWorld*, Dec. 9, 1996, vol. 18, Iss. 50, p. 37 (2 pp.).
- Krause, Reinhardt I/O Driver Spec to be Unveiled, *Electronic News*, Jan. 29, 1996, vol. 42, Iss. 2101, p. 1 (3 pp.).
- Microsoft Windows 95 README for MS-DOS Device Drivers, Aug. 1995, p. 1 (2 pp.).
- Lang, Michael Optical server uses network protocols for plug-and-play integration, *Computer Technology Review: Special Fall Issue*, Los Angeles, Dec. 1993, vol. 13, Iss. 15 p. 85 (6 pp.).
- Manual for Sony Digital Still Camera DSC-F1 (60 pages).
- Sony PC Connecting Kit—Operating Instructions (127 pages).
- Sony DSC-F1 Digital Still Camera (2 page).
- Manual for Canon EOS-DCS 3C Digital Camera (314 pages).
- Spec Sheet for Canon EOS-DCS 3C Digital Camera (2 pages).
- Spec Sheet for Canon PS600 Digital Camera (1 page).
- Information Regarding Olympus Camedia C-800L Digital Camera.
- Kodak DC20 Camera Manual (37 pages).
- Kodak Picture Easy Software (1 page).
- Kodak Picture Works Software (2 pages).
- Universal Serial Bus Specification, 1.0 Final Draft Revision, Nov. 13, 1995.
- Universal Serial Bus Specification, Revision 1.0, Jan. 15, 1996.
- Brochure for Nikon Coolpix 100 camera (English translation provided) (8 pages).
- Nikon Coolpix 100 Specification (4 pages).
- Technical Specs—QV-10A—QV Series—Cameras—Products—Casio (1 page).
- QV-Link Version 2.0 for Window (QVLINK-README.TXT) (5 pages).
- QV-10 OB Owner's Manual (Casio) (23 pages).
- Printouts made in 2007 from three web pages that concern commercial information about the Nikon Coolpix 100 camera. (English).
- A printout showing the file directory structure of the files contained in a CD-ROM that came with a used Nikon Coolpix 100 camera that was purchased in Europe in 2007. (English).
- A file called "COOL110S.PDF" that is stored in the CD-ROM that came with the used Nikon Coolpix camera that was purchased in Europe in 2007, the document contained in this file being entitled "Nikon Camara Digital Coolpix 100 Manual del Usuario." (Spanish).
- Pictures of a used Nikon Coolpix 100 camera that was purchased in the United States in 2007, one of the pictures showing the camera in a disassembled state.
- High Speed PC-based Data Acquisition Systems, Payne, Jeffrey R, Bradford A. Menz, et al.; 1995 IEEE, pp. 2140-2145.
- Implementing Remote Procedure Calls, Birrell, Andrew D. and Nelson, Bruce Jay; Xerox Palo Alto Research Center, *ACM Transactions on Computer Systems*, vol. 2, No. 1, Feb. 1984, pp. 39-59.
- QV-10 Digital Camera—News Release Nov. 14, 1994 (Feb. 1995 correction) Portable Image Information Equipment of Multimedia Age—Liquid Crystal Digital Camera of Compact Size (Jun. 7, 2007) CAP-020276 (internet web pages) 4 pages.
- It's the Most Effective, Cost-Sensitive Way to Publish Your Inventions; IBM Technical Disclosure Bulletin, vol. 38, No. 5, May 1995 (4 pages) CAP-020280.
- About.com: Inventors—History of the Digital Camera, Bellis, Mary, 2 pages.
- Wikipedia: Digital Camera (13 pages).
- A Brief Info on Kodak DCS-Series Digital Still SLR Cameras Part II—DCS-400 Series with Nikon N90(s)/F90(x) Body/Chassis (10 pages).
- Card Information Structure of Nikon Coolpix 100 Memory.
- Plug and Play SCSI Specification, Version 1.0, Mar. 30, 1994 (26 pages).
- Clarifications to the Plug and Play ISA Specification, Version 1.0a, Dec. 10, 1994 (Based on the results of the Plugfests held Jun. 6-8 and Oct. 11-13, 1994), (28 pages).
- Plug and Play ISA Specification, Version 1.0a, May 5, 1994 (71 pages).
- A Full-Featured Pentium® PCI-Based Notebook Computer; Author: Timothy F. Myers; *Hewlett-Packard Journal*; Dated Jun. 1996, Article 5; pp. 1-8.
- CD-ROM Drive F1197A for the HP OmniBook User's Guide; © Copyright Hewlett-Packard Company 1996; pp. 1-20.
- Digital HiNote VP 500 Series User's Guide; Digital Equipment Corporation; Dated Jul. 1996; © Copyright Digital Equipment Corporation 1996; pp. 1-123.
- Hard Drive: Seagate: ST51080N Medal 1080 1080 SCSI2 Fast; Dated Mar. 27, 2009, pp. 1-13.
- HP OmniBook 2000/5700 User's Guide (Windows 95); © Copyright Hewlett-Packard Company 1997; pp. 1-68.
- HP OmniBook 5000 User's Guide; Edition 1; Dated Oct. 1995; pp. 1-101.
- HP OmniBook 800 with MMX Technology; *PC Magazine*, Jan. 7, 1997; © Copyright Hewlett-Packard Company 1997.
- HP OmniBook Accessories User's Guide; © Copyright Hewlett-Packard Company 1995-1996; pp. 1-39.
- Quick Installation Guide; PCMCIA ATA Hard Drive; Simple Technology; Dated Dec. 1996. © Copyright 1996 Simple Technology Inc.; pp. 1-4.
- Proprietary Notice and Liability Disclaimer; © Copyright 1995 NEC Technologies, Inc., pp. 1-280.
- SyQuest ezziyer™ 230MB; 230 MB Portable SCSI Removable Cartridge Hard Drive; Installation Guide for PC Compatible Systems © Copyright 1997 by SyQuest Technology; Index and pp. 1-35.
- US Robotics the Intelligent Choice in Information Access User's Guide; Sportster Voice 33.600 and 28.800 Faxmodem; © Copyright 1996 by U. S. Robotics; Index and pp. 1-55.
- Zip® 100™ Parallel Port Drive User's Manual; © Copyright © 2000; Iomega Corporation; Version 2.01—Dated Jun. 6, 2000; pp. 1-42.
- Load-Date, May 25, 1997; © Copyright 1996—M2 Communications Ltd., 1 of 213 Documents; Oct. 1996.
- R. A. Berkoff; IBM® Technical Disclosure Bulletin; vol. 37; No. 08; Aug. 1994; Entitled: Direct Access Storage Device/Small Computer Systems Interface Device Support for OS/2.
- Gale Cengage Learning—PCNFS on Windows 95. (Net Worth) (Technology Information). Steven Baker. *UNIX Review* 15.n2 (Feb. 1997); pp. 13(5). (2109 words) pp. 1-6.
- "14-Bit, 2 MHz A-to-D SCSI Substation," Analoo'c ®, 1992.
- "Casio's QV-10: Portable Presentations," (2005), Retrieved from the Internet on Jun. 7, 2007: URL:<http://www.byte.com/art/9510/sec10/art10.htm>.
- "Inside Macintosh by Apple Computer, Inc.—Files" Apple Technology Library.
- Chan, "Kodak Will Market Sandisk's CompactFlash Storage Cards Under Kodak Label as Storage Media for Kodak's New DC25 Camera," SanDisk Corporation, Retrieved from the Internet on Jul. 10, 2008: URL:<http://web.archive.org/web/19961114111959/www.sandisk.com/sd/pr/kodak-ct/htm>.
- Chan, "Matsushita Introduces New Digital Camera That Uses SanDisk's CompactFlash Cards as the Digital Film." SanDisk Corporation, Public Relations (1997).
- Chan, "SanDisk to Supply Polaroid with Flash Film for New PDC-2000 Digital Camera," SanDisk Corporation. Retrieved from the Internet on Jul. 10, 2008: URL:<http://web.archive.org/web/19961114112006/www.sandisk.com/sd/pr/polaroid.htm>.
- McClelland, Deke, Color Quick Cam, Low-Cost Camera for Passable Digital Video; *Macworld*; Sep. 1996; 13, 9; ABI/Inform Global p. 79 <http://www.adobe.com>.

Explore Litigation Insights

Docket Alarm provides insights to develop a more informed litigation strategy and the peace of mind of knowing you're on top of things.

Real-Time Litigation Alerts



Keep your litigation team up-to-date with **real-time alerts** and advanced team management tools built for the enterprise, all while greatly reducing PACER spend.

Our comprehensive service means we can handle Federal, State, and Administrative courts across the country.

Advanced Docket Research



With over 230 million records, Docket Alarm's cloud-native docket research platform finds what other services can't. Coverage includes Federal, State, plus PTAB, TTAB, ITC and NLRB decisions, all in one place.

Identify arguments that have been successful in the past with full text, pinpoint searching. Link to case law cited within any court document via Fastcase.

Analytics At Your Fingertips



Learn what happened the last time a particular judge, opposing counsel or company faced cases similar to yours.

Advanced out-of-the-box PTAB and TTAB analytics are always at your fingertips.

API

Docket Alarm offers a powerful API (application programming interface) to developers that want to integrate case filings into their apps.

LAW FIRMS

Build custom dashboards for your attorneys and clients with live data direct from the court.

Automate many repetitive legal tasks like conflict checks, document management, and marketing.

FINANCIAL INSTITUTIONS

Litigation and bankruptcy checks for companies and debtors.

E-DISCOVERY AND LEGAL VENDORS

Sync your system to PACER to automate legal marketing.