

UNITED STATES PATENT AND TRADEMARK OFFICE

---

BEFORE THE PATENT TRIAL AND APPEAL BOARD

---

APPLE INC.,  
Petitioner,

v.

VOIP-PAL.COM INC.,  
Patent Owner.

---

Case IPR2016-01201  
Patent 8,542,815 B2

---

Before BARBARA A. BENOIT, LYNNE E. PETTIGREW, and  
STACY B. MARGOLIES, *Administrative Patent Judges*.

MARGOLIES, *Administrative Patent Judge*.

DECISION  
Institution of *Inter Partes* Review  
*37 C.F.R. § 42.108*

I. INTRODUCTION

Apple Inc. (“Petitioner”) filed a Petition for *inter partes* review of claims 1, 7, 27, 28, 34, 54, 72–74, 92, 93, and 111 of U.S. Patent No. 8,542,815 B2 (Ex. 1001, “the ’815 patent”). Paper 1 (“Pet.”). Voip-Pal.com, Inc. (“Patent Owner”) filed a Preliminary Response. Paper 5

(“Prelim. Resp.”). Institution of an *inter partes* review is authorized by statute when “the information presented in the petition . . . and any response . . . shows that there is a reasonable likelihood that the petitioner would prevail with respect to at least 1 of the claims challenged in the petition.” 35 U.S.C. § 314(a); *see* 37 C.F.R. § 42.108. Upon consideration of the Petition and the Preliminary Response, we conclude that the information presented shows that there is a reasonable likelihood that Petitioner would prevail in establishing the unpatentability of claims 1, 7, 27, 28, 34, 54, 72–74, 92, 93, and 111 of the ’815 patent.

#### A. *Related Matters*

The parties identify the following district court proceedings in which the ’815 patent has been asserted: *Voip-Pal.com, Inc. v. Apple, Inc.*, Case No. 2-16-cv-00260 (D. Nev.); and *Voip-Pal.com, Inc. v. Verizon Wireless Services, LLC*, Case No. 2-16-cv-00271 (D. Nev.). *See* Pet. 58; Paper 4, 1.

Petitioner also has filed a petition for *inter partes* review of claims of U.S. Patent No. 9,179,005—a continuation of the ’815 patent—in IPR2016-001198. Another petitioner—Unified Patents Inc.—filed a petition for *inter partes* review of claims of the ’815 patent in IPR2016-01082. We did not institute a trial in that case.

#### B. *The ’815 Patent*

The ’815 patent is directed to classifying a call as a public network call or a private network call and producing a routing message based on that classification. Ex. 1001, Abstract. Figure 7 of the ’815 patent, shown below, illustrates a routing controller that facilitates communication between callers and callees:

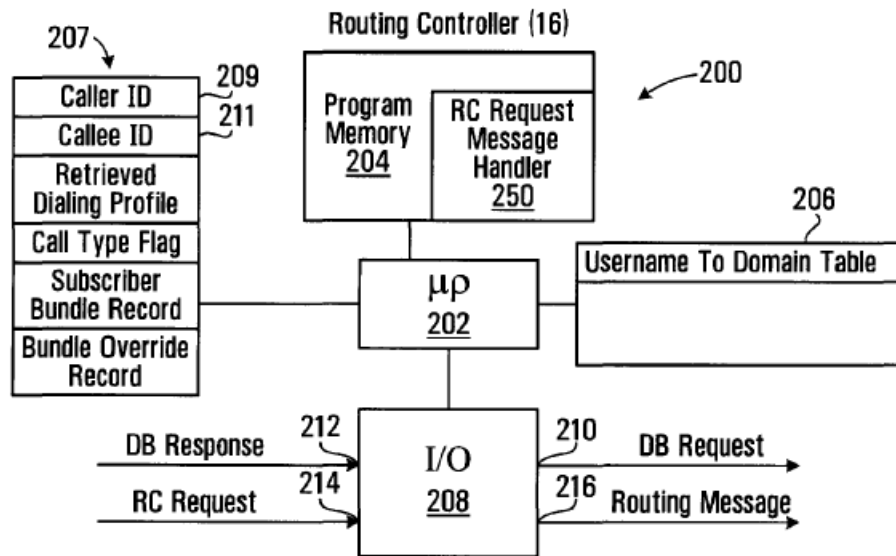

**FIG. 7**

*Id.* at Fig. 7, 14:24–25, 17:16–17. As shown in Figure 7, above, routing controller (RC) 16 includes RC processor circuit 200, which in turn includes processor 202, program memory 204, table memory 206, buffer memory 207, and I/O port 208. *Id.* at 17:17–22. Routing controller 16 queries database 18 (shown in Figure 1) to produce a routing message to connect caller and callee. *Id.* at 14:10–17, 14:24–34. Program memory 204 includes blocks of code for directing processor 202 to carry out various functions of the routing controller. *Id.* at 17:38–40. Those blocks of code include RC request message handler 250, which directs the routing controller to produce the routing message. *Id.* at 17:40–44.

According to the '815 patent, in response to a calling subscriber initiating a call, the routing controller:

receiv[es] a callee identifier from the calling subscriber, us[es] call classification criteria associated with the calling subscriber to classify the call as a public network call or a private network call[,] and produc[es] a routing message identifying an address

on the private network, associated with the callee[,] when the call is classified as a private network call and produc[es] a routing message identifying a gateway to the public network when the call is classified as a public network call.

*Id.* at 14:24–34.

Figures 8A through 8D of the '815 patent illustrate a flowchart of an RC request message handler executed by the RC processor circuit. *Id.* at 10:62–63. Figure 8B, shown below, illustrates steps for performing checks on the callee identifier:

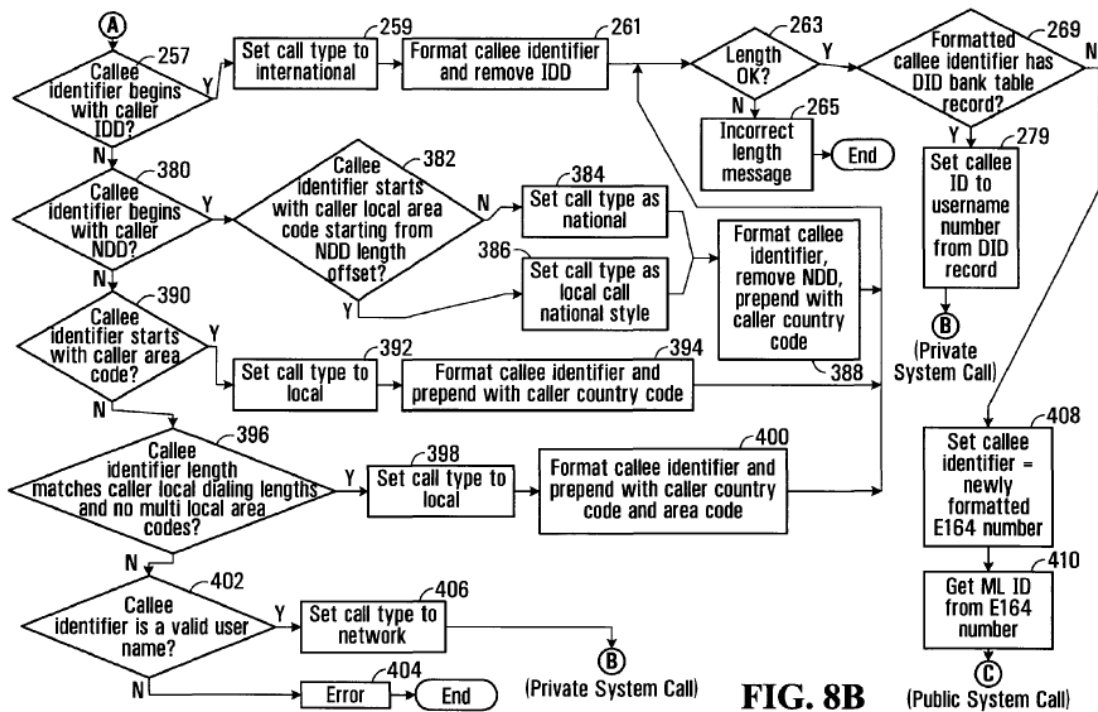

**FIG. 8B** (Private System Call) (Public System Call)

*Id.* at Fig. 8B, 19:45–49. Blocks 257, 380, 390, 396, 402 in Figure 8B above effectively “establish call classification criteria for classifying the call as a public network call or a private network call.” *Id.* at 22:48–51. For example, block 402 “directs the processor 202 of FIG. 7 to classify the call as a private network call when the callee identifier complies with a

predefined format, i.e. is a valid user name and identifies a subscriber to the private network . . . .” *Id.* at 22:51–60. Block 269 also classifies the call as public or private, depending on whether the callee is a subscriber to the system. *Id.* at 22:51–23:8, 20:14–24; *see also id.* at 18:55–19:22.

### *C. Illustrative Claim*

Among the challenged claims, claims 1, 27, 28, 54, 74, and 93 are independent. Claim 1 is illustrative and reads:

1. A process for operating a call routing controller to facilitate communication between callers and callees in a system comprising a plurality of nodes with which callers and callees are associated, the process comprising:

in response to initiation of a call by a calling subscriber, receiving a caller identifier and a callee identifier;

locating a caller dialing profile comprising a username associated with the caller and a plurality of calling attributes associated with the caller;

determining a match when at least one of said calling attributes matches at least a portion of said callee identifier;

classifying the call as a public network call when said match meets public network classification criteria and classifying the call as a private network call when said match meets private network classification criteria;

when the call is classified as a private network call, producing a private network routing message for receipt by a call controller, said private network routing message identifying an address, on the private network, associated with the callee;

when the call is classified as a public network call, producing a public network routing message for receipt by the call controller, said public network routing message identifying a gateway to the public network.

*Id.* at 36:14–38.

# Explore Litigation Insights

Docket Alarm provides insights to develop a more informed litigation strategy and the peace of mind of knowing you're on top of things.

## Real-Time Litigation Alerts



Keep your litigation team up-to-date with **real-time alerts** and advanced team management tools built for the enterprise, all while greatly reducing PACER spend.

Our comprehensive service means we can handle Federal, State, and Administrative courts across the country.

## Advanced Docket Research



With over 230 million records, Docket Alarm's cloud-native docket research platform finds what other services can't. Coverage includes Federal, State, plus PTAB, TTAB, ITC and NLRB decisions, all in one place.

Identify arguments that have been successful in the past with full text, pinpoint searching. Link to case law cited within any court document via Fastcase.

## Analytics At Your Fingertips



Learn what happened the last time a particular judge, opposing counsel or company faced cases similar to yours.

Advanced out-of-the-box PTAB and TTAB analytics are always at your fingertips.

## API

Docket Alarm offers a powerful API (application programming interface) to developers that want to integrate case filings into their apps.

## LAW FIRMS

Build custom dashboards for your attorneys and clients with live data direct from the court.

Automate many repetitive legal tasks like conflict checks, document management, and marketing.

## FINANCIAL INSTITUTIONS

Litigation and bankruptcy checks for companies and debtors.

## E-DISCOVERY AND LEGAL VENDORS

Sync your system to PACER to automate legal marketing.