

20427 U.S. PTO
030706

IN THE UNITED STATES PATENT AND TRADEMARK OFFICE

112959 U.S. PTO
11/370114

030706

Applicants : Yigal Mordechai Edery et al.

U.S. Serial No. : unknown

Filed : herewith

Title : MALICIOUS MOBILE CODE RUNTIME MONITORING SYSTEM AND METHODS

Group Art Unit : unknown

Examiner : unknown

EXPRESS MAIL MAILING LABEL NUMBER EQ 399946563 US, Date of Deposit: March 7, 2006

I hereby certify that this paper or fee is being deposited with the United States Postal Service "Express Mail Post Office to Addressee" Service under 37 CFR 1.10 on the date indicated above and is addressed to the Commissioner for Patents, P.O. Box 1450, Alexandria, VA 22313-1450.

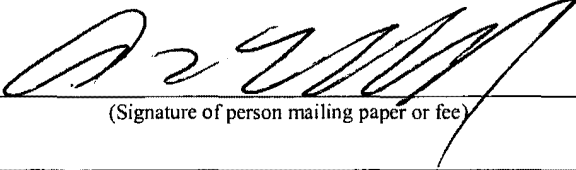
Andrew L. Tiajloff  March 7, 2006

(Name of person mailing paper or fee) (Signature of person mailing paper or fee) Date

Commissioner for Patents
P.O. Box 1450
Alexandria, VA 22313-1450

PATENT APPLICATION TRANSMITTAL LETTER

Sir:

Attorney for the above-captioned applicants transmits herewith the following:

1. a fee transmittal sheet (1 page);
2. an application data sheet (3 pages);
3. the application, which is a copy of the parent application as filed, comprising a cover sheet (1 page), specification (42 pages), claims (15 pages), drawings (10 pages), and abstract (1 page);

3E959466E03

4. a copy of an executed declaration of the inventors from the parent application;
- and
5. a Preliminary Amendment and Information Disclosure Statement.

PLEASE ASSOCIATE THIS APPLICATION WITH CUSTOMER NUMBER

43214.

Should any questions arise, the Patent Office is invited to telephone attorney for applicants at 212-490-3285.

Respectfully submitted,

CUSTOMER NUMBER
43214
U.S. PATENT TRADEMARK OFFICE

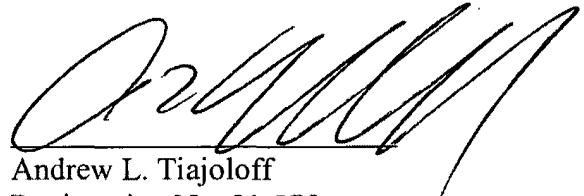

Andrew L. Tiajolloff
Registration No. 31,575

Tiajolloff & Kelly
Chrysler Building, 37th floor
405 Lexington Avenue
New York, NY 10174

tel. 212-490-3285
fax 212-490-3295

Under the Paperwork Reduction Act of 1995, no persons are required to respond to a collection of information unless it displays a valid OMB control number.

030706

20447 U.S. PTO

FEE TRANSMITTAL for FY 2005

Effective 12/08/2004

Complete if Known

Application Number	
Filing Date	
First Named Inventor	EDERY, Yigal Mordechai
Examiner Name	
Group / Art Unit	
Attorney Docket No.	P-9139-US2

Applicant claims small entity status. See 37 CFR 1.27

TOTAL AMOUNT OF PAYMENT (\$)**7350**

METHOD OF PAYMENT (check all that apply)

Check Credit Card Money Order None Other (please specify): _____

Deposit Account Number **50-3400** Deposit Account Name: **Eitan Law Group**

For the above-identified deposit account, the Director is hereby authorized to: (check all that apply)

Charge fee(s) indicated below Charge fee(s) indicated below, except for the filing fee
 Charge any additional fee(s) or underpayments of fee(s) under 37 CFE 1.16 and 1.17 Credit any overpayments

WARNING: Information on this form may become public. Credit card information should not be included on this form. Provide credit card information and authorization on PTO-2038.

FEE CALCULATION

1. BASIC FILING, SEARCH, AND EXAMINATION FEES

Application Type	FILING FEES		SEARCH FEES		EXAMINATION FEES		Fees Paid (\$)
	Fee (\$)	Small Entity Fee (\$)	Fee (\$)	Small Entity Fee (\$)	Fee (\$)	Small Entity Fee (\$)	
Utility	300	150	500	250	200	100	1000
Design	200	100	100	50	130	65	
Plant	200	100	300	150	160	80	
Reissue	300	150	500	250	600	300	
Provisional	200	100	0	0	0	0	

2. EXCESS CLAIM FEES

Fee Description	Small Entity Fee (\$)	Fee (\$)	Fee Paid (\$)
Each claim over 20 or, for Reissues, each claim over 20 and more than in the original patent	50	25	
Each independent claim over 3 or, for Reissues, each independent claim more than in the original patent	200	100	
Multiple dependent claims	360	180	
Total Claims	75	55	2750
HP = highest number of total claims paid for, if greater than 20.	-20 or HP =	x	
Indep. Claims	21	18	3600
HP = highest number of independent claims paid for, if greater than 3.	-3 or HP =	x	

3. APPLICATION SIZE FEE

If the specification and drawings exceed 100 sheets of paper, the application size fee due is \$250 (\$125 for small entity) for each additional 50 sheets or fraction thereof. See 35 U.S.C. 41(a)(1)(G) and 37 CFR 1.16(s).

Total Sheets	Extra Sheets	Number of each additional 50 or fraction thereof	Fee (\$)	Fee Paid (\$)
-100	/ 50 =	(round up to a whole number)	x	=

4. OTHER FEE(S)

Non-English Specification, \$130 fee (no small entity discount)
 Other fee(s):

SUBMITTED BY

Name (Print /Type)	Registration No. (Attorney/Agent)	Telephone	Complete (if applicable)	
Tally Eitan			(212) 490-3285	
Signature		Date	March 7, 2006	

This collection of information is required by 37 CFR 1.136. The information is required to obtain or retain a benefit by the public which is to file (and by the USPTO to process) an application. Confidentiality is governed by 35 U.S.C. 122 and 37 CFR 1.14. This collection is estimated to take 30 minutes to complete, including gathering, preparing, and submitting the completed application form to the USPTO. Time will vary depending upon the individual case. Any comments on the amount of time you require to complete this form and/or suggestions for reducing this burden, should be sent to the Chief Information Officer, U.S. Patent and Trademark Office, U.S. Department of Commerce, P.O. Box 1450, Alexandria, VA 22313-1450. DO NOT SEND FEES OR COMPLETED FORMS TO THIS ADDRESS. SEND TO: Commissioner for Patents, P.O. Box 1450, Alexandria, VA 22313-1450.

If you need assistance in completing the form, call 1-800-PTO-9199 and select option 2.

20427 U.S. PTO
030706

IN THE UNITED STATES PATENT AND TRADEMARK OFFICE

112959 U.S. PTO
11/370114
030706

Applicants : Yigal Mordechai Edery et al.
U.S. Serial No. : unknown
Filed : herewith
Title : MALICIOUS MOBILE CODE RUNTIME MONITORING SYSTEM AND METHODS
Group Art Unit : unknown
Examiner : unknown

EXPRESS MAIL MAILING LABEL NUMBER EQ 399946563 US, Date of Deposit: March 7, 2006

I hereby certify that this paper or fee is being deposited with the United States Postal Service "Express Mail Post Office to Addressee" Service under 37 CFR 1.10 on the date indicated above and is addressed to the Commissioner for Patents, P.O. Box 1450, Alexandria, VA 22313-1450.

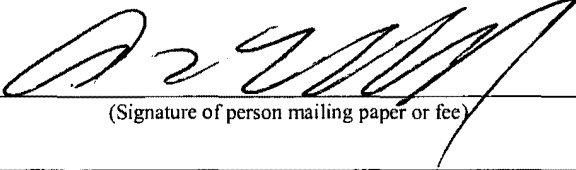
Andrew L. Tjajoloff  March 7, 2006
(Name of person mailing paper or fee) (Signature of person mailing paper or fee) Date

Commissioner for Patents
P.O. Box 1450
Alexandria, VA 22313-1450

PATENT APPLICATION TRANSMITTAL LETTER

Sir:

Attorney for the above-captioned applicants transmits herewith the following:

1. a fee transmittal sheet (1 page);
2. an application data sheet (3 pages);
3. the application, which is a copy of the parent application as filed, comprising a cover sheet (1 page), specification (42 pages), claims (15 pages), drawings (10 pages), and abstract (1 page);

SNE9594666E03

4. a copy of an executed declaration of the inventors from the parent application;
- and
5. a Preliminary Amendment and Information Disclosure Statement.

PLEASE ASSOCIATE THIS APPLICATION WITH CUSTOMER NUMBER

43214.

Should any questions arise, the Patent Office is invited to telephone attorney for applicants at 212-490-3285.

Respectfully submitted,

CUSTOMER NUMBER
43214
U.S. PATENT TRADEMARK OFFICE

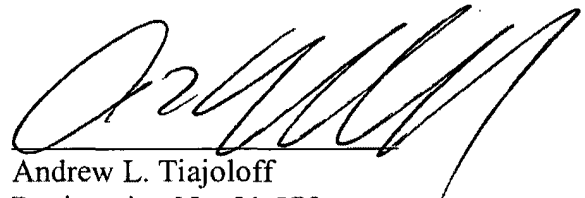

Andrew L. Tiajolloff
Registration No. 31,575

Tiajolloff & Kelly
Chrysler Building, 37th floor
405 Lexington Avenue
New York, NY 10174

tel. 212-490-3285
fax 212-490-3295

Under the Paperwork Reduction Act of 1995, no persons are required to respond to a collection of information unless it displays a valid OMB control number.

030706

20447 U.S. PTO

FEE TRANSMITTAL for FY 2005

Effective 12/08/2004

Complete if Known

Application Number	
Filing Date	
First Named Inventor	EDERY, Yigal Mordechai
Examiner Name	
Group / Art Unit	
Attorney Docket No.	P-9139-US2

Applicant claims small entity status. See 37 CFR 1.27

TOTAL AMOUNT OF PAYMENT (\$)**7350**

METHOD OF PAYMENT (check all that apply)

Check
 Credit Card
 Money Order
 None
 Other (please specify): _____
 Deposit Account Number **50-3400** Deposit Account Name: **Eitan Law Group**
 For the above-identified deposit account, the Director is hereby authorized to: (check all that apply)
 Charge fee(s) indicated below Charge fee(s) indicated below, except for the filing fee
 Charge any additional fee(s) or underpayments of fee(s) under 37 CFE 1.16 and 1.17 Credit any overpayments

WARNING: Information on this form may become public. Credit card information should not be included on this form. Provide credit card information and authorization on PTO-2038.

FEE CALCULATION

1. BASIC FILING, SEARCH, AND EXAMINATION FEES

Application Type	FILING FEES		SEARCH FEES		EXAMINATION FEES		Fees Paid (\$)
	Fee (\$)	Small Entity Fee (\$)	Fee (\$)	Small Entity Fee (\$)	Fee (\$)	Small Entity Fee (\$)	
Utility	300	150	500	250	200	100	1000
Design	200	100	100	50	130	65	
Plant	200	100	300	150	160	80	
Reissue	300	150	500	250	600	300	
Provisional	200	100	0	0	0	0	

2. EXCESS CLAIM FEES

Fee Description	Small Entity Fee (\$)	Fee (\$)	Fee Paid (\$)
Each claim over 20 or, for Reissues, each claim over 20 and more than in the original patent	50		25
Each independent claim over 3 or, for Reissues, each independent claim more than in the original patent	200		100
Multiple dependent claims	360		180
Total Claims		Extra Claims	Fee Paid (\$)
<u>75</u> -20 or HP =	<u>55</u> x	<u>50</u>	<u>2750</u>
HP = highest number of total claims paid for, if greater than 20.			
Indep. Claims		Extra Claims	Fee Paid (\$)
<u>21</u> -3 or HP =	<u>18</u> x	<u>200</u>	<u>3600</u>
HP = highest number of independent claims paid for, if greater than 3.			

3. APPLICATION SIZE FEE

If the specification and drawings exceed 100 sheets of paper, the application size fee due is \$250 (\$125 for small entity) for each additional 50 sheets or fraction thereof. See 35 U.S.C. 41(a)(1)(G) and 37 CFR 1.16(s).

Total Sheets	Extra Sheets	Number of each additional 50 or fraction thereof	Fee (\$)	Fee Paid (\$)
<u> </u> -100	<u> </u> / 50 =	<u> </u> (round up to a whole number) x	<u> </u> =	<u> </u>

4. OTHER FEE(S)

Non-English Specification, \$130 fee (no small entity discount)
 Other fee(s): _____

SUBMITTED BY

Name (Print /Type)	Registration No. (Attorney/Agent)	Telephone	Complete (if applicable)	
Tally Eitan			(212) 490-3285	
Signature		Date	March 7, 2006	

This collection of information is required by 37 CFR 1.136. The information is required to obtain or retain a benefit by the public which is to file (and by the USPTO to process) an application. Confidentiality is governed by 35 U.S.C. 122 and 37 CFR 1.14. This collection is estimated to take 30 minutes to complete, including gathering, preparing, and submitting the completed application form to the USPTO. Time will vary depending upon the individual case. Any comments on the amount of time you require to complete this form and/or suggestions for reducing this burden, should be sent to the Chief Information Officer, U.S. Patent and Trademark Office, U.S. Department of Commerce, P.O. Box 1450, Alexandria, VA 22313-1450. DO NOT SEND FEES OR COMPLETED FORMS TO THIS ADDRESS. SEND TO: Commissioner for Patents, P.O. Box 1450, Alexandria, VA 22313-1450.

If you need assistance in completing the form, call 1-800-PTO-9199 and select option 2.

**APPLICATION FOR
UNITED STATES PATENT
IN THE NAME OF**

Yigal Edery, Nimrod Vered and David Kroll

OF

FINJAN SOFTWARE, LTD.

**MALICIOUS MOBILE CODE RUNTIME MONITORING
SYSTEM AND METHODS**

DOCKET NO. 43426.00014

Please direct communications to:

**Intellectual Property Department
Squire, Sanders & Dempsey L.L.P.
600 Hansen Way
Palo Alto, CA 94304-1043
(650) 856-6500**

Express Mail Number EL 701 364 624

FOR "6279860"

MALICIOUS MOBILE CODE RUNTIME MONITORINGSYSTEM AND METHODSPRIORITY REFERENCE TO RELATED APPLICATIONS

5 This application claims benefit of and hereby incorporates by reference
provisional application serial number 60/205,591, entitled "Computer Network Malicious
Code Run-time Monitoring," filed on May 17, 2000 by inventors Nimrod Itzhak Vered, et
al. This application is also a Continuation-In-Part of and hereby incorporates by
reference patent application serial number 09/539,667, entitled "System and Method for
10 Protecting a Computer and a Network From Hostile Downloadables" filed on March 30,
2000 by inventor Shlomo Touboul. This application is also a Continuation-In-Part of and
hereby incorporates by reference patent application serial number 09/551,302, entitled
"System and Method for Protecting a Client During Runtime From Hostile
Downloadables", filed on April 18, 2000 by inventor Shlomo Touboul.

BACKGROUND OF THE INVENTIONField of the Invention

 This invention relates generally to computer networks, and more particularly
20 provides a system and methods for protecting network-connectable devices from
undesirable downloadable operation.

Description of the Background Art

Advances in networking technology continue to impact an increasing number and diversity of users. The Internet, for example, already provides to expert, intermediate and even novice users the informational, product and service resources of over 100,000 interconnected networks owned by governments, universities, nonprofit groups, companies, etc. Unfortunately, particularly the Internet and other public networks have also become a major source of potentially system-fatal or otherwise damaging computer code commonly referred to as "viruses."

Efforts to forestall viruses from attacking networked computers have thus far met with only limited success at best. Typically, a virus protection program designed to identify and remove or protect against the initiating of known viruses is installed on a network firewall or individually networked computer. The program is then inevitably surmounted by some new virus that often causes damage to one or more computers. The damage is then assessed and, if isolated, the new virus is analyzed. A corresponding new virus protection program (or update thereof) is then developed and installed to combat the new virus, and the new program operates successfully until yet another new virus appears - and so on. Of course, damage has already typically been incurred.

To make matters worse, certain classes of viruses are not well recognized or understood, let alone protected against. It is observed by this inventor, for example, that Downloadable information comprising program code can include distributable components (e.g. Java™ applets and JavaScript scripts, ActiveX™ controls, Visual Basic, add-ins and/or others). It can also include, for example, application programs, Trojan horses, multiple compressed programs such as zip or meta files, among others. U.S. Patent 5,983,348 to Shuang, however, teaches a protection system for protecting

against only distributable components including “Java applets or ActiveX controls”, and further does so using resource intensive and high bandwidth static Downloadable content and operational analysis, and modification of the Downloadable component; Shuang further fails to detect or protect against additional program code included within a tested
 5 Downloadable. U.S. Patent 5,974,549 to Golan teaches a protection system that further focuses only on protecting against ActiveX controls and not other distributable components, let alone other Downloadable types. U.S. patent 6,167,520 to Touboul enables more accurate protection than Shuang or Golan, but lacks the greater flexibility and efficiency taught herein, as do Shuang and Golan.

10 Accordingly, there remains a need for efficient, accurate and flexible protection of computers and other network connectable devices from malicious Downloadables.

SUMMARY OF THE INVENTION

15 The present invention provides protection systems and methods capable of protecting a personal computer (“PC”) or other persistently or even intermittently network accessible devices or processes from harmful, undesirable, suspicious or other “malicious” operations that might otherwise be effectuated by remotely operable code. While enabling the capabilities of prior systems, the present invention is not nearly so limited, resource intensive or inflexible, and yet enables more reliable protection. For
 20 example, remotely operable code that is protectable against can include downloadable application programs, Trojan horses and program code groupings, as well as software “components”, such as Java™ applets, ActiveX™ controls, JavaScript™/Visual Basic scripts, add-ins, etc., among others. Protection can also be provided in a distributed

interactively, automatically or mixed configurable manner using protected client, server or other parameters, redirection, local/remote logging, etc., and other server/client based protection measures can also be separately and/or interoperably utilized, among other examples.

5 In one aspect, embodiments of the invention provide for determining, within one or more network “servers” (e.g. firewalls, resources, gateways, email relays or other devices/processes that are capable of receiving-and-transferring a Downloadable) whether received information includes executable code (and is a “Downloadable”). Embodiments also provide for delivering static, configurable and/or extensible remotely operable
10 protection policies to a Downloadable-destination, more typically as a sandboxed package including the mobile protection code, downloadable policies and one or more received Downloadables. Further client-based or remote protection code/policies can also be utilized in a distributed manner. Embodiments also provide for causing the mobile protection code to be executed within a Downloadable-destination in a manner that
15 enables various Downloadable operations to be detected, intercepted or further responded to via protection operations. Additional server/information-destination device security or other protection is also enabled, among still further aspects.

A protection engine according to an embodiment of the invention is operable within one or more network servers, firewalls or other network connectable information
20 re-communicating devices (as are referred to herein summarily one or more “servers” or “re-communicators”). The protection engine includes an information monitor for monitoring information received by the server, and a code detection engine for determining whether the received information includes executable code. The protection

engine also includes a packaging engine for causing a sandboxed package, typically including mobile protection code and downloadable protection policies to be sent to a Downloadable-destination in conjunction with the received information, if the received information is determined to be a Downloadable.

5 A sandboxed package according to an embodiment of the invention is receivable by and operable with a remote Downloadable-destination. The sandboxed package includes mobile protection code (“MPC”) for causing one or more predetermined malicious operations or operation combinations of a Downloadable to be monitored or otherwise intercepted. The sandboxed package also includes protection policies (operable
10 alone or in conjunction with further Downloadable-destination stored or received policies/MPCs) for causing one or more predetermined operations to be performed if one or more undesirable operations of the Downloadable is/are intercepted. The sandboxed package can also include a corresponding Downloadable and can provide for initiating the Downloadable in a protective “sandbox”. The MPC/policies can further include a
15 communicator for enabling further MPC/policy information or “modules” to be utilized and/or for event logging or other purposes.

A sandbox protection system according to an embodiment of the invention comprises an installer for enabling a received MPC to be executed within a Downloadable-destination (device/process) and further causing a Downloadable
20 application program, distributable component or other received downloadable code to be received and installed within the Downloadable-destination. The protection system also includes a diverter for monitoring one or more operation attempts of the Downloadable, an operation analyzer for determining one or more responses to the attempts, and a

security enforcer for effectuating responses to the monitored operations. The protection system can further include one or more security policies according to which one or more protection system elements are operable automatically (e.g. programmatically) or in conjunction with user intervention (e.g. as enabled by the security enforcer). The security policies can also be configurable/extensible in accordance with further downloadable and/or Downloadable-destination information.

A method according to an embodiment of the invention includes receiving downloadable information, determining whether the downloadable information includes executable code, and causing a mobile protection code and security policies to be communicated to a network client in conjunction with security policies and the downloadable information if the downloadable information is determined to include executable code. The determining can further provide multiple tests for detecting, alone or together, whether the downloadable information includes executable code.

A further method according to an embodiment of the invention includes forming a sandboxed package that includes mobile protection code ("MPC"), protection policies, and a received, detected-Downloadable, and causing the sandboxed package to be communicated to and installed by a receiving device or process ("user device") for responding to one or more malicious operation attempts by the detected-Downloadable from within the user device. The MPC/policies can further include a base "module" and a "communicator" for enabling further up/downloading of one or more further "modules" or other information (e.g. events, user/user device information, etc.).

Another method according to an embodiment of the invention includes installing, within a user device, received mobile protection code ("MPC") and protection policies in

conjunction with the user device receiving a downloadable application program,
component or other Downloadable(s). The method also includes determining, by the
MPC, a resource access attempt by the Downloadable, and initiating, by the MPC, one or
more predetermined operations corresponding to the attempt. (Predetermined operations
5 can, for example, comprise initiating user, administrator, client, network or protection
system determinable operations, including but not limited to modifying the Downloadable
operation, extricating the Downloadable, notifying a user/another, maintaining a
local/remote log, causing one or more MPCs/policies to be downloaded, etc.)

Advantageously, systems and methods according to embodiments of the invention
10 enable potentially damaging, undesirable or otherwise malicious operations by even
unknown mobile code to be detected, prevented, modified and/or otherwise protected
against without modifying the mobile code. Such protection is further enabled in a
manner that is capable of minimizing server and client resource requirements, does not
require pre-installation of security code within a Downloadable-destination, and provides
15 for client specific or generic and readily updateable security measures to be flexibly and
efficiently implemented. Embodiments further provide for thwarting efforts to bypass
security measures (e.g. by "hiding" undesirable operation causing information within
apparently inert or otherwise "friendly" downloadable information) and/or dividing or
combining security measures for even greater flexibility and/or efficiency.

20 Embodiments also provide for determining protection policies that can be
downloaded and/or ascertained from other security information (e.g. browser settings,
administrative policies, user input, uploaded information, etc.). Different actions in
response to different Downloadable operations, clients, users and/or other criteria are also

BRIEF DESCRIPTION OF THE DRAWINGS

FIG. 1a is a block diagram illustrating a network system in accordance with an embodiment of the present invention;

FIG. 1b is a block diagram illustrating a network subsystem example in accordance with an embodiment of the invention;

FIG. 1c is a block diagram illustrating a further network subsystem example in accordance with an embodiment of the invention;

FIG. 2 is a block diagram illustrating a computer system in accordance with an embodiment of the invention;

FIG. 3 is a flow diagram broadly illustrating a protection system host according to an embodiment of the invention;

FIG. 4 is a block diagram illustrating a protection engine according to an embodiment of the invention;

FIG. 5 is a block diagram illustrating a content inspection engine according to an embodiment of the invention;

FIG. 6a is a block diagram illustrating protection engine parameters according to an embodiment of the invention;

FIG. 6b is a flow diagram illustrating a linking engine use in conjunction with ordinary, compressed and distributable sandbox package utilization, according to an embodiment of the invention;

FIG. 7a is a flow diagram illustrating a sandbox protection system operating within a destination system, according to an embodiment of the invention;

10
15
20

FIG. 7b is a block diagram illustrating memory allocation usable in conjunction with the protection system of FIG. 7a, according to an embodiment of the invention;

FIG. 7c is a block diagram illustrating a mobile protection code according to an embodiment of the invention;

5 FIG. 8 is a flowchart illustrating a method for examining a Downloadable in accordance with the present invention;

FIG. 9 is a flowchart illustrating a server based protection method according to an embodiment of the invention;

10 FIG. 10a is a flowchart illustrating method for determining if a potential- Downloadable includes or is likely to include executable code, according to an embodiment of the invention;

FIG. 10b is a flowchart illustrating a method for forming a protection agent, according to an embodiment of the invention;

15 FIG. 11 is a flowchart illustrating a method for protecting a Downloadable destination according to an embodiment of the invention;

FIG. 12a is a flowchart illustrating a method for forming a Downloadable access interceptor according to an embodiment of the invention; and

FIG. 12b is a flowchart illustrating a method for implementing mobile protection policies according to an embodiment of the invention.

20

DETAILED DESCRIPTION

In providing malicious mobile code runtime monitoring systems and methods, embodiments of the invention enable actually or potentially undesirable operations of even unknown malicious code to be efficiently and flexibly avoided. Embodiments provide, within one or more “servers” (e.g. firewalls, resources, gateways, email relays or other information re-communicating devices), for receiving downloadable-information and detecting whether the downloadable-information includes one or more instances of executable code (e.g. as with a Trojan horse, zip/meta file etc.). Embodiments also provide for separately or interoperably conducting additional security measures within the server, within a Downloadable-destination of a detected-Downloadable, or both.

Embodiments further provide for causing mobile protection code (“MPC”) and downloadable protection policies to be communicated to, installed and executed within one or more received information destinations in conjunction with a detected-Downloadable. Embodiments also provide, within an information-destination, for detecting malicious operations of the detected-Downloadable and causing responses thereto in accordance with the protection policies (which can correspond to one or more user, Downloadable, source, destination, or other parameters), or further downloaded or downloadable-destination based policies (which can also be configurable or extensible). (Note that the term “or”, as used herein, is generally intended to mean “and/or” unless otherwise indicated.)

FIGS. 1a through 1c illustrate a computer network system 100 according to an embodiment of the invention. FIG. 1a broadly illustrates system 100, while FIGS. 1b and

1c illustrate exemplary protectable subsystem implementations corresponding with system 104 or 106 of FIG. 1a.

Beginning with FIG. 1a, computer network system 100 includes an external computer network 101, such as a Wide Area Network or “WAN” (e.g. the Internet), which is coupled to one or more network resource servers (summarily depicted as resource server-1 102 and resource server-N 103). Where external network 101 includes the Internet, resource servers 1-N (102, 103) might provide one or more resources including web pages, streaming media, transaction-facilitating information, program updates or other downloadable information, summarily depicted as resources 121, 131 and 132. Such information can also include more traditionally viewed “Downloadables” or “mobile code” (i.e. distributable components), as well as downloadable application programs or other further Downloadables, such as those that are discussed herein. (It will be appreciated that interconnected networks can also provide various other resources as well.)

Also coupled via external network 101 are subsystems 104-106. Subsystems 104-106 can, for example, include one or more servers, personal computers (“PCs”), smart appliances, personal information managers or other devices/processes that are at least temporarily or otherwise intermittently directly or indirectly connectable in a wired or wireless manner to external network 101 (e.g. using a dialup, DSL, cable modem, cellular connection, IR/RF, or various other suitable current or future connection alternatives). One or more of subsystems 104-106 might further operate as user devices that are connectable to external network 101 via an internet service provider (“ISP”) or

local area network (“LAN”), such as a corporate intranet, or home, portable device or smart appliance network, among other examples.

FIG. 1a also broadly illustrates how embodiments of the invention are capable of selectively, modifiably or extensibly providing protection to one or more determinable ones of networked subsystems 104-106 or elements thereof (not shown) against potentially harmful or other undesirable (“malicious”) effects in conjunction with receiving downloadable information. “Protected” subsystem 104, for example, utilizes a protection in accordance with the teachings herein, while “unprotected” subsystem-N 105 employs no protection, and protected subsystem-M 106 might employ one or more protections including those according to the teachings herein, other protection, or some combination.

System 100 implementations are also capable of providing protection to redundant elements 107 of one or more of subsystems 104-106 that might be utilized, such as backups, failsafe elements, redundant networks, etc. Where included, such redundant elements are also similarly protectable in a separate, combined or coordinated manner using embodiments of the present invention either alone or in conjunction with other protection mechanisms. In such cases, protection can be similarly provided singly, as a composite of component operations or in a backup fashion. Care should, however, be exercised to avoid potential repeated protection engine execution corresponding to a single Downloadable; such “chaining” can cause a Downloadable to operate incorrectly or not at all, unless a subsequent detection engine is configured to recognize a prior packaging of the Downloadable..

FIGS. 1b and 1c further illustrate, by way of example, how protection systems according to embodiments of the invention can be utilized in conjunction with a wide variety of different system implementations. In the illustrated examples, system elements are generally configurable in a manner commonly referred to as a “client-server” configuration, as is typically utilized for accessing Internet and many other network resources. For clarity sake, a simple client-server configuration will be presumed unless otherwise indicated. It will be appreciated, however, that other configurations of interconnected elements might also be utilized (e.g. peer-peer, routers, proxy servers, networks, converters, gateways, services, network reconfiguring elements, etc.) in accordance with a particular application.

The FIG. 1b example shows how a suitable protected system 104a (which can correspond to subsystem-1 104 or subsystem-M 106 of FIG. 1) can include a protection-initiating host “server” or “re-communicator” (e.g. ISP server 140a), one or more user devices or “Downloadable-destinations” 145, and zero or more redundant elements (which elements are summarily depicted as redundant client device/process 145a). In this example, ISP server 140a includes one or more email, Internet or other servers 141a, or other devices or processes capable of transferring or otherwise “re-communicating” downloadable information to user devices 145. Server 141a further includes protection engine or “PE” 142a, which is capable of supplying mobile protection code (“MPC”) and protection policies for execution by client devices 145. One or more of user devices 145 can further include a respective one or more clients 146 for utilizing information received via server 140a, in accordance with which MPC and protection policies are operable to

protect user devices 145 from detrimental, undesirable or otherwise “malicious” operations of downloadable information also received by user device 145.

The FIG. 1c example shows how a further suitable protected system 104b can include, in addition to a “re-communicator”, such as server 142b, a firewall 143c (e.g. as is typically the case with a corporate intranet and many existing or proposed home/smart networks.) In such cases, a server 141b or firewall 143 can operate as a suitable protection engine host. A protection engine can also be implemented in a more distributed manner among two or more protection engine host systems or host system elements, such as both of server 141b and firewall 143, or in a more integrated manner, for example, as a standalone device. Redundant system or system protection elements can also be similarly provided in a more distributed or integrated manner (see above).

System 104b also includes internal network 144 and user devices 145. User devices 145 further include a respective one or more clients 146 for utilizing information received via server 140a, in accordance with which the MPCs or protection policies are operable. (As in the previous example, one or more of user devices 145 can also include or correspond with similarly protectable redundant system elements, which are not shown.)

It will be appreciated that the configurations of FIGS 1a-1c are merely exemplary. Alternative embodiments might, for example, utilize other suitable connections, devices or processes. One or more devices can also be configurable to operate as a network server, firewall, smart router, a resource server servicing deliverable third-party/manufacture postings, a user device operating as a firewall/server, or other information-suppliers or intermediaries (i.e. as a “re-communicator” or “server”) for

servicing one or more further interconnected devices or processes or interconnected levels of devices or processes. Thus, for example, a suitable protection engine host can include one or more devices or processes capable of providing or supporting the providing of mobile protection code or other protection consistent with the teachings herein. A
5 suitable information-destination or “user device” can further include one or more devices or processes (such as email, browser or other clients) that are capable of receiving and initiating or otherwise hosting a mobile code execution.

FIG. 2 illustrates an exemplary computing system 200, that can comprise one or more of the elements of FIGS. 1a through 1c. While other application-specific
10 alternatives might be utilized, it will be presumed for clarity sake that system 100 elements (FIGS. 1a-c) are implemented in hardware, software or some combination by one or more processing systems consistent therewith, unless otherwise indicated.

Computer system 200 comprises elements coupled via communication channels (e.g. bus 201) including one or more general or special purpose processors 202, such as a
15 Pentium® or Power PC®, digital signal processor (“DSP”), etc. System 200 elements also include one or more input devices 203 (such as a mouse, keyboard, microphone, pen, etc.), and one or more output devices 204, such as a suitable display, speakers, actuators, etc., in accordance with a particular application.

System 200 also includes a computer readable storage media reader 205 coupled
20 to a computer readable storage medium 206, such as a storage/memory device or hard or removable storage/memory media; such devices or media are further indicated separately as storage device 208 and memory 209, which can include hard disk variants, floppy/compact disk variants, digital versatile disk (“DVD”) variants, smart cards, read

only memory, random access memory, cache memory, etc., in accordance with a particular application. One or more suitable communication devices 207 can also be included, such as a modem, DSL, infrared or other suitable transceiver, etc. for providing inter-device communication directly or via one or more suitable private or public networks that can include but are not limited to those already discussed.

Working memory further includes operating system (“OS”) elements and other programs, such as application programs, mobile code, data, etc. for implementing system elements that might be stored or loaded therein during use. The particular OS can vary in accordance with a particular device, features or other aspects in accordance with a particular application (e.g. Windows, Mac, Linux, Unix or Palm OS variants, a proprietary OS, etc.). Various programming languages or other tools can also be utilized, such as C++, Java, Visual Basic, etc. As will be discussed, embodiments can also include a network client such as a browser or email client, e.g. as produced by Netscape, Microsoft or others, a mobile code executor such as an OS task manager, Java Virtual Machine (“JVM”), etc., and an application program interface (“API”), such as a Microsoft Windows or other suitable element in accordance with the teachings herein. (It will also become apparent that embodiments might also be implemented in conjunction with a resident application or combination of mobile code and resident application components.)

One or more system 200 elements can also be implemented in hardware, software or a suitable combination. When implemented in software (e.g. as an application program, object, downloadable, servlet, etc. in whole or part), a system 200 element can be communicated transitionally or more persistently from local or remote storage to

memory (or cache memory, etc.) for execution, or another suitable mechanism can be utilized, and elements can be implemented in compiled or interpretive form. Input, intermediate or resulting data or functional elements can further reside more transitionally or more persistently in a storage media, cache or more persistent volatile or non-volatile memory, (e.g. storage device 207 or memory 208) in accordance with a particular application.

FIG. 3 illustrates an interconnected re-communicator 300 generally consistent with system 140b of FIG. 1, according to an embodiment of the invention. As with system 140b, system 300 includes a server 301, and can also include a firewall 302. In this implementation, however, either server 301 or firewall 302 (if a firewall is used) can further include a protection engine (310 or 320 respectively). Thus, for example, an included firewall can process received information in a conventional manner, the results of which can be further processed by protection engine 310 of server 301, or information processed by protection engine 320 of an included firewall 302 can be processed in a conventional manner by server 301. (For clarity sake, a server including a singular protection engine will be presumed, with or without a firewall, for the remainder of the discussion unless otherwise indicated. Note, however, that other embodiments consistent with the teachings herein might also be utilized.)

FIG. 3 also shows how information received by server 301 (or firewall 302) can include non-executable information, executable information or a combination of non-executable and one or more executable code portions (e.g. so-called Trojan horses that include a hostile Downloadable within a friendly one, combined, compressed or otherwise encoded files, etc.). Particularly such combinations will likely remain

undetected by a firewall or other more conventional protection systems. Thus, for convenience, received information will also be referred to as a “potential-Downloadable”, and received information found to include executable code will be referred to as a “Downloadable” or equivalently as a “detected-Downloadable” (regardless of whether the executable code includes one or more application programs, distributable “components” such as Java, ActiveX, add-in, etc.).

Protection engine 310 provides for detecting whether received potential-Downloadables include executable code, and upon such detection, for causing mobile protection code (“MPC”) to be transferred to a device that is a destination of the potential-Downloadable (or “Downloadable-destination”). Protection engine 310 can also provide protection policies in conjunction with the MPC (or thereafter as well), which MPC/policies can be automatically (e.g. programmatically) or interactively configurable in accordance user, administrator, downloadable source, destination, operation, type or various other parameters alone or in combination (see below).

Protection engine 310 can also provide or operate separately or interoperably in conjunction with one or more of certification, authentication, downloadable tagging, source checking, verification, logging, diverting or other protection services via the MPC, policies, other local/remote server or destination processing, etc. (e.g. which can also include protection mechanisms taught by the above-noted prior applications; see FIG. 4).

Operationally, protection engine 310 of server 301 monitors information received by server 301 and determines whether the received information is deliverable to a protected destination, e.g. using a suitable monitor/data transfer mechanism and comparing a destination-address of the received information to a protected destination set,

such as a protected destinations list, array, database, etc. (All deliverable information or one or more subsets thereof might also be monitored.) Protection engine 310 further analyzes the potential-Downloadable and determines whether the potential-Downloadable includes executable code. If not, protection engine 310 enables the not executable potential-Downloadable 331 to be delivered to its destination in an unaffected manner.

In conjunction with determining that the potential-Downloadable is a detected-Downloadable, protection engine 310 also causes mobile protection code or "MPC" 341 to be communicated to the Downloadable-destination of the Downloadable, more suitably in conjunction with the detected-Downloadable 343 (see below). Protection engine 310 further causes downloadable protection policies 342 to be delivered to the Downloadable-destination, again more suitably in conjunction with the detected-Downloadable. Protection policies 342 provide parameters (or can additionally or alternatively provide additional mobile code) according to which the MPC is capable of determining or providing applicable protection to a Downloadable-destination against malicious Downloadable operations.

(One or more "checked", tag, source, destination, type, detection or other security result indicators, which are not shown, can also be provided as corresponding to determined non-Downloadables or Downloadables, e.g. for testing, logging, further processing, further identification tagging or other purposes in accordance with a particular application.)

Further MPCs, protection policies or other information are also deliverable to a the same or another destination, for example, in accordance with communication by an MPC/protection policies already delivered to a downloadable-destination. Initial or

subsequent MPCs/policies can further be selected or configured in accordance with a Downloadable-destination indicated by the detected-Downloadable, destination-user or administrative information, or other information providable to protection engine 310 by a user, administrator, user system, user system examination by a communicated MPC, etc.

5 (Thus, for example, an initial MPC/policies can also be initially provided that are operable with or optimized for more efficient operation with different Downloadable-destinations or destination capabilities.)

While integrated protection constraints within the MPC might also be utilized, providing separate protection policies has been found to be more efficient, for example, by enabling more specific protection constraints to be more easily updated in conjunction with detected-Downloadable specifics, post-download improvements, testing, etc. Separate policies can further be more efficiently provided (e.g. selected, modified, instantiated, etc.) with or separately from an MPC, or in accordance with the requirements of a particular user, device, system, administration, later improvement, etc., as might also be provided to protection engine 310 (e.g. via user/MPC uploading, querying, parsing a Downloadable, or other suitable mechanism implemented by one or more servers or Downloadable-destinations).

(It will also become apparent that performing executable code detection and communicating to a downloadable-Destination an MPC and any applicable policies as separate from a detected-Downloadable is more accurate and far less resource intensive than, for example, performing content and operation scanning, modifying a Downloadable, or providing completely Downloadable-destination based security.)

System 300 enables a single or extensible base-MPC to be provided, in anticipation or upon receipt of a first Downloadable, that is utilized thereafter to provide protection of one or more Downloadable-destinations. It is found, however, that providing an MPC upon each detection of a Downloadable (which is also enabled) can provide a desirable combination of configurability of the MPC/policies and lessened need for management (e.g. given potentially changing user/destination needs, enabling testing, etc.).

Providing an MPC upon each detection of a Downloadable also facilitates a lessened demand on destination resources, e.g. since information-destination resources used in executing the MPC/policies can be re-allocated following such use. Such alternatives can also be selectively, modifiably or extensibly provided (or further in accordance with other application-specific factors that might also apply.) Thus, for example, a base-MPC or base-policies might be provided to a user device that is/are extensible via additionally downloadable "modules" upon server 301 detection of a Downloadable deliverable to the same user device, among other alternatives.

In accordance with a further aspect of the invention, it is found that improved efficiency can also be achieved by causing the MPC to be executed within a Downloadable-destination in conjunction with, and further, prior to initiation of the detected Downloadable. One mechanism that provides for greater compatibility and efficiency in conjunction with conventional client-based Downloadable execution is for a protection engine to form a sandboxed package 340 including MPC 341, the detected-Downloadable 343 and any policies 342. For example, where the Downloadable is a binary executable to be executed by an operating system, protection engine 310 forms a

protected package by concatenating, within sandboxed package 340, MPC 341 for
 delivery to a Downloadable-destination first, followed by protection policies 342 and
 Downloadable 343. (Concatenation or techniques consistent therewith can also be
 utilized for providing a protecting package corresponding to a Java applet for execution
 5 by a JVM of a Downloadable-destination, or with regard to ActiveX controls, add-ins or
 other distributable components, etc.)

The above concatenation or other suitable processing will result in the following.
 Upon receipt of sandboxed package 340 by a compatible browser, email or other
 destination-client and activating of the package by a user or the destination-client, the
 10 operating system (or a suitable responsively initiated distributed component host) will
 attempt to initiate sandboxed package 340 as a single Downloadable. Such processing
 will, however, result in initiating the MPC 341 and -in accordance with further aspects of
 the invention- the MPC will initiate the Downloadable in a protected manner, further in
 accordance with any applicable included or further downloaded protection policies 342.
 15 (While system 300 is also capable of ascertaining protection policies stored at a
 Downloadable-destination, e.g. by poll, query, etc. of available destination information,
 including at least initial policies within a suitable protecting package is found to avoid
 associated security concerns or inefficiencies.)

Turning to FIG. 4, a protection engine 400 generally consistent with protection
 20 engine 310 (or 320) of FIG. 3 is illustrated in accordance with an embodiment of the
 invention. Protection engine 400 comprises information monitor 401, detection engine
 402, and protected packaging engine 403, which further includes agent generator 431,
 storage 404, linking engine 405, and transfer engine 406. Protection engine 400 can also

include a buffer 407, for temporarily storing a received potential-Downloadable, or one or more systems for conducting additional authentication, certification, verification or other security processing (e.g. summarily depicted as security system 408) Protection engine 400 can further provide for selectively re-directing, further directing, logging, etc. of a potential/detected Downloadable or information corresponding thereto in conjunction with detection, other security, etc., in accordance with a particular application.

(Note that FIG. 4, as with other figures included herein, also depicts exemplary signal flow arrows; such arrows are provided to facilitate discussion, and should not be construed as exclusive or otherwise limiting.)

Information monitor 401 monitors potential-Downloadables received by a host server and provides the information via buffer 407 to detection engine 402 or to other system 400 elements. Information monitor 401 can be configured to monitor host server download operations in conjunction with a user or a user-device that has logged-on to the server, or to receive information via a server operation hook, servlet, communication channel or other suitable mechanism.

Information monitor 401 can also provide for transferring, to storage 404 or other protection engine elements, configuration information including, for example, user, MPC, protection policy, interfacing or other configuration information (e.g. see FIG. 6). Such configuration information monitoring can be conducted in accordance with a user/device logging onto or otherwise accessing a host server, via one or more of configuration operations, using an applet to acquire such information from or for a particular user, device or devices, via MPC/policy polling of a user device, or via other suitable mechanisms.

Detection engine 402 includes code detector 421, which receives a potential-Downloadable and determines, more suitably in conjunction with inspection parameters 422, whether the potential-Downloadable includes executable code and is thus a “detected-Downloadable”. (Code detector 421 can also include detection processors for performing file decompression or other “decoding”, or such detection-facilitating processing as decryption, utilization/support of security system 408, etc. in accordance with a particular application.)

Detection engine 402 further transfers a detected-downloadable (“XEQ”) to protected packaging engine 403 along with indicators of such detection, or a determined non-executable (“NXEQ”) to transfer engine 406. (Inspection parameters 422 enable analysis criteria to be readily updated or varied, for example, in accordance with particular source, destination or other potential Downloadable impacting parameters, and are discussed in greater detail with reference to FIG. 5). Detection engine 402 can also provide indicators for delivery of initial and further MPCs/policies, for example, prior to or in conjunction with detecting a Downloadable and further upon receipt of an indicator from an already downloaded MPC/policy. A downloaded MPC/policy can further remain resident at a user device with further modules downloaded upon or even after delivery of a sandboxed package. Such distribution can also be provided in a configurable manner, such that delivery of a complete package or partial packages are automatically or interactively determinable in accordance with user/administrative preferences/policies, among other examples.

Packaging engine 403 provides for generating mobile protection code and protection policies, and for causing delivery thereof (typically with a detected-

Downloadable) to a Downloadable-destination for protecting the Downloadable-destination against malicious operation attempts by the detected Downloadable. In this example, packaging engine 403 includes agent generator 431, storage 404 and linking engine 405.

5 Agent generator 431 includes an MPC generator 432 and a protection policy generator 433 for “generating” an MPC and a protection policy (or set of policies) respectively upon receiving one or more “generate MPC/policy” indicators from detection engine 402, indicating that a potential-Downloadable is a detected-Downloadable. MPC generator 432 and protection policy generator 433 provide for generating MPCs and
 10 protection policies respectively in accordance with parameters retrieved from storage 404. Agent generator 431 is further capable of providing multiple MPCs/policies, for example, the same or different MPCs/policies in accordance with protecting ones of multiple executables within a zip file, or for providing initial MPCs/policies and then further MPCs/policies or MPC/policy “modules” as initiated by further indicators such as given
 15 above, via an indicator of an already downloaded MPC/policy or via other suitable mechanisms. (It will be appreciated that pre-constructed MPCs/policies or other processing can also be utilized, e.g. via retrieval from storage 404, but with a potential decrease in flexibility.)

MPC generator 432 and protection policy generator 433 are further configurable.
 20 Thus, for example, more generic MPCs/policies can be provided to all or a grouping of serviced destination-devices (e.g. in accordance with a similarly configured/administered intranet), or different MPCs/policies that can be configured in accordance with one or more of user, network administration, Downloadable-destination or other parameters (e.g.

see FIG. 6). As will become apparent, a resulting MPC provides an operational interface to a destination device/process. Thus, a high degree of flexibility and efficiency is enabled in providing such an operational interface within different or differently configurable user devices/processes or other constraints.

5 Such configurability further enables particular policies to be utilized in accordance with a particular application (e.g. particular system uses, access limitations, user interaction, treating application programs or Java components from a particular known source one way and unknown source ActiveX components, or other considerations). Agent generator 431 further transfers a resulting MPC and protection
10 policy pair to linking engine 405.

Linking engine 405 provides for forming from received component elements (see above) a sandboxed package that can include one or more initial or complete MPCs and applicable protection policies, and a Downloadable, such that the sandboxed package will protect a receiving Downloadable-destination from malicious operation by the
15 Downloadable. Linking engine 405 is implementable in a static or configurable manner in accordance, for example, with characteristics of a particular user device/process stored intermittently or more persistently in storage 404. Linking engine 405 can also provide for restoring a Downloadable, such as a compressed, encrypted or otherwise encoded file that has been decompressed, decrypted or otherwise decoded via detection processing
20 (e.g. see FIG. 6b).

It is discovered, for example, that the manner in which the Windows OS initiates a binary executable or an ActiveX control can be utilized to enable protected initiation of a detected-Downloadable. Linking engine 405 is, for example, configurable to form, for

an ordinary single-executable Downloadable (e.g. an application program, applet, etc.) a sandboxed package 340 as a concatenation of ordered elements including an MPC 341, applicable policies 342 and the Downloadable or "XEQ" 343 (e.g. see FIG. 4).

5 Linking engine 405 is also configurable to form, for a Downloadable received by a server as a compressed single or multiple-executable Downloadable such as a zipped or meta file, a protecting package 340 including one or more MPCs, applicable policies and the one or more included executables of the Downloadable. For example, a sandboxed package can be formed in which a single MPC and policies precede and thus will affect all such executables as a result of inflating and installation. An MPC and applicable policies can also, for example, precede each executable, such that each executable will be separately sandboxed in the same or a different manner according to MPC/policy configuration (see above) upon inflation and installation. (See also FIGS. 5 and 6)

10
15 Linking engine is also configurable to form an initial MPC, MPC-policy or sandboxed package (e.g. prior to upon receipt of a downloadable) or an additional MPC, MPC-policy or sandboxed package (e.g. upon or following receipt of a downloadable), such that suitable MPCs/policies can be provided to a Downloadable-destination or other destination in a more distributed manner. In this way, requisite bandwidth or destination resources can be minimized (via two or more smaller packages) in compromise with latency or other considerations raised by the additional required communication.

20 A configurable linking engine can also be utilized in accordance with other requirements of particular devices/processes, further or different elements or other permutations in accordance with the teachings herein. (It might, for example be desirable to modify the ordering of elements, to provide one or more elements separately, to

provide additional information, such as a header, etc., or perform other processing in accordance with a particular device, protocol or other application considerations.)

Policy/authentication reader-analyzer 481 summarily depicts other protection mechanisms that might be utilized in conjunction with Downloadable detection, such as
5 already discussed, and that can further be configurable to operate in accordance with policies or parameters (summarily depicted by security/authentication policies 482). Integration of such further protection in the depicted configuration, for example, enables a potential-Downloadable from a known unfriendly source, a source failing authentication or a provided-source that is confirmed to be fictitious to be summarily discarded,
10 otherwise blocked, flagged, etc. (with or without further processing). Conversely, a potential-Downloadable from a known friendly source (or one confirmed as such) can be transferred with or without further processing in accordance with particular application considerations. (Other configurations including pre or post Downloadable detection mechanisms might also be utilized.)

15 Finally, transfer engine 406 of protection agent engine 303 provides for receiving and causing linking engine 405 (or other protection) results to be transferred to a destination user device/process. As depicted, transfer engine 406 is configured to receive and transfer a Downloadable, a determined non-executable or a sandboxed package.

20 However, transfer engine 406 can also be provided in a more configurable manner, such as was already discussed for other system 400 elements. (Any one or more of system 400 elements might be configurably implemented in accordance with a particular application.) Transfer engine 406 can perform such transfer, for example, by adding the information to a server transfer queue (not shown) or utilizing another suitable method.

Turning to FIG. 5 with reference to FIG. 4, a code detector 421 example is illustrated in accordance with an embodiment of the invention. As shown, code detector 421 includes data fetcher 501, parser 502, file-type detector 503, inflater 504 and control 506; other depicted elements. While implementable and potentially useful in certain instances, are found to require substantial overhead, to be less accurate in certain instances (see above) and are not utilized in a present implementation; these will be discussed separately below. Code detector elements are further configurable in accordance with stored parameters retrievable by data fetcher 501. (A coupling between data fetcher 501 and control 506 has been removed for clarity sake.)

Data fetcher 501 provides for retrieving a potential-Downloadable or portions thereof stored in buffer 407 or parameters from storage 404, and communicates such information or parameters to parser 502. Parser 502 receives a potential-Downloadable or portions thereof from data fetcher 501 and isolates potential-Downloadable elements, such as file headers, source, destination, certificates, etc. for use by further processing elements.

File type detector 502 receives and determines whether the potential-Downloadable (likely) is or includes an executable file type. File-reader 502 can, for example, be configured to analyze a received potential-Downloadable for a file header, which is typically included in accordance with conventional data transfer protocols, such as a portable executable or standard “.exe” file format for Windows OS application programs, a Java class header for Java applets, and so on for other applications, distributed components, etc. “Zipped”, meta or other compressed files, which might include one or more executables, also typically provide standard single or multi-level

headers that can be read and used to identify included executable code (or other included information types). File type detector 502 is also configurable for analyzing potential-Downloadables for all potential file type delimiters or a more limited subset of potential file type delimiters (e.g. “.exe” or “.com” in conjunction with a DOS or Microsoft Windows OS Downloadable-destination).

Known file type delimiters can, for example, be stored in a more temporary or more persistent storage (e.g. storage 404 of FIG. 4) which file type detector 502 can compare to a received potential-Downloadable. (Such delimiters can thus also be updated in storage 404 as a new file type delimiter is provided, or a more limited subset of delimiters can also be utilized in accordance with a particular Downloadable-destination or other considerations of a particular application.) File type detector 502 further transfers to controller 506 a detected file type indicator indicating that the potential-Downloadable includes or does not include (i.e. or likely include) an executable file type.

In this example, the aforementioned detection processor is also included as pre-detection processor or, more particularly, a configurable file inflator 504. File inflator 504 provides for opening or “inflating” compressed files in accordance with a compressed file type received from file type detector 503 and corresponding file opening parameters received from data fetcher 501. Where a compressed file (e.g. a meta file) includes nested file type information not otherwise reliably provided in an overall file header or other information, inflator 504 returns such information to parser 502. File inflator 504 also provides any now-accessible included executables to control 506 where one or more included files are to be separately packaged with an MPC or policies.

Control 506, in this example, operates in accordance with stored parameters and provides for routing detected non-Downloadables or Downloadables and control information, and for conducting the aforementioned distributed downloading of packages to Downloadable-destinations. In the case of a non-Downloadable, for example, control 506 sends the non-Downloadable to transfer engine 406 (FIG. 4) along with any indicators that might apply. For an ordinary single-executable Downloadable, control 506 sends control information to agent generator 431 and the Downloadable to linking engine 405 along with any other applicable indicators (see 641 of FIG. 6b). Control 506 similarly handles a compressed single-executable Downloadable or a multiple downloadable to be protected using a single sandboxed package. For a multiple-executable Downloadable, control 506 sends control information for each corresponding executable to agent generator agent generator 431, and sends the executable to linking engine 405 along with controls and any applicable indicators, as in 643b of FIG. 6b. (The above assumes, however, that distributed downloading is not utilized; when used – according to applicable parameters- control 506 also operates in accordance with the following.)

Control 506 conducts distributed protection (e.g. distributed packaging) by providing control signals to agent generator 431, linking engine 405 and transfer engine 406. In the present example, control 506 initially sends controls to agent generator 431 and linking engine 405 (FIG. 4) causing agent generator to generate an initial MPC and initial policies, and sends control and a detected-Downloadable to linking engine 405. Linking engine 405 forms an initial sandboxed package, which transfer engine causes (in conjunction with further controls) to be downloaded to the Downloadable destination

(643a of FIG. 6b). An initial MPC within the sandboxed package includes an installer and a communicator and performs installation as indicated below. The initial MPC also communicates via the communicator controls to control 506 (FIG. 5) in response to which control 506 similarly causes generation of MPC-M and policy-M modules 643c, which linking engine 405 links and transfer engine 406 causes to be sent to the Downloadable destination, and so on for any further such modules.

(It will be appreciated, however, that an initial package might be otherwise configured or sent prior to receipt of a Downloadable in accordance with configuration parameters or user interaction. Information can also be sent to other user devices, such as that of an administrator. Further MPCs/policies might also be coordinated by control 506 or other elements, or other suitable mechanisms might be utilized in accordance with the teachings herein.)

Regarding the remaining detection engine elements illustrated in FIG. 5, where content analysis is utilized, parser 502 can also provide a Downloadable or portions thereof to content detector 505. Content detector 505 can then provide one or more content analyses. Binary detector 551, for example, performs detection of binary information; pattern detector 552 further analyzes the Downloadable for patterns indicating executable code, or other detectors can also be utilized. Analysis results therefrom can be used in an absolute manner, where a first testing result indicating executable code confirms Downloadable detection, which result is then sent to control 506. Alternatively, however, composite results from such analyses can also be sent to control 506 for evaluation. Control 506 can further conduct such evaluation in a summary manner (determining whether a Downloadable is detected according to a

majority or minimum number of indicators), or based on a weighting of different analysis results. Operation then continues as indicated above. (Such analysis can also be conducted in accordance with aspects of a destination user device or other parameters.)

FIG. 6a illustrates more specific examples of indicators/parameters and known (or
 5 “knowledge base”) elements that can be utilized to facilitate the above-discussed system
 400 configurability and detection. For clarity sake, indicators, parameters and knowledge
 base elements are combined as indicated “parameters.” It will be appreciated, however,
 that the particular parameters utilized can differ in accordance with a particular
 application, and indicators, parameters or known elements, where utilized, can vary and
 need not correspond exactly with one another. Any suitable explicit or referencing list,
 10 database or other storage structure(s) or storage structure configuration(s) can also be
 utilized to implement a suitable user/device based protection scheme, such as in the
 above examples, or other desired protection schema.

Executable parameters 601 comprise, in accordance with the above examples,
 15 executable file type parameters 611, executable code parameters 612 and code pattern
 parameters 613 (including known executable file type indicators, header/code indicators
 and patterns respectively, where code patterns are utilized). Use parameters 602 further
 comprise user parameters 621, system parameters 622 and general parameters 623
 corresponding to one or more users, user classifications, user-system correspondences or
 20 destination system, device or processes, etc. (e.g. for generating corresponding
 MPCs/policies, providing other protection, etc.). The remaining parameters include
 interface parameters 631 for providing MPC/policy (or further) configurability in

accordance with a particular device or for enabling communication with a device user (see below), and other parameters 632.

FIG. 6b illustrates a linking engine 405 according to an embodiment of the invention. As already discussed, linking engine 405 includes a linker for combining
 5 MPCs, policies or agents via concatenation or other suitable processing in accordance with an OS, JVM or other host executor or other applicable factors that might apply. Linking engine 405 also includes the aforementioned post-detection processor which, in this example, comprises a compressor 508. As noted, compressor 508 receives linked
 10 elements from linker 507 and, where a potential-Downloadable corresponds to a compressed file that was inflated during detection, re-forms the compressed file. (Known file information can be provided via configuration parameters, substantially reversal of inflating or another suitable method.) Encryption or other post-detection processing can also be conducted by linking engine 508.

FIGS. 7a, 7b and 8 illustrate a “sandbox protection” system, as operable within a
 15 receiving destination-device, according to an embodiment of the invention.

Beginning with FIG. 7a, a client 146 receiving sandbox package 340 will “recognize” sandbox package 340 as a (mobile) executable and cause a mobile code
 installer 711 (e.g. an OS loader, JVM, etc.) to be initiated. Mobile code installer 711 will also recognize sandbox package 340 as an executable and will attempt to initiate sandbox
 20 package 340 at its “beginning.” Protection engine 400 processing corresponding to destination 700 use of a such a loader, however, will have resulted in the “beginning” of sandbox package 340 as corresponding to the beginning of MPC 341, as noted with regard to the above FIG. 4 example.

Such protection engine processing will therefore cause a mobile code installer (e.g. OS loader 711, for clarity sake) to initiate MPC 341. In other cases, other processing might also be utilized for causing such initiation or further protection system operation. Protection engine processing also enables MPC 341 to effectively form a protection “sandbox” around Downloadable (e.g. detected-Downloadable or “XEQ”) 343, to monitor Downloadable 343, intercept determinable Downloadable 343 operation (such as attempted accesses of Downloadable 343 to destination resources) and, if “malicious”, to cause one or more other operations to occur (e.g. providing an alert, offloading the Downloadable, offloading the MPC, providing only limited resource access, possibly in a particular address space or with regard to a particularly “safe” resource or resource operation, etc.).

MPC 341, in the present OS example, executes MPC element installation and installs any policies, causing MPC 341 and protection policies 342 to be loaded into a first memory space, P1. MPC 341 then initiates loading of Downloadable 343. Such Downloadable initiation causes OS loader 711 to load Downloadable 343 into a further working memory space-P2 703 along with an API import table (“IAT”) 731 for providing Downloadable 631 with destination resource access capabilities. It is discovered, however that the IAT can be modified so that any call to an API can be redirected to a function within the MPC. The technique for modifying the IAT is documented within the MSDN (Microsoft Developers Network) Library CD in several articles. The technique is also different for each operating system (e.g. between Windows 9x and Windows NT), which can be accommodated by agent generator configurability, such as that given above.

MPC 341 therefore has at least initial access to API IAT 731 of Downloadable 632, and provides for diverting, evaluating and responding to attempts by Downloadable 632 to utilize system APIs 731, or further in accordance with protection policies 342.

In addition to API diverting, MPC 341 can also install filter drivers, which can be used
5 for controlling access to resources such as a Downloadable-destination file system or registry. Filter driver installation can be conducted as documented in the MSDN or using other suitable methods.

Turning to FIG. 8 with reference to FIG. 7b, an MPC 341 according to an embodiment of the invention includes a package extractor 801, executable installer 802,
10 sandbox engine installer 803, resource access diverter 804, resource access (attempt) analyzer 805, policy enforcer 806 and MPC de-installer 807. Package extractor 801 is initiated upon initiation of MPC 341, and extracts MPC 341 elements and protection policies 342. Executable installer 802 further initiates installation of a Downloadable by
15 extracting the downloadable from the protected package, and loading the process into memory in suspended mode (so it only loads into memory, but does not start to run). Such installation further causes the operating system to initialize the Downloadable's IAT 731 in the memory space of the downloadable process, P2, as already noted.

Sandbox engine installer 803 (running in process space P1) then installs the sandbox engine (803-805) and policies 342 into the downloadable process space P2. This
20 is done in different way in each operating system (e.g. see above). Resource access diverter 804 further modifies those Downloadable-API IAT entries that correspond with protection policies 342, thereby causing corresponding Downloadable accesses via Downloadable-API IAT 731 to be diverted resource access analyzer 805.

During Downloadable operation, resource access analyzer or “RAA” 805 receives and determines a response to diverted Downloadable (i.e. “malicious”) operations in accordance with corresponding protection policies of policies 342. (RAA 805 or further elements, which are not shown, can further similarly provide for other security mechanisms that might also be implemented.) Malicious operations can for example include, in a Windows environment: file operations (e.g. reading, writing, deleting or renaming a file), network operations (e.g. listen on or connect to a socket, send/receive data or view intranet), OS registry or similar operations (read/write a registry item), OS operations (exit OS/client, kill or change the priority of a process/thread, dynamically load a class library), resource usage thresholds (e.g. memory, CPU, graphics), etc.

Policy enforcer 806 receives RAA 805 results and causes a corresponding response to be implemented, again according to the corresponding policies. Policy enforcer 806 can, for example, interact with a user (e.g. provide an alert, receive instructions, etc.), create a log file, respond, cause a response to be transferred to the Downloadable using “dummy” or limited data, communicate with a server or other networked device (e.g. corresponding to a local or remote administrator), respond more specifically with a better known Downloadable, verify accessibility or user/system information (e.g. via local or remote information), even enable the attempted Downloadable access, among a wide variety of responses that will become apparent in view of the teachings herein.

The FIG. 9 flowchart illustrates a protection method according to an embodiment of the invention. In step 901, a protection engine monitors the receipt, by a server or other re-communicator of information, and receives such information intended for a

protected information-destination (i.e. a potential-Downloadable) in step 903. Steps 905-911 depict an adjunct trustworthiness protection that can also be provided, wherein the protection engine determines whether the source of the received information is known to be “unfriendly” and, if so, prevents current (at least unaltered) delivery of the potential-Downloadable and provides any suitable alerts. (The protection engine might also continue to perform Downloadable detection and nevertheless enable delivery or protected delivery of a non-Downloadable, or avoid detection if the source is found to be “trusted”, among other alternatives enabled by the teachings herein.)

FIG. 10a
10 If, in step 913, the potential-Downloadable source is found to be of an unknown or otherwise suitably authenticated/certified source, then the protection engine determines whether the potential-Downloadable includes executable code in step 915. If the potential-Downloadable does not include executable code, then the protection engine causes the potential-Downloadable to be delivered to the information-destination in its original form in step 917, and the method ends. If instead the potential-Downloadable is
15 found to include executable code in step 915 (and is thus a “detected-Downloadable”), then the protection engine forms a sandboxed package in step 919 and causes the protection agent to be delivered to the information-Destination in step 921, and the method ends. As was discussed earlier, a suitable protection agent can include mobile protection code, policies and the detected-Downloadable (or information corresponding
20 thereto).

The FIG. 10a flowchart illustrates a method for analyzing a potential-Downloadable, according to an embodiment of the invention. As shown, one or more aspects can provide useful indicators of the inclusion of executable code within the

potential-Downloadable. In step 1001, the protection engine determines whether the potential-Downloadable indicates an executable file type, for example, by comparing one or more included file headers for file type indicators (e.g. extensions or other descriptors). The indicators can be compared against all known file types executable by all protected Downloadable destinations, a subset, in accordance with file types executable or desirably executable by the Downloadable-destination, in conjunction with a particular user, in conjunction with available information or operability at the destination, various combinations, etc.

Where content analysis is conducted, in step 1003 of FIG. 10a, the protection engine analyzes the potential-Downloadable and determines in accordance therewith whether the potential-Downloadable does or is likely to include binary information, which typically indicates executable code. The protection engine further analyzes the potential-Downloadable for patterns indicative of included executable code in step 1003. Finally, in step 1005, the protection engine determines whether the results of steps 1001 and 1003 indicate that the potential-Downloadable more likely includes executable code (e.g. via weighted comparison of the results with a suitable level indicating the inclusion or exclusion of executable code). The protection engine, given a suitably high confidence indicator of the inclusion of executable code, treats the potential-Downloadable as a detected-Downloadable.

The FIG. 10b flowchart illustrates a method for forming a sandboxed package according to an embodiment of the invention. As shown, in step 1011, a protection engine retrieves protection parameters and forms mobile protection code according to the parameters. The protection engine further, in step 1013, retrieves protection parameters

and forms protection policies according to the parameters. Finally, in step 1015, the protection engine couples the mobile protection code, protection policies and received-information to form a sandboxed package. For example, where a Downloadable-destination utilizes a standard windows executable, coupling can further be accomplished via concatenating the MPC for delivery of MPC first, policies second, and received information third. (The protection parameters can, for example, include parameters relating to one or more of the Downloadable destination device/process, user, supervisory constraints or other parameters.)

10 The FIG. 11 flowchart illustrates how a protection method performed by mobile protection code ("MPC") according to an embodiment of the invention includes the MPC installing MPC elements and policies within a destination device in step 1101. In step 1102, the MPC loads the Downloadable without actually initiating it (i.e. for executables, it will start a process in suspended mode). The MPC further forms an access monitor or "interceptor" for monitoring or "intercepting" downloadable destination device access attempts within the destination device (according to the protection policies in step 1103, and initiates a corresponding Downloadable within the destination device in step 1105.

15 If, in step 1107, the MPC determines, from monitored/intercepted information, that the Downloadable is attempting or has attempted a destination device access considered undesirable or otherwise malicious, then the MPC performs steps 1109 and 20 1111; otherwise the MPC returns to step 1107. In step 1109, the MPC determines protection policies in accordance with the access attempt by the Downloadable, and in step 1111, the MPC executes the protection policies. (Protection policies can, for example, be retrieved from a temporary, e.g. memory/cache, or more persistent storage.)

As shown in the FIG. 12a example, the MPC can provide for intercepting Downloadable access attempts by a Downloadable by installing the Downloadable (but not executing it) in step 1201. Such installation will cause a Downloadable executor, such as a the Windows operating system, to provide all required interfaces and parameters (such as the IAT, process ID, etc.) for use by the Downloadable to access device resources of the host device. The MPC can thus cause Downloadable access attempts to be diverted to the MPC by modifying the Downloadable IAT, replacing device resource location indicators with those of the MPC (step 1203).

The FIG. 12b example further illustrates an example of how the MPC can apply suitable policies in accordance with an access attempt by a Downloadable. As shown, the MPC receives the Downloadable access request via the modified IAT in step 1211. The MPC further queries stored policies to determine a policy corresponding to the Downloadable access request in step 1213.

The foregoing description of preferred embodiments of the invention is provided by way of example to enable a person skilled in the art to make and use the invention, and in the context of particular applications and requirements thereof. Various modifications to the embodiments will be readily apparent to those skilled in the art, and the generic principles defined herein may be applied to other embodiments and applications without departing from the spirit and scope of the invention. Thus, the present invention is not intended to be limited to the embodiments shown, but is to be accorded the widest scope consistent with the principles, features and teachings disclosed herein. The embodiments described herein are not intended to be exhaustive or limiting. The present invention is limited only by the following claims.

WHAT IS CLAIMED IS:

1. A method, comprising:

receiving downloadable-information;

determining whether the downloadable-information includes executable code; and

5 causing mobile protection code to be communicated to at least one information-destination of the downloadable-information, if the downloadable-information is determined to include executable code.

2. The method of claim 1, wherein the receiving includes monitoring received information of an information re-communicator.

3. The method of claim 2, wherein the information re-communicator is a network server.

4. The method of claim 1, wherein the determining comprises analyzing the
15 downloadable-information for an included type indicator indicating an executable file type.

5. The method of claim 1, wherein the determining comprises analyzing the
downloadable-information for an included an included type detector indicating an archive
20 file that contains at least one executable.

6. The method of claim 1, wherein the determining comprises analyzing the
downloadable-information for an included file type indicator and an information pattern

FILED IN REPLY TO 622990
 10
 15

corresponding to one or more information patterns that tend to be included within executable code.

7. The method of claim 1, further comprising receiving one or more executable code characteristics of executable code that is capable of being executed by the information-destination, and wherein the determining is conducted in accordance with the executable code characteristics.

8. The method of claim 1, wherein the determining comprises performing one or more analyses of the downloadable-information, the analyses producing detection-indicators indicating whether a correspondence is detected between a downloadable-information characteristic and at least one respective executable code characteristic, and evaluating the detection-indicators to determine whether the downloadable-information includes executable code.

9. The method of claim 8, wherein at least one of the detection-indicators indicates a level of downloadable-information characteristic and executable code characteristic correspondence.

10. The method of claim 8, wherein the evaluating includes assigning a weighted level of importance to at least one of the indicators.

11. The method of claim 1, wherein the causing mobile protection code to be

10
15
20

communicated comprises forming a sandboxed package including the mobile protection code and the downloadable-information, and causing the sandboxed package to be communicated to the at least one information-destination.

5 12. The method of claim 10, wherein the sandboxed package is formed such that the mobile protection code will be executed by the information-destination before the downloadable-information.

13. The method of claim 11, wherein the sandboxed package further includes protection policies according to which the mobile protection code is operable.

14. The method of claim 13, wherein the sandboxed package is formed for receipt by the information-destination such that the mobile protection code is received before the downloadable-information, and the downloadable information before the protection policies.

15 15. The method of claim 13, wherein the protection policies correspond with at least one of the information-destination and a user of the information destination.

20 16. A system, comprising:

an information monitor for receiving downloadable-information;

a content inspection engine communicatively coupled to the information monitor

for determining whether the downloadable-information includes executable code; and

FILED FOR REGISTRATION

a protection agent engine communicatively coupled to the content inspection engine for causing mobile protection code (“MPC”) to be communicated to at least one information-destination of the downloadable-information, if the downloadable-information is determined to include executable code.

5

17. The system of claim 16, wherein the information monitor intercepts received information received by an information re-communicator.

18. The system of claim 17, wherein the information re-communicator is a network server.

10

19. The system of claim 16, wherein the content inspection engine comprises a file type detector for determining whether the downloadable-information includes a file type indicator indicating an executable file type.

15

20. The system of claim 16, wherein the content inspection engine comprises a parser for parsing the downloadable-information and a content analyzer communicatively coupled to the parser for determining whether one or more downloadable-information elements of the downloadable-information correspond with executable code elements are executable code elements.

20

21. The system of claim 16, wherein the content inspection engine comprises one or more downloadable-information analyzers for analyzing the downloadable-information,

each analyzer producing therefrom a detection indicator indicating whether a
downloadable-information characteristic corresponds with an executable code
characteristic, and an inspection controller communicatively coupled to the analyzers for
determining whether the indicators indicate that the downloadable-information includes
5 executable code.

22. The system of claim 21, wherein at least one of the detection-indicators indicates a
level of downloadable-information characteristic and executable code characteristic
correspondence.

23. The system of claim 21, wherein the evaluating includes assigning a weighted level
of importance to at least one of the detection-indicators.

24. The system of claim 16, wherein the sandboxed package engine comprises an MPC
generator for providing the MPC, a linking engine coupled to the MPC generator for
forming a protection agent including the MPC and the downloadable-information, and a
transfer engine for causing the protection agent to be communicated to the at least one
information-destination.

20 25. The system of claim 24, wherein the protection agent engine further comprises a
policy generator communicatively coupled to the linking engine for providing protection
policies according to which the MPC is operable.

26. The system of claim 25, wherein the sandboxed package is formed for receipt by the information-destination such that the mobile protection code is executed before the downloadable-information.

5 27. The system of claim 26, wherein the protection policies correspond with policies of at least one of the information-destination and a user of the information destination.

28. A system, comprising:

means for receiving downloadable-information;

10 means for determining whether the downloadable-information includes executable code; and

means for causing mobile protection code to be communicated to at least one information-destination of the downloadable-information, if the downloadable-information is determined to include executable code.

15 29. A computer-readable storage medium storing program code for causing a computer to perform the steps of:

receiving downloadable-information;

determining whether the downloadable-information includes executable code; and

20 causing mobile protection code to be communicated to at least one information-destination of the downloadable-information, if the downloadable-information is determined to include executable code.

THE COURT REPORTERS

30. A method, comprising:

receiving, at an information re-communicator, downloadable-information,

including executable code; and

causing mobile protection code to be executed by a mobile code executor at a

5 downloadable-information destination such that one or more operations of the executable code at the destination, if attempted, will be processed by the mobile protection code.

31. The method of claim 30, wherein the mobile code executor is a Java Virtual Machine.

32. The method of claim 30, wherein the mobile code executor is the operating system, running native code executables.

33. The method of claim 30, wherein the mobile code executor is ActiveX subsystem of the windows operating system

34. The method of claim 30, wherein the mobile code executor is the Microsoft Windows scripting host

20 35. The method of claim 30, wherein the causing is accomplished by forming a sandboxed package including the mobile protection code and the downloadable-information, and causing the sandboxed package to be delivered to the downloadable-information destination.

FOR FURTHER INFORMATION

36. The method of claim 35, wherein the sandboxed package further includes protection policies according to which the processing by the mobile protection code is conducted.

5 37. A sandboxed package formed according to the method of claim 35.

38. A sandboxed package formed according to the method of claim 36.

39. The method of claim 36, wherein the forming comprises generating the mobile protection code, generating the sandboxed package, and linking the mobile protection code, protection policies and downloadable-information.

40. The method of claim 39, wherein the generating of at least one of the mobile protection code and the protection policies is conducted in accordance with one or more destination-characteristics of the destination.

41. The method of claim 40, wherein the destination-characteristics include characteristics corresponding to at least one of a destination user, a destination device and a destination process.

42. The method of claim 35, wherein the causing the sandboxed package to be executed includes communicating the sandboxed package to a communication buffer of the information re-communicator.

10
15
20
25
30
35
40
45
50
55
60
65
70
75
80
85
90
95
100

43. The method of claim 30, wherein the re-communicator is at least one of a firewall and a network server.

5 44. The method of claim 30, wherein the sandboxed package has a same file type as the downloadable-information, thereby causing the mobile code executor to be unaware that the protected package is not a normal downloadable.

10 45. The method of claim 44, wherein the sandboxed package is formed using concatenation of a mobile protection code, a policy, and a downloadable.

15 46. The method of claim 30, wherein executing the mobile protection code at the destination causes downloadable interfaces to resources at the destination to be modified such that at least one attempted operation of the executable code is diverted to the mobile protection code.

47. A system, comprising:

receiving means for receiving, at an information re-communicator, downloadable-information, including executable code; and

20 mobile code means communicatively coupled to the receiving means for causing mobile protection code to be executed by a mobile code executor at a downloadable-information destination such that one or more operations of the executable code at the destination, if attempted, will be processed by the mobile protection code.

FOR THE "BEST COPY"

48. The system of claim 47, wherein the mobile code executor is a Java Virtual Machine.

49. The system of claim 47, wherein the mobile code executor is an operating system,

5 running native code executables.

50. The system of claim 47, wherein the mobile code executor is an ActiveX subsystem of the windows operating system.

10 51. The system of claim 47, wherein the mobile code executor is a Microsoft Windows scripting host.

15 52. The system of claim 47, wherein the causing is accomplished by forming a sandboxed package including the mobile protection code and the downloadable-information, and causing the sandboxed package to be delivered to the downloadable-information destination.

53. The system of claim 52, wherein the sandboxed package further includes protection policies according to which the processing by the mobile protection code is conducted.

20

54. The system of claim 53, wherein the forming comprises generating the mobile protection code, generating the protection policies, and linking the mobile protection code, protection policies and downloadable-information.

FILED OCT 20 2009

55. The system of claim 54, wherein the generating of at least one of the mobile protection code and the protection policies is conducted in accordance with one or more destination-characteristics of the destination.

5

56. The system of claim 55, wherein the destination-characteristics include characteristics corresponding to at least one of a destination user, a destination device and a destination process.

57. The system of claim 46, wherein the causing the sandboxed package to be executed includes communicating the sandboxed package to a communication buffer of the information re-communicator.

58. The system of claim 47, wherein the re-communicator is at least one of a firewall and a network server.

59. The system of claim 47, wherein executing the mobile protection code at the destination causes downloadable interfaces a resource at the destination to be modified such that at least one attempted operation of the executable code is diverted to the mobile protection code.

60. A computer-readable storage medium storing program code for causing a computer to perform the steps of:

FOR FILING
10
15
20

receiving, at an information re-communicator, downloadable-information,
including executable code; and

causing mobile protection code to be executed by a mobile code executor at a
downloadable-information destination such that one or more operations of the executable
5 code at the destination, if attempted, will be processed by the mobile protection code.

61. A method, comprising:

receiving mobile protection code (“MPC”) and a Downloadable at a
Downloadable-destination;

10 causing, by the MPC, one or more operations attempted by the Downloadable to
be received by the MPC;

receiving, by the MPC, an attempted operation of the Downloadable; and

15 initiating, by the MPC, a protection policy corresponding to the attempted
operation.

62. The method of claim 61, wherein the receiving comprises receiving a sandboxed
package that includes the MPC, the Downloadable and one or more protection policies.

20 63. The method of claim 62, wherein the sandboxed package is configured such that the
MPC is executed first, the Downloadable is executed by the MPC and the protection
policies are accessible to the MPC.

64. The method of claim 61, wherein the causing comprises modifying, by the MPC,

FOR FILING

interfaces of a corresponding downloadable to resources at the destination.

65. The method of claim 64, wherein the modifying is accomplished by initiating a loading of the Downloadable, thereby causing a mobile code executor to provide and initialize the interfaces, modifying one or more interface elements to divert corresponding attempted Downloadable operations to the MPC, and initiating execution of the Downloadable.

66. The method of claim 64, wherein the interfaces comprise an import address table ("IAT") of a native code executable downloadable.

67. The method of claim 64, wherein modifying the interfaces installs a filter-driver between the downloadable and the resources.

68. A system, comprising:

a mobile code executor for initiating received mobile code; and

a sandboxed package capable of being received and initiated by the mobile code executor, the sandboxed package including a Downloadable and mobile protection code ("MPC") for causing one or more Downloadable operations to be intercepted and for processing the intercepted operations, if the Downloadable attempts to initiate the operations.

69. The system of claim 60, wherein the MPC comprises:

TOP SECRET

an MPC installer for causing MPC elements to be installed;

a Downloadable installer communicatively coupled to the MPC element installer for installing the Downloadable;

5 a resource access diverter communicatively coupled to the MPC installer for causing the Downloadable operations to be intercepted;

a resource access analyzer communicatively coupled to the MPC installer for receiving an intercepted Downloadable operation and determining a protection policy corresponding to the intercepted Downloadable operation; and

10 a policy enforcer communicatively coupled to the resource access analyzer for processing the intercepted Downloadable operation.

70. The system of claim 69, wherein the resource access diverter modifies one or more elements of an interface usable by the Downloadable to effectuate the Downloadable operations.

71. The system of claim 69, wherein the mobile code executor is a Java Virtual Machine.

72. The system of claim 69, wherein the mobile code executor is an operating system, running native code executables.

20 73. The system of claim 69, wherein the mobile code executor is an ActiveX subsystem of the windows operating system.

100
 110
 120
 130
 140
 150
 160
 170
 180
 190
 200
 210
 220
 230
 240
 250
 260
 270
 280
 290
 300
 310
 320
 330
 340
 350
 360
 370
 380
 390
 400
 410
 420
 430
 440
 450
 460
 470
 480
 490
 500
 510
 520
 530
 540
 550
 560
 570
 580
 590
 600
 610
 620
 630
 640
 650
 660
 670
 680
 690
 700
 710
 720
 730
 740
 750
 760
 770
 780
 790
 800
 810
 820
 830
 840
 850
 860
 870
 880
 890
 900
 910
 920
 930
 940
 950
 960
 970
 980
 990
 1000
 1010
 1020
 1030
 1040
 1050
 1060
 1070
 1080
 1090
 1100
 1110
 1120
 1130
 1140
 1150
 1160
 1170
 1180
 1190
 1200
 1210
 1220
 1230
 1240
 1250
 1260
 1270
 1280
 1290
 1300
 1310
 1320
 1330
 1340
 1350
 1360
 1370
 1380
 1390
 1400
 1410
 1420
 1430
 1440
 1450
 1460
 1470
 1480
 1490
 1500
 1510
 1520
 1530
 1540
 1550
 1560
 1570
 1580
 1590
 1600
 1610
 1620
 1630
 1640
 1650
 1660
 1670
 1680
 1690
 1700
 1710
 1720
 1730
 1740
 1750
 1760
 1770
 1780
 1790
 1800
 1810
 1820
 1830
 1840
 1850
 1860
 1870
 1880
 1890
 1900
 1910
 1920
 1930
 1940
 1950
 1960
 1970
 1980
 1990
 2000
 2010
 2020
 2030
 2040
 2050
 2060
 2070
 2080
 2090
 2100
 2110
 2120
 2130
 2140
 2150
 2160
 2170
 2180
 2190
 2200
 2210
 2220
 2230
 2240
 2250
 2260
 2270
 2280
 2290
 2300
 2310
 2320
 2330
 2340
 2350
 2360
 2370
 2380
 2390
 2400
 2410
 2420
 2430
 2440
 2450
 2460
 2470
 2480
 2490
 2500
 2510
 2520
 2530
 2540
 2550
 2560
 2570
 2580
 2590
 2600
 2610
 2620
 2630
 2640
 2650
 2660
 2670
 2680
 2690
 2700
 2710
 2720
 2730
 2740
 2750
 2760
 2770
 2780
 2790
 2800
 2810
 2820
 2830
 2840
 2850
 2860
 2870
 2880
 2890
 2900
 2910
 2920
 2930
 2940
 2950
 2960
 2970
 2980
 2990
 3000
 3010
 3020
 3030
 3040
 3050
 3060
 3070
 3080
 3090
 3100
 3110
 3120
 3130
 3140
 3150
 3160
 3170
 3180
 3190
 3200
 3210
 3220
 3230
 3240
 3250
 3260
 3270
 3280
 3290
 3300
 3310
 3320
 3330
 3340
 3350
 3360
 3370
 3380
 3390
 3400
 3410
 3420
 3430
 3440
 3450
 3460
 3470
 3480
 3490
 3500
 3510
 3520
 3530
 3540
 3550
 3560
 3570
 3580
 3590
 3600
 3610
 3620
 3630
 3640
 3650
 3660
 3670
 3680
 3690
 3700
 3710
 3720
 3730
 3740
 3750
 3760
 3770
 3780
 3790
 3800
 3810
 3820
 3830
 3840
 3850
 3860
 3870
 3880
 3890
 3900
 3910
 3920
 3930
 3940
 3950
 3960
 3970
 3980
 3990
 4000
 4010
 4020
 4030
 4040
 4050
 4060
 4070
 4080
 4090
 4100
 4110
 4120
 4130
 4140
 4150
 4160
 4170
 4180
 4190
 4200
 4210
 4220
 4230
 4240
 4250
 4260
 4270
 4280
 4290
 4300
 4310
 4320
 4330
 4340
 4350
 4360
 4370
 4380
 4390
 4400
 4410
 4420
 4430
 4440
 4450
 4460
 4470
 4480
 4490
 4500
 4510
 4520
 4530
 4540
 4550
 4560
 4570
 4580
 4590
 4600
 4610
 4620
 4630
 4640
 4650
 4660
 4670
 4680
 4690
 4700
 4710
 4720
 4730
 4740
 4750
 4760
 4770
 4780
 4790
 4800
 4810
 4820
 4830
 4840
 4850
 4860
 4870
 4880
 4890
 4900
 4910
 4920
 4930
 4940
 4950
 4960
 4970
 4980
 4990
 5000
 5010
 5020
 5030
 5040
 5050
 5060
 5070
 5080
 5090
 5100
 5110
 5120
 5130
 5140
 5150
 5160
 5170
 5180
 5190
 5200
 5210
 5220
 5230
 5240
 5250
 5260
 5270
 5280
 5290
 5300
 5310
 5320
 5330
 5340
 5350
 5360
 5370
 5380
 5390
 5400
 5410
 5420
 5430
 5440
 5450
 5460
 5470
 5480
 5490
 5500
 5510
 5520
 5530
 5540
 5550
 5560
 5570
 5580
 5590
 5600
 5610
 5620
 5630
 5640
 5650
 5660
 5670
 5680
 5690
 5700
 5710
 5720
 5730
 5740
 5750
 5760
 5770
 5780
 5790
 5800
 5810
 5820
 5830
 5840
 5850
 5860
 5870
 5880
 5890
 5900
 5910
 5920
 5930
 5940
 5950
 5960
 5970
 5980
 5990
 6000
 6010
 6020
 6030
 6040
 6050
 6060
 6070
 6080
 6090
 6100
 6110
 6120
 6130
 6140
 6150
 6160
 6170
 6180
 6190
 6200
 6210
 6220
 6230
 6240
 6250
 6260
 6270
 6280
 6290
 6300
 6310
 6320
 6330
 6340
 6350
 6360
 6370
 6380
 6390
 6400
 6410
 6420
 6430
 6440
 6450
 6460
 6470
 6480
 6490
 6500
 6510
 6520
 6530
 6540
 6550
 6560
 6570
 6580
 6590
 6600
 6610
 6620
 6630
 6640
 6650
 6660
 6670
 6680
 6690
 6700
 6710
 6720
 6730
 6740
 6750
 6760
 6770
 6780
 6790
 6800
 6810
 6820
 6830
 6840
 6850
 6860
 6870
 6880
 6890
 6900
 6910
 6920
 6930
 6940
 6950
 6960
 6970
 6980
 6990
 7000
 7010
 7020
 7030
 7040
 7050
 7060
 7070
 7080
 7090
 7100
 7110
 7120
 7130
 7140
 7150
 7160
 7170
 7180
 7190
 7200
 7210
 7220
 7230
 7240
 7250
 7260
 7270
 7280
 7290
 7300
 7310
 7320
 7330
 7340
 7350
 7360
 7370
 7380
 7390
 7400
 7410
 7420
 7430
 7440
 7450
 7460
 7470
 7480
 7490
 7500
 7510
 7520
 7530
 7540
 7550
 7560
 7570
 7580
 7590
 7600
 7610
 7620
 7630
 7640
 7650
 7660
 7670
 7680
 7690
 7700
 7710
 7720
 7730
 7740
 7750
 7760
 7770
 7780
 7790
 7800
 7810
 7820
 7830
 7840
 7850
 7860
 7870
 7880
 7890
 7900
 7910
 7920
 7930
 7940
 7950
 7960
 7970
 7980
 7990
 8000
 8010
 8020
 8030
 8040
 8050
 8060
 8070
 8080
 8090
 8100
 8110
 8120
 8130
 8140
 8150
 8160
 8170
 8180
 8190
 8200
 8210
 8220
 8230
 8240
 8250
 8260
 8270
 8280
 8290
 8300
 8310
 8320
 8330
 8340
 8350
 8360
 8370
 8380
 8390
 8400
 8410
 8420
 8430
 8440
 8450
 8460
 8470
 8480
 8490
 8500
 8510
 8520
 8530
 8540
 8550
 8560
 8570
 8580
 8590
 8600
 8610
 8620
 8630
 8640
 8650
 8660
 8670
 8680
 8690
 8700
 8710
 8720
 8730
 8740
 8750
 8760
 8770
 8780
 8790
 8800
 8810
 8820
 8830
 8840
 8850
 8860
 8870
 8880
 8890
 8900
 8910
 8920
 8930
 8940
 8950
 8960
 8970
 8980
 8990
 9000
 9010
 9020
 9030
 9040
 9050
 9060
 9070
 9080
 9090
 9100
 9110
 9120
 9130
 9140
 9150
 9160
 9170
 9180
 9190
 9200
 9210
 9220
 9230
 9240
 9250
 9260
 9270
 9280
 9290
 9300
 9310
 9320
 9330
 9340
 9350
 9360
 9370
 9380
 9390
 9400
 9410
 9420
 9430
 9440
 9450
 9460
 9470
 9480
 9490
 9500
 9510
 9520
 9530
 9540
 9550
 9560
 9570
 9580
 9590
 9600
 9610
 9620
 9630
 9640
 9650
 9660
 9670
 9680
 9690
 9700
 9710
 9720
 9730
 9740
 9750
 9760
 9770
 9780
 9790
 9800
 9810
 9820
 9830
 9840
 9850
 9860
 9870
 9880
 9890
 9900
 9910
 9920
 9930
 9940
 9950
 9960
 9970
 9980
 9990
 10000
 10010
 10020
 10030
 10040
 10050
 10060
 10070
 10080
 10090
 10100
 10110
 10120
 10130
 10140
 10150
 10160
 10170
 10180
 10190
 10200
 10210
 10220
 10230
 10240
 10250
 10260
 10270
 10280
 10290
 10300
 10310
 10320
 10330
 10340
 10350
 10360
 10370
 10380
 10390
 10400
 10410
 10420
 10430
 10440
 10450
 10460
 10470
 10480
 10490
 10500
 10510
 10520
 10530
 10540
 10550
 10560
 10570
 10580
 10590
 10600
 10610
 10620
 10630
 10640
 10650
 10660
 10670
 10680
 10690
 10700
 10710
 10720
 10730
 10740
 10750
 10760
 10770
 10780
 10790
 10800
 10810
 10820
 10830
 10840
 10850
 10860
 10870
 10880
 10890
 10900
 10910
 10920
 10930
 10940
 10950
 10960
 10970
 10980
 10990
 11000

74. The system of claim 69, wherein the mobile code executor is an Microsoft Windows scripting host.

75. A system, comprising

5 receiving means for receiving mobile protection code (“MPC”) and a

Downloadable at a Downloadable-destination;

monitoring means for causing, by the MPC, one or more operations attempted by
the Downloadable to be received by the MPC;

second receiving means receiving, by the MPC, an attempted operation of the
Downloadable; and

initiating means for initiating, by the MPC, a protection policy corresponding to
the attempted operation.

76. A computer-readable storage medium storing program code for causing a computer
15 to perform the steps of:

receiving mobile protection code (“MPC”) and a Downloadable at a
Downloadable-destination;

causing, by the MPC, one or more operations attempted by the Downloadable to
be received by the MPC;

20 receiving, by the MPC, an attempted operation of the Downloadable; and

initiating, by the MPC, a protection policy corresponding to the attempted
operation.

FILED FOR CASE 1:14-cv-00014

ABSTRACT OF THE DISCLOSURE

MALICIOUS MOBILE CODE RUNTIME MONITORING

SYSTEM AND METHODS

5

Protection systems and methods provide for protecting one or more personal computers (“PCs”) and/or other intermittently or persistently network accessible devices or processes from undesirable or otherwise malicious operations of Java™ applets, ActiveX™ controls, JavaScript™ scripts, Visual Basic scripts, add-ins, downloaded/ uploaded programs or other “Downloadables” or “mobile code” in whole or part. A protection engine embodiment provides, within a server, firewall or other suitable “re-communicator,” for monitoring information received by the communicator, determining whether received information does or is likely to include executable code, and if so, causes mobile protection code (MPC) to be transferred to and rendered operable within a destination device of the received information, more suitably by forming a protection agent including the MPC, protection policies and a detected-Downloadable. An MPC embodiment further provides, within a Downloadable-destination, for initiating the Downloadable, enabling malicious Downloadable operation attempts to be received by the MPC, and causing (predetermined) corresponding operations to be executed in response to the attempts, more suitably in conjunction with protection policies.

10
15
20
FOR THE COURT

100

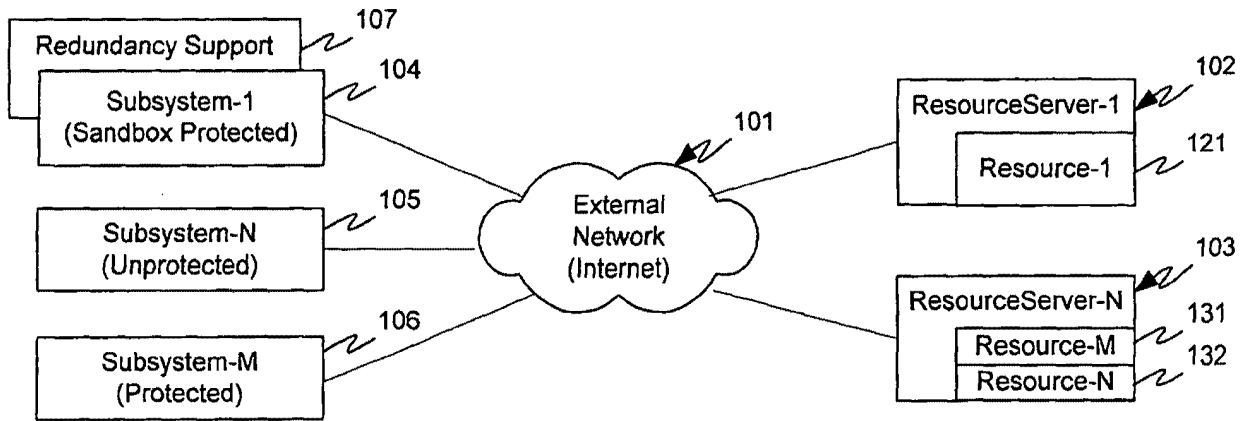

FIG. 1a

104a

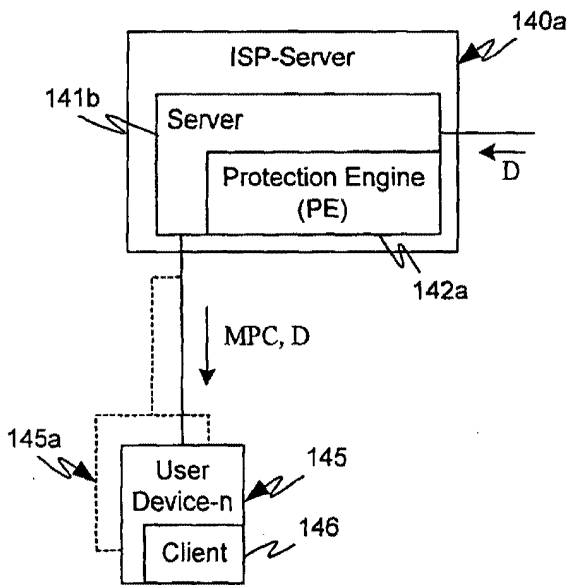

FIG. 1b

104b

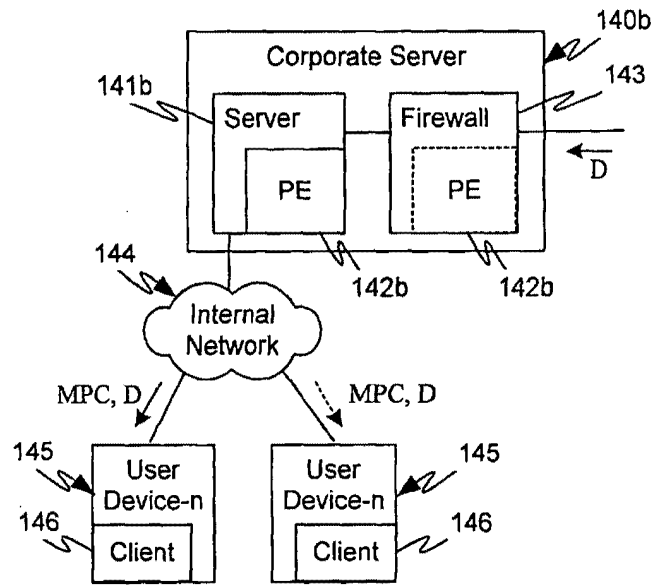

FIG. 1c

Downloaded from ascelibrary.org

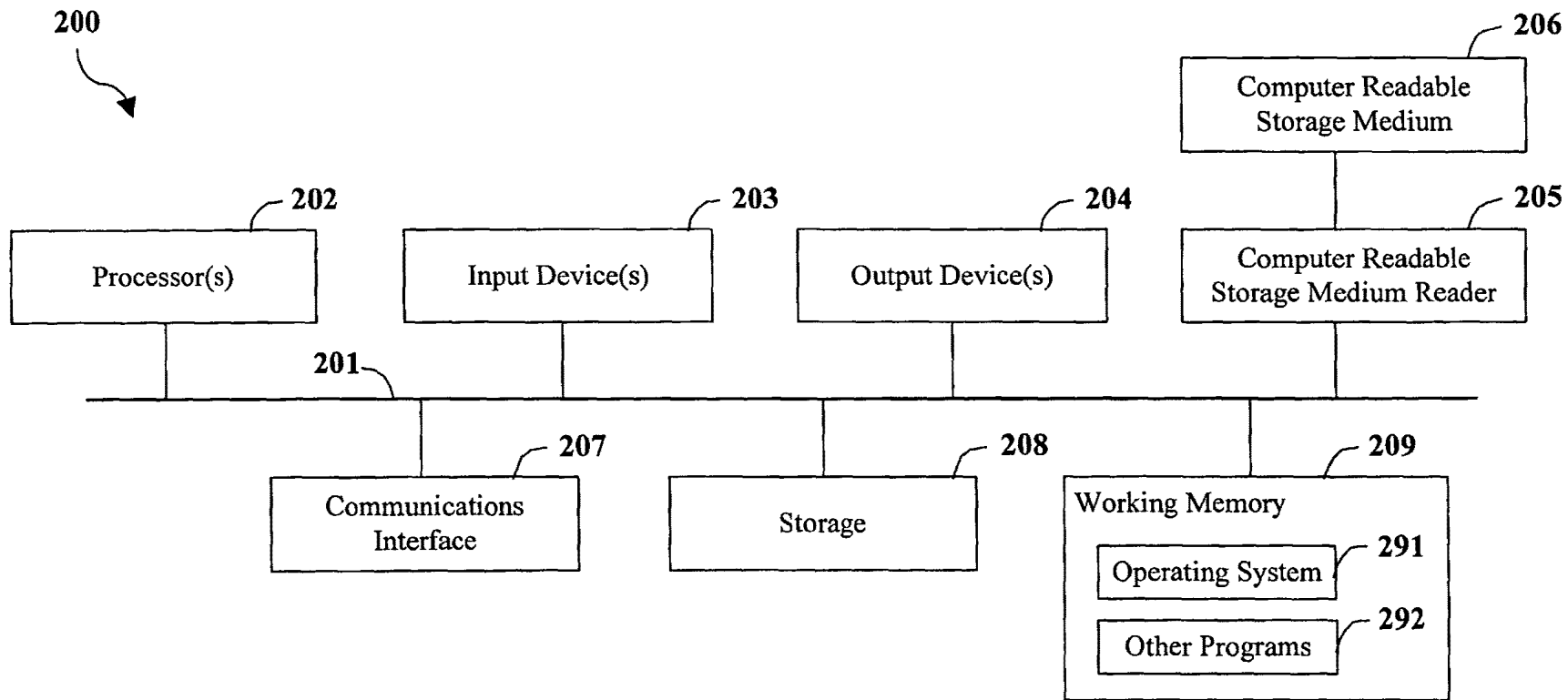

FIG. 2

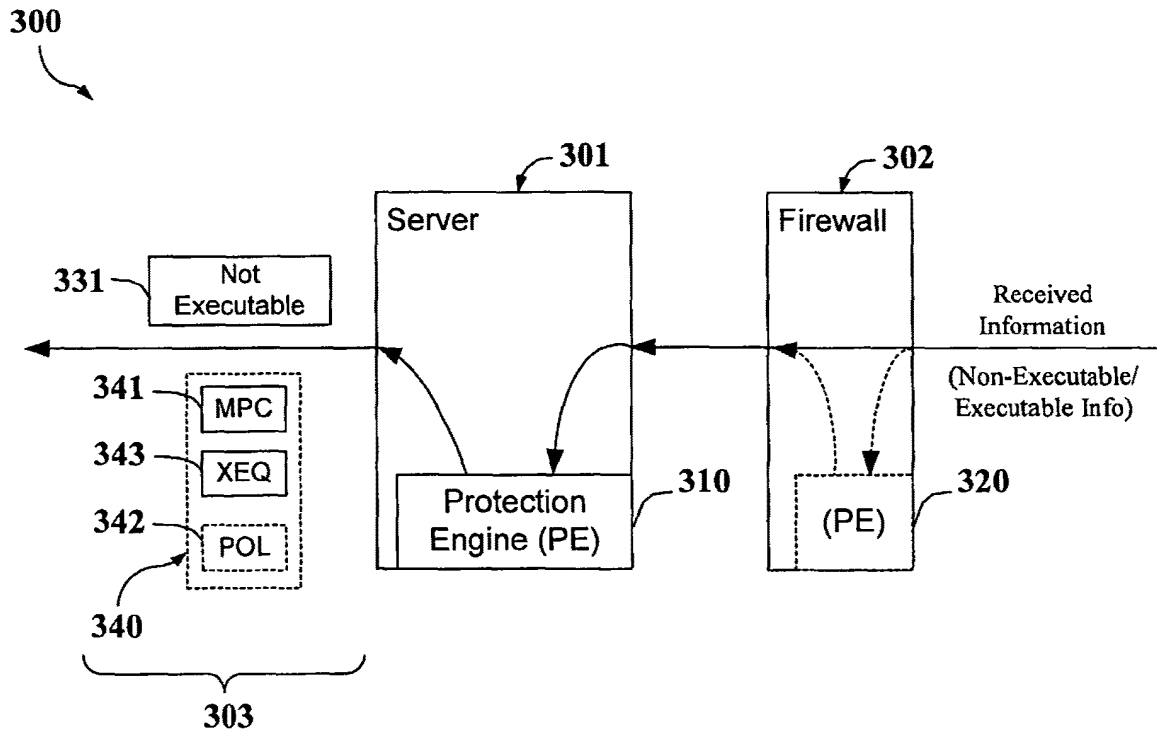

FIG. 3

400

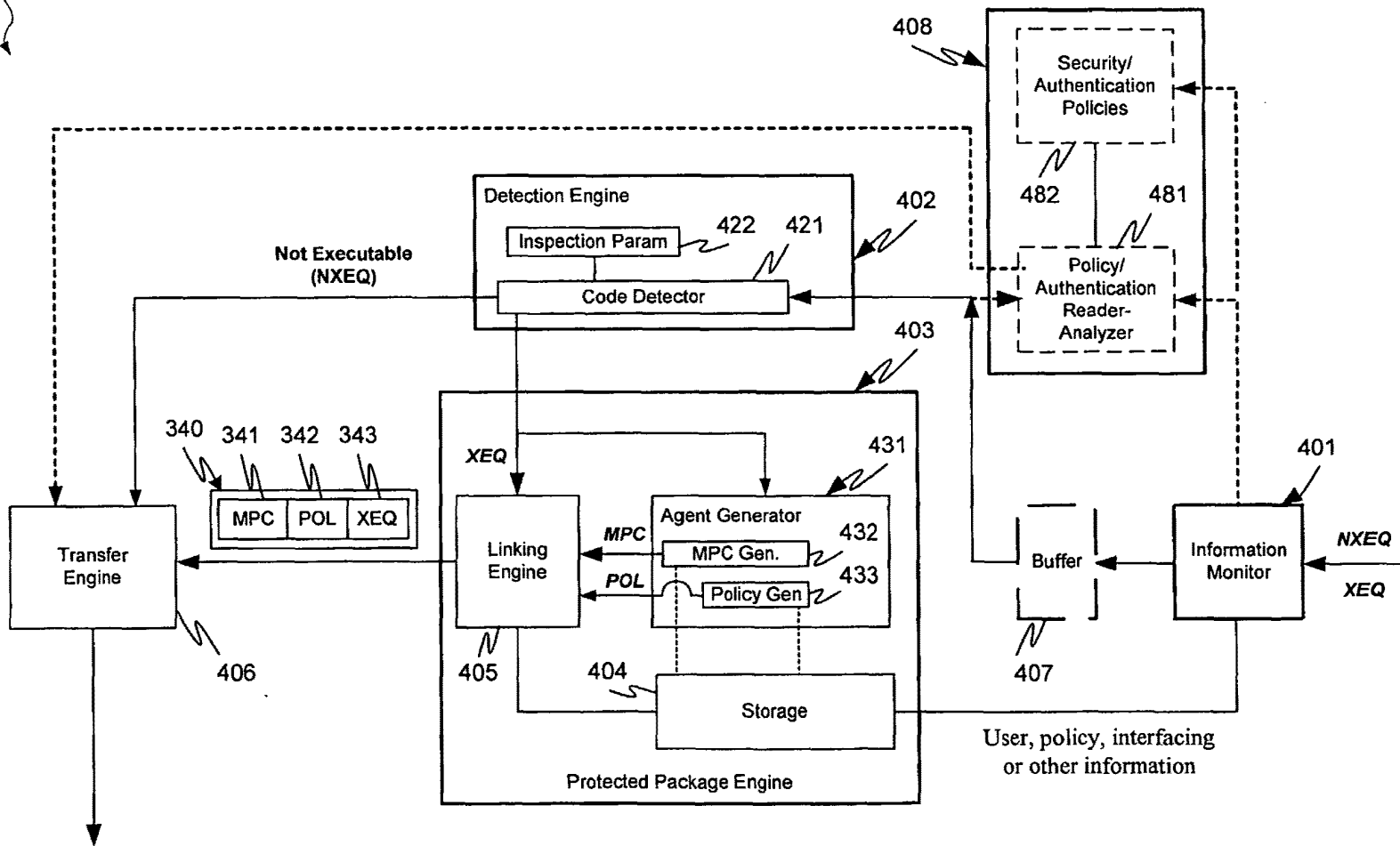

FIG. 4

FIG. 5a

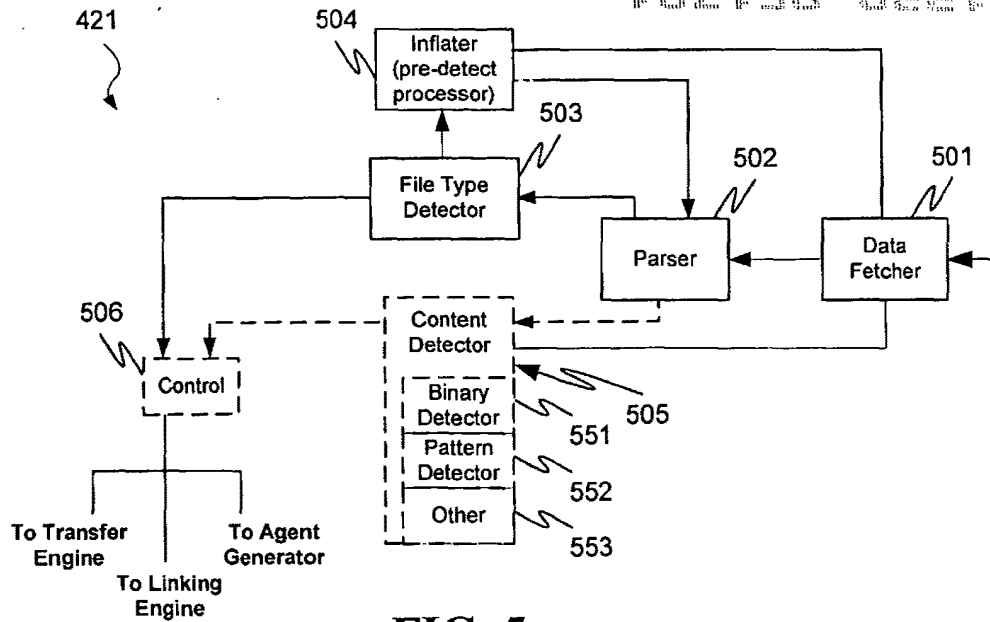

FIG. 5

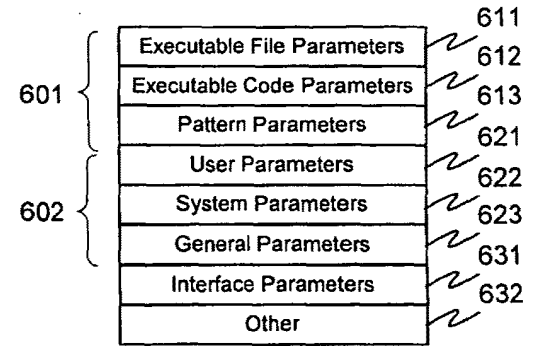

FIG. 6a

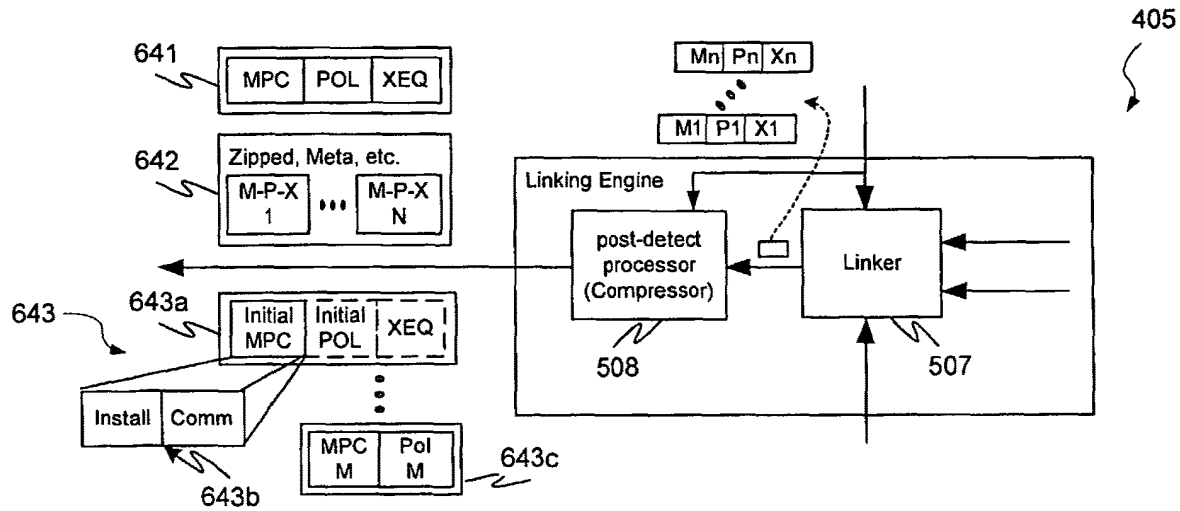

FIG. 6b

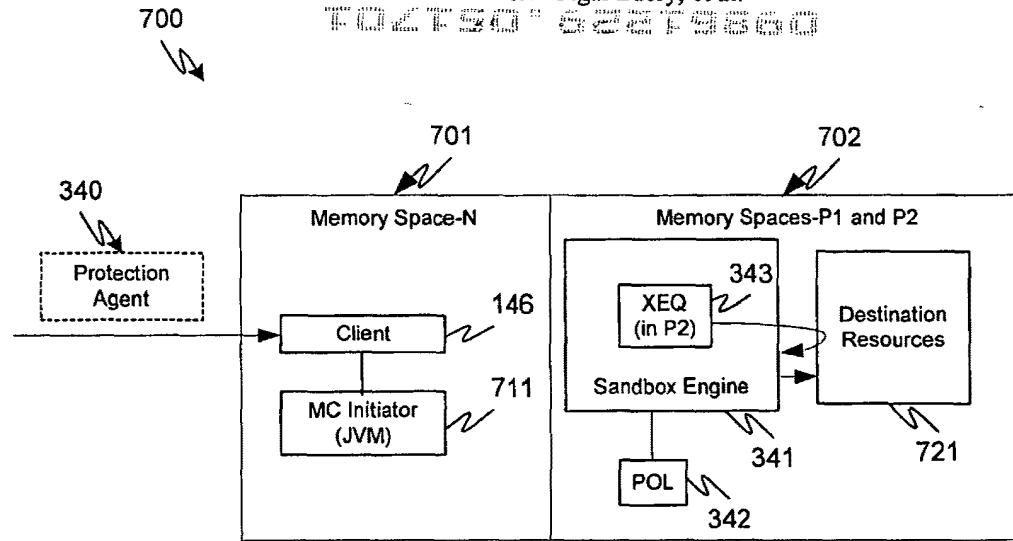

FIG. 7a

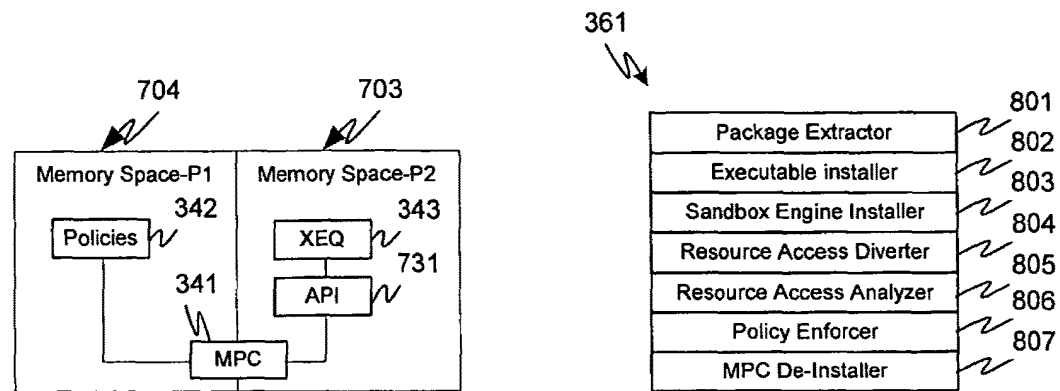

FIG. 7b

FIG. 8

FOIA b 7 - D

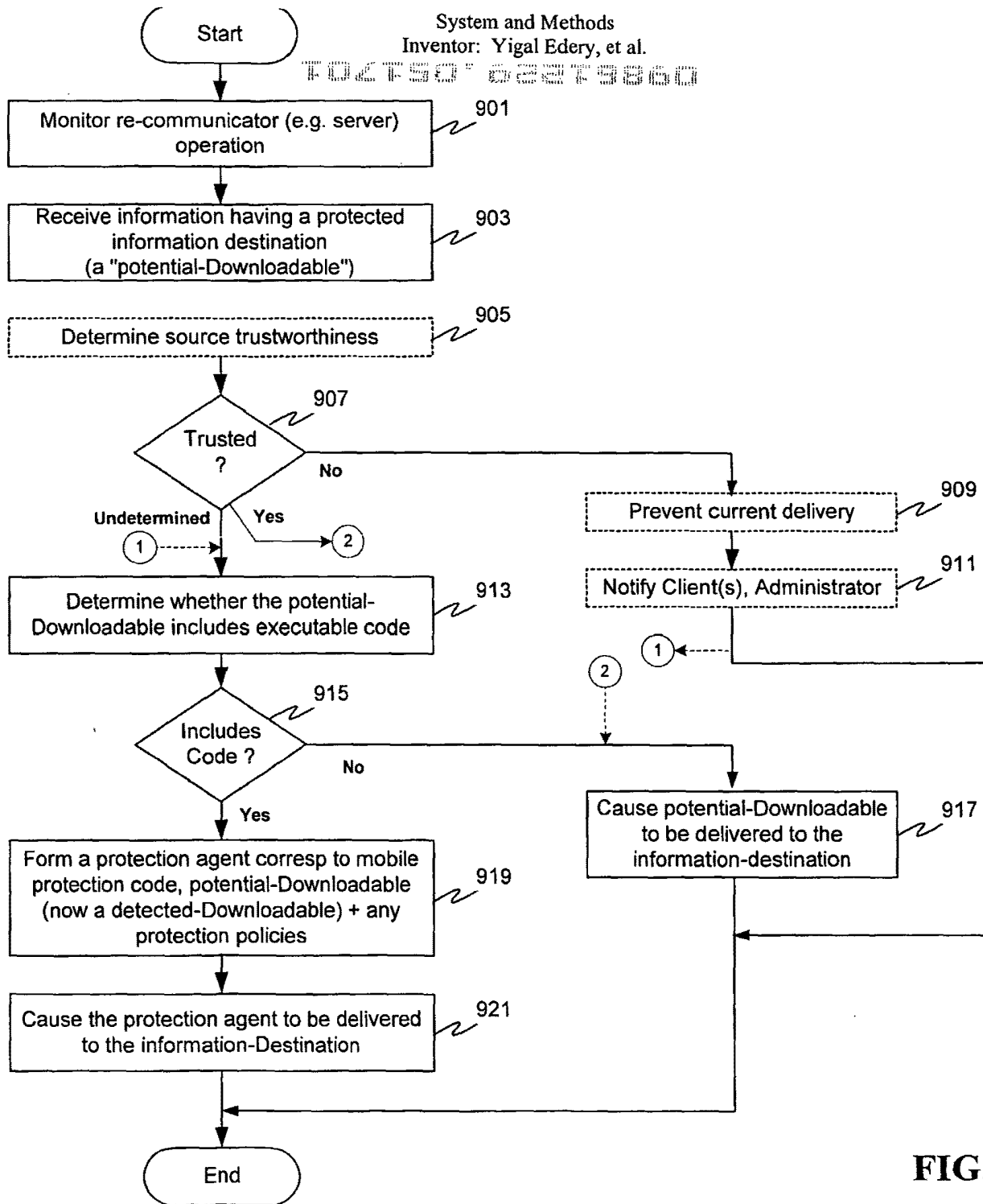

FIG. 9

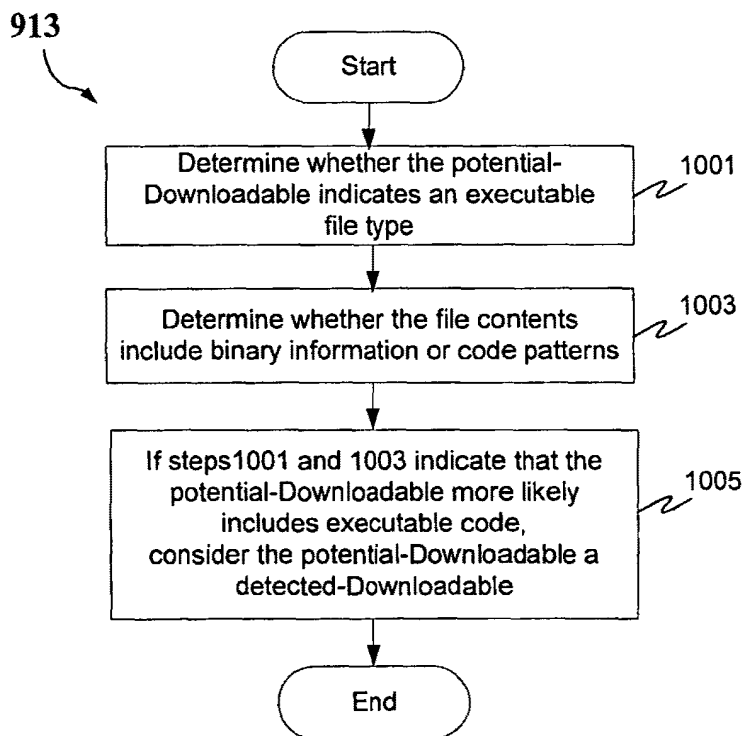

FIG. 10A

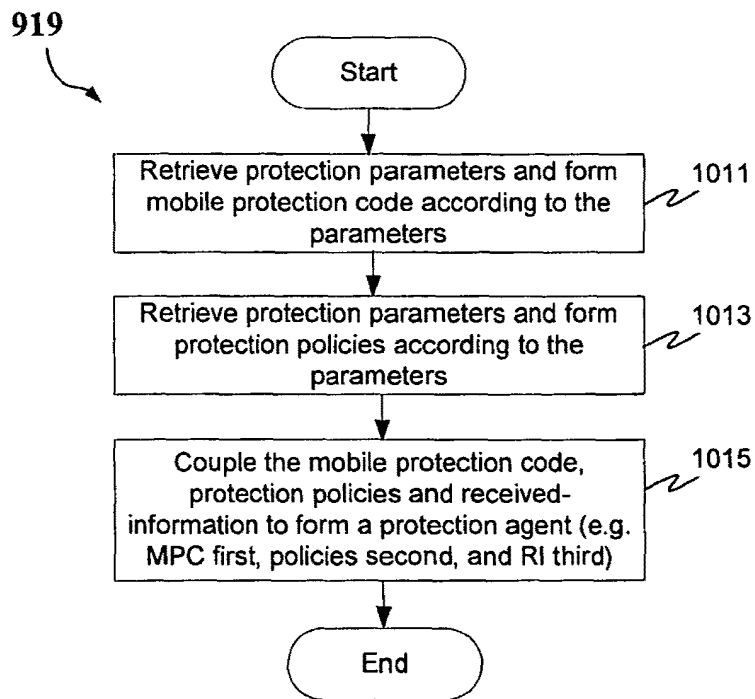

FIG. 10B

1069-00000000

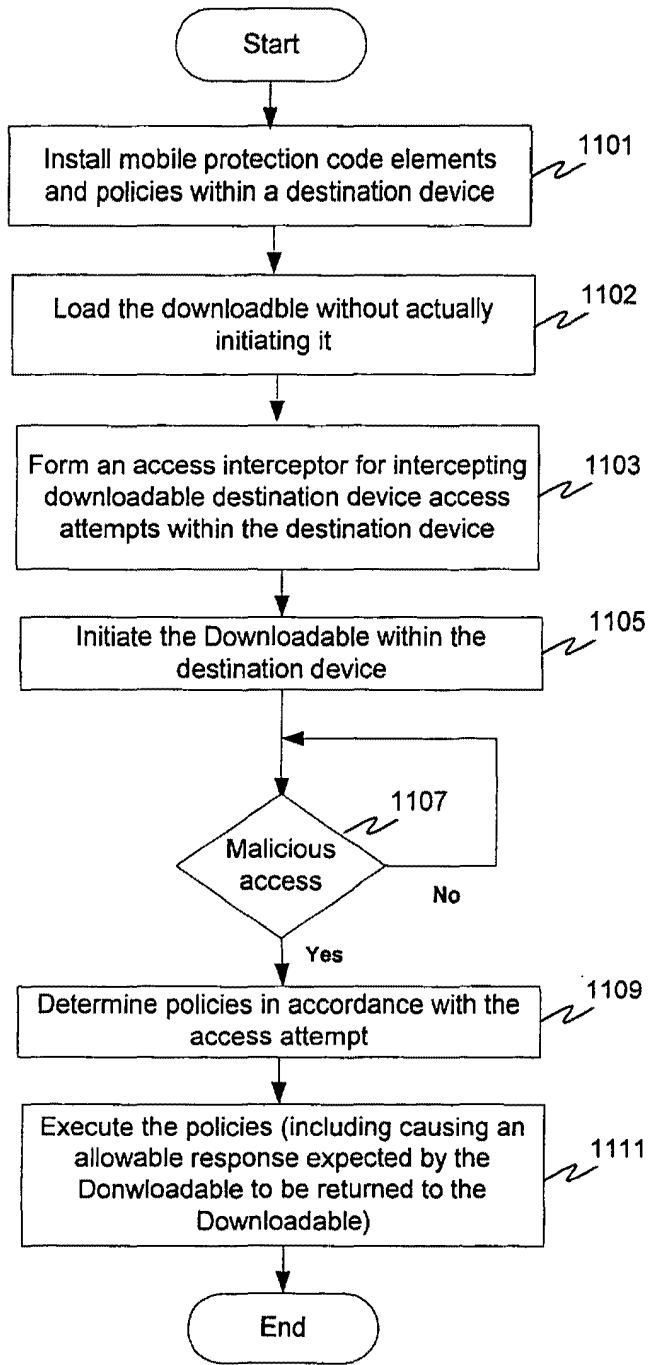

FIG. 11

1103

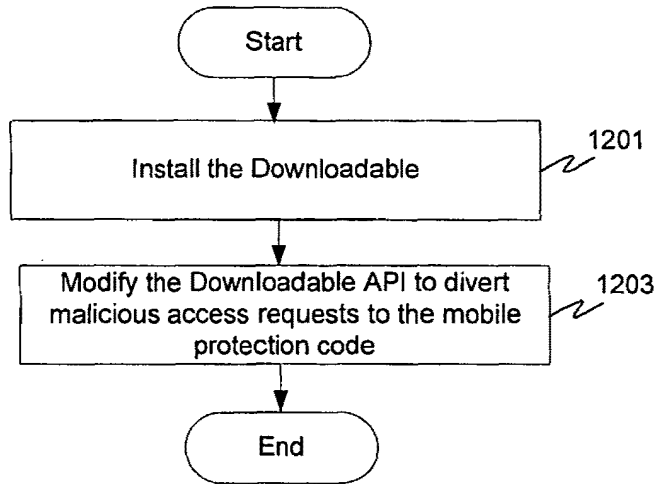

FIG. 12a

1109

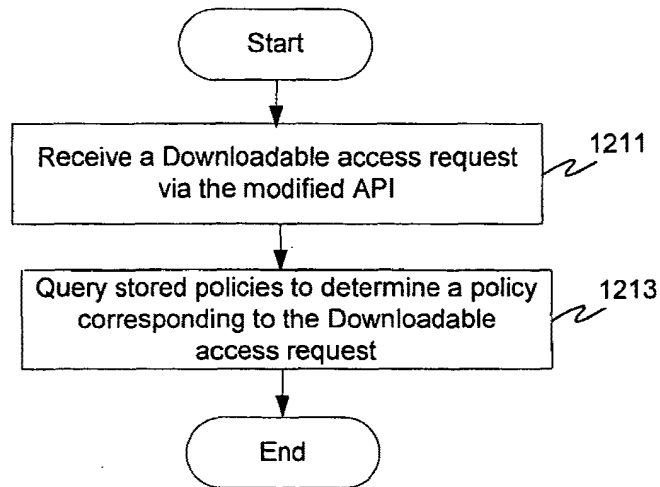

FIG. 12b



Under the Paperwork Reduction Act of 1995, no persons are required to respond to a collection of information unless it contains a valid OMB control number.

DECLARATION FOR UTILITY OR DESIGN PATENT APPLICATION (37 CFR 1.63) <input type="checkbox"/> Declaration Submitted With Initial Filing OR <input checked="" type="checkbox"/> Declaration Submitted after Initial Filing (surcharge (37 CFR 1.16 (e)) required)	Attorney Docket Number	43426.00014
	First Named Inventor	Yigal EDERY
	COMPLETE IF KNOWN	
	Application Number	09/861,229
	Filing Date	May 17, 2001
	Art Unit	2152
	Examiner Name	Unknown

I hereby declare that:

Each inventor's residence, mailing address, and citizenship are as stated below next to their name.

I believe the inventor(s) named below to be the original and first inventor(s) of the subject matter which is claimed and for which a patent is sought on the invention entitled:

MALICIOUS MOBILE CODE RUNTIME MONITORING SYSTEM AND METHODS

the specification of which (Title of the Invention)

is attached hereto
OR
 was filed on (MM/DD/YYYY) 5/17/2001 as United States Application Number or PCT International Application Number 09/861,229 and was amended on (MM/DD/YYYY) (if applicable).

I hereby state that I have reviewed and understand the contents of the above identified specification, including the claims, as amended specifically referred to above.

I acknowledge the duty to disclose information which is material to patentability as defined in 37 CFR 1.56, including for continuation-in-part applications, material information which became available between the filing date of the prior application and the national or PCT international filing date of the continuation-in-part application.

I hereby claim foreign priority benefits under 35 U.S.C. 119(a)-(d) or (f), or 385(b) of any foreign application(s) for patent, inventor's or plant breeder's rights certificate(s), or 385(a) of any PCT international application which designated at least one country other than the United States of America, listed below and have also identified below, by checking the box, any foreign application for patent, inventor's or plant breeder's rights certificate(s), or any PCT international application having a filing date before that of the application on which priority is claimed.

Prior Foreign Application Number(s)	Country	Foreign Filing Date (MM/DD/YYYY)	Priority Not Claimed	Certified Copy Attached?	
				YES	NO
			<input type="checkbox"/>	<input type="checkbox"/>	<input type="checkbox"/>
			<input type="checkbox"/>	<input type="checkbox"/>	<input type="checkbox"/>
			<input type="checkbox"/>	<input type="checkbox"/>	<input type="checkbox"/>
			<input type="checkbox"/>	<input type="checkbox"/>	<input type="checkbox"/>

Additional foreign application numbers are listed on a supplemental priority data sheet PTO/SB/02B attached hereto.

[Page 1 of 3]

This collection of information is required by 35 U.S.C. 115 and 37 CFR 1.63. The information is required to obtain or retain a benefit by the public which is to file (and by the USPTO to process) an application. Confidentiality is governed by 35 U.S.C. 122 and 37 CFR 1.14. This collection is estimated to take 21 minutes to complete, including gathering, preparing, and submitting the completed application form to the USPTO. Time will vary depending upon the individual case. Any comments on the amount of time you require to complete this form and/or suggestions for reducing this burden, should be sent to the Chief Information Officer, U.S. Patent and Trademark Office, U.S. Department of Commerce, P.O. Box 1450, Alexandria, VA 22313-1450. DO NOT SEND FEES OR COMPLETED FORMS TO THIS ADDRESS. SEND TO: Commissioner for Patents, P.O. Box 1450, Alexandria, VA 22313-1450.



If you need assistance in completing the form, call 1-800-PTO-9199 and select option 2.

PTO/SB/01 (08-03)

Approved for use through 07/31/2006. OMB 0851-0032
U.S. Patent and Trademark Office; U.S. DEPARTMENT OF COMMERCE

Under the Paperwork Reduction Act of 1995, no persons are required to respond to a collection of information unless it contains a valid OMB control number.

DECLARATION — Utility or Design Patent Application

Direct all correspondence to: <input checked="" type="checkbox"/> Customer Number <input type="checkbox"/> Correspondence address below			
30238			
Name			
Address			
City	State	ZIP	
Country	Telephone	Fax	
I hereby declare that all statements made herein of my own knowledge are true and that all statements made on information and belief are believed to be true; and further that these statements were made with the knowledge that willful false statements and the like so made are punishable by fine or imprisonment, or both, under 18 U.S.C. 1001 and that such willful false statements may jeopardize the validity of the application or any patent issued thereon.			
NAME OF SOLE OR FIRST INVENTOR:		<input type="checkbox"/> A petition has been filed for this unsigned inventor	
Given Name (first and middle (if any))	Yigal Mordechai	Family Name or Surname	EDERY
Inventor's Signature			Date 17/4/2005
Residence: City	State	Country	Citizenship
Pardesia	N/A	Israel	Israel
Mailing Address Hashikma 11, POB 1115			
City	State	Zip	Country
Pardesia	N/A	42815	Israel
NAME OF SECOND INVENTOR:		<input type="checkbox"/> A petition has been filed for this unsigned inventor	
Given Name (first and middle (if any))	Nimrod Itzhak	Family Name or Surname	VERED
Inventor's Signature			Date
Residence: City	State	Country	Citizenship
Goosh Tel-Mond	N/A	Israel	Israel
Mailing Address Moshav Mismaret #81			
City	State	Zip	Country
Goosh Tel-Mond	N/A	40695	Israel
<input checked="" type="checkbox"/> Additional inventors or a legal representative are being named on the 1 supplemental sheet(s) PTO/SB/02A or 02LR attached hereto.			

TOTAL P. 11

PTO/SB01 (08-03)

Approved for use through 07/01/2008, OMB 0831-0032

U.S. Patent and Trademark Office, U.S. DEPARTMENT OF COMMERCE

Under the Paperwork Reduction Act of 1996, no persons are required to respond to a collection of information unless it contains a valid OMB control number.

DECLARATION — Utility or Design Patent Application

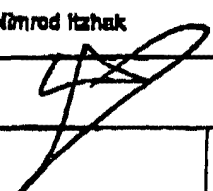
Direct all correspondence to:		<input checked="" type="checkbox"/> Customer Number	30258	OR	<input type="checkbox"/> Correspondence address below
Name					
Address					
City		State		ZIP	
Country			Telephone		Fax
I hereby declare that all statements made herein of my own knowledge are true and that all statements made on information and belief are believed to be true; and further that these statements were made with the knowledge that willful false statements and the like so made are punishable by fine or imprisonment, or both, under 18 U.S.C. 1001 and that such willful false statements may jeopardize the validity of the application or any patent issued thereon.					
NAME OF SOLE OR FIRST INVENTOR:				<input type="checkbox"/> A petition has been filed for this unsigned inventor	
Given Name (first and middle (if any))			Family Name or Surname		
Yigal Mordechai			EDERY		
Inventor's Signature				Date	
Residence: City		State	Country	Citizenship	
Pardeela		N/A	Israel	Israel	
Mailing Address					
Hashikma 11, POB 1115					
City		State	Zip	Country	
Pardeela		N/A	42815	Israel	
NAME OF SECOND INVENTOR:				<input type="checkbox"/> A petition has been filed for this unsigned inventor	
Given Name (first and middle (if any))			Family Name or Surname		
Nimrod Itzhak			VERED		
Inventor's Signature				Date	
				18/5/05	
Residence: City		State	Country	Citizenship	
Goosh Tel-Mond		N/A	Israel	Israel	
Mailing Address					
Moshav Miameret #81					
City		State	Zip	Country	
Goosh Tel-Mond		N/A	40885	Israel	
<input checked="" type="checkbox"/> Additional inventors or a legal representative are being named on the 1 supplemental sheet(s) PTO/SB/02A or 02LR attached hereto.					

TOTAL P.02

PTO/SB/02A (03-04)

Approved for use through 07/31/2005. OMB 0601-0002 U.S. Patent and Trademark Office, U.S. DEPARTMENT OF COMMERCE

Under the Password Protection Act of 1999, no person has required to respond to a collection of information unless it displays a valid OMB control number.

DECLARATION	ADDITIONAL INVENTOR(S) Supplemental Sheet
Page 2 of 2	

Name of Additional Inventor, if any		<input type="checkbox"/> A petition has been filed for this unsigned inventor	
Given Name (first and middle if any)		Family Name or Surname	
David S. KROTT			
Inventor's Signature <i>[Signature]</i>		Date <i>May 8, 2005</i>	
Residence: City San Jose	State CA	Country USA	Citizenship USA
Mailing Address 4650 Kingbreak Drive			
Mailing Address			
City San Jose	State CA	Zip 95134	Country USA
Name of Additional Inventor, if any		<input type="checkbox"/> A petition has been filed for this unsigned inventor	
Given Name (first and middle if any)		Family Name or Surname	
Shimon TONIEGUL			
Inventor's Signature <i>[Signature]</i>		Date <i>MARCH 6, 2005</i>	
Residence: City Kfar-Haim	State N/A	Country Israel	Citizenship Israel
Mailing Address			
Mailing Address			
City Kfar-Haim	State N/A	Zip 43945	Country Israel
Name of Additional Inventor, if any		<input type="checkbox"/> A petition has been filed for this unsigned inventor	
Given Name (first and middle if any)		Family Name or Surname	
Inventor's Signature		Date	
Residence: City	State	Country	Citizenship
Mailing Address			
Mailing Address			
City	State	Zip	Country

This collection of information is required by 35 U.S.C. 116 and 37 CFR 1.60. The information is required to obtain or retain a benefit by the public which is to be (and by the USPTO to process) an application. Consideration is governed by 35 U.S.C. 122 and 37 CFR 1.14. This collection is estimated to take 21 minutes to complete, including gathering, preparing, and submitting the completed application form to the USPTO. Time will vary depending upon the individual case. Any comments on the amount of time you require to complete this form and/or suggestions for reducing this burden, should be sent to the Chief Information Officer, U.S. Patent and Trademark Office, U.S. Department of Commerce, P.O. Box 1460, Alexandria, VA 22312-1460. DO NOT SEND FEES OR COMPLETED FORMS TO THIS ADDRESS. SEND TO: Commissioner for Patents, P.O. Box 1460, Alexandria, VA 22312-1460.

If you need assistance in completing the form, call 1-800-PTO-9199 (1-800-786-9199) and select option 2.

0014087492035 P.02

TO

03-MAY-2005 11:33 FROM FINJRN SOFTWARE

Best Available Copy

Under the Paperwork Reduction Act of 1995, no persons are required to respond to a collection of information unless it contains a valid OMB control number.

DECLARATION**ADDITIONAL INVENTOR(S)
Supplemental Sheet**

Page 3 of 3

Name of Additional Inventor, if any				<input type="checkbox"/> A petition has been filed for this unsigned inventor			
Given Name (first and middle (if any))				Family Name or Surname			
David R.				KROLL			
Inventor's Signature <i>X</i>				Date <i>X</i>			
Residence: City		San Jose		State		CA	
Country		USA		Citizenship		USA	
Mailing Address 4856 Kingbrook Drive							
Mailing Address							
City		San Jose		State		CA	
ZIP		95124		Country		USA	
Name of Additional Inventor, if any				<input type="checkbox"/> A petition has been filed for this unsigned inventor			
Given Name (first and middle (if any))				Family Name or Surname			
Shlomo				TOUBOUL			
Inventor's Signature <i>[Signature]</i>				Date <i>MARCH 6, 2005</i>			
Residence: City		Kefar-Haim		State		N/A	
Country		Israel		Citizenship		Israel	
Mailing Address							
Mailing Address							
City		Kefar-Haim		State		N/A	
Zip		42945		Country		Israel	
Name of Additional Inventor, if any				<input type="checkbox"/> A petition has been filed for this unsigned inventor			
Given Name (first and middle (if any))				Family Name or Surname			
Inventor's Signature				Date			
Residence: City		State		Country		Citizenship	
Mailing Address							
Mailing Address							
City		State		Zip		Country	

This collection of information is required by 35 U.S.C. 115 and 37 CFR 1.63. The information is required to obtain or retain a benefit by the public which is to file (and by the USPTO to process) an application. Confidentiality is governed by 35 U.S.C. 122 and 37 CFR 1.14. This collection is estimated to take 21 minutes to complete, including gathering, preparing, and submitting the completed application form to the USPTO. Time will vary depending upon the individual case. Any comments on the amount of time you require to complete this form and/or suggestions for reducing this burden, should be sent to the Chief Information Officer, U.S. Patent and Trademark Office, U.S. Department of Commerce, P.O. Box 1450, Alexandria, VA 22313-1450. DO NOT SEND FEES OR COMPLETED FORMS TO THIS ADDRESS. SEND TO: Commissioner for Patents, P.O. Box 1450, Alexandria, VA 22313-1450.

If you need assistance in completing the form, call 1-800-PTO-9199 (1-800-786-9199) and select option 2.

**MULTIPLE DEPENDENT CLAIM
FEE CALCULATION SHEET**

SERIAL NO.

FILING DATE

APPLICANT(S)

CLAIMS

	AS FILED		AFTER 1ST AMENDMENT		AFTER 3RD AMENDMENT	
	IND	DEP	IND	DEP	IND	DEP
1						
2						
3						
4						
5						
6						
7						
8						
9						
10						
11						
12						
13						
14						
15						
16						
17						
18						
19						
20						
21						
22						
23						
24						
25						
26						
27						
28						
29						
30						
31						
32						
33						
34						
35						
36						
37						
38						
39						
40						
41						
42						
43						
44						
45						
46						
47						
48						
49						
50						
TOTAL IND.						
TOTAL DEP.						
TOTAL CLAIMS						

	IND	DEP	IND	DEP	IND	DEP
51						
52						
53						
54						
55						
56						
57						
58						
59						
60						
61						
62						
63						
64						
65						
66						
67						
68						
69						
70						
71						
72						
73						
74						
75						
76						
77						
78						
79						
80						
81						
82						
83						
84						
85						
86						
87						
88						
89						
90						
91						
92						
93						
94						
95						
96						
97						
98						
99						
100						
TOTAL IND.						
TOTAL DEP.						
TOTAL CLAIMS						

MULTIPLE DEPENDENT CLAIM
FEE CALCULATION SHEET

SERIAL NO. 11370114

FILING DATE 03-07-06

APPLICANT(S)

CLAIMS

	AS FILED		AFTER 1ST AMENDMENT		AFTER 2ND AMENDMENT							
	IND	DEP	IND	DEP	IND	DEP						
10							51					
2							52					
3							53					
4							54					
5							55					
6							56					
7							57					
8							58					
9							59					
10							60					
11							61					
12							62					
13							63					
14							64					
15							65					
16							66					
17							67					
18							68					
19							69					
20							70					
21							71					
22							72					
23							73					
24							74					
25							75					
26							76					
27							77					
28							78					
29							79					
30							80					
31							81					
32							82					
33							83					
34							84					
35							85					
36							86					
37							87					
38							88					
39							89					
40							90					
41							91					
42							92					
43							93					
44							94					
45							95					
46							96					
47							97					
48							98					
49							99					
50							100					
TOTAL IND.	←		←		←		TOTAL IND.	21	←		←	
TOTAL DEP.	←		←		←		TOTAL DEP.	54	←		←	
TOTAL CLAIMS	←		←		←		TOTAL CLAIMS	75	←		←	

151
76
75

PATENT APPLICATION SERIAL NO. _____

U.S. DEPARTMENT OF COMMERCE
PATENT AND TRADEMARK OFFICE
FEE RECORD SHEET

03/10/2006 WASFAW1 00000060 503400 11370114

01 FC:1011	300.00 DA
02 FC:1111	500.00 DA
03 FC:1311	200.00 DA
04 FC:1201	3600.00 DA
05 FC:1202	2750.00 DA

PTO-1556

(5/87)

Under the Paperwork Reduction Act of 1995, no persons are required to respond to a collection of information unless it displays a valid OMB control number.

PATENT APPLICATION FEE DETERMINATION RECORD

Substitute for Form PTO-875 Effective December 8, 2004

Application or Docket Number
 11370114

APPLICATION AS FILED - PART I

FOR	NUMBER FILED (Column 1)	NUMBER EXTRA (Column 2)
BASIC FEE (37 CFR 1.16(a), (b), or (c))	N/A	N/A
SEARCH FEE (37 CFR 1.16(d), (e), or (m))	N/A	N/A
EXAMINATION FEE (37 CFR 1.16(g), (h), or (u))	N/A	N/A
TOTAL CLAIMS (37 CFR 1.16(i))	75 minus 20 =	55
INDEPENDENT CLAIMS (37 CFR 1.16(h))	21 minus 3 =	18
APPLICATION SIZE FEE (37 CFR 1.16(s))	If the specification and drawings exceed 100 sheets of paper, the application size fee due is \$250 (\$125 for small entity) for each additional 50 sheets or fraction thereof. See 35 U.S.C. 41(a)(1)(G) and 37 CFR 1.16(s).	
MULTIPLE DEPENDENT CLAIM PRESENT (37 CFR 1.16(j))		

SMALL ENTITY

RATE (\$)	FEE (\$)
N/A	150.00
N/A	\$250
N/A	\$100
X\$ 25 =	
X100 =	
+180=	
TOTAL	

OR OTHER THAN SMALL ENTITY

RATE (\$)	FEE (\$)
N/A	300.00
N/A	\$500
N/A	\$200
X\$50 =	2750
X200 =	3600
+360=	
TOTAL	7350

* If the difference in column 1 is less than zero, enter "0" in column 2.

APPLICATION AS AMENDED - PART II

AMENDMENT A

	CLAIMS REMAINING AFTER AMENDMENT (Column 1)	HIGHEST NUMBER PREVIOUSLY PAID FOR (Column 2)	PRESENT EXTRA (Column 3)
Total (37 CFR 1.16(i))	Minus	**	=
Independent (37 CFR 1.16(h))	Minus	***	=
Application Size Fee (37 CFR 1.16(s))			
FIRST PRESENTATION OF MULTIPLE DEPENDENT CLAIM (37 CFR 1.16(j))			

SMALL ENTITY

RATE (\$)	ADDITIONAL FEE (\$)
X\$ 25 =	
X100 =	
+180=	
TOTAL ADD'L FEE	

OR OTHER THAN SMALL ENTITY

RATE (\$)	ADDITIONAL FEE (\$)
X\$50 =	
X200 =	
+360=	
TOTAL ADD'L FEE	

AMENDMENT B

	CLAIMS REMAINING AFTER AMENDMENT (Column 1)	HIGHEST NUMBER PREVIOUSLY PAID FOR (Column 2)	PRESENT EXTRA (Column 3)
Total (37 CFR 1.16(i))	Minus	**	=
Independent (37 CFR 1.16(h))	Minus	***	=
Application Size Fee (37 CFR 1.16(s))			
FIRST PRESENTATION OF MULTIPLE DEPENDENT CLAIM (37 CFR 1.16(j))			

SMALL ENTITY

RATE (\$)	ADDITIONAL FEE (\$)
X\$ 25 =	
X100 =	
+180=	
TOTAL ADD'L FEE	

OR OTHER THAN SMALL ENTITY

RATE (\$)	ADDITIONAL FEE (\$)
X\$50 =	
X200 =	
+360=	
TOTAL ADD'L FEE	

* If the entry in column 1 is less than the entry in column 2, write "0" in column 3.
 ** If the "Highest Number Previously Paid For" IN THIS SPACE is less than 20, enter "20".
 *** If the "Highest Number Previously Paid For" IN THIS SPACE is less than 3, enter "3".

The "Highest Number Previously Paid For" (Total or independent) is the highest number found in the appropriate box in column 1.

This collection of information is required by 37 CFR 1.16. The information is required to obtain or retain a benefit by the public which is to file (and by the USPTO to process) an application. Confidentiality is governed by 35 U.S.C. 122 and 37 CFR 1.14. This collection is estimated to take 12 minutes to complete, including gathering, preparing, and submitting the completed application form to the USPTO. Time will vary depending upon the individual case. Any comments on the amount of time you require to complete this form and/or suggestions for reducing this burden, should be sent to the Chief Information Officer, U.S. Patent and Trademark Office, U.S. Department of Commerce, P.O. Box 1450, Alexandria, VA 22313-1450. DO NOT SEND FEES OR COMPLETED FORMS TO THIS ADDRESS. SEND TO: Commissioner for Patents, P.O. Box 1450, Alexandria, VA 22313-1450.

PATENT
ELG-P-9139US2

IN THE UNITED STATES PATENT AND TRADEMARK OFFICE

Applicants : Yigal Mordechai Edery et al.
U.S. Serial No. : unknown
Filed : herewith
Title : MALICIOUS MOBILE CODE RUNTIME MONITORING
SYSTEM AND METHODS
Group Art Unit : unknown
Examiner : unknown

EXPRESS MAIL MAILING LABEL NUMBER EO 399946563 US, Date of Deposit: March 7, 2006

I hereby certify that this paper or fee is being deposited with the United States Postal Service "Express Mail Post Office to Addressee" Service under 37 CFR 1.10 on the date indicated above and is addressed to the Commissioner for Patents, P.O. Box 1450, Alexandria, VA 22313-1450.

Andrew L. Tiajloff
(Name of person mailing paper or fee)

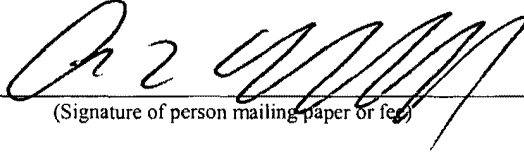

March 7, 2006
Date

Commissioner for Patents
P.O. Box 1450
Alexandria, VA 22313-1450

PRELIMINARY AMENDMENT

Sir:

Please amend the accompanying application as follows:

IN THE TITLE:

Please amend the Title as follows:

-- METHOD AND MALICIOUS MOBILE CODE RUNTIME MONITORING
SYSTEM FOR PROTECTING A COMPUTER AND METHODS A NETWORK
FROM HOSTILE DOWNLOADABLES

IN THE SPECIFICATION

On page 1, please amend the paragraph starting at line 5 as follows:

-- This application is a continuation of assignee's pending application serial no. 09/861,229, filed on May 17, 2001, entitled "Malicious Mobile Code Runtime Monitoring System And Methods", which is hereby incorporated by reference. U.S. application serial no. 09/861,229 claims benefit of [~~and hereby incorporates by reference~~] provisional application serial number 60/205,591, entitled "Computer Network Malicious Code Run-time Monitoring," filed on May 17, 2000 by inventors Nimrod Itzhak Vered, et al., which is hereby incorporated by reference. U.S. application serial no. 09/861,229 [~~This application~~] is also a Continuation-In-Part of [~~and hereby incorporates by reference~~] U.S. patent application serial number 09/539,667, entitled "System and Method for Protecting a Computer and a Network From Hostile Downloadables" filed on March 30, 2000 by inventor Shlomo Touboul, now U.S. Patent 6,804,780, and hereby incorporated by reference, which is a continuation of assignee's patent application U.S. Serial No. 08/964,388, filed on November 6, 1997, now U.S. Patent No. 6,092,194, also entitled "System and Method for Protecting a Computer and a Network from Hostile Downloadables" and hereby incorporated by reference. U.S. Serial No. 09/861,229 [~~This application~~] is also a Continuation-In-Part of [~~and hereby incorporates by reference~~] U.S. patent application serial number 09/551,302, entitled "System and Method for Protecting a Client During Runtime From Hostile Downloadables", filed on April 18, 2000 by inventor Shlomo Touboul, now U.S. Patent No. 6,480,962, which is hereby incorporated by reference.

IN THE CLAIMS:

Please cancel the claims 1 to 76 without prejudice and add the following new claims:
1 to 76 (canceled).

77. (new) A computer-based method, comprising the steps of:
receiving an incoming Downloadable;
deriving security profile data for the Downloadable, including a list of
suspicious computer operations that may be attempted by the Downloadable;
and
storing the Downloadable security profile data in a database.
78. (new) The computer-based method of claim 77 further comprising storing a date &
time when the Downloadable security profile data was derived in the database.
79. (new) The computer-based method of claim 77 wherein the Downloadable includes
a Java applet.
80. (new) The computer-based method of claim 77 wherein the Downloadable includes
an ActiveX control.
81. (new) The computer-based method of claim 77 wherein the Downloadable includes
a JavaScript script.
82. (new) The computer-based method of claim 77 wherein the Downloadable includes
a Visual Basic script.
83. (new) The computer-based method of claim 77 wherein suspicious computer
operations include calls made to an operating system, a file system, a network system, a
network system, and to memory.

84. (new) The computer-based method of claim 77 wherein the Downloadable security profile data includes a URL from where the Downloadable originated.
85. (new) The computer-based method of claim 77 wherein the Downloadable security profile data includes a digital certificate.
86. (new) The computer-based method of claim 77 wherein said deriving Downloadable security profile data comprises disassembling the incoming Downloadable.
87. (new) A system for managing Downloadables, comprising:
a receiver for receiving an incoming Downloadable;
a Downloadable scanner coupled with said receiver, for deriving security profile data for the Downloadable, including a list of suspicious computer operations that may be attempted by the Downloadable; and
a database manager coupled with said Downloadable scanner, for storing the Downloadable security profile data in a database.
88. (new) The system of claim 87 wherein said database manager also stores a date & time when the Downloadable security profile data was derived by said Downloadable scanner, in the database.
89. (new) The system of claim 87 wherein the Downloadable includes a Java applet.
90. (new) The system of claim 87 wherein the Downloadable includes an ActiveX control.
91. (new) The system of claim 87 wherein the Downloadable includes a JavaScript script.
92. (new) The system of claim 87 wherein the Downloadable includes a Java applet.

93. (new) The system of claim 87 wherein suspicious computer operations include calls made to an operating system, a file system, a network system, and to memory.

94. (new) The system of claim 87 wherein the Downloadable security profile data includes a URL from where the Downloadable originated.

95. (new) The system of claim 87 wherein the Downloadable security profile data includes a digital certificate.

96. (new) The system of claim 87 wherein said Downloadable scanner comprises a disassembler for a disassembling the incoming Downloadable.

97. (new) A computer-based method, comprising the steps of:
receiving an incoming Downloadable;
deriving security profile data for the Downloadable, including a list of suspicious computer operations that may be attempted by the Downloadable;
appending a representation of the Downloadable security profile data to the Downloadable, to generate an appended Downloadable; and
transmitting the appended Downloadable to a destination computer.

98. (new) The computer-based method of claim 97 wherein the Downloadable includes a Java applet.

99. (new) The computer-based method of claim 97 wherein the Downloadable includes an ActiveX control.

100. (new) The computer-based method of claim 97 wherein the Downloadable includes a JavaScript script.

101. (new) The computer-based method of claim 97 wherein the Downloadable includes a Visual Basic script.

102. (new) The computer-based method of claim 97 wherein suspicious computer operations include calls made to an operating system, a file system, a network system, and to memory.

103. (new) The computer-based method of claim 97 wherein the Downloadable security profile data includes a URL from where the Downloadable originated.

104. (new) The computer-based method of claim 97 wherein the appended Downloadable includes a digital certificate.

105. (new) The computer-based method of claim 97 wherein said deriving Downloadable security profile data comprises disassembling the incoming Downloadable.

106. (new) A system for managing Downloadables, comprising:
a receiver for receiving an incoming Downloadable;
a Downloadable scanner coupled with said receiver for deriving security profile data for Downloadable, including a list of suspicious computer operations that may be attempted by the Downloadable;
a file appender coupled with said Downloadable scanner, for appending a representation of the Downloadable security profile data to the Downloadable, to generate an appended an appended Downloadable; and
a transmitter coupled with said file appender, for transmitting the appended Downloadable to a destination computer.

107. (new) The system of claim 106 wherein the Downloadable includes a Java applet.

108. (new) The system of claim 106 wherein the Downloadable includes a ActiveX control.

109. (new) The system of claim 106 wherein the Downloadable includes a JavaScript script.

110. (new) The system of claim 106 wherein the Downloadable includes a Visual Basic script.

111. (new) The system of claim 106 wherein suspicious computer operations include calls made to an operating system, a file system, a network system, and to memory.

112. (new) The system of claim 106 wherein the Downloadable security profile data includes a URL from where the Downloadable originated.

113. (new) The system of claim 106 wherein the appended Downloadable includes a digital certificate.

114. (new) The system of claim 106 wherein said Downloadable scanner comprises a disassembler for disassembling the incoming Downloadable.

115. (new) A computer-based method, comprising the steps of:
receiving an incoming Downloadable;
deriving security profile data for Downloadable, including a list of suspicious computer operations that may be attempted by the Downloadable; and
transmitting the Downloadable and a representation of the Downloadable security profile data to a destination computer, via a transport protocol transmission.

116. (new) The computer-based method of claim 115 wherein the transport protocol is an application transport protocol, and wherein the Downloadable security profile data is inserted as a header within the transport protocol transmission.

117. (new) The computer-based method of claim 116 wherein the application transport protocol is HTTP.

118. (new) The computer-based method of claim 116 wherein the application transport protocol is FTP.

119. (new) The computer-based method of claim 115 wherein the transport protocol is network transport protocol, and wherein the Downloadable security profile data is inserted as a frame within the transport protocol transmission.

120. (new) The computer-based method of claim 119 wherein the network transport protocol is TCP/IP.

121. (new) The computer-based method of claim 119 wherein the network transport protocol is UDP.

122. (new) A system for managing Downloadables, comprising:
a receiver for receiving an incoming Downloadable;
a Downloadable scanner coupled with said receiver, for deriving security profile data for the Downloadable, including a list of suspicious computer operations that may be attempted by the Downloadable; and
a transmitter coupled with said receiver and with said Downloadable scanner, for transmitting the Downloadable and a representation of the Downloadable security profile data to a destination computer, via a transport protocol transmission.

123. (new) The system of claim 122 wherein the transport protocol is an application transport protocol and wherein the Downloadable security profile data is inserted as a header within the transport protocol transmission.

124. (new) The system of claim 123, wherein the application transport protocol is HTTP.

125. (new) The system of claim 123, wherein the application transport protocol is FTP.

126. (new) The system of claim 122 wherein the transport protocol is a network transport protocol, and wherein the Downloadable security profile data is inserted as a frame within the transport protocol transmission.

127. (new) The system of claim 126 wherein the network transport protocol is TCP/IP.

128. (new) The system of claim 126 wherein the network transport protocol is UDP.

129. (new) A computer-based method, comprising the steps of:
receiving an incoming Downloadable;
receiving security profile data for the Downloadable, including a list of suspicious computer operations that may be attempted by the Downloadable;
appending a representation of the Downloadable security profile data to the Downloadable, to generate an appended Downloadable; and
transmitting the appended Downloadable to a destination computer.

130. (new) The computer-based method of claim 129 further comprising forwarding the Downloadable to an external computer, for deriving the Downloadable security profile data.

131. (new) A system for managing Downloadables, comprising:
a receiver for receiving an incoming Downloadable, and for receiving security profile data for the Downloadable, including a list of suspicious computer operations that may be attempted by the Downloadable;
a file appender coupled with said receiver for appending a representation of the Downloadable security profile data to the Downloadable, to generate an appended Downloadable; and
a transmitter coupled with said file appender, for transmitting the appended Downloadable to a destination computer.

132. (new) The system of claim 131 wherein said transmitter forwards the Downloadable to an external computer, for deriving the Downloadable security profile data, and wherein said receiver receives the security profile data from the external computer.

133. (new) A computer-based method, comprising the steps of:
receiving an incoming Downloadable;
receiving security profile data for the Downloadable, including a list of suspicious computer operations that may be attempted by the Downloadable; and
transmitting the Downloadable and a representation of the Downloadable security profile data to a destination computer, via a transport protocol transmission.

134. (new) The computer-based method of claim 133 further comprising forwarding the Downloadable to an external computer, for deriving the Downloadable security profile data.

135. (new) A system for managing Downloadables, comprising:
a receiver for receiving an incoming Downloadable, and for receiving security profile data for the Downloadable, including a list of suspicious computer operations that may be attempted by the Downloadable; and
a transmitter coupled with said receiver, for transmitting the Downloadable and a representation of the Downloadable security profile data to a destination computer, via a transport protocol transmission.

136. (new) The system of claim 135 wherein said transmitter forwards the Downloadable to an external computer, for deriving the Downloadable security profile data, and wherein said receiver receives the security profile data from the external computer.

137. (new) A computer-based method, comprising the steps of:
receiving an incoming Downloadable addressed;
retrieving security profile data for the incoming Downloadable from a database of Downloadable security profiles indexed according to Downloadable IDs, based on an ID of the incoming Downloadable, the security profile data including a list of suspicious computer

operations that may be attempted by the Downloadable;

appending a representation of the retrieved Downloadable security profile data to the incoming Downloadable, to generate an appended Downloadable; and

transmitting the appended Downloadable to a destination computer.

138. (new) The computer-based method of claim 137 further comprising performing a hashing function on the incoming Downloadable to compute the incoming Downloadable ID.

139. (new) A system for managing Downloadables, comprising:

a receiver for receiving an incoming Downloadable addressed to a client;

a database manager for retrieving security profile data for the incoming Downloadable from a database of Downloadable security profiles indexed according to Downloadable IDs, based on an ID of the incoming Downloadable, the security profiled data including a list of suspicious computer operations that may be attempted by the Downloadable;

a file appender coupled with said receiver for appending a representation of the Downloadable security profile data to the incoming Downloadable, to generate an appended Downloadable; and

a transmitter coupled with said file appender, for transmitting the appended Downloadable to a destination computer.

140. (new) The system of claim 139 further comprising a Downloadable identifier for performing a hashing function on the incoming Downloadable to compute the incoming Downloadable to compute the incoming Downloadable ID.

141. (new) A computer-based method, comprising the steps of:

receiving an incoming Downloadable;

receiving security profile data for the incoming Downloadable from a database of Downloadable security profiles indexed according to Downloadable IDs, based on an ID of the incoming Downloadable, the security profiled data including a list of suspicious computer operations that may be attempted by the Downloadable; and

transmitting the incoming Downloadable and a representation of the retrieved Downloadable security profiled data to a destination computer, via a transport protocol transmission.

142. (new) The computer-based method of claim 141 further comprising performing a hashing function on the incoming Downloadable to compute the incoming Downloadable ID.

143. (new) A system for managing Downloadable, comprising;
a receiver for receiving an incoming Downloadable addressed to a client;
a database manager for retrieving security profile data for the incoming Downloadable from a database of Downloadable security profiles indexed according to Downloadable IDs, based on an ID of the incoming Downloadable, the security profiled data including a list of suspicious computer operations that may be attempted by the Downloadable; and

a transmitter coupled with said receiver, for transmitting the incoming Downloadable and a representation of the retrieved Downloadable security profile data to a destination computer, via a transport protocol transmission.

144. (new) The system of claim 143 further comprising a Downloadable identifier for performing a hashing function on the incoming Downloadable to compute the incoming Downloadable to compute the incoming Downloadable ID.

145. (new) The system of claim 143 further comprising a Downloadable identifier for performing a hashing function on the incoming Downloadable to compute the incoming Downloadable ID.

receive an incoming Downloadable;
derive security profile data for the Downloadable, including a list of suspicious computer operations that may be attempted by the Downloadable; and
store the Downloadable security profile data in a database.

146. (new) A computer-readable storage medium storing program code for causing at least one computing device to:

receive an incoming Downloadable;

derive security profile data for the Downloadable, including a list of suspicious computer operations that may be attempted by the Downloadable;

append a representation of the Downloadable security profile data to the Downloadable, to generate an appended Downloadable; and

transmit the appended Downloadable to a destination computer.

147. (new) A computer-readable storage medium storing program code for causing at least one computing device to:

receive an incoming Downloadable;

derive security profile data for the Downloadable, including a list of suspicious computer operations that may be attempted by the Downloadable; and

transmit the Downloadable and a representation of the Downloadable security profile data to a destination computer, via a transport protocol transmission.

148. (new) A computer-readable storage medium storing program code for causing at least one computing device to:

receive an incoming Downloadable;

receive security profile data for the Downloadable, including a list of suspicious computer operations that may be attempted by the Downloadable;

append a representation of the Downloadable security profile data to the Downloadable, to generate an appended Downloadable; and

transmit the appended Downloadable to a destination computer.

149. (new) A computer-readable storage medium storing program code for causing at least one computing device to:

receive an incoming Downloadable;

receive security profile data for the Downloadable, including a list of suspicious computer operations that may be attempted by the Downloadable; and

transmit the Downloadable and a representation of the Downloadable security profile data to a destination computer, via a transport protocol transmission.

150. (new) A computer-readable storage medium storing program code for causing at least one computing device to:

- receive an incoming Downloadable;
- retrieve security profile data for the incoming Downloadable from a database of Downloadable security profiles indexed according to Downloadable IDs, based on an ID of the incoming Downloadable, the security profiled data including a list of suspicious computer operations that may be attempted by the Downloadable;
- append a representation of the retrieved Downloadable security profile data to the incoming Downloadable, to generate an appended Downloadable; and
- transmit the appended Downloadable to a destination computer.

151. (new) A computer-readable storage medium storing program code for causing at least one computing device to:

- receive an incoming Downloadable;
- retrieve security profile data for the incoming Downloadable from a database of Downloadable security profiles indexed according to Downloadable IDs, based on an ID of the incoming Downloadable, the security profiled data including a list of suspicious computer operations that may be attempted by the Downloadable; and
- transmit the incoming Downloadable and a representation of the retrieved Downloadable security profile data to a destination computer, via a transport protocol transmission.

REMARKS

This amendment inserts the assertion of US domestic priority for this application, amends the title, and adds new claims for the continuation.

Should any questions arise, the Patent Office is invited to telephone attorney for applicants at 212-490-3285.

Respectfully submitted,

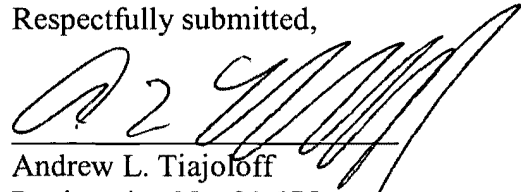

Andrew L. Tiajoff
Registration No. 31,575

Tiajoff & Kelly
Chrysler Building, 37th floor
405 Lexington Avenue
New York, NY 10174

tel. 212-490-3285
fax 212-490-3295

Application Data Sheet

Application Information

Application Type:: Regular
Subject Matter:: Utility
CD-ROM or CD-R? None
Title:: METHOD AND SYSTEM FOR PROTECTING A
COMPUTER AND A NETWORK FROM HOSTILE
DOWNLOADABLES
Attorney Docket Number:: ELG-P-9139US2
Request for Early Publication?:: No
Request for Non-Publication?:: No
Suggested Drawing Figure:: 3
Total Drawing Sheets:: 10
Small Entity:: No
Petition included?:: No
Secrecy Order in Parent Appl.?:: No

Applicant Information

Applicant Authority type:: Inventor
Primary Citizenship Country: Israel
Status:: Full Capacity
Given Name:: Yigal Mordechai
Family Name:: Edery
City:: Pardesia
Country: Israel
Postal or Zip Code:: 42815
Citizenship Country:: Israel

Applicant Authority type:: Inventor
Primary Citizenship Country: Israel
Status:: Full Capacity .

Given Name:: Nimrod Itzhak
Family Name:: Vered
City:: Goosh Tel-Mond
Country: Israel
Postal or Zip Code:: 40695
Citizenship Country:: Israel

Applicant Authority type:: Inventor
Primary Citizenship Country: USA
Status:: Full Capacity
Given Name:: David R.
Family Name:: Kroll
City:: San Jose
State:: California
Country: USA
Postal or Zip Code:: 96134
Citizenship Country:: USA

Applicant Authority type:: Inventor
Primary Citizenship Country: Israel
Status:: Full Capacity
Given Name:: Shlomo
Family Name:: Touboul
City:: Kefar-Haim
Country: Israel
Postal or Zip Code:: 42945
Citizenship Country:: Israel

Correspondence Information

Correspondence customer number:: 43214

Representative Information

Representative Designation::	Registration number::	Name::
Primary	31575	Andrew L. Tiajolloff
Associate	43116	Vladimir Sherman

Domestic Priority Information

Application::	Continuity Type:	Parent Application::	Parent Filing Date::
This Application	<i>Continuation of</i>	09/861,229	05/17/2001
09/861,229	<i>An application claiming the benefit under 35 USC 119(e)</i>	60/205,591	05/17/2000
09/861,229	<i>Continuation-in-part of</i>	09/551,302	04/18/2000
09/861,229	<i>Continuation-in-part of</i>	09/539,667	03/30/2000
09/539,667	<i>Continuation of</i>	08/964,388	11/06/1997

Under the Paperwork Reduction Act of 1995, no persons are required to respond to a collection of information unless it contains a valid OMB control number.

Substitute for form 1449/PTO INFORMATION DISCLOSURE STATEMENT BY APPLICANT (Use as many sheets as necessary)			Complete if Known			
			Application Number	Unassigned		
			Filing Date	Unassigned		
			First Named Inventor	Yigal Edery		
			Art Unit	Unassigned		
			Examiner Name	Unassigned		
Sheet	1	of	1	Attorney Docket Number	ELG-P-9139-US2	

U. S. PATENT DOCUMENTS					
Examiner Initials*	Cite No. ¹	Document Number	Publication Date MM-DD-YYYY	Name of Patentee or Applicant of Cited Document	Pages, Columns, Lines, Where Relevant Passages or Relevant Figures Appear
		Number-Kind Code ² (if known)			
		US- 5,983,348	11-09-1999	Ji	
		US- 5,974,549	10-26-1999	Golan	
		US- 6,167,520	12-26-2000	Touboul	
		US-			
		US-			
		US-			
		US-			
		US-			
		US-			
		US-			
		US-			
		US-			
		US-			
		US-			
		US-			
		US-			
		US-			
		US-			

FOREIGN PATENT DOCUMENTS						
Examiner Initials*	Cite No. ¹	Foreign Patent Document	Publication Date MM-DD-YYYY	Name of Patentee or Applicant of Cited Document	Pages, Columns, Lines, Where Relevant Passages Or Relevant Figures Appear	T ⁶
		Country Code ³ Number ⁴ Kind Code ⁵ (if known)				

Examiner Signature	Date Considered
--------------------	-----------------

*EXAMINER: Initial if reference considered, whether or not citation is in conformance with MPEP 609. Draw line through citation if not in conformance and not considered. Include copy of this form with next communication to applicant. ¹ Applicant's unique citation designation number (optional). ² See Kinds Codes of USPTO Patent Documents at www.uspto.gov or MPEP 901.04. ³ Enter Office that issued the document, by the two-letter code (WIPO Standard ST.3). ⁴ For Japanese patent documents, the indication of the year of the reign of the Emperor must precede the serial number of the patent document. ⁵ Kind of document by the appropriate symbols as indicated on the document under WIPO Standard ST.16 if possible. ⁶ Applicant is to place a check mark here if English language Translation is attached.

This collection of information is required by 37 CFR 1.97 and 1.98. The information is required to obtain or retain a benefit by the public which is to file (and by the USPTO to process) an application. Confidentiality is governed by 35 U.S.C. 122 and 37 CFR 1.14. This collection is estimated to take 2 hours to complete, including gathering, preparing, and submitting the completed application form to the USPTO. Time will vary depending upon the individual case. Any comments on the amount of time you require to complete this form and/or suggestions for reducing this burden, should be sent to the Chief Information Officer, U.S. Patent and Trademark Office, P.O. Box 1450, Alexandria, VA 22313-1450. DO NOT SEND FEES OR COMPLETED FORMS TO THIS ADDRESS. SEND TO: Commissioner for Patents, P.O. Box 1450, Alexandria, VA 22313-1450.

If you need assistance in completing the form, call 1-800-PTO-9199 (1-800-786-9199) and select option 2.

Under the Paperwork Reduction Act of 1995, no persons are required to respond to a collection of information unless it displays a valid OMB control number.

PATENT APPLICATION FEE DETERMINATION RECORD
Substitute for Form PTO-875 Effective December 8, 2004

Application or Docket Number
11370114

APPLICATION AS FILED - PART I

FOR	NUMBER FILED (Column 1)	NUMBER EXTRA (Column 2)
BASIC FEE (37 CFR 1.16(c), (d), or (e))	N/A	N/A
SEARCH FEE (37 CFR 1.16(d), (e), or (f))	N/A	N/A
EXAMINATION FEE (37 CFR 1.16(g), (h), or (i))	N/A	N/A
TOTAL CLAIMS (37 CFR 1.16(j))	75	minus 20 = 55
INDEPENDENT CLAIMS (37 CFR 1.16(k))	21	minus 3 = 18
APPLICATION SIZE FEE (37 CFR 1.16(l))	If the specification and drawings exceed 100 sheets of paper, the application size fee due is \$250 (\$125 for small entity) for each additional 50 sheets or fraction thereof. See 35 U.S.C. 41(a)(1)(G) and 37 CFR 1.16(s).	
MULTIPLE DEPENDENT CLAIM PRESENT (37 CFR 1.16(m))		

SMALL ENTITY

RATE (\$)	FEE (\$)
N/A	150.00
N/A	\$250
N/A	\$100
X\$ 25 =	
X100 =	
+180=	
TOTAL	

OR OTHER THAN SMALL ENTITY

RATE (\$)	FEE (\$)
N/A	300.00
N/A	\$500
N/A	\$200
X\$50 =	2750
X200 =	3600
+360=	
TOTAL	7350

* If the difference in column 1 is less than zero, enter "0" in column 2.

APPLICATION AS AMENDED - PART II

03-07-06

	(Column 1)	(Column 2)	(Column 3)
AMENDMENT A	CLAIMS REMAINING AFTER AMENDMENT	HIGHEST NUMBER PREVIOUSLY PAID FOR	PRESENT EXTRA
	Total (37 CFR 1.16(j))	75 Minus 20	55
	Independent (37 CFR 1.16(k))	20 Minus 3	17
	Application Size Fee (37 CFR 1.16(l))		
FIRST PRESENTATION OF MULTIPLE DEPENDENT CLAIM (37 CFR 1.16(m))			

SMALL ENTITY

RATE (\$)	ADDITIONAL FEE (\$)
X\$ 25 =	
X100 =	
+180=	
TOTAL ADD'L FEE	

OR OTHER THAN SMALL ENTITY

RATE (\$)	ADDITIONAL FEE (\$)
X\$50 =	0
X200 =	0
+360=	
TOTAL ADD'L FEE	0

	(Column 1)	(Column 2)	(Column 3)
AMENDMENT B	CLAIMS REMAINING AFTER AMENDMENT	HIGHEST NUMBER PREVIOUSLY PAID FOR	PRESENT EXTRA
	Total (37 CFR 1.16(j))	Minus	
	Independent (37 CFR 1.16(k))	Minus	
	Application Size Fee (37 CFR 1.16(l))		
FIRST PRESENTATION OF MULTIPLE DEPENDENT CLAIM (37 CFR 1.16(m))			

SMALL ENTITY

RATE (\$)	ADDITIONAL FEE (\$)
X\$ 25 =	
X100 =	
+180=	
TOTAL ADD'L FEE	

OR OTHER THAN SMALL ENTITY

RATE (\$)	ADDITIONAL FEE (\$)
X\$50 =	
X200 =	
+360=	
TOTAL ADD'L FEE	

- * If the entry in column 1 is less than the entry in column 2, write "0" in column 3.
- ** If the "Highest Number Previously Paid For" IN THIS SPACE is less than 20, enter "20".
- *** If the "Highest Number Previously Paid For" IN THIS SPACE is less than 3, enter "3".

The "Highest Number Previously Paid For" (Total or Independent) is the highest number found in the appropriate box in column 1.

This collection of information is required by 37 CFR 1.16. The information is required to obtain or retain a benefit by the public which is to file (and by the USPTO to process) an application. Confidentiality is governed by 35 U.S.C. 122 and 37 CFR 1.14. This collection is estimated to take 12 minutes to complete, including gathering, preparing, and submitting the completed application form to the USPTO. Time will vary depending upon the individual case. Any comments on the amount of time you require to complete this form and/or suggestions for reducing this burden, should be sent to the Chief Information Officer, U.S. Patent and Trademark Office, U.S. Department of Commerce, P.O. Box 1450, Alexandria, VA 22313-1450. DO NOT SEND FEES OR COMPLETED FORMS TO THIS ADDRESS. SEND TO: Commissioner for Patents, P.O. Box 1450, Alexandria, VA 22313-1450.

If you need assistance in completing the form, call 1-800-PTO-9199 and select option 2.