



US008694657B1

(12) **United States Patent Marks**

(10) **Patent No.:** US 8,694,657 B1
(45) **Date of Patent:** *Apr. 8, 2014

(54) **REAL TIME COMMUNICATIONS SYSTEM**
(76) Inventor: **Daniel L Marks**, Chappel Hill, NC (US)
(*) Notice: Subject to any disclaimer, the term of this patent is extended or adjusted under 35 U.S.C. 154(b) by 0 days.
This patent is subject to a terminal disclaimer.

5,408,470 A	4/1995	Rothrock et al.	
5,440,624 A *	8/1995	Schoof, II	379/202.01
5,452,299 A	9/1995	Thessin et al.	
5,465,370 A	11/1995	Ito et al.	709/204
5,471,318 A	11/1995	Ahuja et al.	386/125
5,491,743 A	2/1996	Shiio et al.	709/204
5,528,671 A	6/1996	Ryu et al.	
5,548,506 A	8/1996	Srinivasan	
5,563,804 A	10/1996	Mortensen et al.	
5,572,248 A	11/1996	Allen et al.	348/14.1
5,572,643 A	11/1996	Judson	709/218
5,592,478 A	1/1997	Weiss	370/260
5,608,786 A	3/1997	Gordon	
5,613,056 A	3/1997	Gasper et al.	345/473
5,616,876 A	4/1997	Cluts	84/609

(21) Appl. No.: **09/399,578**
(22) Filed: **Sep. 20, 1999**

(Continued)

Related U.S. Application Data

(63) Continuation of application No. 08/617,658, filed on Apr. 1, 1996, now Pat. No. 5,956,491.
(51) **Int. Cl.**
G06F 15/16 (2006.01)
(52) **U.S. Cl.**
USPC **709/229; 709/204; 709/206; 709/207; 709/225**
(58) **Field of Classification Search**
USPC 709/203, 231, 316, 204-207, 225, 229; 379/401, 202.01
See application file for complete search history.

FOREIGN PATENT DOCUMENTS

EP 336 552 A2 10/1989

OTHER PUBLICATIONS

Kazuo Watabe et al., Distributed Multiparty Desktop Conferencing System: MERMAID, Oct. 1990, Proceedings CSCW '90, ACM, pp. 27-38.*

(Continued)

Primary Examiner — Patrice Winder
(74) Attorney, Agent, or Firm — Peter K. Trzyna, Esq.

(56) **References Cited**

U.S. PATENT DOCUMENTS

4,525,779 A	6/1985	Davids et al.	
4,710,917 A	12/1987	Tompkins et al.	709/204
4,953,159 A	8/1990	Hayden et al.	370/265
5,008,853 A	4/1991	Bly et al.	
5,195,086 A	3/1993	Baumgartner et al.	370/264
5,257,306 A	10/1993	Watanabe	348/14.09
5,325,419 A	6/1994	Connolly et al.	379/60
5,333,266 A	7/1994	Boaz et al.	
5,347,306 A	9/1994	Nitta	348/14.1
5,347,632 A	9/1994	Filepp et al.	

(57) **ABSTRACT**

A system and method communicating via an Internet network, the system including: a plurality of computers connected to a computer system such that one of the plurality of computers, corresponding to a first of the user identities, and an other of the plurality of computers, corresponding to a second of the user identities, can send communications, and some of the communications are received in real time via the Internet. There can be a determination as to whether some of the communications are allowed.

671 Claims, 22 Drawing Sheets

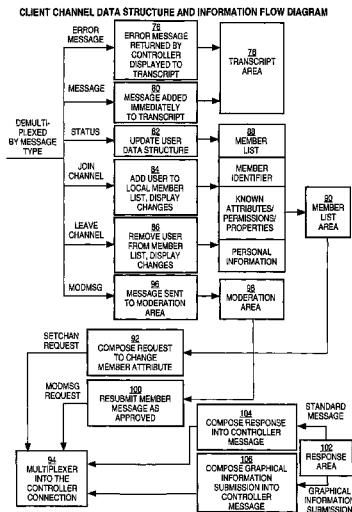

(56)

References Cited

U.S. PATENT DOCUMENTS

5,617,539	A	4/1997	Ludwig et al.	709/205
5,621,727	A	4/1997	Vaudreuil	
5,627,978	A	5/1997	Altom et al.	715/758
5,659,692	A	8/1997	Poggie et al.	
5,682,469	A	10/1997	Linnett et al.	345/473
5,689,553	A *	11/1997	Ahuja et al.	370/352
5,713,019	A	1/1998	Keaten	707/10
5,721,763	A	2/1998	Joseph et al.	379/88.04
5,724,508	A	3/1998	Harple, Jr. et al.	
5,729,684	A	3/1998	Kuzma	709/204
5,740,231	A	4/1998	Cohn et al.	
5,754,775	A	5/1998	Adamson et al.	709/204
5,761,201	A	6/1998	Vaudreuil	
5,771,355	A	6/1998	Kuzma	395/200.62
5,774,668	A	6/1998	Choquier et al.	709/223
5,784,568	A	7/1998	Needham	709/234
5,793,365	A *	8/1998	Tang et al.	715/758
5,794,006	A	8/1998	Sandermah	709/223
5,794,210	A	8/1998	Goldhaber et al.	705/14
5,799,151	A *	8/1998	Hoffer	709/204
5,801,700	A	9/1998	Ferguson	715/748
5,802,281	A	9/1998	Clapp et al.	709/228
5,812,552	A *	9/1998	Arora et al.	370/401
5,822,523	A	10/1998	Rothschild et al.	709/236
5,826,085	A *	10/1998	Bennett et al.	709/316
5,832,212	A	11/1998	Cragun et al.	395/188.01
5,850,442	A	12/1998	Mulfic	705/65
5,880,731	A	3/1999	Liles et al.	715/758
5,889,843	A	3/1999	Singer et al.	379/202.01
5,894,321	A *	4/1999	Downs et al.	370/260
5,894,556	A	4/1999	Grimm et al.	
5,924,082	A	7/1999	Silverman et al.	705/37
5,933,599	A	8/1999	Nolan	715/734
5,941,947	A *	8/1999	Brown et al.	709/225
5,951,694	A	9/1999	Choquier et al.	
5,956,509	A	9/1999	Kevner	719/330
5,960,173	A	9/1999	Tang et al.	
5,974,409	A	10/1999	Sanu et al.	707/3
5,987,401	A	11/1999	Trudeau	704/2
6,064,723	A	5/2000	Cohn et al.	
6,119,101	A	9/2000	Peckover	
6,289,390	B1	9/2001	Kavner	
6,560,707	B2 *	5/2003	Curtis et al.	713/163
6,692,359	B1	2/2004	Williams et al.	463/42
8,407,356	B1	3/2013	Marks	

OTHER PUBLICATIONS

Tak K Woo and Michael J. Rees, A Synchronous Collaboration Tool for the World Wide Web, The Proceedings of Second International WWW Conference: Mosaic and the Web, Jul. 1994, 10 pages.*

Vinod Anupam et al., SHASTRA—An architecture for Development of Collaborative Applications, Apr. 1993, IEEE, pp. 155-166.*

Paul Tarau et al., LogiMOO: an Extensible Multi-User Virtual World with Natural Language Control, The Journal of Logic Programming, 1993, vol. 12, pp. 1-23.*

"Microsoft NetMeeting Conferencing Software Provides Easy Voice, Dad Internet Communications; Available on the Web Now", May 29, 1996, <http://www.microsoft.com/presspass/press/1996/may96/INCONFPR.asp>.

"Mechanisms for Specifying and Describing the Format of Internet Message Bodies", Nathaniel Borenstein, Ned Freed, Jun. 1991, pp. 1-40.

"Network Security via Private-Key Certificates", Don Davis and Ralph Swick, pp. 1-4, Oct. 1990.

"Discuss in Section 9", Athena Zepher and Kerberos, 1988, pp. 1-11.

"www.cs.columbia.edu/~hgs/rpt/" complete printout of website, compiled Feb. 3, 2002.

"History of IRC", Daniel Stenberg, Version: 0.7—Jan. 8, 2002.

"Index of /pub/academic/communications/logs/Gulf-War/", www.ibiblio.org/pub/academic/communications/logs/Gulf-War/desert-storm/01, retrieved May 2, 2002.

"Join a Dungeon Adventure", Daniel James, Nov. 30, 2001, www.techtv.com/screensavers/supergeek/story/0,24330,3012300,00.html.

"Google Search Results for MUDs", Google.com, <http://directory.google.com/Top/Games/Internet/MUDs/>, retrieved May 5, 2002.

"A Brief History of SOF", <http://sofeq.sofguild.com/history.htm>, Jun. 1998.

"Adventures On-Line", Michael Ciralo, www.atarimagazines.com/v2n7/online.html, Antic vol. 3, No. 7, Nov. 1984.

"Host Extensions for IP Multicasting," S. Deering, Stanford University, Aug. 1989, 16 Pages.

"Complaint: Brian Hollander vs. Peter K. Trzyna and PTK Technologies, LLC," Dated Nov. 13, 2007, pp. 1-18.

Winder, Patrice L., "Notice of Allowance" mailed Mar. 21, 2013, for U.S. Appl. No. 11/510,351, filed Aug. 24, 2006, pp. 1-26. USA.

Trzyna, Peter K., "Amendment After Allowance" filed Mar. 22, 2013, for U.S. Appl. No. 11/510,351, filed Aug. 24, 2006, pp. 1-22. USA.

Winder, Patrice L., "Office Action-Final Rejection" mailed Jan. 10, 2013, for U.S. Appl. No. 11/510,473, filed Aug. 24, 2006, pp. 1-37. USA.

Trzyna, Peter K., "Amendment After Final and Response" filed Sep. 6, 2012, for U.S. Appl. No. 11/510,473, filed Aug. 24, 2006, pp. 1-30. USA.

Winder, Patrice L., "Notice of Allowance" mailed Apr. 5, 2013, for U.S. Appl. No. 11/510,463, filed Aug. 24, 2006, pp. 1-23. USA.

Trzyna, Peter K., "Amendment After Allowance" filed Apr. 5, 2013, for U.S. Appl. No. 11/510,463, filed Aug. 24, 2006, pp. 1-18. USA.

Trzyna, Peter K., "Supplemental Amendment and Response After Final" filed Mar. 12, 2013, for U.S. Appl. No. 11/510,463, filed Aug. 24, 2006, pp. 1-18. USA.

Prakash, Atul et al. "Distview: Support for Building Efficient Collaborative Applications using Replicated Objects." Software Systems Research Laboratory, Department of Electrical Engineering and Computer Science, University of Michigan, pp. 1-12, Ann Arbor, MI.

Anupam, Vinod "Collaborative Multimedia Environments for Problem Solving." A Thesis Submitted to Purdue University. (Aug. 1994), pp. 1-212, Ann Arbor, MI.

Bajaj, Chandrajit et al. "Collaborative Multimedia in Shastra." 3rd International Conference on Multimedia, San Francisco, CA (1995), pp. 365-366.

Ahuja, S.R. et al. "The Rapport Multimedia Conferencing System." AT&T Bell Laboratories, pp. 1-8. Holmdel, NJ.

Anupam, Vinod et al. "Collaborative Multimedia in Scientific Design." Proceedings: First ACM Multimedia Conference, ACM Multimedia 93, Anaheim, California, ACM Press, (1993), pp. 447-456.

Anupam, Vinod et al. "Shastra—An Architecture for Development of Collaborative Applications." Proceedings: Second IEEE Workshop on Enabling Technologies: Infrastructure for Collaborative Enterprises, Morgantown, (1993), pp. 155-166.

Bajaj, Chandrajit et al. "Brokered Collaborative Infrastructure for CSCW." Proceedings: Fourth IEEE Workshop on Enabling Technologies: Infrastructure for Collaborative Enterprises, Berkeley Springs, West Virginia, IEEE Computer Society Press, (1995), pp. 207-213.

Anupam, Vinod et al. "Shastra: Multimedia Collaborative Design Environment." IEEE Multimedia, 1, 2, (1994), pp. 39-49.

Anupam, Vinod et al. "Distributed and Collaborative Visualization." IEEE Computer, 27, 7, (Jul. 1994), pp. 37-43.

Bajaj, Chandrajit et al. "Web based Collaborative Visualization of Distributed and Parallel Simulation." In Proceedings of the 1999 IEEE Symposium on Parallel Visualization and Graphics, (Oct. 24-29, 1999), San Francisco, CA, pp. 47-54.

Bajaj, Chandrajit et al. "NLS: Collaborative Virtual Environment to Promote Shared Awareness." Proceedings: Workshop on New Paradigms in Information Visualization and Manipulation NPIV'96, In conjunction with Fifth ACM International Conference on Information and Knowledge Management (CIKM'96), (1996), pp. 41-45.

Bajaj, Chandrajit et al. "Web Based Collaboration-Aware Synthetic Environments" Proceedings of the 1997 GVU/NIST TEAMCAD workshop, Atlanta, GA, 1997, 143-150.

(56)

References Cited

OTHER PUBLICATIONS

- Trzyna, Peter K., "Amendment After Final and Request for Reconsideration" filed Jan. 16, 2013, for U.S. Appl. No. 11/836,633, filed Aug. 9, 2007, pp. 1-14. USA.
- Trzyna, Peter K., "Amendment and Request for Reconsideration" filed Jul. 16, 2012, for U.S. Appl. No. 11/510,351, filed Aug. 24, 2006, pp. 1-32. USA.
- T. Socolofsky et al., Request for Comments (RFC) 1180: A TCP/IP Tutorial, Network Working Group, Jan. 1991, pp. 1-29.
- J. Oikarinen et al., Request for Comments (RFC) 1459: Internet Relay Chat Protocol, Network Working Group, May 1993, pp. 1-66.
- Andreas Dieberger, Providing Spatial Navigation for the World Wide Web, Spatial Information theory a Theoretical Basis for GIS, Lecture Notes in Computer Science, vol. 988, 1995, pp. 93-106.
- Lee Newberg et al., Integrating the World-Wide Web and Multi-User Domains to Support Advanced Network-Based Learning Experiments, Conference Proceedings of ED-MEDIA 1995, pp. 494-499.
- TY Hou et al., An active multimedia System for Delayed Conferencing, Proceedings of the SPIE Conference on High-Speed Networking and Multimedia Computing, San Jose CA, 1994, pp. 97-104.
- Roy Rada and Claude Ghaoui. "Medical Multimedia" Intellect Ltd. Great Britain (1995) Suite 2, 108/110 London Road, Oxford OX3 9AW.
- "CCCP: Conference Control Channel Protocol a Scalable Base for Building Conference Control Applications," Mark Handley et al., V1.4 pp. 1-18, Aug. 28-Sep. 1, 1995.
- "CCCP: Conference Control Channel Protocol a Scalable Base for Building Conference Control Applications," Mark Handley et al., pp. 1-13, Aug. 28-Sep. 1, 1995.
- "An Application Level Video Gateway," Elan Amir et al., pp. 1-10, Aug. 28-Sep. 1, 1995.
- "Vic: A Flexible Framework for Packet Video," Steven McCanne, et al. pp. 1-12. Aug. 28-Sep. 1, 1995.
- "Argo: A System for Distributed Collaboration," Hania Gajewska, et al., 8 pages, ACM Multimedia 1994.
- "Scalable Feedback Control for Multicast Video Distribution in the Internet," Jean-Chrysostome Bolot, et al., 10 Pages, Proceedings of SIGCOMM '94, ACM.
- "Argohalls: Adding Support for Group Awareness to the Argo Telecollaboration System," Hania Gajewska, et al., 2 Pages, Nov. 13-17, 1995.
- "PSSST: Side Conversations in the Argo Telecollaboration System," Lance Berc, et al. 2 Pages. Nov. 14-17, 1995.
- "A World-Wide Web User Interface for an Electronic Meeting Tool," Michael J. Rees and Tak K. Woo, Howard & Lueng, Nov. 28-Dec. 1, 1994, pp. 187-192.
- Rules for IRC networking—Ratified Jul. 6, 1994; Edited Jun. 29 by #EU-Opers.
- IRC—Internet Relay Chat, doc/MANUAL; Copyright 1990, Karl Kleinpaste.
- Undemet IRC FAQ (Part I).(updated Jul. 28, 1995)—Weekly Report.
- Undemet IRC FAQ (Part II)(updated Jul. 28, 1995)—Weekly Report.
- A short IRC primer; Edition 1.1b, Feb. 28, 1993.
- Internet Relay Chat Protocol; J. Oikarinen, D. Reed; May 1993.
- Electropolis: Communication and Community on Internet Relay Chat; Elizabeth M. Reid 1991.
- CU-SeeMe, Updated: Thursday Dec. 21, 1995.
- Real Time Groupware on the Information Highway, Saul Greenberg, Department of Computer Science, University of Calgary, Alberta Canada (1994).
- Real Time Groupware as a Distributed System: Concurrently Control and Its Effect on the the Interface, Saul Greenberg and David Marwood, Department of Computer Science, University of Calgary, Alberta Canada (1994).
- A Groupware Environment for Complete Meetings, Ted O'Grady and Saul Greenberg, The University of Calgary, Alberta Canada (1992).
- Group Kit a Groupware Toolkit for Building Real-Time Conferencing Applications, Mark Roseman and Saul Greenberg, Department of Computer Science, University of Calgary, Alberta Canada, CSCW 92 Proceedings (1992).
- Issues and Experiences Designing and Implementing Two Group Drawing Tools. Saul Greenberg, Mark Roseman, David Webster and Ralph Bohnet, Department of Computer Science, University of Calgary, Alberta Canada (1992).
- Liveware: A New Approach to Sharing Data in Social Networks, Ian H. Witten, Computer Science, University of Calgary, Canada, Harold W. Thimbleby, Computing Science, Stirling University, Stirling, Scotland, UK, George Coulouris, Queen Mary and Westfield Collette, London, Saul Greenberg. Computer Science, University of Calgary, Calgary, Canada (Received May 1, 1990 and accepted in revised form Aug. 1, 1990).
- Groupsketch: A Multi-User Sketchpad for Geographically-Distributed Small Groups, Saul Greenberg, Department of Computer Science, University of Calgary, Alberta Canada, Ralph Bohnet, MPR TelTech Ltd., Burnaby, Canada, CSCW (1991(b)).
- The World Wide Web Unleashed, John December and Neil Randall, SAMS Publishing, Indianapolis, IN, (1994).
- Plato: The Emergence of On-Line Community, Copyright 1994 by David R. Woolley, Matrix News, vol. 4, No. 1, (1994).
- Gtalk Owners Manual, David W. Jeske (1995).
- Muds Grow Up: Social Virtual Reality in the Real World; Pavel Curtis and David A. Nichols, Xerox Parc (1993).
- Collaborative Networked Communication: MUDS as Systems Tools, Remy Evard, 1993 Lisa, Nov. 1-5, 1993.
- Proceedings of the Seventh Systems Administration Conference (USA VII), Monterey, CA, USENIX Association, (1993) (One Page).
- The History of NWN, Neverwinter Nights Archive (1991-1997), netgames™ Your Guide to the Games People Play on the Electronic Highway, A Michael Wolff Book, Kelly Maloni, Derek Baker and Nathaniel Wice.
- Baudy Tales From The Cyburbs: A Guide to On-Line Games, (includes related articles on UseNet Message Groups and Suggested reading (Evaluation) (Software Review), Full Text: Copyright 1994 zdnet, Computer Gaming World, v 123 (1994).
- AMS: Area Message Service for SLC. M. Crane, R. Mackenzie, D. Millsom, M. Zelazny, Stamford Linear Accelerator Center, Stanford University, Stanford, CA, PAC (1993).
- An Experimental Multi-Media Bridging System, E.J. Addeo, A.B. Dayao, A.D. Gelman, V.F. Massa, Bell Communications Research, Morristown, NJ, ACM (1988).
- Quilt: A Collaborative Tool for Cooperative Writing, Robert S. Fish, Robert E. Kraut, Mary D. P. Leland, Bell Communications Research, Michael Cohen, University of Washington, ACM (1988).
- RFC 1459 Internet Relay Chat Protocol, J. Oikarinen, D. Reed (1993).
- Groupware for Real-Time Drawing—A Designer's Guide, Saul Greenberg, Stephen Hayne, Roy Rada, McGraw-Hill Book Company, Berkshire, England (1995).
- Collaborative Document Production Using Quilt, Mary D.P. Leland, Robert S. Fish and Robert E. Kraut, Bell Communications Research, Inc, Morristown, NJ ACM (1988).
- The Rapport Multimedia Conferencing System, S.R. Ahuja, J. Robert Ensor and David N. Horn, AT&T Bell Laboratories, Holmdel, NJ, ACM (1988).
- Software Architecture for Integration of Video Services in the Etherphone System, P. Venkat Rangan, Member, IEEE, and Daniel C. Swinehart, Member, IEEE (1991).
- Multimedia Conferencing in the Etherphone Environment, Herrick V. Vin, Polle T. Zellweger, Daniel C. Swinehart, and P. Venkat Rangan, Xerox Palo Alto Research Center, (1991).
- Tools for Supporting the Collaborative Process, James R. Rhyne, Catherine G. Wolf, IBM Thomas J. Watson Research Center, Yorktown Heights, NY, UIST (1992).
- System Support for Computer Multimedia Collaborations, Harrick M. Vin, P. Venkrat Rangan, University of California at San Diego, LaJolla, CA, Mon-Song Chen, IBM T. J. Watson Research Center, Yorktown Heights, NY, CSCW 92 Proceedings (1992).

(56)

References Cited

OTHER PUBLICATIONS

- Collaboration in KMS, A Shared Hypermedia System, Elise Yoder, Robert Aksyn, Donald McCracken, Knowledge Systems Incorporated, Murrysville, PA, ACM (1989).
- The Rendezvous Architecture and Language for Constructing Multiuser Applications, Ralph D. Hill, Tom Brinck, Steven Rohall, John F. Patterson and Wayne Wilner, ACM Transactions on Computer-Human Interaction, vol. 1, No. 2 (1994).
- Collaboration Support Provisions in Augment, Douglas C. Engelbart, Tymshare, Inc. (1983).
- Building Real-Time Groupware With Groupkit, A Groupware Toolkit, Mark Roseman and Saul Greenberg, University of Calgary, ACM Transactions on Computer-Human Interaction, vol. 3, No. 1, (1996).
- Architecture for a Multimedia Teleconferencing System, L. Aguilar, J.J. Garcia-Luna-Aceves, D. Moran, E.J. Craighill, R. Brungardt, Information Services and Technology Center, SSRI International, Menlo Park, CA, ACM (1986).
- Special Issue on CSCW: Part 1, Human and Technical Factors of Distributed Group Drawing Tools, Saul Greenberg, Mark Roseman, Dave Webster and Ralph Bohnet, Interacting With Computers, vol. 4, No. 3 (1992).
- Design of a Multi-Media Vehicule for Social Browsing, Robert W. Root, Bell Communications Research, NJ, ACM (1988).
- Supporting Collaborative Writing of Hyperdocuments in Sepia, Jorg M. Haake and Brian Wilson, GMD-IPSI, Federal Republic of Germany, CSCW 92 Proceedings (1992).
- Filling Html Forms Simultaneously: Coweb-Architecture and Functionality, Stephen Jacobs, Michael Gebhardt, Stefanie Kethers, Wojtek Rzasa, RWTH Aachen, Informatik V, Fifth International World Wide Web Conference, Paris, France (May 1996).
- Webchat 0.2 Source Distribution, e-mail from Michael Fremont, Internet Roundtable Society, dated Feb. 10, 1995.
- Supporting Development of Synchronous Collaboration Tools on the Web With Groco, Michael Walther, Proceedings of the ERCIM workshop on CSCW and the Web, Sankt Augustin, Germany (Feb. 7-9, 1996).
- The University of Calgary, Design of Real-Time Groupware Toolkit, Mark Roseman, A Thesis Submitted to the Faculty of Graduate Studies in Partial Fulfillment of the Requirements for the Degree of Master of Science, Department of Computer Science, Calgary, Alberta (Feb. 1993).
- Session Management for Collaborative Applications, W. Keith Edwards, Graphics, Visualization & Usability Center College of Computing, Georgia Institute of Technology, GA, Association for Computer Machinery, Published in Proceedings of the ACM Conference on Computer-supported Work (CSCW '94).
- Social Activity Indicators: Interface Components for CSCW Systems, Mark S. Ackerman, Brian Starr, Department of Information and Computer Science, University of California, Irvine, UIST (No. 14-17 (1995).
- Social Activity Indicators: Interface Components for CSCW Systems, Symposium on User Interface Software and Technology, Proceedings of the 8th Annual ACM Symposium on User Interface and Software Technology, Pittsburgh, PA (1995).
- Distview: Support for Building Efficient Collaborative Applications Using Replicated Objects, Atul Prakash and Hyong Sop Shim, Software Systems Research Laboratory, Department of Electrical Engineering and Computer Science, University of Michigan, MI ACM (1994).
- Gtalk Source License Agreement, David W. Jeske, Jun. 2, 1998).
- Englebart Douglas C.: "Authorship Provisions in AUGMENT" COMPCON '84 Digest Proceedings of the COMPCON Conference, San Francisco, CA, Feb. 27-Mar. 1, 1984, pp. 465-472.
- Englebart, Douglas C.: "Toward High-Performance Knowledge Workers," OAC '82 Digest, Proceedings of the AFIPS Office Automation Conference, San Francisco, CA, Apr. 5-7, 1982, pp. 279-290.
- Lee, Andrew: "Anonymous collaboration: An alternative technique for working together" ACM SIGCHI Bulletin vol. 26, Issue 3, Jul. 1994, pp. 40-46.
- Abdel-Wahab, Hussein: "Reliable Information Service for Internet Computer Conferencing" Proceedings, Second Workshop on Enabling Technologies Infrastructure for Collaborative Enterprises, IEEE Comput. Soc. Press, 1993, pp. 128-142.
- French, Robert S et al: "The Zephyr Programmer's Manual" Protocol Version ZEPH0.2, Apr. 5, 1989.
- Fermann, Carla J.: "Distributed consulting in a distributed environment" New Centerings in Computing Services, Proceedings of the 18th annual ACM SIGUCCS conference on User services Cincinnati, Ohio, United States, 1990 pp. 117-120.
- Cohen, Abbe: "Inessential Zephyr" The Student Information Processing Board, Aug. 23, 1993.
- French, Robert /mit/zephyr/repository/zephyr/clients/zaway/zaway.c, v \$; Copyright (c) 1987, 1993 by the Massachusetts Institute of Technology.
- Sunkavally, N et al: "Using MIT's Athena Computing System" The Tech, vol. 119, No. 39, Thursday, Sep. 2, 1999.
- Tony Della Fera et al.: "Zephyr—Sephyr Notification Service" MIT Project Athena (Jul. 1, 1988) Zephyr Notification Service.
- Horus: A Flexible Group Communications System, Robbed van Renesse, Kenneth P. Birman, and Silvano Maffei, Communications of the ACN, Apr. 1996, vol. 39, No. 4.
- French Robert S.: "Zaway—tell other people via Zephyr that you aren't around" MIT Project Athena, Jul. 1, 1988.
- Kurlander, David et al: "Comic Chat" Proceedings of SIGGRAPH'96 (New Orleans, Aug. 1996), Computer Graphics Proceedings, Annual Conference Series, pp. 225-236, New York, 1996, ACM SIGGRAPH.
- Maes, P.: "Artificial Life meets Entertainment: Interacting with Life-like Autonomous Agents", In: Special Issue on New Horizons of Commercial and Industrial AI 38, 11 (1995) 108-114, Communications of the ACM, ACM Press.
- Walker, Janet H. et al: "Using a Human Face in an Interface", ACM Human Factors in Computing Systems. Apr. 24-28, 1994 pp. 85-91.
- "Visual Dialog Showing Speech Interaction with an Intelligent Agent" IBM Technical Disclosure Bulletin, vol. 39, No. 1, Jan. 1996, pp. 237-239.
- An Intelligent Network Service Prototype Using Knowledge Processing, Int. Conf. on Tools for AI (1991).
- Julia's Home Page, Julie, a Chatterbot (Dec. 19, 1994).
- Chatterbots, Tnymuds, and the Turing Test, Entering the Loebner Price Competition (Jan. 24, 1994).
- Entertaining Agents: Julia (1993).
- What is an Agent, Anyway? A Sociological Case Study, Leonard N. Foner, (May 1993).
- Social Activity Indicators: Interface Components for CSCW Systems, Mark S. Ackerman and Brian Starr, Dept. of Info. and Computer Science, Univ. of California, Irvine (Nov. 14-17, 1995) UIST '95.
- Software Secretaries: Learning and Negotiating Personal Assistants for the Daily Office Work, Siegfried Bocionek, Siemens AG, Munich, Germany (1994 IEEE).
- MUDs in Education: New Environments, New Pedagogies, Tari Lin Fanderclai, Computer—Mediated Communication Magazine, vol. 2, No. 1, Jan. 1, 1995.
- The Evolution of Intercat-Scale Event Notification Services: Past, Present and Future, Adam Rifkin and Rohit Khare, Aug. 10, 1998.
- The Zephyr Help Assistance: Promoting Ongoing Activity in a CSCW System; Mark Ackerman and Laysia Palen, Department of Information and Computer Science, University of California, Irvine (to appear in the Proceedings of the ACM Conference on Human Factors in Computing Systems (CHI '96)).
- The Zephyr Notification Service, C. Anthony DellaFera et al., Digital Equipment Corp., Project Athena, Massachusetts Institute of Technology, Cambridge, MA, 1996.
- Windy City Innovations, LLC v. America Online, Inc.*, Civil Action No. 04 C 4240, "Complaint" filed Jun. 24, 2004.
- Windy City Innovations, LLC v. America Online, Inc.*, Civil Action No. 04 C 4240, "Notice of Claim Involving a Patent" filed Jun. 24, 2004.
- Windy City Innovations, LLC v. America Online, Inc.*, Civil Action No. 04 C 4240, "First Amended Answer to the Complaint, and Counterclaim of Defendant America Online, Inc." filed Sep. 14, 2004.

(56)

References Cited

OTHER PUBLICATIONS

Windy City Innovations, LLC v. America Online, Inc., Civil Action No. 04 C 4240, "Plaintiff's Reply to the First Amended Counterclaim of Defendant America Online, Inc." filed Sep. 28, 2004.

Windy City Innovations, LLC v. America Online, Inc., Civil Action No. 04 C 4240, "AOL's Supplemental Response to Plaintiff Windy City Innovations, LLC's First Set of Interrogatories (No. 4)" dated Apr. 29, 2005.

"Internet hasn't focused on good photography as much as it could" Article, The Dallas Morning News, Sep. 1995 (AOL-B 0001478).

"Group dynamics add fun to guided online tours" Article, USA Today, Oct. 1995 (AOL-B 0001479).

"People with addictions band together for support on line", Article, Jun. 1995 (AOL-B 0001480).

"Netscape Communications Introduces Netscape Internet Applications Family for Electronic Commerce" Netscape Company Press Relations, Mar. 1995 (AOL-B 0005712-0005713).

Windy City Innovations, LLC v. America Online, Inc., Civil Action No. 04 C 4240, "Expert Report of Bruce M. Maggs" dated Aug. 5, 2005.

Windy City Innovations, LLC v. America Online, Inc., Civil Action No. 04 C 4240, "Supplemental Rebuttal Expert of Bruce M. Maggs Regarding Invalidity of U.S. Patent 5,956,491" dated Sep. 26, 2005.

Windy City Innovations, LLC v. America Online, Inc., Civil Action No. 04 C 4240, Rebuttal Expert Report of Bruce M. Maggs Regarding Invalidity of U.S. Patent 5,956,491 dated Aug. 28, 2005.

Windy City Innovations, LLC v. America Online, Inc., Civil Action No. 04 C 4240, AOL's Supplemental Response to Plaintiff Windy City Innovations, LLC's First Set of Interrogatories (No. 4) dated Apr. 29, 2005.

Windy City Innovations, LLC v. America Online, Inc., Civil Action No. 04 C 4240, AOL's Second Supplemental Response to Plaintiff Windy City Innovations, LLC's First Set of Interrogatories (No. 4) dated May 20, 2005.

Windy City Innovations, LLC v. America Online, Inc., Civil Action No. 04 C 4240, AOL's Third Supplemental Response to Plaintiff Windy City Innovations, LLC's First Set of Interrogatories (No. 4) dated Aug. 11, 2005.

Windy City Innovations, LLC v. America Online, Inc., Civil Action No. 04 C 4240, AOL's Fourth Supplemental Response to Plaintiff Windy City Innovations, LLC's First Set of Interrogatories (No. 4) dated Sep. 20, 2005.

Windy City Innovations, LLC v. America Online, Inc., Civil Action No. 04 C 4240, AOL's Fifth Supplemental Response to Plaintiff Windy City Innovations, LLC's First Set of Interrogatories (No. 4) dated Sep. 27, 2005.

Windy City Innovations, LLC v. America Online, Inc., Civil Action No. 04 C 4240, "Declaration of Mr. David W. Jeske" dated Jun. 6, 2005.

"Netscape adds tools," Responsive Database Services, Inc., Press Release Mar. 1995 (AOL 1206861-1206862).

"Netscape communications introduces Netscape interne applications family for electronic commerce," PR Newswire Association Inc. Press Release, Mar. 1995 (AOL 1206863-1206864).

Full Scale Commerce With Netscape, Business Communications Co., Press Release, Apr. 1995 (AOL 1206865-1206866).

"Netscape spins Web extensions; adds firewall, Usenet servers, electronic shopping software Netscape Communications Proxy Server, Isore, Merchant System, Publishing System, Community System," Information Access Company, Apr. 1995 (AOL 1206867-1206868).

"Netscape offers bookmark, chat services on Web," InfoWorld Media Group, Aug. 1995 (AOL 1206869).

"Netscape for Windows 95 Announced," Newsweek Business Information, Inc., Aug. 1995 (AOL 1206870-1206873).

"Netscape introduces Netscape Smartmarks and Netscape Chat; Applications Bring New Navigation and Communications Capabilities to Users of Netscape Navigator for Windows," Netscape Chat Help Contents (AOL 613173-613243).

Windy City Innovations, LLC v. America Online, Inc., Civil Action No. 04 C 4240, "AOL's Second Supplemental Response to Plaintiff Windy City Innovations, LLC's First Set of Interrogatories (No. 4)" dated Mar 20, 2005.

Netscape, "Netscape Power Pack Bookmarks, Chat, and Multimedia Add-Ons". (AOL 613167-613172).

Netscape, "Netscape Announces Add-On Product Suite for Popular Netscape Navigator Software, Netscape Power Pack Includes Netscape SmartMarks, Netscape Chat and Multimedia Add-On Applications From Adobe, Apple, and Progressive Networks" Press Release, May 11, 2005, pp. 1-3. (AOL 613244-613246).

PR Newswire Assoc., Inc. "Netscape Announces Add-On Product Suite for Popular Netscape Navigator Software" Article, Oct. 25, 1999, pp. 1-2. (AOL 613247-613248).

Netscape, "Netscape Chat Help Contents" Manual. (AOL 613173-613243).

Wired Channeling "Tips for Foiling the NSA" Article, Jan. 1996, p. 174. (AOL 469104-469105).

Flash News "Market Support News, Jacksonville Update" Article, May 19, 1995, pp. 1-4, (AOL 469106-469109).

Palfreyman, et al., "A Protocol for User Awareness on the World Wide Web", Article, 1996, pp. 130-139. (AOL 469110-469119).

Robinett, "Interactivity and Individual Viewpoint in Shared Virtual Worlds: The Big Screen vs. Networked Personal Displays", Article, Computer Graphics, vol. 28, No. 2, May 1994, pp. 127-130. (AOL 074871-074974).

Ohya, et al., "Real-Time Reproduction of 3D Human Images in Virtual Space Teleconferencing", Article, pp. 408-414. (AOL 074875-074881).

Fukuda, et al., "Hypermedia Personal Computer Communication System: Fujitsu Habitat", Fujitsu Sci. Tech. J. Oct. 1990, vol. 26, No. 3, pp. 197-206. (AOL 074882-074893).

Carlsson, "DIVE—a Multi-User Virtual Reality System", Article, IEEE 1993, pp. 394-400. (AOL 074894-074900).

Benford, et al., "Supporting Cooperative Work in Virtual Environments", The Computer Journal, vol. 37, No. 8, 1994, pp. 653-668. (AOL 074901-074916).

Berlage, et al., "A Framework for Shared Applications With a Replicated Architecture", Article, Nov. 3-5, 1993, pp. 249-257. (AOL 075027-075035).

Sohlenkamp, "A Virtual Office Environment Supporting Shared Applications", Article, Feb. 7-11, 1994. (AOL 075036-075044).

Handley, et al., "The Conference Control Channel Protocol (CCCP): A Scalable Base for Building Conference Control Applications", Article, 1995, pp. 275-287. (AOL 075145-075157).

Sasse, et al., "Remote Seminars through Multimedia Conferencing: Experiences from the MICE Project", Article, Proc. INET '94/JENC5, pp. 1-8. (AOL 075158-075165).

Kirstein, et al., "Piloting of Multimedia Integrated Communications for European Researchers (MICE)", Article, Proc. INET '93, pp. 1-12. (AOL 075197-075208).

Kirstein, et al., "Recent Activities in the MICE Conferencing Project", Article, Proc. INET '95. (AOL 075209-075218).

Sasse, et al., "Remote Seminars through Multimedia Conferencing: Experiences from the MICE Project", Article, Proc. INET '94/JENC5. (AOL 075249-075260).

Byte, "Network and Windows 95 Take Top BYTE Awards", Article, Jul. 1995. (AOL 055731-055732).

CompuServe, "CompuServe Producer User Guide", Article, Apr. 19, 1995, pp. 1-36. (AOL 055743-055779).

Mawby, "Designing Collaborative Writing Tools", Article, 1991, pp. 1-191. (AOL 074678-074870).

Donath, "the Illustrated Conversation", Article, 1995, pp. 79-88. (AOL 052115-052124).

Donath, "Sociable Information Spaces", Article, Jun. 20-22, 1995, pp. 269-273. (AOL 052127-052131).

Masinter, "Collaborative Information Retrieval: Gonner from MOO", Article, Proc. INET '93 (AOL 052153-052161).

Roseman, et al., "TeamRooms: Groupware for Shared Electronic Spaces", Article. (AOL 052162-052163).

Curtis, Mudding Social Phenomena in Text-Based Virtual Realities, Article, Mar. 3, 1992, pp. 1-21. (AOL 052181-052201).

(56)

References Cited

OTHER PUBLICATIONS

- Nichols, et al., "High-Latency, Low-Bandwidth Windowing in the Jupiter Collaboration System", Article, UIST '95, Nov. 14-17, 1995, pp. 111-120. (AOL 052202-052211).
- Curtis, et al., "The Jupiter Audio/Video Architecture: Secure Multimedia in Network Places", Article, 1995, pp. 1-12. (AOL 052212-052223).
- Lee, "Xsketch: A Multi-User Sketching Tool for X11", Article, 1990, pp. 169-173. (AOL 052251-052255).
- Patterson, et al., "Rendezvous: An Architecture for Synchronous Multi-User Applications", Article, Oct. 1990, pp. 317-328. (AOL 052272-052283).
- Patterson, "Comparing the Programming Demands of Single-User and Multi-User Applications", Article, UIST'91, Nov. 11-13, 1991, pp. 87-94. (AOL 052284-052291).
- Lu, et al., "Idea Management in a Shared Drawing Tool", Article, ECSCW 1991, pp. 97-112. (AOL 052292-052307).
- Lu, "Supporting Idea Management in a Shared Drawing Tool", Article, 1992, pp. 29-113. (AOL 052308-052364).
- Wexelblat, "Building Collaborative Interfaces", Article, May 1991, pp. 1-40. (AOL 052385-052405).
- Watabe, et al., "Distributed Desktop Conferencing System with Multiuser Multimedia Interface", Article, 1991 IEEE, pp. 531-539. (AOL 052406-052414).
- Watabe, et al., "Distributed Multiparty Desktop Conferencing System: MERMAID", Article, Oct. 1990, pp. 27-38. (AOL 052415-052426).
- Horn, et al., "An ISDN Multimedia Conference Bridge", Article, 1990 IEEE, pp. 853-856. (AOL 052427-052430).
- Ahuja, et al., "Coordination and Control of Multimedia Conferencing", Communications Magazine, IEEE, May 1992, vol. 30, Iss. 5, pp. 38-43. (AOL 052431-052436).
- Ensor, et al., "The Rapport Multimedia Conferencing System—A Software Overview", Article, Proc. 2nd IEEE, Mar. 1998, pp. 52-58. (AOL 052437-052443).
- Greenberg, "Personalizable Groupware: Accommodating Individual Roles and Group Differences", Article, ECSCW 1991, pp. 17-32. (AOL 052444-052459).
- Greenberg, "Sharing Views and Interactions With Single-User Applications", Article, Apr. 1990, pp. 227-237. (AOL 052460-052470).
- Sarin, et al., "Software for Interactive On-Line Conferences", Article, 1984, pp. 46-58. (AOL 052471-052484).
- Bly, et al., "Media Spaces: Bringing People Together in a Video, Audio, and Computing Environment", Article, Jan. 1993, vol. 36, No. 1, pp. 28-47. (AOL 052486-052505).
- NCSA, "The Second International WWW Conference '94 Mosaic and the Web", Jul. 14, 1994. (AOL 052506-052509).
- Frega, et al., "A Multimedia Bulletin Board in WWW Environment", Article. (AOL 052567-052574).
- Horn, et al., "An ISDN Multimedia Conference Bridge", Article, IEEE Region 10, Sep. 1990, pp. 853-856. (AOL 052575-052578).
- Tang, et al., "Montage: Providing Teleproximity for Distributed Groups", Article, Apr. 24-28, 1994, pp. 37-43. (AOL 052579-052585).
- Pearl, "System Support for Integrated Desktop Video Conferencing", Article, Dec. 1992, pp. 1-14. (AOL 052586-052600).
- Chang, et al., "Group Coordination in Participant Systems", Article, May 1990, pp. 589-599. (AOL 052601-052611).
- Ensor, et al., "User Interfaces for Multiparty Communications", Article, 1993 IEEE, pp. 1165-1171. (AOL 052612-052618).
- Tang, et al., "Supporting Distributed Groups with a Montage of Lightweight Interactions", Article, 1994, pp. 23-34. (AOL 052619-052630).
- Brinck, et al., "A Collaborative Medium for the Support of Conversational Props", Article, Nov. 1992, pp. 171-178. (AOL 052636-052643).
- Graham, et al., "Relational Views as a Model for Automatic Distributed Implementation of Multi-User Applications", Article, Nov. 1992, pp. 59-66. (AOL 052644-052651).
- Rein, et al., "riBIS: A Real-Time Group Hypertext System", Article, 1991, pp. 349-367. (AOL 052652-052670).
- Gibbs, "LIZA: An Extensible Groupware Toolkit", Article, 1989, pp. 29-35. (AOL 052671-052677).
- Clark, "Multipoint Multimedia Conferencing", Article, May 1992 IEEE, pp. 44-50. (AOL 052678-052684).
- Hill, et al., "The Rendezvous Language and Architecture", Article, Jan. 1993, vol. 36, No. 1, pp. 81-125. (AOL 052697-052702).
- Hill, et al., "The Rendezvous Architecture and Language for Constructing Multiuser Applications", ACM Transactions on Computer-Human Interaction, Jun. 1994, vol. 1, No. 2, pp. 81-125. (AOL 052703-052747).
- "Office Action," dated Mar. 18, 2008, for U.S. Appl. No. 11/510,351.
- "Amendment and Response," filed in U.S. Appl. No. 11/510,351 on Sep. 18, 2008.
- "Preliminary Amendment," for U.S. Appl. No. 11/510,351, filed Nov. 30, 2007.
- "Response to Notice of Non-Responsive reply and Supplemental Amendment and Response," for U.S. Appl. No. 11/510,351, filed Feb. 6, 2009.
- "Office Action-Non-Final Rejection" for U.S. Appl. No. 11/510,351, mailed Jul. 22, 2009, pp. 1-14.
- "Amendment and Response" for U.S. Appl. No. 11/510,351, filed Jan. 19, 2010, pp. 1-18.
- "Preliminary Amendment," for U.S. Appl. No. 11/510,463, filed Nov. 30, 2007, pp. 1-12.
- "Second Preliminary Amendment," for U.S. Appl. No. 11/510,473, filed Nov. 30, 2007, pp. 1-21.
- "Preliminary Amendment," for U.S. Appl. No. 11/836,633, filed Nov. 30, 2007, pp. 1-3.
- Office Action—Non-Final Rejection for U.S. Appl. No. 11/510,473, mailed on Oct. 5, 2009, pp. 1-49.
- Tim Meyer et al., A MOO-Based Collaboration Hypermedia System for WWW, Proceedings for Second International Conference for WWW, Oct. 1994.
- Paul Kindberg et al., Mushroom: a framework for collaboration and interaction across the Internet, In the Proceedings of ERCIM Workshop on CSCW and the Web, Feb. 1996, 11 pages.
- "Office Action-Non-Final Rejection" for U.S. Appl. No. 11/510,463, mailed on Sep. 22, 2009, pp. 1-27.
- Pavel Curtis et al., MUDS Grow Up: Social Virtual Reality in the Real World, Xerox PARC, Jan. 1993, 6 pages.
- "Amendment and Response," for U.S. Appl. No. 11/510,473, filed Feb. 5, 2010, pp. 1-26.
- "Amendment and Response," for U.S. Appl. No. 11/510,463, filed Mar. 22, 2010, pp. 1-16.
- "Corrected Amendment and Response," for U.S. Appl. No. 11/510,463, filed Apr. 1, 2010, pp. 1-16.
- "Third Preliminary Amendment," for U.S. Appl. No. 11/836,633, filed May 7, 2010, pp. 1-8.
- "Preliminary Amendment," for U.S. Appl. No. 11/836,633, filed Apr. 14, 2010, pp. 1-8.
- "Office Action-Non-Final Rejection" for U.S. Appl. No. 11/510,473, mailed May 12, 2010, pp. 1-14.
- Atul Prakash et al., DistView for Building Efficient Collaborative Applications using Replicated Objects, Proceedings of the 1994 ACM conference on Computer supported cooperative work, pp. 153-164.
- Bentley et al., Supporting collaborative information sharing with the World Wide Web: The BSCW shared workspace system, Proceedings of the 4th International World Wide Web Conference, Dec. 1995, 12 pages.
- K.J. Maly et al., Mosaic + XTV = CoReview, Computer Networks and ISDN Systems, vol. 27 Issue 6, Apr. 1995, pp. 849-860, Proceedings of the Thrid International World Wide Web Conference.
- "Preliminary Amendment" filed on Nov. 30, 2007, in U.S. Appl. No. 11/510,351, filed Aug. 24, 2006, by inventor Daniel L. Marks.
- "Response to Notice of Non-Responsive reply and Supplemental Amendment and Response" filed on Feb. 6, 2009, in U.S. Appl. No. 11/510,351, filed Aug. 24, 2006, by inventor Daniel L. Marks.
- "Office Action" mailed on Jul. 22, 2009, in U.S. Appl. No. 11/510,351, filed Aug. 24, 2006, by inventor Daniel L. Marks.

(56)

References Cited

OTHER PUBLICATIONS

- “Amendment and Response” filed on Jan. 19, 2010, in U.S. Appl. No. 11/510,351, filed Aug. 24, 2006, by inventor Daniel L. Marks.
- “Office Action” mailed on Mar. 18, 2008, in U.S. Appl. No. 11/510,351, filed Aug. 24, 2006, by inventor Daniel L. Marks.
- “Amendment and Response” filed on Sep. 18, 2008, in U.S. Appl. No. 11/510,351, filed Aug. 24, 2006, by inventor Daniel L. Marks.
- “Amendment and Response” filed on Feb. 5, 2010, for U.S. Appl. No. 11/510,473, filed Aug. 24, 2006, by inventor Daniel L. Marks.
- “Preliminary Amendment” filed on Nov. 30, 2007, for U.S. Appl. No. 11/510,473, filed Aug. 24, 2006, by inventor Daniel L. Marks.
- “Office Action” mailed on Oct. 5, 2009, for U.S. Appl. No. 11/510,473, filed Aug. 24, 2006, by inventor Daniel L. Marks.
- “Office Action-Final Rejection” mailed on May 12, 2010, for U.S. Appl. No. 11/510,473, filed Aug. 24, 2006, by inventor Daniel L. Marks.
- “Amendment After Final” filed on Jun. 11, 2010, for U.S. Appl. No. 11/510,473, filed Aug. 24, 2006, by inventor Daniel L. Marks.
- “Preliminary Amendment” filed on Nov. 30, 2007, in U.S. Appl. No. 11/510,463, filed Aug. 24, 2006, by inventor Daniel L. Marks.
- “Office Action” mailed on Sep. 22, 2009, in U.S. Appl. No. 11/510,463, filed Aug. 24, 2006, by inventor Daniel L. Marks.
- “Corrected Amendment and Response” filed on Apr. 1, 2010, in U.S. Appl. No. 11/510,463, filed Aug. 24, 2006, by inventor Daniel L. Marks.
- “Amendment and Response” filed on Mar. 22, 2010, in U.S. Appl. No. 11/510,463, filed Aug. 24, 2006, by inventor Daniel L. Marks.
- “Office Action-Final Rejection” mailed on Jun. 28, 2010, for U.S. Appl. No. 11/510,463, filed Aug. 24, 2006, by inventor Daniel L. Marks.
- “Preliminary Amendment” filed on Nov. 30, 2007, for U.S. Appl. No. 11/836,633, filed Aug. 9, 2007, by inventor Daniel L. Marks.
- “Preliminary Amendment” filed on Apr. 14, 2010, for U.S. Appl. No. 11/836,633, filed Aug. 9, 2007, by inventor Daniel L. Marks.
- “Third Preliminary Amendment” filed on May 7, 2010, for U.S. Appl. No. 11/836,633, filed Aug. 9, 2007, by inventor Daniel L. Marks.
- “Fourth Preliminary Amendment” filed on May 25, 2010, for U.S. Appl. No. 11/836,633, filed Aug. 9, 2007, by inventor Daniel L. Marks.
- “Amendment and Response” filed on Jul. 23, 2010, in U.S. Appl. No. 11/510,463, filed Aug. 24, 2006, by inventor Daniel L. Marks.
- Kankanahalli Srinivas et al., MONET: A Multi-media System for Conferencing and Application Sharing in Distributed Systems, Feb. 1992, CERC Technical Report Series Research Note, 19 pages.
- Vinod Anupam and Chandrajit L. Bajai. Shastra: Multimedia Collaborative Design Environment. IEEE Multimedia. Summer; 1994. pp. 39-49. Purdue University.
- Vinod Anupam and Chandrajit L. Bajai. Collaborative Multimedia Scientific Design in SHASTRA. pp. 1-12. Department of Computer Sciences, Purdue University, West Lafayette, Indiana.
- Peter K. Trzyna, “Supplemental Amendment and Response” filed on Nov. 5, 2010, in U.S. Appl. No. 11/510,351, filed Aug. 24, 2006. pp. 1-18. USA.
- Patrice L. Winder, “Office Action” mailed on Nov. 24, 2010, in U.S. Appl. No. 11/510,463, filed Aug. 24, 2006. pp. 1-25. USA.
- Peter K. Trzyna, “Amendment and Response” filed on Jul. 23, 2010, in U.S. Appl. No. 11/510,463, filed Aug. 24, 2006. pp. 1-15. USA.
- “ITU-T: Telecommunication Standardization of Sector ITU: Series T: Terminal Equipments and Protocols for Telematic Services,” International Telecommunication Union, T.120, (Jul. 1996) pp. 1-24.
- “T.120 Whitepaper: A Primer on the T.120 Series Standard,” DataBeam Corporation, 1995, pp. 1-15.
- “Complaint: Brian Hollander vs. Peter K. Trzyna and PTK Technologies, LLC,” Filed Nov. 13, 2007, pp. 1-18.
- Krishnamurthy, et al., “Yeast: A General Purpose Event-Action System,” IEEE Transactions on Software Engineering, vol. 21, No. 19, Oct. 1995. (AOL 052778-052790).
- Lovestrand, et al., “Being Selectively Aware with the Khronika System,” Proceedings of the Second European Conference on Computer-Supported Cooperative Work, Sep. 25-27, 1991, Amsterdam, The Netherlands, pp. 265-277. (AOL 052791-052803).
- Dourish, et al., “Portholes: Supporting Awareness in a Distributed Work Group,” Chi '92, May 3-7, 1992, pp. 541-547. (AOL 052804-052810).
- Gaver, et al., “Realizing a Video Environment: Europarc’s Rave System,” Chi '92, May 3-7, 1992, pp. 27-35. (AOL 052811-052819).

* cited by examiner

FIG. 1

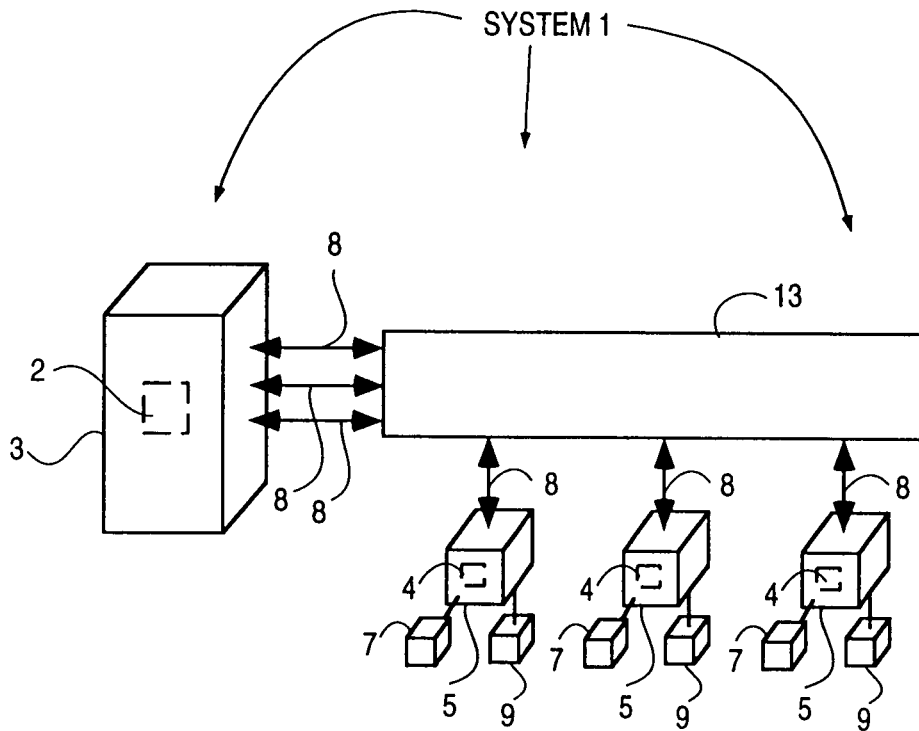

FIG. 2

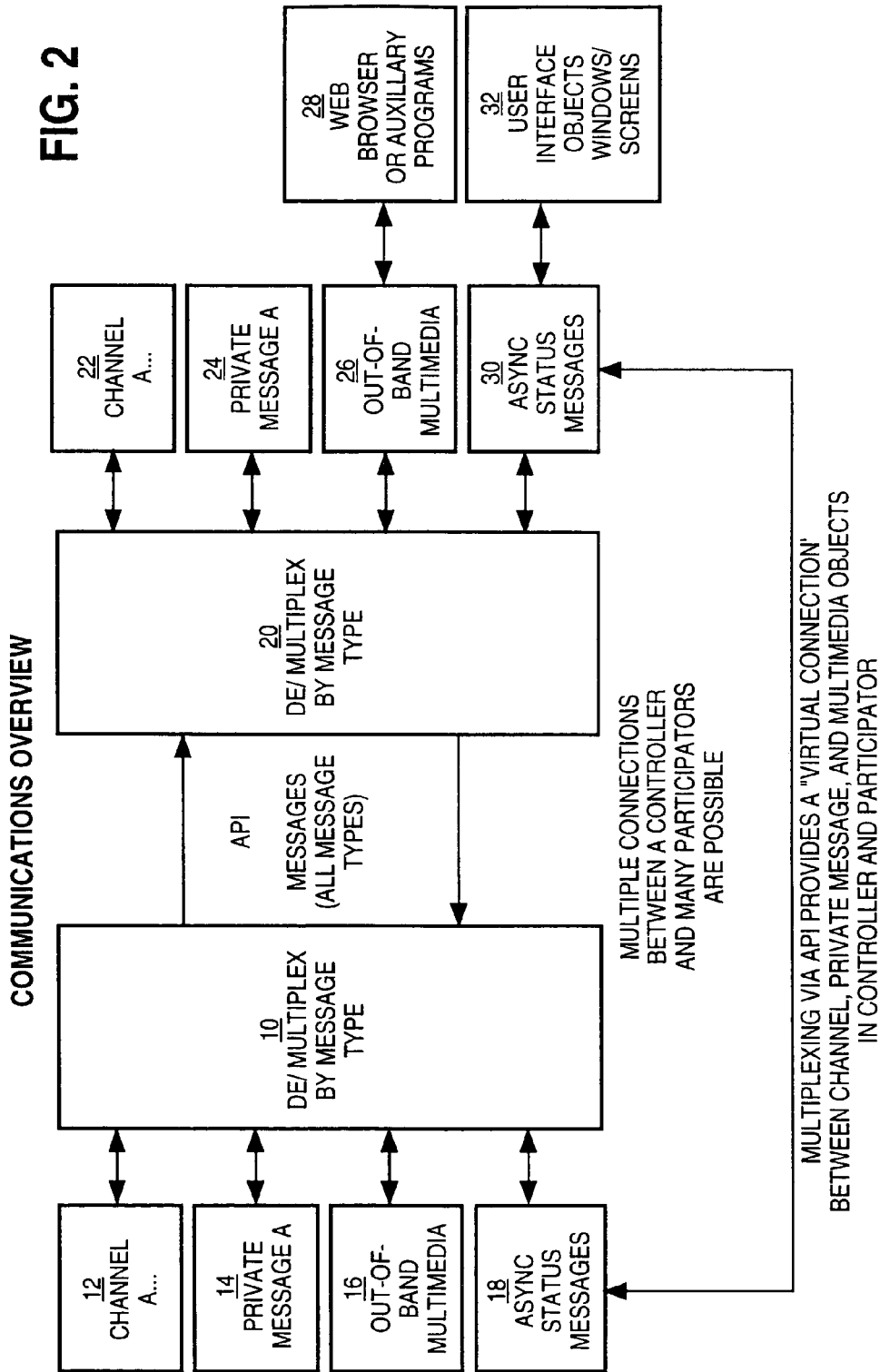

FIG. 3

DATA AND COMMUNICATIONS
DEPENDENCY DIAGRAM CONTROLLER
GROUP CHANNEL STRUCTURE

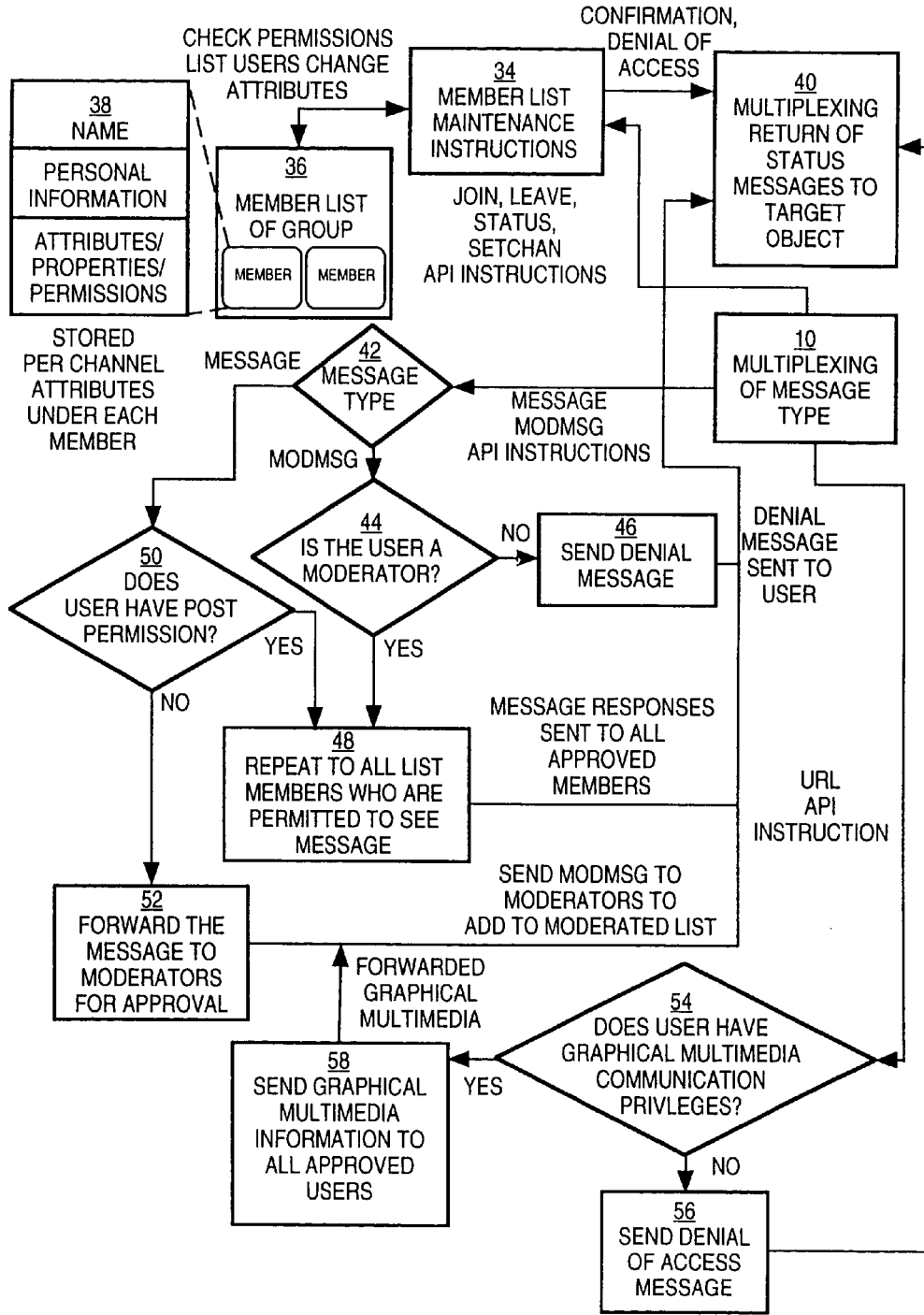

FIG. 4

CENTRAL CONTROLLER LOOP COMMUNICATIONS

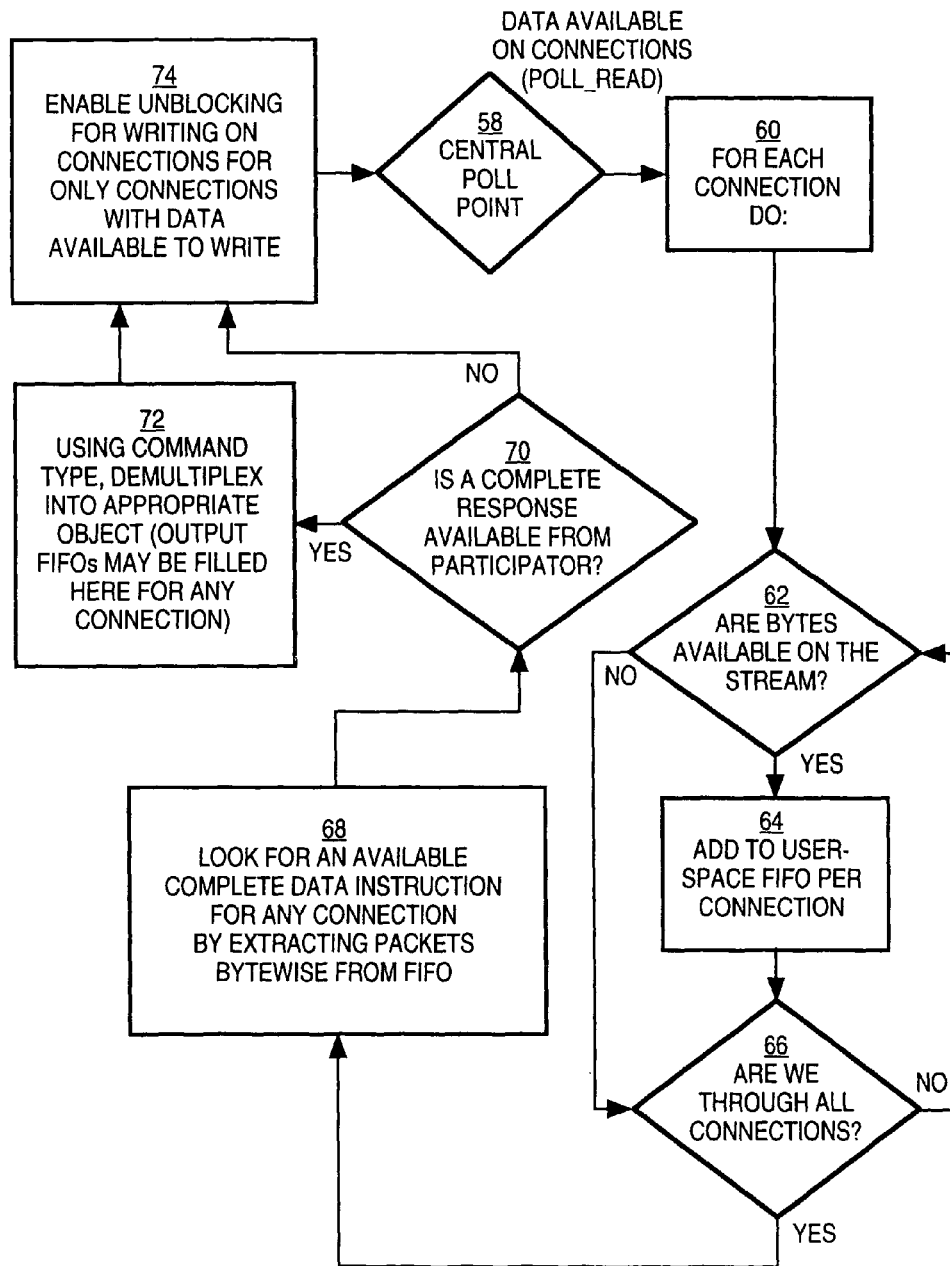

FIG. 5

CLIENT CHANNEL DATA STRUCTURE AND INFORMATION FLOW DIAGRAM

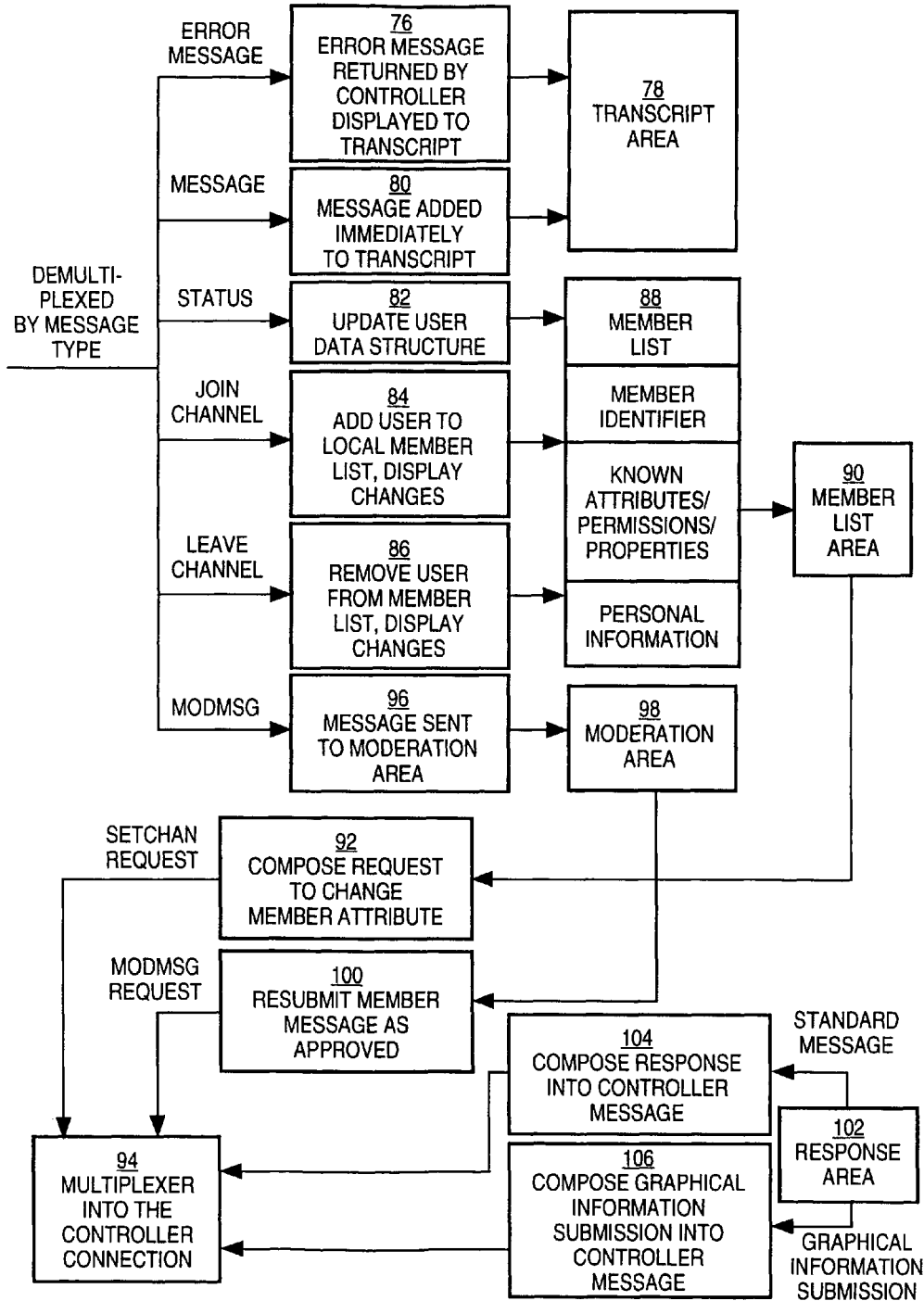

FIG. 6

PARTICIPATION SOFTWARE OUT-OF-BAND MULTIMEDIA
OUT-OF-BAND MULTIMEDIA INFORMATION FLOW DIAGRAM

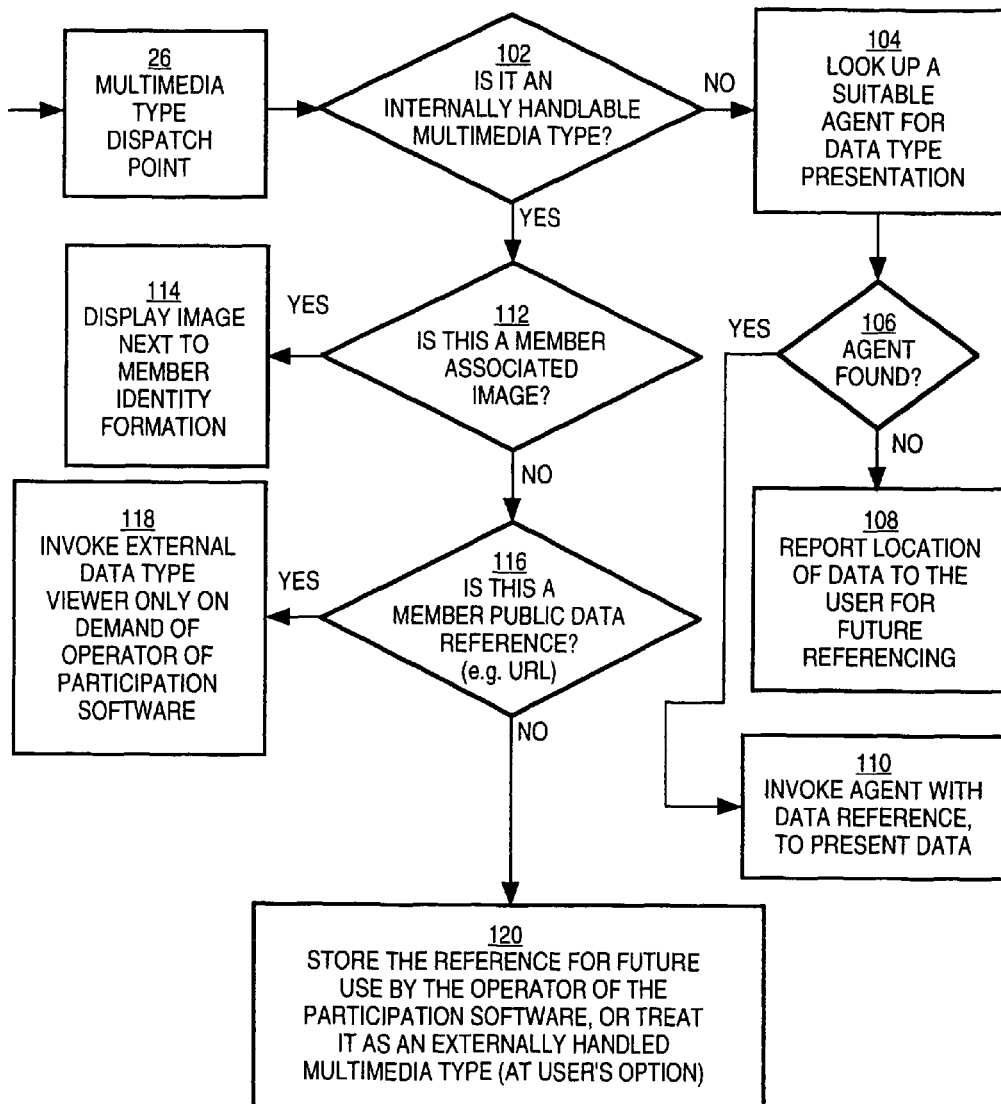

FIG. 7

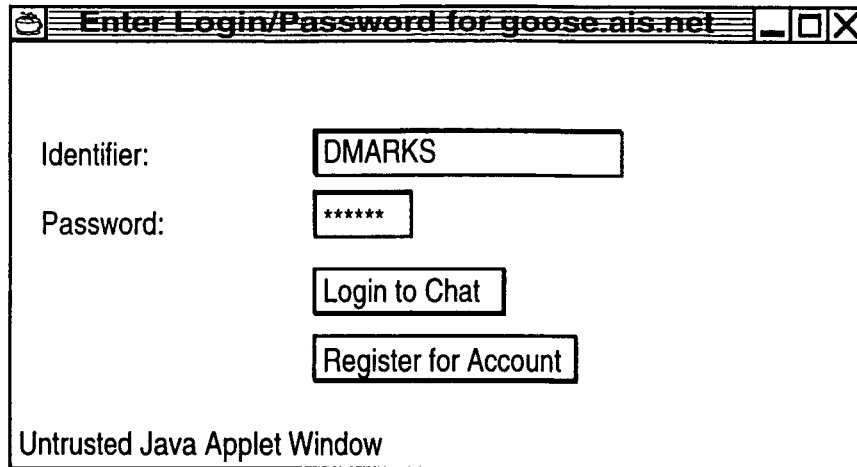

FIG. 8

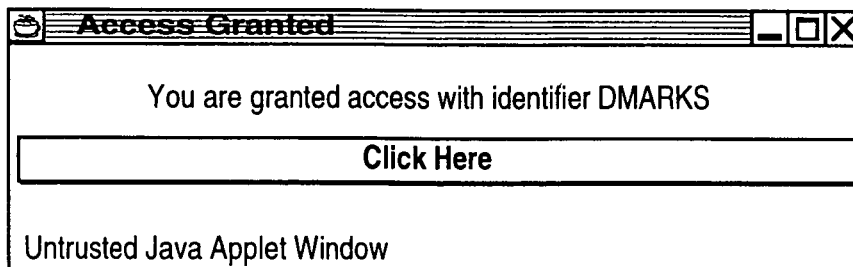

FIG. 9

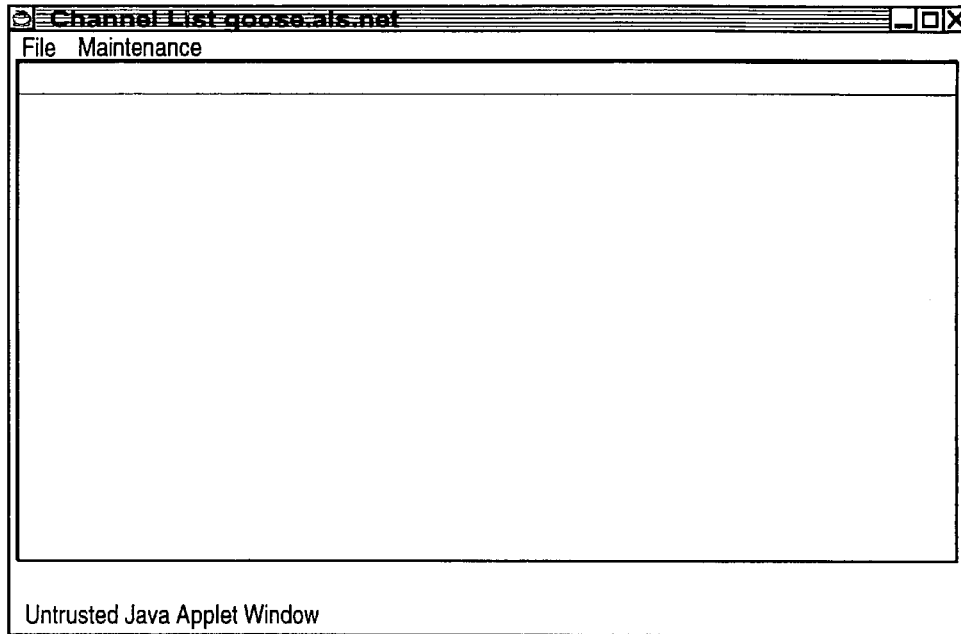

FIG. 10

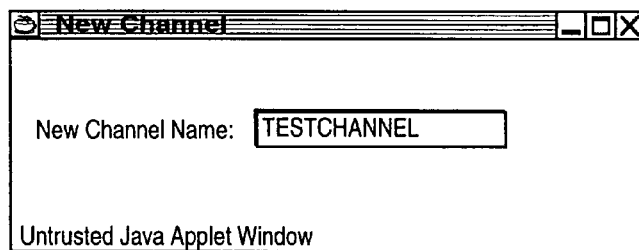

FIG. 11

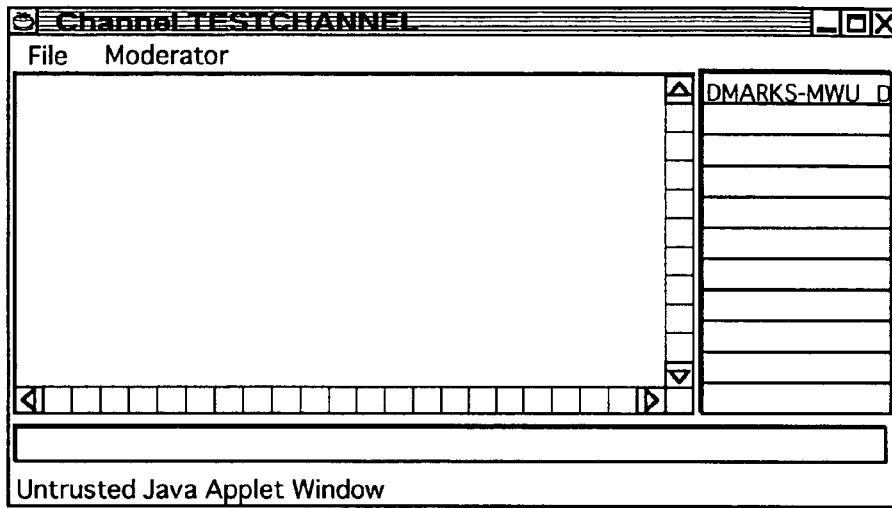

FIG. 12

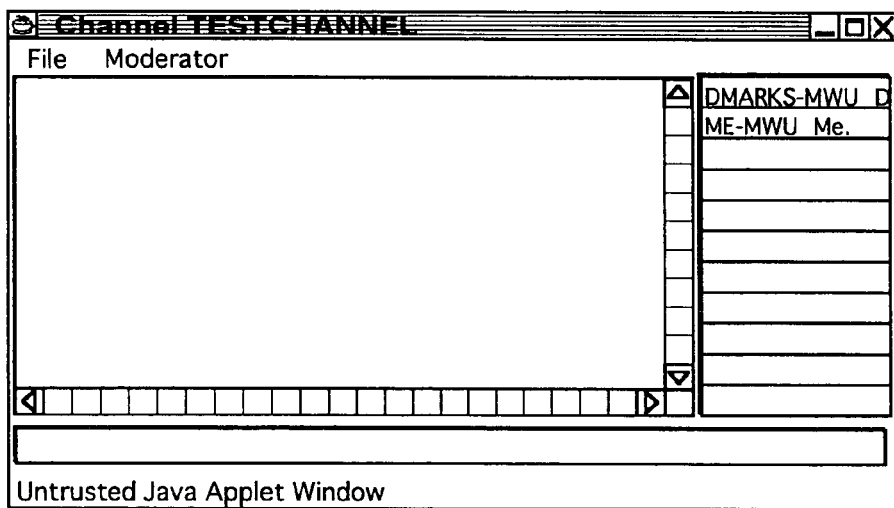

FIG. 13

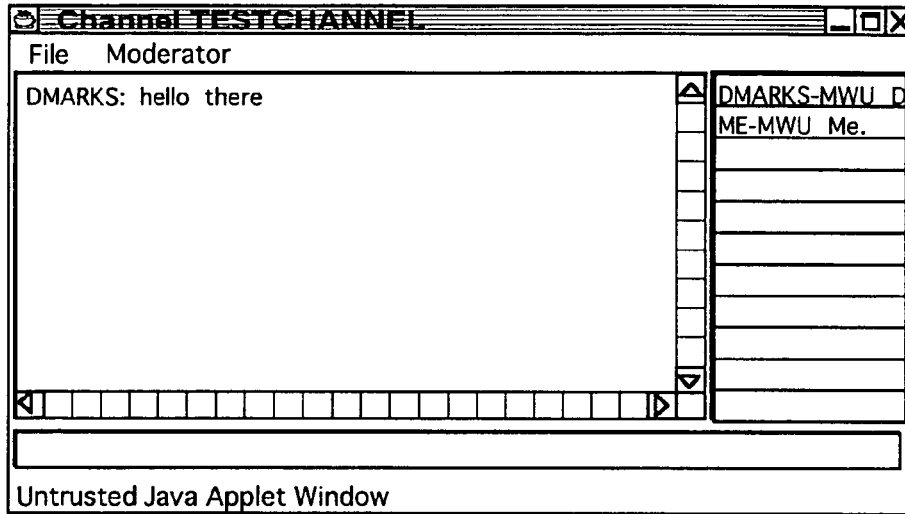

FIG. 14

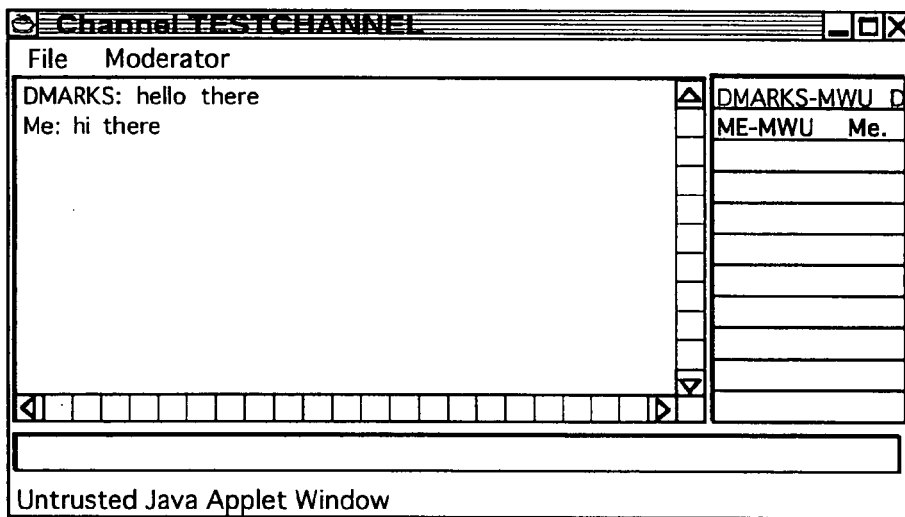

FIG. 15

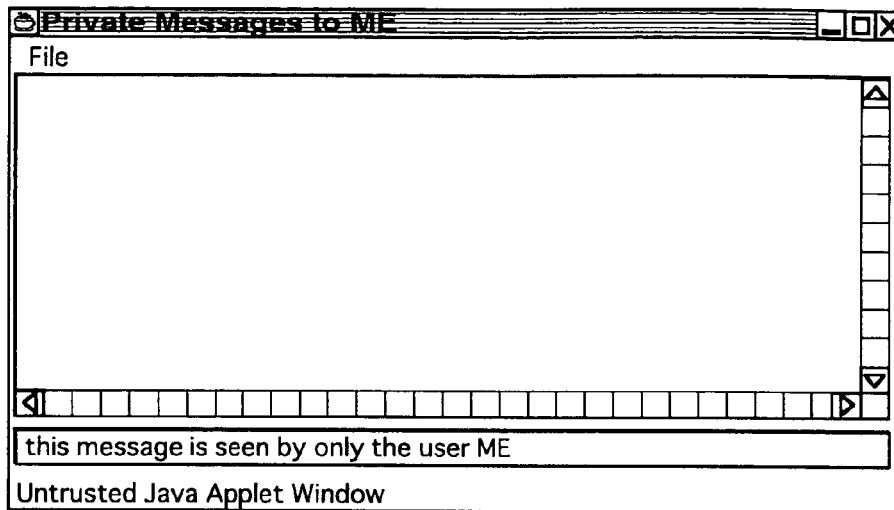

FIG. 16

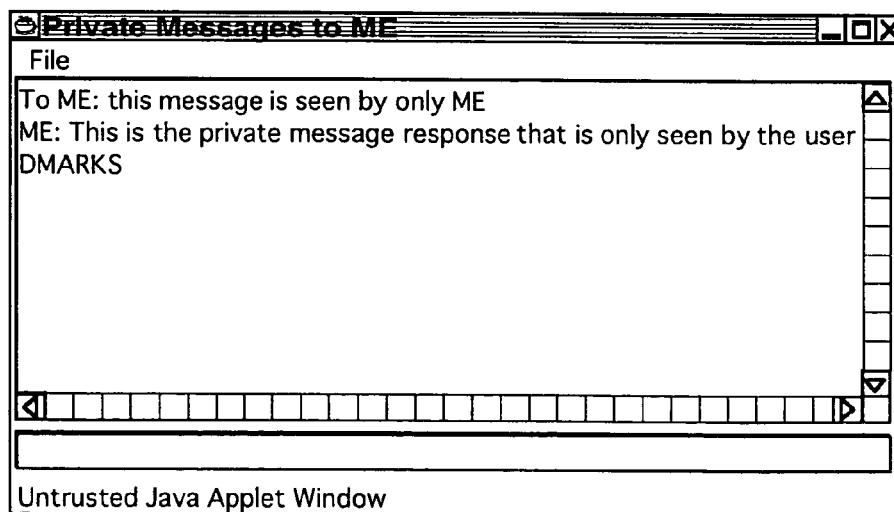

FIG. 17

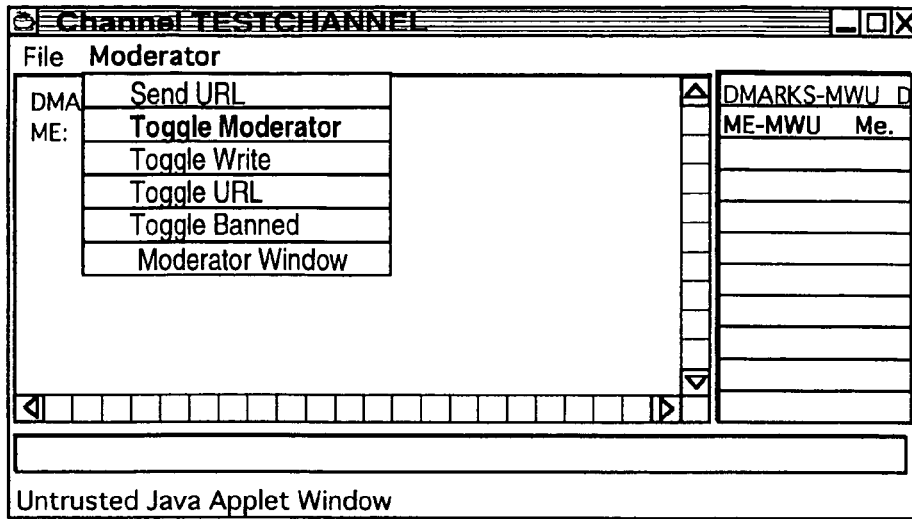

FIG. 18

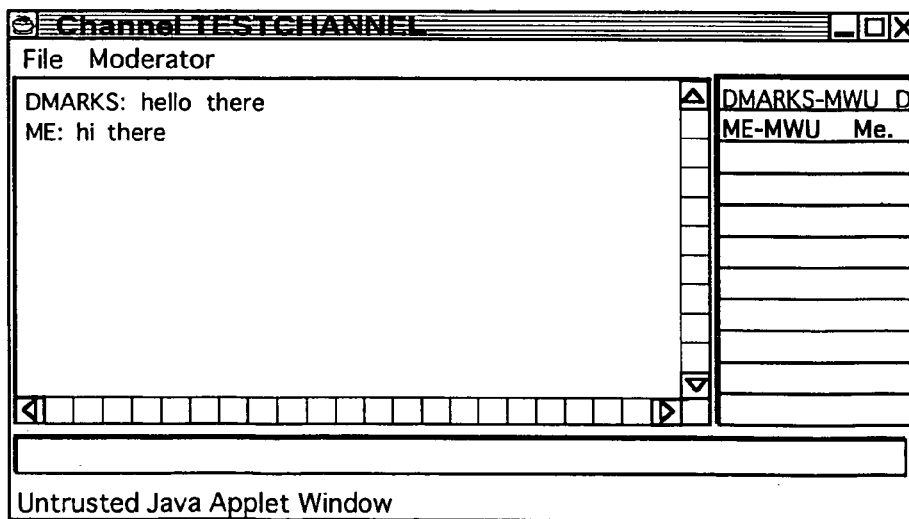

FIG. 19

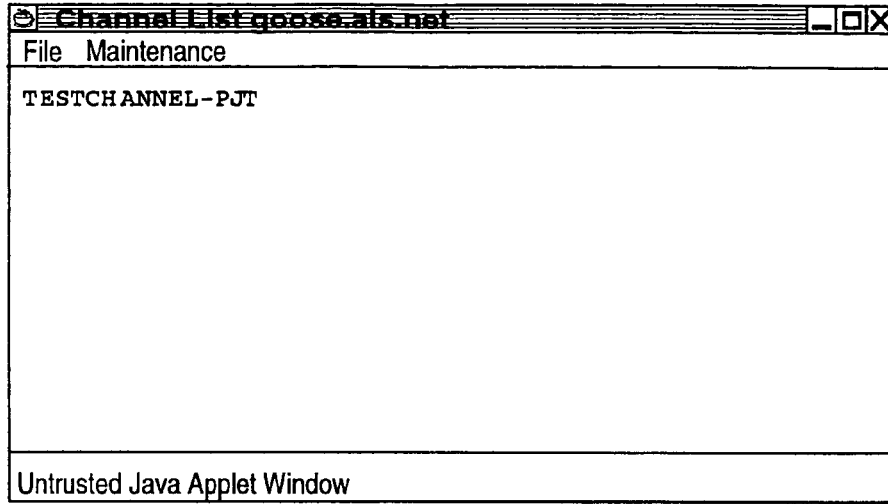

FIG. 20

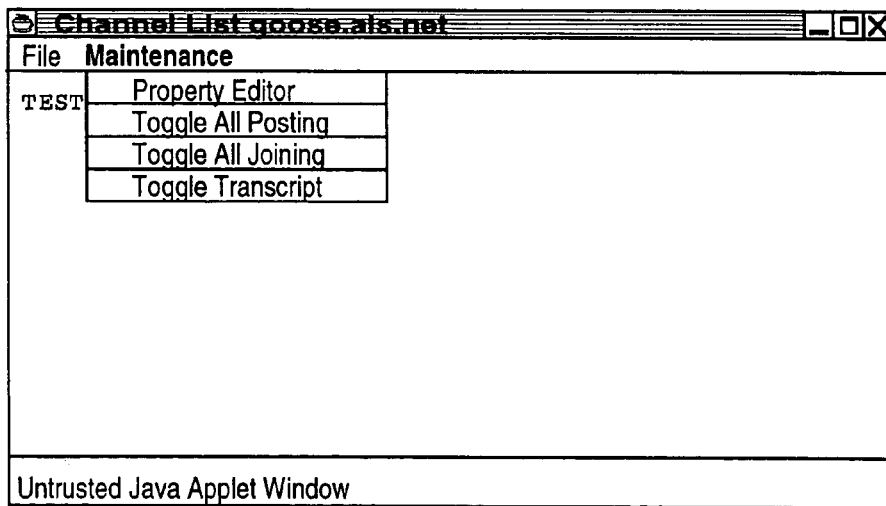

FIG. 21

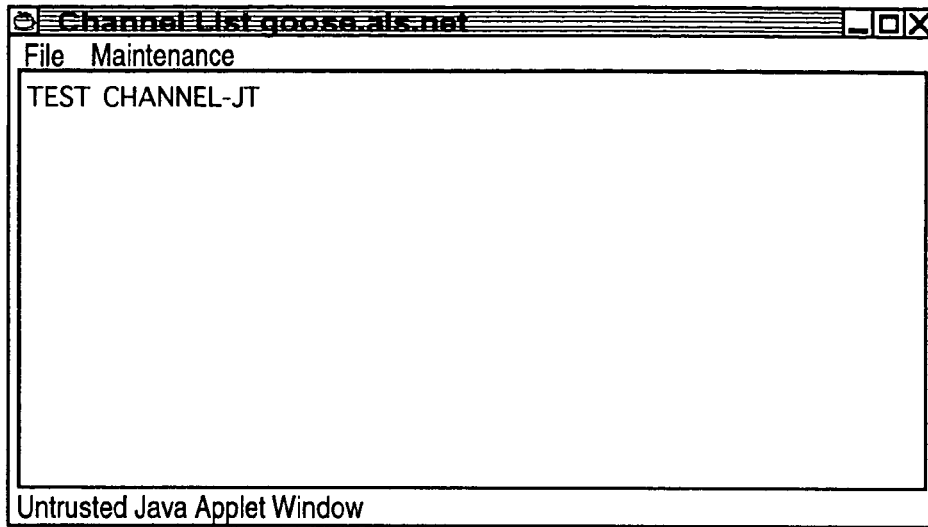

FIG. 22

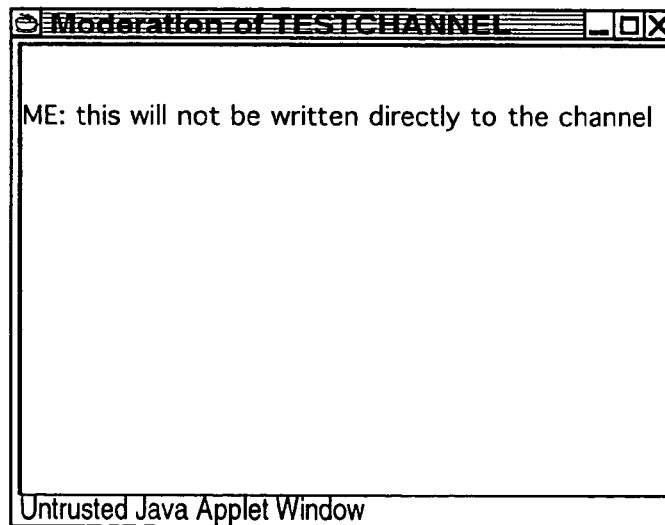

FIG. 23

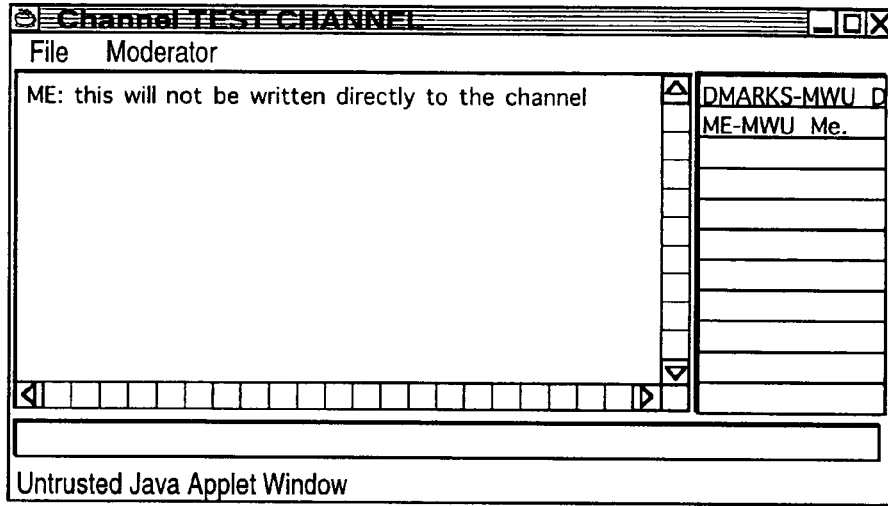

FIG. 24

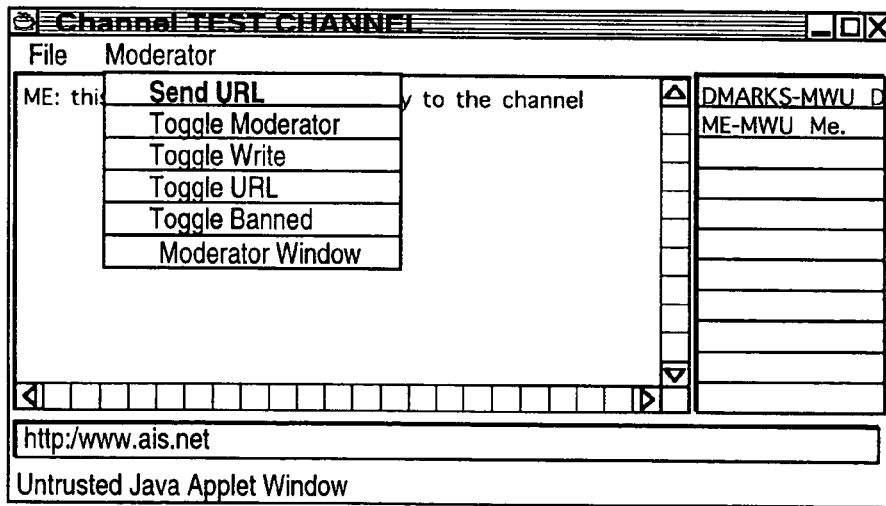

FIG. 25

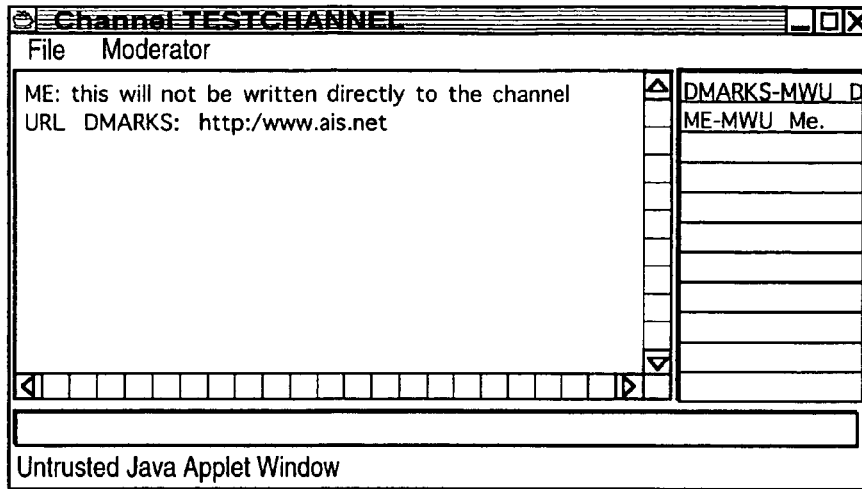

FIG. 26

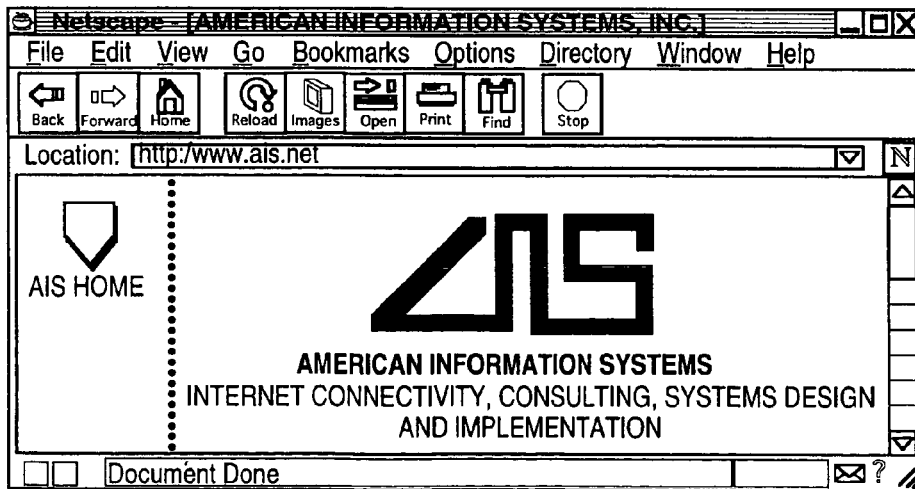

FIG. 27

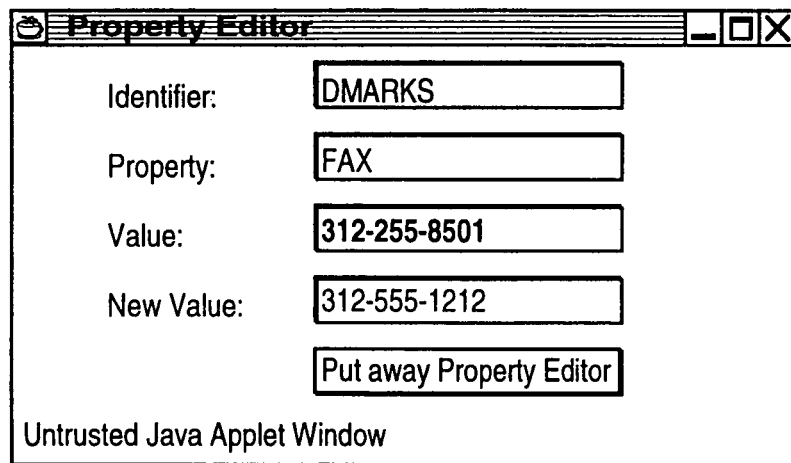

FIG. 28

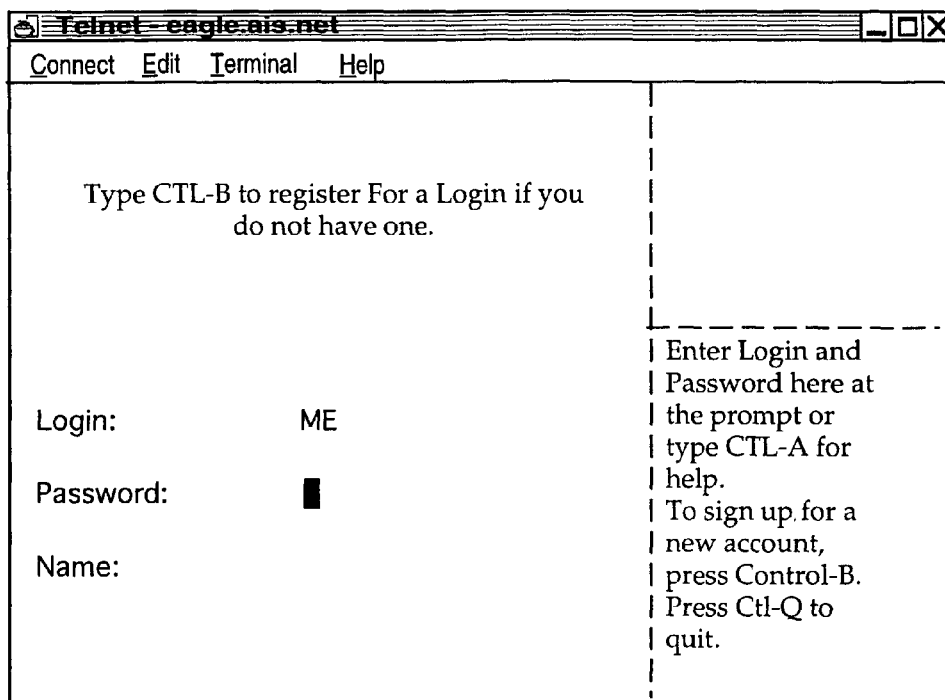

FIG. 29

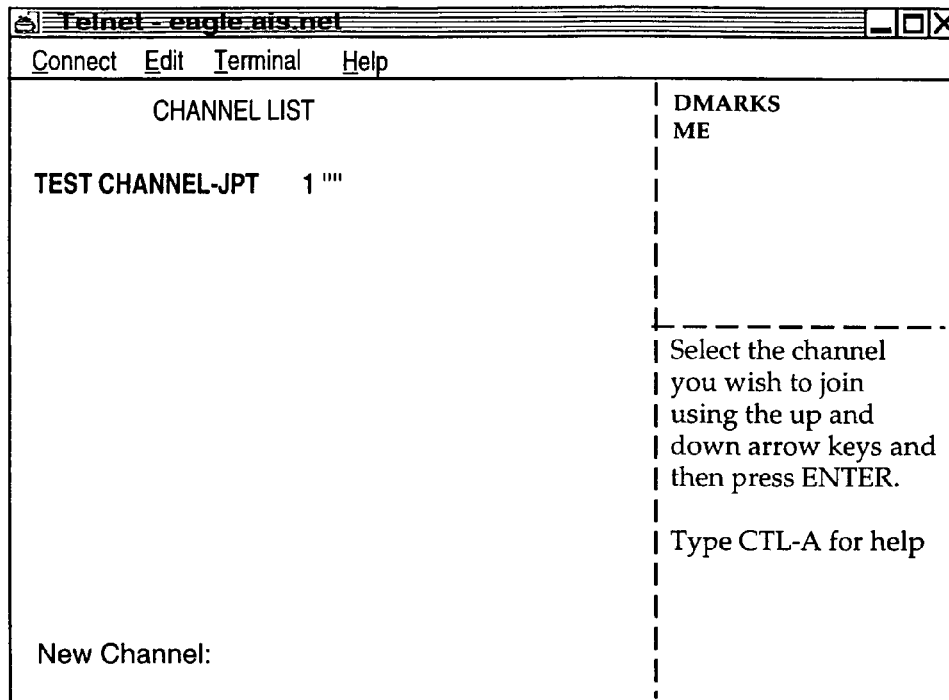

FIG. 30

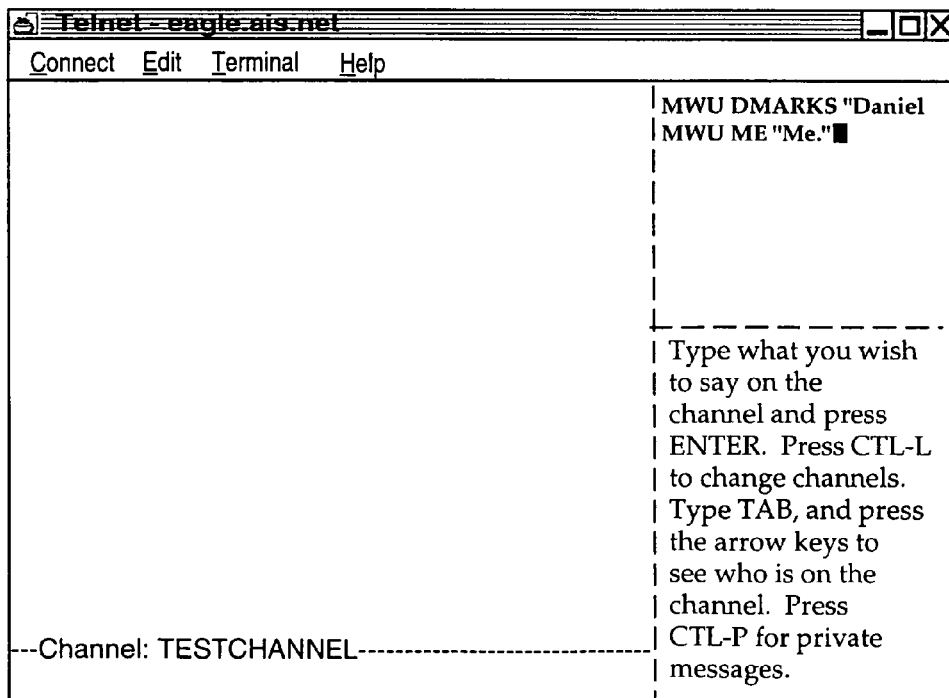

FIG. 31

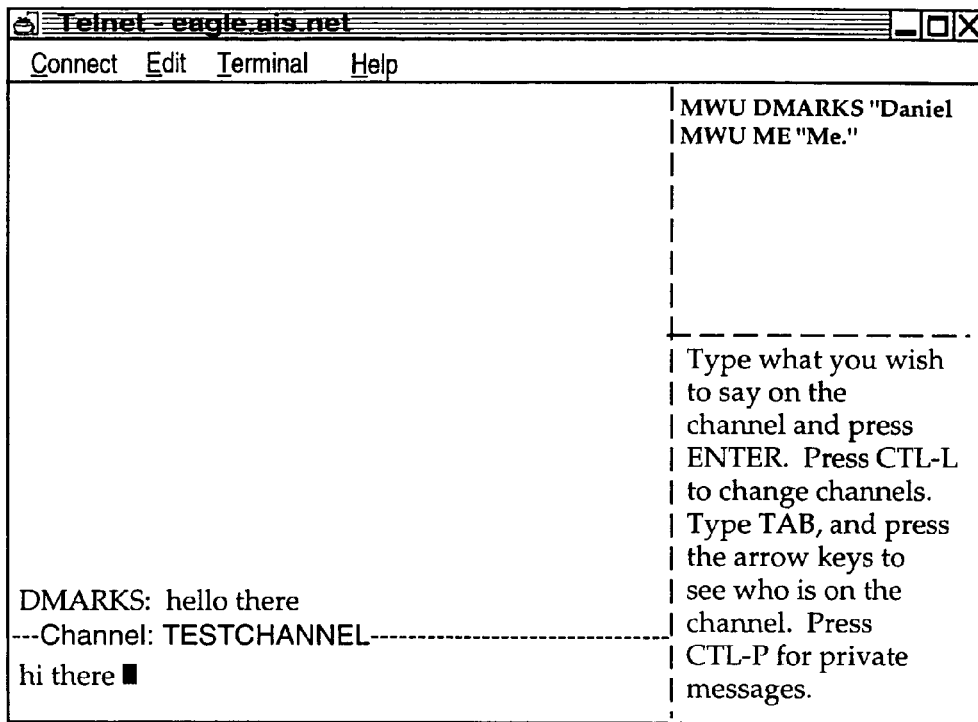

FIG. 32

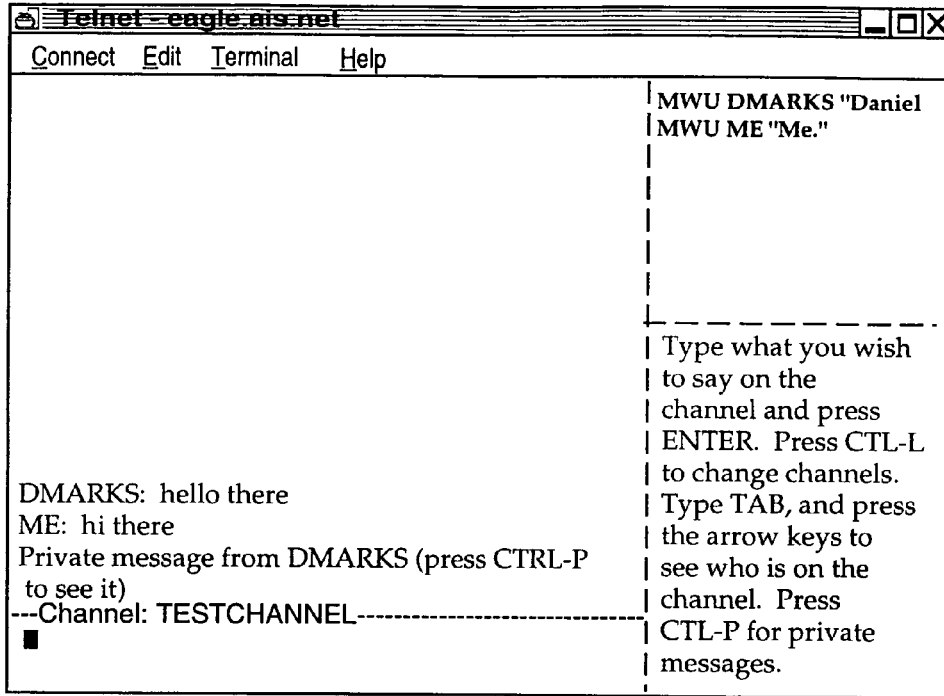

FIG. 33

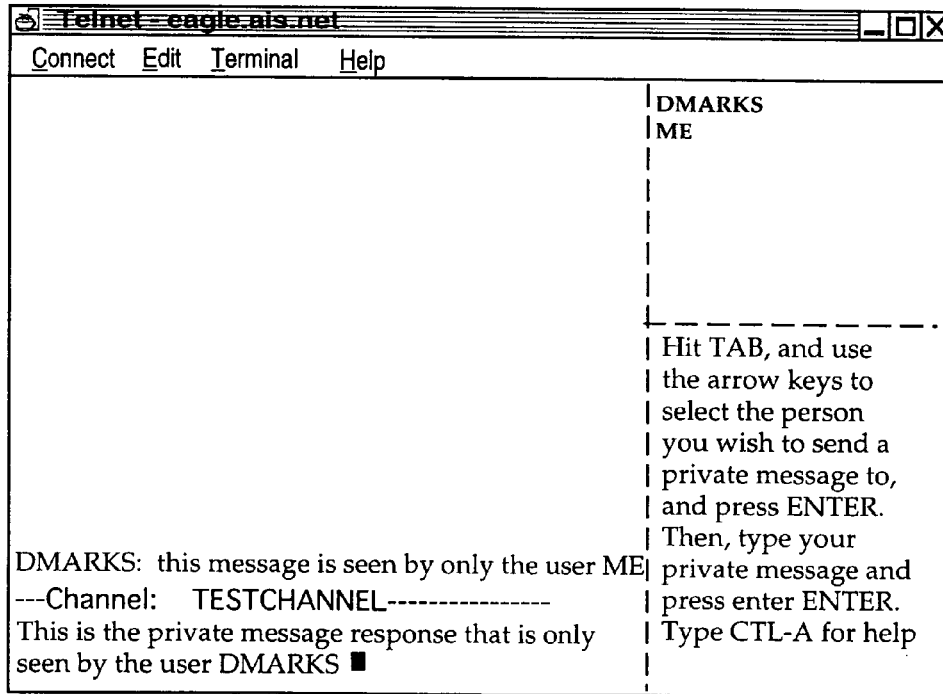
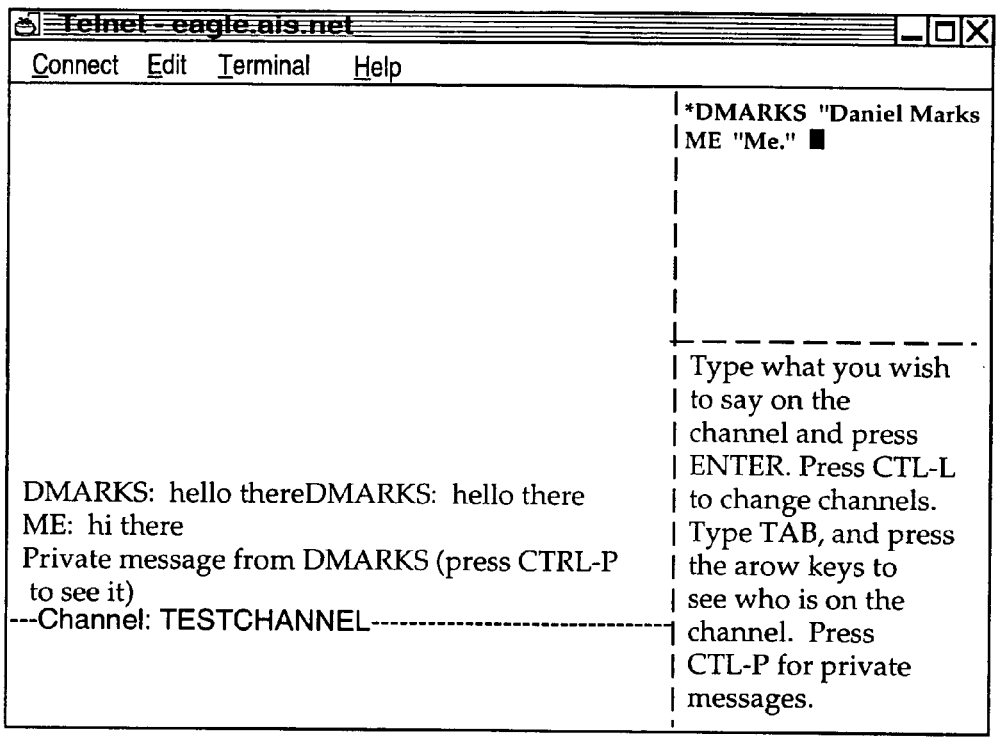

FIG. 34



REAL TIME COMMUNICATIONS SYSTEM

This invention is a continuation of Ser. No. 08/617,658 filed Apr. 1, 1996, and issued as U.S. Pat. No. 5,956,491 on Sep. 21, 1999, directed to an apparatus, a manufacture, and methods for making and using the same, in a field of digital electrical computer systems.

I. FIELD OF INVENTION

More particularly, the present invention is directed to a digital electrical computer system involving a plurality of participator computers linked by a network to at least one of a plurality of participator computers, the participator computers operating in conjunction with the controller computer to handle multiplexing operations for communications involving groups of some of the participator computers.

II. BACKGROUND OF THE INVENTION

Multiplexing group communications among computers ranges from very simple to very complex communications systems. At a simple level, group communications among computers involve electronic mail sent in a one way transmission to all those in a group or subgroup using, say, a local area network. Arbitrating which computers receive electronic mail is a rather well understood undertaking.

On a more complex level, corporations may link remote offices to have a conference by computer. A central computer can control the multiplexing of what appears as an electronic equivalent to a discussion involving many individuals.

Even more complex is linking computers to communicate in what has become known as a "chat room." Chat room communications can be text, as exemplified by such Internet service providers as America On Line. Multiplexing multimedia is more complex for this electronic environment.

The Internet was structured for one-way communications analogous to electronic mail, rather than for real time group chat room communications. Further, unlike the an Internet service provider, which has control over both the hardware platform and the computer program running on the platform to create the "chat room", there is no particular control over the platform that would be encountered on the Internet. Therefore, development of multiplexing technology for such an environment has been minimal.

Even with an emergence of the World Wide Web, which does have certain graphical multimedia capability, sophisticated chat room communication multiplexing has been the domain of the Internet service providers. Users therefore have a choice between the limited audience of a particular Internet Service provider or the limited chat capability of the Internet.

III. SUMMARY OF THE INVENTION

It is an object of the present invention to overcome such limitations of the prior art and to advance and improve the technology of group computer multiplexing to enable better computerized group communications.

It is another object of the present invention to provide a computerized human communication arbitrating and distributing system.

It is yet another object of the present invention to provide a group communication multiplexing system involving a controller digital computer linked to a plurality of participator computers to organize communications by groups of the participator computers.

It is still another object of the present invention to link the controller computer and the plurality of computers with respective software coordinated to arbitrate multiplexing activities.

It is still a further object of the present invention to provide a chat capability suitable for handling graphical, textual, and multimedia information in a platform independent manner.

These and other objects and utilities of the invention, apparent from the discussion herein, are addressed by a computerized human communication arbitrating and distributing system. The system includes a controller digital electrical computer and a plurality of participator digital computers, each of the participator computers including an input device for receiving human-input information and an output device for presenting information to a user having a user identity. A connection such as the Internet links the controller computer with each of the participator computers.

Controller software runs on the controller computer, programming the controller computer to arbitrate in accordance with predefined rules including said user identity, which ones of the participator computers can interact in one of a plurality of groups communicating through the controller computer and to distribute real time data to the respective ones of the groups.

Participator software runs on each of the participator computers to program each of the participator computers to operate a user interface. The user interface permits one of the users to send and/or receive a multimedia information message to the controller computer, which arbitrates which of the participator computers receives the multimedia information message. The controller computer also conveys the multimedia information message to the selected participator computers to present the multimedia information to the respective user.

Therefore, for a computer system involving a plurality of programmed participator computers running the participator computer program can interact through a programmed controller computer with the controller computer multiplexing the communications for groups formed from the plurality, as well as arbitrating communications behavior.

IV. BRIEF DESCRIPTION OF THE DRAWINGS

FIG. 1 is a depiction of hardware suitable for performing the present invention;

FIG. 2 is a communications overview of the present invention.

FIG. 3 is a data and communications dependency diagram for the controller group channel structure of the present invention.

FIG. 4 is a flow chart of the central controller loop communications for the controller computer.

FIG. 5 is a client channel data structure and information flow diagram of the present invention.

FIG. 6 is a participator software out-of-band multimedia information flow diagram of the present invention.

FIG. 7 is an illustration of a login/password screen of the present invention.

FIG. 8 is an illustration of a confirmation screen of the present invention.

FIG. 9 is an illustration of a channel list area screen of the present invention.

FIG. 10 is an illustration of a New Channel option pull-down menu screen of the present invention.

FIG. 11 is an illustration of a member on a new channel screen of the present invention.

FIG. 12 is an illustration of a second member on the new channel screen of the present invention.

FIG. 13 is an illustration of a communication on the new channel screen of the present invention.

FIG. 14 is an illustration of a private message window on the new channel screen of the present invention.

FIG. 15 is an illustration of a private message displayed on the private message window on the new channel screen of the present invention.

FIG. 16 is a further illustration of the private message on the private message window on new channel screen of the present invention.

FIG. 17 is an illustration of an attribute revocation on the new channel screen of the present invention.

FIG. 18 is a further illustration of the new channel screen of the present invention.

FIG. 19 is an illustration of the channel list window screen of the present invention.

FIG. 20 is an illustration of the toggle posting option on a screen of the present invention.

FIG. 21 is an illustration of a moderated version of the new channel screen of the present invention.

FIG. 22 is an illustration of a communication on a moderation window screen of the present invention.

FIG. 23 is an illustration of the communication passed on to the moderated version of the new channel screen of the present invention.

FIG. 24 is an illustration of a communication, for sending a graphical multimedia message, on to the moderated version of the new channel screen of the present invention.

FIG. 25 is an illustration, showing the name of the URL, on a moderated version of the new channel screen of the present invention.

FIG. 26 is an illustration of data associated with the graphical multimedia message on a moderated version of the new channel screen of the present invention.

FIG. 27 is an illustration of a proprietary editor, suitable for a dialog to change tokens, on a screen of the present invention.

FIG. 28 is an illustration of a text based interface login/password screen of the present invention.

FIG. 29 is an illustration of a text-based interface group screen of the present invention.

FIG. 30 is another illustration of a text-based interface group screen of the present invention.

FIG. 31 is another illustration of a text-based interface group screen of the present invention.

FIG. 32 is an illustration of a text-based interface private message screen of the present invention.

FIG. 33 is another illustration of a text-based interface private message screen of the present invention.

FIG. 34 is another illustration of a text-based interface group with moderator screen of the present invention.

V. DETAILED DESCRIPTION OF THE DRAWINGS

In providing a detailed description of a preferred embodiment of the present invention, reference is made to an appendix hereto, including the following items.

Appendix Contents
 ALLUSER C
 ALLUSER H
 CHANNEL C
 CHANNEL H
 CHANNEL HLP
 CLIST C
 CLIST H
 CLIST HLP
 EDITUSER C

EDITUSER H
 ENTRYFRM C
 ENTRYFRM H
 ENTRYFRM HLP
 HELP C
 HELP H
 HELPSCR C
 HELPSCR H
 LINEEDIT C
 LINEEDIT H
 LIST C
 LIST H
 LOGIN HLP
 MAIN C
 MAKEFILE
 MESSAGE C
 MESSAGE H
 MODERAT HLP
 PRIVATE C
 PRIVATE H
 PRIVATE HLP
 SOCKIO C
 SOCKIO H
 STR C
 STR H
 UCCLIENT
 USER C
 USER H
 WINDOW C
 WINDOW H

While platform controlled embodiments are within the scope of the invention, it is particularly advantageous to have a platform independent embodiment, i.e., an embodiment that is byte code compiled.

Referring now to FIG. 1, the overall functioning of a computerized human communication arbitrating and distributing System 1 of the present invention is shown with odd numbers designating hardware or programmed hardware, and even numbers designating computer program logic and data flow. The System 1 includes a digital Controller Computer 3, such as an Internet service provider-type computer. The Controller Computer 3 is operating with an operating system.

System 1 also includes a plurality of digital Participator Computers 5, each of which may be an IBM-compatible personal computer with a processor and a DOS operating system. Each of the Participator Computers 5 includes an Input Device 7 for receiving human-input information from a respective human user. The Input Device 7 can be, for example, a keyboard, mouse or the like. Each of the Participator Computers 5 also includes an Output Device 9 for presenting information to the respective user. The Output Device 9 can be a monitor, printer (such as a dot-matrix or laser printer), or preferably both are used. Each of the Participator Computers 5 also includes a Memory 11, such as a disk storage means.

The System 1 includes a Connection 13 located between, so as to link, the Controller Computer 3 with each of the Participator Computers 5. The Connection 13 can be an Internet or more particularly, a World Wide Web connection.

The Controller Computer 3 is running and under the control of Controller Software 2, which directs the Controller Computer 3 to arbitrate in accordance with predefined rules including a user identity, which ones of the Participator Computers 5 can interact in one of a plurality of groups through the Controller Computer 3 and to distribute real time data to the respective ones of the groups.

5

The Participator Computers **5** are each running and under the control of Participator Software **4**, which directs each of the Participator Computers **5** to handle a user Interface permitting one said user to send a multimedia information Message **8** to the Controller Computer **3**, which arbitrates which of the Participator Computers **5** receives the multimedia information Message **8** and which conveys the multimedia information Message **8** to the selected participator computers **5** to present the multimedia information Message **8** to the respective user.

The present invention comprehends communicating all electrically communicable multimedia information as Message **8**, by such means as pointers, for example, URLs. URLs can point to pre-stored audio and video communications, which the Controller Computer **3** can fetch and communicate to the Participator Computers **5**.

Turning now to FIG. **2**, there is shown a communications overview of the present invention. Beginning with the Controller Computer Software **2**, reference is made to Block **10**, which illustrates demultiplexing and multiplexing operations carried out by message type on API messages of all types. Block **10** links to Block **12**, which is illustrative of channel A . . . Block **10** also links to Block **14**, which illustrates handling private message A. Block **10** also links to Block **16**, illustrative of handling out-of-band media. Block **10** additionally links to Block **18**, which illustrates asynchronous status messages.

Multiple connections between the controller computer **3** and a plurality of participator computers **5** permit communication implemented via the interplay of controller software **2** and participator software **4**. With particular regard to the participator software **4** illustrated in FIG. **2**, Block **20** is illustrative of demultiplexing and multiplexing operations carried out by message type on API messages of all types. Block **20** links to Block **22**, which is illustrative of channel A . . . Block **20** also links to Block **24**, which illustrates handling private message A. Block **20** also links to Block **26**, illustrative of handling out-of-band media via Block **28**, which is illustrative of a Web browser or auxiliary computer program. Block **20** also links to Block **30**, which illustrates asynchronous status message handling via Block **32**, illustrative of user interface objects windows and screens.

De/multiplexing via API provides a "virtual connection" between Channel, Private Message, and Multimedia objects in the controller computer **3** and each participator computer **5**. An alternate architecture is to allow for a separate connection between each object so that multiplexing/demultiplexing is not necessary and each object handles its own connection. This would influence system performance, however.

Turning now to FIG. **3**, a data and communications dependency diagram controller group channel structure is illustrated. Beginning from what is designated as a portion of Block **10** the logic flows to Block **34** to consider JOIN, LEAVE, STATUS, SETCHAN API instructions. Block **34** examines member list maintenance instructions, accessing Block **36** to check permissions, list users, and change attributes. Note the exploded window **38** shows a display of member information including a user's name, personal information, and attributes/properties/permissions (operations involving the subsequently discussed tokens), i.e., stored per channel attributes under each member. In any case, confirmation or denial of access is communicated via Block **40** for multiplexing return of status messages to a target object.

From the portion of Block **10**, the logic flows to Block **42** for MESSAGE and MODMSG API instructions. Block **42** tests which of the two instructions were received, and for MODMSG, the logic flows to Block **44**, which tests whether

6

the user is a moderator. If the user is not a moderator, the logic flows to Block **46**, which sends a denial message through Block **40**. If, however, in Block **44** the user is a moderator, the logic flows to Block **48** for a repeat to all list members who are permitted to see the message, via Block **40**.

Returning to Block **42**, if MESSAGE is detected, the logic flows to Block **50**, which tests whether a user has post permission. If the user has post permission, the logic flows to Block **48**, etc. If the user does not have post permission, the logic flows to Block **52** to forward the message to moderators for approval, via Block **40**.

Additionally, the logic flows from Block **10** to Block **54** for a URL API instruction. Block **54** tests whether the user has graphical multimedia communication privileges, and if not, the logic flows via Block **56**, which sends a denial message via Block **40**. Otherwise, if the user does have graphical multimedia communications privileges in Block **54**, Block **58** sends graphical multimedia information to all approved users via Block **40**.

Turning now to FIG. **4**, central controller loop communications is illustrated. For the data on central poll point **58** (see Appendix POLL_POINT), a "do" loop begins at Block **60** for each connection. Block **62** tests whether bytes are available on the data stream. If they are, the bytes are added to user space FIFO per connection at Block **64**, leading to Block **66**, which tests whether there are any more connections. Note that in FIG. **4**, if there are no more bytes available in Block **62**, the logic skips to Block **66**, and if Block **66** is not finished with all connections, the loop returns to Block **62**. When all connections have been completed in Block **62**, the logic flows to Block **68**, which looks for an available complete data instruction for any connection by extracting packets byte-wise from the FIFO. Thereafter, Block **70** tests whether there is a complete response available from the participator computer. If the response is complete, the logic flows to Block **72** which, using a command type, demultiplexes into an appropriate object (output FIFOs may be filled here for any connection). The logic from Block **72** joins the "no" branch from Block **70** at Block **74**, which enables unblocking for writing connections for only connections with data available to write, looping back to Block **58**.

FIG. **5** shows a client channel data structure and information flow diagram. From a message that is demultiplexed by message type, there are six possibilities: ERROR MESSAGE, MESSAGE, STATUS, JOINCHANNEL, LEAVECHANNEL, and MODMSG. ERROR MESSAGE is communicated to Block **76**, where the error message is displayed to the transcript in the transcript area of Block **78**. MESSAGE is communicated to Block **80** where the message is immediately added to the transcript in transcript area **78**. STATUS is communicated to Block **82** to update user data structure; JOINCHANNEL is communicated to Block **84** to add a user from the member list and display the change; and LEAVECHANNEL is communicated to Block **86**. From Block **82**, Block **84**, and Block **86**, the logic flows to Block **88**, which includes a member list, a member identifier, known attributes/permissions/properties, and personal information. From Block **88**, the logic proceeds to Block **90**, a member list area, and on to Block **92** to compose a request to change a member attribute. This "SETCHAN request is then communicated to Block **94**, which is the multiplexer leading to the controller computer connection.

MODMSG is communicated to Block **96**, which sends the message to the moderation area of Block **98**, and then to Block **100** to resubmit a member message as approved, thereby conveying a MODMSG request to Block **94**.

Note that a response is prepared in the response area of Block 102. If the response is a standard message, it is conveyed to Block 104 to compose the response into a controller message, thereby sending a MESSAGE request to box 94. If, however, the message is a graphical information submission, the logic flows from Block 102 to Block 106 to compose the graphical information submission into a controller message, thereby sending a URL request to Block 94.

FIG. 6 is a participator software out-of-band multimedia information flow diagram, which begins with Block 26, the multimedia type patch point. Block 26 leads to Block 102, which tests whether there is an internally handlable multimedia type. If not, Block 104 looks up a suitable agent for data type presentation, which leads to Block 106, which tests whether an agent was found. If not, Block 108 reports location of data to the user for future referencing. If the agent is found in Block 106, the logic flows to Block 110, which invokes the agent with a data reference to present the data.

If the multimedia type is internally handlable from Block 102, the logic flows to Block 112, which tests whether this is a member associated image. If it is a member associated image, Block 114 displays the image next to member identity information, and if it is not, the logic flows to Block 116, which tests if this is a member public data reference (e.g., a URL). If a URL is detected at Block 116, Block 118 invokes an external data type viewer only on demand of the operator of the participator software, and otherwise Block 120 stores the reference for future use by the operator of the participator software, or treats the reference as an externally handled multimedia type (at the user's option).

With further regard to the manner of interaction between the controller computer 3 and the participator computers 5, and their respective computer programs 2 and 4, includes a moderation capability that is controlled, or arbitrated, pursuant to system 1 recognizing user identity. Note that using the user identity for moderation purposes is a use additional to the use of the user identity for security purposes.

One embodiment of the present invention is to bring chat capability to the internet and World Wide Web. However, another embodiment involves non-internet relay chat. In either embodiment, System 1 is state driven such that synchronous and asynchronous messages can be communicated. For an asynchronous notification, each message is sent through the system 1 (API), which updates the information on the output device of the participator computers 5. For a synchronous notification, a participator computer 5 must interrogate the system 1 for a message.

With regard to the arbitrating of the controller computer 3 is directed by the controller computer program 2 to use "identity tokens", which are pieces of information associated with user identity. The pieces of information are stored in memory in a control computer base, along with personal information about the user, such as the user's age. The control computer database serves as a repository of tokens for other programs to access, thereby affording information to otherwise independent computer systems. In the database, the storage of tokens can be by user, group, and content, and distribution controls can also be placed on the user's tokens as well as the database.

Each token is used to control the ability of a user to gain access to other tokens in a token hierarchy arbitration process. The arbitration also includes controlling a user's ability to moderate communications involving a group or subgroup of the participator computers 5. Once in a group, temporary tokens are assigned for priority to moderate/submoderate groups (a group is sometimes known as a channel in multiplexing terminology).

Accordingly, tokens are used by the controller computer 5 to control a user's group priority and moderation privileges, as well as controlling who joins the group, who leaves the group, and the visibility of members in the group. Visibility refers to whether a user is allowed to know another user is in the chat group.

Tokens are also used to permit a user's control of identity, and in priority contests between 2 users, for example, a challenge as to whether a first user can see a second user.

Censorship, which broadly encompasses control of what is said in a group, is also arbitrated by means of the tokens. Censorship can control of access to system 1 by identity of the user, which is associated with the user's tokens. By checking the tokens, a user's access can be controlled per group, as well as in giving group priority, moderation privileges, etc.

Censorship also can use the tokens for real time control of data (ascii, text, video, audio) from and to users, as well as control over multimedia URLs—quantity, type, and subject.

With regard to controlling communications in a group (which is in essence a collection of user identities), control extends to seeing messages, seeing the user, regulating the size of the communication, as well as the ability to see and write to a specific user. Control further extends to the ability to send multimedia messages.

Note that tokens for members in group can involve multiples formed in real time, say, within the span of a conversation. For example, for private communication, tokens are immediately formed to define a group of 2 users. Hierarchical groups within groups can also be formed, with each inheriting the properties of the group before it. Thus, a subgroup can include up to all members or more by adding any surplus to the former group.

With further regard to the controller computer 3, e.g., a server, information is controlled for distribution to the user interfaces at selected ones of the participator computers 5. The controller computer program, in one embodiment, can be a resident program interface (such as a JAVA application). There can be a token editor object (window/tear down, etc.) per group, private communication, user, channel listings, user listings, etc. Each can link up in a token hierarchy for arbitration control.

The controller computer 3, by means of the controller computer program 2, keeps track of states and asynchronous messages as well as generating a synchronous message as a user logs in or interrogates system 1.

With regard to multimedia information messages 8, such messages are of independent data types, e.g., audio/video data types. The content of the message (e.g., a URL) permits the System 1 to automatically determine the handling of the message: either the Controller Computer 3 passes the content of Message 8 directly, or the Controller Computer 3 determines from the Message 8 how to find the content, say via Netscape. Accordingly, Message 8 can communicate video and sound (or other multimedia, e.g., a URL) to users, subject only to the server arbitration controls over what can be sent.

Turning now to an illustration of using the invention, the session starts with verifying the user's identity (at FIG. 7). The login/password screen is shown, and the user enters his/her assigned login/password combination and clicks the "Login To Chat" button. If the password was entered correctly, a confirmation box appears on the screen.

Then the channel list area is shown at FIG. 8. The Channel List area is a window which shows a list of all of the groups currently on the server in active communication. Because no one is yet connected in this example, there are no groups currently available on the screen.

To create a new group, the “New Channel” option is selected from a pull-down menu (at FIG. 9). The name of the channel is entered by the input device 7.

If the user has permission (this one does), a new channel is created for the group (at FIG. 10). The window that displays the channel area has three regions: the bottom region, where responses are entered; the largest region, where a transcript of the communication is followed; and the rightmost region, which lists the group’s current members. This list is continuously updated with asynchronously generated status messages received immediately when a new member joins the group. Only “DMARKS” is currently in this group. The “MWU” is the properties currently associated with DMARKS—the ability to moderate, write to the channel, and send multimedia messages.

A new member has joined the channel, and the member list status area is updated right away (at FIG. 11). This new member has a login of “ME.”

The user DMARKS now types “hello there” into the response area and presses RETURN (at FIG. 12). This message is passed to the controller computer 5, which sends the message to all channel members, i.e., those using participator computers 5, including DMARKS.

The user ME now sends a message to the controller: “hi there” (at FIG. 13). This message is also sent to all members by the controller computer 5. Now user DMARKS clicks (using input device 7, a mouse) on the name of the user “ME” in the member list window. The participator software 4 will now create a private message window, so that the users ME and DMARKS can exchange private messages. Private messages are only sent to the intended recipient by the controller, and no one else.

A private message window appears in response to DMARKS’s request to open private communications with ME (at FIG. 14). Now DMARKS types a message into the private message window’s response area to ME: “this message is seen only by the user ME.” When complete, the participator software 4 will forward this message to the controller computer 3.

In response, the user ME has entered “This is the private message response that is only seen by the user DMARKS,” which has been forwarded to user DMARKS (at FIG. 15). This message is displayed immediately on DMARKS’s window.

DMARKS now returns to the channel window for the group “TESTCHANNEL” (at FIG. 16). To modify the permission attributes associated with user ME on the channel TEST CHANNEL, DMARKS (who is a moderator of the channel), clicks on the user ME in the member list to select ME, pulls down the Moderator menu, and selects “Toggle Moderator.” This removes the moderator privileges from ME.

As a result of the attribute revocation, the “M” has disappeared from next to ME’s name in the member list (at FIG. 17), indicating that the property is no longer associated with the user ME.

Now DMARKS returns to the Channel List window (at FIG. 18). DMARKS wishes to fully moderate the contents of the channel TESTCHANNEL, censoring all unwanted communications to the channel. DMARKS returns to the channel list, and selects the channel TESTCHANNEL by clicking on its name in the channel list.

Now DMARKS selects the “Toggle All Posting” option in the Maintenance pull-down menu (at FIG. 19). This will turn off the channel property “posting,” (or sending communications to the channel without moderator approval) which will be indicated by the removal of the letter “P” from next to the name TESTCHANNEL (at FIG. 20).

Now the letter “P” is removed from after the name TESTCHANNEL in the Channel List window (at FIG. 21), indicating that this channel is now moderated and will only have free posting ability by designated members.

Now, type user ME (who is also on channel TESTCHANNEL) wishes to send communications: “this will not be written directly to the channel” (at FIG. 22). The controller, instead of sending it immediately to the channel to be seen by all members, will instead forward the message to the moderators for approval. The moderator, DMARKS, will then see the message on the Moderation Window, which provides a preview of any messages to be sent. To approve a message for general viewing, DMARKS now clicks on the message.

Now that DMARKS has clicked directly on the message, it is displayed inside the group’s Channel window for all members to see (at FIG. 23).

DMARKS now wishes to send a graphical multimedia message. This implementation sends graphical multimedia images by allowing a channel member to specify an Internet URL of a graphical multimedia resource to be presented to the group members. In this example, DMARKS wishes to the URL corresponding to the World Wide Web home page of American Information Systems, Inc. to the channel members. DMARKS enters the URL into the response window, and selects “Send URL” from the Moderator pull-down menu (at FIG. 24).

The controller computer 5 now passes the URL to the channel members. This participator software 4 performs two actions in response to the graphical multimedia display request. The first is to put the name of the URL onto the transcript of the group’s channel, so that it can be read by group members. The second response is to have the participator software show the data associated with the graphical multimedia message in a human interpretable way (at FIG. 25). To do this, the participator software 6 either uses built in rules to decide how the graphical multimedia data is to be presented, or locates another program suitable to present the data. In this case, the software 6 is utilizing Netscape Navigator[®], a program for displaying graphical multimedia documents specified by a URL (at FIG. 26). Inside the Navigator window, the graphical multimedia content, the home page of AIS, is shown.

Finally, DMARKS wishes to manually modify the attribute tokens associated with the user (at FIG. 27). The user invokes the Property Editor dialog, which allows the user to view and change the tokens associated with a user. A property of a given user is determined by the Identifier and Property names. An old value of the property is shown, and a token value can be changed in the “New Value” field. With this property editor, a user with sufficient permissions (tokens) can change any of the tokens or security parameters of any user, or a user’s ability to change security parameters can be restricted.

To start with an alternate embodiment using a text-based interface, a user is presented by the login/password screen (at FIG. 28). This screen is where a user enters the information that proves his/her identity. The user must now enter his/her login and password to identify themselves.

After the user has been identified by the controller the Channel List screen appears (at FIG. 29). The names of channels and their associated properties are shown on this screen. By using the arrow keys and highlighting the desired channel, ME may enter any publicly joinable group. Currently, there is only one group TESTCHANNEL, which ME will join.

Now the screen for the channel TESTCHANNEL appears (at FIG. 29). The screen is split into four regions. The bottom left region is the response line, where messages users wish to

11

enter appear. The upper left region is the transcript area where the communications of the group's channel appear as they occur. The upper right region is the Member List region, where a continuously updated list of members' names appear, with their attributes.

A message appears in the transcript area. The controller has forwarded a message to the group from DMARKS, "hello there" (at FIG. 31), which is seen by all members of the group, including ME. Now ME will respond, by entering "hi there" into the response area.

When ME is finished entering his response, the participator software forwards the response to the controller, which sends it to the members of the channel. In the transcript area, the participator software notifies the user that it has received a private message from DMARKS, which is waiting inside the private message screen. To see the private message, ME presses the private message screen hot key.

A private message screen appears (at FIG. 32), and the private message from DMARKS is at the bottom of the transcript area. Now to reply, ME types his response into the response area.

Now ME will return to the screen for the channel TESTCHANNEL. The member list area has changed because DMARKS has revoked ME's moderator permission. ME is no longer permitted to see the permissions of other users, so this information has been removed from his display (at FIG. 33). The only information he can see now is who is moderator (at FIG. 34). A "*" next to the identifier of a member of the group indicates the member is a moderator of the group. ME is no longer a moderator, and therefore a "*" does not appear the identifier ME.

To further exemplify the use of the present invention, the following is a transcript of communications produced in accordance herewith.

POWERQUALITY JOHNMUNG: unclear about meaning of "first contingency"

POWERQUALITY SAM: mike, that is correct on IEEE 519

POWERQUALITY SKLEIN: In assessing network security (against outage) the first contingencies are tested to see how the power system should be reconfigured to avoid getting a second contingency and cascading into an outage.

POWERQUALITY MSTEARS: These outages point out the need for reliability as part of the overall customer picture of PQ

POWERQUALITY BRIAN: Hi Jennifer, hit crt-p for private message

POWERQUALITY SKLEIN: In simpler terms, a single point failure shouldn't crash the system.

POWERQUALITY SKLEIN: Are we all chatted out?

POWERQUALITY ANDYV: brian, johnmung has been banned!!! why?

POWERQUALITY BRIAN: no way, new subject

POWERQUALITY BRIAN: just a sec, andy

POWERQUALITY BRIAN: No banning on this channel, John is back on

POWERQUALITY TKEY: ieee 519 limits the harmonic current a customer can inject back into the pcc and limit the vthd the utility provides at the PCC

POWERQUALITY JOHNMUNG: thanks guys, for unbanning me—i've been thrown out of better places than this!

POWERQUALITY BRIAN: New subject . . . now . . .

POWERQUALITY BRIAN: good one john . . .)

POWERQUALITY MSTEARS: For critical facilities dual feeds or other backup capability need to be economically evaluated to keep the facility in operation

POWERQUALITY SAM: John, I remember that club very well

12

POWERQUALITY JOHNMUNG: question: please comment on frequency of complaints involving spikes, sags or harmonics

POWERQUALITY WARD: Problems caused by sags is the main complaint.

POWERQUALITY BRIAN: What subject does anyone want to see the next chat

POWERQUALITY WARD: Surges is probably next; harmonics really don't cause that many problems, although they are certainly there.

POWERQUALITY ANDYV: what is the solution ward?

POWERQUALITY TKEY: Agree they are the most frequent (sags) and the panel session on the cost of voltage sags at PES drew 110 people

POWERQUALITY SAM: harmonics tend to be an interior problem within a facility, rather than on the distribution system

POWERQUALITY WARD: The best solution is making the equipment less susceptible to sags. This requires working with the manufacturers.

POWERQUALITY ANDYV: won't that cost more

POWERQUALITY MSTEARS: The complaint of surges covers many things in the customers eyes sags have become a real problem because they are harder to resolve

POWERQUALITY GRAVELY: John—The latest EPRI results confirms the 90+ % of the time SGS are the problem and short term ones.

POWERQUALITY WINDSONG: What is the topic for the 25??

POWERQUALITY WARD: Each problem can be dealt with as it occurs, but the time involved gets very expensive.

POWERQUALITY JOHNMUNG: making equipment less susceptible causes legal problems for manufacturers—as each improvement can be cited by complainant as example of malfeasance

POWERQUALITY WARD: AndyV: The cost to the manufacturer increases. The overall cost to everyone involved decreases.

POWERQUALITY TKEY: customer pays any way you cut it, if the eqpt is more immune customers pay only once instead of every time the process fails

POWERQUALITY BRIAN: The topic is regarding Power Quality

POWERQUALITY BRIAN: This chat is available for everyone 24 hours a day

POWERQUALITY ANDYV: dorr>>will the manufacturer spend more to produce a better product

POWERQUALITY WARD: And as Tom says, the cost to the customer is far less.

POWERQUALITY BRIAN: This chat will be functioning 24 hrs/day

POWERQUALITY BRIAN: please use it

POWERQUALITY BRIAN: The next panel discussion is Nov 15th

POWERQUALITY WARD: Andy, that's where standards come in.

POWERQUALITY SKLEIN: Is the customer capable of resolving the fingerprinting among the manufacturers and utilities?

POWERQUALITY DDORR: andy, only if the end users create a market for pq compatible eqpt by demanding better products

POWERQUALITY MSTEARS: The manufacturers problems in including fixes is being competitive with some who doesn't provide the fix

POWERQUALITY ANDYV: how will we educate the general consumer?

13

POWERQUALITY GRAVELY: Is it possible to have a basic theme topic or some core questions for 15 Nov chat?

POWERQUALITY WARD: Stan, the customer cannot be expected to resolve the fingerprinting. The manufacturers and utilities need to work together.

POWERQUALITY ANDYV: about power quality and reliability?

POWERQUALITY SKLEIN: If electric power is going to be treated as a fungible commodity, there has to be a definition. Like, everyone knows what number 2 heating oil is.

POWERQUALITY SAM: Ideally a manufacturer would not be able to compete if they don't add the protective function in their products, but alot more public education is required before we get to this point.

POWERQUALITY WARD: Andy, there are many ways to educate the customers, but they require a lot of contact between the utility and the customers. The Western Resources Power Technology Center in Wichita is doing it, just as an example.

POWERQUALITY DDORR: standard power vs premium power is one solution as is std qpt vs Pq compatible eqpt

POWERQUALITY SKLEIN: I want to buy number 2 electric power and to be able to check the nameplates of my appliances to be sure they can take it. Just like I buy regular gasoline.

POWERQUALITY MSTEARS: Sam—I agree, that is partly the utilities responsibility since we serve the customers

POWERQUALITY BBOYER: What differentiates number 2 from number 1?

POWERQUALITY SKLEIN: I used the analogy of number 2 heating oil. I don't know what number 1 heating oil is.

POWERQUALITY DDORR: Number two has cap switching and all the normal utility operational events while number one is much better

POWERQUALITY SKLEIN: Perhaps we can just say regular vs high test.

POWERQUALITY SAM: mike, yes a joint effort between the utility, manufacturer and standards jurisdictions is a goal for utilicorp as we move forward with offering from our strategic marketing partners, and bring PQ technologies to the public

POWERQUALITY TKEY: We are finding that many mfgs want to produce pq compatible equipment, but they have no clue as to what to test for

POWERQUALITY ANDYV: Tom>>will the IEC standards help?

POWERQUALITY TKEY: Its up to the utility to help define normal events IEC will take time

POWERQUALITY SKLEIN: You can't have a commodity product with all the variation in specifications we have been discussing. It has to be regular, premium, and super premium or it won't work.

POWERQUALITY JOHNMUNG: Tom as a former manufacturer i sympathize—your work at PEAC is invaluable but anecdotal knowledge from utility people on the firing line is equally important

POWERQUALITY TKEY: Super premium, does that mean a UPS?

POWERQUALITY ANDYV: how do you stop a facility from affecting you super-premium power?

POWERQUALITY TKEY: John, Good Point

POWERQUALITY SAM: Tkey, a ups, local generation or redundant service

POWERQUALITY SKLEIN: This is what I meant earlier by electricity being a non-virtualizable service. You can't make each customer see the power system as though they had their own dedicated generating plant.

14

POWERQUALITY BRIAN: THE CHAT CHANNEL WILL BE OPEN 24/HRS/DAY 7 DAYS A WEEK

POWERQUALITY TKEY: I must sign out for about 5 minutes but I'll be back

5 POWERQUALITY BRIAN: OK TOM

POWERQUALITY MSTEARS: PQ for facilities need to be done with a system perspective to to get the right resolution
POWERQUALITY BBOYER: Andy's question is still relevant—how do stop a facility from downgrading utility service to other customers?

10 POWERQUALITY BRIAN: MIKE>>LETS SWITCH BACK TO RETAIL WHEELING
POWERQUALITY WARD: You work with that customer to do whatever is needed to correct their disturbances.

15 POWERQUALITY BBOYER: Be more specific

POWERQUALITY MSTEARS: Interaction between facilities can be evaluated and designed for

POWERQUALITY JOHNMUNG: as a key to hardening it helps to identify the most sensitive circuits, i.e. microprocessor logic, test for vulnerability under common surges, sags, rfi, and then notify users that their equipment contains these subsystems—for a start

POWERQUALITY BRIAN: hi DOUG

25 POWERQUALITY GRAVELY: Brian: Are you saving this session as a file? Can we get a list of chat session participants?

POWERQUALITY BRIAN: s, we may

POWERQUALITY DMARKS: gravelly: hit TAB and use the arrow keys to page through the list of participants

30 POWERQUALITY SKLEIN: Will the session be available for downloading?

POWERQUALITY BRIAN: yes, Mike we will publish in PQ Magazine

POWERQUALITY WARD: Part of the agreement for high quality power should be that the customer receiving the power will not disturb the utility system.

POWERQUALITY BRIAN: if john let's us . . .

POWERQUALITY GRAVELY: I tried that, however, netcruiser has a software problem and I cannot see all of the names.

40 POWERQUALITY SAM: most utilities rules and regulations already require that a customer not put anything back out on the utility system

POWERQUALITY BRIAN: MIKE G.>>WE WILL PUBLISH THIS IN PQ MAG NEXT MONTH IF ASNDY LETS US

45 POWERQUALITY BRIAN: HOW ABOUT IT ANDY?

POWERQUALITY ANDYV: ok

POWERQUALITY BRIAN: COOL

POWERQUALITY WARD: Standards will have to be set for what constitutes a disturbance, and then the utility should work with customers, install filters, etc., to be sure they stay within the rules.

POWERQUALITY BRIAN: THANKS ANDY

55 POWERQUALITY ANDYV: a meeting review or a summary of events

POWERQUALITY GRAVELY: It would be good to take a few minutes to recommend how the 15 Nov session could be more effective.

60 POWERQUALITY BRIAN: A SYNAPSE OF THIS CHAT WILL BE IN NEXT MONTHS PQ MAG

POWERQUALITY WINDSONG:

POWERQUALITY SKLEIN: I don't get PQ mag. Will it be on the Net?

65 POWERQUALITY BRIAN: STAN SIGN UP FOR IT ON OUR HOME PAGE

POWERQUALITY DOUGC: the transcript of this conference will be available on the EnergyOne pages.

15

POWERQUALITY BRIAN: YOU CAN SIGN UP ON LINE
POWERQUALITY BRIAN: HTTP://WWW.UTILICORP.
COM

POWERQUALITY WINDSONG: Good comment Gravely
Comments from the users would be greatly appreciated!!

POWERQUALITY SAM: PQ magazine is available online
on the UCU internet bulletin board, <http://www.utilicorp.com>

POWERQUALITY ANDYV: or link from powerquality.com
POWERQUALITY BRIAN: YOU CAN GET A FREE MAG

SUBSCRIPTION FROM UTILICORP'S HOME PAGE
POWERQUALITY SKLEIN: Thanks

POWERQUALITY BRIAN: ALSO, THERE IS A PQ
FORUM ON OUR HOME PAGE

POWERQUALITY JOHNMUNG: for nov 15 shall we pick
five key topics? suggest health care, energy storage rfi/emc as
a few topics—also new gas turbine 25 kw generator just
announce today—just some suggestions

POWERQUALITY BRIAN: GOOD SUGGESTION JOHN
POWERQUALITY ANDYV: lets develop an outline of top-
ics for next time.

POWERQUALITY BRIAN: OK

POWERQUALITY GRAVELY: One suggestion for 15
Nov—Have participants place a list of desired topics on your
other chat box and prioritize by interest level.

POWERQUALITY SKLEIN: How about deregulation and
retail wheeling.

POWERQUALITY BRIAN: COMMENTS SHOULD BE
SENT TO ME BY EMAIL POWERQUALITY BRIAN:

BSPENCER@UTILICORP.COM POWERQUALITY
BRIAN: 15 minutes remaining

POWERQUALITY ANDYZYREK: Let's discuss the new
standard IEEE 1159.

POWERQUALITY ANDYV: may be we could generate an
online questionnaire to see what people are needing discussed.

POWERQUALITY BRIAN: but the chat is available for 24
hrs/day 7 days a week

POWERQUALITY ANDYV: what does IEEE1159 address?
POWERQUALITY BRIAN: Please send all suggestion to me
for our next chat

POWERQUALITY BRIAN: Bobbin is not banned now

POWERQUALITY BRIAN: my fault

POWERQUALITY ANDYZYREK: New PQ measuring
techniques. We have not received our issue yet.

POWERQUALITY ANDYV: You should have it my now.

POWERQUALITY BRIAN: Bobbin is not banned anymore

POWERQUALITY ANDYV: you can e-mail me or john at:
editors@powerquality.com

POWERQUALITY BRIAN: is two hours right fdo rhtis fea-
ture

POWERQUALITY JOHNMUNG: do i understand that
many programmable logic controllers can be hardened by
addition of simple CVT like a sola?

POWERQUALITY ANDYZYREK: Yes, but it is being deliv-
ered by snail mail.

POWERQUALITY ANDYV: no 2nd class

POWERQUALITY BRIAN: 15 minutes to go

POWERQUALITY ANDYV: Please e-mail me you complete
name and address and I will mail you one today 1st class . . .
now is that serice or what?

POWERQUALITY BRIAN: Is two hours long enough for
tthis chat?

POWERQUALITY TKEY: Im back

POWERQUALITY WARD: Brian, I think two hours is about
right.

POWERQUALITY BRIAN: hi tom

POWERQUALITY BRIAN: good . . .

POWERQUALITY ANDYV: yes I agree 2 hrs

16

POWERQUALITY BRIAN: anyone else

POWERQUALITY ANDYV: it the time of day correct?

POWERQUALITY BRIAN: questions now . . .

POWERQUALITY SKLEIN: The topic foremost in my mind
right now is what to eat for lunch. I enjoyed the discussion,
which I understand has been historic in some sense. But I
think I will sign off now and go eat.

POWERQUALITY SAM: 2 hours seems to work very well

POWERQUALITY DANIELH: time of day is good

POWERQUALITY BILLMANN: 2 hrs is fine

POWERQUALITY MSTEARS: Two hours work well, the
middle of the day allows east and west coast to be involved

POWERQUALITY BRIAN: good, Will everyone be back for
the next chat

POWERQUALITY GRAVELY: Brian, I will forward my
recommendations on email, thanks.

POWERQUALITY BILLMANN: yes i'll be back

POWERQUALITY ANDYZYREK: Brian, would it be pos-
sible to have a forum published on your home page prior to

Nov 15.

POWERQUALITY BRIAN: I would like to do another chat
before Nov 15th, any thoughts

POWERQUALITY ANDY: U bet

POWERQUALITY SAM: I believe that this chat may set an
attendance record for most participants during a first session

POWERQUALITY JOHNMUNG: a parting thought—"har-
monics make the music rich, they make the tone inspringing—
harmonics in your power line WILL BLOW THE BUILD-
INGS WIRING" tIM MUNGENAST

POWERQUALITY BRIAN: Your're all invited to return

POWERQUALITY BRIAN: the next chat

POWERQUALITY BRIAN: This chat feature will help set
standards of how we view our industry

POWERQUALITY WARD: For me this was two hours very
well spent, and it was quite enjoyable.

POWERQUALITY BRIAN: Tell a colleague about our chat
Nov 15th

POWERQUALITY BRIAN: Thanks Ward

POWERQUALITY BRIAN: I would like to do this on a
weekly basis, any thoughts yet

POWERQUALITY GRAVELY: John: talk it up in Ger-
many!!

POWERQUALITY ANDY: I would like to thank utilicorp
and everyone envolved.

POWERQUALITY BRIAN: Thanks Andy for your help

POWERQUALITY WARD: Did this notice go out to the
Power Globe mailing list?

POWERQUALITY BRIAN: No, but could help us Ward with
that

POWERQUALITY BRIAN: Lets all get the word out about
this chat

POWERQUALITY WARD: I'm on the list and will be glad to
forward anything you wish to it.

POWERQUALITY BRIAN: Please use it whenever you wish,
even schedule your own chats whenever

POWERQUALITY JOHNMUNG: MANY THANKS TO
UTILICORP AND ALL INVOLVED—FROM AN OLD
STEAM BOATER :-)

POWERQUALITY BRIAN: thanks ward

POWERQUALITY BRIAN: Hi duane

POWERQUALITY BRIAN: This chat is offically over, but
do stick around for foir more chatting

POWERQUALITY BRIAN: Thanks to all, cya on Nov 15th

POWERQUALITY MSTEARS: Ward, Tom, and John I
appreciate your participation

POWERQUALITY BRIAN: Thanks Guys and
Ladies!!!!!!!!!!!!!!

POWERQUALITY SWPPD: WHAT IS HAPPENING ON NOV. 15
 POWERQUALITY BRIAN: our next chat with a panel of experts
 POWERQUALITY BRIAN: topic yet to be decided
 POWERQUALITY DPSWOBO: Hi Brian, Sorry I was on the phone and could not respond right away. Did I get the time incorrectly for the chat?
 POWERQUALITY BRIAN: please send us a suggestions
 POWERQUALITY ANDY: good bye ;-)
 POWERQUALITY BRIAN: Yeah, but stick around to chat with some friends
 POWERQUALITY BRIAN: We had a total of 50 people and avg of 20 people at one time
 POWERQUALITY BRIAN: Thanks everyone!!! Lunch Time
 POWERQUALITY BRIAN: Next Chat Nov 15th at 10-12 ct
 POWERQUALITY BRIAN: But this chat line is available 24 hrs/day/7 days a week
 POWERQUALITY BRIAN: Please use it whenever
 POWERQUALITY GRAVELY: Thanks to the panel and Utilicorp for the session!
 POWERQUALITY BRIAN: Talk to your colleagues and friends about any particular topic
 POWERQUALITY BRIAN: Come see our home page for new topics and chats
 POWERQUALITY BRIAN: http://www.utilicorp.com
 POWERQUALITY BRIAN: Thanks Power Quality Assurance Magazine and All our panel members
 POWERQUALITY BRIAN: :)
 POWERQUALITY SWPPD: MISSED THIS SESSION. ICAN WE GET HARD COPY INFO?
 POWERQUALITY BRIAN: yes swwp, it will be published in pq mag and our home page
 POWERQUALITY BRIAN: catch our next session on nov 15th
 POWERQUALITY BRIAN: 10-12 ct
 POWERQUALITY SWPPD: THANKS A BUNCH!!
 POWERQUALITY SWPPD: GOOD BYE!
 POWERQUALITY BRIAN: no prob
 POWERQUALITY BRIAN: cya
 POWERQUALITY DESWETT:
 POWERQUALITY TKEY: Good session brian, dorr and I will be signing off now, look forward to the next session
 POWERQUALITY DPSWOBO: Thanks for the info on the next session, we will get on next time
 POWERQUALITY DMARKS: I hope everyone enjoyed this session.
 POWERQUALITY MSTEARs: I am logging off Thanks
 POWERQUALITY SAM: This is Tony and I am watching the action . . . we made history. Great work guys.
 POWERQUALITY BRIAN: Lunch time
 POWERQUALITY BRIAN: Next chat is nov 15th
 POWERQUALITY BRIAN: 10-12 ct
 POWERQUALITY BRIAN: please continuie to look at utilicorp's hp
 POWERQUALITY BRIAN: for more info
 POWERQUALITY BRIAN: email if you have any questions regarding the chat
 POWERQUALITY BRIAN: bspencer@utilicorp.com
 POWERQUALITY BRIAN: later
 SUPPORT BRIAN: hi guys
 SUPPORT BRIAN: success
 SUPPORT BRIAN: BRIAN: yes!!
 SUPPORT BRIAN: thanks for the help
 SUPPORT BRIAN: cya

POWERQUALITY BRIAN: next chat on Nov 15th
 POWERQUALITY BRIAN: 10-12 ct
 POWERQUALITY BRIAN: any suggestion on topics please contact me by email
 POWERQUALITY BRIAN: bspencer@utilicorp.com
 POWERQUALITY BRIAN: hi chuck
 POWERQUALITY BRIAN: hi randy
 POWERQUALITY CPREECS: hello brian
 POWERQUALITY BRIAN: How are you chuck
 POWERQUALITY CPREECS: how has the participation been?
 POWERQUALITY BRIAN: I am sorry you missed the official chat, but do come back at any time for some chatting
 POWERQUALITY BRIAN: great 20 people avg. 50 total people
 POWERQUALITY CPREECS: ? yes, i got some conflicting info
 POWERQUALITY BRIAN: transcripts will be in PQ mag next month and on utilicorp's home page
 POWERQUALITY CPREECS: what were the topics discussed?
 POWERQUALITY BRIAN: how is that chuck
 POWERQUALITY BRIAN: power quality, standards,
 POWERQUALITY BRIAN: retail wheeling
 POWERQUALITY BRIAN: cya, lunch time
 POWERQUALITY CPREECS: later
 POWERQUALITY BRIAN: bye all
 POWERQUALITY BRIAN: email me chuck
 POWERQUALITY RB: sorry I missed it. I got 12-2 est off the net. bye.
 POWERQUALITY BRIAN: sorry RB
 POWERQUALITY BRIAN: miss information
 POWERQUALITY BRIAN: next chat is 10-12
 POWERQUALITY BRIAN: ct
 POWERQUALITY BRIAN: nov 15th
 POWERQUALITY BRIAN: bye
 POWERQUALITY RB: thanks
 POWERQUALITY BRIAN: no prob, tell all
 POWERQUALITY ANDY: Is anyone still here talking about power quality?
 POWERQUALITY DAVE: Just signed on that is what I was trying to find out
 POWERQUALITY ANDY: the PQ chat was running from 11:00-1:00 est
 POWERQUALITY ANDY: Were you involved then?
 POWERQUALITY DAVE: No I just got a chance to sign on now
 POWERQUALITY ANDY: there were some great discussions.
 POWERQUALITY ANDY: The transcripts will be available to down load at utilicorp.com Brian Spencer says.
 POWERQUALITY ANDY: What is your experience in PQ
 POWERQUALITY DAVE: That is what I was looking for, are they available to down load now, I work in a data center and have worked with UPS systems for about 12 years
 POWERQUALITY DAVE: I did field service for Exide
 POWERQUALITY ANDY: Brian just went to Lunch in KS I don't know when it will availalbe.
 POWERQUALITY DAVE: Thanks for the Info on the downloads, I hope they do this again
 POWERQUALITY ANDY: so do I.
 POWERQUALITY DAVE: What is your experience on PQ
 POWERQUALITY ANDY: I am the editor or Power quality mag.
 POWERQUALITY DAVE: Good mag., I pick up alot in it
 POWERQUALITY ANDY: do your receive power quality assurance magazine?

19

POWERQUALITY ANDY: great glad to hear it.
 POWERQUALITY DAVE: We get it at work but I have asked to have it sent to my home
 POWERQUALITY ANDY: did you get the latest issue with the lighting on the cover?
 POWERQUALITY DAVE: Not yet, have seen it on line though
 POWERQUALITY ANDY: great.
 POWERQUALITY ANDY: any suggestion for editorial?
 POWERQUALITY DAVE:
 POWERQUALITY DAVE: no it is good
 POWERQUALITY ANDY: ok.
 POWERQUALITY ANDY: I am currently editing an article about VRLA battery charging.
 POWERQUALITY DAVE: I am working on a resonant problem with Utility and was looking for info
 POWERQUALITY ANDY: explain
 POWERQUALITY ANDY: by the way my e-mail is andy@powerquality.com
 POWERQUALITY DAVE: we are running a lot of 5th har. across our system in a large data center
 POWERQUALITY ANDY: I see
 POWERQUALITY ANDY: I will try to address this in an upcoming issue. may be march/april or even sooner.
 POWERQUALITY DAVE: we have 4800 kw of UPS cap on two transformers and we have alot of 5th on our other boards
 POWERQUALITY ANDY: If you are interested in writing up a case history including you solutions I would like to review it and poss. publish
 POWERQUALITY MSTONEHAM: Is this chat session still active?
 POWERQUALITY ANDY: YES
 POWERQUALITY ANDY: We can't get enough! !!
 POWERQUALITY DAVE: when we can get it fixed, It looks like we have a problem with input filtering on a couple of UPS,s
 POWERQUALITY ANDY: input fro the utility or a generator?
 POWERQUALITY DAVE: utility
 POWERQUALITY MSTONEHAM: I understand there was a chat session earlier today with some guest "chatters". Is there an archive of the discussion since I missed it?
 POWERQUALITY DAVE: we have 66 kv to 12 kv then to 480 v by 4 trans on property
 POWERQUALITY ANDY: What are you leaning towards in a solution dave
 POWERQUALITY ANDY: MTONEHAM>>yes but I don't know when. contact BSPENCER@utilicorp.com
 POWERQUALITY DAVE: the computer seem to have no problem, but we have alot of motor heating/bad PF
 POWERQUALITY MSTONEHAM: Thanks!
 POWERQUALITY DAVE: we currently are working with a consulant but I am looking for more info
 POWERQUALITY ANDY: will capacitors solve your problem
 POWERQUALITY ANDY:
 POWERQUALITY ANDY: there also is a forum under utilicorp.com where you can post you questions.
 POWERQUALITY DAVE: Each 600 kw UPS has Input filtering/may need trap for 5th
 POWERQUALITY ANDY: or you can access it form powerquality.com
 POWERQUALITY DAVE: thanks
 POWERQUALITY ANDY: Talk to ya later dave
 POWERQUALITY DAVE: is PQ.com your Mag
 POWERQUALITY ANDY: bye
 POWERQUALITY DAVE: bye

20

POWERQUALITY ANDY: yes
 POWERQUALITY DAVE: thanks
 POWERQUALITY ANDY: :-)
 POWERQUALITY MSTONEHAM:
 5 POWERQUALITY MSTONEHAM: Is anyone else hear? There doesn't seem to be much traffic.
 POWERQUALITY MSTONEHAM:
 POWERQUALITY CILCOJRG: Hello—is the conference over?
 10 POWERQUALITY CILCOJRG:
 POWERQUALITY CILCOJRG: hello
 POWERQUALITY BRIAN: yes
 POWERQUALITY BRIAN: the conference was from 10-12
 15 ct
 POWERQUALITY BRIAN: someone gave out the wrong information
 POWERQUALITY BRIAN: hello cilco
 POWERQUALITY BRIAN: anyone still there
 20 SUPPORT BRIAN: hi all
 SUPPORT BRIAN: anyone there
 POWERQUALITY BRIAN: jenny>>are you there
 POWERQUALITY CJBOUTCHER: is anyone here a utility employee?
 25 POWERQUALITY BRIAN: Hi chris
 POWERQUALITY BRIAN: how are you?
 POWERQUALITY CJBOUTCHER: hi brian it is quiet in here
 POWERQUALITY BRIAN: the conference was at 10:00 ct
 30 POWERQUALITY CJBOUTCHER: ah I see
 POWERQUALITY CJBOUTCHER: when is the next one?
 POWERQUALITY BRIAN: nov 15th
 POWERQUALITY BRIAN: 10-12
 POWERQUALITY BRIAN: ct
 35 POWERQUALITY CJBOUTCHER: is the channel open at other times?
 POWERQUALITY BRIAN: yes 24 hours a dfay
 POWERQUALITY CJBOUTCHER: but not much discussion?
 40 POWERQUALITY BRIAN: not right now,
 POWERQUALITY BRIAN: cya
 POWERQUALITY CJBOUTCHER: bye
 POWERQUALITY BRIAN: hi jenny
 POWERQUALITY JOSH: hello?
 45 POWERQUALITY BRIAN: hi dan
 POWERQUALITY BRIAN: hi dan
 POWERQUALITY BRIAN: are you awake yet?
 POWERQUALITY BRIAN: just giving present this a.m.
 POWERQUALITY BRIAN: :)
 50 POWERQUALITY BRIAN: who is guest96
 POWERQUALITY GUEST96: test

While a particular embodiment of the present invention has been disclosed, it is to be understood that various different modifications are possible and are within the true spirit of the invention, the scope of which is to be determined with reference to the claims set forth below. There is no intention, therefore, to limit the invention to the exact disclosure presented herein as a teaching of one embodiment of the invention.

60 I claim:

1. A method of communicating via an Internet network by using a computer system including a controller computer and a database which serves as a repository of tokens for other programs to access, thereby affording information to each of
 65 a plurality of participator computers which are otherwise independent of each other, the method including:

21

affording some of the information to a first of the participator computers via the Internet network, responsive to an authenticated first user identity; and
 affording some of the information to a second of the participator computers via the Internet network, responsive to an authenticated second user identity; and
 determining whether the first user identity and the second user identity are able to form a group to send and to receive real-time communications; and
 determining whether the first user identity is individually censored from receiving data in the communications, the data presenting at least one of a pointer, video, audio, a graphic, and multimedia by determining whether a respective at least one parameter corresponding to the first user identity has been determined by an other of the user identities;
 if the user identities are able to form the group, forming the group and facilitating receiving the communications that are sent and not censored from the second participator computer to the first participator computer, wherein the receiving is in real time and via the Internet network, and wherein, for the communications which are received and which present an Internet URL, facilitating handling the Internet URL via the computer system so as to find content specified by the Internet URL and presenting the content at an output device of the first participator computer, and
 if the first user identity is censored from the receiving of the data, not allowing the data that is censored to be presented from the second participator computer to the output device.

2. The method of claim 1, wherein the determining whether the first user identity is censored includes determining that the first user identity is censored from the data presenting the pointer.

3. The method of claim 2, wherein the computer system provides access via any of two client software alternatives, wherein both of the client software alternatives allow respective user identities to be recognized and allow at least some of the participator computers to form at least one group in which members can send communications and receive communications.

4. The method of claim 3, wherein each said user identity is associated with a respective particular user's stored access rights, which determine whether the corresponding said user identity is censored from receiving, in the communications, data presenting at least one of a pointer, video, audio, a graphic, and multimedia.

5. The method of claim 2, further including:
 determining whether the first user identity is censored from sending in the communications data presenting at least one of a pointer, video, a graphic, and multimedia;
 facilitating sending the communications that are not censored from the sending, from the first participator computer to the second participator computer, wherein the sending is in real time and via the Internet network; and
 if the first user identity is censored from the sending, not allowing the data that is censored to be sent from the first participator computer to the second participator computer.

6. The method of claim 5, wherein each said user identity is associated with a respective particular user's stored access rights, which determine whether the corresponding said user identity is censored from receiving, in the communications, data presenting at least one of a pointer, video, audio, a graphic, and multimedia.

22

7. The method of claim 2, further including determining whether at least one of the communications is censored based on content.

8. The method of claim 7, further including determining a user age corresponding to each of the user identities.

9. The method of claim 8, wherein each said user identity is associated with a respective particular user's stored access rights, which determine whether the corresponding said user identity is censored from receiving, in the communications, data presenting at least one of a pointer, video, audio, a graphic, and multimedia.

10. The method of claim 7, wherein each said user identity is associated with a respective particular user's stored access rights, which determine whether the corresponding said user identity is censored from receiving, in the communications, data presenting at least one of a pointer, video, audio, a graphic, and multimedia.

11. The method of claim 2, wherein the determining whether the first user identity is censored includes determining whether a parameter corresponding to the first user identity has been determined by an other of the user identities.

12. The method of claim 11, wherein each said user identity is associated with a respective particular user's stored access rights, which determine whether the corresponding said user identity is censored from receiving, in the communications, data presenting at least one of a pointer, video, audio, a graphic, and multimedia.

13. The method of claim 2, wherein the determining whether the first user identity and the second user identity are able to form a group includes determining from access rights stored by user in the database that neither of the user identities is censored.

14. The method of claim 13, wherein each said user identity is associated with a respective particular user's stored access rights, which determine whether the corresponding said user identity is censored from receiving, in the communications, data presenting at least one of a pointer, video, audio, a graphic, and multimedia.

15. The method of claim 2, further including determining a user age corresponding to each of the user identities.

16. The method of claim 15, wherein each said user identity is associated with a respective particular user's stored access rights, which determine whether the corresponding said user identity is censored from receiving, in the communications, data presenting at least one of a pointer, video, audio, a graphic, and multimedia.

17. The method of claim 2, wherein each said user identity is associated with a respective particular user's stored access rights, which determine whether the corresponding said user identity is censored from receiving, in the communications, data presenting at least one of a pointer, video, audio, a graphic, and multimedia.

18. The method of claim 1, wherein the determining whether the first user identity is censored includes determining that the first user identity is censored from the data presenting the video.

19. The method of claim 18, wherein the computer system provides access via any of two client software alternatives, wherein both of the client software alternatives allow respective user identities to be recognized and allow at least some of the participator computers to form at least one group in which members can send communications and receive communications.

20. The method of claim 18, further including:
 determining whether the first user identity is censored from sending in the communications data presenting at least one of a pointer, video, a graphic, and multimedia;

23

facilitating sending the communications that are not censored from the sending, from the first participator computer to the second participator computer, wherein the sending is in real time and via the Internet network; and if the first user identity is censored from the sending, not allowing the data that is censored to be sent from the first participator computer to the second participator computer.

21. The method of claim 18, further including determining whether at least one of the communications is censored based on content.

22. The method of claim 21, further including determining a user age corresponding to each of the user identities.

23. The method of claim 18, wherein the determining whether the first user identity is censored includes determining whether a parameter corresponding to the first user identity has been determined by an other of the user identities.

24. The method of claim 23, wherein each said user identity is associated with a respective particular user's stored access rights, which determine whether the corresponding said user identity is censored from receiving, in the communications, data presenting at least one of a pointer, video, audio, a graphic, and multimedia.

25. The method of claim 18, wherein the determining whether the first user identity and the second user identity are able to form a group includes determining from access rights stored by user in the database that neither of the user identities is censored.

26. The method of claim 18, further including determining a user age corresponding to each of the user identities.

27. The method of claim 1, wherein the determining whether the first user identity is censored includes determining that the first user identity is censored from the data presenting the audio.

28. The method of claim 27, wherein the computer system provides access via any of two client software alternatives, wherein both of the client software alternatives allow respective user identities to be recognized and allow at least some of the participator computers to form at least one group in which members can send communications and receive communications.

29. The method of claim 27, further including: determining whether the first user identity is censored from sending in the communications data presenting at least one of a pointer, video, a graphic, and multimedia; facilitating sending the communications that are not censored from the sending, from the first participator computer to the second participator computer, wherein the sending is in real time and via the Internet network; and if the first user identity is censored from the sending, not allowing the data that is censored to be sent from the first participator computer to the second participator computer.

30. The method of claim 27, further including determining whether at least one of the communications is censored based on content.

31. The method of claim 30, further including determining a user age corresponding to each of the user identities.

32. The method of claim 27, wherein the determining whether the first user identity is censored includes determining whether a parameter corresponding to the first user identity has been determined by an other of the user identities.

33. The method of claim 27, wherein the determining whether the first user identity and the second user identity are able to form a group includes determining from access rights stored by user in the database that neither of the user identities is censored.

24

34. The method of claim 27, further including determining a user age corresponding to each of the user identities.

35. The method of claim 1, wherein the determining whether the first user identity is censored includes determining that the first user identity is censored from the data presenting the graphic.

36. The method of claim 35, wherein the computer system provides access via any of two client software alternatives, wherein both of the client software alternatives allow respective user identities to be recognized and allow at least some of the participator computers to form at least one group in which members can send communications and receive communications.

37. The method of claim 35, further including: determining whether the first user identity is censored from sending in the communications data presenting at least one of a pointer, video, a graphic, and multimedia; facilitating sending the communications that are not censored from the sending, from the first participator computer to the second participator computer, wherein the sending is in real time and via the Internet network; and if the first user identity is censored from the sending, not allowing the data that is censored to be sent from the first participator computer to the second participator computer.

38. The method of claim 35, further including determining whether at least one of the communications is censored based on content.

39. The method of claim 38, further including determining a user age corresponding to each of the user identities.

40. The method of claim 35, wherein the determining whether the first user identity is censored includes determining whether a parameter corresponding to the first user identity has been determined by an other of the user identities.

41. The method of claim 35, wherein the determining whether the first user identity and the second user identity are able to form a group includes determining from access rights stored by user in the database that neither of the user identities is censored.

42. The method of claim 35, further including determining a user age corresponding to each of the user identities.

43. The method of claim 1, wherein the determining whether the first user identity is censored includes determining that the first user identity is censored from the data presenting the multimedia.

44. The method of claim 43, wherein the computer system provides access via any of two client software alternatives, wherein both of the client software alternatives allow respective user identities to be recognized and allow at least some of the participator computers to form at least one group in which members can send communications and receive communications.

45. The method of claim 43, further including: determining whether the first user identity is censored from sending in the communications data presenting at least one of a pointer, video, a graphic, and multimedia; facilitating sending the communications that are not censored from the sending, from the first participator computer to the second participator computer, wherein the sending is in real time and via the Internet network; and if the first user identity is censored from the sending, not allowing the data that is censored to be sent from the first participator computer to the second participator computer.

46. The method of claim 43, further including determining whether at least one of the communications is censored based on content.

25

47. The method of claim 46, further including determining a user age corresponding to each of the user identities.

48. The method of claim 43, wherein the determining whether the first user identity is censored includes determining whether a parameter corresponding to the first user identity has been determined by an other of the user identities.

49. The method of claim 43, wherein the determining whether the first user identity and the second user identity are able to form a group includes determining from access rights stored by user in the database that neither of the user identities is censored.

50. The method of claim 43, further including determining a user age corresponding to each of the user identities.

51. The method of claim 1, wherein the determining whether the first user identity is censored includes determining that the first user identity is censored from the data presenting the pointer and the video.

52. The method of claim 51, wherein the computer system provides access via any of two client software alternatives, wherein both of the client software alternatives allow respective user identities to be recognized and allow at least some of the participator computers to form at least one group in which members can send communications and receive communications.

53. The method of claim 52, wherein each said user identity is associated with a respective particular user's stored access rights, which determine whether the corresponding said user identity is censored from receiving, in the communications, data presenting at least one of a pointer, video, audio, a graphic, and multimedia.

54. The method of claim 51, further including:

determining whether the first user identity is censored from sending in the communications data presenting at least one of a pointer, video, a graphic, and multimedia;

facilitating sending the communications that are not censored from the sending, from the first participator computer to the second participator computer, wherein the sending is in real time and via the Internet network; and if the first user identity is censored from the sending, not allowing the data that is censored to be sent from the first participator computer to the second participator computer.

55. The method of claim 54, wherein each said user identity is associated with a respective particular user's stored access rights, which determine whether the corresponding said user identity is censored from receiving, in the communications, data presenting at least one of a pointer, video, audio, a graphic, and multimedia.

56. The method of claim 51, further including determining whether at least one of the communications is censored based on content.

57. The method of claim 56, wherein each said user identity is associated with a respective particular user's stored access rights, which determine whether the corresponding said user identity is censored from receiving, in the communications, data presenting at least one of a pointer, video, audio, a graphic, and multimedia.

58. The method of claim 51, wherein the determining whether the first user identity is censored includes determining whether a parameter corresponding to the first user identity has been determined by an other of the user identities.

59. The method of claim 58, wherein each said user identity is associated with a respective particular user's stored access rights, which determine whether the corresponding said user identity is censored from receiving, in the communications, data presenting at least one of a pointer, video, audio, a graphic, and multimedia.

26

60. The method of claim 51, wherein the determining whether the first user identity and the second user identity are able to form a group includes determining from access rights stored by user in the database that neither of the user identities is censored.

61. The method of claim 60, wherein each said user identity is associated with a respective particular user's stored access rights, which determine whether the corresponding said user identity is censored from receiving, in the communications, data presenting at least one of a pointer, video, audio, a graphic, and multimedia.

62. The method of claim 51, further including determining a user age corresponding to each of the user identities.

63. The method of claim 62, wherein each said user identity is associated with a respective particular user's stored access rights, which determine whether the corresponding said user identity is censored from receiving, in the communications, data presenting at least one of a pointer, video, audio, a graphic, and multimedia.

64. The method of claim 51, wherein each said user identity is associated with a respective particular user's stored access rights, which determine whether the corresponding said user identity is censored from receiving, in the communications, data presenting at least one of a pointer, video, audio, a graphic, and multimedia.

65. The method of claim 1, wherein the determining whether the first user identity is censored includes determining that the first user identity is censored from the data presenting the pointer and the audio.

66. The method of claim 65, wherein the computer system provides access via any of two client software alternatives, wherein both of the client software alternatives allow respective user identities to be recognized and allow at least some of the participator computers to form at least one group in which members can send communications and receive communications.

67. The method of claim 66, wherein each said user identity is associated with a respective particular user's stored access rights, which determine whether the corresponding said user identity is censored from receiving, in the communications, data presenting at least one of a pointer, video, audio, a graphic, and multimedia.

68. The method of claim 65, further including:

determining whether the first user identity is censored from sending in the communications data presenting at least one of a pointer, video, a graphic, and multimedia;

facilitating sending the communications that are not censored from the sending, from the first participator computer to the second participator computer, wherein the sending is in real time and via the Internet network; and if the first user identity is censored from the sending, not allowing the data that is censored to be sent from the first participator computer to the second participator computer.

69. The method of claim 68, wherein each said user identity is associated with a respective particular user's stored access rights, which determine whether the corresponding said user identity is censored from receiving, in the communications, data presenting at least one of a pointer, video, audio, a graphic, and multimedia.

70. The method of claim 65, further including determining whether at least one of the communications is censored based on content.

71. The method of claim 70, wherein each said user identity is associated with a respective particular user's stored access rights, which determine whether the corresponding said user

27

identity is censored from receiving, in the communications, data presenting at least one of a pointer, video, audio, a graphic, and multimedia.

72. The method of claim 65, wherein the determining whether the first user identity is censored includes determining whether a parameter corresponding to the first user identity has been determined by an other of the user identities.

73. The method of claim 72, wherein each said user identity is associated with a respective particular user's stored access rights, which determine whether the corresponding said user identity is censored from receiving, in the communications, data presenting at least one of a pointer, video, audio, a graphic, and multimedia.

74. The method of claim 65, wherein the determining whether the first user identity and the second user identity are able to form a group includes determining from access rights stored by user in the database that neither of the user identities is censored.

75. The method of claim 74, wherein each said user identity is associated with a respective particular user's stored access rights, which determine whether the corresponding said user identity is censored from receiving, in the communications, data presenting at least one of a pointer, video, audio, a graphic, and multimedia.

76. The method of claim 65, further including determining a user age corresponding to each of the user identities.

77. The method of claim 76, wherein each said user identity is associated with a respective particular user's stored access rights, which determine whether the corresponding said user identity is censored from receiving, in the communications, data presenting at least one of a pointer, video, audio, a graphic, and multimedia.

78. The method of claim 65, wherein each said user identity is associated with a respective particular user's stored access rights, which determine whether the corresponding said user identity is censored from receiving, in the communications, data presenting at least one of a pointer, video, audio, a graphic, and multimedia.

79. The method of claim 1, wherein the determining whether the first user identity is censored includes determining that the first user identity is censored from the data presenting the pointer and the graphic.

80. The method of claim 79, wherein the computer system provides access via any of two client software alternatives, wherein both of the client software alternatives allow respective user identities to be recognized and allow at least some of the participator computers to form at least one group in which members can send communications and receive communications.

81. The method of claim 80, wherein each said user identity is associated with a respective particular user's stored access rights, which determine whether the corresponding said user identity is censored from receiving, in the communications, data presenting at least one of a pointer, video, audio, a graphic, and multimedia.

82. The method of claim 79, further including:

determining whether the first user identity is censored from sending in the communications data presenting at least one of a pointer, video, a graphic, and multimedia;

facilitating sending the communications that are not censored from the sending, from the first participator computer to the second participator computer, wherein the sending is in real time and via the Internet network; and if the first user identity is censored from the sending, not allowing the data that is censored to be sent from the first participator computer to the second participator computer.

28

83. The method of claim 82, wherein each said user identity is associated with a respective particular user's stored access rights, which determine whether the corresponding said user identity is censored from receiving, in the communications, data presenting at least one of a pointer, video, audio, a graphic, and multimedia.

84. The method of claim 79, further including determining whether at least one of the communications is censored based on content.

85. The method of claim 84, wherein each said user identity is associated with a respective particular user's stored access rights, which determine whether the corresponding said user identity is censored from receiving, in the communications, data presenting at least one of a pointer, video, audio, a graphic, and multimedia.

86. The method of claim 79, wherein the determining whether the first user identity is censored includes determining whether a parameter corresponding to the first user identity has been determined by an other of the user identities.

87. The method of claim 86 wherein each said user identity is associated with a respective particular user's stored access rights, which determine whether the corresponding said user identity is censored from receiving, in the communications, data presenting at least one of a pointer, video, audio, a graphic, and multimedia.

88. The method of claim 79, wherein the determining whether the first user identity and the second user identity are able to form a group includes determining from access rights stored by user in the database that neither of the user identities is censored.

89. The method of claim 88, wherein each said user identity is associated with a respective particular user's stored access rights, which determine whether the corresponding said user identity is censored from receiving, in the communications, data presenting at least one of a pointer, video, audio, a graphic, and multimedia.

90. The method of claim 79, further including determining a user age corresponding to each of the user identities.

91. The method of claim 90, wherein each said user identity is associated with a respective particular user's stored access rights, which determine whether the corresponding said user identity is censored from receiving, in the communications, data presenting at least one of a pointer, video, audio, a graphic, and multimedia.

92. The method of claim 79, wherein each said user identity is associated with a respective particular user's stored access rights, which determine whether the corresponding said user identity is censored from receiving, in the communications, data presenting at least one of a pointer, video, audio, a graphic, and multimedia.

93. The method of claim 1, wherein the determining whether the first user identity is censored includes determining that the first user identity is censored from the data presenting the video and the audio.

94. The method of claim 93, wherein the computer system provides access via any of two client software alternatives, wherein both of the client software alternatives allow respective user identities to be recognized and allow at least some of the participator computers to form at least one group in which members can send communications and receive communications.

95. The method of claim 93, further including:

determining whether the first user identity is censored from sending in the communications data presenting at least one of a pointer, video, a graphic, and multimedia;

facilitating sending the communications that are not censored from the sending, from the first participator com-

29

puter to the second participator computer, wherein the sending is in real time and via the Internet network; and if the first user identity is censored from the sending, not allowing the data that is censored to be sent from the first participator computer to the second participator computer.

96. The method of claim 93, further including determining whether at least one of the communications is censored based on content.

97. The method of claim 93, wherein the determining whether the first user identity is censored includes determining whether a parameter corresponding to the first user identity has been determined by an other of the user identities.

98. The method of claim 93, wherein the determining whether the first user identity and the second user identity are able to form a group includes determining from access rights stored by user in the database that neither of the user identities is censored.

99. The method of claim 93, further including determining a user age corresponding to each of the user identities.

100. The method of claim 1, wherein the determining whether the first user identity is censored includes determining that the first user identity is censored from the data presenting the video and the graphic.

101. The method of claim 100, wherein the computer system provides access via any of two client software alternatives, wherein both of the client software alternatives allow respective user identities to be recognized and allow at least some of the participator computers to form at least one group in which members can send communications and receive communications.

102. The method of claim 100, further including: determining whether the first user identity is censored from sending in the communications data presenting at least one of a pointer, video, a graphic, and multimedia; facilitating sending the communications that are not censored from the sending, from the first participator computer to the second participator computer, wherein the sending is in real time and via the Internet network; and if the first user identity is censored from the sending, not allowing the data that is censored to be sent from the first participator computer to the second participator computer.

103. The method of claim 100, further including determining whether at least one of the communications is censored based on content.

104. The method of claim 100, wherein the determining whether the first user identity is censored includes determining whether a parameter corresponding to the first user identity has been determined by an other of the user identities.

105. The method of claim 104, wherein each said user identity is associated with a respective particular user's stored access rights, which determine whether the corresponding said user identity is censored from receiving, in the communications, data presenting at least one of a pointer, video, audio, a graphic, and multimedia.

106. The method of claim 100, wherein the determining whether the first user identity and the second user identity are able to form a group includes determining from access rights stored by user in the database that neither of the user identities is censored.

107. The method of claim 100, further including determining a user age corresponding to each of the user identities.

108. The method of claim 1, wherein the determining whether the first user identity is censored includes determining that the first user identity is censored from the data presenting the audio and the graphic.

30

109. The method of claim 108, wherein the computer system provides access via any of two client software alternatives, wherein both of the client software alternatives allow respective user identities to be recognized and allow at least some of the participator computers to form at least one group in which members can send communications and receive communications.

110. The method of claim 108, further including: determining whether the first user identity is censored from sending in the communications data presenting at least one of a pointer, video, a graphic, and multimedia; facilitating sending the communications that are not censored from the sending, from the first participator computer to the second participator computer, wherein the sending is in real time and via the Internet network; and if the first user identity is censored from the sending, not allowing the data that is censored to be sent from the first participator computer to the second participator computer.

111. The method of claim 108, further including determining whether at least one of the communications is censored based on content.

112. The method of claim 108, wherein the determining whether the first user identity and the second user identity are able to form a group includes determining from access rights stored by user in the database that neither of the user identities is censored.

113. The method of claim 108, further including determining a user age corresponding to each of the user identities.

114. The method of claim 1, wherein the determining whether the first user identity is censored includes determining that the first user identity is censored from the data presenting the pointer and the video and the audio.

115. The method of claim 114, wherein the computer system provides access via any of two client software alternatives, wherein both of the client software alternatives allow respective user identities to be recognized and allow at least some of the participator computers to form at least one group in which members can send communications and receive communications.

116. The method of claim 115, wherein each said user identity is associated with a respective particular user's stored access rights, which determine whether the corresponding said user identity is censored from receiving, in the communications, data presenting at least one of a pointer, video, audio, a graphic, and multimedia.

117. The method of claim 114, further including: determining whether the first user identity is censored from sending in the communications data presenting at least one of a pointer, video, a graphic, and multimedia; facilitating sending the communications that are not censored from the sending, from the first participator computer to the second participator computer, wherein the sending is in real time and via the Internet network; and if the first user identity is censored from the sending, not allowing the data that is censored to be sent from the first participator computer to the second participator computer.

118. The method of claim 117, wherein each said user identity is associated with a respective particular user's stored and rights, which determine whether the corresponding said user identity is censored from receiving, in the communications, data presenting at least one of a pointer, video, audio, a graphic, and multimedia.

119. The method of claim 114, further including determining whether at least one of the communications is censored based on content.

31

120. The method of claim **119**, wherein each said user identity is associated with a respective particular user's stored access rights, which determine whether the corresponding said user identity is censored from receiving, in the communications, data presenting at least one of a pointer, video, audio, a graphic, and multimedia.

121. The method of claim **114**, wherein the determining whether the first user identity and the second user identity are able to form a group includes determining from access rights stored by user in the database that neither of the user identities is censored.

122. The method of claim **121**, wherein each said user identity is associated with a respective particular user's stored access rights, which determine whether the corresponding said user identity is censored from receiving, in the communications, data presenting at least one of a pointer, video, audio, a graphic, and multimedia.

123. The method of claim **114**, further including determining a user age corresponding to each of the user identities.

124. The method of claim **123**, wherein each said user identity is associated with a respective particular user's stored access rights, which determine whether the corresponding said user identity is censored from receiving, in the communications, data presenting at least one of a pointer, video, audio, a graphic, and multimedia.

125. The method of claim **114**, wherein each said user identity is associated with a respective particular user's stored access rights, which determine whether the corresponding said user identity is censored from receiving, in the communications, data presenting at least one of a pointer, video, audio, a graphic, and multimedia.

126. The method of claim **1**, wherein the determining whether the first user identity is censored includes determining that the first user identity is censored from the data presenting the pointer and the video and the graphic.

127. The method of claim **126**, wherein the computer system provides access via any of two client software alternatives, wherein both of the client software alternatives allow respective user identities to be recognized and allow at least some of the participator computers to form at least one group in which members can send communications and receive communications.

128. The method of claim **127**, wherein each said user identity is associated with a respective particular user's stored access rights, which determine whether the corresponding said user identity is censored from receiving, in the communications, data presenting at least one of a pointer, video, audio, a graphic, and multimedia.

129. The method of claim **126**, further including:
determining whether the first user identity is censored from sending in the communications data presenting at least one of a pointer, video, a graphic, and multimedia;
facilitating sending the communications that are not censored from the sending, from the first participator computer to the second participator computer, wherein the sending is in real time and via the Internet network; and
if the first user identity is censored from the sending, not allowing the data that is censored to be sent from the first participator computer to the second participator computer.

130. The method of claim **129**, wherein each said user identity is associated with a respective particular user's stored access rights, which determine whether the corresponding said user identity is censored from receiving, in the communications, data presenting at least one of a pointer, video, audio, a graphic, and multimedia.

32

131. The method of claim **126**, further including determining whether at least one of the communications is censored based on content.

132. The method of claim **131**, wherein each said user identity is associated with a respective particular user's stored access rights, which determine whether the corresponding said user identity is censored from receiving, in the communications, data presenting at least one of a pointer, video, audio, a graphic, and multimedia.

133. The method of claim **126**, wherein the determining whether the first user identity and the second user identity are able to form a group includes determining from access rights stored by user in the database that neither of the user identities is censored.

134. The method of claim **133**, wherein each said user identity is associated with a respective particular user's stored access rights, which determine whether the corresponding said user identity is censored from receiving, in the communications, data presenting at least one of a pointer, video, audio, a graphic, and multimedia.

135. The method of claim **126**, further including determining a user age corresponding to each of the user identities.

136. The method of claim **135**, wherein each said user identity is associated with a respective particular user's stored access rights, which determine whether the corresponding said user identity is censored from receiving, in the communications, data presenting at least one of a pointer, video, audio, a graphic, and multimedia.

137. The method of claim **126**, wherein each said user identity is associated with a respective particular user's stored access rights, which determine whether the corresponding said user identity is censored from receiving, in the communications, data presenting at least one of a pointer, video, audio, a graphic, and multimedia.

138. The method of claim **1**, wherein the determining whether the first user identity is censored includes determining that the first user identity is censored from the data presenting the a pointer and the audio and the graphic.

139. The method of claim **138**, wherein the computer system provides access via any of two client software alternatives, wherein both of the client software alternatives allow respective user identities to be recognized and allow at least some of the participator computers to form at least one group in which members can send communications and receive communications.

140. The method of claim **139**, wherein each said user identity is associated with a respective particular user's stored access rights, which determine whether the corresponding said user identity is censored from receiving, in the communications, data presenting at least one of a pointer, video, audio, a graphic, and multimedia.

141. The method of claim **138**, further including:
determining whether the first user identity is censored from sending in the communications data presenting at least one of a pointer, video, a graphic, and multimedia;
facilitating sending the communications that are not censored from the sending, from the first participator computer to the second participator computer, wherein the sending is in real time and via the Internet network; and
if the first user identity is censored from the sending, not allowing the data that is censored to be sent from the first participator computer to the second participator computer.

142. The method of claim **141**, wherein each said user identity is associated with a respective particular user's stored access rights, which determine whether the corresponding said user identity is censored from receiving, in the commu-

33

nications, data presenting at least one of a pointer, video, audio, a graphic, and multimedia.

143. The method of claim **138**, further including determining whether at least one of the communications is censored based on content.

144. The method of claim **143**, wherein each said user identity is associated with a respective particular user's stored access rights, which determine whether the corresponding said user identity is censored from receiving, in the communications, data presenting at least one of a pointer, video, audio, a graphic, and multimedia.

145. The method of claim **138**, wherein the determining whether the first user identity and the second user identity are able to form a group includes determining from access rights stored by user in the database that neither of the user identities is censored.

146. The method of claim **145**, wherein each said user identity is associated with a respective particular user's stored access rights, which determine whether the corresponding said user identity is censored from receiving, in the communications, data presenting at least one of a pointer, video, audio, a graphic, and multimedia.

147. The method of claim **138**, further including determining a user age corresponding to each of the user identities.

148. The method of claim **147**, wherein each said user identity is associated with a respective particular user's stored access rights, which determine whether the corresponding said user identity is censored from receiving, in the communications, data presenting at least one of a pointer, video, audio, a graphic, and multimedia.

149. The method of claim **138**, wherein each said user identity is associated with a respective particular user's stored access rights, which determine whether the corresponding said user identity is censored from receiving, in the communications, data presenting at least one of a pointer, video, audio, a graphic, and multimedia.

150. The method of claim **1**, wherein the determining whether the first user identity is censored includes determining that the first user identity is censored from the data presenting the video and the audio and the graphic.

151. The method of claim **150**, wherein the computer system provides access via any of two client software alternatives, wherein both of the client software alternatives allow respective user identities to be recognized and allow at least some of the participator computers to form at least one group in which members can send communications and receive communications.

152. The method of claim **150**, further including:
determining whether the first user identity is censored from sending in the communications data presenting at least one of a pointer, video, a graphic, and multimedia;
facilitating sending the communications that are not censored from the sending, from the first participator computer to the second participator computer, wherein the sending is in real time and via the Internet network; and
if the first user identity is censored from the sending, not allowing the data that is censored to be sent from the first participator computer to the second participator computer.

153. The method of claim **150**, further including determining whether at least one of the communications is censored based on content.

154. The method of claim **150**, wherein the determining whether the first user identity and the second user identity are able to form a group includes determining from access rights stored by user in the database that neither of the user identities is censored.

34

155. The method of claim **150**, further including determining a user age corresponding to each of the user identities.

156. The method of claim **1**, wherein the determining whether the first user identity is censored includes determining that the first user identity is censored from the data presenting the pointer and the video and the audio and the graphic.

157. The method of claim **156**, wherein the computer system provides access via any of two client software alternatives, wherein both of the client software alternatives allow respective user identities to be recognized and allow at least some of the participator computers to form at least one group in which members can send communications and receive communications.

158. The method of claim **157**, wherein each said user identity is associated with a respective particular user's stored access rights, which determine whether the corresponding said user identity is censored from receiving, in the communications, data presenting at least one of a pointer, video, audio, a graphic, and multimedia.

159. The method of claim **157**, further including:
determining whether the first user identity is censored from sending in the communications data presenting at least one of a pointer, video, a graphic, and multimedia;
facilitating sending the communications that are not censored from the sending, from the first participator computer to the second participator computer, wherein the sending is in real time and via the Internet network; and
if the first user identity is censored from the sending, not allowing the data that is censored to be sent from the first participator computer to the second participator computer.

160. The method of claim **159**, wherein each said user identity is associated with a respective particular user's stored access rights, which determine whether the corresponding said user identity is censored from receiving, in the communications, data presenting at least one of a pointer, video, audio, a graphic, and multimedia.

161. The method of claim **157**, further including determining whether at least one of the communications is censored based on content.

162. The method of claim **161**, wherein each said user identity is associated with a respective particular user's stored access rights, which determine whether the corresponding said user identity is censored from receiving, in the communications, data presenting at least one of a pointer, video, audio, a graphic, and multimedia.

163. The method of claim **157**, wherein the determining whether the first user identity and the second user identity are able to form a group includes determining from access rights stored by user in the database that neither of the user identities is censored.

164. The method of claim **163**, wherein each said user identity is associated with a respective particular user's stored access rights, which determine whether the corresponding said user identity is censored from receiving, in the communications, data presenting at least one of a pointer, video, audio, a graphic, and multimedia.

165. The method of claim **157**, further including determining a user age corresponding to each of the user identities.

166. The method of claim **165**, wherein each said user identity is associated with a respective particular user's stored access rights, which determine whether the corresponding said user identity is censored from receiving, in the communications, data presenting at least one of a pointer, video, audio, a graphic, and multimedia.

35

167. The method of claim 157, wherein each said user identity is associated with a respective particular user's stored access rights, which determine whether the corresponding said user identity is censored from receiving, in the communications, data presenting at least one of a pointer, video, audio, a graphic, and multimedia.

168. The method of claim 1, wherein the computer system provides access via any of two client software alternatives, wherein both of the client software alternatives allow respective user identities to be recognized and allow at least some of the participator computers to form at least one group in which members can send communications and receive communications.

169. The method of claim 168, wherein each said user identity is associated with a respective particular user's stored access rights, which determine whether the corresponding said user identity is censored from receiving, in the communications, data presenting at least one of a pointer, video, audio, a graphic, and multimedia.

170. The method of claim 1, further including:

determining whether the first user identity is censored from sending in the communications data presenting at least one of a pointer, video, a graphic, and multimedia;

facilitating sending the communications that are not censored from the sending, from the first participator computer to the second participator computer, wherein the sending is in real time and via the Internet network; and if the first user identity is censored from the sending, not allowing the data that is censored to be sent from the first participator computer to the second participator computer.

171. The method of claim 170, wherein each said user identity is associated with a respective particular user's stored access rights, which determine whether the corresponding said user identity is censored from receiving, in the communications, data presenting at least one of a pointer, video, audio, a graphic, and multimedia.

172. The method of claim 1, further including determining whether at least one of the communications is censored based on content.

173. The method of claim 172, further including determining a user age corresponding to each of the user identities.

174. The method of claim 173, wherein each said user identity is associated with a respective particular user's stored access rights, which determine whether the corresponding said user identity is censored from receiving, in the communications, data presenting at least one of a pointer, video, audio, a graphic, and multimedia.

175. The method of claim 172, wherein each said user identity is associated with a respective particular user's stored access rights, which determine whether the corresponding said user identity is censored from receiving, in the communications, data presenting at least one of a pointer, video, audio, a graphic, and multimedia.

176. The method of claim 1, wherein the determining whether the first user identity is censored includes determining whether a parameter corresponding to the first user identity has been determined by an other of the user identities.

177. The method of claim 176, wherein each said user identity is associated with a respective particular user's stored access rights, which determine whether the corresponding said user identity is censored from receiving, in the communications, data presenting at least one of a pointer, video, audio, a graphic, and multimedia.

178. The method of claim 1, wherein the determining whether the first user identity and the second user identity are

36

able to form a group includes determining from access rights stored by user in the database that neither of the user identities is censored.

179. The method of claim 178, wherein each said user identity is associated with a respective particular user's stored access rights, which determine whether the corresponding said user identity is censored from receiving, in the communications, data presenting at least one of a pointer, video, audio, a graphic, and multimedia.

180. The method of claim 1, further including determining a user age corresponding to each of the user identities.

181. The method of claim 180, wherein each said user identity is associated with a respective particular user's stored access rights, which determine whether the corresponding said user identity is censored from receiving, in the communications, data presenting at least one of a pointer, video, audio, a graphic, and multimedia.

182. The method of claim 1, wherein each said user identity is associated with a respective particular user's stored access rights, which determine whether the corresponding said user identity is censored from receiving, in the communications, data presenting at least one of a pointer, video, audio, a graphic, and multimedia.

183. The method of claim 1, wherein receiving the communications includes causing presentation of some of the communications by one of the plurality of participator computers in the group.

184. The method of claim 1, wherein, if the first user identity is censored, not allowing the communications that include the data that is censored.

185. The method of claim 1, wherein the computer system comprises an Internet service provider computer.

186. The method of claim 1, further including: storing, for the first user identity, an authorization associated with presentation of graphical multimedia; and based on the authorization, facilitating presentation of the graphical multimedia at an output device corresponding to the second user identity.

187. The method of claim 1, further including: providing the first user identity with access to a member-associated image corresponding to the second user identity.

188. The method of claim 1, further including: determining whether the first user identity is censored from access to a member-associated image corresponding to the second user identity; if the first user identity is censored, not allowing access to the member-associated image; and if the first user identity is not censored, allowing access to the member-associated image.

189. A method of communicating via an Internet network by using a computer system including a controller computer and a database which serves as a repository of tokens for other programs to access, thereby affording information to each of a plurality of participator computers which are otherwise independent of each other, the method including:

affording some of the information to a first of the participator computers via the Internet network, responsive to an authenticated first user identity;

affording some of the information to a second of the participator computers via the Internet network, responsive to an authenticated second user identity; and

determining whether the first user identity and the second user identity are able to form a group to send and to receive real-time communications; and

determining whether the first user identity is individually censored from sending data in the communications, the

37

data presenting at least one of a pointer, video, audio, a graphic, and multimedia by determining whether a respective at least one parameter corresponding to the first user identity has been determined by an other of the user identities; and

if the user identities are able to form the group, forming the group and facilitating sending the communications that are not censored from the first participator computer to the second participator computer, wherein the sending is in real time and via the Internet network, and wherein, for the communications which are received and which present an Internet URL, facilitating handling the Internet URL via the computer system so as to find content specified by the Internet URL and presenting the content at an output device of the second participator computer, and

if the first user identity is censored from the sending of the data, not allowing sending the data that is censored from the first participator computer to the second participator computer.

190. The method of claim **189**, wherein the determining whether the first user identity is censored includes determining that the first user identity is censored from the sending of the data presenting the pointer.

191. The method of claim **190**, wherein the computer system provides access via any of two client software alternatives, wherein both of the client software alternatives allow respective user identities to be recognized and allow at least some of the participator computers to form at least one group in which members can send communications and receive communications.

192. The method of claim **191**, wherein each said user identity is associated with a respective particular user's stored access rights, which determine whether the corresponding said user identity is censored from sending, in the communications, data presenting at least one of a pointer, video, audio, a graphic, and multimedia.

193. The method of claim **190**, further including determining whether at least one of the communications is censored based on content.

194. The method of claim **193**, wherein each said user identity is associated with a respective particular user's stored access rights, which determine whether the corresponding said user identity is censored from sending, in the communications, data presenting at least one of a pointer, video, audio, a graphic, and multimedia.

195. The method of claim **190**, wherein the determining whether the first user identity and the second user identity are able to form a group includes determining from access rights stored by user in the database that neither of the user identities is censored.

196. The method of claim **195**, wherein each said user identity is associated with a respective particular user's stored access rights, which determine whether the corresponding said user identity is censored from sending, in the communications, data presenting at least one of a pointer, video, audio, a graphic, and multimedia.

197. The method of claim **190**, further including determining a user age corresponding to each of the user identities.

198. The method of claim **197**, wherein each said user identity is associated with a respective particular user's stored access rights, which determine whether the corresponding said user identity is censored from sending, in the communications, data presenting at least one of a pointer, video, audio, a graphic, and multimedia.

38

199. The method of claim **190**, wherein at least one of the communications includes data presenting a human communication of sound.

200. The method of claim **199**, wherein each said user identity is associated with a respective particular user's stored access rights, which determine whether the corresponding said user identity is censored from sending, in the communications, data presenting at least one of a pointer, video, audio, a graphic, and multimedia.

201. The method of claim **190**, wherein each said user identity is associated with a respective particular user's stored access rights, which determine whether the corresponding said user identity is censored from sending, in the communications, data presenting at least one of a pointer, video, audio, a graphic, and multimedia.

202. The method of claim **189**, wherein the determining whether the first user identity is censored includes determining that the first user identity is censored from the sending of the data presenting the video.

203. The method of claim **202**, wherein the computer system provides access via any of two client software alternatives, wherein both of the client software alternatives allow respective user identities to be recognized and allow at least some of the participator computers to form at least one group in which members can send communications and receive communications.

204. The method of claim **202**, further including determining whether at least one of the communications is censored based on content.

205. The method of claim **202**, wherein the determining whether the first user identity and the second user identity are able to form a group includes determining from access rights stored by user in the database that neither of the user identities is censored.

206. The method of claim **202**, further including determining a user age corresponding to each of the user identities.

207. The method of claim **202**, wherein at least one of the communications includes data presenting a human communication of sound.

208. The method of claim **189**, wherein the determining whether the first user identity is censored includes determining that the first user identity is censored from the sending of the data presenting the audio.

209. The method of claim **208**, wherein the computer system provides access via any of two client software alternatives, wherein both of the client software alternatives allow respective user identities to be recognized and allow at least some of the participator computers to form at least one group in which members can send communications and receive communications.

210. The method of claim **208**, further including determining whether at least one of the communications is censored based on content.

211. The method of claim **208**, wherein the determining whether the first user identity and the second user identity are able to form a group includes determining from access rights stored by user in the database that neither of the user identities is censored.

212. The method of claim **208**, further including determining a user age corresponding to each of the user identities.

213. The method of claim **208**, wherein at least one of the communications includes data presenting a human communication of sound.

214. The method of claim **189**, wherein the determining whether the first user identity is censored includes determining that the first user identity is censored from the sending of the data presenting the graphic.

215. The method of claim **214**, wherein the computer system provides access via any of two client software alternatives, wherein both of the client software alternatives allow respective user identities to be recognized and allow at least some of the participator computers to form at least one group in which members can send communications and receive communications.

216. The method of claim **214**, further including determining whether at least one of the communications is censored based on content.

217. The method of claim **214**, wherein the determining whether the first user identity and the second user identity are able to form a group includes determining from access rights stored by user in the database that neither of the user identities is censored.

218. The method of claim **214**, further including determining a user age corresponding to each of the user identities.

219. The method of claim **214**, wherein at least one of the communications includes data presenting a human communication of sound.

220. The method of claim **189**, wherein the determining whether the first user identity is censored includes determining that the first user identity is censored from the sending of the data presenting the multimedia.

221. The method of claim **220**, wherein the computer system provides access via any of two client software alternatives, wherein both of the client software alternatives allow respective user identities to be recognized and allow at least some of the participator computers to form at least one group in which members can send communications and receive communications.

222. The method of claim **220**, further including determining whether at least one of the communications is censored based on content.

223. The method of claim **220**, wherein the determining whether the first user identity and the second user identity are able to form a group includes determining from access rights stored by user in the database that neither of the user identities is censored.

224. The method of claim **220**, further including determining a user age corresponding to each of the user identities.

225. The method of claim **220**, wherein at least one of the communications includes data presenting a human communication of sound.

226. The method of claim **189**, wherein the determining whether the first user identity is censored includes determining that the first user identity is censored from the sending of the data presenting the pointer and the video.

227. The method of claim **226**, wherein the computer system provides access via any of two client software alternatives, wherein both of the client software alternatives allow respective user identities to be recognized and allow at least some of the participator computers to form at least one group in which members can send communications and receive communications.

228. The method of claim **227**, wherein each said user identity is associated with a respective particular user's stored access rights, which determine whether the corresponding said user identity is censored from sending, in the communications, data presenting at least one of a pointer, video, audio, a graphic, and multimedia.

229. The method of claim **226**, further including determining whether at least one of the communications is censored based on content.

230. The method of claim **229**, wherein each said user identity is associated with a respective particular user's stored access rights, which determine whether the corresponding

said user identity is censored from sending, in the communications, data presenting at least one of a pointer, video, audio, a graphic, and multimedia.

231. The method of claim **226**, wherein the determining whether the first user identity and the second user identity are able to form a group includes determining from access rights stored by user in the database that neither of the user identities is censored.

232. The method of claim **231** wherein each said user identity is associated with a respective particular user's stored access rights, which determine whether the corresponding said user identity is censored from sending, in the communications, data presenting at least one of a pointer, video, audio, a graphic, and multimedia.

233. The method of claim **226**, further including determining a user age corresponding to each of the user identities.

234. The method of claim **233**, wherein each said user identity is associated with a respective particular user's stored access rights, which determine whether the corresponding said user identity is censored from sending, in the communications, data presenting at least one of a pointer, video, audio, a graphic, and multimedia.

235. The method of claim **226**, wherein at least one of the communications includes data presenting a human communication of sound.

236. The method of claim **235**, wherein each said user identity is associated with a respective particular user's stored access rights, which determine whether the corresponding said user identity is censored from sending, in the communications, data presenting at least one of a pointer, video, audio, a graphic, and multimedia.

237. The method of claim **226**, wherein each said user identity is associated with a respective particular user's stored access rights, which determine whether the corresponding said user identity is censored from sending, in the communications, data presenting at least one of a pointer, video, audio, a graphic, and multimedia.

238. The method of claim **189**, wherein the determining whether the first user identity is censored includes determining that the first user identity is censored from the sending of the data presenting the pointer and the audio.

239. The method of claim **238**, wherein the computer system provides access via any of two client software alternatives, wherein both of the client software alternatives allow respective user identities to be recognized and allow at least some of the participator computers to form at least one group in which members can send communications and receive communications.

240. The method of claim **239**, wherein each said user identity is associated with a respective particular user's stored access rights, which determine whether the corresponding said user identity is censored from sending, in the communications, data presenting at least one of a pointer, video, audio, a graphic, and multimedia.

241. The method of claim **238**, further including determining whether at least one of the communications is censored based on content.

242. The method of claim **241**, wherein each said user identity is associated with a respective particular user's stored access rights, which determine whether the corresponding said user identity is censored from sending, in the communications, data presenting at least one of a pointer, video, audio, a graphic, and multimedia.

243. The method of claim **238**, wherein the determining whether the first user identity and the second user identity are

41

able to form a group includes determining from access rights stored by user in the database that neither of the user identities is censored.

244. The method of claim 243, wherein each said user identity is associated with a respective particular user's stored access rights, which determine whether the corresponding said user identity is censored from sending, in the communications, data presenting at least one of a pointer, video, audio, a graphic, and multimedia.

245. The method of claim 238, further including determining a user age corresponding to each of the user identities.

246. The method of claim 245, wherein each said user identity is associated with a respective particular user's stored access rights, which determine whether the corresponding said user identity is censored from sending, in the communications, data presenting at least one of a pointer, video, audio, a graphic, and multimedia.

247. The method of claim 238, wherein at least one of the communications includes data presenting a human communication of sound.

248. The method of claim 247, wherein each said user identity is associated with a respective particular user's stored access rights, which determine whether the corresponding said user identity is censored from sending, in the communications, data presenting at least one of a pointer, video, audio, a graphic, and multimedia.

249. The method of claim 238, wherein each said user identity is associated with a respective particular user's stored access rights, which determine whether the corresponding said user identity is censored from sending, in the communications, data presenting at least one of a pointer, video, audio, a graphic, and multimedia.

250. The method of claim 189, wherein the determining whether the first user identity is censored includes determining that the first user identity is censored from the sending of the data presenting the pointer and the graphic.

251. The method of claim 250, wherein the computer system provides access via any of two client software alternatives, wherein both of the client software alternatives allow respective user identities to be recognized and allow at least some of the participator computers to form at least one group in which members can send communications and receive communications.

252. The method of claim 251, wherein each said user identity is associated with a respective particular user's stored access rights, which determine whether the corresponding said user identity is censored from sending, in the communications, data presenting at least one of a pointer, video, audio, a graphic, and multimedia.

253. The method of claim 250, further including determining whether at least one of the communications is censored based on content.

254. The method of claim 253, wherein each said user identity is associated with a respective particular user's stored access rights, which determine whether the corresponding said user identity is censored from sending, in the communications, data presenting at least one of a pointer, video, audio, a graphic, and multimedia.

255. The method of claim 250, wherein the determining whether the first user identity and the second user identity are able to form a group includes determining from access rights stored by user in the database that neither of the user identities is censored.

256. The method of claim 255, wherein each said user identity is associated with a respective particular user's stored access rights, which determine whether the corresponding

42

said user identity is censored from sending, in the communications, data presenting at least one of a pointer, video, audio, a graphic, and multimedia.

257. The method of claim 250, further including determining a user age corresponding to each of the user identities.

258. The method of claim 257, wherein each said user identity is associated with a respective particular user's stored access rights, which determine whether the corresponding said user identity is censored from sending, in the communications, data presenting at least one of a pointer, video, audio, a graphic, and multimedia.

259. The method of claim 250, wherein at least one of the communications includes data presenting a human communication of sound.

260. The method of claim 259, wherein each said user identity is associated with a respective particular user's stored access rights, which determine whether the corresponding said user identity is censored from sending, in the communications, data presenting at least one of a pointer, video, audio, a graphic, and multimedia.

261. The method of claim 250, wherein each said user identity is associated with a respective particular user's stored access rights, which determine whether the corresponding said user identity is censored from sending, in the communications, data presenting at least one of a pointer, video, audio, a graphic, and multimedia.

262. The method of claim 189, wherein the determining whether the first user identity is censored includes determining that the first user identity is censored from the sending of the data presenting the video and the audio.

263. The method of claim 262, wherein the computer system provides access via any of two client software alternatives, wherein both of the client software alternatives allow respective user identities to be recognized and allow at least some of the participator computers to form at least one group in which members can send communications and receive communications.

264. The method of claim 262, further including determining whether at least one of the communications is censored based on content.

265. The method of claim 262, wherein the determining whether the first user identity and the second user identity are able to form a group includes determining from access rights stored by user in the database that neither of the user identities is censored.

266. The method of claim 262, further including determining a user age corresponding to each of the user identities.

267. The method of claim 262, wherein at least one of the communications includes data presenting a human communication of sound.

268. The method of claim 189, wherein the determining whether the first user identity is censored includes determining that the first user identity is censored from the sending of the data presenting the video and the graphic.

269. The method of claim 268, wherein the computer system provides access via any of two client software alternatives, wherein both of the client software alternatives allow respective user identities to be recognized and allow at least some of the participator computers to form at least one group in which members can send communications and receive communications.

270. The method of claim 268, further including determining whether at least one of the communications is censored based on content.

271. The method of claim 268, wherein the determining whether the first user identity and the second user identity are

43

able to form a group includes determining from access rights stored by user in the database that neither of the user identities is censored.

272. The method of claim 268, further including determining a user age corresponding to each of the user identities.

273. The method of claim 268, wherein at least one of the communications includes data presenting a human communication of sound.

274. The method of claim 189, wherein the determining whether the first user identity is censored includes determining that the first user identity is censored from the sending of the data presenting the audio and the graphic.

275. The method of claim 274, wherein the computer system provides access via any of two client software alternatives, wherein both of the client software alternatives allow respective user identities to be recognized and allow at least some of the participator computers to form at least one group in which members can send communications and receive communications.

276. The method of claim 274, further including determining whether at least one of the communications is censored based on content.

277. The method of claim 274 wherein the determining whether the first user identity and the second user identity are able to form a group includes determining from access rights stored by user in the database that neither of the user identities is censored.

278. The method of claim 274, further including determining a user age corresponding to each of the user identities.

279. The method of claim 274, wherein at least one of the communications includes data presenting a human communication of sound.

280. The method of claim 189, wherein the determining whether the first user identity is censored includes determining that the first user identity is censored from the sending of the data presenting the pointer and the video and the audio.

281. The method of claim 280, wherein the computer system provides access via any of two client software alternatives, wherein both of the client software alternatives allow respective user identities to be recognized and allow at least some of the participator computers to form at least one group in which members can send communications and receive communications.

282. The method of claim 281, wherein each said user identity is associated with a respective particular user's stored access rights, which determine whether the corresponding said user identity is censored from sending, in the communications, data presenting at least one of a pointer, video, audio, a graphic, and multimedia.

283. The method of claim 280, further including determining whether at least one of the communications is censored based on content.

284. The method of claim 283, wherein each said user identity is associated with a respective particular user's stored access rights, which determine whether the corresponding said user identity is censored from sending, in the communications, data presenting at least one of a pointer, video, audio, a graphic, and multimedia.

285. The method of claim 280, wherein the determining whether the first user identity and the second user identity are able to form a group includes determining from access rights stored by user in the database that neither of the user identities is censored.

286. The method of claim 285, wherein each said user identity is associated with a respective particular user's stored access rights, which determine whether the corresponding

44

said user identity is censored from sending, in the communications, data presenting at least one of a pointer, video, audio, a graphic, and multimedia.

287. The method of claim 280, further including determining a user age corresponding to each of the user identities.

288. The method of claim 287, wherein each said user identity is associated with a respective particular user's stored access rights, which determine whether the corresponding said user identity is censored from sending, in the communications, data presenting at least one of a pointer, video, audio, a graphic, and multimedia.

289. The method of claim 280, wherein at least one of the communications includes data presenting a human communication of sound.

290. The method of claim 289, wherein each said user identity is associated with a respective particular user's stored access rights, which determine whether the corresponding said user identity is censored from sending, in the communications, data presenting at least one of a pointer, video, audio, a graphic, and multimedia.

291. The method of claim 280, wherein each said user identity is associated with a respective particular user's stored access rights, which determine whether the corresponding said user identity is censored from sending, in the communications, data presenting at least one of a pointer, video, audio, a graphic, and multimedia.

292. The method of claim 189, wherein the determining whether the first user identity is censored includes determining that the first user identity is censored from the sending of the data presenting the pointer and the video and the graphic.

293. The method of claim 292, wherein the computer system provides access via any of two client software alternatives, wherein both of the client software alternatives allow respective user identities to be recognized and allow at least some of the participator computers to form at least one group in which members can send communications and receive communications.

294. The method of claim 293, wherein each said user identity is associated with a respective particular user's stored access rights, which determine whether the corresponding said user identity is censored from sending, in the communications, data presenting at least one of a pointer, video, audio, a graphic, and multimedia.

295. The method of claim 292, further including determining whether at least one of the communications is censored based on content.

296. The method of claim 295, wherein each said user identity is associated with a respective particular user's stored access rights, which determine whether the corresponding said user identity is censored from sending, in the communications, data presenting at least one of a pointer, video, audio, a graphic, and multimedia.

297. The method of claim 292, wherein the determining whether the first user identity and the second user identity are able to form a group includes determining from access rights stored by user in the database that neither of the user identities is censored.

298. The method of claim 297, wherein each said user identity is associated with a respective particular user's stored access rights, which determine whether the corresponding said user identity is censored from sending, in the communications, data presenting at least one of a pointer, video, audio, a graphic, and multimedia.

299. The method of claim 292, further including determining a user age corresponding to each of the user identities.

300. The method of claim 299, wherein each said user identity is associated with a respective particular user's stored

45

access rights, which determine whether the corresponding said user identity is censored from sending, in the communications, data presenting at least one of a pointer, video, audio, a graphic, and multimedia.

301. The method of claim **292**, wherein at least one of the communications includes data presenting a human communication of sound.

302. The method of claim **301**, wherein each said user identity is associated with a respective particular user's stored access rights, which determine whether the corresponding said user identity is censored from sending, in the communications, data presenting at least one of a pointer, video, audio, a graphic, and multimedia.

303. The method of claim **292**, wherein each said user identity is associated with a respective particular user's stored access rights, which determine whether the corresponding said user identity is censored from sending, in the communications, data presenting at least one of a pointer, video, audio, a graphic, and multimedia.

304. The method of claim **189**, wherein the determining whether the first user identity is censored includes determining that the first user identity is censored from the sending of the data presenting the pointer and the audio and the graphic.

305. The method of claim **304**, wherein the computer system provides access via any of two client software alternatives, wherein both of the client software alternatives allow respective user identities to be recognized and allow at least some of the participator computers to form at least one group in which members can send communications and receive communications.

306. The method of claim **305**, wherein each said user identity is associated with a respective particular user's stored access rights, which determine whether the corresponding said user identity is censored from sending, in the communications, data presenting at least one of a pointer, video, audio, a graphic, and multimedia.

307. The method of claim **304**, further including determining whether at least one of the communications is censored based on content.

308. The method of claim **307**, wherein each said user identity is associated with a respective particular user's stored access rights, which determine whether the corresponding said user identity is censored from sending, in the communications, data presenting at least one of a pointer, video, audio, a graphic, and multimedia.

309. The method of claim **304**, wherein the determining whether the first user identity and the second user identity are able to form a group includes determining from access rights stored by user in the database that neither of the user identities is censored.

310. The method of claim **309**, wherein each said user identity is associated with a respective particular user's stored access rights, which determine whether the corresponding said user identity is censored from sending, in the communications, data presenting at least one of a pointer, video, audio, a graphic, and multimedia.

311. The method of claim **304**, further including determining a user age corresponding to each of the user identities.

312. The method of claim **311**, wherein each said user identity is associated with a respective particular user's stored access rights, which determine whether the corresponding said user identity is censored from sending, in the communications, data presenting at least one of a pointer, video, audio, a graphic, and multimedia.

313. The method of claim **304**, wherein at least one of the communications includes data presenting a human communication of sound.

46

314. The method of claim **313**, wherein each said user identity is associated with a respective particular user's stored access rights, which determine whether the corresponding said user identity is censored from sending, in the communications, data presenting at least one of a pointer, video, audio, a graphic, and multimedia.

315. The method of claim **304**, wherein each said user identity is associated with a respective particular user's stored access rights, which determine whether the corresponding said user identity is censored from sending, in the communications, data presenting at least one of a pointer, video, audio, a graphic, and multimedia.

316. The method of claim **189**, wherein the determining whether the first user identity is censored includes determining that the first user identity is censored from the sending of the data presenting the video and the audio and the graphic.

317. The method of claim **316**, wherein the computer system provides access via any of two client software alternatives, wherein both of the client software alternatives allow respective user identities to be recognized and allow at least some of the participator computers to form at least one group in which members can send communications and receive communications.

318. The method of claim **316**, further including determining whether at least one of the communications is censored based on content.

319. The method of claim **316**, wherein the determining whether the first user identity and the second user identity are able to form a group includes determining from access rights stored by user in the database that neither of the user identities is censored.

320. The method of claim **316**, further including determining a user age corresponding to each of the user identities.

321. The method of claim **316**, wherein at least one of the communications includes data presenting a human communication of sound.

322. The method of claim **189**, wherein the determining whether the first user identity is censored includes determining that the first user identity is censored from the sending of the data presenting the pointer and the video and the audio and the graphic.

323. The method of claim **322**, wherein the computer system provides access via any of two client software alternatives, wherein both of the client software alternatives allow respective user identities to be recognized and allow at least some of the participator computers to form at least one group in which members can send communications and receive communications.

324. The method of claim **323**, wherein each said user identity is associated with a respective particular user's stored access rights, which determine whether the corresponding said user identity is censored from sending, in the communications, data presenting at least one of a pointer, video, audio, a graphic, and multimedia.

325. The method of claim **322**, further including determining whether at least one of the communications is censored based on content.

326. The method of claim **325**, wherein each said user identity is associated with a respective particular user's stored access rights, which determine whether the corresponding said user identity is censored from sending, in the communications, data presenting at least one of a pointer, video, audio, a graphic, and multimedia.

327. The method of claim **322**, wherein the determining whether the first user identity and the second user identity are

47

able to form a group includes determining from access rights stored by user in the database that neither of the user identities is censored.

328. The method of claim **189**, wherein the determining whether the first user identity and the second user identity are able to form a group includes determining from access rights stored by user in the database that neither of the user identities is censored.

329. The method of claim **322**, further including determining a user age corresponding to each of the user identities.

330. The method of claim **329**, wherein each said user identity is associated with a respective particular user's stored access rights, which determine whether the corresponding said user identity is censored from sending, in the communications, data presenting at least one of a pointer, video, audio, a graphic, and multimedia.

331. The method of claim **322**, wherein at least one of the communications includes data presenting a human communication of sound.

332. The method of claim **331**, wherein each said user identity is associated with a respective particular user's stored access rights, which determine whether the corresponding said user identity is censored from sending, in the communications, data presenting at least one of a pointer, video, audio, a graphic, and multimedia.

333. The method of claim **322**, wherein each said user identity is associated with a respective particular user's stored access rights, which determine whether the corresponding said user identity is censored from sending, in the communications, data presenting at least one of a pointer, video, audio, a graphic, and multimedia.

334. The method of claim **189**, wherein the computer system provides access via any of two client software alternatives, wherein both of the client software alternatives allow respective user identities to be recognized and allow at least some of the participator computers to form at least one group in which members can send communications and receive communications.

335. The method of claim **334**, wherein each said user identity is associated with a respective particular user's stored access rights, which determine whether the corresponding said user identity is censored from sending, in the communications, data presenting at least one of a pointer, video, audio, a graphic, and multimedia.

336. The method of claim **189**, further including determining whether at least one of the communications is censored based on content.

337. The method of claim **336**, wherein each said user identity is associated with a respective particular user's stored access rights, which determine whether the corresponding said user identity is censored from sending, in the communications, data presenting at least one of a pointer, video, audio, a graphic, and multimedia.

338. The method of claim **327**, wherein each said user identity is associated with a respective user's stored access rights, which determine whether the corresponding said user identity is censored from sending, in the communications, data presenting at least one of a pointer, video, audio, a graphic, and multimedia.

339. The method of claim **328**, wherein each said user identity is associated with a respective particular user's stored access rights, which determine whether the corresponding said user identity is censored from sending, in the communications, data presenting at least one of a pointer, video, audio, a graphic, and multimedia.

340. The method of claim **189**, further including determining a user age corresponding to each of the user identities.

48

341. The method of claim **340**, wherein each said user identity is associated with a respective particular user's stored access rights, which determine whether the corresponding said user identity is censored from sending, in the communications, data presenting at least one of a pointer, video, audio, a graphic, and multimedia.

342. The method of claim **189**, wherein at least one of the communications includes data presenting a human communication of sound.

343. The method of claim **342**, wherein each said user identity is associated with a respective particular user's stored access rights, which determine whether the corresponding said user identity is censored from sending, in the communications, data presenting at least one of a pointer, video, audio, a graphic, and multimedia.

344. The method of claim **189**, wherein the computer system is comprised of an Internet service provider computer.

345. The method of claim **344**, wherein each said user identity is associated with a respective particular user's stored access rights, which determine whether the corresponding said user identity is censored from sending, in the communications, data presenting at least one of a pointer, video, audio, a graphic, and multimedia.

346. The method of claim **189**, further including: storing, for the first user identity, an authorization associated with presentation of graphical multimedia; and based on the authorization, facilitating presentation of the graphical multimedia at an output device corresponding to the second user identity.

347. The method of claim **346**, wherein each said user identity is associated with a respective particular user's stored access rights, which determine whether the corresponding said user identity is censored from sending, in the communications, data presenting at least one of a pointer, video, audio, a graphic, and multimedia.

348. The method of claim **189**, further including: providing the first user identity with access to a member-associated image corresponding to the second user identity.

349. The method of claim **348**, wherein each said user identity is associated with a respective particular user's stored access rights, which determine whether the corresponding said user identity is censored from sending, in the communications, data presenting at least one of a pointer, video, audio, a graphic, and multimedia.

350. The method of claim **189**, further including: determining whether the first user identity is censored from access to a member-associated image corresponding to the second user identity; if the first user identity is censored, not allowing access to the member-associated image; and if the first user identity is not censored, allowing access to the member-associated image.

351. The method of claim **350**, wherein each said user identity is associated with a respective particular user's stored access rights, which determine whether the corresponding said user identity is censored from sending, in the communications, data presenting at least one of a pointer, video, audio, a graphic, and multimedia.

352. The method of claim **189**, wherein each said user identity is associated with a respective particular user's stored access rights, which determine whether the corresponding said user identity is censored from sending, in the communications, data presenting at least one of a pointer, video, audio, a graphic, and multimedia.

353. A system to communicate over an Internet network, the system including:

a computer system including a controller computer and a database which serves as a repository of tokens for other programs to access, thereby affording information to each of a plurality of participator computers which are otherwise independent of each other, the computer system in communication with a first of the participator computers responsive to a first authenticated user identity and with a second of the participator computers responsive to a second authenticated user identity, wherein the computer system:

determines whether the first user identity and the second of the user identity are able to form a group to send and to receive real-time communications; and

determines whether the first user identity is individually censored from data in the communications, the data presenting at least one of a pointer, video, audio, a graphic, and multimedia by determining whether a respective at least one parameter corresponding to the first user identity has been determined by an other of the user identities; and

if the user identities are determined to be able to form the group, forms the group and facilitates receiving the communications that are sent and not censored from the second participator computer to the first participator computer, wherein the receiving is in real time and via the Internet network, and wherein the computer system facilitates, for the communications which are received and which present an Internet URL, handling the Internet URL via the computer system so as to find content specified by the Internet URL and facilitates presenting the content at an output device of the first participator computer; and

if the first user identity is censored from the data, does not facilitate the data that is censored to be presented from the second participator computer to the output device.

354. The system of claim **353**, wherein the data presents the pointer.

355. The system of claim **354**, wherein the computer system is further programmed to determine whether at least one of the communications is censored based on content.

356. The system of claim **355**, wherein the computer system associates each said user identity in the group with a respective particular user's stored access rights, which determine whether the corresponding said user identity is censored from receiving, and whether the corresponding said user identity is censored from sending, in the communications, data presenting at least one of a pointer, video, audio, a graphic, and multimedia.

357. The system of claim **354**, wherein the computer system determines whether at least one of the first user identity and the second user identity, individually, is censored from sending the communications data presenting at least one of the pointer, the video, the graphic, and the multimedia, and facilitating sending the communications that are not censored from the sending.

358. The system of claim **357**, wherein the computer system associates each said user identity in the group with a respective particular user's stored access rights, which determine whether the corresponding said user identity is censored from receiving, and whether the corresponding said user identity is censored from sending, in the communications, data presenting at least one of a pointer, video, audio, a graphic, and multimedia.

359. The system of claim **354**, wherein the computer system provides access via any of two client software alternatives, wherein both of the client software alternatives allow respective user identities to be recognized and allow at least some of the participator computers to form at least one group in which members can send communications and receive communications.

360. The system of claim **359**, wherein the computer system associates each said user identity in the group with a respective particular user's stored access rights, which determine whether the corresponding said user identity is censored from receiving, and whether the corresponding said user identity is censored from sending, in the communications, data presenting at least one of a pointer, video, audio, a graphic, and multimedia.

361. The system of claim **354**, wherein the computer system associates each said user identity in the group with a respective particular user's stored access rights, which determine whether the corresponding said user identity is censored from receiving, and whether the corresponding said user identity is censored from sending, in the communications, data presenting at least one of a pointer, video, audio, a graphic, and multimedia.

362. The system of claim **353**, wherein the data presents the video.

363. The system of claim **362**, wherein the computer system is further programmed to determine whether at least one of the communications is censored based on content.

364. The system of claim **362**, wherein the computer system determines whether at least one of the first user identity and the second user identity, individually, is censored from sending in the communications data presenting at least one of the pointer, the video, the graphic, and the multimedia, and facilitates sending the communications that are not censored from the sending.

365. The system of claim **362**, wherein the computer system provides access via any of two client software alternatives, wherein both of the client software alternatives allow respective user identities to be recognized and allow at least some of the participator computers to form at least one group in which members can send communications and receive communications.

366. The system of claim **353**, wherein the data presents the audio.

367. The system of claim **366**, wherein the computer system is further programmed to determine whether at least one of the communications is censored based on content.

368. The system of claim **366**, wherein the computer system determines whether at least one of the first user identity and the second user identity, individually, is censored from sending in the communications data presenting at least one of the pointer, the video, the graphic, and the multimedia, and facilitates sending the communications that are not censored from the sending.

369. The system of claim **366**, wherein the computer system provides access via any of two client software alternatives, wherein both of the client software alternatives allow respective user identities to be recognized and allow at least some of the participator computers to form at least one group in which members can send communications and receive communications.

370. The system of claim **353**, wherein the data presents the graphic.

371. The system of claim **370**, wherein the computer system is further programmed to determine whether at least one of the communications is censored based on content.

51

372. The system of claim 370, wherein the computer system determines whether at least one of the first user identity and the second user identity, individually, is censored from sending in the communications data presenting at least one of the pointer, the video, the graphic, and the multimedia, and facilitates sending the communications that are not censored from the sending.

373. The system of claim 370, wherein the computer system provides access via any of two client software alternatives, wherein both of the client software alternatives allow respective user identities to be recognized and allow at least some of the participator computers to form at least one group in which members can send communications and receive communications.

374. The system of claim 353, wherein the data presents the multimedia.

375. The system of claim 374, wherein the computer system is further programmed to determine whether at least one of the communications is censored based on content.

376. The system of claim 374, wherein the computer system determines whether at least one of the first user identity and the second user identity, individually, is censored from sending in the communications data presenting at least one of the pointer, the video, the graphic, and the multimedia, and facilitates sending the communications that are not censored from the sending.

377. The system of claim 374, wherein the computer system provides access via any of two client software alternatives, wherein both of the client software alternatives allow respective user identities to be recognized and allow at least some of the participator computers to form at least one group in which members can send communications and receive communications.

378. The system of claim 353, wherein the data presents the pointer and the video.

379. The system of claim 378, wherein the computer system is further programmed to determine whether at least one of the communications is censored based on content.

380. The system of claim 379, wherein the computer system associates each said user identity in the group with a respective particular user's stored access rights, which determine whether the corresponding said user identity is censored from receiving, and whether the corresponding said user identity is censored from sending, in the communications, data presenting at least one of a pointer, video, audio, a graphic, and multimedia.

381. The system of claim 378, wherein the computer system determines whether at least one of the first user identity and the second user identity, individually, is censored from sending in the communications data presenting at least one of the pointer, the video, the graphic, and the multimedia, and facilitates sending the communications that are not censored from the sending.

382. The system of claim 381, wherein the computer system associates each said user identity in the group with a respective particular user's stored access rights, which determine whether the corresponding said user identity is censored from receiving, and whether the corresponding said user identity is censored from sending, in the communications, data presenting at least one of a pointer, video, audio, a graphic, and multimedia.

383. The system of claim 378, wherein the computer system provides access via any of two client software alternatives, wherein both of the client software alternatives allow respective user identities to be recognized and allow at least

52

some of the participator computers to form at least one group in which members can send communications and receive communications.

384. The system of claim 383, wherein the computer system associates each said user identity in the group with a respective particular user's stored access rights, which determine whether the corresponding said user identity is censored from receiving, and whether the corresponding said user identity is censored from sending, in the communications, data presenting at least one of a pointer, video, audio, a graphic, and multimedia.

385. The system of claim 378, wherein the computer system associates each said user identity in the group with a respective particular user's stored access rights, which determine whether the corresponding said user identity is censored from receiving, and whether the corresponding said user identity is censored from sending, in the communications, data presenting at least one of a pointer, video, audio, a graphic, and multimedia.

386. The system of claim 353, wherein the data presents the pointer and the audio.

387. The system of claim 386, wherein the computer system is further programmed to determine whether at least one of the communications is censored based on content.

388. The system of claim 387, wherein the computer system associates each said user identity in the group with a respective particular user's stored access rights, which determine whether the corresponding said user identity is censored from receiving, and whether the corresponding said user identity is censored from sending, in the communications, data presenting at least one of a pointer, video, audio, a graphic, and multimedia.

389. The system of claim 386, wherein the computer system determines whether at least one of the first user identity and the second user identity, individually, is censored from sending in the communications data presenting at least one of the pointer, the video, the graphic, and the multimedia, and facilitates sending the communications that are not censored from the sending.

390. The system of claim 389, wherein the computer system associates each said user identity in the group with a respective particular user's stored access rights, which determine whether the corresponding said user identity is censored from receiving, and whether the corresponding said user identity is censored from sending, in the communications, data presenting at least one of a pointer, video, audio, a graphic, and multimedia.

391. The system of claim 386, wherein the computer system provides access via any of two client software alternatives, wherein both of the client software alternatives allow respective user identities to be recognized and allow at least some of the participator computers to form at least one group in which members can send communications and receive communications.

392. The system of claim 391, wherein the computer system associates each said user identity in the group with a respective particular user's stored access rights, which determine whether the corresponding said user identity is censored from receiving, and whether the corresponding said user identity is censored from sending, in the communications, data presenting at least one of a pointer, video, audio, a graphic, and multimedia.

393. The system of claim 386, wherein the computer system associates each said user identity in the group with a respective particular user's stored access rights, which determine whether the corresponding said user identity is censored from receiving, and whether the corresponding said user

53

identity is censored from sending, in the communications, data presenting at least one of a pointer, video, audio, a graphic, and multimedia.

394. The system of claim 353, wherein the data presents the pointer and the graphic.

395. The system of claim 394, wherein the computer system is further programmed to determine whether at least one of the communications is censored based on content.

396. The system of claim 395, wherein the computer system associates each said user identity in the group with a respective particular user's stored access rights, which determine whether the corresponding said user identity is censored from receiving, and whether the corresponding said user identity is censored from sending, in the communications, data presenting at least one of a pointer, video, audio, a graphic, and multimedia.

397. The system of claim 394, wherein the computer system determines whether at least one of the first user identity and the second user identity, individually, is censored from sending in the communications data presenting at least one of the pointer, the video, the graphic, and the multimedia, and facilitates sending the communications that are not censored from the sending.

398. The system of claim 397, wherein the computer system associates each said user identity in the group with a respective particular user's stored access rights, which determine whether the corresponding said user identity is censored from receiving, and whether the corresponding said user identity is censored from sending, in the communications, data presenting at least one of a pointer, video, audio, a graphic, and multimedia.

399. The system of claim 394, wherein the computer system provides access via any of two client software alternatives, wherein both of the client software alternatives allow respective user identities to be recognized and allow at least some of the participator computers to form at least one group in which members can send communications and receive communications.

400. The system of claim 399, wherein the computer system associates each said user identity in the group with a respective particular user's stored access rights, which determine whether the corresponding said user identity is censored from receiving, and whether the corresponding said user identity is censored from sending, in the communications, data presenting at least one of a pointer, video, audio, a graphic, and multimedia.

401. The system of claim 394, wherein the computer system associates each said user identity in the group with a respective particular user's stored access rights, which determine whether the corresponding said user identity is censored from receiving, and whether the corresponding said user identity is censored from sending, in the communications, data presenting at least one of a pointer, video, audio, a graphic, and multimedia.

402. The system of claim 353, wherein the data presents the video and the audio.

403. The system of claim 402, wherein the computer system is further programmed to determine whether at least one of the communications is censored based on content.

404. The system of claim 402, wherein the computer system determines whether at least one of the first user identity and the second user identity, individually, is censored from sending in the communications data presenting at least one of the pointer, the video, the graphic, and the multimedia, and facilitates sending the communications that are not censored from the sending.

54

405. The system of claim 402, wherein the computer system provides access via any of two client software alternatives, wherein both of the client software alternatives allow respective user identities to be recognized and allow at least some of the participator computers to form at least one group in which members can send communications and receive communications.

406. The system of claim 353, wherein the data presents the video and the graphic.

407. The system of claim 406, wherein the computer system is further programmed to determine whether at least one of the communications is censored based on content.

408. The system of claim 406, wherein the computer system determines whether at least one of the first user identity and the second user identity, individually, is censored from sending in the communications data presenting at least one of the pointer, the video, the graphic, and the multimedia, and facilitates sending the communications that are not censored from the sending.

409. The system of claim 406, wherein the computer system provides access via any of two client software alternatives, wherein both of the client software alternatives allow respective user identities to be recognized and allow at least some of the participator computers to form at least one group in which members can send communications and receive communications.

410. The system of claim 353, wherein the data presents the audio and the graphic.

411. The system of claim 410, wherein the computer system is further programmed to determine whether at least one of the communications is censored based on content.

412. The system of claim 410, wherein the computer system determines whether at least one of the first user identity and the second user identity, individually, is censored from sending in the communications data presenting at least one of the pointer, the video, the graphic, and the multimedia, and facilitates sending the communications that are not censored from the sending.

413. The system of claim 410, wherein the computer system provides access via any of two client software alternatives, wherein both of the client software alternatives allow respective user identities to be recognized and allow at least some of the participator computers to form at least one group in which members can send communications and receive communications.

414. The system of claim 353, wherein the data presents the pointer and the video and the audio.

415. The system of claim 414, wherein the computer system is further programmed to determine whether at least one of the communications is censored based on content.

416. The system of claim 415, wherein the computer system associates each said user identity in the group with a respective particular user's stored access rights, which determine whether the corresponding said user identity is censored from receiving, and whether the corresponding said user identity is censored from sending, in the communications, data presenting at least one of a pointer, video, audio, a graphic, and multimedia.

417. The system of claim 414, wherein the computer system determines whether at least one of the first user identity and the second user identity, individually, is censored from sending in the communications data presenting at least one of the pointer, the video, the graphic, and the multimedia, and facilitates sending the communications that are not censored from the sending.

418. The system of claim 417, wherein the computer system associates each said user identity in the group with a

55

respective particular user's stored access rights, which determine whether the corresponding said user identity is censored from receiving, and whether the corresponding said user identity is censored from sending, in the communications, data presenting at least one of a pointer, video, audio, a graphic, and multimedia.

419. The system of claim **414**, wherein the computer system provides access via any of two client software alternatives, wherein both of the client software alternatives allow respective user identities to be recognized and allow at least some of the participator computers to form at least one group in which members can send communications and receive communications.

420. The system of claim **419**, wherein the computer system associates each said user identity in the group with a respective particular user's stored access rights, which determine whether the corresponding said user identity is censored from receiving, and whether the corresponding said user identity is censored from sending, in the communications, data presenting at least one of a pointer, video, audio, a graphic, and multimedia.

421. The system of claim **414**, wherein the computer system associates each said user identity in the group with a respective particular user's stored access rights, which determine whether the corresponding said user identity is censored from receiving, and whether the corresponding said user identity is censored from sending, in the communications, data presenting at least one of a pointer, video, audio, a graphic, and multimedia.

422. The system of claim **353**, wherein the data presents the pointer and the video and the graphic.

423. The system of claim **422**, wherein the computer system is further programmed to determine whether at least one of the communications is censored based on content.

424. The system of claim **423**, wherein the computer system associates each said user identity in the group with a respective particular user's stored access rights, which determine whether the corresponding said user identity is censored from receiving, and whether the corresponding said user identity is censored from sending, in the communications, data presenting at least one of a pointer, video, audio, a graphic, and multimedia.

425. The system of claim **422**, wherein the computer system determines whether at least one of the first user identity and the second user identity, individually, is censored from sending in the communications data presenting at least one of the pointer, the video, the graphic, and the multimedia, and facilitates sending the communications that are not censored from the sending.

426. The system of claim **425**, wherein the computer system associates each said user identity in the group with a respective particular user's stored access rights, which determine whether the corresponding said user identity is censored from receiving, and whether the corresponding said user identity is censored from sending, in the communications, data presenting at least one of a pointer, video, audio, a graphic, and multimedia.

427. The system of claim **422**, wherein the computer system provides access via any of two client software alternatives, wherein both of the client software alternatives allow respective user identities to be recognized and allow at least some of the participator computers to form at least one group in which members can send communications and receive communications.

428. The system of claim **427**, wherein the computer system associates each said user identity in the group with a respective particular user's stored access rights, which deter-

56

mine whether the corresponding said user identity is censored from receiving, and whether the corresponding said user identity is censored from sending, in the communications, data presenting at least one of a pointer, video, audio, a graphic, and multimedia.

429. The system of claim **422**, wherein the computer system associates each said user identity in the group with a respective particular user's stored access rights, which determine whether the corresponding said user identity is censored from receiving, and whether the corresponding said user identity is censored from sending, in the communications, data presenting at least one of a pointer, video, audio, a graphic, and multimedia.

430. The system of claim **353**, wherein the data presents the pointer and the audio and the graphic.

431. The system of claim **430**, wherein the computer system is further programmed to determine whether at least one of the communications is censored based on content.

432. The system of claim **431**, wherein the computer system associates each said user identity in the group with a respective particular user's stored access rights, which determine whether the corresponding said user identity is censored from receiving, and whether the corresponding said user identity is censored from sending, in the communications, data presenting at least one of a pointer, video, audio, a graphic, and multimedia.

433. The system of claim **430**, wherein the computer system determines whether at least one of the first user identity and the second user identity, individually, is censored from sending in the communications data presenting at least one of the pointer, the video, the graphic, and the multimedia, and facilitates sending the communications that are not censored from the sending.

434. The system of claim **433**, wherein the computer system associates each said user identity in the group with a respective particular user's stored access rights, which determine whether the corresponding said user identity is censored from receiving, and whether the corresponding said user identity is censored from sending, in the communications, data presenting at least one of a pointer, video, audio, a graphic, and multimedia.

435. The system of claim **430**, wherein the computer system provides access via any of two client software alternatives, wherein both of the client software alternatives allow respective user identities to be recognized and allow at least some of the participator computers to form at least one group in which members can send communications and receive communications.

436. The system of claim **435**, wherein the computer system associates each said user identity in the group with a respective particular user's stored access rights, which determine whether the corresponding said user identity is censored from receiving, and whether the corresponding said user identity is censored from sending, in the communications, data presenting at least one of a pointer, video, audio, a graphic, and multimedia.

437. The system of claim **430**, wherein the computer system associates each said user identity in the group with a respective particular user's stored access rights, which determine whether the corresponding said user identity is censored from receiving, and whether the corresponding said user identity is censored from sending, in the communications, data presenting at least one of a pointer, video, audio, a graphic, and multimedia.

438. The system of claim **353**, wherein the data presents the video and the audio and the graphic.

57

439. The system of claim **438**, wherein the computer system is further programmed to determine whether at least one of the communications is censored based on content.

440. The system of claim **438**, wherein the computer system determines whether at least one of the first user identity and the second user identity, individually, is censored from sending in the communications data presenting at least one of the pointer, the video, the graphic, and the multimedia, and facilitates sending the communications that are not censored from the sending.

441. The system of claim **438**, wherein the computer system provides access via any of two client software alternatives, wherein both of the client software alternatives allow respective user identities to be recognized and allow at least some of the participator computers to form at least one group in which members can send communications and receive communications.

442. The system of claim **353**, wherein the data presents the pointer and the video and the audio and the graphic.

443. The system of claim **442**, wherein the computer system is further programmed to determine whether at least one of the communications is censored based on content.

444. The system of claim **443**, wherein the computer system associates each said user identity in the group with a respective particular user's stored access rights, which determine whether the corresponding said user identity is censored from receiving, and whether the corresponding said user identity is censored from sending, in the communications, data presenting at least one of a pointer, video, audio, a graphic, and multimedia.

445. The system of claim **442**, wherein the computer system determines whether at least one of the first user identity and the second user identity, individually, is censored from sending in the communications data presenting at least one of the pointer, the video, the graphic, and the multimedia, and facilitates sending the communications that are not censored from the sending.

446. The system of claim **445**, wherein the computer system associates each said user identity in the group with a respective particular user's stored access rights, which determine whether the corresponding said user identity is censored from receiving, and whether the corresponding said user identity is censored from sending, in the communications, data presenting at least one of a pointer, video, audio, a graphic, and multimedia.

447. The system of claim **442**, wherein the computer system provides access via any of two client software alternatives, wherein both of the client software alternatives allow respective user identities to be recognized and allow at least some of the participator computers to form at least one group in which members can send communications and receive communications.

448. The system of claim **447**, wherein the computer system associates each said user identity in the group with a respective particular user's stored access rights, which determine whether the corresponding said user identity is censored from receiving, and whether the corresponding said user identity is censored from sending, in the communications, data presenting at least one of a pointer, video, audio, a graphic, and multimedia.

449. The system of claim **442**, wherein the computer system associates each said user identity in the group with a respective particular user's stored access rights, which determine whether the corresponding said user identity is censored from receiving, and whether the corresponding said user

58

identity is censored from sending, in the communications, data presenting at least one of a pointer, video, audio, a graphic, and multimedia.

450. The system of claim **353**, wherein the computer system is further programmed to determine whether at least one of the communications is censored based on content.

451. The system of claim **450**, wherein the computer system associates each said user identity in the group with a respective particular user's stored access rights, which determine whether the corresponding said user identity is censored from receiving, and whether the corresponding said user identity is censored from sending, in the communications, data presenting at least one of a pointer, video, audio, a graphic, and multimedia.

452. The system of claim **353**, wherein the computer system determines whether at least one of the first user identity and the second user identity, individually, is censored from sending in the communications data presenting at least one of the pointer, the video, the graphic, and the multimedia, and facilitates sending the communications that are not censored from the sending.

453. The system of claim **452**, wherein the computer system associates each said user identity in the group with a respective particular user's stored access rights, which determine whether the corresponding said user identity is censored from receiving, and whether the corresponding said user identity is censored from sending, in the communications, data presenting at least one of a pointer, video, audio, a graphic, and multimedia.

454. The system of claim **353**, wherein the computer system provides access via any of two client software alternatives, wherein both of the client software alternatives allow respective user identities to be recognized and allow at least some of the participator computers to form at least one group in which members can send communications and receive communications.

455. The system of claim **454**, wherein the computer system associates each said user identity in the group with a respective particular user's stored access rights, which determine whether the corresponding said user identity is censored from receiving, and whether the corresponding said user identity is censored from sending, in the communications, data presenting at least one of a pointer, video, audio, a graphic, and multimedia.

456. The system of claim **353**, wherein the computer system provides access via any of two client software alternatives, wherein both of the client software alternatives allow respective user identities to be recognized and allow at least some of the participator computers to form at least one group in which members can send communications and receive communications.

457. The system of claim **456**, wherein the computer system associates each said user identity in the group with a respective particular user's stored access rights, which determine whether the corresponding said user identity is censored from receiving, and whether the corresponding said user identity is censored from sending, in the communications, data presenting at least one of a pointer, video, audio, a graphic, and multimedia.

458. The system of claim **353**, wherein the computer system is programmed to:

store, for the first user identity, an authorization associated with presentation of graphical data, and based on the authorization, allow the graphical data to be presented at an output device corresponding to the second user identity.

59

459. The system of claim **458**, wherein the computer system associates each said user identity in the group with a respective particular user's stored access rights, which determine whether the corresponding said user identity is censored from receiving, and whether the corresponding said user identity is censored from sending, in the communications, data presenting at least one of a pointer, video, audio, a graphic, and multimedia.

460. The system of claim **353**, wherein the computer system is programmed to:

provide the first user identity with access to a member-associated image corresponding to the second user identity.

461. The system of claim **460**, wherein the computer system associates each said user identity in the group with a respective particular user's stored access rights, which determine whether the corresponding said user identity is censored from receiving, and whether the corresponding said user identity is censored from sending, in the communications, data presenting at least one of a pointer, video, audio, a graphic, and multimedia.

462. The system of claim **353**, wherein the computer system is programmed to:

determine whether the first user identity is censored from access to a member-associated image corresponding to the second user identity,

if the first user identity is censored, not allowing access to member-associated image, and

if the first user identity is not censored, allow access to the member-associated image.

463. The system of claim **462**, wherein the computer system associates each said user identity in the group with a respective particular user's stored access rights, which determine whether the corresponding said user identity is censored from receiving, and whether the corresponding said user identity is censored from sending, in the communications, data presenting at least one of a pointer, video, audio, a graphic, and multimedia.

464. The system of claim **353**, wherein the computer system associates each said user identity in the group with a respective particular user's stored access rights, which determine whether the corresponding said user identity is censored from receiving, and whether the corresponding said user identity is censored from sending, in the communications, data presenting at least one of a pointer, video, audio, a graphic, and multimedia.

465. An Internet network communications system, the system including:

a computer system including a controller computer and a database which serves as a repository of tokens for other programs to access, thereby affording information to each of a plurality of participator computers which are otherwise independent of each other, the computer system in communication with a first of the participator computers responsive to a first authenticated user identity and with a second of the participator computers responsive to a second authenticated user identity, wherein the computer system

determines whether the first user identity and the second of the user identity are able to form a group to send and to receive real-time communications; and

determines whether the first user identity, is individually censored from sending data in the communications, the data presenting at least one of a pointer, video, audio, a graphic, and multimedia by determining whether a

60

respective at least one parameter corresponding to the first user identity has been determined by an other of the user identities; and

if the user identities are determined to be able to form the group, forms the group and facilitates sending the communications that are not censored from the first participator computer to the second participator computer, wherein the sending is in real time and via the Internet network, and wherein the computer system facilitates, for the communications which are received and which present an Internet URL, handling the Internet URL via the computer system so as to find content specified by the Internet URL and facilitates presenting the content at an output device of the second participator computer; and

if the first user identity is censored from sending the data, does not facilitate sending the data that is censored from the first participator computer to the second participator computer.

466. The system of claim **465**, wherein the data presents the pointer.

467. The system of claim **466**, wherein the computer system provides access via any of two client software alternatives, wherein both of the client software alternatives allow respective user identities to be recognized and allow at least some of the participator computers to form at least one group in which members can send communications and receive communications.

468. The system of claim **467**, wherein the computer system associates each said user identity in the group with a respective particular user's stored access rights, and determines whether the corresponding said user identity is censored from receiving, and whether the corresponding said user identity is censored from sending, in the communications, data presenting at least one of a pointer, video, audio, a graphic, and multimedia.

469. The system of claim **466**, wherein the computer system determines whether at least one of the communications is censored based on content.

470. The system of claim **469**, wherein the computer system associates each said user identity in the group with a respective particular user's stored access rights, and determines whether the corresponding said user identity is censored from receiving, and whether the corresponding said user identity is censored from sending, in the communications, data presenting at least one of a pointer, video, audio, a graphic, and multimedia.

471. The system of claim **466**, wherein at least one of the communications includes a human communication of sound.

472. The system of claim **471**, wherein the computer system associates each said user identity in the group with a respective particular user's stored access rights, and determines whether the corresponding said user identity is censored from receiving, and whether the corresponding said user identity is censored from sending, in the communications, data presenting at least one of a pointer, video, audio, a graphic, and multimedia.

473. The system of claim **466**, wherein the computer system determines from access rights stored by user that neither of the first user identity and the second user identity is censored from the group.

474. The system of claim **473**, wherein the computer system associates each said user identity in the group with a respective particular user's stored access rights, and determines whether the corresponding said user identity is censored from receiving, and whether the corresponding said

61

user identity is censored from sending, in the communications, data presenting at least one of a pointer, video, audio, a graphic, and multimedia.

475. The system of claim 466, wherein the computer system associates each said user identity in the group with a respective particular user's stored access rights, and determines whether the corresponding said user identity is censored from receiving, and whether the corresponding said user identity is censored from sending, in the communications, data presenting at least one of a pointer, video, audio, a graphic, and multimedia.

476. The system of claim 465, wherein data presents the video.

477. The system of claim 476, wherein the computer system provides access via any of two client software alternatives, wherein both of the client software alternatives allow respective user identities to be recognized and allow at least some of the participator computers to form at least one group in which members can send communications and receive communications.

478. The system of claim 476, wherein the computer system determines whether at least one of the communications is censored based on content.

479. The system of claim 476, wherein at least one of the communications includes a human communication of sound.

480. The system of claim 476, wherein the computer system determines from access rights stored by user that neither of the first user identity and the second user identity is censored from the group.

481. The system of claim 465, wherein the data presents the audio.

482. The system of claim 481, wherein the computer system provides access via any of two client software alternatives, wherein both of the client software alternatives allow respective user identities to be recognized and allow at least some of the participator computers to form at least one group in which members can send communications and receive communications.

483. The system of claim 481, wherein the computer system determines whether at least one of the communications is censored based on content.

484. The system of claim 481, wherein at least one of the communications includes a human communication of sound.

485. The system of claim 481, wherein the computer system determines from access rights stored by user that neither of the first user identity and the second user identity is censored from the group.

486. The system of claim 465, wherein the data presents the graphic.

487. The system of claim 486, wherein the computer system provides access via any of two client software alternatives, wherein both of the client software alternatives allow respective user identities to be recognized and allow at least some of the participator computers to form at least one group in which members can send communications and receive communications.

488. The system of claim 486, wherein the computer system determines whether at least one of the communications is censored based on content.

489. The system of claim 486, wherein at least one of the communications includes a human communication of sound.

490. The system of claim 486, wherein the computer system determines from access rights stored by user that neither of the first user identity and the second user identity is censored from the group.

491. The system of claim 465, wherein the data presents the multimedia.

62

492. The system of claim 491, wherein the computer system provides access via any of two client software alternatives, wherein both of the client software alternatives allow respective user identities to be recognized and allow at least some of the participator computers to form at least one group in which members can send communications and receive communications.

493. The system of claim 491, wherein the computer system determines whether at least one of the communications is censored based on content.

494. The system of claim 491, wherein at least one of the communications includes a human communication of sound.

495. The system of claim 491, wherein the computer system determines from access rights stored by user that neither of the first user identity and the second user identity is censored from the group.

496. The system of claim 465, wherein the data presents the pointer and the video.

497. The system of claim 496, wherein the computer system provides access via any of two client software alternatives, wherein both of the client software alternatives allow respective user identities to be recognized and allow at least some of the participator computers to form at least one group in which members can send communications and receive communications.

498. The system of claim 496, wherein the computer system determines whether at least one of the communications is censored based on content.

499. The system of claim 498, wherein the computer system associates each said user identity in the group with a respective particular user's stored access rights, and determines whether the corresponding said user identity is censored from receiving, and whether the corresponding said user identity is censored from sending, in the communications, data presenting at least one of a pointer, video, audio, a graphic, and multimedia.

500. The system of claim 496, wherein at least one of the communications includes a human communication of sound.

501. The system of claim 500, wherein the computer system associates each said user identity in the group with a respective particular user's stored access rights, and determines whether the corresponding said user identity is censored from receiving, and whether the corresponding said user identity is censored from sending, in the communications, data presenting at least one of a pointer, video, audio, a graphic, and multimedia.

502. The system of claim 496, wherein the computer system determines from access rights stored by user that neither of the first user identity and the second user identity is censored from the group.

503. The system of claim 502, wherein the computer system associates each said user identity in the group with a respective particular user's stored access rights, and determines whether the corresponding said user identity is censored from receiving, and whether the corresponding said user identity is censored from sending, in the communications, data presenting at least one of a pointer, video, audio, a graphic, and multimedia.

504. The system of claim 496, wherein the computer system associates each said user identity in the group with a respective particular user's stored access rights, and determines whether the corresponding said user identity is censored from receiving, and whether the corresponding said user identity is censored from sending, in the communications, data presenting at least one of a pointer, video, audio, a graphic, and multimedia.

63

505. The system of claim **465**, wherein the data presents the pointer and the audio.

506. The system of claim **505**, wherein the computer system provides access via any of two client software alternatives, wherein both of the client software alternatives allow
5 respective user identities to be recognized and allow at least some of the participator computers to form at least one group in which members can send communications and receive communications.

507. The system of claim **506**, wherein the computer system associates each said user identity in the group with a
10 respective particular user's stored access rights, and determines whether the corresponding said user identity is censored from receiving, and whether the corresponding said user identity is censored from sending, in the communications, data presenting at least one of a pointer, video, audio, a
15 graphic, and multimedia.

508. The system of claim **505**, wherein the computer system determines whether at least one of the communications is
20 censored based on content.

509. The system of claim **508**, wherein the computer system associates each said user identity in the group with a
25 respective particular user's stored access rights, and determines whether the corresponding said user identity is censored from receiving, and whether the corresponding said user identity is censored from sending, in the communications, data presenting at least one of a pointer, video, audio, a
30 graphic, and multimedia.

510. The system of claim **505**, wherein at least one of the communications includes a human communication of sound.

511. The system of claim **510**, wherein the computer system associates each said user identity in the group with a
35 respective particular user's stored access rights, and determines whether the corresponding said user identity is censored from receiving, and whether the corresponding said user identity is censored from sending, in the communications, data presenting at least one of a pointer, video, audio, a
40 graphic, and multimedia.

512. The system of claim **505**, wherein the computer system determines from access rights stored by user that neither
45 of the first user identity and the second user identity is censored from the group.

513. The system of claim **512**, wherein the computer system associates each said user identity in the group with a
50 respective particular user's stored access rights, and determines whether the corresponding said user identity is censored from receiving, and whether the corresponding said user identity is censored from sending, in the communications, data presenting at least one of a pointer, video, audio, a
55 graphic, and multimedia.

514. The system of claim **505**, wherein the computer system associates each said user identity in the group with a
60 respective particular user's stored access rights, and determines whether the corresponding said user identity is censored from receiving, and whether the corresponding said user identity is censored from sending, in the communications, data presenting at least one of a pointer, video, audio, a
65 graphic, and multimedia.

515. The system of claim **465**, wherein the data presents the pointer and the graphic.

516. The system of claim **515**, wherein the computer system provides access via any of two client software alternatives, wherein both of the client software alternatives allow
70 respective user identities to be recognized and allow at least some of the participator computers to form at least one group in which members can send communications and receive communications.

64

517. The system of claim **516**, wherein the computer system associates each said user identity in the group with a
75 respective particular user's stored access rights, and determines whether the corresponding said user identity is censored from receiving, and whether the corresponding said user identity is censored from sending, in the communications, data presenting at least one of a pointer, video, audio, a
80 graphic, and multimedia.

518. The system of claim **515**, wherein the computer system determines whether at least one of the communications is
85 censored based on content.

519. The system of claim **518**, wherein the computer system associates each said user identity in the group with a
90 respective particular user's stored access rights, and determines whether the corresponding said user identity is censored from receiving, and whether the corresponding said user identity is censored from sending, in the communications, data presenting at least one of a pointer, video, audio, a
95 graphic, and multimedia.

520. The system of claim **515**, wherein at least one of the communications includes a human communication of sound.

521. The system of claim **520**, wherein the computer system associates each said user identity in the group with a
100 respective particular user's stored access rights, and determines whether the corresponding said user identity is censored from receiving, and whether the corresponding said user identity is censored from sending, in the communications, data presenting at least one of a pointer, video, audio, a
105 graphic, and multimedia.

522. The system of claim **515**, wherein the computer system determines from access rights stored by user that neither
110 of the first user identity and the second user identity is censored from the group.

523. The system of claim **522**, wherein the computer system associates each said user identity in the group with a
115 respective particular user's stored access rights, and determines whether the corresponding said user identity is censored from receiving, and whether the corresponding said user identity is censored from sending, in the communications, data presenting at least one of a pointer, video, audio, a
120 graphic, and multimedia.

524. The system of claim **515**, wherein the computer system associates each said user identity in the group with a
125 respective particular user's stored access rights, and determines whether the corresponding said user identity is censored from receiving, and whether the corresponding said user identity is censored from sending, in the communications, data presenting at least one of a pointer, video, audio, a
130 graphic, and multimedia.

525. The system of claim **465**, wherein the data presents the video and the audio.

526. The system of claim **525**, wherein the computer system provides access via any of two client software alternatives, wherein both of the client software alternatives allow
135 respective user identities to be recognized and allow at least some of the participator computers to form at least one group in which members can send communications and receive communications.

527. The system of claim **525**, wherein the computer system determines whether at least one of the communications is
140 censored based on content.

528. The system of claim **525**, wherein at least one of the communications includes a human communication of sound.

529. The system of claim **525**, wherein the computer system determines from access rights stored by user that neither
145 of the first user identity and the second user identity is censored from the group.

65

530. The system of claim **465**, wherein the data presents the video and the graphic.

531. The system of claim **530**, wherein the computer wherein the computer system provides access via any of two client software alternatives, wherein both of the client software alternatives allow respective user identities to be recognized and allow at least some of the participator computers to form at least one group in which members can send communications and receive communications.

532. The system of claim **530**, wherein the computer system determines whether at least one of the communications is censored based on content.

533. The system of claim **530**, wherein at least one of the communications includes a human communication of sound.

534. The system of claim **530**, wherein the computer system determines from access rights stored by user that neither of the first user identity and the second user identity is censored from the group.

535. The system of claim **465**, wherein the data presents the pointer and the video and the audio.

536. The system of claim **535**, wherein the computer system provides access via any of two client software alternatives, wherein both of the client software alternatives allow respective user identities to be recognized and allow at least some of the participator computers to form at least one group in which members can send communications and receive communications.

537. The system of claim **536**, wherein the computer system associates each said user identity in the group with a respective particular user's stored access rights, and determines whether the corresponding said user identity is censored from receiving, and whether the corresponding said user identity is censored from sending, in the communications, data presenting at least one of a pointer, video, audio, a graphic, and multimedia.

538. The system of claim **535**, wherein the computer system determines whether at least one of the communications is censored based on content.

539. The system of claim **538**, wherein the computer system associates each said user identity in the group with a respective particular user's stored access rights, and determines whether the corresponding said user identity is censored from receiving, and whether the corresponding said user identity is censored from sending, in the communications, data presenting at least one of a pointer, video, audio, a graphic, and multimedia.

540. The system of claim **535**, wherein at least one of the communications includes a human communication of sound.

541. The system of claim **540**, wherein the computer system associates each said user identity in the group with a respective particular user's stored access rights, and determines whether the corresponding said user identity is censored from receiving, and whether the corresponding said user identity is censored from sending, in the communications, data presenting at least one of a pointer, video, audio, a graphic, and multimedia.

542. The system of claim **535**, wherein the computer system determines from access rights stored by user that neither of the first user identity and the second user identity is censored from the group.

543. The system of claim **542**, wherein the computer system associates each said user identity in the group with a respective particular user's stored access rights, and determines whether the corresponding said user identity is censored from receiving, and whether the corresponding said

66

user identity is censored from sending, in the communications, data presenting at least one of a pointer, video, audio, a graphic, and multimedia.

544. The system of claim **535**, wherein the computer system associates each said user identity in the group with a respective particular user's stored access rights, and determines whether the corresponding said user identity is censored from receiving, and whether the corresponding said user identity is censored from sending, in the communications, data presenting at least one of a pointer, video, audio, a graphic, and multimedia.

545. The system of claim **465**, wherein the data presents the pointer and the video and the graphic.

546. The system of claim **545**, wherein the computer system provides access via any of two client software alternatives, wherein both of the client software alternatives allow respective user identities to be recognized and allow at least some of the participator computers to form at least one group in which members can send communications and receive communications.

547. The system of claim **546**, wherein the computer system associates each said user identity in the group with a respective particular user's stored access rights, and determines whether the corresponding said user identity is censored from receiving, and whether the corresponding said user identity is censored from sending, in the communications, data presenting at least one of a pointer, video, audio, a graphic, and multimedia.

548. The system of claim **545**, wherein the computer system determines whether at least one of the communications is censored based on content.

549. The system of claim **548**, wherein the computer system associates each said user identity in the group with a respective particular user's stored access rights, and determines whether the corresponding said user identity is censored from receiving, and whether the corresponding said user identity is censored from sending, in the communications, data presenting at least one of a pointer, video, audio, a graphic, and multimedia.

550. The system of claim **545**, wherein at least one of the communications includes a human communication of sound.

551. The system of claim **550**, wherein the computer system associates each said user identity in the group with a respective particular user's stored access rights, and determines whether the corresponding said user identity is censored from receiving, and whether the corresponding said user identity is censored from sending, in the communications, data presenting at least one of a pointer, video, audio, a graphic, and multimedia.

552. The system of claim **545**, wherein the computer system determines from access rights stored by user that neither of the first user identity and the second user identity is censored from the group.

553. The system of claim **552**, wherein the computer system associates each said user identity in the group with a respective particular user's stored access rights, and determines whether the corresponding said user identity is censored from receiving, and whether the corresponding said user identity is censored from sending, in the communications, data presenting at least one of a pointer, video, audio, a graphic, and multimedia.

554. The system of claim **545**, wherein the computer system associates each said user identity in the group with a respective particular user's stored access rights, and determines whether the corresponding said user identity is censored from receiving, and whether the corresponding said

67

user identity is censored from sending, in the communications, data presenting at least one of a pointer, video, audio, a graphic, and multimedia.

555. The system of claim 465, wherein the data presents the pointer and the audio and the graphic.

556. The system of claim 555, wherein the computer system provides access via any of two client software alternatives, wherein both of the client software alternatives allow respective user identities to be recognized and allow at least some of the participator computers to form at least one group in which members can send communications and receive communications.

557. The system of claim 556, wherein the computer system associates each said user identity in the group with a respective particular user's stored access rights, and determines whether the corresponding said user identity is censored from receiving, and whether the corresponding said user identity is censored from sending, in the communications, data presenting at least one of a pointer, video, audio, a graphic, and multimedia.

558. The system of claim 555, wherein the computer system determines whether at least one of the communications is censored based on content.

559. The system of claim 558, wherein the computer system associates each said user identity in the group with a respective particular user's stored access rights, and determines whether the corresponding said user identity is censored from receiving, and whether the corresponding said user identity is censored from sending, in the communications, data presenting at least one of a pointer, video, audio, a graphic, and multimedia.

560. The system of claim 555, wherein at least one of the communications includes a human communication of sound.

561. The system of claim 560, wherein the computer system associates each said user identity in the group with a respective particular user's stored access rights, and determines whether the corresponding said user identity is censored from receiving, and whether the corresponding said user identity is censored from sending, in the communications, data presenting at least one of a pointer, video, audio, a graphic, and multimedia.

562. The system of claim 555, wherein the computer system determines from access rights stored by user that neither of the first user identity and the second user identity is censored from the group.

563. The system of claim 562, wherein the computer system associates each said user identity in the group with a respective particular user's stored access rights, and determines whether the corresponding said user identity is censored from receiving, and whether the corresponding said user identity is censored from sending, in the communications, data presenting at least one of a pointer, video, audio, a graphic, and multimedia.

564. The system of claim 555, wherein the computer system associates each said user identity in the group with a respective particular user's stored access rights, and determines whether the corresponding said user identity is censored from receiving, and whether the corresponding said user identity is censored from sending, in the communications, data presenting at least one of a pointer, video, audio, a graphic, and multimedia.

565. The system of claim 465, wherein the data presents the video and the audio and the graphic.

566. The system of claim 565, wherein the computer system provides access via any of two client software alternatives, wherein both of the client software alternatives allow respective user identities to be recognized and allow at least

68

some of the participator computers to form at least one group in which members can send communications and receive communications.

567. The system of claim 565, wherein the computer system determines whether at least one of the communications is censored based on content.

568. The system of claim 565, wherein at least one of the communications includes a human communication of sound.

569. The system of claim 565, wherein the computer system determines from access rights stored by user that neither of the first user identity and the second user identity is censored from the group.

570. The system of claim 465, wherein the data presents the pointer and the video and the audio and the graphic.

571. The system of claim 570, wherein the computer system provides access via any of two client software alternatives, wherein both of the client software alternatives allow respective user identities to be recognized and allow at least some of the participator computers to form at least one group in which members can send communications and receive communications.

572. The system of claim 571, wherein the computer system associates each said user identity in the group with a respective particular user's stored access rights, and determines whether the corresponding said user identity is censored from receiving, and whether the corresponding said user identity is censored from sending, in the communications, data presenting at least one of a pointer, video, audio, a graphic, and multimedia.

573. The system of claim 570, wherein the computer system determines whether at least one of the communications is censored based on content.

574. The system of claim 573, wherein the computer system associates each said user identity in the group with a respective particular user's stored access rights, and determines whether the corresponding said user identity is censored from receiving, and whether the corresponding said user identity is censored from sending, in the communications, data presenting at least one of a pointer, video, audio, a graphic, and multimedia.

575. The system of claim 570, wherein at least one of the communications includes a human communication of sound.

576. The system of claim 575, wherein the computer system associates each said user identity in the group with a respective particular user's stored access rights, and determines whether the corresponding said user identity is censored from receiving, and whether the corresponding said user identity is censored from sending, in the communications, data presenting at least one of a pointer, video, audio, a graphic, and multimedia.

577. The system of claim 570, wherein the computer system determines from access rights stored by user that neither of the first user identity and the second user identity is censored from the group.

578. The system of claim 577, wherein the computer system associates each said user identity in the group with a respective particular user's stored access rights, and determines whether the corresponding said user identity is censored from receiving, and whether the corresponding said user identity is censored from sending, in the communications, data presenting at least one of a pointer, video, audio, a graphic, and multimedia.

579. The system of claim 570, wherein the computer system associates each said user identity in the group with a respective particular user's stored access rights, and determines whether the corresponding said user identity is censored from receiving, and whether the corresponding said

69

user identity is censored from sending, in the communications, data presenting at least one of a pointer, video, audio, a graphic, and multimedia.

580. The system of claim **465**, wherein the computer system provides access via any of two client software alternatives, wherein both of the client software alternatives allow respective user identities to be recognized and allow at least some of the participator computers to form at least one group in which members can send communications and receive communications.

581. The system of claim **580**, wherein the computer system associates each said user identity in the group with a respective particular user's stored access rights, and determines whether the corresponding said user identity is censored from receiving, and whether the corresponding said user identity is censored from sending, in the communications, data presenting at least one of a pointer, video, audio, a graphic, and multimedia.

582. The system of claim **465**, wherein the computer system determines whether at least one of the communications is censored based on content.

583. The system of claim **582**, wherein the computer system associates each said user identity in the group with a respective particular user's stored access rights, and determines whether the corresponding said user identity is censored from receiving, and whether the corresponding said user identity is censored from sending, in the communications, data presenting at least one of a pointer, video, audio, a graphic, and multimedia.

584. The system of claim **465**, wherein at least one of the communications includes a human communication of sound.

585. The system of claim **584**, wherein the computer system associates each said user identity in the group with a respective particular user's stored access rights, and determines whether the corresponding said user identity is censored from receiving, and whether the corresponding said user identity is censored from sending, in the communications, data presenting at least one of a pointer, video, audio, a graphic, and multimedia.

586. The system of claim **465**, wherein the computer system determines from access rights stored by user that neither of the first user identity and the second user identity is censored from the group.

587. The system of claim **586**, wherein the computer system associates each said user identity in the group with a respective particular user's stored access rights, and determines whether the corresponding said user identity is censored from receiving, and whether the corresponding said user identity is censored from sending, in the communications, data presenting at least one of a pointer, video, audio, a graphic, and multimedia.

588. The system of claim **465**, wherein the computer system determines from access rights stored by user that neither of the first user identity and the second user identity is censored from the group.

589. The system of claim **588**, wherein the computer system associates each said user identity in the group with a respective particular user's stored access rights, and determines whether the corresponding said user identity is censored from receiving, and whether the corresponding said user identity is censored from sending, in the communications, data presenting at least one of a pointer, video, audio, a graphic, and multimedia.

590. The system of claim **465**, wherein the computer system is programmed to:

store, for the first user identity, an authorization associated with presentation of graphical data; and

70

based on the authorization, allow the graphical data to be presented at the output device corresponding to the second user identity.

591. The system of claim **590**, wherein the computer system associates each said user identity in the group with a respective particular user's stored access rights, and determines whether the corresponding said user identity is censored from receiving, and whether the corresponding said user identity is censored from sending, in the communications, data presenting at least one of a pointer, video, audio, a graphic, and multimedia.

592. The system of claim **465**, wherein the computer system is programmed to:

provide the first user identity with access to a member-associated image corresponding to the second user identity.

593. The system of claim **592**, wherein the computer system associates each said user identity in the group with a respective particular user's stored access rights, and determines whether the corresponding said user identity is censored from receiving, and whether the corresponding said user identity is censored from sending, in the communications, data presenting at least one of a pointer, video, audio, a graphic, and multimedia.

594. The system of claim **465**, wherein the computer system is programmed to:

determine whether the first user identity is censored from access to a member-associated image corresponding to the second user identity,

if the first user identity is censored, not allow access to the member-associated image, and

if the first user identity is not censored, allow access to the member-associated image.

595. The system of claim **594**, wherein the computer system associates each said user identity in the group with a respective particular user's stored access rights, and determines whether the corresponding said user identity is censored from receiving, and whether the corresponding said user identity is censored from sending, in the communications, data presenting at least one of a pointer, video, audio, a graphic, and multimedia.

596. The system of claim **465**, wherein the computer system associates each said user identity in the group with a respective particular user's stored access rights, and determines whether the corresponding said user identity is censored from receiving, and whether the corresponding said user identity is censored from sending, in the communications, data presenting at least one of a pointer, video, audio, a graphic, and multimedia.

597. An Internet network communication system, the system including:

a computer system including a controller computer and a database which serves as a repository of tokens for other programs to access, thereby affording information to participator computers that are otherwise independent of each other, in communication with each of the participator computers responsive to a respective authenticated user identity, the computers configured so as to

respond to one of the participator computers communicating a pointer in real time and via the Internet, wherein the pointer produces a pointer-triggered message on demand, by determining whether the first user identity is individually censored from content in the pointer-triggered message, by determining whether a parameter corresponding to the first user identity has been determined by an other of the user identities,

71

if the content is censored, disallow the pointer-triggered message from being presented at an output device of the participator computer corresponding to the first user identity, and

if the content is not censored, allow the pointer-triggered message to be presented, wherein the computer system facilitates handling an Internet URL via the computer system so as to find content specified by the Internet URL and facilitates presenting the pointer-triggered message at the output device.

598. The system of claim **597**, wherein the computer system is further programmed to:

send and receive communications between members in a group, the communications including data presenting at least one of video, sound, a graphic, and multimedia, the communications being sent and received in real time via the Internet network.

599. The system of claim **598**, wherein the data includes data presenting sound.

600. The system of claim **599**, wherein the computer system provides the participator computer corresponding to the first user identity with access to a member-associated image corresponding to the second user identity.

601. The system of claim **598**, wherein the data includes data presenting video.

602. The system of claim **601**, wherein the computer system provides the participator computer corresponding to the first user identity with access to a member-associated image corresponding to the second user identity.

603. The system of claim **598**, wherein the data includes data presenting sound and video.

604. The system of claim **603**, wherein the computer system provides the participator computer corresponding to the first user identity with access to a member-associated image corresponding to the second user identity.

605. The system of claim **598**, wherein the computer system provides the participator computer corresponding to the first user identity with access to a member-associated image corresponding to the second user identity.

606. A method of communicating via an Internet network by using a computer system including a controller computer and a database which serves as a repository of tokens for other programs to access, thereby affording information to each of a plurality of participator computers which are otherwise independent of each other, the method including:

affording some of the information to a first of the participator computers via the Internet network, responsive to an authenticated first user identity; and

affording some of the information to a second of the participator computers via the Internet network, responsive to an authenticated second user identity;

responsive to the first of the participator computers communicating a pointer in real time and via the Internet, the pointer producing a pointer-triggered message on demand, determining whether a parameter corresponding to the first user identity has been determined by an other of the user identities so that the first user identity is individually censored from content in the pointer-triggered message; and

if the content is censored, disallowing the pointer-triggered message to be presented at an output device of the first of the participator computers, and

if the content is not censored, allowing the pointer-triggered message to be presented, wherein the computer system facilitates handling an Internet URL via the computer system so as to find content specified by the

72

Internet URL and facilitates presenting the pointer-triggered message at the output device.

607. The method of claim **606**, further including sending and receiving communications between members in a group, the communications including data presenting at least one of video, sound, a graphic, and multimedia, the receiving in real time via the Internet network.

608. The method of claim **607**, wherein the data presents sound.

609. The method of claim **608**, further including: store, for the first user identity, an authorization associated with presentation of graphical multimedia; and based on the authorization, facilitate presentation of the graphical multimedia at the participator computer corresponding to the second user identity.

610. The method of claim **607**, wherein the data presents video.

611. The method of claim **610**, further including: store, for the first user identity, an authorization associated with presentation of graphical multimedia; and based on the authorization, facilitate presentation of the graphical multimedia the participator computer corresponding to the second user identity.

612. The method of claim **607**, wherein the data presents sound and video.

613. The method of claim **607**, further including: store, for the first user identity, an authorization associated with presentation of graphical multimedia; and based on the authorization, facilitate presentation of the graphical multimedia at the participator computer corresponding to the second user identity.

614. The method of claim **606**, further including sending and receiving communications between members in a group, the communications including data presenting a member-associated image, sound, and video.

615. The method of claim **606**, further including: store, for the first user identity, an authorization associated with presentation of graphical multimedia; and based on the authorization, facilitate presentation of the graphical multimedia at the participator computer corresponding to the second user identity.

616. A method of communicating via an Internet network by using a computer system including a controller computer and a database which serves as a repository of tokens for other programs to access, thereby affording information to each of a plurality of participator computers which are otherwise independent of each other, the method including:

affording some of the information to a first of the participator computers via the Internet network, responsive to an authenticated first user identity; and

affording some of the information to a second of the participator computers via the Internet network, responsive to an authenticated second user identity;

determining whether at least one of the first user identity and the second user identity is individually censored, by determining whether a parameter corresponding to said at least one has been determined by an other of the user identities, from receiving data comprising a pointer in communications that include at least one of text or ascii, the pointer being a pointer that produces a pointer-triggered message on demand;

determining whether the first and the second of the user identities are able to form a group; and

if the first and the second user identities are able to form the group, then forming the group and facilitating receiving the communications that are sent and not censored from one of the participator computers to another of the par-

73

participants computers, wherein the computer system facilitates handling an Internet URL via the computer system so as to find content specified by the Internet URL and facilitates presenting the content specified by the Internet URL at an output device of the other of the participants computers, and not allowing the data that is censored to be presented at the output device.

617. The method of claim **616**, wherein at least one of the communications includes data presenting sound.

618. The method of claim **617**, further including: storing, for the first user identity, an authorization associated with presentation of graphical multimedia; and based on the authorization, allowing presentation of the graphical multimedia at the participant computer corresponding to the second user identity.

619. The method of claim **616**, wherein at least one of the communications includes data presenting video.

620. The method of claim **619**, further including: storing, for the first user identity, an authorization associated with presentation of graphical multimedia; and based on the authorization, allowing presentation of the graphical multimedia at the participant computer corresponding to the second user identity.

621. The method of claim **616**, wherein at least one of the communications includes data presenting sound and video.

622. The method of claim **616**, further including: storing, for the first user identity, an authorization associated with presentation of graphical multimedia; and based on the authorization, allowing presentation of the graphical multimedia at the participant computer corresponding to the second user identity.

623. The method of claim **622**, wherein the graphical data includes graphical multimedia data.

624. The method of claim **616**, based on the authorization, presenting the graphical multimedia data at the output device corresponding to the second user identity, and wherein one of the determining steps includes determining whether a parameter corresponding to the first user identity has been determined by a user corresponding to another of the user identities.

625. A method of communicating via an Internet network by using a computer system including a controller computer and a database which serves as a repository of tokens for other programs to access, thereby affording information to each of a plurality of participant computers which are otherwise independent of each other, the method including:

affording some of the information to a first of the participant computers via the Internet network, responsive to an authenticated first user identity; and

affording some of the information to a second of the participant computers via the Internet network, responsive to an authenticated second user identity;

determining whether the first user identity and the second of the user identity are able to form a group to send and to receive real-time communications;

determining whether at least one of the first user identity and the second user identity is individually censored, by determining whether a parameter corresponding to said at least one has been determined by an other of the user identities, from sending a pointer in the communications including at least one of text or ascii, the pointer being a pointer that produces a pointer-triggered message on demand; and

if the first and the second user identities are able to form the group, then forming the group and facilitating sending the communications that are not censored from one of the participant computers to another of the participant

74

computers in real time over the Internet network, wherein the computer system facilitates handling an Internet URL via the computer system so as to find content specified by the Internet URL and facilitates presenting the content at an output device of the other of the participant computers, and not facilitating sending a pointer that is censored.

626. The method of claim **625**, wherein at least one of the communications includes data presenting sound.

627. The method of claim **626**, further including: storing, for the first user identity, an authorization associated with presentation of graphical multimedia; and based on the authorization, allowing presentation of the graphical multimedia at the participant computer corresponding to the second user identity.

628. The method of claim **625**, wherein at least one of the communications includes data presenting video.

629. The method of claim **628**, further including: storing, for the first user identity, an authorization associated with presentation of graphical multimedia; and based on the authorization, allowing presentation of the graphical multimedia at the participant computer corresponding to the second user identity.

630. The method of claim **625**, wherein at least one of the communications includes data presenting sound and video.

631. The method of claim **630**, further including: storing, for the first user identity, an authorization associated with presentation of graphical data; and based on the authorization, allowing presentation of the graphical data at the participant computer corresponding to the second user identity.

632. The method of claim **625**, further including: storing, for the first user identity, an authorization associated with presentation of graphical multimedia; and based on the authorization, allowing presentation of the graphical multimedia at the participant computer corresponding to the second user identity.

633. A system to communicate via an Internet network, the system including:

a computer system including a controller computer and a database which serves as a repository of tokens for other programs to access, thereby affording information to each of a plurality of participant computers which are otherwise independent of each other, the computer system in communication with a first of the participant computers responsive to a first authenticated user identity and with a second of the participant computers responsive to a second authenticated user identity, wherein the computers are configured to

determine whether at least one of the first user identity and the second user identity is individually censored, by determining whether a parameter corresponding to said at least one has been determined by an other of the user identities, from receiving, in communications, data comprising a pointer, the pointer producing a pointer-triggered message on demand, and

thereafter allow the participant computers to receive, in real time via the Internet network, and present the communications that are not censored, wherein the computer system facilitates, for the communications which are received and which present an Internet URL, handling the Internet URL via the computer system so as to find content specified by the Internet URL and facilitates presenting the content at an output device of one of the participant computers corresponding the user identity which presents the communications, and to not present

75

the data that is censored at an output device corresponding to the user identity that is censored from receiving the data.

634. The system of claim **633**, wherein at least one of the communications includes data presenting sound.

635. The system of claim **634**, wherein the computer system provides the participator computer corresponding to the first user identity with access to a member-associated image corresponding to the second user identity.

636. The system of claim **633**, wherein at least one of the communications includes data presenting video.

637. The system of claim **636**, wherein the computer system provides the participator computer corresponding to the first user identity with access to a member-associated image corresponding to the second user identity.

638. The system of claim **633**, wherein at least one of the communications includes data presenting sound and video.

639. The system of claim **638**, wherein the computer system provides the participator computer corresponding to the first user identity with access to a member-associated image corresponding to the second user identity.

640. The system of claim **633**, wherein the computer system provides the participator computer corresponding to the first user identity with access to a member-associated image corresponding to the second user identity.

641. A system to communicate via an Internet network, the system including:

a computer system including a controller computer and a database which serves as a repository of tokens for other programs to access, thereby affording information to each of a plurality of participator computers which are otherwise independent of each other, the computer system in communication with a first of the participator computers responsive to a first authenticated user identity and with a second of the participator computers responsive to a second authenticated user identity, wherein the computers are configured to

determine whether at least one of the first user identity and the second user identity is individually censored, by determining whether a parameter corresponding to said at least one has been determined by an other of the user identities, from sending, in communications, a pointer that produces a pointer-triggered message on demand, and

thereafter allow the participator computers to receive, in real time via the Internet network, and present the communications that are not censored based on the individual user identity, wherein the computer system facilitates, for the communications which are received and which present an Internet URL, handling the Internet URL via the computer system so as to find content specified by the Internet URL and facilitates presenting the content at an output device of one of the participator computers corresponding the user identity which presents the communications, and to not present the communications that are censored at an output device corresponding to the user identity that is censored from the sending.

642. The system of claim **641**, wherein at least one of the communications includes data presenting sound.

643. The system of claim **642**, wherein the computer system provides the participator computer corresponding to the first user identity with access to a member-associated image corresponding to the second user identity.

644. The system of claim **641**, wherein at least one of the communications includes data presenting sound.

76

645. The system of claim **644**, wherein the computer system provides the participator computer corresponding to the first user identity with access to a member-associated image corresponding to the second user identity.

646. The system of claim **641**, wherein at least one of the communications includes data presenting video.

647. The system of claim **646**, wherein the computer system provides the participator computer corresponding to the first user identity with access to a member-associated image corresponding to the second user identity.

648. The system of claim **641**, wherein the computer system provides the participator computer corresponding to the first user identity with access to a member-associated image corresponding to the second user identity.

649. A method communicating via an Internet network by using a computer system including a controller computer and a database which serves as a repository of tokens for other programs to access, thereby affording information to each of a plurality of participator computers which are otherwise independent of each other, the method including:

affording some of the information to a first of the participator computers via the Internet network, responsive to an authenticated first user identity, and affording some of the information to a second of the participator computers via the Internet network, responsive to an authenticated second user identity;

storing a respective particular user's access rights corresponding to each said user identity;

determining whether the first user identity and the second user identity are able to form a group to send and to receive real-time communications;

determining whether at least one of the first user identity and the second user identity is individually censored by the corresponding user's stored access rights from receiving data in the communications, the data presenting at least one of a pointer, video, audio, a graphic, and multimedia, by determining whether a respective at least one parameter corresponding to said at least one of the first user identity and the second user identity has been determined by an other of the user identities; and

if the first and the second user identities are able to form the group, forming the group and facilitating receiving the communications, including receiving at least some of the communications with the data that is not censored, that are sent from one of the participator computers to another of the participator computers, wherein the receiving is in real time via the Internet network and wherein the computer system facilitates, for the communications which are received and which present an Internet URL, handling the Internet URL via the computer system so as to find content specified by the Internet URL and facilitates presenting the content at an output device of the participator computer which is receiving the communications, and not allowing the data that is censored by the corresponding user's stored access rights to be presented at an output device of the participator computer corresponding to the user identity that is censored.

650. A method communicating via an Internet network by using a computer system including a controller computer and a database which serves as a repository of tokens for other programs to access, thereby affording information to each of a plurality of participator computers which are otherwise independent of each other, the method including:

affording some of the information to a first of the participator computers via the Internet network, responsive to

an authenticated first user identity, and affording some of the information to a second of the participator computers via the Internet network, responsive to an authenticated second user identity;

determining whether the first user identity and the second user identity are able to form a group to send and to receive data in communications in real time by determining whether at least one of the first user identity and the second user identity is individually censored from receiving the data in the communications, the data presenting at least one of a pointer, video, audio, a graphic, and multimedia, by determining whether a respective at least one parameter corresponding to said at least one of the first user identity and the second user identity has been determined by an other of the user identities; and if the first and the second user identities are determined to be able to form the group, forming the group and facilitating receiving the communications, including receiving at least some of the communications with the data that is not censored, that are sent from one of the participator computers to another of the participator computers, in real time via the Internet network and wherein the computer system facilitates, for the communications which are received and which present an Internet URL, handling the Internet URL via the computer system so as to find content specified by the Internet URL and facilitates presenting the content at an output device of the other of the participator computers; and

if the first and the second user identities are determined to not be able to form the group with respect to receiving the data that is censored, not forming the group.

651. A method communicating via an Internet network by using a computer system including a controller computer and a database which serves as a repository of tokens for other programs to access, thereby affording information to each of a plurality of participator computers which are otherwise independent of each other, the method including:

affording some of the information to a first of the participator computers via the Internet network, responsive to an authenticated first user identity, and affording some of the information to a second of the participator computers via the Internet network, responsive to an authenticated second user identity;

storing a respective particular user's access rights corresponding to each said user identity;

determining whether the first user identity and the second user identity are able to form a group to send and to receive real-time communications;

determining whether at least one of the first user identity and the second user identity is individually censored by the corresponding user's stored access rights from sending data in the communications, the data presenting at least one of a pointer, video, audio, a graphic, and multimedia by determining whether a respective at least one parameter corresponding to said at least one of the first user identity and the second user identity has been determined by an other of the user identities; and

if the first and the second user identities are able to form the group, forming the group and facilitating sending the communications, including sending at least some of the communications with the data that is not censored, from one of the participator computers to another of the participator computers, wherein the sending is in real time via the Internet network and wherein the computer system facilitates, for the communications which are received and which present an Internet URL, handling the Internet URL via the computer system so as to find

content specified by the Internet URL and facilitates presenting the content at an output device of the other of the participator computers, and not allowing sending the data that is censored by the corresponding user's stored access rights.

652. A method communicating via an Internet network by using a computer system including a controller computer and a database which serves as a repository of tokens for other programs to access, thereby affording information to each of a plurality of participator computers which are otherwise independent of each other, the method including:

affording some of the information to a first of the participator computers via the Internet network, responsive to an authenticated first user identity, and affording some of the information to a second of the participator computers via the Internet network, responsive to an authenticated second user identity;

determining whether a first of the user identities and a second of the user identities are able to form a group to send and to receive communications in real time by determining whether at least one of the first user identity and the second user identity is individually censored from sending data in the communications, the data presenting at least one of a pointer, video, audio, a graphic, and multimedia, by determining whether a respective at least one parameter corresponding to said at least one of the first user identity and the second user identity has been determined by an other of the user identities; and

if the first and the second user identities are determined to be able to form the group, forming the group and facilitating sending the communications, including sending at least some of the communications with the data that is not censored, from one of the participator computers to another of the participator computers in real time via the Internet network and wherein the computer system facilitates, for the communications which are received and which present an Internet URL, handling the Internet URL via the computer system so as to find content specified by the Internet URL and facilitates presenting the content at an output device of the other of the participator computers; and

if the first and the second user identities are determined to not be able to form the group with respect to sending the data that is censored, not forming the group.

653. A system to communicate via an Internet network, the system including:

a computer system including a controller computer and a database which serves as a repository of tokens for other programs to access, thereby affording information to each of a plurality of participator computers which are otherwise independent of each other, the computer system in communication with a first of the participator computers responsive to a first authenticated user identity and with a second of the participator computers responsive to a second authenticated user identity, wherein the computers are arranged so as to store a respective particular user's access rights corresponding to each said user identity,

determine whether the first user identity and the second user identity are able to form a group to send and to receive real-time communications,

determine whether at least one of the first user identity and the second user identity is individually censored by the corresponding user's stored access rights from receiving data in the communications, the data presenting at least one of a pointer, video, audio, a graphic, and multimedia, by determining whether a respective, at least one param-

79

eter corresponding to said at least one of the first user identity and the second user identity has been determined by an other of the user identities, and
 if the first and the second user identities are able to form the group, form the group and facilitate receiving the communications that are sent and not censored from one of the participator computers to another of the participator computers, wherein the receiving is in real time via the Internet network and wherein the computer system facilitates, for the communications which are received and which present an Internet URL, handling the Internet URL via the computer system so as to find content specified by the Internet URL and facilitates presenting the content at an output device of the other of the participator computers, and
 not allow the data that is censored by the corresponding user's stored access rights to be presented at an output device of the participator computer corresponding to the user identity that is censored.

654. A system to communicate via an Internet network, the system including:

a computer system including a controller computer and a database which serves as a repository of tokens for other programs to access, thereby affording information to each of a plurality of participator computers which are otherwise independent of each other, the computer system in communication with a first of the participator computers responsive to a first authenticated user identity and with a second of the participator computers responsive to a second authenticated user identity, wherein the computers are arranged so as to determine whether the first user identity and the second user identity are able to form a group to send and to receive real-time communications by determining whether at least one of the first user identity and the second user identity is individually censored from receiving data in the communications, the data presenting at least one of a pointer, video, audio, a graphic, and multimedia, by determining whether a respective at least one parameter corresponding to said at least one of the first user identity and the second user identity has been determined by an other of the user identities, and

if the first and the second user identities are determined to be able to form the group, form the group and facilitate receiving the communications from one of the participator computers to an other of the participator computers, in real time via the Internet network and wherein the computer system facilitates, for the communications which are received and which present an Internet URL, handling the Internet URL via the computer system so as to find content specified by the Internet URL and facilitates presenting the content at an output device of the other of the participator computers, and

if the first and the second user identities are determined to not be able to form the group with respect to receiving the data that is censored, not form the group.

655. A system to communicate via an Internet network, the system including:

a computer system including a controller computer and a database which serves as a repository of tokens for other programs to access, thereby affording information to each of a plurality of participator computers which are otherwise independent of each other, the computer system in communication with a first of the participator computers responsive to a first authenticated user identity

80

ity and with a second of the participator computers responsive to a second authenticated user identity, wherein the computers are arranged so as to store a respective particular user's access rights corresponding to each said user identity,

determine whether the first user identity and the second user identity are able to form a group to send and to receive real-time communications,

determine whether at least one of the first user identity and the second user identity is individually censored by the corresponding user's stored access rights from sending data in the communications, the data including at least one of a pointer, video, audio, a graphic, and multimedia, by determining whether a respective at least one parameter corresponding to said at least one of the first user identity and the second user identity has been determined by an other of the user identities, and

if the first and the second user identities are able to form the group, and facilitate sending the communications that are not censored from one of the participator computers to another of the participator computers, wherein the sending is in real time via the Internet network and wherein the computer system facilitates, for the communications which are received and which present an Internet URL, handling the Internet URL via the computer system so as to find content specified by the Internet URL and facilitates presenting the content at an output device of the other of the participator computers, and not allow sending the data that is censored by the corresponding user's stored access rights.

656. A system to communicate via an Internet network, the system including:

a computer system including a controller computer and a database which serves as a repository of tokens for other programs to access, thereby affording information to each of a plurality of participator computers which are otherwise independent of each other, the controller computer system in communication with a first of the participator computers responsive to a first authenticated user identity and with a second of the participator computers responsive to a second authenticated user identity, wherein the computers are arranged so as to

determine whether a first of the user identities and a second of the user identities are able to form a group to send and to receive communications in real time by determining whether at least one of the first user identity and the second user identity is individually censored from sending data in the communications, the data presenting at least one of a pointer, video, audio, a graphic, and multimedia, by determining whether a respective at least one parameter corresponding to said at least one of the first user identity and the second user identity has been determined by an other of the user identities, and

if the first and the second user identities are determined to be able to form the group, form the group and facilitate sending the communications from one of the participator computers to another of the participator computers, wherein the sending is in real time via the Internet network and wherein the computer system facilitates, for the communications which are received and which present an Internet URL, handling the Internet URL via the computer system so as to find content specified by the Internet URL and facilitates

81

presenting the content at an output device of the other of the participator computers, and

if the first and the second user identities are determined to not be able to form the group with respect to sending the data that is censored, not form the group.

657. A method communicating via an Internet network by using a computer system including a controller computer that is an Internet service provider computer and a database which serves as a repository of tokens for other programs to access, thereby affording information to each of a plurality of participator computers which are otherwise independent of each other, the method including:

affording some of the information to a first of the participator computers via the Internet network, responsive to an authenticated first user identity, and affording some of the information to a second of the participator computers via the Internet network, responsive to an authenticated second user identity; and

storing a respective particular user's access rights corresponding to each said user identity;

determining whether the first user identity and the second user identity are able to form a group to send and to receive real-time communications; and

determining, based on the access rights of the first user identity by determining whether a parameter corresponding to the first user identity has been determined by an other of the user identities, whether the first user identity is individually censored from receiving content in the communications;

if the user identities are determined to be able to form the group, forming the group and facilitating receiving the communications that are sent and not censored from the second participator computer to the first participator computer, wherein the receiving is in real time and via the Internet network and wherein the computer system facilitates, for the communications which are received and which present an Internet URL, handling the Internet URL via the computer system so as to find content specified by the Internet URL and facilitates presenting the content at an output device of the other of the participator computers, and

if the first user identity is censored, not allowing the content that is censored to be presented from the second participator computer to a user of the first participator computer.

658. A method communicating via an Internet network by using a computer system including a controller computer that is an Internet service provider computer and a database which serves as a repository of tokens for other programs to access, thereby affording information to each of a plurality of participator computers which are otherwise independent of each other, the method including:

affording some of the information to a first of the participator computers via the Internet network, responsive to an authenticated first user identity, and affording some of the information to a second of the participator computers via the Internet network, responsive to an authenticated second user identity; and

storing a respective particular user's access rights corresponding to each said user identity;

determining whether the first user identity and the second user identity are able to form a group to send and to receive real-time communications; and

determining, based on the access rights of the first user identity by determining whether a parameter corresponding to the first user identity has been determined

82

by an other of the user identities, whether the first user identity is individually censored from sending content in the communications;

if the user identities are determined to be able to form the group, forming the group and facilitating sending the communications that are not censored from the first participator computer to the second participator computer, wherein the sending is in real time and via the Internet network and wherein the computer system facilitates, for the communications which are received and which present an Internet URL, handling the Internet URL via the computer system so as to find content specified by the Internet URL and facilitates presenting the content at an output device of the second participator computer, and

if the first user identity is censored, not allowing the content that is censored to be sent from the first participator computer to the second participator computer.

659. A method communicating via an Internet network by using a computer system including a controller computer that is an Internet service provider computer and a database which serves as a repository of tokens for other programs to access, thereby affording information to each of a plurality of participator computers which are otherwise independent of each other, the method including:

affording some of the information to a first of the participator computers via the Internet network, responsive to an authenticated first user identity, and affording some of the information to a second of the participator computers via the Internet network, responsive to an authenticated second user identity; and

determining whether the first user identity and the second user identity are able to form a group to send and to receive real-time communications; and

determining whether the first user identity is individually censored from data in the communications, the data presenting at least one of an Internet URL, video, audio, a graphic, and multimedia, by determining whether a respective at least one parameter corresponding to said at least one of the first user identity and the second user identity has been determined by an other of the user identities; and

if the user identities are determined to be able to form the group, forming the group and facilitating receiving the communications that are sent and not censored from the second participator computer to the first participator computer, wherein the receiving is in real time and via the Internet network and wherein the computer system facilitates, for the communications which are received and which present the Internet URL, handling the Internet URL via the computer system so as to find content specified by the Internet URL and facilitates presenting the content at an output device of the first participator computer, and

if the first user identity is censored, not allowing the data that is censored to be presented from the second participator computer to a user of the first participator computer.

660. A method communicating via an Internet network by using a computer system including a controller computer that is an Internet service provider computer and a database which serves as a repository of tokens for other programs to access, thereby affording information to each of a plurality of participator computers which are otherwise independent of each other, the method including:

affording some of the information to a first of the participator computers via the Internet network, responsive to

83

an authenticated first user identity, and affording some of the information to a second of the participator computers via the Internet network, responsive to an authenticated second user identity; and

determining whether the first user identity and the second user identity are able to form a group to send and to receive real-time communications; and

determining whether the first user identity is individually censored from sending data in the communications, the data presenting at least one of an Internet URL, video, audio, a graphic, and multimedia, by determining whether a respective parameter corresponding to the first user identity has been determined by an other of the user identities; and

if the user identities are determined to be able to form the group, forming the group and facilitating sending the communications that are not censored from the first participator computer to the second participator computer, wherein the sending is in real time and via the Internet network and wherein the computer system facilitates, for the communications which are received and which present the Internet URL, handling the Internet URL via the computer system so as to find content specified by the Internet URL and facilitates presenting the content at an output device of the second participator computer, and

if the first user identity is censored, not allowing sending the data that is censored from the first participator computer to the second participator computer.

661. A system to communicate via an Internet network, the system including:

a computer system including a controller computer that is an Internet service provider computer and a database which serves as a repository of tokens for other programs to access, thereby affording information to each of a plurality of participator computers which are otherwise independent of each other, the computer system in communication with a first of the participator computers responsive to a first authenticated user identity and with a second of the participator computers responsive to a second authenticated user identity, wherein the computers are arranged so as to

determine whether the first user identity is individually censored from receiving content in the communications, by determining whether a parameter corresponding to the first user identity has been determined by an other of the user identities,

if the user identities are determined to be able to form the group, form the group and facilitate receiving the communications that are sent and not censored from the second participator computer to the first participator computer, wherein the receiving is in real time and via the Internet network and wherein the computer system facilitates, for the communications which are received and which present an Internet URL, handling the Internet URL via the computer system so as to find content specified by the Internet URL and facilitates presenting the content at an output device of the other of the participator computers at an output device of the first participator computer, and

if the first user identity is censored, not allow the content that is censored to be presented from the second participator computer at the first participator computer.

662. A system to communicate via an Internet network, the system including:

a computer system including a controller computer that is an Internet service provider computer and a database

84

which serves as a repository of tokens for other programs to access, thereby affording information to each of a plurality of participator computers which are otherwise independent of each other, the computer system in communication with a first of the participator computers responsive to a first authenticated user identity and with a second of the participator computers responsive to a second authenticated user identity, wherein the computers are arranged so as to

determine whether the first user identity and the second user identity are able to form a group to send and to receive real-time communications, and

determine whether the first user identity is individually censored from sending content in the communications, by determining whether a parameter corresponding to the first user identity has been determined by an other of the user identities,

if the user identities are determined to be able to form the group, form the group and facilitate sending the communications that are not censored from the first participator computer to the second participator computer, wherein the sending is in real time and via the Internet network and wherein the computer system facilitates, for the communications which are received and which present an Internet URL, handling the Internet URL via the computer system so as to find content specified by the Internet URL and facilitates presenting the content at an output device of the other of the participator computers at an output device of the second participator computer, and

if the first user identity is censored, not allow the content that is censored to be sent from the first participator computer the second participator computer.

663. A system to communicate via an Internet network, the system including:

a computer system including a controller computer that is an Internet service provider computer and a database which serves as a repository of tokens for other programs to access, thereby affording information to each of a plurality of participator computers which are otherwise independent of each other, the computer system in communication with a first of the participator computers responsive to a first authenticated user identity and with a second of the participator computers responsive to a second authenticated user identity, wherein the computers are arranged so as to

determine whether the first user identity and the second user identity are able to form a group to send and to receive real-time communications, and

determine whether the first user identity is individually censored from sending content in the communications, by determining whether a parameter corresponding to the first user identity has been determined by an other of the user identities,

if the user identities are determined to be able to form the group, form the group and facilitate sending the communications that are not censored from the first participator computer to the second participator computer, wherein the sending is in real time and via the Internet network and wherein the computer system facilitates, for the communications which are received and which present an Internet URL, handling the Internet URL via the computer system so as to find content specified by the Internet URL and facilitates presenting the content at an output device of the other of the participator computers, and

85

if the first user identity is censored, not allow the content that is censored to be sent from the first participator computer to the second participator computer.

664. The method of claim 663, wherein each said user identity in the group is associated with a respective particular user's stored access rights, which determine whether the corresponding said user identity is censored from receiving, in the communications, data presenting at least one of a pointer, video, audio, a graphic, and multimedia.

665. The method of claim 663, further including: determining whether the first user identity is censored from the data by determining whether a parameter corresponding to the first user identity has been determined by a user corresponding to an other of the user identities.

666. A system to communicate via an Internet network, the system including:

a computer system including a controller computer that is an Internet service provider computer and a database which serves as a repository of tokens for other programs to access, thereby affording information to each of a plurality of participator computers which are otherwise independent of each other, the computer system in communication with a first of the participator computers responsive to a first authenticated user identity and with a second of the participator computers responsive to a second authenticated user identity, wherein the computers are arranged so as to

determine whether a first of the user identities and a second of the user identities are able to form a group to send and to receive communications in real time by determining whether at least one of the first user identity and the second user identity is individually censored from data in the communications, the data presenting at least one of a pointer, video, audio, graphic, and multimedia, by determining whether a respective at least one parameter corresponding to said at least one of the first user identity and the second user identity has been determined by an other of the user identities, and

if the first and the second user identities are determined to be able to form the group, form the group and facilitate receiving the communications that are sent and include said data that is not censored from one of the participator computers to another of the participator computers, wherein the receiving is in real time via the Internet network and wherein the computer system facilitates, for the communications which are received and which present an Internet URL, handling the Internet URL via the computer system so as to find content specified by the Internet URL and facilitates presenting the content at an output device of the other of the participator computers at an output device of the other of the participator computers, and

if the first and the second user identities are determined to not be able to form the group, not form the group.

667. A system to communicate via an Internet network, the system including:

a computer system including a controller computer that is an Internet service provider computer and a database which serves as a repository of tokens for other programs to access, thereby affording information to each of a plurality of participator computers which are otherwise independent of each other, the computer system in communication with a first of the participator computers responsive to a first authenticated user identity and with a second of the participator computers responsive to a second authenticated user identity, wherein the computers are configured so as to

86

allow the first user identity and the second user identity to send communications and to receive communications sent by another user identity on at least one of a plurality of channels, wherein at least some of the communications are received in real time via the Internet network, except that if at least one of the user identities is individually censored, from data in one of the channels, the data presenting at least one of a pointer, video, audio, graphic, or multimedia, and multimedia, by a determination of whether a respective at least one parameter corresponding to said at least one of the first user identity and the second user identity has been determined by an other of the user identities, the data that is censored is not presented by the participator computer corresponding to the user identity that is censored from the data, and otherwise allow the data to be presented at an output device corresponding to the participator computer which receives the data, wherein the computer system facilitates, for the communications which are received and which present an Internet URL, handling the Internet URL via the computer system so as to find content specified by the Internet URL and facilitates presenting the content at the output device.

668. A system to communicate via an Internet network, the system including:

a computer system including a controller computer that is an Internet service provider computer and a database which serves as a repository of tokens for other programs to access, thereby affording information to each of a plurality of participator computers which are otherwise independent of each other, the computer system in communication with a first of the participator computers responsive to a first authenticated user identity and with a second of the participator computers responsive to a second authenticated user identity, wherein the computers are configured so as to censor communications based on:

whether the first user identity and the second of the user identity are able to form a group to send and to receive real-time communications, and

whether the first user identity, is individually censored from sending data in the communications, the data presenting at least one of a pointer, video, audio, a graphic, and multimedia, by determining whether a respective at least one parameter corresponding to the first user identity has been determined by an other of the user identities; and

if the user identities are able to form the group, form the group and facilitate receiving the communications that are sent and not censored from the first participator computer to the second participator computer, wherein the sending is in real time and via the Internet network and wherein the computer system facilitates handling an Internet URL via the computer system so as to find content specified by the Internet URL and facilitates presenting the content at an output device of the second participator computer;

if the first user identity is censored, not allowing the data that is censored to be sent from the first participator computer to the second participator computer.

669. A system to communicate via an Internet network, the system including:

a computer system including a controller computer that is an Internet service provider computer and a database which serves as a repository of tokens for other programs to access, thereby affording information to each

87

of a plurality of participator computers which are otherwise independent of each other, the computer system in communication with a first of the participator computers responsive to a first authenticated user identity and with a second of the participator computers responsive to a second authenticated user identity, wherein the computers are configured so as to censor communications based on:

whether the first user identity and the second of the user identity are able to form a group to send and to receive real-time communications, and

whether the first user identity, is individually censored from receiving data in the communications, the data presenting at least one of a pointer, video, audio, a graphic, and multimedia, by determining whether a respective at least one parameter corresponding to the first user identity has been determined by an other of the user identities; and

if the user identities are able to form the group, form the group and facilitate receiving the communications that are sent and not censored from the second participator computer to the first participator computer, wherein the receiving is in real time and via the Internet network and wherein the computer system facilitates, for the communications which are received and which present an Internet URL, handling the Internet URL via the computer system so as to find content specified by the Internet URL and facilitates presenting the content at an output device of the first participator computer;

if the first user identity is censored, not allowing the data that is censored to be presented from the second participator computer at the output device.

670. A system to communicate via an Internet network, the system including:

a computer system including a controller computer that is an Internet service provider computer and a database which serves as a repository of tokens for other programs to access, thereby affording information to each of a plurality of participator computers which are otherwise independent of each other, the computer system in communication with a first of the participator computers responsive to a first authenticated user identity and with a second of the participator computers responsive to a second authenticated user identity, wherein the computers are configured so as to

store a respective particular user's access rights corresponding to each said user identity, and

determine whether the first user identity and the second of the user identity are able to form a group to send and to receive real-time communications, and

determine whether the first user identity, is individually censored from sending data in the communications, the data presenting at least one of a pointer, video, audio, a graphic, and multimedia, by determining whether a respective at least one parameter corresponding to the first user identity has been determined by an other of the user identities, such that

88

if the user identities are determined to be able to form the group, form the group and facilitate receiving the communications that are sent and not censored from the first participator computer to the second participator computer, wherein the sending is in real time and via the Internet network and wherein the computer system facilitates, for the communications which are received and which present an Internet URL, handling the Internet URL via the computer system so as to find content specified by the Internet URL and facilitates presenting the content at an output device of the second participator computer, and if the first user identity is censored, not send of the data that is censored from the first participator computer to the second participator computer.

671. A system to communicate via an Internet network, the system including:

a computer system including a controller computer that is an Internet service provider computer and a database which serves as a repository of tokens for other programs to access, thereby affording information to each of a plurality of participator computers which are otherwise independent of each other, the computer system in communication with a first of the participator computers responsive to a first authenticated user identity and with a second of the participator computers responsive to a second authenticated user identity, wherein the computers are configured so as to

store a respective particular user's access rights corresponding to each said user identity, and

determine whether the first user identity and the second user identity are able to form a group to send and to receive real-time communications, and

determine whether the first user identity is individually censored from sending data in the communications, the data presenting at least one of an Internet URL, video, audio, a graphic, multimedia, by determining whether a respective at least one parameter corresponding to the first user identity has been determined by an other of the user identities, such that

if the user identities are determined to be able to form the group, forming the group and facilitating sending the communications that are not censored from the first participator computer to the second participator computer, wherein the sending is in real time and via the Internet network and wherein the computer system facilitates, for the communications which are received and which present an Internet URL, handling the Internet URL via the computer system so as to find content specified by the Internet URL and facilitates presenting the content at an output device of the second participator computer, and

if the first user identity is censored, not allowing sending the data that is censored from the first participator computer to the second participator computer.

* * * * *