



US006115468A

United States Patent [19]
De Nicolo

[11] **Patent Number:** **6,115,468**
[45] **Date of Patent:** **Sep. 5, 2000**

[54] **POWER FEED FOR ETHERNET
TELEPHONES VIA ETHERNET LINK**

5,574,748 11/1996 Vander Mey et al. 375/204
5,799,040 8/1998 Lau 375/258
5,994,998 11/1999 Fisher et al. 340/310.01

[75] Inventor: **Maurilio Tazio De Nicolo**, Saratoga,
Calif.

Primary Examiner—David R. Hudspeth
Assistant Examiner—Vijay B Chawan
Attorney, Agent, or Firm—D'Alessandro & Ritchie

[73] Assignee: **Cisco Technology, Inc.**, San Jose, Calif.

[57] **ABSTRACT**

[21] Appl. No.: **09/048,922**

An Ethernet device power transmission system includes an input transformer, an output transformer and a pair of twisted pair conductors. The input transformer includes a pair of primaries for connection to a source of Ethernet data. The input transformer also includes a pair of secondaries, each having a center-tap. A first twisted pair conductor is connected across the first secondary, a second twisted pair conductor is connected across the second secondary and a DC-bias is provided between the respective center taps of the first and second secondaries. At the local end, the output transformer includes a first and second center-tapped primary and a first and second secondary for connection to the load device. The first and second primary center taps are connected to a power processor for extraction of DC power.

[22] Filed: **Mar. 26, 1998**

[51] **Int. Cl.⁷** **H04B 3/00**

[52] **U.S. Cl.** **379/413; 379/412; 379/900;**
379/324; 375/258; 375/257; 375/285

[58] **Field of Search** **379/413, 412,**
379/900, 324; 375/285, 257, 258

[56] **References Cited**

U.S. PATENT DOCUMENTS

4,723,267	2/1988	Jones et al.	379/93
5,285,477	2/1994	Leonowich	375/258
5,311,518	5/1994	Takato et al.	370/110.1
5,541,957	7/1996	Lau	375/258

17 Claims, 3 Drawing Sheets

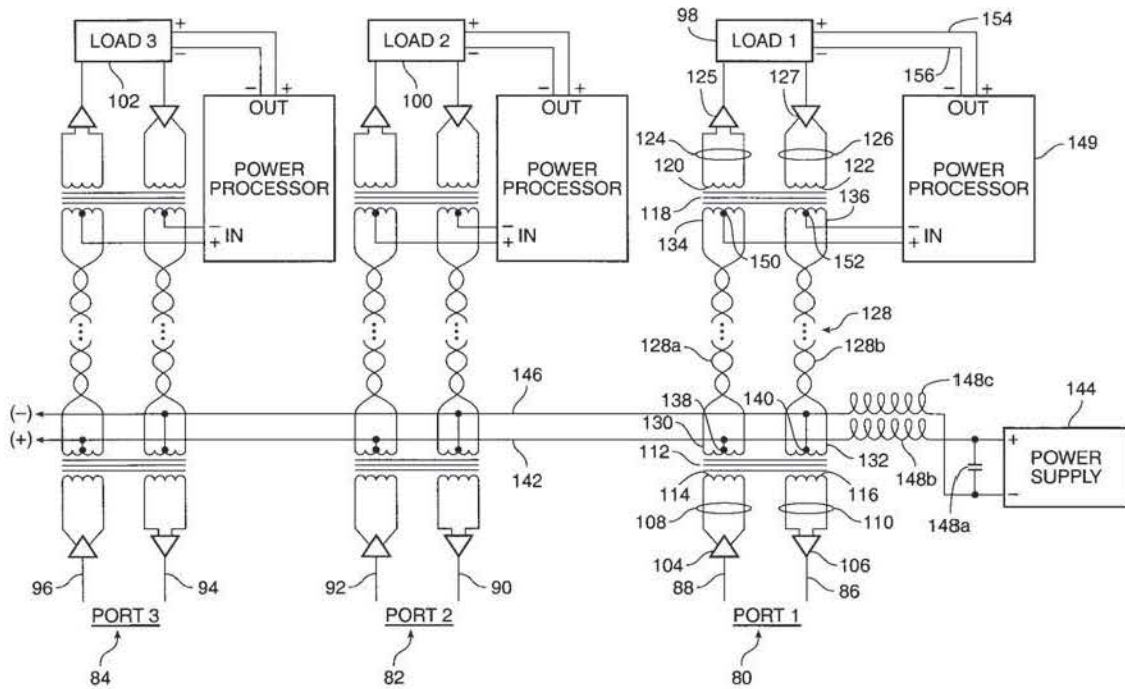

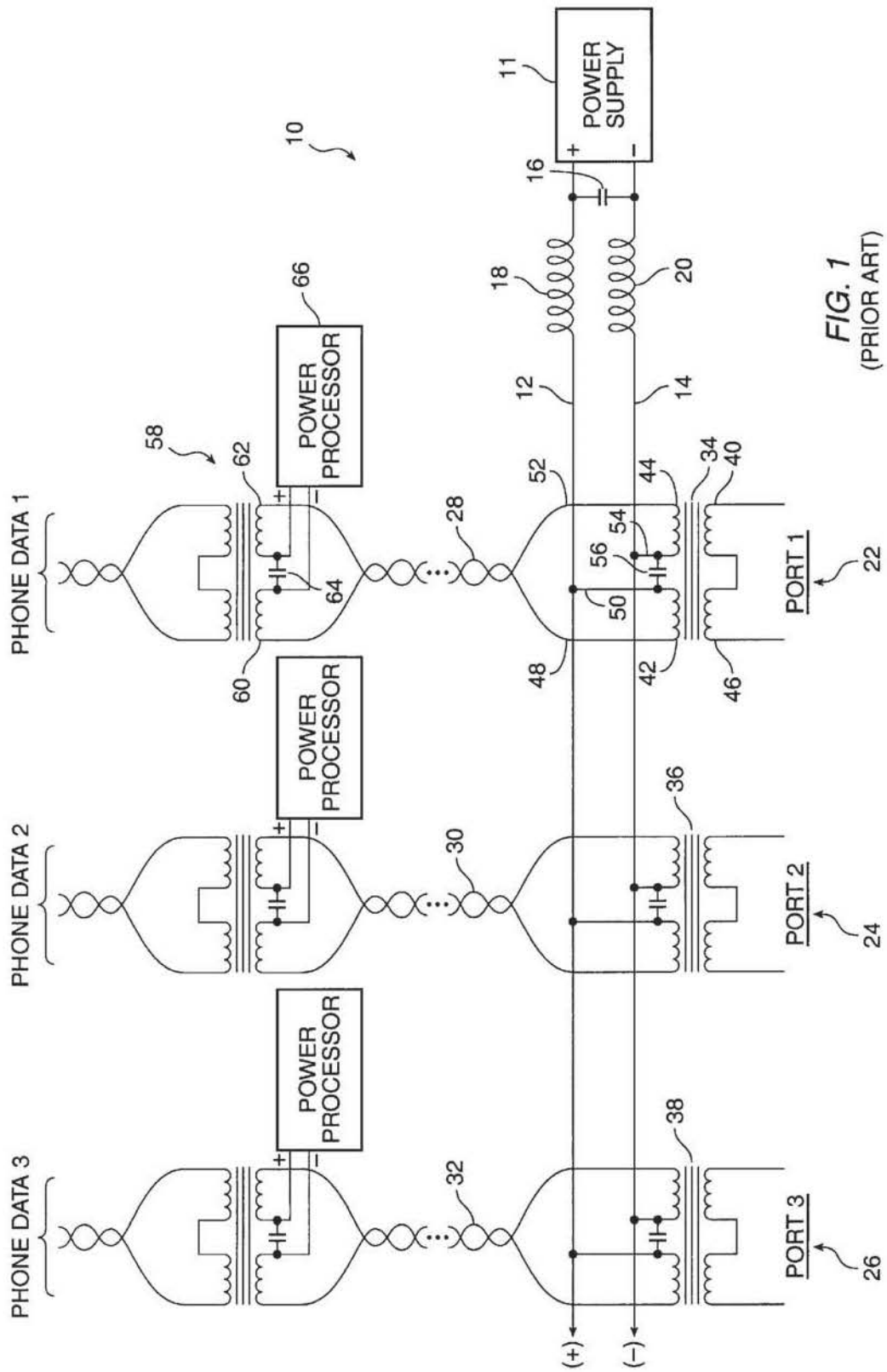

FIG. 1
(PRIOR ART)

66

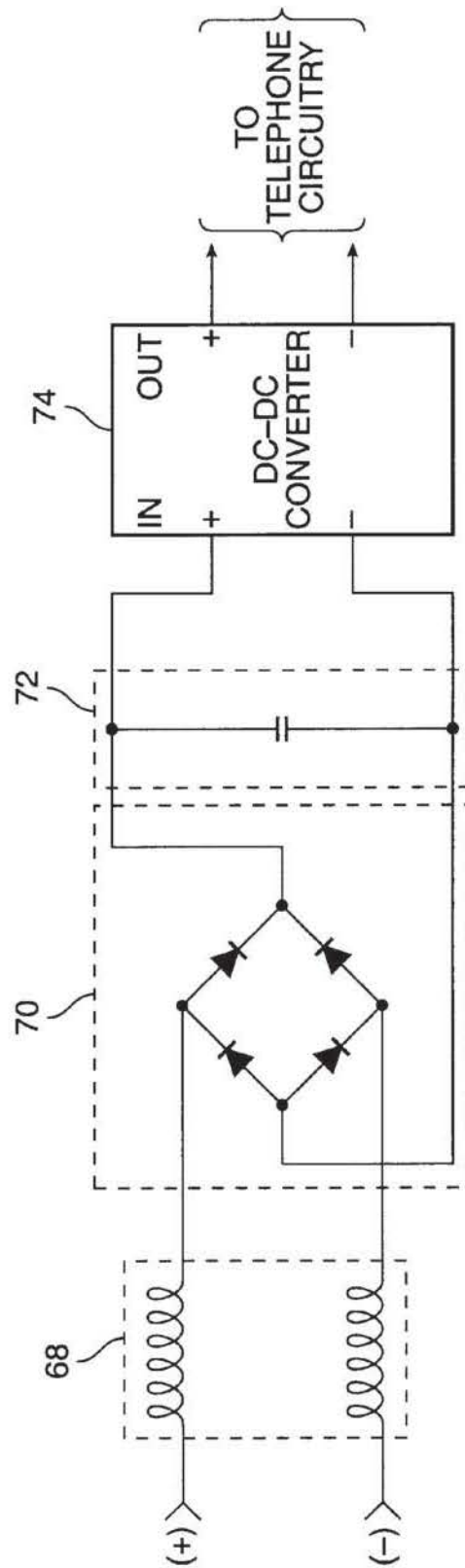

FIG. 2
(PRIOR ART)

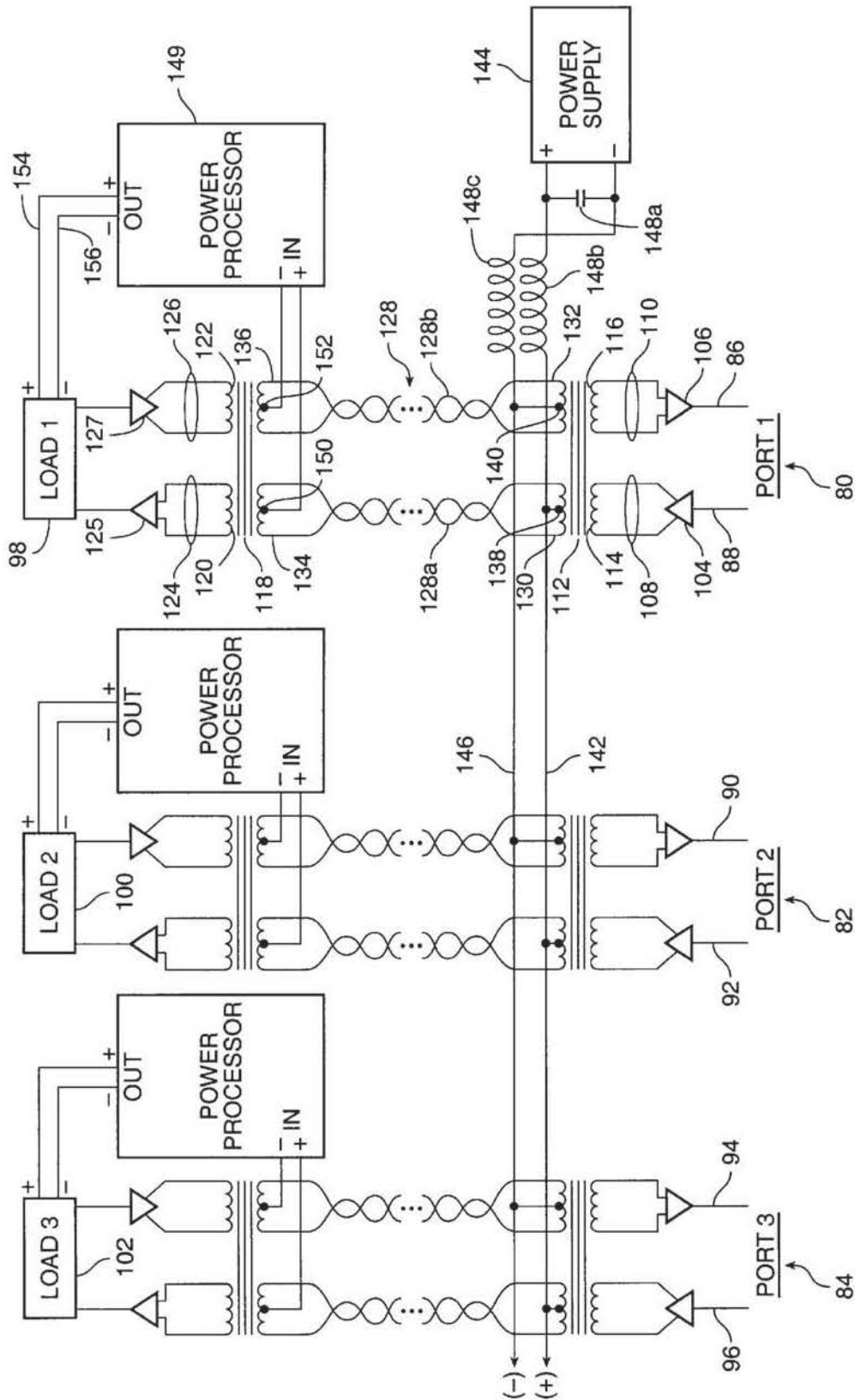

FIG. 3

POWER FEED FOR ETHERNET TELEPHONES VIA ETHERNET LINK

BACKGROUND OF THE INVENTION

1. Field of the Invention

The present invention is directed to a method and apparatus which provide electrical power to ethernet-based telephones over an ethernet wire link.

2. The Background Art

Telephones require electrical power in order to operate. The power can be delivered over the telephone lines or via a separate power connection, typically through a power transformer connected to the electrical power grid. Telephones powered in the latter fashion will be inoperable during a power failure unless provision is made both locally at the telephone and at the PBX or local telephone switch for emergency power to be supplied. While it is normal to provide an uninterruptible power supply to an office's PBX or telephone switch, it is not desirable for cost and other reasons to provide electrical power back up systems to each telephone location. In the past, the power problem was frequently solved by using an 8-wire telephone connection to the telephone switch. With 8 wires there is more than enough capability for analog audio digital and power connections to the telephone switch.

The growth of the Internet and similar local and wide area networks based on Ethernet technology has created a potential market for telephone systems which would connect directly to existing Ethernet connections. The Ethernet protocol, however, does not provide a mechanism for powering such telephones. A typical Ethernet connection to an office location would include a pair of unshielded twisted pair (UTP) lines for a total of four conductors—one pair for transmit, one for receive. The transmit pair is dedicated to send packets of data over the Ethernet connection; the receive pair receives packets of data over the Ethernet connection. Simply placing a DC bias on two or more of these conductors and using the bias to power a local Ethernet telephone is risky because the bias is not part of the Ethernet protocol and might damage Ethernet compliant equipment not designed to handle such a bias.

Turning to FIGS. 1 and 2, a prior art scheme for providing power over a single twisted pair connection is shown. In the prior art, system 10 and power supply 11 provides DC power over lines 12 (positive lead) and 14 (negative lead) to a series of ports on the network. Filter capacitor 16 and filter inductors 18 and 20 are preferably provided to insure a clean source of DC power and to avoid AC cross-talk between the network and the power supply. Each port 22, 24 and 26 of the network is coupled to a twisted pair link 28, 30 and 32, respectively, via a transformer, 34, 36, and 38, respectively. Transformer 34, for example, operates as follows: Data on port 1 (22) is applied to the primary 40 of transformer 34 and coupled to a pair of secondary winding 42, 44 of transformer 34 through transformer core 46 in a conventional manner. One end 48 of secondary winding 42 is connected to twisted pair 28 and the other end 50 of secondary winding 42 is connected to the positive lead 12 of power supply 11. One end 52 of secondary winding 44 is connected to twisted pair link 28 and the other end 54 of secondary winding 44 is connected to the negative lead 14 of power supply 11. Leads 50 and 54 are AC-coupled to one another with capacitor 56 as shown. This blocks DC current from flowing and allows a DC bias to be established over the two conductors of twisted pair link 28 while simultaneously allowing the flow of data over the link.

At the telephone end of the twisted-pair link 28, a similarly structured transformer 58 receives the data signal as well as the DC bias. First primary 60 and second primary 62 are AC-coupled with capacitor 64 so as to be able to couple data signals from twisted-pair link 28 with transformer 58 while holding off a DC bias. The DC bias of twisted-pair link 28 is applied to a power processor 66 and from there provides to local equipment to be powered by the twisted pair system. A typical embodiment of a power processor 66 is shown in FIG. 2. It comprises a filter 68, a rectifier 70, a filter capacitor 72 and a DC-DC converter 74.

While fit for its intended purpose, the above-described system has some drawbacks which make it a less than ideal choice for an Ethernet environment. For example, each secondary 42 and 44 of transformer 34 and each primary 60 and 62 of transformer 58 will experience a net current flow equal to the total amount of current drawn by the load at the distal end of the twisted-pair link. This current will affect the choice of transformer core size at each end of the link and will affect the choice of wire gauge used for the link.

It would be desirable to provide an improved method and apparatus for powering Ethernet telephones over a 4-wire link. Such a system would be able to take advantage of existing wiring without the need to rewire the premises to install such devices. Furthermore, by providing power over the Ethernet connection, power transformers are not required at the device location, and a central uninterruptible power supply is made possible to provide power to the entire telephone system in case of a power failure.

SUMMARY OF THE INVENTION

An Ethernet device power transmission system provides electrical power to devices such as Ethernet telephones and related equipment over a 4-wire Ethernet connection without any need for rewiring premises having an existing 4-wire Ethernet system. The system eliminates any requirement for local power such as transformers to power such equipment as all power can be provided over the existing Ethernet wiring. A central uninterruptible power supply (UPS) is thereby made possible to provide back-up power to all such equipment. The system includes an input transformer, an output transformer and a pair of twisted pair conductors. The input transformer includes a pair of primaries for connection to a source of Ethernet data. The input transformer also includes a pair of secondaries, each having a center-tap. A first twisted pair conductor is connected across the first secondary, a second twisted pair conductor is connected across the second secondary and a DC-bias is provided between the respective center taps of the first and second secondaries. At the local end, the output transformer includes a first and second center-tapped primary and a first and second secondary for connection to the load device. The first and second primary center taps are connected to a power processor for extraction of DC power.

BRIEF DESCRIPTION OF THE DRAWINGS

FIG. 1 is an electrical schematic diagram of a prior art telephone power distribution system for use over a two-wire twisted pair system.

FIG. 2 is an electrical schematic diagram of a prior art telephone power extraction system or power processor.

FIG. 3 is an electrical schematic diagram of an Ethernet telephone power distribution system according to a presently preferred embodiment of the present invention.

DESCRIPTION OF THE PREFERRED EMBODIMENTS

Those of ordinary skill in the art will realize that the following description of the present invention is illustrative

Explore Litigation Insights

Docket Alarm provides insights to develop a more informed litigation strategy and the peace of mind of knowing you're on top of things.

Real-Time Litigation Alerts



Keep your litigation team up-to-date with **real-time alerts** and advanced team management tools built for the enterprise, all while greatly reducing PACER spend.

Our comprehensive service means we can handle Federal, State, and Administrative courts across the country.

Advanced Docket Research



With over 230 million records, Docket Alarm's cloud-native docket research platform finds what other services can't. Coverage includes Federal, State, plus PTAB, TTAB, ITC and NLRB decisions, all in one place.

Identify arguments that have been successful in the past with full text, pinpoint searching. Link to case law cited within any court document via Fastcase.

Analytics At Your Fingertips



Learn what happened the last time a particular judge, opposing counsel or company faced cases similar to yours.

Advanced out-of-the-box PTAB and TTAB analytics are always at your fingertips.

API

Docket Alarm offers a powerful API (application programming interface) to developers that want to integrate case filings into their apps.

LAW FIRMS

Build custom dashboards for your attorneys and clients with live data direct from the court.

Automate many repetitive legal tasks like conflict checks, document management, and marketing.

FINANCIAL INSTITUTIONS

Litigation and bankruptcy checks for companies and debtors.

E-DISCOVERY AND LEGAL VENDORS

Sync your system to PACER to automate legal marketing.