



US005768533A

United States Patent [19]

[11] Patent Number: **5,768,533**

Ran

[45] Date of Patent: **Jun. 16, 1998**

[54] VIDEO CODING USING SEGMENTED FRAMES AND RETRANSMISSION TO OVERCOME CHANNEL ERRORS

[75] Inventor: Xiaonong Ran, Cupertino, Calif.

[73] Assignee: National Semiconductor Corporation, Santa Clara, Calif.

[21] Appl. No.: 522,688

[22] Filed: Sep. 1, 1995

[51] Int. Cl.⁶ G01D 1/16

[52] U.S. Cl. 395/200.77; 395/181

[58] Field of Search 364/514 R, 715.02; 371/32, 34, 37.1, 37.7, 38.1, 39.1, 40.2, 41, 48, 55; 395/181, 182.04, 182.16, 182.19, 185.01, 185.05, 200.77; 382/309; 341/94

[56] References Cited

U.S. PATENT DOCUMENTS

Re. 31,182	3/1983	Crager et al.	178/3
4,829,524	5/1989	Yoshida	371/32
5,105,423	4/1992	Tanaka et al.	371/5.5
5,481,566	1/1996	Kulesa	375/259

OTHER PUBLICATIONS

Goodman, D. et al., "Combined Source and Channel Coding for Variable-Bit-Rate Speech Transmission", 62 *The Bell System Technical Journal* 2017-2035 (1983).

Primary Examiner—James P. Trammell
Assistant Examiner—Thomas Peeso
Attorney, Agent, or Firm—Skjerven, Morrill, MacPherson, Franklin & Friel; Edward C. Kwok; David T. Millers

[57] ABSTRACT

A communication system and protocol uses retransmission techniques for video transmission on mobile/wireless channels. The system partitions frames of a moving image into frame segments, and combines a sequence of frame segments to form a sub-sequence of the moving image. The sub-sequences are treated as separate images which are separately encoded and transmitted to a receiver and then are combined to reassemble the moving image. A sender transmits to the receiver data packets, each data packet representing all or part of a digital code for a frame segment. The receiver requests retransmission of data packets containing detectable errors, indicates in a status buffer which digital codes have been received and whether the digital codes are intra or inter codes, and displays a frame only after all required data packets have been received without detectable errors. The segmented frames limit occasional failures to accurately retransmit data to individual sub-sequences, so that the failure to accurately transmit data is compensated for by subsequent transmission an intra coded digital code for a frame segment.

21 Claims, 2 Drawing Sheets

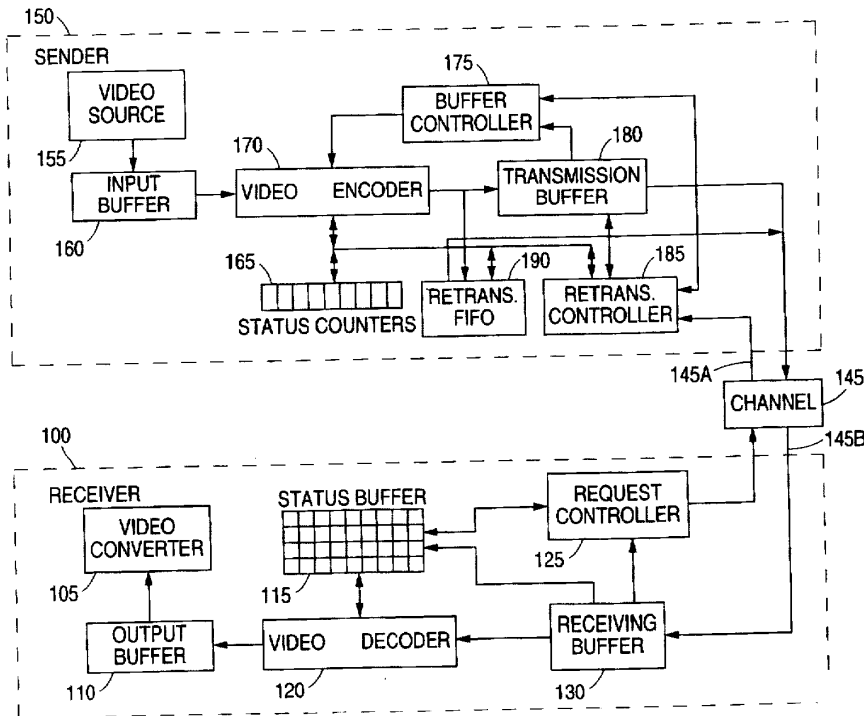

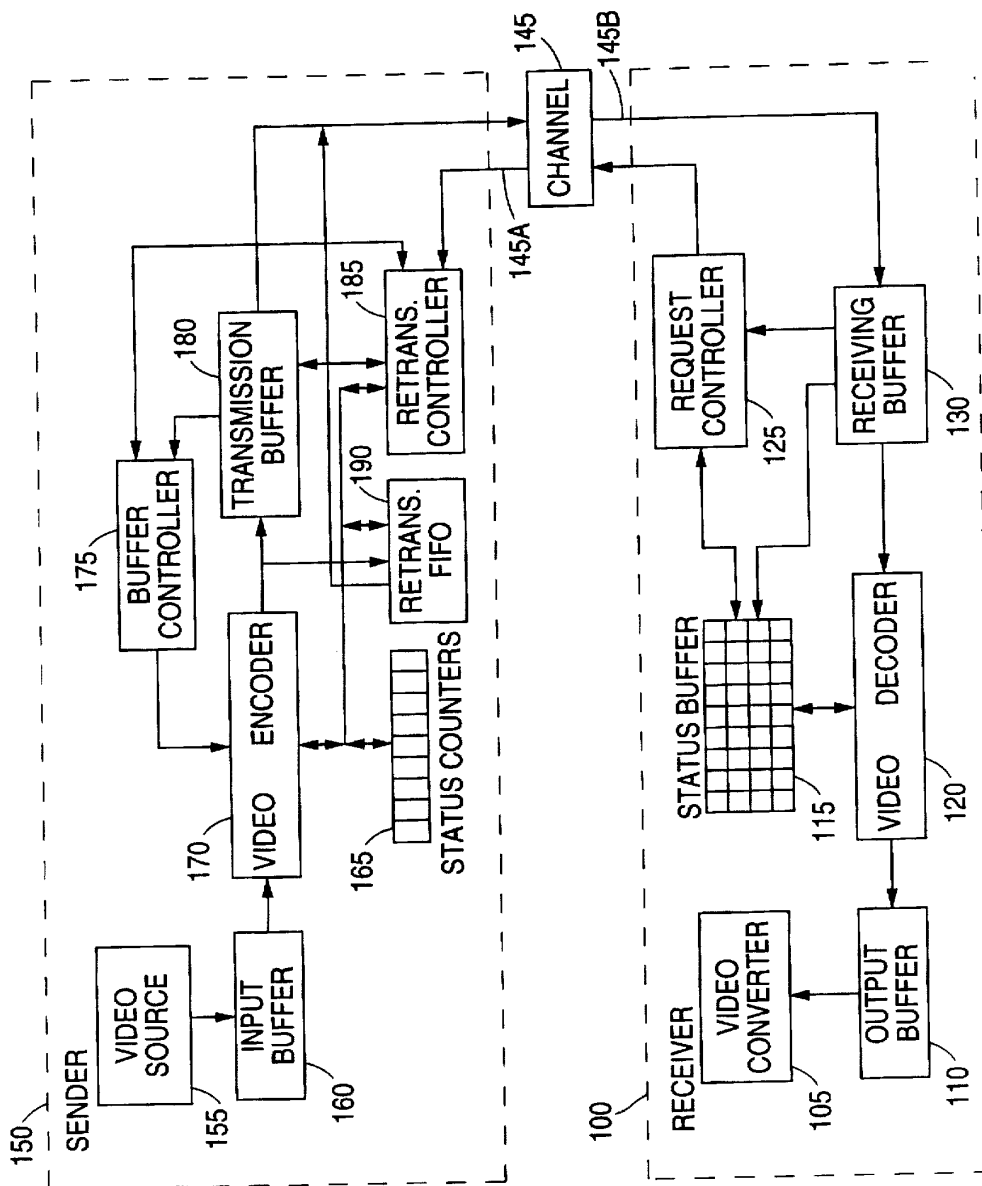
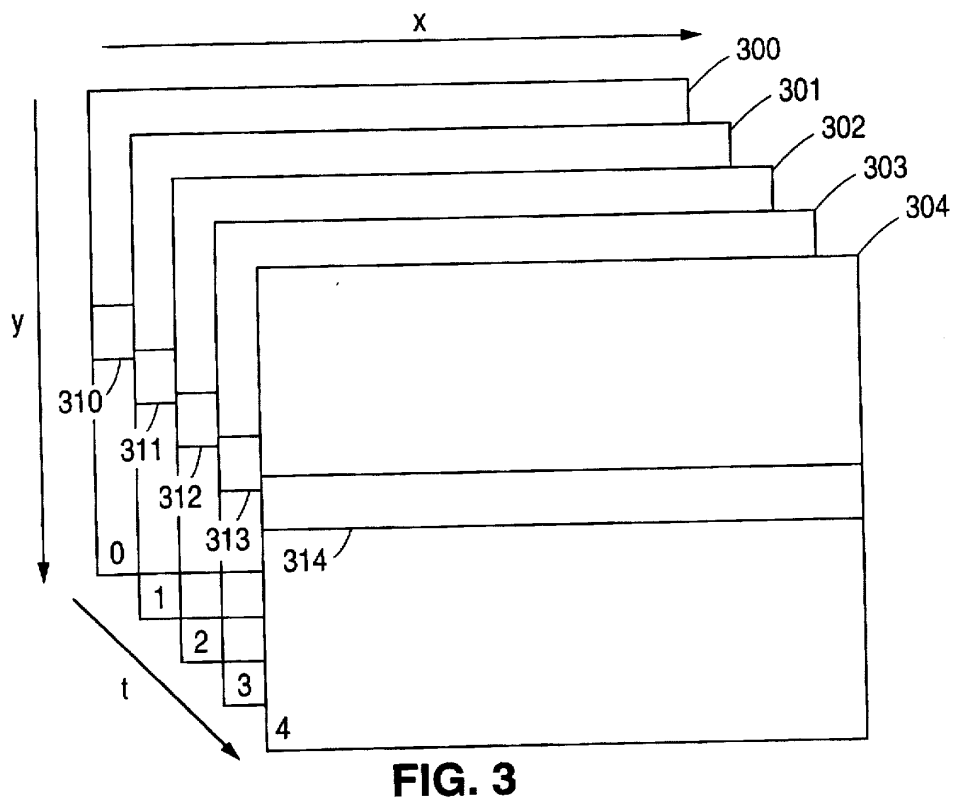
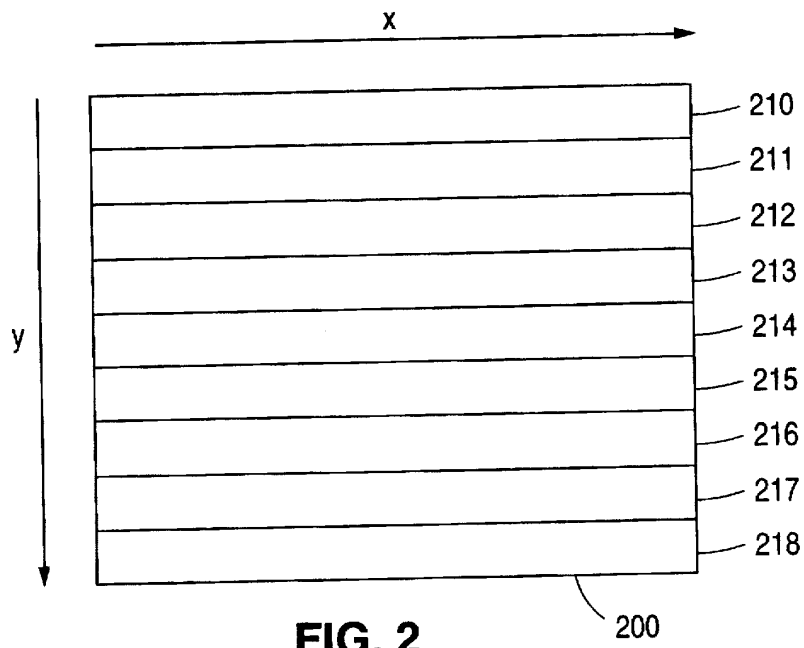

FIG. 1



VIDEO CODING USING SEGMENTED FRAMES AND RETRANSMISSION TO OVERCOME CHANNEL ERRORS

BACKGROUND OF THE INVENTION

1. Field of the Invention

This invention relates generally to coding, transmission, and display of video in telecommunication systems having bursty channel errors and in particular relates to mobile/wireless videophone systems.

2. Description of Related Art

Digital mobile/wireless telephones use mobile/wireless channels to transmit digital signals representing audio. Such signals are normally in the form of packets. More specifically, a sender transmits a signal representing packets of digital audio data where each packet represents 30 ms of audio; and a receiver decodes one packet every 30 ms to maintain continuous audio output. However, channel (or transmission) errors in the data packets can be as many as one bit in 10^3 to 10^2 which can interfere with the decoding process. Typically, channel errors for mobile/wireless telephone channels tend to be bursty, that is the errors occur in bursts or groups that are clumped together. Such burst of errors may correspond to events such as an object becoming temporarily interposed between the sender and receiver. To correct for the channel errors, the packets contain error correction codes (ECCs) with which the receiver attempts to correct the errors.

In some other types of data transmission systems, a receiver which detects errors in a data packet from a sender requests that the sender retransmit the data packet. A variety of retransmission strategies are available and include basic automatic repeat request (ARQ) and hybrid ARQ protocols. Examples of ARQ systems are described in "Error Control Coding: Fundamentals and Applications", by Shu Lin and Daniel J. Costello, Jr., copyright by Prentice-Hall, Inc. (1983) which is incorporated herein by reference in its entirety.

Retransmission is typically not used for mobile/wireless telephones because retransmission introduces unacceptable delay jitter into the audio. For instance, a receiver must receive packets representing 30 ms of audio at a rate of one per 30 ms. Otherwise, skips and breaks appear in the audio. Buffering or temporarily storing data packets in the receiver allows some flexibility in the timing of the data packets, but buffering delays generation of audio from the packet. If the delay is too large, it becomes noticeable to users and changes the pattern of telephone conversations. If the delay is small enough not to be noticed, there is insufficient time to allow the receiver to request and receive a retransmitted data packet before the data is needed for audio generation, especially if a data packet must be retransmitted more than once before being received without errors.

Accordingly, instead of retransmission, mobile/wireless telephones have used techniques such as algebraic error control coding for correction of channel errors and equal/unequal error protection coding to provide more error correction coding for the most critical data. With the error correction coding, retransmission is not required, and delay jitter caused by retransmission is avoided. Errors which cannot be corrected from the error correction codes cause static which is acceptable for most communications.

Recently, systems have been proposed for digital mobile/wireless videophones wherein a sender transmits signals representing both audio and video. The systems have

included error correction coding for video which is similar to the error correction coding used in mobile/wireless telephones. However, errors in video data which cannot be corrected by algebraic error correction result in video displayed with flawed areas containing incorrect colors and/or intensities. These flawed areas can be very noticeable and distracting. Additionally many of the most efficient video compression processes use encoding commonly referred to as "inter" coding. Inter coding encodes changes between successive frames of a moving image, and the receiver adds the inter coded data to data from a previous frame to determine a current frame of the moving image. Unfortunately, with inter coding, new inter coded data builds new frames on frames containing flaws, and the receiver may preserve and repeat flaws caused by an uncorrectable error. Further, uncorrectable errors can accumulate from several frames, resulting in poor image quality. Avoiding inter coding can prevent accumulation of flaws but typically decreases compression efficiency which decreases maximum frame rate and/or image quality. Accordingly, a system is needed which eliminates the flawed areas displayed by videophones and permits use of inter coding.

SUMMARY OF THE INVENTION

In accordance with the invention, a communication system such as a videophone system uses retransmission to correct channel errors in signals representing a moving image. Each frame of the moving image is displayed only after all necessary data for the frame has been received without errors that are detectable by a receiver. Accordingly, each frame of the moving image is displayed without flaws that commonly appear in systems using algebraic error correction.

In one embodiment of the invention, a moving image is spatially partitioned into sub-sequences which are sequences of frames segments, each frame segment being part of a frame of the moving image. Sub-sequences are encoded separately so that channel errors in one sub-sequence do not affect other sub-sequences. Typically, a sender inter codes frame segments for the sub-sequences and transmits digital codes representing the frame segments to a receiver. The receiver requests retransmission when an error is detected in a digital code representing a frame segment. However, if retransmission fails to provide error-free data for the frame segment in time for decoding, a subsequent frame segment in the sub-sequence is intra coded so that the data which could not be accurately transmitted is no longer necessary. Dividing the moving image into sub-sequences reduces the required intra coded data from an entire frame to a frame segment, and therefore improves average compression efficiency.

To reduce the amount of data affected by a burst of channel errors, each digital code representing a frame segment in a sub-sequence is divided into data packets which have a length dynamically set according to an error rate on a transmission channel. Typically, the length is set so that the chance of transmitting the packet without error is sufficiently high. In addition to dynamically setting the packet length according to an error pattern on the channel, the frame rate and quantization steps size used for encoding the moving image can be dynamically adjusted to provide maximum frame rate and image quality for the effective capacity of the channel.

To determine when a frame is ready for display, the receiver contains a status buffer which contains entries corresponding to the frame segments in several consecutive

frames. Each entry indicates whether a digital code for a frame segment has been received without errors and indicates whether the frame segment is inter or intra coded. A frame segment is considered displayable if the frame segment is intra coded and the code for the frame segment has been received without errors or if the frame segment is inter coded, the code for the frame segment has been received without errors, and the preceding frame segment in the same sub-sequence is displayable. A frame is displayable if all the frame segments in the frame are displayable. The receiver only displays the most recent displayable frame. Accordingly, some frames may be skipped which decreases the frame rate in the moving image. However, frame rate variation is less noticeable than the frame quality degradation common in other systems.

In accordance with another aspect of the invention, the sender contains status counters which correspond to the sub-sequences. The status counters contain counts indicating the number of times that frame segments in the sub-sequences have been inter coded. If any count exceeds a threshold, the next frame segment for the sub-sequence corresponding to the count is intra coded. This refreshes the data in the receiver and removes any flaws in the moving image caused by previous undetected channel errors.

BRIEF DESCRIPTION OF THE DRAWINGS

FIG. 1 shows a communication system in accordance with an embodiment of the invention.

FIG. 2 illustrates a moving image having an image area which is partitioned in accordance with an embodiment of the invention.

FIG. 3 represents frame segments in frames of a moving image.

DETAILED DESCRIPTION OF THE PREFERRED EMBODIMENTS

In accordance with an embodiment of the invention, a communications system includes a sender which transmits a series of video data packets to a receiver. The packets represent a sequence of frames which form a moving image. The receiver collects the packets from the sender and checks the packets for errors. When a packet is received without errors, the receiver sets an entry in a video status buffer to indicate that a packet for a particular portion of a frame is ready. When the receiver detects an error, the receiver requests that the sender retransmit the packet which contained the error.

The sender, in response to a retransmission request, immediately inserts the retransmitted video data packet into the series of packets transmitted to the receiver. Accordingly, the series of data packets may mix video data from different frames, and the video status buffer in the receiver contains entries for several frames to track data packets for the different frames. When entries in the video status buffer indicate all data needed for a frame has been received without errors, the frame is "displayable", i.e. ready to be decoded and/or displayed. The receiver periodically checks the video status buffer to determine if any frames are displayable. If one or more is displayable, the receiver decodes and displays the newest of the displayable frames.

Generally, frames are displayed without errors because each data packet required for each frame displayed is without detectable error. Accordingly, flawed areas in the displayed moving image are avoided. Further, inter coding can be used without flaws accumulating in a displayed

image. The video data packets are relatively small when compared to the data required to represent an entire frame, and usually a retransmitted packet is received in time to display a frame without a delay or a change in the frame rate. Occasionally, display of a frame may be skipped or delayed which reduces or causes jitter in the frame rate of the displayed moving image. However, the change in the frame rate still provides an acceptable moving image for most videophone applications where fast motion and a high frame rate are not required. Additionally, the use of inter coding can improve video compression efficiency and allow a higher maximum frame rate than possible systems using less efficient video compression. The higher maximum frame rate at least partially compensates for loss of frames.

FIG. 1 shows a block diagram of a sender 150 and a receiver 100 which communicate via a channel 145. In one embodiment of the invention, one of sender 150 and receiver 100 is in a mobile/wireless videophone, and the other of receiver 100 and sender 150 is in a public switched telephone network (PSTN) videophone. In other embodiments of the invention, sender 150 and receiver 100 are both in mobile/wireless videophones or both in PSTN videophones. FIG. 1 shows the portions of two videophones that are required for one-way video transmission. To allow two-way video transmission over channel 145, each videophone would contain a transmitting portion similar or identical to sender 150 and a receiving portion similar or identical to receiver 100.

Sender 150 receives an input video signal from a video source 155. The input video signal represents a sequence of frames where each frame is a still image. A time index orders the frames, and when displayed in sequence, the frames provide the illusion of an image containing moving objects. Thus, the sequence of frames are referred to herein as a moving image. Sender 150 encodes the moving image and transmits via channel 145 a signal representing the moving image.

In a mobile/wireless or PSTN videophone, video source 155 contains a video camera and an analog-to-digital converter capable of providing a digital signal representing a moving image. An input buffer 160 stores data representing the digital signal from video source 155. Data representing video can have a variety of formats. In one embodiment of the invention, each frame in the moving image is represented by one or more two-dimensional arrays of pixel values which are stored in input buffer 160. Each pixel value in a two-dimensional array represents an intensity, color, or color component for a small area or picture element having a position in a frame corresponding to the position of the pixel value in the two-dimensional array. For example, a frame can be represented by a single two-dimensional array of pixel values wherein each pixel value represents a set of three RGB or YUV color components which identify a color for a corresponding picture element. Alternatively, a frame can be represented by three arrays, one corresponding to each of three color components RGB or YUV.

FIG. 2 represents an image area 200 for a moving image. Image area 200 contains a two-dimensional array of picture elements (or pixels) which are represented by a two-dimensional array of corresponding pixel values. For example, in a format referred to in the art as QCIF, image area 200 is divided into 176×144 pixels which correspond to x co-ordinates ranging from 0 to 175 and y co-ordinates ranging from 0 to 143.

A time index t orders the frames of a moving image into a sequence as shown in FIG. 3. For a conventional video

Explore Litigation Insights

Docket Alarm provides insights to develop a more informed litigation strategy and the peace of mind of knowing you're on top of things.

Real-Time Litigation Alerts



Keep your litigation team up-to-date with **real-time alerts** and advanced team management tools built for the enterprise, all while greatly reducing PACER spend.

Our comprehensive service means we can handle Federal, State, and Administrative courts across the country.

Advanced Docket Research



With over 230 million records, Docket Alarm's cloud-native docket research platform finds what other services can't. Coverage includes Federal, State, plus PTAB, TTAB, ITC and NLRB decisions, all in one place.

Identify arguments that have been successful in the past with full text, pinpoint searching. Link to case law cited within any court document via Fastcase.

Analytics At Your Fingertips



Learn what happened the last time a particular judge, opposing counsel or company faced cases similar to yours.

Advanced out-of-the-box PTAB and TTAB analytics are always at your fingertips.

API

Docket Alarm offers a powerful API (application programming interface) to developers that want to integrate case filings into their apps.

LAW FIRMS

Build custom dashboards for your attorneys and clients with live data direct from the court.

Automate many repetitive legal tasks like conflict checks, document management, and marketing.

FINANCIAL INSTITUTIONS

Litigation and bankruptcy checks for companies and debtors.

E-DISCOVERY AND LEGAL VENDORS

Sync your system to PACER to automate legal marketing.