



- [54] **MEMORY BUS ARBITER FOR A COMPUTER SYSTEM HAVING A DSP CO-PROCESSOR**
- [75] Inventors: **Michael J. Bowes**, Cupertino; **Farid A. Yazdy**, Belmont, both of Calif.
- [73] Assignee: **Apple Computer, Inc.**, Cupertino, Calif.
- [21] Appl. No.: **189,138**
- [22] Filed: **Jan. 28, 1994**
- [51] Int. Cl.⁶ **G06F 13/00**
- [52] U.S. Cl. **395/294; 395/293**
- [58] Field of Search **395/325, 425**

5,313,591 5/1994 Averill 395/325
 5,353,417 10/1994 Fuoco et al. 395/325

Primary Examiner—Jack B. Harvey
Assistant Examiner—David A. Wiley
Attorney, Agent, or Firm—Blakely, Sokoloff, Taylor & Zafman

[57] **ABSTRACT**

An arbitration scheme for a computer system in which a digital signal processor resides on the computer system's memory bus without requiring a block of dedicated static random access memory. An arbitration cycle is divided into 10 slices of which 5 slices are provided in each arbitration loop to the digital signal processor. Two slices are provided each to the system's I/O interface and to the peripheral bus controller. A final slice is provided to the system's CPU. A default state when no memory bus resource is requesting the system memory bus parks the memory bus on the CPU. The arbitration scheme provides sufficient bandwidth for real-time signal processing by the digital signal processor operating from the system's dynamic random access memory while also providing sufficient bandwidth for a local area network interface through the system's I/O interface.

[56] **References Cited**

U.S. PATENT DOCUMENTS

4,641,238	2/1987	Kneib	395/325
4,928,234	5/1990	Kitamura et al.	395/425
4,987,529	1/1991	Craft et al.	395/325
5,263,163	11/1993	Holt et al.	395/325
5,301,282	4/1994	Amini et al.	395/325

8 Claims, 5 Drawing Sheets

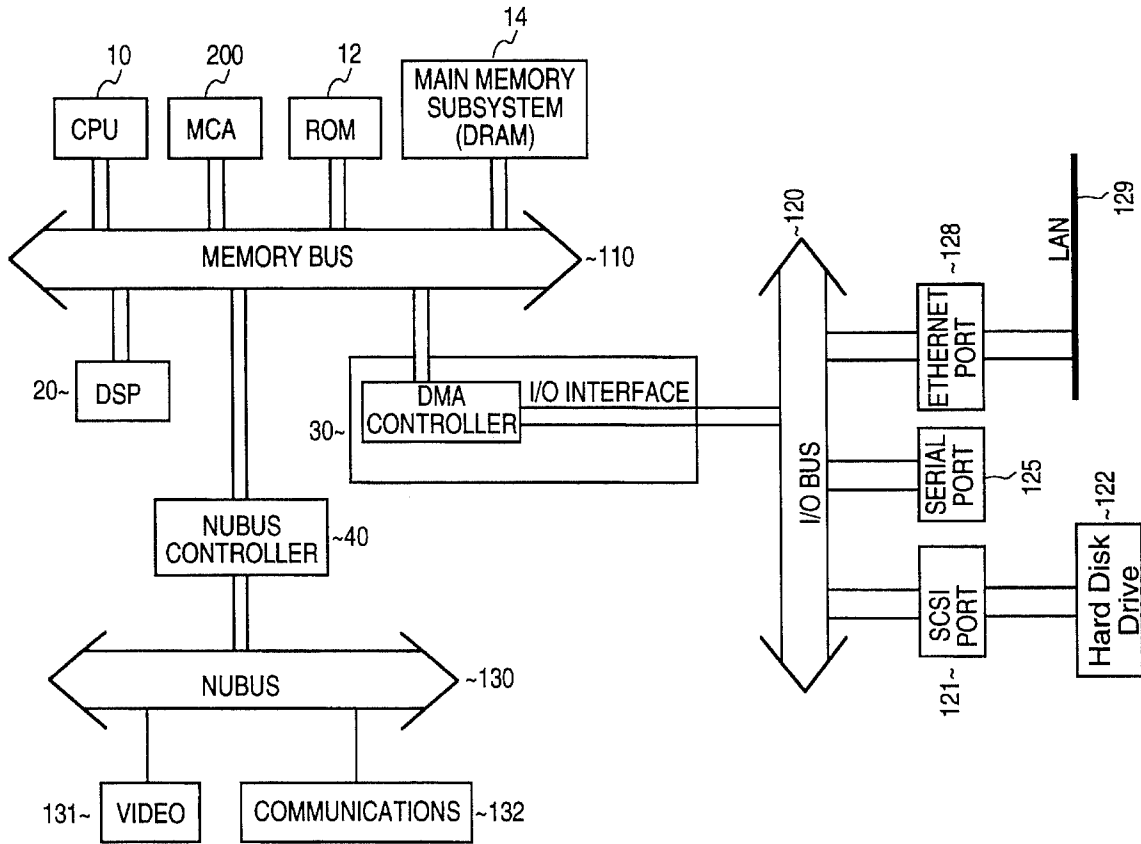

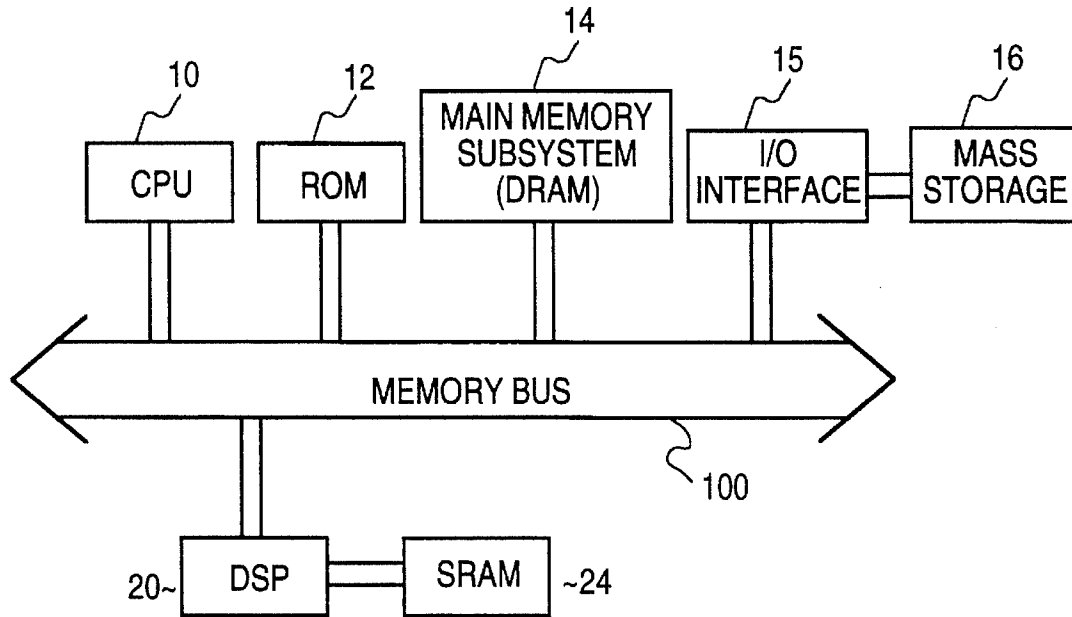

Figure 1 (Prior Art)

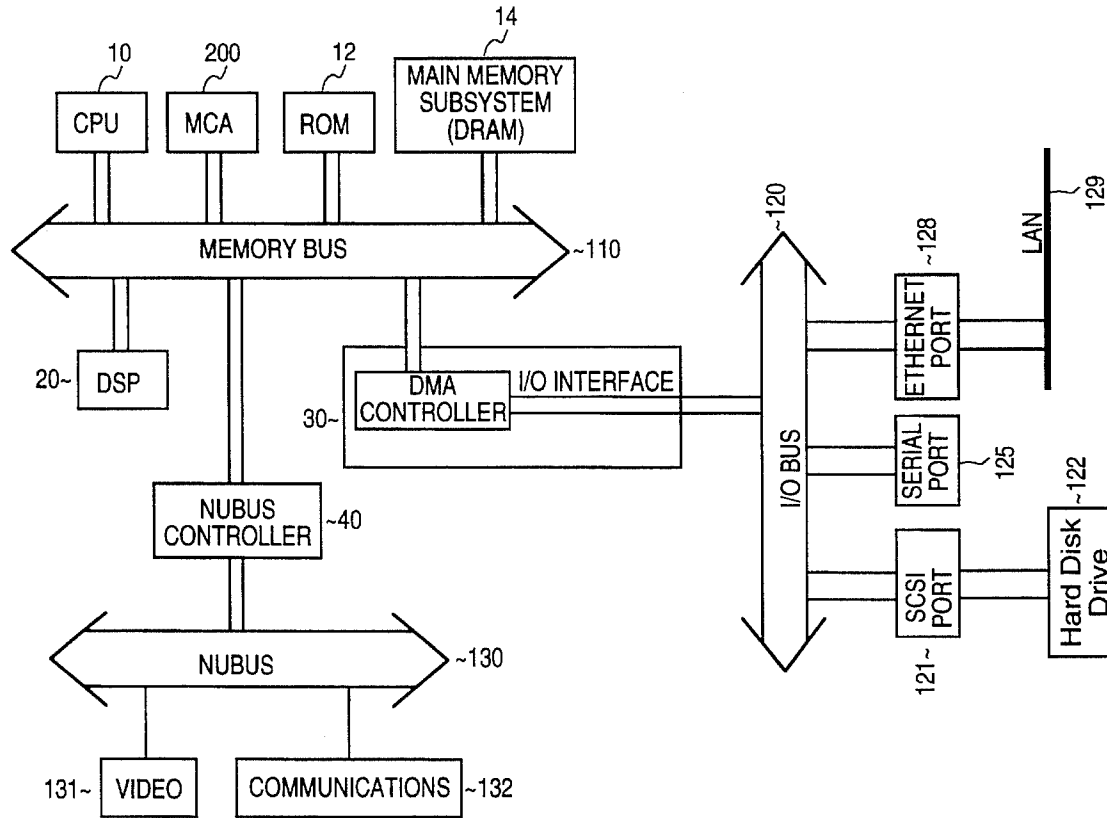

Figure 2

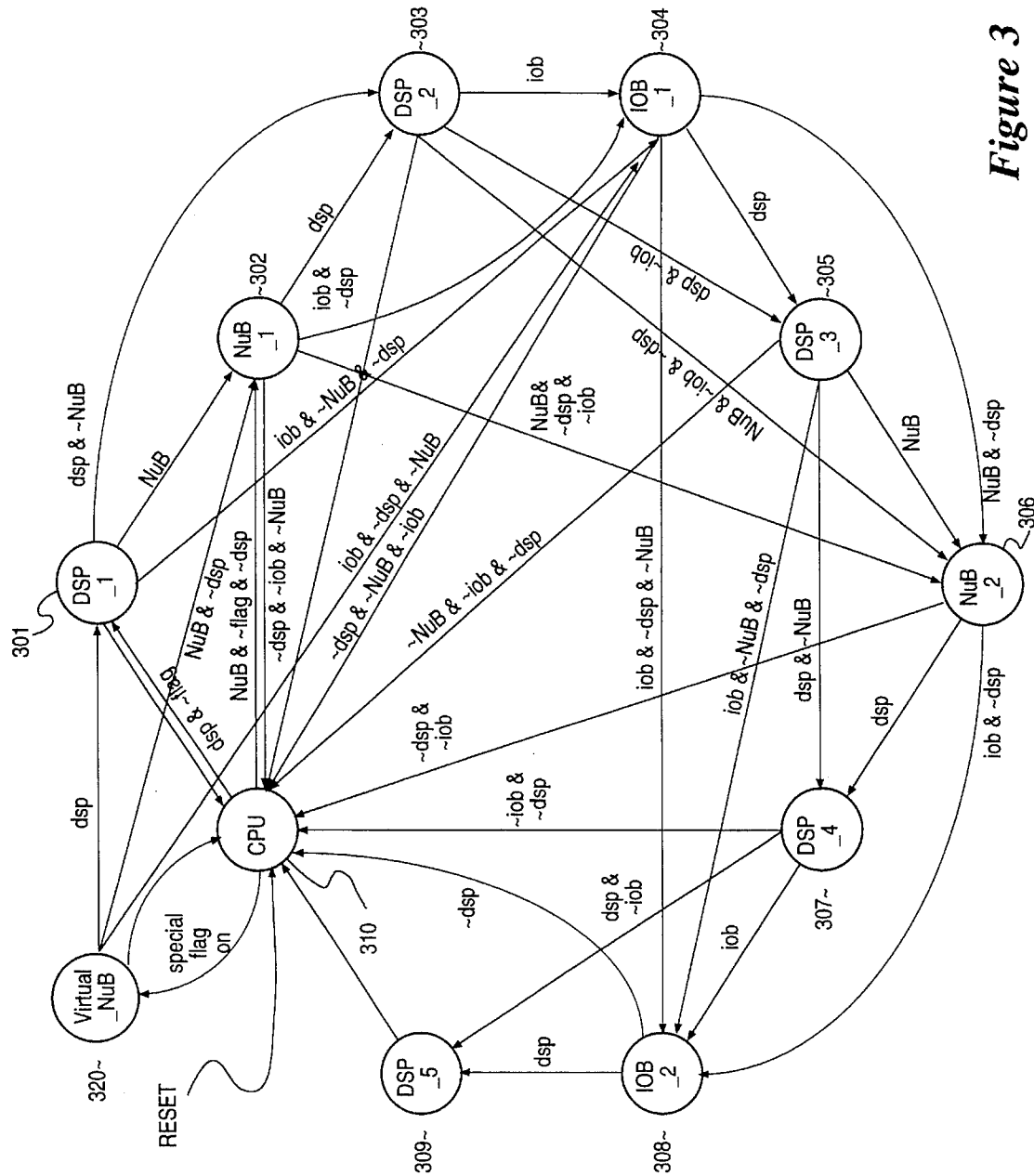

Figure 3

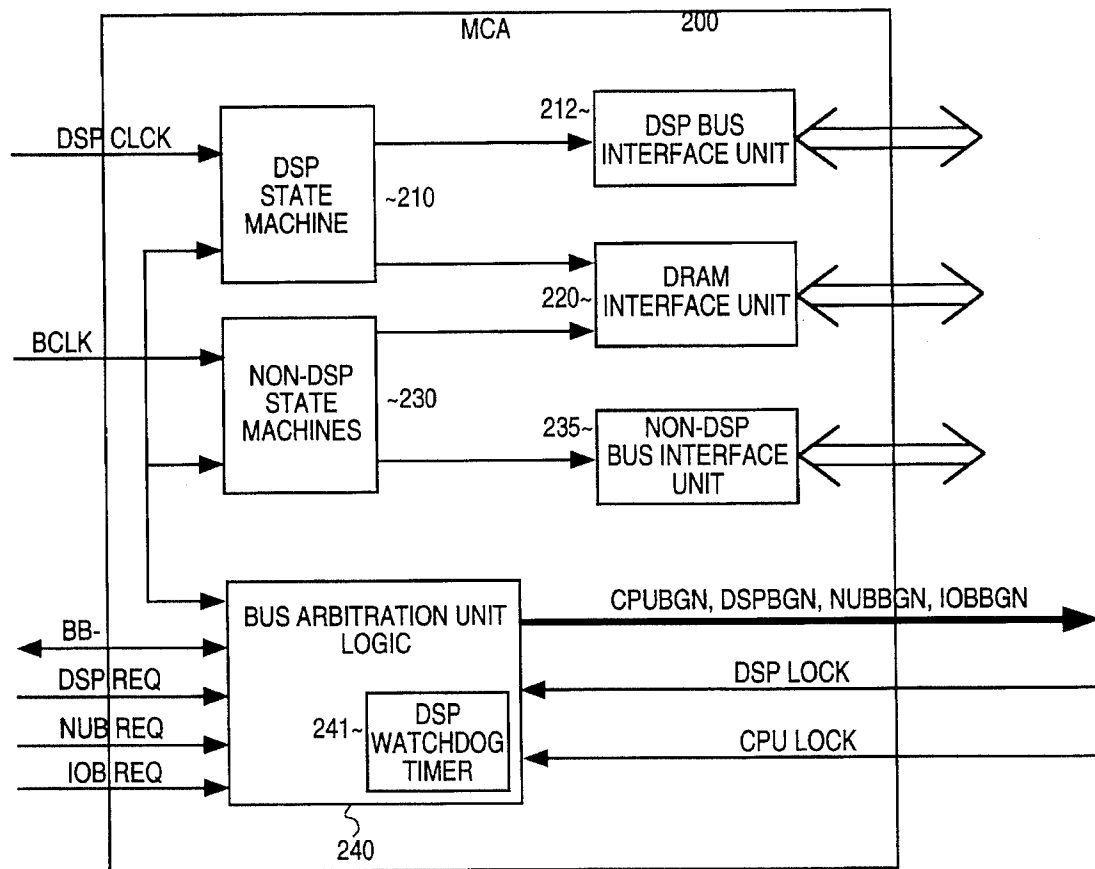

Figure 4

Explore Litigation Insights

Docket Alarm provides insights to develop a more informed litigation strategy and the peace of mind of knowing you're on top of things.

Real-Time Litigation Alerts



Keep your litigation team up-to-date with **real-time alerts** and advanced team management tools built for the enterprise, all while greatly reducing PACER spend.

Our comprehensive service means we can handle Federal, State, and Administrative courts across the country.

Advanced Docket Research



With over 230 million records, Docket Alarm's cloud-native docket research platform finds what other services can't. Coverage includes Federal, State, plus PTAB, TTAB, ITC and NLRB decisions, all in one place.

Identify arguments that have been successful in the past with full text, pinpoint searching. Link to case law cited within any court document via Fastcase.

Analytics At Your Fingertips



Learn what happened the last time a particular judge, opposing counsel or company faced cases similar to yours.

Advanced out-of-the-box PTAB and TTAB analytics are always at your fingertips.

API

Docket Alarm offers a powerful API (application programming interface) to developers that want to integrate case filings into their apps.

LAW FIRMS

Build custom dashboards for your attorneys and clients with live data direct from the court.

Automate many repetitive legal tasks like conflict checks, document management, and marketing.

FINANCIAL INSTITUTIONS

Litigation and bankruptcy checks for companies and debtors.

E-DISCOVERY AND LEGAL VENDORS

Sync your system to PACER to automate legal marketing.