



US008594298B2

(12) **United States Patent**
Klein et al.

(10) **Patent No.:** **US 8,594,298 B2**
(45) **Date of Patent:** **Nov. 26, 2013**

(54) **CALL MANAGEMENT**

(75) **Inventors:** **Mark D. Klein**, Los Altos, CA (US); **Michael Scott Manzo**, San Francisco, CA (US); **Tamara Hills Mahmood**, Cupertino, CA (US); **Andrew M. Maurer**, San Jose, CA (US); **Michael J. Kolbly**, Milpitas, CA (US); **Ronald D. Stelter**, San Ramon, CA (US); **Douglas L. Brackbill**, Aptos, CA (US)

(73) **Assignee:** **Avaya Inc.**, Basking Ridge, NJ (US)

(*) **Notice:** Subject to any disclaimer, the term of this patent is extended or adjusted under 35 U.S.C. 154(b) by 2462 days.

(21) **Appl. No.:** **11/060,232**

(22) **Filed:** **Feb. 16, 2005**

(65) **Prior Publication Data**

US 2005/0201362 A1 Sep. 15, 2005

Related U.S. Application Data

(60) Provisional application No. 60/546,409, filed on Feb. 20, 2004.

(51) **Int. Cl.**
H04M 3/42 (2006.01)

(52) **U.S. Cl.**
USPC **379/211.02**; 379/212.01; 379/221.01; 455/417

(58) **Field of Classification Search**
USPC 379/211.02, 201.01, 220.01, 221.01; 455/417

See application file for complete search history.

(56) **References Cited**

U.S. PATENT DOCUMENTS

4,790,003 A * 12/1988 Kepley et al. 379/88.18
5,329,578 A 7/1994 Brennan et al.

5,793,859 A 8/1998 Matthews
5,802,160 A 9/1998 Kugell et al.
5,848,142 A 12/1998 Yaker
5,857,013 A * 1/1999 Yuc et al. 379/88.2
6,094,574 A * 7/2000 Vance et al. 455/415
6,151,507 A * 11/2000 Laiho et al. 455/466
6,246,871 B1 * 6/2001 Ala-Laurila 455/413
6,343,121 B1 * 1/2002 Infosino 379/215.01
6,381,320 B1 * 4/2002 Creamer et al. 379/201.01
6,385,584 B1 * 5/2002 McAllister et al. 704/275
6,389,114 B1 * 5/2002 Dowens et al. 379/52
6,466,783 B2 * 10/2002 Dahm et al. 455/414.2
6,574,319 B2 * 6/2003 Latter et al. 379/142.07
6,574,470 B1 * 6/2003 Chow et al. 455/417

(Continued)

FOREIGN PATENT DOCUMENTS

CA 2407801 A1 5/2003

OTHER PUBLICATIONS

Notification of Transmittal of the International Search Report or the Declaration, PCT/US05/05307, May 29, 2005, 4 pages.

Written Opinion of the International Searching Authority, PCT/US05/05307, Jun. 16, 2005, 17 pages.

(Continued)

Primary Examiner — MD S Elahee

(74) *Attorney, Agent, or Firm* — Kacvinsky Daisak PLLC; John Maldjian, Esq.; Alexander D. Walter, Esq.

(57) **ABSTRACT**

A personal call management system allows a user to specify how incoming telephone calls should be handled. The user can specify various parameters including modes, filters, schedules, and the like. Incoming calls are routed to a specified telephone number, or sent to voicemail, or otherwise disposed of. Users can change modes manually or can specify automatic mode selection based on time of date, day of week, location, and/or other factors.

33 Claims, 20 Drawing Sheets

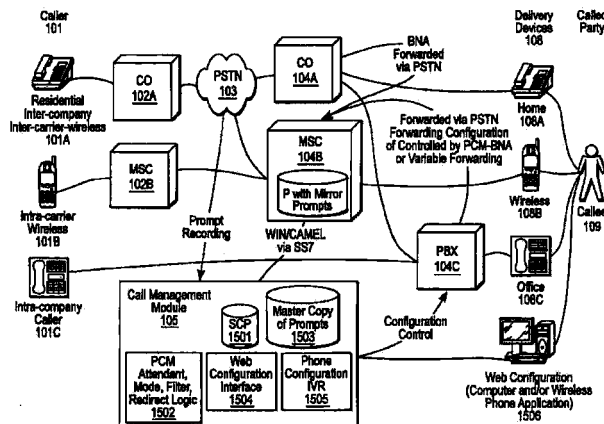

(56)

References Cited

OTHER PUBLICATIONS

U.S. PATENT DOCUMENTS

6,631,186	B1 *	10/2003	Adams et al.	379/201.12
6,768,792	B2 *	7/2004	Brown et al.	379/207.14
6,845,155	B2 *	1/2005	Elsey	379/266.04
7,330,721	B2 *	2/2008	Bhatia et al.	455/422.1
2002/0172347	A1 *	11/2002	Elsey	379/221.01
2003/0161459	A1 *	8/2003	McBlain et al.	379/220.01
2004/0028208	A1 *	2/2004	Carnazza et al.	379/221.01

Hyam, Kristy, "CA Application No. 2,556,892 Office Action Dec. 7, 2010", , Publisher: CIPO, Published in: CA.
Nash, Michael, "EP Application No. 05723332.2 Supplementary Search Report Apr. 12, 2011", , Publisher: EPO, Published in: EP.
Canadian Patent Application No. 2,556,892, "Call Management," Avaya Integrated Cabinet Solutions, Inc., Office Action dated Sep. 21, 2011, 4 pages.

* cited by examiner

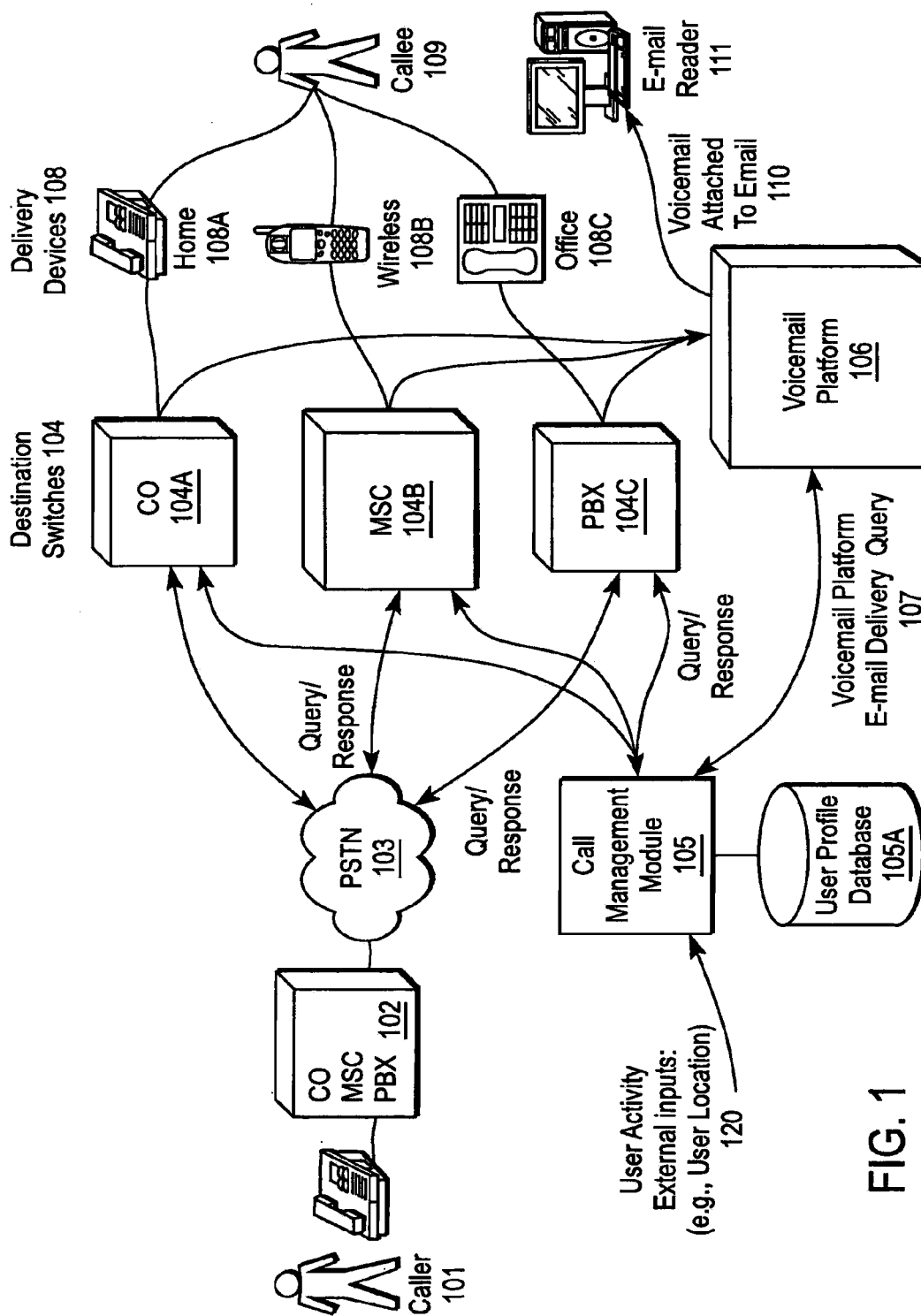

FIG. 1

CALL MANAGEMENT: EASY CALL DELUXE Step 1

How to Set it up

Step 1: Set Up Your Phones

Step 2: Set Up Your Call Manager

Step 3: Verification

Phone Set Up
Enter your phones and phone numbers so you calls are managed

Phone Set Up: Home phone: [650] [988] [1616] ~ 201A
Call management includes personal Voice mailbox for you. You may also add separate family Voice Mailbox (\$1.99/month)
 Add a Family Voice Mailbox (\$1.99/month)

Mobile phone: 850-714-2375 ~ 201B

Office phone: [408] [254] [2416] ~ 201C

Office phone (second helpline for business, vacation home, etc.)
 Description: [None] ~ 202 [] [] [] [] [] ~ 201D
Number: [] [] [] [] [] []

Block callers without caller ID ~ 203
 Enable my VIP List ~ 204
VIP's can always get a hold of you in case of emergency. Enter names and phone numbers in the VIP List manager (you can do this later).
 VIP List manager... ~ 205

Email address for call notification: [mklein@neubond.com] ~ 206
 Email Address for receiving voicemail: [mark.klein@neubond.com] ~ 207

Click Continue to move on, or Previous to go back

[Previous] ~ 208 [Continue] ~ 209

200 → FIG. 2

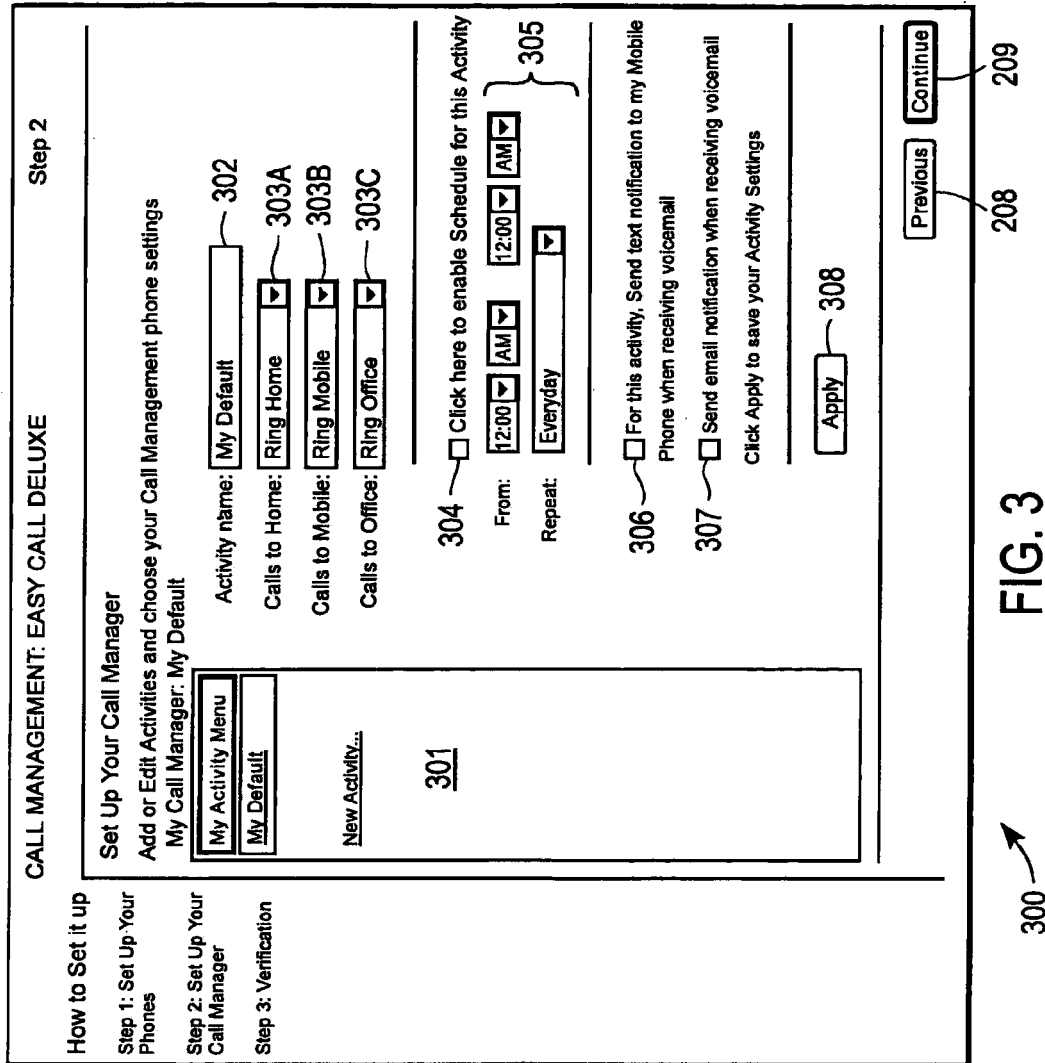

FIG. 3

Explore Litigation Insights

Docket Alarm provides insights to develop a more informed litigation strategy and the peace of mind of knowing you're on top of things.

Real-Time Litigation Alerts



Keep your litigation team up-to-date with **real-time alerts** and advanced team management tools built for the enterprise, all while greatly reducing PACER spend.

Our comprehensive service means we can handle Federal, State, and Administrative courts across the country.

Advanced Docket Research



With over 230 million records, Docket Alarm's cloud-native docket research platform finds what other services can't. Coverage includes Federal, State, plus PTAB, TTAB, ITC and NLRB decisions, all in one place.

Identify arguments that have been successful in the past with full text, pinpoint searching. Link to case law cited within any court document via Fastcase.

Analytics At Your Fingertips



Learn what happened the last time a particular judge, opposing counsel or company faced cases similar to yours.

Advanced out-of-the-box PTAB and TTAB analytics are always at your fingertips.

API

Docket Alarm offers a powerful API (application programming interface) to developers that want to integrate case filings into their apps.

LAW FIRMS

Build custom dashboards for your attorneys and clients with live data direct from the court.

Automate many repetitive legal tasks like conflict checks, document management, and marketing.

FINANCIAL INSTITUTIONS

Litigation and bankruptcy checks for companies and debtors.

E-DISCOVERY AND LEGAL VENDORS

Sync your system to PACER to automate legal marketing.