

- [54] **PUSH BUTTON SWITCH**
- [75] Inventor: **Jürgen Oelsch, Braunschweig, Germany**
- [73] Assignee: **Olympia Werke AG, Wilhelmshaven, Germany**
- [22] Filed: **Dec. 10, 1975**
- [21] Appl. No.: **639,607**
- [30] **Foreign Application Priority Data**
Dec. 20, 1974 Germany 2460485
- [52] U.S. Cl. **200/5 A; 200/67 DB; 200/159 A; 200/159 B; 200/275**
- [51] Int. Cl.² **H01H 13/70; H01H 1/06; H01H 21/02**
- [58] **Field of Search** 200/5 R, 5 A, 67 DA, 200/67 DB, 159 R, 159 A, 159 B, 275, 302, 329, 340, DIG. 1, 283, 292

3,917,917	11/1975	Murata	200/159 B X
3,928,736	12/1975	Drage	200/275 X
3,941,964	3/1976	Yoder	200/159 A
3,967,084	6/1976	Pounds	200/159 B X
3,969,600	7/1976	Sims, Jr.	200/5 A

Primary Examiner—James R. Scott
Attorney, Agent, or Firm—Spencer & Kaye

[57] **ABSTRACT**

A push button switch mounted on a conductor-carrying insulator plate includes a push button to which an external operating force can be applied; an electrically conducting, resilient switch element carrying a movable contact and arranged on the plate within the operating range of the push button for effecting at least an indirect transmission of the operating force to the switch element; and at least one fixed contact carried by the plate. In the operating position the movable contact is in engagement with the fixed contact. The switch element is constituted by a planar sheet member having a central zone bounded by two parallel edges and carrying the movable contact, and strip-like legs integral with the central zone and extending from the edges towards the insulator plate at an inclination with respect to the central zone that is greater than 90°. The legs are supported at least indirectly on the insulator plate at conductor-free portions thereof. Alternative embodiments include the use of a common sheet member having stamped flexible contact areas integral therewith incorporating the design features of the singular switch element.

- [56] **References Cited**
- UNITED STATES PATENTS**
- 3,710,209 1/1973 Webb et al. 200/DIG. 1
- 3,786,205 1/1974 Lien 200/275 X
- 3,796,843 3/1974 Durkee et al. 200/159 B X
- 3,800,104 3/1974 Lien et al. 200/67 DA
- 3,819,882 6/1974 Anderson et al. 200/159 A X
- 3,826,882 7/1974 Giolitti et al. 200/67 DA X
- 3,849,611 11/1974 Walker, Jr. 200/275 X
- 3,858,020 12/1974 Brannon 200/159 A
- 3,870,840 3/1975 Rivetta et al. 200/159 A X
- 3,899,648 8/1975 Murata 200/159 B X
- 3,911,233 10/1975 Nakamura et al. 200/159 B X
- 3,916,135 10/1975 Holden et al. 200/159 B X

25 Claims, 8 Drawing Figures

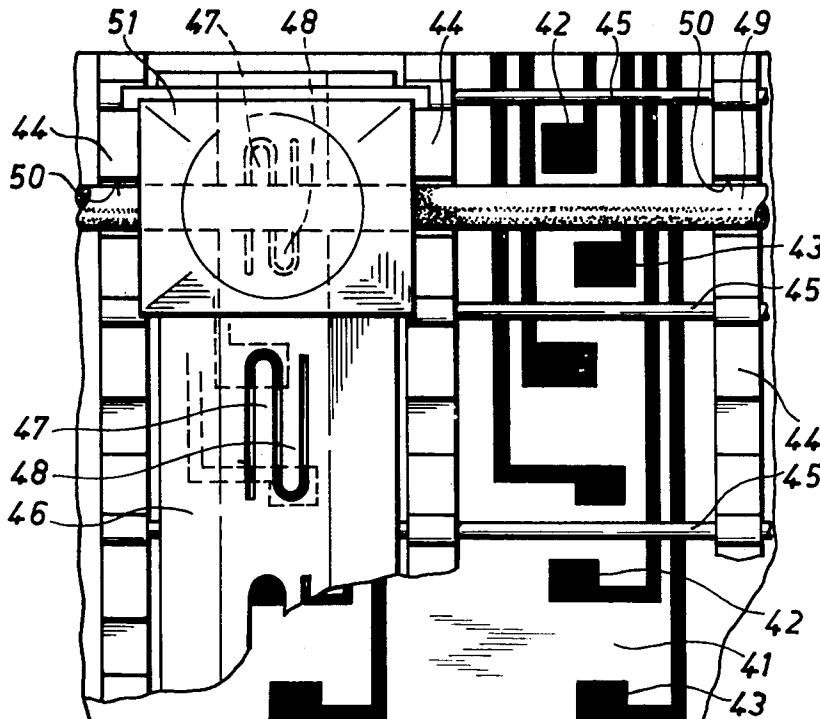

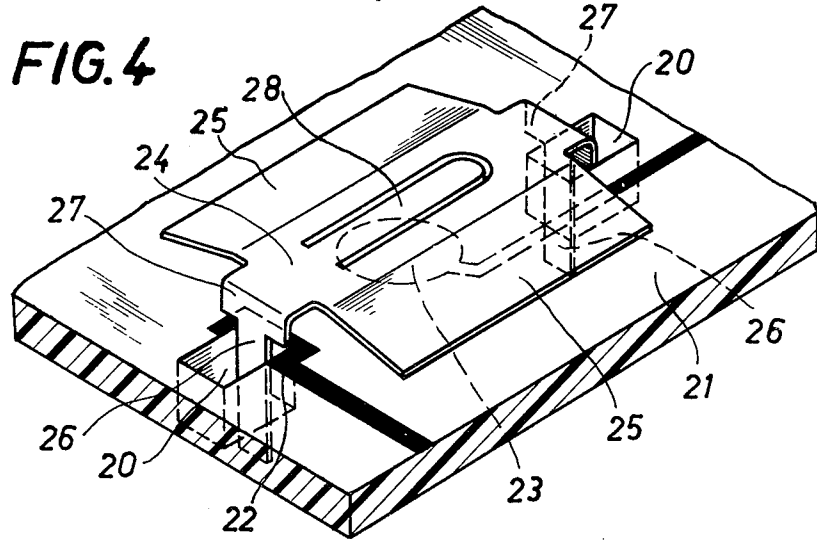
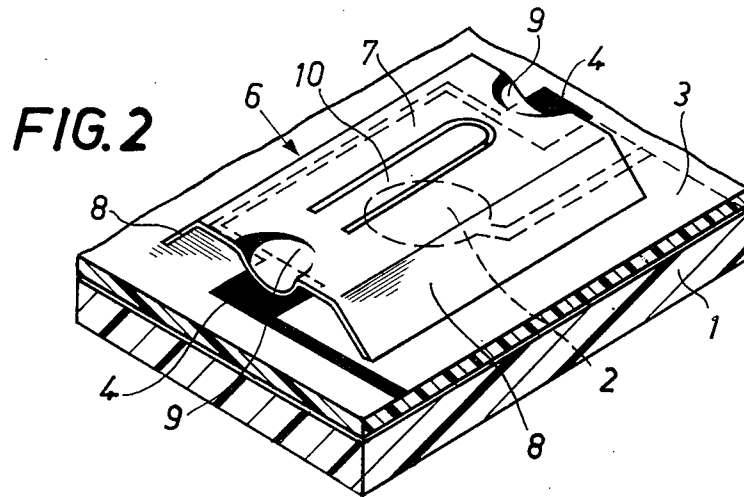
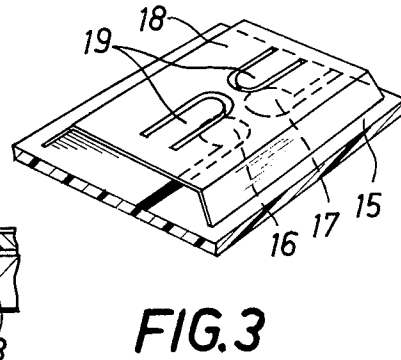
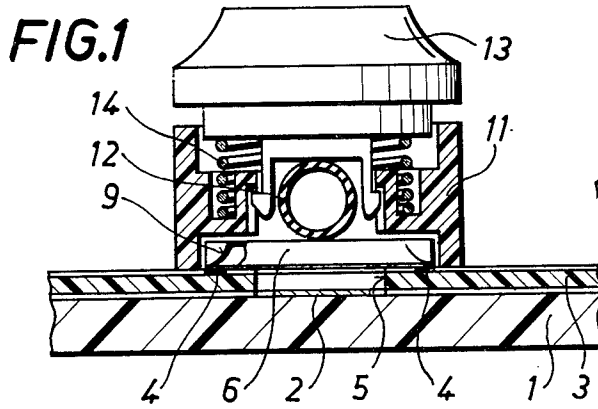

FIG. 6

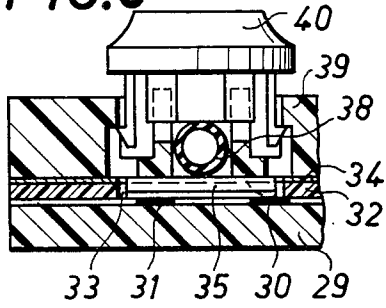

FIG. 5

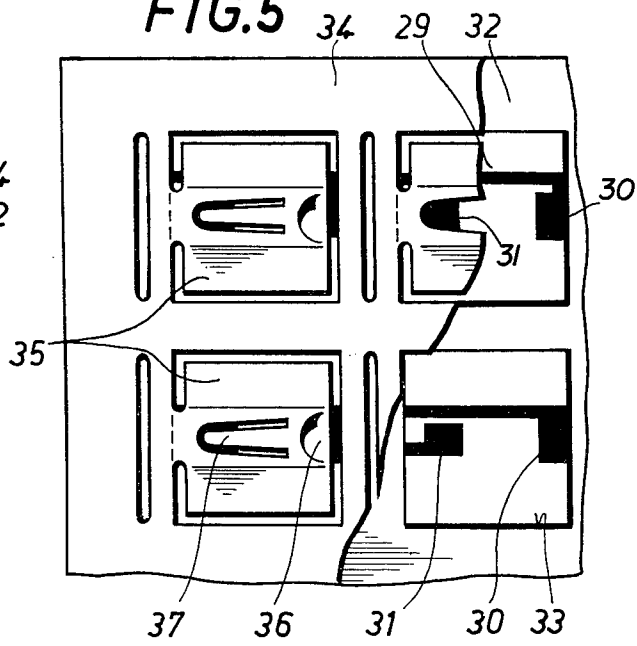

FIG. 7

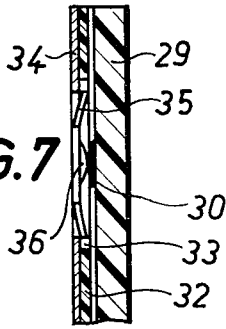
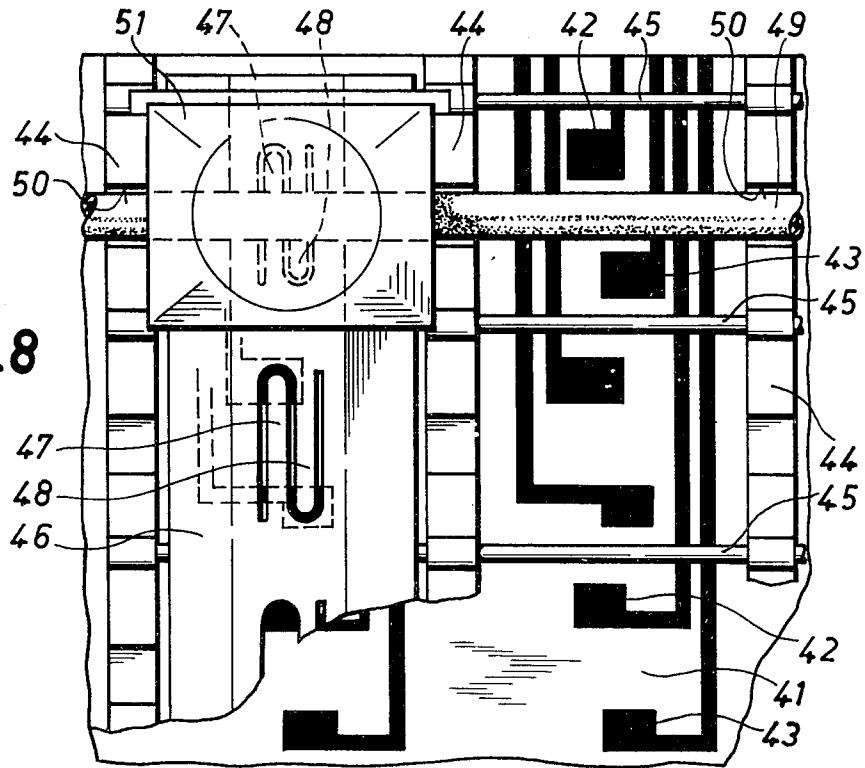

FIG. 8



PUSH BUTTON SWITCH

BACKGROUND OF THE INVENTION

The present invention relates to a push button switch for electrical and electronic devices comprising a push button and an electrically conducting elastic switch element which is caused by the push button to move rapidly, in a snap action, from a normal position into an operating position in which it contacts at least one fixed contact attached to a conductor-carrying insulator plate, such as a printed circuit board. When the force exerted on the push button is removed, the elastic switching element returns to its normal position.

Known push button switches of the above-outlined type are utilized as individual electrical switches or as a group in a planar arrangement, for example for data input in keyboards of electronic computers or electrical typewriters. The elastic, snap action switch elements are designed either as cup-shaped contact springs as disclosed, for example, in U.S. Pat. No. 2,262,777, or as two contact frames each having a bent central strip and two contact pieces and are thickened at two opposite lateral edges as disclosed, for example, in German Laid-Open Application (Offenlegungsschrift) No. 2,411,426. Cup-shaped contact springs, however, form a surface which cannot be developed and thus require increased manufacturing costs. The same applies for a contact frame which is shortened at opposite lateral edges, and the central strip of which thus assumes a curved shape. Moreover, such contact frame can be used merely as a single switch and not as a one-piece switch element for a plurality of push button switches arranged along a line or a plane.

SUMMARY OF THE INVENTION

It is an object of the present invention to improve a push button switch of the above-outlined type so that its snap action switch element has planar and thus developable surfaces for simplifying its manufacture.

This object and others to become more apparent as the specification progresses, are accomplished by the invention according to which, briefly stated, the push button switch mounted on a conductor-carrying insulator plate includes a push button to which an external operating force can be applied; an electrically conducting, resilient switch element carrying a movable contact and arranged on the plate within the operating range of the push button for effecting at least an indirect transmission of the operating force to the switch element; and at least one fixed contact carried by the plate. The switch element has a normal position which it assumes and maintains when no operating force is exerted thereon by the push button. In the normal position the movable contact is out of engagement with the fixed contact. The switch element further has an operating position which it assumes in snap action motion and maintains when the operating force exerted thereon by the push button reaches a certain magnitude. In the operating position, the movable contact is in engagement with the fixed contact. The switch element is constituted by a planar sheet member having a central zone bounded by two parallel edges and carrying the movable contact, and strip-like legs integral with the central zone and extending from the edges towards the insulator plate at an inclination with respect to the central zone that is greater than 90°. The

legs are supported at least indirectly on the insulator plate at conductor-free portions thereof.

The present invention makes it possible to manufacture a plurality of snap action switch elements in one piece without influencing one another when they are operated individually. The combination of a plurality of switch elements formed of a planar, laterally angularly bent sheet plate into a snap action contact strip or a one-piece snap action contact field, serves to provide a keyboard or a field of push buttons, respectively, at much less cost than previously possible while nevertheless entirely eliminating interference effects between the individually actuated movable contact elements.

BRIEF DESCRIPTION OF THE DRAWINGS

FIG. 1 is a sectional side elevational view of a first preferred embodiment of the invention.

FIG. 2 is a perspective view of one part of the first embodiment.

FIG. 3 is a perspective view of one part of a second preferred embodiment of the invention.

FIG. 4 is a perspective view of one part of a third preferred embodiment of the invention.

FIG. 5 is a fragmentary top plan view of one part of a fourth preferred embodiment of the invention illustrating the use of plural flexible contacts having a common sheet member.

FIG. 6 is a cross-sectional view of the fourth embodiment, including a push button.

FIG. 7 is a longitudinal sectional view of the fourth embodiment.

FIG. 8 is a top plan view of a fifth preferred embodiment of the invention having a different plural flexible contact configuration with a common sheet member.

DESCRIPTION OF THE PREFERRED EMBODIMENTS

Turning now to FIGS. 1 and 2, a lower conductor-carrying insulator plate, such as a lower printed circuit board 1 carries a fixed contact 2 which is one of the conductor lines. An upper conductor-carrying insulator plate, such as an upper printed circuit board 3, which is firmly connected to the lower printed circuit board 1, carries two electrically connected fixed contacts 4, likewise formed of conductor lines. The upper printed circuit board 3 is provided with an opening 5 (FIG. 1) in the area of the fixed contact 2. In case a plurality of push button switches are arranged on common boards 1 and 3, the latter are provided with a corresponding number of fixed contacts 2 and 4, while the upper board 3 is provided with the corresponding number of openings 5.

A switch element 6 disposed on the printed circuit board 3 is formed of a planar sheet of spring material (such as a resilient metal) which is bent angularly at its two longitudinal sides, so that the switch element has the shape of a flat roof as is clearly shown in FIG. 2. The switch element 6 thus comprises a flat center zone 7 and two longitudinal lateral strip-like legs 8 which are arranged at an obtuse angle with respect to the zone 7 and which are supported on insulating (i.e. conductor-free) portions of the board 3. Hump-like deformations 9 are pressed out of the center zone 7 at both ends of the switch element 6. An elongated U-shaped slot provided in the elevated, central zone 7 defines a contact tongue 10 which normally extends in the plane of the zone 7 and forms a portion thereof. The U-shaped slot may be made by etching or stamping.

As further seen in FIG. 1, there is provided a switch housing 11 which is permanently connected to the two printed circuit boards 1 and 3. The housing 11 positions the switch element 6 on the boards 1 and 3 so that the humps 9 are situated adjacent the fixed contacts 4 of the board 3 and the contact tongue 10 is positioned adjacent the fixed contact 2 of the board 1. The contact tongue 10 thus bridges the opening 5 in the board 3. An accumulator spring 12 of a rubber-elastic material and having a rod (preferably tube) shape, is arranged above the switch element 6 and is positioned by a push button 13 so that the longitudinal axis of the accumulator spring 12 extends at a right angle to the longitudinal dimension of the contact tongue 10. A reset spring 14 disposed between the switch housing 11 and the push button 13 assures that the push button 13 will return to its normal position when the force exerted thereon is removed.

The above-described push button switch according to FIGS. 1 and 2 operates as follows:

By applying an external force to the push button 13, the accumulator spring 12 as well as the reset spring 14 are compressed. During this occurrence the accumulator spring 12 is supported, by the switch element 6 or, more precisely, the strips 8, on the board 3. Moreover, the supporting hump-like deformations 9 which constitute movable contacts, arrive in electrically conducting engagement with the fixed contacts 4 of the board 3. A further increase in the force introduced and stored in the accumulator spring 12 effects a sudden snap action movement of the switch element 6 into a lower operating position in which the contact tongue 10 which constitutes a movable contact, extends downwardly and engages, through the opening 5 in the upper board 3, the fixed contact 2 of the lower board 1. In this operating position the switch element 6 acts in conjunction with the snapped-over contact tongue 10 as a contact bridge between fixed contacts 2 and 4. When the force acting on the push button 13 is removed, the elastic switch element 6 returns to its normal position in which the accumulator spring 12 and the push button 13 return to their respective positions of rest.

To simplify the switch structure, the reset spring 14 may be omitted. Its function is then performed by the accumulator spring 12. Instead of the two printed circuit boards 1 and 3 permanently attached to one another and each carrying conductors only on one face, it is feasible to use only one board provided with conductors either on one side or on both sides. Also, the tubular accumulator spring 12 which is made of a rubber-elastic material, may be replaced by a helical metal spring. It is to be understood that instead of printed conductors, the boards 1 or 3 may carry sheet metal conductor strips attached thereto.

Turning now to the embodiment illustrated in FIG. 3, a printed circuit board 15 has fixed contacts 16 and 17 on its surface and there is further provided a switch element 18 which, similarly to component 6 of the earlier-described embodiment, has the shape of a flat roof. In the center zone of the switch element 18 two longitudinally extending, aligned contact tongues 19 are arranged, with their free end facing one another. When the switch element 18 is actuated as described earlier, the contact tongues 19 engage the respective fixed contacts 16 and 17 to thus establish electric contact therewith.

According to the embodiment of FIG. 4, a rectangular switch element 24 is arranged on a printed circuit

board 21 having fixed contacts 22 and 23 and being provided with openings 20. The switch element 24 is supported on insulating (i.e. conductor-free) zones of the board 21 by means of downwardly bent lateral strip-like legs 25 which form an integral part of the switch element 24. Support tabs 26 extend perpendicularly downwardly from the longitudinal ends of the elevated, flat zone of the switch element 24. Each tab 26 extends into an opening 20 of the board 21 for positioning the switch element 24. Each tab 26 is provided with a shoulder 27 which can be brought into an electrically conducting contact with the fixed contact 22 (or, if required, with fixed contacts 22 provided adjacent both shoulders 27) when the push button (not shown) is actuated. Thus, the shoulders 27 have the function of the hump-like deformations 9 as described earlier. A contact tongue 28, provided in the center zone between the tabs 26, will snap into a lower operating position — for reasons described in connection with the first embodiment (FIGS. 1 and 2) — in which it engages the fixed contact 23. In this operating position the switch element 24 electrically connects the fixed contact 22 with the fixed contact 23.

FIGS. 5 through 7 show an embodiment in which a plurality of switch elements, each associated with a separate push button, are combined into a one-piece structure. On a printed circuit board 29 having fixed contacts 30 and 31, an insulating layer 32 is disposed which is provided with openings 33 in registry with the fixed contacts 30 and 31. A common plate 34 of spring material is arranged on the insulating layer 32 and is provided, for example, by a stamping operation, with a plurality of rectangular switch elements 35 which may be caused to resiliently move with respect to the plate 34. The switch elements 35 extend through openings 33 in the insulating layer 32. The individual switch elements 35 have the shape of a roof (FIG. 7) which has a flat center zone, and are bendably connected with the plate 34 at one edge of the center zone. At the opposite edge the switch elements 35 are provided with humps 36 oriented towards the board 29. A contact tongue 37 forms part of the center zone of each switch element 35. The supporting humps 36 are disposed above the fixed contacts 30 and the contact tongues 37 are disposed above the fixed contacts 31. Each switch element 35 further has integral, lateral strip-like legs which extend at an angle to the flat center zone and which are supported on conductor-free portions of the board 29.

An accumulator spring 38, constituted, for example, by a rubber-elastic tube, is arranged on the plate 34 in such a manner that it extends over a plurality of switch elements 35 (forming one row) perpendicularly to the length dimension of the contact tongues 37 associated therewith. The accumulator spring 38 stores the force exerted on the respective switch element 35 until the latter moves by snap action as described in detail earlier. The accumulator spring 38 is positioned by a switch housing 39 (which is permanently attached to the overall assembly) in such a manner that the accumulator spring 38 is disposed approximately over the center of the switch elements 35 belonging to the same row. Centrally above each switch element 35 there are positioned push buttons 40 which are provided with detent tongues and are guided in the switch housing 39 by a transverse slot guide.

Upon actuation of one of the push buttons 40 by the application of an external (e.g. manual) force, the ac-

Explore Litigation Insights

Docket Alarm provides insights to develop a more informed litigation strategy and the peace of mind of knowing you're on top of things.

Real-Time Litigation Alerts



Keep your litigation team up-to-date with **real-time alerts** and advanced team management tools built for the enterprise, all while greatly reducing PACER spend.

Our comprehensive service means we can handle Federal, State, and Administrative courts across the country.

Advanced Docket Research



With over 230 million records, Docket Alarm's cloud-native docket research platform finds what other services can't. Coverage includes Federal, State, plus PTAB, TTAB, ITC and NLRB decisions, all in one place.

Identify arguments that have been successful in the past with full text, pinpoint searching. Link to case law cited within any court document via Fastcase.

Analytics At Your Fingertips



Learn what happened the last time a particular judge, opposing counsel or company faced cases similar to yours.

Advanced out-of-the-box PTAB and TTAB analytics are always at your fingertips.

API

Docket Alarm offers a powerful API (application programming interface) to developers that want to integrate case filings into their apps.

LAW FIRMS

Build custom dashboards for your attorneys and clients with live data direct from the court.

Automate many repetitive legal tasks like conflict checks, document management, and marketing.

FINANCIAL INSTITUTIONS

Litigation and bankruptcy checks for companies and debtors.

E-DISCOVERY AND LEGAL VENDORS

Sync your system to PACER to automate legal marketing.