

[54] CAPACITIVE TOUCH PANEL SYSTEM WITH RANDOMLY MODULATED POSITION MEASUREMENT SIGNAL

[75] Inventors: R. David Meadows, Beaverton; Roger J. McCoy, Portland, both of Oreg.

[73] Assignee: Tektronix, Inc., Beaverton, Oreg.

[21] Appl. No.: 383,113

[22] Filed: Jul. 20, 1989

Related U.S. Application Data

[63] Continuation-in-part of Ser. No. 205,896, Jun. 13, 1988, Pat. No. 4,853,498.

[51] Int. Cl.⁵ G08C 21/00

[52] U.S. Cl. 178/19; 340/706

[58] Field of Search 178/19; 340/706

References Cited

U.S. PATENT DOCUMENTS

4,476,463	10/1984	Ng et al.	340/712
4,680,430	7/1987	Yoshikawa et al.	178/19
4,698,460	10/1987	Krein et al.	178/19
4,698,461	10/1987	Meadows et al.	178/19
4,707,845	11/1987	Krein et al.	178/19

Primary Examiner—Stafford D. Schreyer
Attorney, Agent, or Firm—John D. Winkelman; Mark M. Meininger

[57] ABSTRACT

A capacitive touch panel system (10) having a faceplate (14) with an electrically conductive layer (20) of a consistent resistivity employs a position measurement apparatus (12) to generate an address signal indicative of a position (46) on the faceplate in contact with a stylus (48). The position measurement apparatus includes a position measurement signal source (56) that generates a square-wave measurement signal of a frequency that varies in a substantially random manner. The position measurement signal is applied to a first pair of opposed electrodes (36) and (40) and a second pair of opposed electrodes (38) and (42) positioned along respective side margins (26, 30, 28, and 32) of the faceplate. The resistivity of the conductive layer establishes effective resistances of R_x and R_y between the respective first and second pairs of electrodes. Position measurement sub-circuits (54a-54d) are locked-in with the random measurement signal frequencies to measure currents drawn through the electrodes whenever the stylus contacts the conductive layer, thereby to form an address signal indicative of the location at which the stylus contacts the faceplate. The random measurement signal frequencies reduce the susceptibility of the position measurement apparatus to electromagnetic noise and distributes over a relatively broad bandwidth the electromagnetic noise generated by the position measurement apparatus.

22 Claims, 2 Drawing Sheets

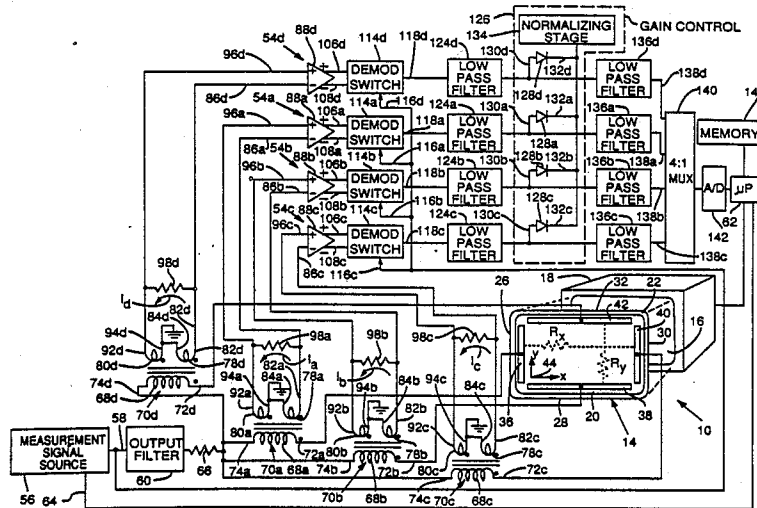

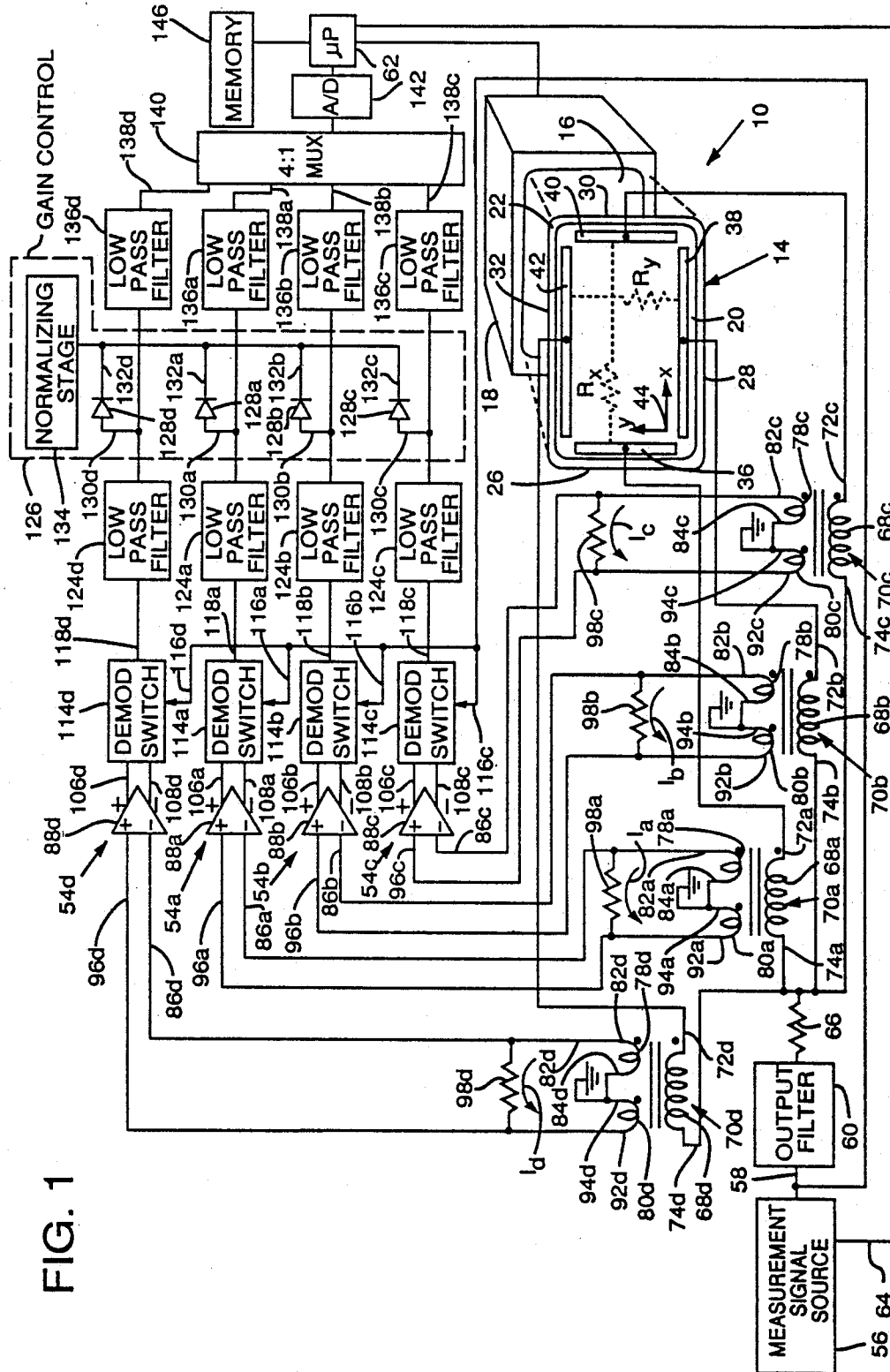

FIG. 1

CAPACITIVE TOUCH PANEL SYSTEM WITH RANDOMLY MODULATED POSITION MEASUREMENT SIGNAL

This is a continuation-in-part of application Ser. No. 07/205,896, filed June 13, 1988, U.S. Pat. No. 4,853,498.

TECHNICAL FIELD

The present invention relates to touch panel systems of the type having electrically conductive faceplates and, in particular, to such a touch panel system in which a position measurement apparatus generates an address signal that is indicative of a location at which a stylus contacts the faceplate.

BACKGROUND OF THE INVENTION

A touch panel system is a data input device that allows an operator to interact with information rendered on a display screen. For example, the operator can select one of multiple computer command options rendered at different locations on the display screen by touching the screen at one of the locations. A touch panel system employs a position measurement apparatus that generates an address signal indicative of the touched location. The address signal is delivered to a computer that determines from the address signal which one of the command options is selected. The object with which the operator touches the display screen is called a stylus and may include, for example, the operator's finger, a pen, or a pencil.

A touch panel system of the capacitive-type typically includes a faceplate that has on its outer major surface an optically transparent, electrically conductive coating of a preselected resistivity. The faceplate is positioned in front of the display screen of a display device so that an operator can touch the conductive coating at locations aligned with information rendered on the display screen.

The operator touches the conductive coating with a stylus having a nonzero, finite capacitance with reference to electrical ground. The stylus causes a change in the characteristics of an amplitude modulated position measurement signal applied to the conductive coating. The touch panel system distinguishes the location the stylus contacts from the other locations on the faceplate in accordance with the change in the characteristics of the position measurement signal.

The conductive coating on the faceplate causes a capacitive touch panel system to suffer from at least two disadvantages. First, the conductive coating is receptive to electromagnetic noise generated by the display system (e.g. cathode-ray tube flyback pulses) or present within the environment (e.g. 60 Hz background noise). Such noise susceptibility can render difficult the determination of a touch location. Second, the conductive coating causes the touch panel system to generate electromagnetic interference at the frequency of the position measurement signal. As a result, a capacitive touch panel system typically generates substantial amounts of electromagnetic noise.

SUMMARY OF THE INVENTION

An object of the present invention is, therefore, to provide a position measurement apparatus for a capacitive touch panel system.

Another object of this invention is to provide such an apparatus having a reduced susceptibility to electromagnetic noise.

A further object of this invention is to provide such a system that generates reduced amounts of electromagnetic noise at any single specific measurement signal frequency.

The present invention is a touch panel system with a position measurement apparatus that generates an address signal indicative of a position on the touch panel in contact with a capacitive stylus. The stylus has a nonzero, finite capacitance with reference to electrical ground.

In a preferred embodiment, the touch panel system includes a rectangular faceplate with an electrically conductive layer. The conductive layer has a consistent resistivity, covers the entire outer major surface of the faceplate, and carries four bar electrodes. A different one of the bar electrodes extends along almost the entire length and near each of the side margins of the outer major surface of the faceplate. The bar electrodes form two pairs of generally parallel opposed electrical contacts. Each bar electrode is electrically connected to the conductive layer and the position measurement apparatus.

The position measurement apparatus includes a measurement signal source that generates an amplitude modulated measurement signal of a frequency that varies in a substantially random manner. The measurement signal is applied simultaneously to each of the bar electrodes. The apparatus identifies a position on the faceplate in contact with the stylus by measuring the measurement signal current that the stylus draws through each electrode. The current drawn through each electrode is inversely proportional to the separation between the electrode and the position at which the stylus touches the faceplate. The current measurements obtained with respect to the four electrodes are analyzed by a microprocessor to identify the position.

The position is identified separately with respect to each one of the bar electrodes. The following description relates to the position identification with respect to an exemplary one of the bar electrodes. Such description would apply similarly to each of the three remaining electrodes.

The signal source transmits the measurement signal to the bar electrode through the primary coil of a transformer. The transformer develops across the output terminals of a secondary coil a potential difference proportional to the current that the stylus draws through the bar electrode. A differential amplifier having first and second input terminals is electrically connected to the output terminals of the secondary coil of the transformer. The differential amplifier receives the potential difference and generates positive and negative differential output signals proportional to the current. The transformer cooperates, therefore, with the differential amplifier to function as a current meter that measures the current drawn through the electrode.

A signal demodulator of the lock-in type employs the same random frequency measurement signal as a reference for demodulating the positive and negative differential output signals. A low-pass filter connected to the signal demodulator provides from the demodulated signal a substantially steady-state address signal that corresponds to an average of the magnitude of the current drawn through the bar electrode.

The position measurement apparatus of the present invention has reduced susceptibility to electromagnetic noise because of the lock-in characteristics of the signal demodulator and the low-pass filter. In addition, the position measurement apparatus of this invention generates electromagnetic noise that is spread over the bandwidth of the random frequencies of the position measurement signal. As a result, the position measurement apparatus generates reduced amounts of electromagnetic noise at any single specific measurement signal frequency.

Additional objects and advantages of the present invention will be apparent from the detailed description of a preferred embodiment thereof, which proceeds with reference to the accompanying drawings.

BRIEF DESCRIPTION OF THE DRAWINGS

FIG. 1 is a schematic block diagram of a position measurement apparatus of the present invention implemented in a touch panel system.

FIG. 2 is an enlarged frontal schematic diagram of the faceplate of the touch panel system of FIG. 1.

FIG. 3 is a circuit block diagram of a measurement signal source employed in the position measurement apparatus of FIG. 1.

DETAILED DESCRIPTION OF PREFERRED EMBODIMENT

FIG. 1 schematically shows a touch panel system 10 and an associated position measurement apparatus 12 of the present invention. Touch panel system 10 includes an optically transparent faceplate 14 positioned face-to-face with the display screen 16 of a display device 18 that incorporates, for example, a cathode-ray tube. It will be appreciated that the display device 18 could alternatively include a liquid crystal display or a signboard that displays fixed information such as a numeric key pad.

Faceplate 14 includes an optically transparent, electrically conductive layer 20 that covers substantially all of an outer major surface 22 of faceplate 14. Layer 20 is formed from indium tin oxide (ITO) and has a consistent resistivity. Faceplate 14 is typically of a rectangular shape and includes on major surface 22 a first pair of opposed side margins 26 and 30 and a second pair of opposed side margins 28 and 32.

Electrodes 36, 38, 40 and 42 in the form of bars or strips are positioned on and extend along major portions of the lengths of side margins 26, 28, 30, and 32, respectively. Electrodes 36 and 40 and electrodes 38 and 42 form two pairs of opposed electrical contacts that are electrically connected along their lengths to conductive layer 20. Electrodes 36 and 40 define across faceplate 14 an X-axis having its origin 44 located near the bottom side of electrode 36, and electrodes 38 and 42 define across faceplate 14 a Y-axis having its origin 44 located near the left side of electrode 38.

The resistivity of layer 20 establishes effective total resistances R_x and R_y in the respective X- and Y-axis directions across faceplate 14. Position measurement apparatus 12 identifies a position or location 46 (FIG. 2) on faceplate 14 in contact with a capacitive stylus 48 (FIG. 2) such as, for example, a person's finger. (The location 46 is hereinafter referred to as "touch location 46.") Stylus 48 may be modeled as a capacitor 50 and a resistor 52 electrically connected in parallel to ground. Capacitor 50 can have a capacitance of between 5 and several hundred picofarads. Resistor 52 can have effec-

tively any resistance. Position measurement apparatus 12 identifies touch location 46 by measuring the separation between location 46 and each one of electrodes 36, 38, 40, and 42.

Position measurement apparatus 12 comprises four similar position measurement subcircuits 54a, 54b, 54c, and 54d that are connected to the respective electrodes 36, 38, 40, and 42 to generate an address signal indicative of the separation between touch location 46 and each of the electrodes. Subcircuits 54a-54d preferably operate simultaneously or "in parallel" to generate the address signal. Corresponding components of position measurement subcircuits 54a-54d have identical reference numerals with letter suffices "a"- "d", respectively. The following description is directed by way of example only to position measurement subcircuit 54a and is similarly applicable to position measurement subcircuits 54b-54d.

A position measurement signal source 56 generates a bipolar continuous square-wave measurement signal and is delivered to an input 58 of a source output filter 60. The measurement signal alternates between a positive voltage, +V, and a negative voltage level, -V, at a frequency that varies in a substantially random manner. In the preferred embodiment, a microprocessor 62 functions as a pseudo-random number generator that generates a pseudo-random number signal that is delivered to an input 64 of measurement signal source 56. In response to the pseudo-random number signal, measurement signal source 56 generates the measurement signal with a frequency of between 150 and 250 kHz in accordance with the value of the pseudo-random number. Microprocessor 62 generates the pseudo-random numbers at a frequency of about 50 kHz.

Output filter 60 is preferably of the low-pass type and cooperates with an output resistor 66 to establish an output impedance of 2 kilohms. This output impedance functions to improve the uniformity of the signal-to-noise ratios of the signals on electrodes 36-42, as will be described below in greater detail. Output filter 60 delivers the square-wave measurement signal to electrode 36 via the primary coil 68a of a transformer 70a. Primary coil 68a is arranged so that its positive terminal 72a and negative terminal 74a are electrically connected to electrode 36 and the output resistor 66 of filter 60 respectively.

With reference to FIGS. 1 and 2, stylus 48 in contact with touch location 46 may be modeled as dividing the resistance R_x into a first resistance $k_x R_x$ and a second resistance $(1-k_x)R_x$, the term k_x representing the normalized distance 76a between touch location 46 and electrode 36. The first resistance represents the resistance of layer 20 between touch location 46 and electrode 36, and the second resistance represents the resistance of layer 20 between touch location 46 and electrode 40. Stylus 48 in contact with layer 20 draws currents proportional to the measurement signal to electrical ground. Position measurement subcircuits 54a and 54c measure the currents drawn to electrical ground via the respective first and second resistances, thereby to indicate the position of touch location 46 along the X-axis.

With reference to position measurement subcircuit 54a, transformer 70a includes two secondary coils 78a and 80a that are inductively coupled to primary coil 68a. Secondary coil 78a has a positive terminal 82a and a negative terminal 84a that are electrically connected to an inverting input 86a of a differential amplifier 88a

Explore Litigation Insights

Docket Alarm provides insights to develop a more informed litigation strategy and the peace of mind of knowing you're on top of things.

Real-Time Litigation Alerts



Keep your litigation team up-to-date with **real-time alerts** and advanced team management tools built for the enterprise, all while greatly reducing PACER spend.

Our comprehensive service means we can handle Federal, State, and Administrative courts across the country.

Advanced Docket Research



With over 230 million records, Docket Alarm's cloud-native docket research platform finds what other services can't. Coverage includes Federal, State, plus PTAB, TTAB, ITC and NLRB decisions, all in one place.

Identify arguments that have been successful in the past with full text, pinpoint searching. Link to case law cited within any court document via Fastcase.

Analytics At Your Fingertips



Learn what happened the last time a particular judge, opposing counsel or company faced cases similar to yours.

Advanced out-of-the-box PTAB and TTAB analytics are always at your fingertips.

API

Docket Alarm offers a powerful API (application programming interface) to developers that want to integrate case filings into their apps.

LAW FIRMS

Build custom dashboards for your attorneys and clients with live data direct from the court.

Automate many repetitive legal tasks like conflict checks, document management, and marketing.

FINANCIAL INSTITUTIONS

Litigation and bankruptcy checks for companies and debtors.

E-DISCOVERY AND LEGAL VENDORS

Sync your system to PACER to automate legal marketing.