

<b>INFORMATION DISCLOSURE STATEMENT BY APPLICANT</b> ( Not for submission under 37 CFR 1.99)	Application Number		90013106 - GAU: 3992
	Filing Date		
	First Named Inventor	Byron Hourmand	
	Art Unit		
	Examiner Name		
	Attorney Docket Number	5796183RX	

6	HLADY, A.M., "A touch sensitive X-Y position encoder for computer input," Proceedings of the Fall Joint Computer Conference, November 18-20, 1969, pp. 545-551.	<input type="checkbox"/>
7	SASAKI, L., et al., "A Touch-Sensitive Input Device," International Computer Music Conference Proceedings, November 1981, pp. 293-296.	<input type="checkbox"/>
8	CALLAHAN, J., et al., "An Empirical Comparison of Pie vs. Linear Menus," Human Factors in Computing Systems: Chicago '88 Conference Proceedings: May 15-19, 1988, Washington DC: Special Issue of the SIGCHI Bulletin, New York: Association for Computing Machinery, pp. 95-100.	<input type="checkbox"/>
/HT/ 9	CASIO, AT-550 Advertisement, published in Popular Science by On The Run, February 1984, p.-129.	<input type="checkbox"/>
10	CASIO, "Module No. 320," AT-550 Owner's Manual, at least as early as December 1984, 14 pages.	<input type="checkbox"/>
11	SMITH, S.D., et al., "Bit-slice microprocessors in h.f. digital communications," The Radio and Electronic Engineer, Vol. 51, No. 6, June 1981, pp. 299-301.	<input type="checkbox"/>
12	BOIE, R.A., "Capacitive Impedance Readout Tactile Image Sensor," Proceedings of the IEEE International Conference on Robotics and Automation, Vol. 1, March 1984, pp. 370-372.	<input type="checkbox"/>
13	THOMPSON, C., "Clive Thompson on The Breakthrough Myth," Wired Magazine, <a href="http://www.wired.com/magazine/2011/07/st_thompson_breakthrough">http://www.wired.com/magazine/2011/07/st_thompson_breakthrough</a> , August 2011, 3 pages.	<input type="checkbox"/>
14	"Innovation in Information Technology," National Research Council of the National Academies, Computer Science and Telecommunications Board, Division on Engineering and Physical Sciences, <a href="http://www.nap.edu/catalog/10795.html">http://www.nap.edu/catalog/10795.html</a> , 2003, 85 pages.	<input type="checkbox"/>
15	BUXTON, W., et al., "Issues and Techniques in Touch-Sensitive Tablet Input," Proceedings of SIGGRAPH '85, Vol. 19, No. 3, July 22-26, 1985, pp. 215-223.	<input type="checkbox"/>
16	BUXTON, W., et al., "Large Displays in Automotive Design," IEEE Computer Graphics and Applications, July/August 2000, pp. 68-75.	<input type="checkbox"/>

EFS Web 2.1.17

<b>INFORMATION DISCLOSURE STATEMENT BY APPLICANT</b> ( Not for submission under 37 CFR 1.99)	Application Number		90013106 - GAU: 3992
	Filing Date		
	First Named Inventor	Byron Hourmand	
	Art Unit		
	Examiner Name		
	Attorney Docket Number	5796183RX	

17	BUXTON, W., "Lexical and Pragmatic Considerations of Input Structures," ACM SIGGRAPH Computer Graphics, Vol. 17, No. 1, January 1983, pp. 31-37.	<input type="checkbox"/>
18	BETTS, P., et al., "Light Beam Matrix Input Terminal," IBM Technical Disclosure Bulletin, October 1966, pp. 493-494.	<input type="checkbox"/>
19	BUXTON, B., "Multi-Touch Systems that I Have Known and Loved," downloaded from <a href="http://www.billbuxton.com/multitouchOverview.html">http://www.billbuxton.com/multitouchOverview.html</a> , January 12, 2007, 22 pages.	<input type="checkbox"/>
20	HEROT, C.F., et al., "One-Point Touch Input of Vector Information for Computer Displays," Proceedings of the 5th Annual Conference on Computer Graphics and Interactive Techniques, August 23-25, 1978, pp. 210-216.	<input type="checkbox"/>
21	WOLFELD, J.A., "Real Time Control of a Robot Tactile Sensor," University of Pennsylvania, Department of Computer & Information Science, Technical Reports (CIS), Master Thesis, <a href="http://repository.upenn.edu/cis-reports/678">http://repository.upenn.edu/cis-reports/678</a> , August 1981, 68 pages.	<input type="checkbox"/>
22	LEWIS, J.R., "Reaping the Benefits of Modern Usability Evaluation: The Simon Story," Advances in Applied Ergonomics: Proceedings of the 1st International Conference on Applied Ergonomics, ICAE May 21-24, 1996, pp. 752-755.	<input type="checkbox"/>
23	NAKATANI, L.H., et al., "Soft Machines: A Philosophy of User-Computer Interface Design," Proceedings of the SIGCHI Conference on Human Factors in Computing Systems, December 1983, Chicago, pp. 19-23.	<input type="checkbox"/>
24	RUBINE, D.H., "The Automatic Recognition of Gestures," Carnegie Mellon University, Master Thesis, CMU-CS-91-202, December, 1991, 285 pages.	<input type="checkbox"/>
25	KURTENBACH, S.P., "The Design and Evaluation of Marking Menus," University of Toronto, Graduate Department of Computer Science, Master Thesis, May 1993, 201 pages.	<input type="checkbox"/>
26	HOPKINS, D., "The Design and Implementation of Pie Menus," originally published in Dr. Dobb's Journal, December 1991, lead cover story, user interface issue, reproduced at <a href="http://www.DonHopkins.com">www.DonHopkins.com</a> , 8 pages.	<input type="checkbox"/>
27	BUXTON, B., "The Long Nose of Innovation," Bloomberg Businessweek, Innovation & Design, January 2, 2008, 3 pages, downloaded from: <a href="http://www.businessweek.com/stories/2008-01-02/the-long-nose-of-innovationbusinessweek-business-news-stock-market-and-financialadvice">http://www.businessweek.com/stories/2008-01-02/the-long-nose-of-innovationbusinessweek-business-news-stock-market-and-financialadvice</a> .	<input type="checkbox"/>

<b>INFORMATION DISCLOSURE STATEMENT BY APPLICANT</b> ( Not for submission under 37 CFR 1.99)	Application Number		90013106 - GAU: 3992
	Filing Date		
	First Named Inventor	Byron Hourmand	
	Art Unit		
	Examiner Name		
	Attorney Docket Number		5796183RX

28	BUXTON, B., "The Mad Dash Toward Touch Technology," Bloomberg Businessweek, Innovation & Design, October 21, 2009, 3 pages, downloaded from: <a href="http://www.businessweek.com/innovate/content/oct2009/id20091021_629786.htm">http://www.businessweek.com/innovate/content/oct2009/id20091021_629786.htm</a> .	<input type="checkbox"/>
29	"The Sensor Frame Graphic Manipulator," NASA Phase II Final Report, NASA-CR-194243, May 8, 1992, 28 pages.	<input type="checkbox"/>
30	IZADI, S., et al., "ThinSight: A Thin Form-Factor Interactive Surface Technology," Communications of the ACM, Research Highlights, Vol. 52, No. 12, December 2009, pp. 90-98.	<input type="checkbox"/>
31	KRUEGER, M.W., et al., "VIDEOPPLACE - An Artificial Reality," Proceedings of the SIGCHI Conference on Human Factors in Computing Systems, April 1985, pp. 35-40.	<input type="checkbox"/>
32	BROWN, E., et al., "Windows on Tablets as a Means of Achieving Virtual Input Devices," Proceedings of the IFIP TC13 Third International Conference on Human-Computer Interaction, August 27-31, 1990, in D. Diaper, et al. (Eds), Human-Computer Interaction - INTERACT '90, Amsterdam: Elsevier Science Publishers B.V. (North Holland), 11 pages.	<input type="checkbox"/>
33	"A Multi-Touch Three Dimensional Touch-Sensitive Tablet," <a href="http://www.youtube.com/watch?v=Arrus9CxUiA">http://www.youtube.com/watch?v=Arrus9CxUiA</a> , November 18, 2009, 1 page.	<input type="checkbox"/>
34	"Casio AT-550 Touch Screen Calculator Watch (1984)," <a href="http://www.youtube.com/watch?v=UhVAsqhfhqU">http://www.youtube.com/watch?v=UhVAsqhfhqU</a> , May 24, 2012, 1 page.	<input type="checkbox"/>

If you wish to add additional non-patent literature document citation information please click the Add button **Add**

**EXAMINER SIGNATURE**

Examiner Signature	/Henry Tran/ (02/20/2014)	Date Considered	
--------------------	---------------------------	-----------------	--

\*EXAMINER: Initial if reference considered, whether or not citation is in conformance with MPEP 609. Draw line through a citation if not in conformance and not considered. Include copy of this form with next communication to applicant.

<sup>1</sup> See Kind Codes of USPTO Patent Documents at [www.USPTO.GOV](http://www.USPTO.GOV) or MPEP 901.04. <sup>2</sup> Enter office that issued the document, by the two-letter code (WIPO Standard ST.3). <sup>3</sup> For Japanese patent documents, the indication of the year of the reign of the Emperor must precede the serial number of the patent document. <sup>4</sup> Kind of document by the appropriate symbols as indicated on the document under WIPO Standard ST.16 if possible. <sup>5</sup> Applicant is to place a check mark here if English language translation is attached.

<b>INFORMATION DISCLOSURE STATEMENT BY APPLICANT</b> ( Not for submission under 37 CFR 1.99)	Application Number		90013106 - GAU: 3992
	Filing Date		
	First Named Inventor	Byron Hourmand	
	Art Unit		
	Examiner Name		
	Attorney Docket Number	5796183RX	

**CERTIFICATION STATEMENT**

Please see 37 CFR 1.97 and 1.98 to make the appropriate selection(s):

That each item of information contained in the information disclosure statement was first cited in any communication from a foreign patent office in a counterpart foreign application not more than three months prior to the filing of the information disclosure statement. See 37 CFR 1.97(e)(1).

**OR**

That no item of information contained in the information disclosure statement was cited in a communication from a foreign patent office in a counterpart foreign application, and, to the knowledge of the person signing the certification after making reasonable inquiry, no item of information contained in the information disclosure statement was known to any individual designated in 37 CFR 1.56(c) more than three months prior to the filing of the information disclosure statement. See 37 CFR 1.97(e)(2).

- See attached certification statement.
- The fee set forth in 37 CFR 1.17 (p) has been submitted herewith.
- A certification statement is not submitted herewith.

**SIGNATURE**

A signature of the applicant or representative is required in accordance with CFR 1.33, 10.18. Please see CFR 1.4(d) for the form of the signature.

Signature	/Brian A. Carlson/	Date (YYYY-MM-DD)	2013-12-24
Name/Print	Brian A. Carlson	Registration Number	37,793

This collection of information is required by 37 CFR 1.97 and 1.98. The information is required to obtain or retain a benefit by the public which is to file (and by the USPTO to process) an application. Confidentiality is governed by 35 U.S.C. 122 and 37 CFR 1.14. This collection is estimated to take 1 hour to complete, including gathering, preparing and submitting the completed application form to the USPTO. Time will vary depending upon the individual case. Any comments on the amount of time you require to complete this form and/or suggestions for reducing this burden, should be sent to the Chief Information Officer, U.S. Patent and Trademark Office, U.S. Department of Commerce, P.O. Box 1450, Alexandria, VA 22313-1450. **DO NOT SEND FEES OR COMPLETED FORMS TO THIS ADDRESS. SEND TO: Commissioner for Patents, P.O. Box 1450, Alexandria, VA 22313-1450.**

**Privacy Act Statement**

The Privacy Act of 1974 (P.L. 93-579) requires that you be given certain information in connection with your submission of the attached form related to a patent application or patent. Accordingly, pursuant to the requirements of the Act, please be advised that: (1) the general authority for the collection of this information is 35 U.S.C. 2(b)(2); (2) furnishing of the information solicited is voluntary; and (3) the principal purpose for which the information is used by the U.S. Patent and Trademark Office is to process and/or examine your submission related to a patent application or patent. If you do not furnish the requested information, the U.S. Patent and Trademark Office may not be able to process and/or examine your submission, which may result in termination of proceedings or abandonment of the application or expiration of the patent.

The information provided by you in this form will be subject to the following routine uses:

1. The information on this form will be treated confidentially to the extent allowed under the Freedom of Information Act (5 U.S.C. 552) and the Privacy Act (5 U.S.C. 552a). Records from this system of records may be disclosed to the Department of Justice to determine whether the Freedom of Information Act requires disclosure of these records.
2. A record from this system of records may be disclosed, as a routine use, in the course of presenting evidence to a court, magistrate, or administrative tribunal, including disclosures to opposing counsel in the course of settlement negotiations.
3. A record in this system of records may be disclosed, as a routine use, to a Member of Congress submitting a request involving an individual, to whom the record pertains, when the individual has requested assistance from the Member with respect to the subject matter of the record.
4. A record in this system of records may be disclosed, as a routine use, to a contractor of the Agency having need for the information in order to perform a contract. Recipients of information shall be required to comply with the requirements of the Privacy Act of 1974, as amended, pursuant to 5 U.S.C. 552a(m).
5. A record related to an International Application filed under the Patent Cooperation Treaty in this system of records may be disclosed, as a routine use, to the International Bureau of the World Intellectual Property Organization, pursuant to the Patent Cooperation Treaty.
6. A record in this system of records may be disclosed, as a routine use, to another federal agency for purposes of National Security review (35 U.S.C. 181) and for review pursuant to the Atomic Energy Act (42 U.S.C. 218(c)).
7. A record from this system of records may be disclosed, as a routine use, to the Administrator, General Services, or his/her designee, during an inspection of records conducted by GSA as part of that agency's responsibility to recommend improvements in records management practices and programs, under authority of 44 U.S.C. 2904 and 2906. Such disclosure shall be made in accordance with the GSA regulations governing inspection of records for this purpose, and any other relevant (i.e., GSA or Commerce) directive. Such disclosure shall not be used to make determinations about individuals.
8. A record from this system of records may be disclosed, as a routine use, to the public after either publication of the application pursuant to 35 U.S.C. 122(b) or issuance of a patent pursuant to 35 U.S.C. 151. Further, a record may be disclosed, subject to the limitations of 37 CFR 1.14, as a routine use, to the public if the record was filed in an application which became abandoned or in which the proceedings were terminated and which application is referenced by either a published application, an application open to public inspections or an issued patent.
9. A record from this system of records may be disclosed, as a routine use, to a Federal, State, or local law enforcement agency, if the USPTO becomes aware of a violation or potential violation of law or regulation.

# Litigation Search Report CRU 3999

Reexam Control No. 90/013,106

<b>TO: Henry Tran</b> <b>Location: CRU</b> <b>Art Unit: 3992</b> <b>Date: 01/27/2014</b>	<b>From: Shanette Brown</b> <b>Location: CRU 3999</b> <b>MDE 05D10</b> <b>Phone: (571) 272-6632</b> <b>Shanett.Brown@uspto.gov</b>
---	--

## Search Notes

RE: 90/013,106–Litigation was found for US Patent Number: 5,796,183

Patent	Class	Subclass	Description	Court	Docket Number	Filed	Date Retrieved
5,796,183	307	116	QRG, Ltd, A/K/A Quantum Research Group, Ltd v. Nartron Corporatio	US-DIS-PAMD	1:06cv1777 CLOSED	9/12/2006	5/7/2008
5,796,183	307	116	Nartron Corporation et al v. Hourmand	US-DIS-MIWD	1:10cv691 CLOSED	7/20/2010	10/29/2010
5,796,183	307	116	Nartron Corp v. Gen Elec, et al	US-DIS-MIED	2:03cv75169 CLOSED	12/24/2003	1/5/2012
5,796,183	307	116	QRG, Ltd v. Nartron Corporation	US-DIS-PAWD	2:06cv500 CLOSED	4/13/2006	5/7/2008

### Sources:

- 1) I performed a KeyCite Search in Westlaw, which retrieves all history on the patent including any litigation.
- 2) I performed a search on the patent in Lexis CourtLink for any open dockets or closed cases.
- 3) I performed a search in Lexis in the Federal Courts and Administrative Materials databases for any cases found.
- 4) I performed a search in Lexis in the IP Journal and Periodicals database for any articles on the patent.
- 5) I performed a search in Lexis in the news databases for any articles about the patent or any articles about litigation on this patent.

**Westlaw Delivery Summary Report for BROWN,SHANETTE L**

Date/Time of Request:	Sunday, January 26, 2014 14:47 Central
Client Identifier:	SB
Database:	KEYCITE-HIST
Citation Text:	US PAT 5796183
Service:	KeyCite
Lines:	369
Documents:	1
Images:	0

The material accompanying this summary is subject to copyright. Usage is governed by contract with Thomson Reuters, West and their affiliates.



Date of Printing: Jan 26, 2014

**KEYCITE**

© US PAT 5796183 CAPACITIVE RESPONSIVE ELECTRONIC SWITCHING CIRCUIT, Assignee:  
Nartron Corporation (Aug 18, 1998)

**History****Direct History**

=> 1 CAPACITIVE RESPONSIVE ELECTRONIC SWITCHING CIRCUIT, US PAT 5796183,  
1998 WL 1463338 (U.S. PTO Utility Aug 18, 1998)

**Patent Family**

2 CAPACITIVE REACTION ELECTRONIC SWITCH FOR ZERO FORCE APPLICATION  
CONTAINS OSCILLATOR SUPPLYING FREQUENCY OF 50 KHZ OR HIGHER, AND  
INPUT TOUCH TERMINAL, Derwent World Patents Legal 1997-394976+

**Assignments**

3 Action: ASSIGNMENT OF ASSIGNORS INTEREST (SEE DOCUMENT FOR DETAILS).  
Number of Pages: 002, (DATE RECORDED: Aug 17, 2012)  
4 Action: ASSIGNMENT OF ASSIGNORS INTEREST (SEE DOCUMENT FOR DETAILS).  
Number of Pages: 002, (DATE RECORDED: Aug 17, 2012)  
5 Action: ASSIGNMENT OF ASSIGNORS INTEREST (SEE DOCUMENT FOR DETAILS).  
Number of Pages: 011, (DATE RECORDED: Dec 22, 2009)  
6 ASSIGNEE(S): NARTRON CORPORATION, (DATE RECORDED: Feb 04, 1997)  
7 Assignee(s): NARTRON CORPORATION, (DATE RECORDED: Jan 31, 1996)

**Patent Status Files**

.. Re-Examination Certificate, (OG DATE: May 07, 2013)  
.. Request for Re-Examination, (OG DATE: Oct 02, 2012)  
.. Certificate of Correction, (OG DATE: Nov 01, 2011)  
.. Certificate of Correction, (OG DATE: May 11, 1999)

**Docket Summaries**

12 NARTRON CORPORATION ET AL v. HOURMAND, (W.D.MICH. Jul 20, 2010) (NO.  
1:10CV00691), (28 USC 1338 PATENT INFRINGEMENT)  
13 "QRG, LTD. v. NARTRON CORPORATION", (M.D.PA. Sep 12, 2006) (NO. 1:06CV01777),  
(28 USC 2201 DECLARATORY JUDGEMENT)

© 2014 Thomson Reuters. All rights reserved.



14 "NARTRON CORP v. GEN ELEC, ET AL", (E.D.MICH. Dec 24, 2003) (NO. 2:03CV75169)

#### Litigation Alert

- 15 Derwent LitAlert P2010-30-63 (Jul 20, 2010) Action Taken: complaint for PATENT INFRINGEMENT
- 16 Derwent LitAlert P2007-35-68 (Sep 12, 2006) Action Taken: A complaint was filed
- 17 Derwent LitAlert P2007-02-10 (Apr 13, 2006) Action Taken: Order of court - Ordered that motion to dismiss by defendant is denied. Further ordered that the case is to be transferred to the US District Court for the Middle Dist of Pennsylvania

#### Prior Art (Coverage Begins 1976)

- 18 CAPACITIVE PRESS CONTROL ACTUATION SYSTEM, US PAT 5235217 Assignee: ISB Ltd., (U.S. PTO Utility 1993)
- 19 CAPACITIVE SENSOR CONTROL SYSTEM, US PAT 4323829 Assignee: Fish, Barry M., (U.S. PTO Utility 1982)
- 20 CAPACITY RESPONSIVE CONTROL CIRCUIT, US PAT 4831279 Assignee: Nartron Corporation, (U.S. PTO Utility 1989)
- 21 CAPACITY RESPONSIVE KEYBOARD, US PAT 5087825 Assignee: Nartron Corporation, (U.S. PTO Utility 1992)
- 22 CHARGE SENSITIVE SWITCH, US PAT 4159473 Assignee: Johnson-Lazare Canada Limited, (U.S. PTO Utility 1979)
- 23 CONTROL-SAFE CAPACITIVE SWITCH, US PAT 5233231 Assignee: Pepperl + Fuchs, Inc., (U.S. PTO Utility 1993)
- 24 DC TOUCH CONTROL SWITCH CIRCUIT, US PAT 4758735 Assignee: Nartron Corporation, (U.S. PTO Utility 1988)
- 25 DISCRIMINATING CONTACT SENSOR, US PAT 3911215 Assignee: ELOGRAPHICS, INC., (U.S. PTO Utility 1975)
- 26 DISPLAY DEVICE HAVING UNPATTERNED TOUCH DETECTION, US PAT 4476463 Assignee: Interaction Systems, Inc., (U.S. PTO Utility 1984)
- 27 ELECTROGRAPHIC SENSOR FOR DETERMINING PLANAR COORDINATES, US PAT 3798370 Assignee: ELOGRAPHICS, INC., (U.S. PTO Utility 1974)
- 28 ELECTRONIC SWITCH ARRANGEMENTS, US PAT 3651391 Assignee: BLACK & DECKER INC., (U.S. PTO Utility 1972)
- 29 ELECTRONIC WATCH WITH TOUCH-SENSITIVE KEYS, US PAT 4257117 Assignee: Ebauches S.A., (U.S. PTO Utility 1981)
- 30 ELECTRONICALLY ACTUATED ELECTRIC SWITCH, US PAT 4213061 (U.S. PTO Utility 1980)
- 31 HAND SANITIZING STATION, US PAT 4942631 Assignee: Barry Robertson; Rosa, Rudy, (U.S. PTO Utility 1990)
- 32 INDUCTION COOK-TOP WITH IMPROVED TOUCH CONTROL, US PAT 4308443 Assignee:

© 2014 Thomson Reuters. All rights reserved.

- Rangaire Corporation, (U.S. PTO Utility 1981)
- C** 33 KEYBOARD SWITCH, US PAT 4503294 Assignee: Nippon Mektron Ltd., (U.S. PTO Utility 1985)
  - C** 34 LAMP RESPONSIVE TO THE HUMAN TOUCH UPON A LIVING PLANT AND CONTROL SYSTEM THEREFOR, US PAT 4152629 (U.S. PTO Utility 1979)
  - C** 35 LUCENT ELECTROGRAPHIC SENSOR FOR DETERMINING PLANAR COORDINATES, US PAT 4071689 Assignee: Elographics, Incorporated, (U.S. PTO Utility 1978)
  - C** 36 MULTI-WAY SWITCH SYSTEM HAVING PLURAL REMOTE TOUCH PADS, US PAT 5066898 Assignee: Delat Systems, Incorporated, (U.S. PTO Utility 1991)
  - C** 37 NONPLANAR TRANSPARENT ELECTROGRAPHIC SENSOR, US PAT 4220815 Assignee: Elographics, Inc., (U.S. PTO Utility 1980)
  - C** 38 PERSONAL-CARE APPARATUS COMPRISING A CAPACITIVE ON/OFF SWITCH, US PAT 5453644 Assignee: U.S. Philips Corporation, (U.S. PTO Utility 1995)
  - C** 39 PROXIMITY ACTUATED POWER CONTROL VARIABLE AS TO SENSE AND MAGNITUDE, US PAT 3984757 (U.S. PTO Utility 1976)
  - C** 40 PROXIMITY CONTROLLED POWER SWITCHING CIRCUIT, US PAT 4246533 (U.S. PTO Utility 1981)
  - C** 41 PROXIMITY PAD WITH CONTROLLED ILLUMINATION, US PAT 4016453 (U.S. PTO Utility 1977)
  - C** 42 PROXIMITY SWITCHING SYSTEM, US PAT 4031408 (U.S. PTO Utility 1977)
  - C** 43 SELF TIMING SWITCH, US PAT 3965465 (U.S. PTO Utility 1976)
  - C** 44 SINGLE-ELECTRODE CAPACITANCE TOUCHPAD SENSOR SYSTEMS, US PAT 4237421 Assignee: General Electric Company, (U.S. PTO Utility 1980)
  - C** 45 TOUCH ACTIVATED AC, FULL WAVE, TWO WIRE SWITCHES, US PAT 3549909 Assignee: HALL?BARKAN INSTRUMENTS, INC., (U.S. PTO Utility 1970)
  - H** 46 TOUCH-CONTROL ADAPTER FOR ELECTRIC LAMPS, US PAT 4211959 Assignee: Westek Corporation, (U.S. PTO Utility 1980)
  - C** 47 TOUCH CONTROL FOR ELECTRICAL APPARATUS, US PAT 3641410 Assignee: BLACK \$#amp;#amp; DECKER INC., (U.S. PTO Utility 1972)
  - C** 48 TOUCH CONTROL SWITCH, US PAT 4289972 (U.S. PTO Utility 1981)
  - C** 49 TOUCH CONTROL SWITCH, US PAT 4264831 (U.S. PTO Utility 1981)
  - C** 50 TOUCH CONTROL SWITCH, US PAT 4210822 (U.S. PTO Utility 1980)
  - C** 51 TOUCH CONTROL SWITCH CIRCUIT, US PAT 4731548 Assignee: Nartron Corporation, (U.S. PTO Utility 1988)
  - C** 52 TOUCH CONTROL SYSTEM, US PAT 5572205 Assignee: Donnelly Technology, Inc., (U.S. PTO Utility 1996)
  - C** 53 TOUCH CONTROLLED DISPLAY DEVICE, US PAT 4910504 Assignee: Touch Display Systems AB, (U.S. PTO Utility 1990)
  - C** 54 TOUCH CONTROLLED ELECTRIC LIGHT SOCKET WITH HIGH CURRENT TOLERANCE, US PAT 5208516 (U.S. PTO Utility 1993)

© 2014 Thomson Reuters. All rights reserved.

- 55 TOUCH LAMP, LATCHING AC SOLID STATE TOUCH SWITCH USABLE WITH SUCH LAMP, AND CIRCUITS FOR THE SAME, US PAT 3899713 Assignee: HALL BARKAN INSTRUMENTS, INC., (U.S. PTO Utility 1975)
- 56 TOUCH OVERLAY FOR IMPROVED TOUCH SENSITIVITY, US PAT 5386219 Assignee: International Business Machines Corp., (U.S. PTO Utility 1995)
- 57 TOUCH RESPONSIVE POWER CONTROL SYSTEM, US PAT 4939382 (U.S. PTO Utility 1990)
- 58 TOUCH-RESPONSIVE SOCKET, US PAT 4101805 Assignee: Destron, Inc., (U.S. PTO Utility 1978)
- 59 TOUCH SENSITIVE CONTROL PANEL, US PAT 5012124 (U.S. PTO Utility 1991)
- 60 TOUCH SENSITIVE ELECTRIC SWITCH, US PAT 4289980 (U.S. PTO Utility 1981)
- 61 TOUCH SENSITIVE ELECTRONIC SWITCH, US PAT 3879618 Assignee: MAGIC DOT, INC., (U.S. PTO Utility 1975)
- 62 TOUCH SENSITIVE POWER CONTROL CIRCUIT, US PAT 3666988 Assignee: ROBERT E BELLIS, (U.S. PTO Utility 1972)
- 63 TOUCH SENSITIVE POWER CONTROL SYSTEM, US PAT 3919596 Assignee: BELLIS ROBERT ELLIOTT, (U.S. PTO Utility 1975)
- 64 TOUCH SENSITIVE SWITCH, US PAT 4360737 Assignee: Leviton Manufacturing Co., Inc., (U.S. PTO Utility 1982)
- 65 TOUCH SWITCH CIRCUITS, US PAT 4119864 Assignee: RCA Corporation, (U.S. PTO Utility 1978)
- 66 TOUCH SWITCH DEVICE, US PAT 4352141 Assignee: Starcote Limited, (U.S. PTO Utility 1982)
- 67 TOUCH TERMINAL WITH RELIABLE PAD SELECTION, US PAT 4374381 Assignee: Interaction Systems, Inc., (U.S. PTO Utility 1983)

---

**US District Court Civil Docket**

U.S. District - Michigan Western  
(Southern Division 1)

**1:10cv691**

**Nartron Corporation et al v. Hourmand**

**This case was retrieved from the court on Sunday, January 26, 2014**

---

Date Filed: <b>07/20/2010</b>	Class Code: <b>CLOSED</b>
Assigned To: <b>Judge Robert Holmes Bell</b>	Closed: <b>09/08/2010</b>
Referred To:	Statute: <b>28:1338</b>
Nature of suit: <b>Patent (830)</b>	Jury Demand: <b>None</b>
Cause: <b>Patent Infringement</b>	Demand Amount: <b>\$0</b>
Lead Docket: <b>None</b>	NOS Description: <b>Patent</b>
Other Docket: <b>None</b>	
Jurisdiction: <b>Federal Question</b>	

**Litigants**

**Attorneys**

Nartron Corporation  
Plaintiff

Robert C.J. Tuttle  
ATTORNEY TO BE NOTICED  
Brooks Kushman PC  
1000 Town Ctr., 22nd Fl.  
Southfield, MI 48075-1238  
USA  
(248) 358-4400  
Fax: (248) 358-3351  
Email: Rtuttle@brookskushman.Com

Uusi, Llc  
Plaintiff

Robert C.J. Tuttle  
ATTORNEY TO BE NOTICED  
Brooks Kushman PC  
1000 Town Ctr., 22nd Fl.  
Southfield, MI 48075-1238  
USA  
(248) 358-4400  
Fax: (248) 358-3351  
Email: Rtuttle@brookskushman.Com

Byron Hourmand  
Defendant

Date	#	Proceeding Text	Source
07/20/2010	1	COMPLAINT against Byron Hourmand filed by Nartron Corporation, UUSI, LLC (Attachments: # 1 Exhibit A, # 2 Exhibit B, # 3 Exhibit C, # 4 Exhibit D, # 5 Exhibit E, # 6 Exhibit F, # 7 Exhibit G, # 8 Exhibit H, # 9 Exhibit I, # 10 Exhibit J, # 11 Exhibit K, # 12 Civil Cover Sheet)(rmw) (Entered: 07/21/2010)	

07/20/2010 RECEIPT: in the amount of \$350.00, receipt number GR020949; for filing fees (rmw) (Entered: 07/21/2010)

07/20/2010 SUMMONS ISSUED as to defendant Byron Hourmand (rmw) (Entered: 07/21/2010)

07/20/2010 2 CORPORATE DISCLOSURE STATEMENT by Nartron Corporation (rmw) (Entered: 07/21/2010)

07/20/2010 3 CORPORATE DISCLOSURE STATEMENT by UUSI, LLC (rmw) (Entered: 07/21/2010)

07/21/2010 4 REPORT from the Clerk, WDMI, to the Director of the U.S. Patent and Trademark Office on the filing of a PATENT ACTION (rmw) (Entered: 07/21/2010)

08/16/2010 5 SUMMONS returned executed; Byron Hourmand served on 8/4/2010, answer due 8/25/2010 (Brandenburg, Robert) (Entered: 08/16/2010)

08/16/2010 6 SUMMONS returned executed; Byron Hourmand served on 7/27/2010, answer due 8/25/2010 (Brandenburg, Robert) (Entered: 08/16/2010)

09/01/2010 7 UNOPPOSED MOTION to approve consent judgment by plaintiffs Nartron Corporation, UUSI, LLC; (Tuttle, Robert) (Entered: 09/01/2010)

09/08/2010 8 ORDER granting 7 motion to approve consent judgment ; signed by Judge Robert Holmes Bell (Judge Robert Holmes Bell, kcb) (Entered: 09/08/2010)

09/09/2010 9 REPORT from the Clerk, WDMI, to the Director of the U.S. Patent and Trademark Office on the determination of a PATENT ACTION (gjf) (Entered: 09/09/2010)

---

Copyright © 2014 LexisNexis CourtLink, Inc. All rights reserved.  
\*\*\* THIS DATA IS FOR INFORMATIONAL PURPOSES ONLY \*\*\*

**US District Court Civil Docket**

U.S. District - Pennsylvania Middle  
(Harrisburg)

**1:06cv1777**

**Org, Ltd., A/ K/ A Quantum Research Group, Ltd. v. Nartron Corporation**

**This case was retrieved from the court on Sunday, January 26, 2014**

Date Filed: <b>09/12/2006</b>	
Assigned To: <b>Honorable Sylvia H. Rambo</b>	
Referred To:	Class Code: <b>CLOSED</b>
Nature of suit: <b>Patent (830)</b>	Closed: <b>11/28/2007</b>
Cause: <b>Declaratory Judgement</b>	Statute: <b>28:2201</b>
Lead Docket: <b>None</b>	Jury Demand: <b>Both</b>
Other <b>U.S. District Court, Western Docket: District of PA, 2:06-CV-500</b>	Demand Amount: <b>\$0</b>
Jurisdiction: <b>Federal Question</b>	NOS Description: <b>Patent</b>

**Litigants**

**Attorneys**

Org, Ltd.  
a/k/a Quantum Research Group, Ltd.  
Plaintiff

Andrew E. Falsetti  
LEAD ATTORNEY; ATTORNEY TO BE NOTICED  
[Term: 10/23/2007]  
Reed Smith LLP  
435 Sixth Avenue  
Pittsburgh, PA 15219  
USA  
412-288-3844  
Email: Afalsetti@reedsmith.Com

Clay P. Hughes  
LEAD ATTORNEY; ATTORNEY TO BE NOTICED  
Reed Smith  
435 Sixth Avenue  
Pittsburgh, PA 15219  
USA  
412.288.3008  
Email: Chughes@reedsmith.Com

Gene A. Tabachnick  
LEAD ATTORNEY; ATTORNEY TO BE NOTICED  
Reed Smith LLP  
435 Sixth Avenue  
Pittsburgh, PA 15219  
USA  
412-288-3258  
Email: Gtabachnick@reedsmith.Com

Robert B. Hoffman

Nartron Corporation  
Defendant

LEAD ATTORNEY; ATTORNEY TO BE NOTICED  
Eckert Seamans Cherin & Mellott, LLC  
213 Market Street, 8th Floor  
Harrisburg , PA 17101  
USA  
(717) 237-7182  
Email: Rhoffman@eckertseamans.Com

Mark D. Chuey  
LEAD ATTORNEY; ATTORNEY TO BE NOTICED  
Brooks Kushman P.C.  
1000 Town Center 22nd Floor  
Southfield , MI 48075-1238  
USA  
248-358-4400  
Email: Mchuey@brookskushman.Com

Mark A. Grace  
LEAD ATTORNEY; ATTORNEY TO BE NOTICED  
Cohen & Grigsby PC  
11 Stanwix Street 15th Floor  
Pittsburgh , PA 15222-1319  
USA  
412-297-4900  
Email: Mgrace@cohenlaw.Com

Robert C.J. Tuttle  
LEAD ATTORNEY; ATTORNEY TO BE NOTICED  
Brooks Kushman P.C.  
1000 Town Center 22nd Floor  
Southfield , MI 48075-1238  
USA  
248-358-4400  
Email: Rtuttle@brookskushman.Com

Thomas C. Wettach  
LEAD ATTORNEY; ATTORNEY TO BE NOTICED  
Cohen & Grigsby, PC  
11 Stanwix Street 15th Floor  
Pittsburgh , PA 15222  
USA  
412-297-4900  
Email: Twettach@cohenlaw.Com

Jill L. Bradley  
ATTORNEY TO BE NOTICED  
Cohen & Grigsby, P.C.  
625 Liberty Avenue  
Pittsburgh , PA 15222-3152  
USA  
412-297-4707  
Email: Jbradley@cohenlaw.Com

Nartron Corporation  
Counterclaim Plaintiff

Mark D. Chuey  
LEAD ATTORNEY; ATTORNEY TO BE NOTICED  
Brooks Kushman P.C.  
1000 Town Center 22nd Floor  
Southfield , MI 48075-1238  
USA

248-358-4400  
Email: Mchuey@brookskushman.Com

Mark A. Grace  
LEAD ATTORNEY; ATTORNEY TO BE NOTICED  
Cohen & Grigsby PC  
11 Stanwix Street 15th Floor  
Pittsburgh , PA 15222-1319  
USA  
412-297-4900  
Email: Mgrace@cohenlaw.Com

Robert C.J. Tuttle  
LEAD ATTORNEY; ATTORNEY TO BE NOTICED  
Brooks Kushman P.C.  
1000 Town Center 22nd Floor  
Southfield , MI 48075-1238  
USA  
248-358-4400  
Email: Rtuttle@brookskushman.Com

Thomas C. Wettach  
LEAD ATTORNEY; ATTORNEY TO BE NOTICED  
Cohen & Grigsby, PC  
11 Stanwix Street 15th Floor  
Pittsburgh , PA 15222  
USA  
412-297-4900  
Email: Twettach@cohenlaw.Com

Jill L. Bradley  
ATTORNEY TO BE NOTICED  
Cohen & Grigsby, P.C.  
625 Liberty Avenue  
Pittsburgh , PA 15222-3152  
USA  
412-297-4707  
Email: Jbradley@cohenlaw.Com

Qrg, Ltd.  
Counterclaim Defendant

Andrew E. Falsetti  
LEAD ATTORNEY; ATTORNEY TO BE NOTICED  
[Term: 10/23/2007]  
Reed Smith LLP  
435 Sixth Avenue  
Pittsburgh , PA 15219  
USA  
412-288-3844  
Email: Afalsetti@reedsmith.Com

Clay P. Hughes  
LEAD ATTORNEY; ATTORNEY TO BE NOTICED  
Reed Smith  
435 Sixth Avenue  
Pittsburgh , PA 15219  
USA  
412.288.3008  
Email: Chughes@reedsmith.Com

Gene A. Tabachnick  
LEAD ATTORNEY; ATTORNEY TO BE NOTICED



Reed Smith LLP  
 435 Sixth Avenue  
 Pittsburgh , PA 15219  
 USA  
 412-288-3258  
 Email: Gtabachnick@reedsmith.Com

Robert B. Hoffman  
 LEAD ATTORNEY; ATTORNEY TO BE NOTICED  
 Eckert Seamans Cherin & Mellott, LLC  
 213 Market Street, 8th Floor  
 Harrisburg , PA 17101  
 USA  
 (717) 237-7182  
 Email: Rhoffman@eckertseamans.Com

Date	#	Proceeding Text	Source
09/12/2006	1	Case transferred in from District of Western District of Pennsylvania; Case Number 2:06-CV-500. Original file with documents numbered 1-17, certified copy of transfer order and docket sheet received., filed by QRG, LTD.. (Attachments: # 1 Civil Cover Sheet # 2 Receipt# 3 Doc. 2- Disclosure Statement# 4 Doc. 3- Summons# 5 Doc. 4- Motion to Dismiss# 6 Proposed Order to Motion to Dismiss# 7 Doc. 5- Brief in Support to Motion to Dismiss# 8 Exhibit A# 9 Exhibit B# 10 Exhibit C# 11 Doc. 6- Notice of Appearance by Thomas C. Wettach# 12 Doc. 7- Notice; Response to Motion to Dismiss# 13 Doc. 8- Motion for Discovery# 14 Proposed Order for Motion for Discovery# 15 Exhibit 1# 16 Exhibit 2# 17 Exhibit 3# 18 Exhibit 4# 19 Exhibit 6# 20 Exhibit 7# 21 Exhibit 8# 22 Exhibit 9# 23 Exhibit 5 (Motion for Discovery)# 24 Doc. 9- Notice: Response to Motion for Discovery# 25 Doc. 10- Brief in Opp. to Motion for Discovery# 26 Exhibit A (Brief in Opp. to Discovery)# 27 Exhibit B (Brief in Opp. to Discovery)# 28 Exhibit C (Brief in Opp. for Discovery)# 29 Exhibit D- (Brief in Opp. to Discovery)# 30 Doc. 11- Order Granting Motion for Discovery# 31 Doc. 12- Brief in Opp. to Motion to Dismiss# 32 Exhibit A (Brief in Opp. to Motion to Dismiss)# 33 Exhibit B (Brief in Opp. to Motion to Dismiss)# 34 Exhibit C (Brief in Opp. to Motion to Dismiss)# 35 Declaration of Richard T. Ting# 36 Declaration of Andrew E. Falsetti# 37 Declaration of Harald Philipp# 38 Declaration of Chris Bede# 39 Doc. 3 - Motion for Leave to File a Brief in Reply# 40 Exhibit A (Motion to File Brief in Reply)# 41 Doc. 14- Response to Motion for Leave to File a Brief in Reply# 42 Supplemental Declaration of Richard Ting# 43 Doc. 15-Order Granting Motion to File Brief in Reply# 44 Doc. 16- Brief in Reply# 45 Exhibit A (Brief in Reply)# 46 Doc. 17- Order Denying Motion to Dismiss. ADDITIONAL ATTACHMENTS ADDED-TRANSFER LETTER AND DOCKET FROM WESTERN DISTRICT OF PA(s) added on 9/13/2006 (crh, ). (Entered: 09/13/2006)	
09/13/2006		SPECIAL ADMISSION FORM SENT to Andrew E. Falsetti, Mark A. Grace & Thomas C. Wettach (crh, ) (Entered: 09/13/2006)	
09/13/2006	2	Transfer Letter to Counsel (crh, ) (Entered: 09/13/2006)	
09/20/2006	3	NOTICE:A Case Mgmt Conf has been set for 10/24/2006 @ 9:15 AM before Honorable Sylvia H. Rambo. This conference is by phone and the call is to initiated by the pltf. unless otherwise agreed upon. A joint case mgmnt plan is to be filed n/l/t 10/17/06.(ma, ) (Entered: 09/20/2006)	
09/21/2006	4	PETITION FOR SPECIAL ADMISSION (PRO HAC VICE) by Andrew E. Falsetti on behalf of QRG, LTD. Attorney Andrew E. Falsetti is seeking special admission. Filing Fee: 25.00 Receipt Number: 111 146455 (Attachments: # 1 Receipt) (jc) (Entered: 09/21/2006)	

- 09/21/2006 5 PETITION FOR SPECIAL ADMISSION (PRO HAC VICE) by Gene A. Tabachnick on behalf of QRG, LTD. Attorney Gene A. Tabachnick is seeking special admission. Filing Fee: 25.00 Receipt Number: 111 146455 (Attachments: # 1 Receipt) (jc) (Entered: 09/21/2006)
- 09/21/2006 6 NOTICE of Appearance by Robert B. Hoffman on behalf of QRG, LTD. (Hoffman, Robert) (Entered: 09/21/2006)
- 09/22/2006 7 SPECIAL ADMISSIONS FORM APPROVED as to Andrew Falsetti, Esq. on behalf of ORG, LTDSigned by Judge Sylvia H. Rambo on 09/22/06. (ma, ) (Entered: 09/22/2006)
- 09/22/2006 8 SPECIAL ADMISSIONS FORM APPROVED as to Gene Tabachnick, Esq. on behalf of QRG, LTDSigned by Judge Sylvia H. Rambo on 09/22/06. (ma, ) (Entered: 09/22/2006)
- 09/29/2006 9 PETITION FOR SPECIAL ADMISSION (PRO HAC VICE) by Mark D. Chuey on behalf of NARTRON CORPORATION Attorney Mark D. Chuey is seeking special admission. Filing Fee: 25.00 Receipt Number: 111 146486 (crh, ) (Entered: 09/29/2006)
- 09/29/2006 10 PETITION FOR SPECIAL ADMISSION (PRO HAC VICE) by Robert C.J. Tuttle on behalf of NARTRON CORPORATION Attorney Robert C.J. Tuttle is seeking special admission. Filing Fee: 25.00 Receipt Number: 111 146485. (crh, ) (Entered: 09/29/2006)
- 10/02/2006 11 SPECIAL ADMISSIONS FORM APPROVED as to Mark D. Chuey, Esq. on behalf of Nartron/Signed by Judge Sylvia H. Rambo on 10/02/06. (ma, ) (Entered: 10/02/2006)
- 10/02/2006 12 SPECIAL ADMISSIONS FORM APPROVED as to Robert Tuttle, Esq. on behalf of Nartron.Signed by Judge Sylvia H. Rambo on 10/02/06. (ma, ) (Entered: 10/02/2006)
- 10/06/2006 13 ANSWER to Complaint by NARTRON CORPORATION. (Attachments: # 1 Exhibit(s) A# 2 Exhibit(s) B)(Bradley, Jill) (Entered: 10/06/2006)
- 10/17/2006 14 CASE MANAGEMENT PLAN by QRG, LTD.. (Falsetti, Andrew) (Entered: 10/17/2006)
- 10/18/2006 15 PETITION FOR SPECIAL ADMISSION (PRO HAC VICE) by Mark A. Grace on behalf of NARTRON CORPORATION Attorney Mark A. Grace is seeking special admission. Filing Fee: 25.00 Receipt Number: 111 146621. (crh, ) (Entered: 10/18/2006)
- 10/18/2006 16 PETITION FOR SPECIAL ADMISSION (PRO HAC VICE) by Thomas C. Wettach on behalf of NARTRON CORPORATION Attorney Thomas C. Wettach is seeking special admission. Filing Fee: 25.00 Receipt Number: 111 146621. (crh, ) (Entered: 10/18/2006)
- 10/19/2006 17 SPECIAL ADMISSIONS FORM APPROVED as to Mark Grace, Esq. on behalf of NartronSigned by Judge Sylvia H. Rambo on 10/19/06. (ma, ) (Entered: 10/19/2006)
- 10/19/2006 18 SPECIAL ADMISSIONS FORM APPROVED as to Thomas Wettach, Esq. on behalf of NartronSigned by Judge Sylvia H. Rambo on 10/19/06. (ma, ) (Entered: 10/19/2006)
- 10/24/2006 20 ORDER - STANDARD CASE MANAGEMENT TRACK Case placed on the 08/2007 trial list. Cases on this list are scheduled to begin on 9/4/2007 following all j/s's starting at 9:30 AM. A date certain may be discussed at the PTC which is set for 8/17/2007 @ 1:30 PM; Discovery due by 2/28/2007. Dispositive Mtns due by 6/20/2007. PTMs due by 8/10/2007. See order for other ddls. Signed by Judge Sylvia H. Rambo on 10/24/06. (ma, ) (Entered: 10/24/2006)
- 11/01/2006 21 MOTION to Dismiss Pursuant to Fed.R.Civ.P. 12(b)(1) by NARTRON CORPORATION. (Attachments: # 1 Certificate of Compliance With Local Rule 7.1# 2 Proposed Order)(Grace, Mark) (Entered: 11/01/2006)

- 11/01/2006 22 BRIEF IN SUPPORT re 21 MOTION to Dismiss Pursuant to Fed.R.Civ.P. 12(b)(1) filed by NARTRON CORPORATION. (Attachments: # 1 Declaration of John E. Nemazi# 2 Exhibit(s) A - G)(Grace, Mark) (Entered: 11/01/2006)
- 11/16/2006 23 BRIEF IN OPPOSITION re 21 MOTION to Dismiss Pursuant to Fed.R.Civ.P. 12(b)(1) filed by QRG, LTD.. (Attachments: # 1 Affidavit / Declaration of Harald Philipp# 2 Exhibit(s) 1# 3 Exhibit(s) 2# 4 Exhibit(s) 3# 5 Exhibit(s) 4# 6 Exhibit(s) 5# 7 Exhibit(s) 6# 8 Exhibit(s) 7)(Falsetti, Andrew) (Entered: 11/16/2006)
- 11/27/2006 24 REPLY BRIEF re 21 MOTION to Dismiss Pursuant to Fed.R.Civ.P. 12(b)(1) filed by NARTRON CORPORATION. (Attachments: # 1 Exhibit(s) 1)(Grace, Mark) (Entered: 11/27/2006)
- 11/30/2006 25 MOTION to Clarify The Case Caption by QRG, LTD.. (Attachments: # 1 Certificate of Compliance with Local Rule 7.1# 2 Proposed Order)(Falsetti, Andrew) (Entered: 11/30/2006)
- 12/01/2006 26 BRIEF IN SUPPORT re 25 MOTION to Clarify The Case Caption filed by QRG, LTD..(Falsetti, Andrew) (Entered: 12/01/2006)
- 12/01/2006 27 ORDER deferring ruling on Motion to Clarify 25 pending decision on dft's mtn to dismissSigned by Judge Sylvia H. Rambo on 12/01/06 (ma, ) (Entered: 12/01/2006)
- 02/12/2007 29 NOTICE by QRG, LTD. of Dismissal of Related Action (Attachments: # 1 Appendix Eastern District of Michigan Order and Opinion Granting Motion to Dismiss)(Falsetti, Andrew) (Entered: 02/12/2007)
- 03/02/2007 30 MEMORANDUM AND ORDER: Denying in part dft's mtn to dismiss 21 as follows: a) The Court will reserve ruling with regard to the "capacitivetouch sensor products and related components" issue and grant Pltf lv to amend the complaint on or before 4/2/07.b) Mtn is denied in all other respects.2) Pltf's Mtn to Clarify the Case Caption 25 is GRANTED. The Clrk shall change the case caption as to pltf to read: "QRG, Ltd., a/k/a Quantum Research Group, Ltd., Plaintiff." All future filings shall display this caption. 3) An amended cmo will follow.Signed by Judge Sylvia H. Rambo on 03/02/07 (ma, ) (Entered: 03/02/2007)
- 03/02/2007 31 AMENDED CASE MANAGEMENT ORDER: J/S and Trial continued to the 10/1/2007 list beginning at 9:30 AM before Honorable Sylvia H. Rambo. Discovery due by 3/30/2007. Dispositive Mts ddl 7/20/2007. PTMs due by 9/7/2007. PTC rescheduled for 9/14/2007 @ 10:00 AM before Honorable Sylvia H. Rambo. See order for other ddls.Signed by Judge Sylvia H. Rambo on 03/02/07. (ma, ) (Entered: 03/02/2007)
- 03/08/2007 32 AMENDED COMPLAINT against NARTRON CORPORATION, filed by QRG, LTD..(Falsetti, Andrew) (Entered: 03/08/2007)
- 03/19/2007 33 ANSWER to Amended Complaint, COUNTERCLAIM against all defendants by NARTRON CORPORATION.(Grace, Mark) (Entered: 03/19/2007)
- 03/20/2007 Correction made to docket sheet to reflect QRG, LTD. as the Counterclaim Defendant with appropriate counsel listed as per the 3/19/07 Amended Complaint and Counterclaim 33 . (dfm ) (Entered: 03/20/2007)
- 03/23/2007 34 MOTION to Strike Counterclaim by QRG, LTD.. (Attachments: # 1 Exhibit(s) A# 2 Exhibit(s) B# 3 Exhibit(s) C# 4 Exhibit(s) D# 5 Brief in Support# 6 Proposed Order)(Falsetti, Andrew) (Entered: 03/23/2007)
- 03/26/2007 35 BRIEF IN SUPPORT re 34 MOTION to Strike Counterclaim filed by QRG, LTD..(Falsetti, Andrew) (Entered: 03/26/2007)
- 03/29/2007 36 REPLY BRIEF re 34 MOTION to Strike Counterclaim filed by NARTRON CORPORATION. (Attachments: # 1 Exhibit(s) A# 2 Exhibit(s) B# 3 Exhibit(s) C - Part 1# 4 Exhibit(s) C - Part 2# 5 Exhibit(s) D# 6 Exhibit(s) E# 7 Exhibit(s) F# 8 Exhibit(s) G# 9 Exhibit(s) H# 10 Exhibit(s) I)(Grace, Mark) (Entered: 03/29/2007)

- 03/29/2007 37 CERTIFICATE of of Compliance by NARTRON CORPORATION re 36 Reply Brief,. (Grace, Mark) (Entered: 03/29/2007)
- 04/12/2007 38 REPLY BRIEF re 34 MOTION to Strike Counterclaim filed by QRG, LTD.. (Falsetti, Andrew) (Entered: 04/12/2007)
- 04/23/2007 39 MEMORANDUM AND ORDER denying pltf's Motion to Strike 34 .Signed by Judge Sylvia H. Rambo on 04/23/07 (ma, ) (Entered: 04/23/2007)
- 04/23/2007 40 NOTICE: A scheduling Conference has been scheduled for 5/10/2007 @ 9:00 AM before Honorable Sylvia H. Rambo. This conference is by phone with the call to be initiated by the pltf.Signed by Judge Sylvia H. Rambo on 04/23/07. (ma, ) (Entered: 04/23/2007)
- 05/07/2007 41 REPLY/ ANSWER to Counterclaim for Patent Infringement by QRG, LTD.. (Falsetti, Andrew) (Entered: 05/07/2007)
- 05/07/2007 42 MOTION for Partial Summary Judgment on Plaintiff QRG's Declaratory Judgment Claim for Unenforceability of The Five Nartron Patents-In-Suit by NARTRON CORPORATION.(Grace, Mark) (Entered: 05/07/2007)
- 05/07/2007 43 STATEMENT OF FACTS re 42 MOTION for Partial Summary Judgment on Plaintiff QRG's Declaratory Judgment Claim for Unenforceability of The Five Nartron Patents-In-Suit filed by NARTRON CORPORATION. (Attachments: # 1 Index of Exhibits# 2 Exhibit(s) A# 3 Exhibit(s) B# 4 Exhibit(s) C) (Grace, Mark) (Entered: 05/07/2007)
- 05/07/2007 44 BRIEF IN SUPPORT re 42 MOTION for Partial Summary Judgment on Plaintiff QRG's Declaratory Judgment Claim for Unenforceability of The Five Nartron Patents-In-Suit filed by NARTRON CORPORATION.(Grace, Mark) (Entered: 05/07/2007)
- 05/07/2007 45 EXHIBIT A to Brief in Support by NARTRON CORPORATION re 44 Brief in Support. (Grace, Mark) (Entered: 05/07/2007)
- 05/07/2007 46 EXHIBIT PROPOSED ORDER by NARTRON CORPORATION re 42 MOTION for Partial Summary Judgment on Plaintiff QRG's Declaratory Judgment Claim for Unenforceability of The Five Nartron Patents-In-Suit. (Grace, Mark) (Entered: 05/07/2007)
- 05/07/2007 47 MOTION for Partial Summary Judgment that the Nartron Patents-In-Suit Are Not Invalid by NARTRON CORPORATION. (Attachments: # 1 Proposed Order)(Grace, Mark) (Entered: 05/07/2007)
- 05/07/2007 48 STATEMENT OF FACTS re 47 MOTION for Partial Summary Judgment that the Nartron Patents-In-Suit Are Not Invalid filed by NARTRON CORPORATION. (Attachments: # 1 Index# 2 Exhibit(s) A# 3 Exhibit(s) B# 4 Exhibit(s) C# 5 Exhibit(s) D# 6 Exhibit(s) E)(Grace, Mark) (Entered: 05/07/2007)
- 05/07/2007 49 BRIEF IN SUPPORT re 47 MOTION for Partial Summary Judgment that the Nartron Patents-In-Suit Are Not Invalid filed by NARTRON CORPORATION. (Attachments: # 1 Exhibit(s) A)(Grace, Mark) (Entered: 05/07/2007)
- 05/08/2007 50 CERTIFICATE of Compliance with Word-Count Limit by NARTRON CORPORATION re 44 Brief in Support. (Grace, Mark) (Entered: 05/08/2007)
- 05/08/2007 51 CERTIFICATE of Compliance with Word-Count Limit by NARTRON CORPORATION re 49 Brief in Support. (Grace, Mark) (Entered: 05/08/2007)
- 05/08/2007 Pursuant to the Local Rules and ECF User Manual, all motions and briefs should be filed simultaneously with their corresponding proposed orders, exhibits and any certificates as attachments to the main documents and not as individual documents. (dfm ) (Entered: 05/08/2007)
- 05/10/2007 54 ORDER: 1) The fact discovery ddl shall be ext'd to (90) daysfrom the date of this order;2) W/i (30) days of this order, the parties shall depose

Mr. Ingraham, an inventor; 3) W/i (30) days of this order, the parties shall jointly determine whether the issues and patents involved in this case can be narrowed; 4) A telephonic status conference shall take place on 6/26/07, at 9:30 a.m. Pltf shall initiate the call; 5) Briefing of Nartrons two partial mtns for sum jgm (Docs. 42 and 47 ) is STAYED until 8/17/07. On or before that date, Nartron shall notify the crt and QRG whether it intends to rely upon the mtns as they are, or withdraw the mtns and file a new dispositive mtn. If Nartron elects to file a new dispositive mtn, it must do so by 8/17/07. If Nartron leaves the mtns as they are, briefing will resume in accord w/LRs and QRGs responses will be due on or before 9/4/07; 6) The case management deadlines are amended as follows: Jury Selection/Trial Date December 3, 2007 @ 9:30 AM Fact Discovery Ddl 8/10/07; Amended Dispositive Mtns & Brsups 08/17/07; Pltfs Expert Reports 08/24/07; Dfts Expert Reports 09/7/07; Supplemental Reports 09/21/07; Mtns in Limine & Brsups 10/09/07; Mtns in Limine Response 10/19/07; Mtns in Limine Reply 10/26/07; P-T Conference 11/16/07 @ 11:00 AM; P-T Memoranda 11/9/07; Signed by Judge Sylvia H. Rambo on 05/10/07. (ma, ) (Entered: 05/10/2007)

- 06/14/2007 55 STATUS REPORT to the Court on Narrowing of Issues and Patents Involved, and Request for Order for Mandatory Rule 26(a)(1) Disclosures by the Parties by NARTRON CORPORATION. (Attachments: # 1 Exhibit(s) A# 2 Exhibit(s) B# 3 Exhibit(s) C# 4 Exhibit(s) D)(Grace, Mark) (Entered: 06/14/2007)
- 06/19/2007 56 ORDER: Pltf QRG, Ltd. a/k/a Quantum Research Group, Ltd. shall respond to the points and proposals set forth in Nartrons status report 55 and proposed order no later than July 9, 2007. Signed by Judge Sylvia H. Rambo on 06/19/07. (ma, ) (Entered: 06/19/2007)
- 07/09/2007 58 NOTICE by QRG, LTD. in Response to Nartron's Report and Proposed Order (Attachments: # 1 Word-Count Certificate# 2 Proposed Order # 3 Exhibit(s) 1# 4 Exhibit(s) 2# 5 Exhibit(s) 3# 6 Exhibit(s) 4# 7 Exhibit(s) 5# 8 Exhibit(s) 6# 9 Exhibit(s) 8# 10 Exhibit(s) 9# 11 Exhibit(s) 10# 12 Exhibit(s) 11# 13 Exhibit(s) 12# 14 Exhibit(s) 7)(Falsetti, Andrew) (Entered: 07/09/2007)
- 07/13/2007 59 RESPONSE by NARTRON CORPORATION to 58 Notice.. (Attachments: # 1 Exhibit(s) 1-4)(Grace, Mark) (Entered: 07/13/2007)
- 07/27/2007 60 Joint MOTION for Extension of Time to Complete Discovery by QRG, LTD.. (Attachments: # 1 Proposed Order)(Falsetti, Andrew) (Entered: 07/27/2007)
- 08/01/2007 61 MEMORANDUM AND ORDER: 1) The claims and counterclaim in the captioned case are limited to those involving QRGs QProx E2SR, QT110, QT113, QT9701, and QT1106 products, and Nartrons patents U.S. patents: 4,731,548; 4,758,735; 4,831,279; 5,087,825; 5,796,183. All other claims are DISMISSED for lack of subject matter jurisdiction. 2) Defendant Nartron Corporations Motion for Partial Summary Judgment on Plaintiff QRGs Declaratory Judgment Claim for Unenforceability of the Five Nartron Patents-in-Suit 42 and Motion for Partial Summary Judgment that the Nartron Patents-in-Suit are not Invalid 47 are STRICKEN. 3) Disposition of the parties Joint Motion to Revise Case Management Order 60 is deferred pending the outcome of mediation. 4) The parties shall notify the court no later than August 10, 2007, whether they intend to obtain their own mediator or request the court to appoint a mediator. 5) Mediation shall be completed no later than September 14, 2007. Signed by Judge Sylvia H. Rambo on 08/01/07 (ma, ) (Entered: 08/01/2007)
- 08/10/2007 62 NOTICE by QRG, LTD. and Nartron Corporation Regarding Mediator Selection (Falsetti, Andrew) (Entered: 08/10/2007)
- 09/26/2007 63 STATUS REPORT by NARTRON CORPORATION. (Grace, Mark) (Entered: 09/26/2007)

- 10/22/2007 64 STATUS REPORT (Joint) by NARTRON CORPORATION. (Grace, Mark)  
(Entered: 10/22/2007)
- 10/23/2007 65 PETITION FOR SPECIAL ADMISSION (PRO HAC VICE) by Clay P. Hughes  
on behalf of QRG, LTD. Attorney Clay Hughes is seeking special admission.  
Filing fee \$ 25, receipt number 1136392.. (Hughes, Clay) (Entered:  
10/23/2007)
- 10/23/2007 66 ATTORNEY SUBSTITUTION - Withdrawal and Entry of Attorney  
Appearance. Attorney Andrew E. Falsetti terminated. Attorney Clay P.  
Hughes and Clay P. Hughes for QRG, LTD. added. (Hughes, Clay)  
(Entered: 10/23/2007)
- 10/23/2007 67 SPECIAL ADMISSIONS FORM APPROVED as to Clay Hughes, Esq. on behalf  
of QRG Signed by Judge Sylvia H. Rambo on 10/23/07. (ma, ) (Entered:  
10/23/2007)
- 11/28/2007 68 STIPULATION of Dismissal with Prejudice by NARTRON CORPORATION.  
(Grace, Mark) (Entered: 11/28/2007)
- 11/28/2007 69 ORDER APPROVING STIPULATION OF DISMISSAL. Signed by all parties.  
Case termed.Signed by Judge Sylvia H. Rambo on 11/28/07. (ma, )  
(Entered: 11/28/2007)

---

Copyright © 2014 LexisNexis CourtLink, Inc. All rights reserved.  
\*\*\* THIS DATA IS FOR INFORMATIONAL PURPOSES ONLY \*\*\*

---

**US District Court Civil Docket**

U.S. District - Pennsylvania Western  
(Pittsburgh)

**2:06cv500**

**Org, Ltd. v. Nartron Corporation**

**This case was retrieved from the court on Sunday, January 26, 2014**

---

Date Filed: <b>04/13/2006</b>	Class Code: <b>CLOSED</b>
Assigned To: <b>Donetta W. Ambrose</b>	Closed: <b>09/07/2006</b>
Referred To:	Statute: <b>28:2201</b>
Nature of suit: <b>Patent (830)</b>	Jury Demand: <b>Plaintiff</b>
Cause: <b>Declaratory Judgment</b>	Demand Amount: <b>\$0</b>
Lead Docket: <b>None</b>	NOS Description: <b>Patent</b>
Other Docket: <b>None</b>	
Jurisdiction: <b>Federal Question</b>	

**Litigants**

**Attorneys**

Org, Ltd.  
Plaintiff

Andrew E. Falsetti  
LEAD ATTORNEY  
Reed Smith  
435 Sixth Avenue  
Pittsburgh , PA 15219-1886  
USA  
(412) 288-3844  
Fax: (412) 288-3063  
Email: Afalsetti@reedsmith.Com

Nartron Corporation  
Defendant

Mark A. Grace  
LEAD ATTORNEY; ATTORNEY TO BE NOTICED  
Cohen & Grace, LLC  
105 Braunlich Dr. Suite 300  
Pittsburgh , PA 15237  
USA  
(412) 680-1266  
Email: Mgrace@cohengrace.Com

Thomas C. Wettach  
LEAD ATTORNEY; ATTORNEY TO BE NOTICED  
Cohen & Grace LLC  
105 Braunlich Drive, Suite # 300  
Pittsburgh , PA 15237-3351  
USA  
(412) 847-0300  
Email: Twettach@cohengrace.Com

Date	#	Proceeding Text	Source
------	---	-----------------	--------

- 04/13/2006 1 COMPLAINT against NARTRON CORPORATION ( Filing fee \$ 350 receipt number 3312.) filed by QRG, LTD.. (Attachments: # 1 Civil Cover Sheet # 2 Receipt # 3312)(jsp) (Entered: 04/14/2006)
- 04/13/2006 2 Disclosure Statement by QRG, LTD. (jsp) (Entered: 04/14/2006)
- 04/14/2006 Summons Issued as to NARTRON CORPORATION. (jsp) (Entered: 04/14/2006)
- 04/14/2006 Remark: E-mail notification to the U.S. Patent and Trademark Office with complaint and docket entries attached sent this date. (jsp, ) (Entered: 04/14/2006)
- 04/24/2006 3 SUMMONS/ Return of Service Returned Executed by QRG, LTD.. NARTRON CORPORATION served on 4/18/2006, answer due 5/8/2006. (Tabachnick, Gene) (Entered: 04/24/2006)
- 05/08/2006 4 MOTION to Dismiss Pursuant to Fed.R.Civ.P. 12(b)(2) by NARTRON CORPORATION. (Attachments: # 1 Proposed Order (Grace, Mark) (Entered: 05/08/2006)
- 05/08/2006 5 BRIEF in Support re 4 MOTION to Dismiss Pursuant to Fed.R.Civ.P. 12(b)(2) filed by NARTRON CORPORATION. (Attachments: # 1 Exhibit A# 2 Exhibit B# 3 Exhibit C)(Grace, Mark) (Entered: 05/08/2006)
- 05/09/2006 6 NOTICE of Appearance by Thomas C. Wettach on behalf of NARTRON CORPORATION (Wettach, Thomas) (Entered: 05/09/2006)
- 05/09/2006 7 NOTICE: Response to Defendant's Motion to Dismiss (Docket No. 4) due by 5/30/2006. (jlh ) (Entered: 05/09/2006)
- 05/12/2006 8 MOTION for Discovery on Personal Jurisdiction by QRG, LTD.. (Attachments: # 1 Proposed Order # 2 Exhibit 1# 3 Exhibit 2# 4 Exhibit 3# 5 Exhibit 4# 6 Exhibit 5# 7 Exhibit 6# 8 Exhibit 7# 9 Exhibit 8# 10 Exhibit 9)(Falsetti, Andrew) (Entered: 05/12/2006)
- 05/22/2006 9 NOTICE: Response to Plaintiff's Motion for Leave to Take Discovery on the Personal Jurisdiction Issue Raised by Defendant's Motion to Dismiss shall be due by 5/29/2006. In addition, the Plaintiff's response to the Defendant's Motion to Dismiss shall be continued from May 30, 2006 until a date set forth in a future order of this court. (jlh) (Entered: 05/22/2006)
- 05/26/2006 10 BRIEF in Opposition re 8 MOTION for Discovery on Personal Jurisdiction filed by NARTRON CORPORATION. (Attachments: # 1 Exhibit A# 2 Exhibit B# 3 Exhibit C# 4 Exhibit D)(Grace, Mark) (Entered: 05/26/2006)
- 05/30/2006 11 ORDER granting 8 Motion for Discovery ( as stated more fully in order). Signed by Judge Donetta W. Ambrose on 5/30/06. (jlh) (Entered: 05/30/2006)
- 05/30/2006 Response to Motion to Dismiss due by 7/30/2006. (jlh) (Entered: 05/30/2006)
- 07/31/2006 12 BRIEF in Opposition re 4 MOTION to Dismiss Pursuant to Fed.R.Civ.P. 12(b)(2) filed by QRG, LTD.. (Attachments: # 1 Exhibit A# 2 Exhibit B# 3 Exhibit C# 4 Affidavit /Declaration of Richard T. Ting in Support of Qrg's Oppostion to Defendant's Motion to Dismiss# 5 Affidavit /Declaration of Andrew E. Falsetti in Support of Qrg's Oppostion to Defendant's Motion to Dismiss# 6 Affidavit /Declaration of Harald Philipp in Support of Qrg's Oppostion to Defendant's Motion to Dismiss# 7 Affidavit /Declaration of Chris Bede in Support of QRG's Oppostion to Defendant's Motion to Dismiss)(Falsetti, Andrew) (Entered: 07/31/2006)
- 08/04/2006 13 MOTION for Leave to File A Brief in Reply to Plaintiff QRG's Opposition to Defendant's Motion to Dismiss by NARTRON CORPORATION. (Attachments: # 1 Exhibit A)(Grace, Mark) (Entered: 08/04/2006)
- 08/07/2006 14 RESPONSE to Motion re 13 MOTION for Leave to File A Brief in Reply to Plaintiff QRG's Opposition to Defendant's Motion to Dismiss filed by QRG,



- LTD.. (Attachments: # 1 Affidavit /Supplemental Declaration of Richard T. Ting)(Falsetti, Andrew) (Entered: 08/07/2006)
- 08/09/2006 15 ORDER granting 13 Motion for Leave to File Reply Brief . Signed by Judge Donetta W. Ambrose on 8/8/06. (jlh ) (Entered: 08/09/2006)
- 08/09/2006 16 BRIEF IN REPLY to Response to Motion re 4 MOTION to Dismiss Pursuant to Fed.R.Civ.P. 12(b)(2) filed by NARTRON CORPORATION. (Attachments: # 1 Exhibit A)(Grace, Mark) Modified text to reflect title of document on 8/10/2006 (jsp, ). (Entered: 08/09/2006)
- 09/07/2006 17 ORDER denying 4 Motion to Dismiss, as set forth more fully in the Opinion accompanying this Order; It is further ORDERED that the within case is transferred to the United States District Court for the Middle District of Pennsylvania. The Clerk of Court is directed to transfer this case forthwith to the U.S. District Court for the Middle District of Pennsylvania. Signed by Judge Donetta W. Ambrose, Chief Judge, on 09/07/2006. (adb) (Entered: 09/07/2006)
- 09/07/2006 Case transferred to District of USDC Middle District of PA. Original file, certified copy of transfer order, retrieval instructions and docket sheet sent. (jsp) (Entered: 09/07/2006)
- 09/07/2006 Remark: E-mail notification to the U.S. Patent and Trademark Office with copy of order transferring this action to the USDC for the Middle District of Pennsylvania sent on September 7, 2006. (jsp) (Entered: 09/07/2006)

---

Copyright © 2014 LexisNexis CourtLink, Inc. All rights reserved.  
\*\*\* THIS DATA IS FOR INFORMATIONAL PURPOSES ONLY \*\*\*

**US District Court Civil Docket**

U.S. District - Michigan Eastern  
(Detroit)

**2:03cv75169**

**Nartron Corp v. Gen Elec, et al**

This case was retrieved from the court on Sunday, January 26, 2014

Date Filed: <b>12/24/2003</b>	
Assigned To: <b>District Judge Nancy G. Edmunds</b>	Class Code: <b>CLOSED</b>
Referred To: <b>Magistrate Judge Virginia M. Morgan</b>	Closed: <b>02/14/2005</b>
Nature of suit: <b>Patent (830)</b>	Statute:
Cause:	Jury Demand: <b>Both</b>
Lead Docket: <b>None</b>	Demand Amount: <b>\$0</b>
Other Docket: <b>None</b>	NOS Description: <b>Patent</b>
Jurisdiction: <b>Federal Question</b>	

**Litigants**

**Attorneys**

Nartron Corporation  
Plaintiff

Ernie L. Brooks - INACTIVE  
LEAD ATTORNEY; ATTORNEY TO BE NOTICED  
Brooks Kushman  
1000 Town Center 22nd Floor  
Southfield , MI 48075  
USA  
248-358-4400

John E. Nemazi  
LEAD ATTORNEY; ATTORNEY TO BE NOTICED  
Brooks Kushman  
1000 Town Center 22nd Floor  
Southfield , MI 48075  
USA  
248-358-4400  
Email: Jnemazi@brookskushman.Com

Sangeeta G. Shah  
LEAD ATTORNEY; ATTORNEY TO BE NOTICED  
Brooks Kushman  
1000 Town Center 22nd Floor  
Southfield , MI 48075  
USA  
248-358-4400  
Email: Sshah@brookskushman.Com

Thomas W. Cunningham

General Electric  
Defendant

LEAD ATTORNEY; ATTORNEY TO BE NOTICED  
Brooks Kushman  
1000 Town Center 22nd Floor  
Southfield , MI 48075  
USA  
248-358-4400  
Email: Tcunningham@brookskushman.Com

J. Michael Huget  
LEAD ATTORNEY; ATTORNEY TO BE NOTICED  
Honigman Miller Schwartz and Cohn LLP  
130 South First Street 4th Floor  
Ann Arbor , MI 48104-1386  
USA  
734-418-4254  
Fax: 734-418-4255  
Email: Mhuget@honigman.Com

James W. Stuart  
LEAD ATTORNEY  
[Term: 03/10/2004]  
Ogne, Alberts,  
1869 E. Maple Road Suite 100  
Troy , MI 48083  
USA  
248-362-3707  
Fax: 248-382-0422  
Email: Jstuart@oaspc.Com

Laurie J. Michelson  
LEAD ATTORNEY; ATTORNEY TO BE NOTICED  
Butzel Long  
150 W. Jefferson Suite 100  
Detroit , MI 48226-4430  
USA  
313-225-7000  
Email: Orłowski@butzel.Com

Marshall J. Schmitt  
LEAD ATTORNEY; ATTORNEY TO BE NOTICED  
Jenner and Block  
330 N. Wabash Avenue  
One Ibm Plaza  
Chicago , IL 60611  
USA  
312-923-2759

Philip J. Kessler  
LEAD ATTORNEY; ATTORNEY TO BE NOTICED  
Thompson & Knight LLP  
2000 Town Center, Suite 1900  
Southfield , MI 48075  
USA  
248-233-0852  
Fax: 214-999-1576  
Email: Philip.Kessler@tklaw.Com

Stanley A. Schlitter  
LEAD ATTORNEY; ATTORNEY TO BE NOTICED  
One IBM Plaza

Maytag Corporation  
Defendant

Suite 4700  
Chicago , IL 60611-7603  
USA  
312-222-9350

J. Michael Huget  
LEAD ATTORNEY; ATTORNEY TO BE NOTICED  
Honigman Miller Schwartz and Cohn LLP  
130 South First Street 4th Floor  
Ann Arbor , MI 48104-1386  
USA  
734-418-4254  
Fax: 734-418-4255  
Email: Mhuget@honigman.Com

James W. Stuart  
LEAD ATTORNEY  
[Term: 03/10/2004]  
Ogne, Alberts,  
1869 E. Maple Road Suite 100  
Troy , MI 48083  
USA  
248-362-3707  
Fax: 248-382-0422  
Email: Jstuart@oaspc.Com

Laurie J. Michelson  
LEAD ATTORNEY; ATTORNEY TO BE NOTICED  
Butzel Long  
150 W. Jefferson Suite 100  
Detroit , MI 48226-4430  
USA  
313-225-7000  
Email: Orłowski@butzel.Com

Marshall J. Schmitt  
LEAD ATTORNEY; ATTORNEY TO BE NOTICED  
Jenner and Block  
330 N. Wabash Avenue  
One Ibm Plaza  
Chicago , IL 60611  
USA  
312-923-2759

Philip J. Kessler  
LEAD ATTORNEY; ATTORNEY TO BE NOTICED  
Thompson & Knight LLP  
2000 Town Center, Suite 1900  
Southfield , MI 48075  
USA  
248-233-0852  
Fax: 214-999-1576  
Email: Philip.Kessler@tklaw.Com

Stanley A. Schlitter  
LEAD ATTORNEY; ATTORNEY TO BE NOTICED  
One IBM Plaza  
Suite 4700  
Chicago , IL 60611-7603  
USA

Touchsensor Technologies, L. L. C.  
Defendant

312-222-9350

J. Michael Huget  
LEAD ATTORNEY; ATTORNEY TO BE NOTICED  
Honigman Miller Schwartz and Cohn LLP  
130 South First Street 4th Floor  
Ann Arbor , MI 48104-1386  
USA  
734-418-4254  
Fax: 734-418-4255  
Email: Mhuget@honigman.Com

James W. Stuart  
LEAD ATTORNEY  
[Term: 03/10/2004]  
Ogne, Alberts,  
1869 E. Maple Road Suite 100  
Troy , MI 48083  
USA  
248-362-3707  
Fax: 248-382-0422  
Email: Jstuart@oaspc.Com

Laurie J. Michelson  
LEAD ATTORNEY; ATTORNEY TO BE NOTICED  
Butzel Long  
150 W. Jefferson Suite 100  
Detroit , MI 48226-4430  
USA  
313-225-7000  
Email: Orłowski@butzel.Com

Marshall J. Schmitt  
LEAD ATTORNEY; ATTORNEY TO BE NOTICED  
Jenner and Block  
330 N. Wabash Avenue  
One Ibm Plaza  
Chicago , IL 60611  
USA  
312-923-2759

Philip J. Kessler  
LEAD ATTORNEY; ATTORNEY TO BE NOTICED  
Thompson & Knight LLP  
2000 Town Center, Suite 1900  
Southfield , MI 48075  
USA  
248-233-0852  
Fax: 214-999-1576  
Email: Philip.Kessler@tklaw.Com

Stanley A. Schlitter  
LEAD ATTORNEY; ATTORNEY TO BE NOTICED  
One IBM Plaza  
Suite 4700  
Chicago , IL 60611-7603  
USA  
312-222-9350

Touchsensor Technologies, L. L. C.  
Counter Claimant

J. Michael Huget  
LEAD ATTORNEY; ATTORNEY TO BE NOTICED  
Honigman Miller Schwartz and Cohn LLP  
130 South First Street 4th Floor  
Ann Arbor , MI 48104-1386  
USA  
734-418-4254  
Fax: 734-418-4255  
Email: Mhuget@honigman.Com

Laurie J. Michelson  
LEAD ATTORNEY; ATTORNEY TO BE NOTICED  
Butzel Long  
150 W. Jefferson Suite 100  
Detroit , MI 48226-4430  
USA  
313-225-7000  
Email: Orlofski@butzel.Com

Marshall J. Schmitt  
LEAD ATTORNEY; ATTORNEY TO BE NOTICED  
Jenner and Block  
330 N. Wabash Avenue  
One Ibm Plaza  
Chicago , IL 60611  
USA  
312-923-2759

Philip J. Kessler  
LEAD ATTORNEY; ATTORNEY TO BE NOTICED  
Thompson & Knight LLP  
2000 Town Center, Suite 1900  
Southfield , MI 48075  
USA  
248-233-0852  
Fax: 214-999-1576  
Email: Philip.Kessler@tklaw.Com

Stanley A. Schlitter  
LEAD ATTORNEY; ATTORNEY TO BE NOTICED  
One IBM Plaza  
Suite 4700  
Chicago , IL 60611-7603  
USA  
312-222-9350

Nartron Corporation  
Counter Defendant

Sangeeta G. Shah  
ATTORNEY TO BE NOTICED  
Brooks Kushman  
1000 Town Center 22nd Floor  
Southfield , MI 48075  
USA  
248-358-4400  
Email: Sshah@brookskushman.Com

Maytag Corporation  
Counter Claimant

J. Michael Huget  
LEAD ATTORNEY; ATTORNEY TO BE NOTICED  
Honigman Miller Schwartz and Cohn LLP  
130 South First Street 4th Floor

Ann Arbor , MI 48104-1386  
USA  
734-418-4254  
Fax: 734-418-4255  
Email: Mhuget@honigman.Com

Laurie J. Michelson  
LEAD ATTORNEY; ATTORNEY TO BE NOTICED  
Butzel Long  
150 W. Jefferson Suite 100  
Detroit , MI 48226-4430  
USA  
313-225-7000  
Email: Orłowski@butzel.Com

Marshall J. Schmitt  
LEAD ATTORNEY; ATTORNEY TO BE NOTICED  
Jenner and Block  
330 N. Wabash Avenue  
One Ibm Plaza  
Chicago , IL 60611  
USA  
312-923-2759

Philip J. Kessler  
LEAD ATTORNEY; ATTORNEY TO BE NOTICED  
Thompson & Knight LLP  
2000 Town Center, Suite 1900  
Southfield , MI 48075  
USA  
248-233-0852  
Fax: 214-999-1576  
Email: Philip.Kessler@tklaw.Com

Stanley A. Schlitter  
LEAD ATTORNEY; ATTORNEY TO BE NOTICED  
One IBM Plaza  
Suite 4700  
Chicago , IL 60611-7603  
USA  
312-222-9350

Nartron Corporation  
Counter Defendant

Sangeeta G. Shah  
ATTORNEY TO BE NOTICED  
Brooks Kushman  
1000 Town Center 22nd Floor  
Southfield , MI 48075  
USA  
248-358-4400  
Email: Sshah@brookskushman.Com

General Electric  
Counter Claimant

J. Michael Huget  
LEAD ATTORNEY; ATTORNEY TO BE NOTICED  
Honigman Miller Schwartz and Cohn LLP  
130 South First Street 4th Floor  
Ann Arbor , MI 48104-1386  
USA  
734-418-4254  
Fax: 734-418-4255

Email: Mhuget@honigman.Com

Laurie J. Michelson  
LEAD ATTORNEY; ATTORNEY TO BE NOTICED  
Butzel Long  
150 W. Jefferson Suite 100  
Detroit , MI 48226-4430  
USA  
313-225-7000  
Email: Orłowski@butzel.Com

Marshall J. Schmitt  
LEAD ATTORNEY; ATTORNEY TO BE NOTICED  
Jenner and Block  
330 N. Wabash Avenue  
One Ibm Plaza  
Chicago , IL 60611  
USA  
312-923-2759

Philip J. Kessler  
LEAD ATTORNEY; ATTORNEY TO BE NOTICED  
Thompson & Knight LLP  
2000 Town Center, Suite 1900  
Southfield , MI 48075  
USA  
248-233-0852  
Fax: 214-999-1576  
Email: Philip.Kessler@tklaw.Com

Stanley A. Schlitter  
LEAD ATTORNEY; ATTORNEY TO BE NOTICED  
One IBM Plaza  
Suite 4700  
Chicago , IL 60611-7603  
USA  
312-222-9350

Nartron Corporation  
Counter Defendant

Sangeeta G. Shah  
ATTORNEY TO BE NOTICED  
Brooks Kushman  
1000 Town Center 22nd Floor  
Southfield , MI 48075  
USA  
248-358-4400  
Email: Sshah@brookskushman.Com

Date	#	Proceeding Text	Source
12/24/2003	1	COMPLAINT for patent infringement and jury demand - Receipt # 36294 - Date Fee Received: 12/24/03 with attachments A-C (DT) (Entered: 12/29/2003)	
12/24/2003		REPORT sent to Washington (DT) (Entered: 12/29/2003)	
12/24/2003	2	STATEMENT of disclosure of corporate affiliations and financial interests by plaintiff Nartron Corp (DT) (Entered: 12/29/2003)	
01/08/2004	3	AMENDED complaint by plaintiff Nartron Corp for patent infringement, with jury, exhibits A-C and proof of service. demand (RH) (Entered: 01/09/2004)	



- 01/14/2004 4 SUMMONS Returned Executed. General Electric served on 1/12/2004, answer due 2/2/2004 (NHoll, ) (Entered: 02/03/2004)
- 01/30/2004 7 SUMMONS Returned Executed. Touchsensor Technologies, L. L. C. served on 1/15/2004, answer due 2/4/2004 (NHoll, ) (Entered: 02/11/2004)
- 02/02/2004 5 ATTORNEY APPEARANCE: James W. Stuart appearing on behalf of General Electric, Maytag Corporation. (NHoll, ) (Entered: 02/11/2004)
- 02/02/2004 6 SUMMONS Returned Executed. Maytag Corporation served on 1/16/2004, answer due 2/5/2004. (NHoll, ) (Entered: 02/11/2004)
- 02/04/2004 8 ATTORNEY APPEARANCE: James W. Stuart appearing on behalf of Touchsensor Technologies, L. L. C. (NHoll, ) (Entered: 02/12/2004)
- 02/11/2004 9 ANSWER to Amended Complaint with Affirmative Defenses, COUNTERCLAIM filed by Touchsensor Technologies, L. L. C. against Nartron Corporation (NHoll, ) (Entered: 02/17/2004)
- 02/11/2004 10 ANSWER to Amended Complaint with Affirmative Defenses, COUNTERCLAIM filed by Maytag Corporation against Nartron Corporation (NHoll, ) (Entered: 02/17/2004)
- 02/11/2004 11 ANSWER to Amended Complaint with Affirmative Defenses, COUNTERCLAIM filed by General Electric against Nartron Corporation (NHoll, ) (Entered: 02/17/2004)
- 02/18/2004 12 ANSWER to 9 Counterclaim by Nartron Corporation. (NHoll, ) Modified on 2/23/2004 (NHoll, ). (Entered: 02/23/2004)
- 02/18/2004 13 ANSWER to 11 Counterclaim by Nartron Corporation. (NHoll, ) (Entered: 02/23/2004)
- 02/18/2004 14 ANSWER to 10 Counterclaim by Nartron Corporation.(NHoll, ) (Entered: 02/24/2004)
- 03/03/2004 16 STATEMENT of DISCLOSURE of CORPORATE AFFILIATIONS and FINANCIAL INTEREST by General Electric (DTyle, ) (Entered: 03/16/2004)
- 03/03/2004 17 STATEMENT of DISCLOSURE of CORPORATE AFFILIATIONS and FINANCIAL INTEREST by Maytag Corporation (DTyle, ) (Entered: 03/16/2004)
- 03/03/2004 18 STATEMENT of DISCLOSURE of CORPORATE AFFILIATIONS and FINANCIAL INTEREST by Touchsensor Technologies, L. L. C. (DTyle, ) (Entered: 03/16/2004)
- 03/04/2004 15 NOTICE TO APPEAR: Scheduling Conference set for 4/1/2004 02:00 PM before Honorable Nancy G Edmunds. (CHem, ) (Entered: 03/04/2004)
- 03/10/2004 19 STIPULATED ORDER substituting attorneys Philip J. Kessler, J. Michael Huget and Laurie J. Michelson for Maytag Corporation, Touchsensor Technologies, L. L. C. and General Electric in place of attorney James W. Stuart Signed by Judge Nancy G Edmunds. (DTyle, ) (Entered: 03/23/2004)
- 03/30/2004 21 DISCOVERY plan jointly filed pursuant to Federal Rules of Civil Procedure 26(f) (NHoll, ) (Entered: 04/14/2004)
- 03/31/2004 22 REVISED DISCOVERY plan jointly filed pursuant to Federal Rules of Civil Procedure 26(f) (NHoll, ) (Entered: 04/14/2004)
- 04/06/2004 Minute Entry -Scheduling Conference held on 4/6/2004 before Honorable Nancy G Edmunds. Status Conference set for 7/13/2004 02:00 PM before Honorable Nancy G Edmunds. (CHem, ) (Entered: 04/07/2004)
- 04/06/2004 27 SCHEDULING ORDER: Status Conference set for 7/13/2004 02:00 PM before Honorable Nancy G Edmunds. Signed by Honorable Nancy G Edmunds. (Refer to image for additional dates)(CHem, ) (Entered: 06/10/2004)
- 04/08/2004 23 STIPULATED PROTECTIVE ORDER Signed by Judge Nancy G Edmunds. (DTyle, ) (Entered: 04/22/2004)

- 05/04/2004 24 NOTICE of Appearance by Marshall J. Schmitt, Stanley A. Schlitter on behalf of General Electric, Maytag Corporation, Touchsensor Technologies, L. L. C. (DTyle, ) (Entered: 05/06/2004)
- 06/07/2004 (STICKEN 6/10/04) Ex Parte MOTION to Amend/Correct 20 Scheduling Conference, Set Scheduling Order Deadlines by Nartron Corporation. (Attachments: # 1 Index of Exhibits # 2 Exhibit 6/4/04 letter regarding mediation# 3 Exhibit 6/4/04 letter regarding document production)(Shah, Sangeeta) Modified on 6/10/2004 (CHem, ). (Entered: 06/07/2004)
- 06/10/2004 26 ORDER to Strike 25 Ex Parte MOTION to Amend/Correct 20 Scheduling Conference, Set Scheduling Order Deadlines filed by Nartron Corporation. Signed by Honorable Nancy G Edmunds. (CHem, ) (Entered: 06/10/2004)
- 06/14/2004 28 MOTION to Amend/Correct 27 Scheduling Order by Nartron Corporation. (Attachments: # 1 Index of Exhibits # 2 Exhibit 6/4/04 letter regarding mediator# 3 Exhibit 6/4/04 letter regarding document production)(Shah, Sangeeta) (Entered: 06/14/2004)
- 06/24/2004 29 RESPONSE to 28 Motion to amend scheduling order filed by General Electric, Maytag Corporation and Touchsensor Technologies, L. L. C.; with exhibit A. (DPer, ) (Entered: 06/30/2004)
- 07/01/2004 30 REPLY to Response re 28 MOTION to Amend/Correct 27 Scheduling Order filed by Nartron Corporation. (Shah, Sangeeta) (Entered: 07/01/2004)
- 07/13/2004 Minute Entry -Status Conference held on 7/13/2004, parties agreed to special master, before Honorable Nancy G Edmunds. (CHem, ) (Entered: 07/21/2004)
- 07/27/2004 31 DECLARATION of compliance by John Robinson Thomas (DTyle, ) (Entered: 08/02/2004)
- 07/27/2004 32 AFFIDAVIT of John R. Thomas (DTyle, ) (Entered: 08/02/2004)
- 07/29/2004 33 AMENDED SCHEDULING ORDER: Signed by Honorable Nancy G Edmunds. (Refer to image for dates)(DTyle, ) (Entered: 08/05/2004)
- 07/29/2004 34 APPOINTMENT AND ORDER of reference to Special Master Signed by Honorable Nancy G Edmunds. (DTyle, ) (Entered: 08/05/2004)
- 08/13/2004 35 MOTION to Amend the scheduling order and MOTION to Compel Discovery by Nartron Corporation. (Attachments: # 1 Document Continuation # 2 Document Continuation # 3 Document Continuation # 4 Document Continuation)(DTyle, ) (Entered: 08/16/2004)
- 08/19/2004 36 RESPONSE to 35 Motion to Amend scheduling order and Motion to Compel discovery filed by defendants. (DTyle, ) (Entered: 08/23/2004)
- 08/31/2004 37 ORDER REFERRING MOTION to Magistrate Judge Komives: 35 MOTION to Amend/Correct MOTION to Compel filed by Nartron Corporation. Signed by Honorable Nancy G Edmunds. (CHem, ) (Entered: 08/31/2004)
- 08/31/2004 39 REPLY to Response re 35 MOTION to Amend Scheduling Order and MOTION to Compel filed by Nartron Corporation. (CMul, ) (Entered: 09/02/2004)
- 09/02/2004 38 NOTICE of hearing on 35 MOTION to Amend/Correct MOTION to Compel. Motion Hearing set for 9/15/2004 11:00 AM before Honorable Paul J Komives. (SJef, ) (Entered: 09/02/2004)
- 09/16/2004 Minute Entry -Motion Hearing held on 9/16/2004 re 35 MOTION to Amend/Correct MOTION to Compel filed by Nartron Corporation before Honorable Paul J Komives. Disposition: TAKEN UNDER ADVISEMENT (Tape # 04-010) (SJef, ) (Entered: 09/16/2004)
- 09/23/2004 40 ORDER of DISQUALIFICATION and REASSIGNING CASE from Magistrate Judge Paul J Komives to Magistrate Judge Virginia M Morgan Signed by Honorable Paul J Komives. (SSchoe, ) (Entered: 09/24/2004)
- 09/27/2004 41 TRANSCRIPT of Proceedings held on 9/15/04 of plaintiff's motion to amend

- scheduling order and motion to compel discovery (DTyle, ) (Entered: 09/28/2004)
- 09/29/2004 42 ORDER Referring Pretrial Matters to Magistrate Judge Virginia M Morgan. Signed by Honorable Nancy G Edmunds. (CHem, ) (Entered: 09/29/2004)
- 10/08/2004 43 AMENDED DISCOVERY plan jointly filed pursuant to Federal Rules of Civil Procedure 26(f); with exhibit A. (Attachments: # 1 Document Continuation)(DPer, ) (Entered: 10/13/2004)
- 10/27/2004 44 NOTICE of hearing on 35 MOTION to Amend/Correct MOTION to Compel. Resolved/Unresolved Issues due by 11/8/2004. Motion Hearing set for 11/15/2004 10:30 AM before Honorable Virginia M Morgan. (JOwe, ) (Entered: 10/27/2004)
- 10/29/2004 45 STATEMENT of Claim Construction Statement by Nartron Corporation. (Attachments: # 1 Index of Exhibits # 2 Exhibit A - Table with Parties' Proposed Constructions)(Shah, Sangeeta) (Entered: 10/29/2004)
- 10/29/2004 46 STATEMENT regarding claim construction by General Electric, Maytag Corporation, Touchsensor Technologies, L. L. C.. (Attachments: # 1 Document Continuation # 2 Document Continuation)(DTyle, ) (Entered: 11/01/2004)
- 11/15/2004 Minute Entry -Motion Hearing not held on 11/15/2004 re 35 MOTION to Amend/Correct MOTION to Compel filed by Nartron Corporation before Honorable Virginia M Morgan. Disposition: WITHDRAWN; CASE SETTLED (JOwe, ) (Entered: 11/15/2004)
- 11/15/2004 47 ORDER withdrawing 35 Motion to Amend/Correct, withdrawing 35 Motion to Compel- Signed by Honorable Virginia M Morgan. (JOwe, ) (Entered: 11/16/2004)
- 11/30/2004 48 STIPULATED ORDER STAYING CASE. Signed by Honorable Nancy G Edmunds. (LBeh, ) (Entered: 12/07/2004)
- 02/14/2005 49 STIPULATED ORDER DISMISSING CASE with prejudice Signed by Honorable Nancy G Edmunds. (DTyle, ) (Entered: 02/15/2005)

---

Copyright © 2014 LexisNexis CourtLink, Inc. All rights reserved.  
\*\*\* THIS DATA IS FOR INFORMATIONAL PURPOSES ONLY \*\*\*

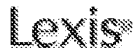

Switch Client | Preferences | Help | Sign Out

My Lexis™ Search Get a Document Shepard's® More History Alerts

All Add/Edit Subtabs

Command Searching > Utility, Design and Plant Patents

**Search** View Tutorial | Help

Select Search Type and Enter Search Terms

<b>Terms &amp; Connectors</b> <input type="checkbox"/> Natural Language <input type="checkbox"/> Easy Search™ <input type="checkbox"/> Semantic Search <input type="checkbox"/> What's this?	<input type="text" value="patno=5796183"/>	<input type="button" value="Search"/>
--	--	---------------------------------------

Suggest terms for my search

Check spelling

**Restrict by Document Segment**

Select a document segment, enter search terms for the segment, then click Add.

Select a Segment

**Note:** Segment availability differs between sources. Segments may not be applied consistently across sources.

**Restrict by Date**

No Date Restrictions  From  To  Date formats...

<b>Search Connectors</b> and     and     w/p     in same paragraph or     or     w/seg     in same segment w/N     within N words     w/s     in same sentence pre/N     precedes by N words     and not     and not More Connectors & Commands...	<b>How Do I...?</b> Combine sources? Restrict by date? Restrict by document segment? Use wildcards as placeholders for one or more characters in a search term? View Tutorials
---	---

*5,796,183 Apr. 29, 2013 Hourmand, et. al.*

**5,796,183**

EX PARTE REEXAMINATION CERTIFICATE C1 (9614th)

Apr. 29, 2013

Capacitive Responsive Electronic Switching Circuit

**CORE TERMS:** touch, terminal, oscillator, input, output signal, detector, responsive, second touch, electronic switching, capacitive ...

Source: [Command Searching > Utility, Design and Plant Patents](#) 

Terms: **patno=5796183** (Suggest Terms for My Search)

View: KWIC

Date/Time: Sunday, January 26, 2014 - 3:57 PM EST



**LexisNexis**

[About LexisNexis](#) | [Privacy Policy](#) | [Terms & Conditions](#) | [Contact Us](#)

Copyright © 2014 LexisNexis, a division of Reed Elsevier Inc. All rights reserved.



Switch Client | Preferences | Help | Sign Out

My Lexis™ Search Get a Document Shepard's® More History Alerts

All Add/Edit Subtabs

Command Searching > Patent Cases from Federal Courts and Administrative Materials

**Search** View Tutorial | Help

Select Search Type and Enter Search Terms

Terms & Connectors	5796183 or 5,796,183	Suggest terms for my search	<input type="button" value="Search"/>
Natural Language			
Easy Search™			

Check spelling

**Restrict by Document Segment**

Select a document segment, enter search terms for the segment, then click Add.

Select a Segment

**Note:** Segment availability differs between sources. Segments may not be applied consistently across sources.

**Restrict by Date**

No Date Restrictions  From  To  Date formats...

<p><b>Search Connectors</b></p> <p>and and w/p in same paragraph</p> <p>or or w/seg in same segment</p> <p>w/N within N words w/s in same sentence</p> <p>pre/N precedes by N words and not and not</p> <p>More Connectors &amp; Commands...</p>	<p><b>How Do I...?</b></p> <p>Combine sources?</p> <p>Restrict by date?</p> <p>Restrict by document segment?</p> <p>Use wildcards as placeholders for one or more characters in a search term?</p> <p>View Tutorials</p>
--	--



Switch Client | Preferences | Help | Sign Out

<a href="#">My Lexis™</a>	<a href="#">Search</a>	<a href="#">Get a Document</a>	<a href="#">Shepard's®</a>	<a href="#">More</a>	<a href="#">History</a>
					<a href="#">Alerts</a>

FOCUS™ Terms:  Search Within:  [View Tutorial](#)  
 Advanced...

Source: [Command Searching > Patent Cases from Federal Courts and Administrative Materials](#)

Terms: **5796183 or 5,796,183** (Suggest Terms for My Search)

Select for FOCUS™ or Delivery

- 1. QRG, Ltd. v. Nartron Corp., CIVIL NO. 1:06-CV-1777, UNITED STATES DISTRICT COURT FOR THE MIDDLE DISTRICT OF PENNSYLVANIA, 2007 U.S. Dist. LEXIS 55848, August 1, 2007, Decided, August 1, 2007, Filed

**CORE TERMS:** patent, infringement, declaratory judgment, subject matter jurisdiction, counterclaim, product lines, discovery, status report, identification, apprehension ...

... lines do not infringe U.S. patents: 4,731,548; 4,758,735; 4,831,279; 5,087,825; **5,796,183** ("patents"). Nartron asserts a counterclaim that some of QRG's QProx

... products, and Nartron's patents -- U.S. patents: 4,731,548; 4,758,735; 4,831,279; 5,087,825; **5,796,183**. All other claims are DISMISSED for lack of subject matter ...

- 2. QRG, Ltd. v. Nartron Corp., CIVIL NO. 1:06-CV-1777 , UNITED STATES DISTRICT COURT FOR THE MIDDLE DISTRICT OF PENNSYLVANIA, 2007 U.S. Dist. LEXIS 29725, April 23, 2007, Decided , April 23, 2007, Filed , Claim dismissed by QRG, Ltd. v. Nartron Corp., 2007 U.S. Dist. LEXIS 55848 (M.D. Pa., Aug. 1, 2007)

**CORE TERMS:** counterclaim, discovery, amend, declaratory judgment, inexcusable delay, infringement, bad faith, futility, patent, product lines ...

... not violate Nartron's patents (U.S. patents: 4,731,548; 4,758,735; 4,831,279; 5,087,825; **5,796,183** ("patents")). Nartron has filed an answer to QRG's amended declaratory ...



- 3. QRG, Ltd. v. Nartron Corp., CIVIL NO. 1:06-CV-1777 , UNITED STATES DISTRICT COURT FOR THE MIDDLE DISTRICT OF PENNSYLVANIA, 513 F. Supp. 2d 149; 2007 U.S. Dist. LEXIS 14782, March 2, 2007, Decided , March 2, 2007, Filed , Motion to strike denied by QRG, Ltd. v. Nartron Corp., 2007 U.S. Dist. LEXIS 29725 (M.D. Pa., Apr. 23, 2007)

**OVERVIEW:** Court reserved ruling on the holder's motion to dismiss in part, because the competitor's attempt to identify other allegedly infringing products was insufficient to satisfy the second prong of the patent infringement declaratory judgment test; namely, it was unclear what products and components the competitor was referring.

**CORE TERMS:** patent, apprehension, infringement, declaratory judgment, patent

infringement, prong, patentee's, matter jurisdiction, actual controversy, caption ...



... not violate Nartron's patents (U.S. patents: 4,731,548; 4,758,735; 4,831,279; 5,087,825; **5,796,183** ("patents")). Nartron has filed this motion to dismiss pursuant to Federal Rule of Civil Procedure 12(b)(1) ...

-   4. Nartron Corp. v. Quantum Research Group, Ltd., Case Number 06-13792 , UNITED STATES DISTRICT COURT FOR THE EASTERN DISTRICT OF MICHIGAN, SOUTHERN DIVISION, 473 F. Supp. 2d 790; 2007 U.S. Dist. LEXIS 12373, February 12, 2007, Decided , Related proceeding at QRG, Ltd. v. Nartron Corp., 2007 U.S. Dist. LEXIS 14782 (M.D. Pa., Mar. 2, 2007)

**OVERVIEW:** Company's motion to dismiss was granted because a prior lawsuit in Pennsylvania involving the same claims between the same parties was filed in a federal court of equal rank and the matter should proceed there. Moreover, the court did not have personal jurisdiction over the company on the basis of Fed. R. Civ. P. 4(k)(2).

**CORE TERMS:** patent, personal jurisdiction, entity, infringement, website, qprox, declaratory, technology, lawsuit, replies ...

... reads as follows: Re: US patents 4,731,548; 4,758,735; 4,831,279; 5,087,825; **5,796,183** Dear Mr. Phillip: We have recently been made aware of ...

-   5. QRG, Ltd. v. Nartron Corp., Civil Action No. 06-500 , UNITED STATES DISTRICT COURT FOR THE WESTERN DISTRICT OF PENNSYLVANIA, 2006 U.S. Dist. LEXIS 64121, September 7, 2006, Decided , September 7, 2006, Filed , Related proceeding at Nartron Corp. v. Quantum Research Group, Ltd., 2007 U.S. Dist. LEXIS 12373 ( E.D. Mich., Feb. 12, 2007)

**OVERVIEW:** The fact that Michigan patent holder weekly shipped goods to Pennsylvania rendered it subject to general personal jurisdiction in Pennsylvania. Court sua sponte exercised its discretion under 28 U.S.C.S. § 1406(a) and transferred patent declaratory judgment suit to Middle District of Pennsylvania, which was proper venue under 28 U.S.C.S. § 1391(c).

**CORE TERMS:** personal jurisdiction, continuous, systematic, venue, general jurisdiction, judicial district, reside, asserting, patents, sua sponte ...

... Patent Nos. 4,731,548 ("the '548 Patent"), 4,758,735 ("the '735 Patent"), **5,796,183** ("The '183 Patent"), 4,831,279 ("the '279 Patent"), and 5,087,825 ("the '825 Patent" ...





Source: **Command Searching > Patent Cases from Federal Courts and Administrative Materials** 

Terms: **5796183 or 5,796,183** (Suggest Terms for My Search)



View: Cite

Date/Time: Sunday, January 26, 2014 - 3:58 PM EST

\* Signal Legend:

-  - Warning: Negative treatment is indicated
-  - Questioned: Validity questioned by citing refs
-  - Caution: Possible negative treatment
-  - Positive treatment is indicated



-  - Citing Refs. With Analysis Available
  -  - Citation information available
- \* Click on any *Shepard's* signal to *Shepardize®* that case.



[About LexisNexis](#) | [Privacy Policy](#) | [Terms & Conditions](#) | [Contact Us](#)  
Copyright © 2014 LexisNexis, a division of Reed Elsevier Inc. All rights reserved.



Switch Client | Preferences | Help | Sign Out

My Lexis™ Search Get a Document Shepard's® More History Alerts

All Add/Edit Subtabs

Command Searching > Patent, Trademark & Copyright Periodicals, Combined

**Search** View Tutorial | Help

Select Search Type and Enter Search Terms

Terms & Connectors	5796183 or 5,796,183	Suggest terms for my search  Check spelling
Natural Language		
Easy Search™		

**Restrict by Document Segment**

Select a document segment, enter search terms for the segment, then click Add.

Select a Segment

Note: Segment availability differs between sources. Segments may not be applied consistently across sources.

**Restrict by Date**

No Date Restrictions  From  To  [Date formats...](#)

<p><b>Search Connectors</b></p> <p>and     and                     w/p     in same paragraph</p> <p>or       or                            w/seg   in same segment</p> <p>w/N     within N words            w/s     in same sentence</p> <p>pre/N   precedes by N words   and not   and not</p> <p><a href="#">More Connectors &amp; Commands...</a></p>	<p><b>How Do I...?</b></p> <p><a href="#">Combine sources?</a></p> <p><a href="#">Restrict by date?</a></p> <p><a href="#">Restrict by document segment?</a></p> <p><a href="#">Use wildcards as placeholders for one or more characters in a search term?</a></p> <p><a href="#">View Tutorials</a></p>
--	--

**No Documents Found**

No documents were found for your search terms  
"5796183 or 5,796,183"

Click "Save this search as an Alert" to schedule your search to run in the future.

- OR -

Click "Search Using Natural Language" to run your search as Natural Language search.

- OR -

Click "Edit Search" to return to the search form and modify your search.

Suggestions:

- Check for spelling errors.
- Remove some search terms.
- Use more common search terms, such as those listed in "Suggested Words and Concepts."
- Use a less restrictive date range.
- Use "OR" in between terms to search for one term or the other.

**Save this Search as an Alert** ||| **Search Using Natural Language** ||| **Edit Search** |||



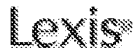

Switch Client | Preferences | Help | Sign Out

My Lexis™ Search  Get a Document Shepard's® More History Alerts

All

Command Searching > All English Language News

View Tutorial | Help

**Search**

Select Search Type and Enter Search Terms

Terms & Connectors	5796183 or 5,796,183	<input type="button" value="Suggest terms for my search"/>  <input type="button" value="Check spelling"/>	<input type="button" value="Search"/>
Natural Language			
Easy Search™			

**Restrict by Document Segment**

Select a document segment, enter search terms for the segment, then click Add.

Select a Segment

Note: Segment availability differs between sources. Segments may not be applied consistently across sources.

**Restrict by Date**

No Date Restrictions  From  To

<p><b>Search Connectors</b></p> <p>and    and                    w/p    in same paragraph</p> <p>or     or                         w/seg  in same segment</p> <p>w/N    within N words         w/s    in same sentence</p> <p>pre/N  precedes by N words   and not  and not</p> <p><a href="#">More Connectors &amp; Commands...</a></p>	<p><b>How Do I...?</b></p> <p><a href="#">Combine sources?</a></p> <p><a href="#">Restrict by date?</a></p> <p><a href="#">Restrict by document segment?</a></p> <p><a href="#">Use wildcards as placeholders for one or more characters in a search term?</a></p> <p><a href="#">View Tutorials</a></p>
--	--



Switch Client | Preferences | Help | Sign Out

<a href="#">My Lexis™</a>	<a href="#">Search</a>	<a href="#">Get a Document</a>	<a href="#">Shepard's®</a>	<a href="#">More</a>	<a href="#">History</a>
					<a href="#">Alerts</a>

FOCUS™ Terms  Search Within   [Advanced...](#)  
[View Tutorial](#)

Source: [Command Searching > All English Language News](#)

Terms: **5796183 or 5,796,183** ([Suggest Terms for My Search](#))

*Cumberland Pharmaceuticals Reports 58% Increase in Net Revenue With Third Quarter 2009 Financial Results; - Caldolor(R) begins generating revenue; - 20% increase in revenue for Acetadote(R) and Kristalose(R); - Profitability maintained through Caldolor(R) launch PR Newswire November 10, 2009 Tuesday 7:30 AM EST*

Copyright 2009 PR Newswire Association LLC  
 All Rights Reserved  
 PR Newswire

November 10, 2009 Tuesday 7:30 AM EST

**LENGTH:** 5124 words

**HEADLINE:** Cumberland Pharmaceuticals Reports 58% Increase in Net Revenue With Third Quarter 2009 Financial Results;  
 - Caldolor(R) begins generating revenue;  
 - 20% increase in revenue for Acetadote(R) and Kristalose(R);  
 - Profitability maintained through Caldolor(R) launch

**DATELINE:** NASHVILLE, Tenn., Nov. 10

**BODY:**

NASHVILLE, Tenn., Nov. 10 /PRNewswire-FirstCall/ -- Cumberland Pharmaceuticals Inc. (↖ Nasdaq: CPIX ↗), a specialty pharmaceutical company focused on the hospital acute care and gastroenterology markets, today announced third quarter 2009 financial results.

"With an earlier-than-anticipated Caldolor launch, we were able to dramatically exceed our earnings expectations in the third quarter," said A.J. Kazimi, Chief Executive Officer of Cumberland Pharmaceuticals. "Additionally, the completion of our initial public offering in August provides us with the strongest balance sheet in the history of the Company. We intend to put that capital to good use not only by supporting the Caldolor launch, but also by adding select new products to our portfolio that can benefit patients and enhance shareholder value."

Net Revenue: For the three months ended September 30, 2009, net revenue was \$13.6 million, up 58% from the corresponding period in 2008. This growth was attributable to initial revenue from Caldolor (ibuprofen) Injection, the Company's recently approved IV treatment for pain and fever, as well as an increase in volume for Acetadote (acetylcysteine) Injection, Cumberland's treatment for acetaminophen overdose. Net revenue for the nine months ended September 30, 2009, was \$32.8 million, up 30% from \$25.3 million for the same period in 2008, also primarily due to the Caldolor launch and Acetadote sales growth.

**Operating Expenses:** Total operating expenses for the three months ended September 30, 2009, were \$11.2 million, compared to \$6.5 million for the same period in 2008. This increase was due primarily to sales and marketing expense associated with the Caldolor launch, higher cost of products sold resulting from sales growth and a change in product mix, as well as a significant, non-recurring payroll tax expense of \$1.0 million related to the exercise of non-qualified options. For the nine-month period ended September 30, 2009, total operating expenses were \$27.7 million, compared with \$19.5 million for the corresponding period in 2008. This increase primarily reflected Caldolor milestone obligations related to FDA approval, the aforementioned payroll tax expense, costs incurred in connection with the Company's hospital sales force expansion, and increased marketing and advertising costs associated with the Caldolor launch.

**Net Income:** Net income for the three months ended September 30, 2009, grew to \$1.3 million, or \$0.07 per diluted share, compared to \$1.2 million, or \$0.07 per diluted share, for the same period in 2008. Excluding the non-recurring payroll tax expense, net income for the three months ended September 30, 2009, would have increased 54% to \$1.9 million, or \$0.10 per diluted share.

Net income for the nine months ended September 30, 2009, was \$2.8 million, or \$0.16 per diluted share, compared to \$3.7 million, or \$0.22 per diluted share, for the corresponding period in 2008. The decrease is due primarily to milestone obligations triggered by FDA approval of Caldolor in the second quarter of 2009, as well as the aforementioned sales force expansion and option-related payroll tax. Excluding Caldolor milestone payments and the non-recurring payroll tax expense, net income for the nine months ended September 30, 2009, would have grown 25% to \$4.6 million, or \$0.27 per diluted share.

**Cash and Cash Equivalents:** As of September 30, 2009, Cumberland had \$79.5 million in cash and cash equivalents, a \$67.7 million increase from June 30, 2009. The increase was largely due to the Company's initial public offering in August. At quarter's end, Cumberland had total debt of \$19.8 million, including \$4.5 million in current liabilities. The Company had net accounts receivable and inventories of \$7.3 million and \$1.7 million, respectively, at September 30, 2009.

### Third Quarter Highlights

#### Caldolor Launch

In September 2009, Cumberland successfully launched Caldolor in the U.S., and the Company's hospital and field sales forces comprised of 113 experienced sales professionals are now promoting the product. Caldolor is fully stocked at wholesalers serving hospitals nationwide, and is available in both 400 mg and 800 mg vials. The Company is working to introduce Caldolor and secure formulary approval nationally. The product is now stocked in a number of medical facilities across the country. In addition to personal sales promotion Cumberland is supporting the product through a multi-faceted campaign, including internet and media advertising, medical society and convention presence, journal publications, and its medical information call center, among other initiatives.

#### Initial Public Offering

In August 2009, Cumberland completed its initial public offering of 5,000,000 shares of common stock at a price to the public of \$17.00 per share, raising \$85.0 million in gross proceeds. Net proceeds to the Company were \$74.8 million after commissions and offering expenses. The proceeds from this offering are being used primarily for potential acquisitions, the launch of Caldolor, expansion of the Company's hospital sales force, product development, debt repayment and general corporate purposes. Cumberland's common stock began trading on the NASDAQ Global Select Market on August 11, 2009, under the trading symbol "CPIX."

#### Recent Events

#### International Markets

In October 2009, the Company announced that it has entered into an exclusive agreement with Phebra Pty Ltd., an Australian-based specialty pharmaceutical company, for the commercialization of Caldolor in Australia and New Zealand. Phebra will be responsible for obtaining any regulatory approval for the product, and for handling ongoing regulatory requirements, product marketing, distribution and sales in the territories. Cumberland will maintain responsibility for product formulation, development and manufacturing, and will provide finished product to Phebra. Under the terms of the agreement, Cumberland will receive upfront and milestone payments as well as a transfer price, and will also receive royalties on any future sales of Caldolor in those territories.

#### New Intellectual Property Initiative for Caldolor

In addition to Cumberland's issued patent for Caldolor, the Company has filed the first of several expected new patent applications for the product. Cumberland's clinical research uncovered several new product-related discoveries, for which the Company filed several provisional patent applications. Part of an ongoing initiative to protect the Company's intellectual property, this new patent application addresses Cumberland's proprietary method of dosing intravenous ibuprofen.

#### Supplemental Financial Information

The following tables provide a reconciliation of Cumberland's reported (GAAP) statements of income to adjusted (non-GAAP) statements of income for the three- and nine-month periods ended September 30, 2009. The adjusted statements exclude certain non-recurring items, and are provided by management to assist investors in evaluating Cumberland's operating results. The adjusted statements should not be considered a substitute for Cumberland's reported statements of income.

Three Months Ended September 30, 2009	As reported	Adjustments	As adjusted
	-----	-----	-----
Net revenues	\$13,597,760		\$13,597,760
Costs and expenses:			
Cost of products sold	1,761,069		1,761,069
Selling and marketing	6,087,807		6,087,807
Research and development	640,877		640,877
General and administrative	2,537,627	(977,258) (1)	1,560,369
Amortization of product license right	171,726		171,726
Other	26,595		26,595
	-----	-----	-----
Total costs and expenses	11,225,701	(977,258)	10,248,443
	-----	-----	-----
Operating income	2,372,059	977,258	3,349,317
Interest income	14,285		14,285
Interest expense	(248,272)		(248,272)
	-----	-----	-----
Net income before income taxes	2,138,072	977,258	3,115,330
Income tax expense	(855,660)	(403,608) (1)	(1,259,268)
	-----	-----	-----
Net income	1,282,412	573,650	1,856,062
Net loss at subsidiary attributable to noncontrolling interests	5,725		5,725
	-----	-----	-----

Net income attributable to common shareholders	\$1,288,137	573,650	\$1,861,787
	=====	=====	=====
Weighted-average shares outstanding - diluted	19,183,606		19,183,606
Earnings per share - diluted	\$0.07		\$0.10

Notes to reconciliation of reported statement of income to adjusted  
statement of income:

- To exclude payroll-related taxes and income tax benefit associated  
with the exercise of non-qualified options in 2009.

Nine Months Ended September 30, 2009

	As reported	Adjustments	As adjusted
	-----	-----	-----
Net revenues	\$32,822,972		\$32,822,972
Costs and expenses:			
Cost of products sold	3,271,363		3,271,363
Selling and marketing	14,611,796		14,611,796
Research and development	4,041,719	(1,950,362) (1)	2,091,357
General and administrative	5,218,925	(1,093,464) (2)	4,125,461
Amortization of product license right	515,178		515,178
Other	80,791		80,791
	-----	-----	-----
Total costs and expenses	27,739,772	(3,043,826)	24,695,946
	-----	-----	-----
Operating income	5,083,200	3,043,826	8,127,026
Interest income	42,041		42,041
Interest expense	(430,207)		(430,207)
	-----	-----	-----
Net income before income taxes	4,695,034	3,043,826	7,738,860
Income tax expense	(1,919,356)	(1,257,100) (3)	(3,176,456)
	-----	-----	-----
Net income	2,775,678	1,786,726	4,562,404
Net loss at subsidiary attributable to noncontrolling interests	26,420		26,420
	-----	-----	-----
Net income attributable to common shareholders	\$2,802,098	1,786,726	\$4,588,824
	=====	=====	=====
Weighted-average shares outstanding - diluted	17,143,348		17,143,348
Earnings per share - diluted	\$0.16		\$0.27

Notes to reconciliation of reported statement of income to adjusted



statement of income:

1. To exclude milestone expenses associated with the FDA approval of Caldolor.
2. To exclude payroll-related taxes associated with the exercise of non-qualified options in 2009.
3. To include the tax impact of adjustments.

#### Conference Call and Webcast

A conference call and live webcast will be held on Tuesday, November 10, 2009, at 10:00 a.m. Eastern Time to discuss the Company's third quarter 2009 financial results. To participate on the call, please dial 888-417-8462 (for U.S. callers) or 719-457-2552 (for international callers). A rebroadcast of the teleconference will be available for one week and can be accessed by dialing 888-203-1112 (for U.S. callers) or 719-457-0820 (for international callers). The passcode for the rebroadcast is 9695498. The live webcast and rebroadcast can be accessed via Cumberland Pharmaceuticals' website at <http://investor.shareholder.com/cpix/events.cfm>.

#### About Cumberland Pharmaceuticals

Cumberland Pharmaceuticals Inc. is a Tennessee-based specialty pharmaceutical company focused on the acquisition, development and commercialization of branded prescription products. The Company's primary target markets include hospital acute care and gastroenterology. Cumberland's product portfolio includes Acetadote® (acetylcysteine) Injection for the treatment of acetaminophen poisoning and Kristalose® (lactulose) for Oral Solution, a prescription laxative. The Company also recently launched Caldolor® (ibuprofen) Injection, the first injectable treatment for pain and fever available in the United States. Cumberland is dedicated to providing innovative products which improve quality of care for patients. The Company completed the initial public offering of its common stock in August 2009. For more information on Cumberland Pharmaceuticals, please visit [www.cumberlandpharma.com](http://www.cumberlandpharma.com).

#### About Caldolor

Caldolor is indicated for the management of mild to moderate pain and management of moderate to severe pain as an adjunct to opioid analgesics, as well as the reduction of fever in adults. It is the first FDA-approved intravenous therapy for fever. Caldolor is contraindicated in patients with known hypersensitivity to ibuprofen or other NSAIDs, patients with asthma, urticaria, or allergic type reactions after taking aspirin or other NSAIDs. Caldolor is contraindicated for use during the peri-operative period in the setting of coronary artery bypass graft (CABG) surgery. Caldolor should be used with caution in patients with prior history of ulcer disease or GI bleeding, in patients with fluid retention or heart failure, in the elderly, those with renal impairment, heart failure, liver impairment, and those taking diuretics or ACE inhibitors. Blood pressure should be monitored during treatment with Caldolor. For full prescribing information, including boxed warning, visit [www.caldolor.com](http://www.caldolor.com).

#### About Acetadote

Acetadote is used in the emergency department to prevent or lessen potential liver damage resulting from an overdose of acetaminophen, a common ingredient in many over-the-counter painkillers. It is the only approved injectable product in the United States for the treatment of acetaminophen overdose, the leading cause of poisonings presenting in emergency departments in the country(1). Acetadote is contraindicated in patients with hypersensitivity or previous anaphylactoid reactions to acetylcysteine or any components of the preparation. Serious anaphylactoid reactions, including death in a patient with asthma, have been reported in patients administered acetylcysteine intravenously. Acetadote should be used with caution in patients with asthma, or where there is a history of bronchospasm. The total volume administered should be

adjusted for patients less than 40 kg and for those requiring fluid restriction. To avoid fluid overload, the volume of diluent should be reduced as needed. If volume is not adjusted, fluid overload can occur, potentially resulting in hyponatremia, seizure, and death. For full prescribing information, visit [www.aceiadote.net](http://www.aceiadote.net).

About Kristalose

Kristalose is indicated for the treatment of acute and chronic constipation. It is a unique, proprietary, crystalline form of lactulose, with no restrictions on length of therapy or patient age. Initial dosing may produce flatulence and intestinal cramps, which are usually transient. Excessive dosage can lead to diarrhea with potential complications such as loss of fluids, hypokalemia and hypernatremia. Nausea and vomiting have been reported. Use with caution in diabetics. Kristalose is contraindicated in patients who require a low-galactose diet. Elderly, debilitated patients who receive lactulose for more than six months should have serum electrolytes (potassium, chloride, carbon dioxide) measured periodically. For full prescribing information, visit [www.kristalose.com](http://www.kristalose.com).

Forward Looking Statements

This press release contains "forward-looking statements", including statements regarding estimated results of operations in future periods. These statements are subject to the finalization of Cumberland's quarterly financial and accounting procedures and reflect Cumberland's current views with respect to future events, based on what it believes are reasonable assumptions. No assurance can be given that these events will occur. As with any business, all phases of Cumberland's operations are subject to influences outside its control. Any one or a combination of these factors could materially affect the results of Cumberland's operations. These factors include, among other things, market conditions, commercialization of Caldolor, competition from existing and new products, which could diminish the commercial potential of Cumberland's products, an inability of manufacturers to produce Cumberland's products on a timely basis or a failure of manufacturers to comply with stringent regulations applicable to pharmaceutical manufacturers, maintaining and building an effective sales and marketing infrastructure, Cumberland's ability to identify and acquire rights to products, government regulation, the possibility that Cumberland's marketing exclusivity and patent rights may provide limited protection from competition, and other factors discussed in the Company's Registration Statement declared effective by the SEC on August 10, 2009. There can be no assurance that the results or developments anticipated by the Company will be realized or, even if substantially realized, that they will have the expected effects on the Company's business and operations. Readers are cautioned not to place undue reliance on these forward-looking statements, which speak only as of the date hereof. The Company does not undertake any obligation to release publicly any revisions to these statements to reflect events or circumstances after the date hereof or to reflect the occurrence of unanticipated events.

(1) National Poison Data System, American Association of Poison Control Centers

SOURCE: Cumberland Pharmaceuticals Inc. ▼

CUMBERLAND PHARMACEUTICALS INC. ▼  
 CONDENSED CONSOLIDATED BALANCE SHEETS  
 (UNAUDITED)

	December 31, 2008 ----	September 30, 2009 ----
ASSETS		
Current assets:		
Cash and cash equivalents	\$11,829,551	\$79,541,274
Accounts receivable, net of allowances	3,129,347	7,282,371

Inventories	1,762,776	1,687,591
Prepaid and other current assets	481,312	2,536,202
Deferred tax assets	507,212	505,617
	-----	-----
Total current assets	17,710,198	91,553,055
Property and equipment, net	432,413	597,238
Intangible assets, net	8,528,732	8,099,612
Deferred tax assets	1,000,031	990,661
Other assets	3,447,813	415,170
	-----	-----
Total assets	\$31,119,187	\$101,655,736
	=====	=====
LIABILITIES AND EQUITY		
Current liabilities:		
Current portion of long-term debt	\$1,250,000	\$4,500,000
Current portion of other long-term obligations	457,915	204,027
Accounts payable	3,257,164	5,797,596
Other accrued liabilities	2,640,855	3,056,915
	-----	-----
Total current liabilities	7,605,934	13,558,538
Revolving line of credit	1,825,951	1,825,951
Long-term debt, excluding current portion	3,750,000	13,500,000
Other long-term obligations, excluding current portion	382,487	180,652
	-----	-----
Total liabilities	13,564,372	29,065,141
	-----	-----
Commitments and contingencies		
Redeemable common stock	-	1,930,000
Shareholders' equity:		
Cumberland Pharmaceuticals Inc. ▼		
shareholders' equity:		
Convertible preferred stock -		
no par value; 3,000,000 shares		
authorized; 812,749 and 0 shares		
issued and outstanding		
	2,604,070	-
as of December 31, 2008 and		
September 30, 2009, respectively		
Common stock - no par value;		
100,000,000 shares authorized;		
9,903,047 and 20,129,791(1) shares		
issued and outstanding as of		
December 31, 2008 and		
	13,500,034	66,434,206
September 30, 2009, respectively		
Retained earnings	1,450,711	4,252,809

Total shareholders' equity	17,554,815	70,687,015
Noncontrolling interests	--	(26,420)
Total equity	17,554,815	70,660,595
Total liabilities and equity	\$31,119,187	\$101,655,736

(1) Number of shares issued and outstanding represents total shares of common stock regardless of classification on the consolidated balance sheet. The number of shares of redeemable common stock at September 30, 2009 was 119,209.

CUMBERLAND PHARMACEUTICALS INC. ▼  
CONDENSED CONSOLIDATED STATEMENTS OF INCOME  
(UNAUDITED)

	Three months ended		Nine months ended	
	September 30,		September 30,	
	2008	2009	2008	2009
Net revenues	\$8,602,709	\$13,597,760	\$25,264,068	\$32,822,972
Costs and expenses:				
Cost of products sold	735,492	1,761,069	2,228,213	3,271,363
Selling and marketing	3,620,243	6,087,807	10,629,045	14,611,796
Research and development	730,640	640,877	2,759,042	4,041,719
General and administrative	1,167,687	2,537,627	3,272,420	5,218,925
Amortization of product license right	171,726	171,726	515,178	515,178
Other	26,413	26,595	77,635	80,791
Total costs and expenses	6,452,201	11,225,701	19,481,533	27,739,772
Operating income	2,150,508	2,372,059	5,782,535	5,083,200
Interest income	53,257	14,285	186,276	42,041
Interest expense	(48,647)	(248,272)	(172,628)	(430,207)
Net income before income taxes	2,155,118	2,138,072	5,796,183	4,695,034
Income tax expense	(946,109)	(855,660)	(2,133,501)	(1,919,356)
Net income	1,209,009	1,282,412	3,662,682	2,775,678
Net loss at subsidiary				

attributable to noncontrolling interests	-	5,725	-	26,420
	-----	-----	-----	-----
Net income attributable to common shareholders	\$1,209,009	\$1,288,137	\$3,662,682	\$2,902,098
	=====	=====	=====	=====
Earnings per share attributable to common shareholders - basic	\$0.12	\$0.08	\$0.36	\$0.23
Earnings per share attributable to common shareholders - diluted	\$0.07	\$0.07	\$0.22	\$0.16
Weighted-average shares outstanding - basic	10,165,824	15,745,069	10,128,238	12,197,876
Weighted-average shares outstanding - diluted	16,644,395	19,193,606	16,501,905	17,143,348

CUMBERLAND PHARMACEUTICALS INC. ▼  
 CONDENSED CONSOLIDATED STATEMENTS OF CASH FLOWS  
 (UNAUDITED)

	Nine Months Ended September 30,	
	-----	-----
	2008	2009
	-----	-----
Cash flows from operating activities:		
Net income	\$3,662,682	\$2,775,678
Adjustments to reconcile net income to net cash flows from operating activities:		
Gain on early extinguishment of other long-term obligations	(38,577)	-
Depreciation and amortization expense	589,721	605,514
Nonemployee stock granted for services received	104,716	205,693
Nonemployee stock option grant expense	-	840,499
Stock-based compensation - employee stock options	274,584	455,502
Excess tax benefit derived from exercise of stock options	(254,681)	(2,842,825)
Noncash interest expense	67,523	83,420
Net changes in assets and liabilities affecting operating activities:		
Accounts receivable	(828,880)	(4,054,710)
Inventory	(849,460)	75,185
Prepaid, other current assets and other assets	849,062	936,286

Accounts payable and other accrued liabilities	613,983	3,299,235
Other long-term obligations	48,681	(455,723)
	-----	-----
Net cash provided by operating activities	4,239,354	1,923,754
	-----	-----
Cash flows from investing activities:		
Additions to property and equipment	(60,996)	(199,312)
Additions to patents	(62,671)	(71,358)
	-----	-----
Net cash used in investment activities	(123,667)	(270,670)
	-----	-----
Cash flows from financing activities:		
Proceeds from initial public offering of common stock	-	85,000,000
Costs of initial public offering	(445,562)	(7,385,124)
Proceeds from borrowings on long-term debt	-	18,000,000
Principal payments on note payable	(1,375,002)	(5,000,000)
Net borrowings on line of credit	500,000	-
Payment of other long-term obligations	(2,760,000)	
Costs of financing for long-term debt and credit facility	-	(189,660)
Proceeds from exercise of stock options	59,097	64,275
Excess tax benefit derived from exercise of stock options	254,681	2,842,825
Payments made in connection with repurchase of common shares	-	(27,273,677)
	-----	-----
Net cash (used in) provided by financing activities	(3,766,786)	66,058,639
	-----	-----
Net increase in cash and cash equivalents	348,901	67,711,723
Cash and cash equivalents at beginning of period	10,814,519	11,829,551
	-----	-----
Cash and cash equivalents at end of period	\$11,163,419	\$79,541,274
	=====	=====

SOURCE Cumberland Pharmaceuticals Inc. ~

CONTACT: investors, Angela Novak, Corporate Relations of Cumberland Pharmaceuticals Inc., + 1-615-255-0068, anovak@cumberlandpharma.com; or Kathy Waller of Financial Relations Board, + 1-312-543-6708; or Media, Paula Lovell of Lovell Communications, + 1-615-297-7766, both for Cumberland Pharmaceuticals Inc. ▼

URL: <http://www.prnewswire.com>

LOAD-DATE: November 11, 2009

Source: [Command Searching > All English Language News](#) 

Terms: **5796183 or 5,796,183** (Suggest Terms for My Search)

View: Full

Date/Time: Sunday, January 26, 2014 - 4:00 PM EST



[About LexisNexis](#) | [Privacy Policy](#) | [Terms & Conditions](#) | [Contact Us](#)  
Copyright © 2014 LexisNexis, a division of Reed Elsevier Inc. All rights reserved.

REEXAM CONTROL NUMBER	FILING OR 371 (c) DATE	PATENT NUMBER
90/013,106	12/24/2013	5796183

25962  
 SLATER & MATSIL, L.L.P.  
 17950 PRESTON RD, SUITE 1000  
 DALLAS, TX 75252-5793

**CONFIRMATION NO. 9188  
 REEXAMINATION REQUEST  
 NOTICE**



Date Mailed: 01/15/2014

**NOTICE OF REEXAMINATION REQUEST FILING DATE  
 (Patent Owner Requester)**

Requester is hereby notified that the filing date of the request for reexamination is 12/24/2013, the date the required fee of \$2,520 was received. (See CFR 1.510(d)).

A decision on the request for reexamination will be mailed within three months from the filing date of the request for reexamination. (See 37 CFR 1.515(a)).

Pursuant to 37 CFR 1.33(c), future correspondence in this reexamination proceeding will be with the latest attorney or agent of the record in the patent file.

The paragraphs checked below are part of this communication:

- 1. The party receiving the courtesy copy is the latest attorney or agent of record in the patent file.
- 2. The person named to receive the correspondence in this proceeding has not been made the latest attorney or agent of record in the patent file because:
  - A. Requester's claim of ownership of the patent is not verified by the record.
  - B. The request papers are not signed with a real or apparent binding signature.
  - C. The mere naming of a correspondence addressee does not result in that person being appointed as the latest attorney or agent of record in the patent file.
- 3. Addressee is the latest attorney or agent of record in the patent file.
- 4. Other \_\_\_\_\_

/rbell/

\_\_\_\_\_  
 Legal Instruments Examiner  
 Central Reexamination Unit 571-272-7705; FAX No. 571-273-9900



REEXAM CONTROL NUMBER	FILING OR 371 (c) DATE	PATENT NUMBER
90/013,106	12/24/2013	5796183

25962  
SLATER & MATSIL, L.L.P.  
17950 PRESTON RD, SUITE 1000  
DALLAS, TX 75252-5793

**CONFIRMATION NO. 9188**  
**REEXAM ASSIGNMENT NOTICE**



Date Mailed: 01/15/2014

### NOTICE OF ASSIGNMENT OF REEXAMINATION REQUEST

The above-identified request for reexamination has been assigned to Art Unit 3992. All future correspondence to the proceeding should be identified by the control number listed above and directed to the assigned Art Unit.

A copy of this Notice is being sent to the latest attorney or agent of record in the patent file or to all owners of record. (See 37 CFR 1.33(c)). If the addressee is not, or does not represent, the current owner, he or she is required to forward all communications regarding this proceeding to the current owner(s). An attorney or agent receiving this communication who does not represent the current owner(s) may wish to seek to withdraw pursuant to 37 CFR 1.36 in order to avoid receiving future communications. If the address of the current owner(s) is unknown, this communication should be returned within the request to withdraw pursuant to Section 1.36.

/rbell/

---

Legal Instruments Examiner  
Central Reexamination Unit 571-272-7705; FAX No. 571-273-9900

## Patent Assignment Abstract of Title

### Total Assignments: 5

Application #: 08601268 Filing Dt: 01/31/1996 Patent #: 5796183 Issue Dt: 08/18/1998  
PCT #: NONE Publication #: NONE Pub Dt:  
Inventors: JOHN M. WASHELESKI, STEPHEN R. W. COOPER, BYRON HOURMAND  
Title: CAPACITIVE RESPONSIVE ELECTRONIC SWITCHING CIRCUIT

### Assignment: 1

Reel/Frame: 008254 / 0496 Received: 02/10/1997 Recorded: 01/31/1996 Mailed: 02/12/1997 Pages: 2

Conveyance: ASSIGNMENT OF ASSIGNORS INTEREST (SEE DOCUMENT FOR DETAILS).

Assignor: HOURMAND, BYRON

Exec Dt: 01/31/1996

Assignee: NARTRON CORPORATION

5000 NORTH U.S. 131  
REED CITY, MICHIGAN 49677

Correspondent: PRICE, HENEVELD, COOPER,  
DEWITT & LITTON  
TERRY S. CALLAGHAN, ESQ.  
P.O. BOX 2567  
GRAND RAPIDS, MI 49501

### Assignment: 2

Reel/Frame: 008443 / 0749 Received: 04/17/1997 Recorded: 02/04/1997 Mailed: 05/28/1997 Pages: 2

Conveyance: ASSIGNMENT OF ASSIGNORS INTEREST (SEE DOCUMENT FOR DETAILS).

Assignor: HOURMAND, BYRON

Exec Dt: 01/31/1996

Assignee: NARTRON CORPORATION

5000 NORTH US 131  
REED CITY, MICHIGAN 49677

Correspondent: PRICE, HENEVELD, COOPER, ET AL  
TERRY S. CALLAGHAN, ESQ.  
P.O. BOX 2567  
GRAND RAPIDS, MI 49501

### Assignment: 3

Reel/Frame: 023679 / 0803 Received: 12/22/2009 Recorded: 12/22/2009 Mailed: 12/23/2009 Pages: 11

Conveyance: ASSIGNMENT OF ASSIGNORS INTEREST (SEE DOCUMENT FOR DETAILS).

Assignor: NARTRON CORPORATION

Exec Dt: 12/17/2009

Assignee: UUSI, LLC

5000 NORTH US HIGHWAY 131  
REED CITY, MICHIGAN 49677

Correspondent: TAROLLI, SUNDHEIM, COVELL & TUMMINO LLP  
1300 EAST NINTH STREET  
SUITE 1700  
CLEVELAND, OH 44114

### Assignment: 4

Reel/Frame: 028804 / 0075 Received: 08/17/2012 Recorded: 08/17/2012 Mailed: 08/20/2012 Pages: 2

Conveyance: ASSIGNMENT OF ASSIGNORS INTEREST (SEE DOCUMENT FOR DETAILS).

Assignor: WASHELESKI, JOHN M.

Exec Dt: 04/14/2010

Assignee: NARTRON CORPORATION

5000 NORTH US-131  
REED CITY, MICHIGAN 49677

Correspondent: SLATER & MATSIL, L.L.P.  
17950 PRESTON RD.  
SUITE 1000  
DALLAS, TX 75252

### Assignment: 5

**Reel/Frame:** 028804 / 0137    **Received:** 08/17/2012    **Recorded:** 08/17/2012    **Mailed:** 08/20/2012    **Pages:** 2

**Conveyance:** ASSIGNMENT OF ASSIGNORS INTEREST (SEE DOCUMENT FOR DETAILS).

**Assignor:** COOPER, STEPHEN R.W.

**Exec Dt:** 04/14/2010

**Assignee:** NARTRON CORPORATION  
5000 NORTH US-131  
REED CITY, MICHIGAN 49677

**Correspondent:** SLATER & MATSIL, L.L.P.  
17950 PRESTON RD.  
SUITE 1000  
DALLAS, TX 75252

Search Results as of: 12/30/2013 02:39 PM

---

If you have any comments or questions concerning the data displayed, contact PRD / Assignments at 571-272-3350. v.2.2.4  
Web interface last modified: Jul 8, 2013 v.2.2.4

(Also referred to as FORM PTO-1465)

**REQUEST FOR EX PARTE REEXAMINATION TRANSMITTAL FORM**

Address to:

**Mail Stop Ex Parte Reexam**  
**Commissioner for Patents**  
**P.O. Box 1450**  
**Alexandria, VA 22313-1450**

Attorney Docket No.: **5796183RX2**Date: **12/24/2013**

1.  This is a request for *ex parte* reexamination pursuant to 37 CFR 1.510 of patent number 5,796,183 B1 issued August 18, 1998. The request is made by:
- patent owner.  third party requester.
2.  The name and address of the person requesting reexamination is:
- UUSI, LLC  
5000 North US Highway 131, 22nd Floor  
Reed City, Michigan 49677
3. Requester claims  small entity (37 CFR 1.27) or  micro entity status (37 CFR 1.29) -- only a patent owner requester can claim micro entity status.
4.  a. A check in the amount of \$ \_\_\_\_\_ is enclosed to cover the reexamination fee, 37 CFR 1.20(c)(1);
- b. The Director is hereby authorized to charge the fee as set forth in 37 CFR 1.20(c)(1) to Deposit Account No. 50-1065;
- c. Payment by credit card. Form PTO-2038 is attached; or
- d. Payment made via EFS-Web.
5.  Any refund should be made by  check or  credit to Deposit Account No. 50-1065 37 CFR 1.26(c). If payment is made by credit card, refund must be to credit card account.
6.  A copy of the patent to be reexamined having a double column format on one side of a separate paper is enclosed. 37 CFR 1.510(b)(4).
7.  CD-ROM or CD-R in duplicate, Computer Program (Appendix) or large table  
 Landscape Table on CD
8.  Nucleotide and/or Amino Acid Sequence Submission  
*If applicable, items a. -- c. are required.*
- a.  Computer Readable Form (CRF)
- b. Specification Sequence Listing on:
- i.  CD-ROM (2 copies) or CD-R (2 copies); or
- ii.  paper
- c.  Statements verifying identity of above copies
9.  A copy of any disclaimer, certificate of correction or reexamination certificate issued in the patent is included.
10.  Reexamination of claim(s) 18 and 27 is requested.
11.  A copy of every patent or printed publication relied upon is submitted herewith including a listing thereof on Form PTO/SB/08, PTO-1449, or equivalent.
12.  An English language translation of all necessary and pertinent non-English language patents and/or printed publications is included.

[Page 1 of 2]

This collection of information is required by 37 CFR 1.510. The information is required to obtain or retain a benefit by the public which is to file (and by the USPTO to process) an application. Confidentiality is governed by 35 U.S.C. 122 and 37 CFR 1.11 and 1.14. This collection is estimated to take 18 minutes to complete, including gathering, preparing, and submitting the completed application form to the USPTO. Time will vary depending upon the individual case. Any comments on the amount of time you require to complete this form and/or suggestions for reducing this burden, should be sent to the Chief Information Officer, U.S. Patent and Trademark Office, U.S. Department of Commerce, P.O. Box 1450, Alexandria, VA 22313-1450. DO NOT SEND FEES OR COMPLETED FORMS TO THIS ADDRESS. SEND TO: **Mail Stop Ex Parte Reexam, Commissioner for Patents, P.O. Box 1450, Alexandria, VA 22313-1450.**

*If you need assistance in completing the form, call 1-800-PTO-9199 and select option 2.*

Under the Paperwork Reduction Act of 1995, no persons are required to respond to a collection of information unless it displays a valid OMB control number.

13.  The attached detailed request includes at least the following items:

a. A statement identifying each substantial new question of patentability based on prior patents and printed publications. 37 CFR 1.510(b)(1).

b. An identification of every claim for which reexamination is requested, and a detailed explanation of the pertinency and manner of applying the cited art to every claim for which reexamination is requested. 37 CFR 1.510(b)(2).

14.  A proposed amendment is included (only where the patent owner is the requester). 37 CFR 1.510(e).

15.  a. It is certified that a copy of this request (if filed by other than the patent owner) has been served in its entirety on the patent owner as provided in 37 CFR 1.33(c).  
The name and address of the party served and the date of service are:  
\_\_\_\_\_  
\_\_\_\_\_  
Date of Service: \_\_\_\_\_; or

b. A duplicate copy is enclosed since service on patent owner was not possible. An explanation of the efforts made to serve patent owner is attached. See MPEP § 2220.

16. Correspondence Address: Direct all communication about the reexamination to:

The address associated with Customer Number: 25962

OR

Firm or Individual Name \_\_\_\_\_  
Address \_\_\_\_\_

City	State	Zip
Country		
Telephone	Email	

17.  The patent is currently the subject of the following concurrent proceeding(s):

a. Copending reissue Application No. \_\_\_\_\_

b. Copending reexamination Control No. \_\_\_\_\_

c. Copending Interference No. \_\_\_\_\_

d. Copending litigation styled: \_\_\_\_\_

\_\_\_\_\_

**WARNING: Information on this form may become public. Credit card information should not be included on this form. Provide credit card information and authorization on PTO-2038.**

/Brian A. Carlson/ \_\_\_\_\_ December 24, 2013 \_\_\_\_\_  
Authorized Signature Date

Brian A. Carlson \_\_\_\_\_ 37,793 \_\_\_\_\_  
Typed/Printed Name Registration No.  For Patent Owner Requester

For Third Party Requester

## Privacy Act Statement

The **Privacy Act of 1974 (P.L. 93-579)** requires that you be given certain information in connection with your submission of the attached form related to a patent application or patent. Accordingly, pursuant to the requirements of the Act, please be advised that: (1) the general authority for the collection of this information is 35 U.S.C. 2(b)(2); (2) furnishing of the information solicited is voluntary; and (3) the principal purpose for which the information is used by the U.S. Patent and Trademark Office is to process and/or examine your submission related to a patent application or patent. If you do not furnish the requested information, the U.S. Patent and Trademark Office may not be able to process and/or examine your submission, which may result in termination of proceedings or abandonment of the application or expiration of the patent.

The information provided by you in this form will be subject to the following routine uses:

1. The information on this form will be treated confidentially to the extent allowed under the Freedom of Information Act (5 U.S.C. 552) and the Privacy Act (5 U.S.C. 552a). Records from this system of records may be disclosed to the Department of Justice to determine whether disclosure of these records is required by the Freedom of Information Act.
2. A record from this system of records may be disclosed, as a routine use, in the course of presenting evidence to a court, magistrate, or administrative tribunal, including disclosures to opposing counsel in the course of settlement negotiations.
3. A record in this system of records may be disclosed, as a routine use, to a Member of Congress submitting a request involving an individual, to whom the record pertains, when the individual has requested assistance from the Member with respect to the subject matter of the record.
4. A record in this system of records may be disclosed, as a routine use, to a contractor of the Agency having need for the information in order to perform a contract. Recipients of information shall be required to comply with the requirements of the Privacy Act of 1974, as amended, pursuant to 5 U.S.C. 552a(m).
5. A record related to an International Application filed under the Patent Cooperation Treaty in this system of records may be disclosed, as a routine use, to the International Bureau of the World Intellectual Property Organization, pursuant to the Patent Cooperation Treaty.
6. A record in this system of records may be disclosed, as a routine use, to another federal agency for purposes of National Security review (35 U.S.C. 181) and for review pursuant to the Atomic Energy Act (42 U.S.C. 218(c)).
7. A record from this system of records may be disclosed, as a routine use, to the Administrator, General Services, or his/her designee, during an inspection of records conducted by GSA as part of that agency's responsibility to recommend improvements in records management practices and programs, under authority of 44 U.S.C. 2904 and 2906. Such disclosure shall be made in accordance with the GSA regulations governing inspection of records for this purpose, and any other relevant (*i.e.*, GSA or Commerce) directive. Such disclosure shall not be used to make determinations about individuals.
8. A record from this system of records may be disclosed, as a routine use, to the public after either publication of the application pursuant to 35 U.S.C. 122(b) or issuance of a patent pursuant to 35 U.S.C. 151. Further, a record may be disclosed, subject to the limitations of 37 CFR 1.14, as a routine use, to the public if the record was filed in an application which became abandoned or in which the proceedings were terminated and which application is referenced by either a published application, an application open to public inspection or an issued patent.
9. A record from this system of records may be disclosed, as a routine use, to a Federal, State, or local law enforcement agency, if the USPTO becomes aware of a violation or potential violation of law or regulation.

**IN THE UNITED STATES PATENT AND TRADEMARK OFFICE**

U.S. Patent No.:	5,796,183 B1	§	Docket No.:	5796183RX2
Issued:	August 18, 1998	§	Inventors:	Hourmand et al.
Filed:	January 31, 1996	§	Patent Owner:	UUSI, LLC
Control No.	TBD	§	Examiner:	TBD

For: Capacitive Responsive Electronic Switching Circuit

Mail Stop *Ex Parte* Reexam  
Attn: Central Reexamination Unit  
Commissioner for Patents  
P.O. Box 1450  
Alexandria, VA 22313-1450

**REQUEST FOR *EX PARTE* REEXAMINATION UNDER 35 U.S.C. §§ 302-307**

Dear Sir:

Patent Owner UUSI, LLC respectfully requests *Ex Parte* Reexamination, pursuant to the provisions of 35 U.S.C. §§ 302–307 (2002), of claims 18 and 27 of United States Patent No. 5,796,183 C1 (the “`183 Patent”). This patent is still enforceable.

As set forth below, some of the prior art references submitted herewith were not previously before the Office, and the combination of these references with previously considered references presents new, non-cumulative technological teachings not considered during the `183 Patent prosecution history including the first reexamination proceeding having control number 90/012,439.

**I. OVERVIEW OF THE `183 PATENT AND ITS PROSECUTION HISTORY**

Section I.A below provides an overview of the subject matter of the `183 Patent, while Section I.B provides an overview of its prosecution history.

**A. The `183 Patent**

The `183 Patent, a copy of which is provided as Exhibit A, issued on August 18, 1998 from an application filed on January 31, 1996. Ex Parte Reexamination Certification Number 5,796,183 C1 was issued for the `183 Patent on April 29, 2013. The `183 Patent generally relates to a capacitive responsive electronic switching circuit including an oscillator providing a periodic output signal, an input touch terminal defining an area for an operator to provide an input by proximity and touch, and a detector circuit coupled to the oscillator for receiving the periodic output signal from the oscillator, and coupled to the input touch terminal. *See, e.g.*, `183 Patent, Abstract.

The `183 Patent as reexamined contains 39 total claims, with claims 1, 9, 12, 16, 18, 20, 24, 27, and 37 being independent. Claims 18 and 27, which are the subject of this reexam request, require an oscillator, a microcontroller, a plurality of touch terminals, and a detector circuit.

An embodiment with a single touch terminal is shown in Figure 4, and an embodiment with multiple touch terminals is shown in Figure 11, both of which are reproduced below:



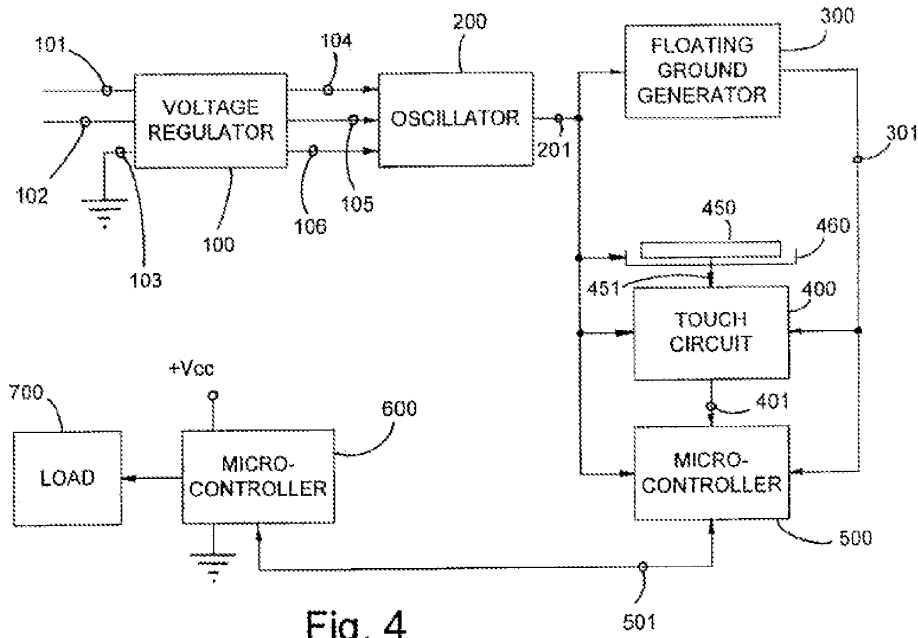

Fig. 4

Fig. 4 of the '183 Patent

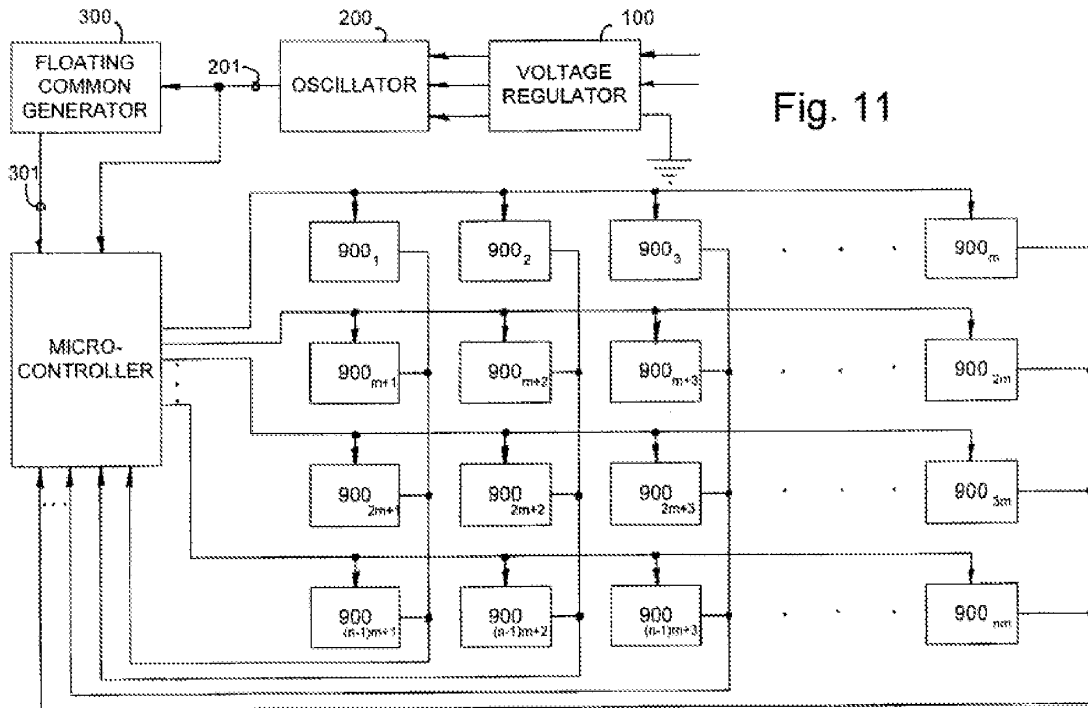

Fig. 11

Fig. 11 of the '183 Patent

The multiple touch pad circuit of Figure 11 is a variation of the embodiment shown in Figure 4, but with an array of touch circuits designated as 900<sub>1</sub> through 900<sub>nm</sub>. *See, e.g., id.* at col. 18:34-43. The touch detection circuit offers improvements in detection sensitivity that allow close control of the degree of proximity (ideally very close proximity) that is required for actuation and to enable employment of a multiplicity of small sized touch terminals in a physically close array such as a keyboard. *See, e.g., id.* at col. 5:53-57.

Microcontroller 500 selects each row of the touch circuits 900<sub>1</sub> to 900<sub>nm</sub> by providing the signal from oscillator 200 to selected rows of touch circuits. *See, e.g., id.* at col. 18:43-46. The values of the resistors and capacitors utilized in oscillator 200 may be varied to provide for different oscillator output frequencies. *See, e.g., id.* at col. 14:22-25. Although the preferred frequency is at or above 100 kHz, and more preferably at or above 800 kHz, it is conceivable that frequencies as low as 50 kHz could be used provided the frequency creates a difference in the impedance paths of adjacent pads that is sufficient enough to accurately distinguish between an intended touch and the touch of an adjacent pad. *See, e.g., id.* at col. 11:19-25.

Microcontroller 500 sequentially activates the touch circuit rows and associates the received inputs from the columns of the array with the activated touch circuit(s). *See, e.g., id.* at col. 18:46-49. The detector circuit is responsive to signals from the oscillator and the presence of an operator's body capacitance to ground coupled to the touch terminal when in proximity or touched by an operator to provide a control output signal. *See, e.g., id.* at Abstract. Another method for implementing capacitive touch switches relies on the change in capacitive coupling between a touch terminal and ground. *See, e.g., id.* at col. 3:44-46.

**B. The Prosecution History of the `183 Patent**

A copy of selected portions of the prosecution history of the `183 Patent is provided in Exhibit B.

The `183 Patent issued from U.S. Patent Application Serial No. 08/601,268 (“the `268 application”), filed on January 31, 1996, and naming Byron Hourmand as the sole inventor. A request for ex parte reexamination of the `183 Patent was filed on August 17, 2012 and assigned control number 90/012,439. Ex Parte Reexamination Certificate No. 5,796,183 C1 was thereafter issued on April 29, 2013.

The `268 application was filed with 20 total claims, of which four were independent. Claims 21-32 were added by subsequent amendment. A cross-reference between the originally issued claims and the application claims from which they issued is provided below for convenience.

Issued Claim	Appl. Claim	Issued Claim	Appl. Claim	Issued Claim	Appl. Claim	Issued Claim	Appl. Claim
1	1	9	5	17	16	25	25
2	2	10	6	18	18	26	26
3	3	11	7	19	19	27	27
4	4	12	12	20	20	28	28
5	8	13	13	21	21	29	29
6	9	14	14	22	22	30	30
7	10	15	17	23	23	31	31
8	11	16	15	24	24	32	32

In an Office Action dated April 22, 1997, the Examiner rejected application claims 6, 7 and 16 under 35 U.S.C. § 112, second paragraph, as being indefinite. *See* Ex. B, `183 Patent File History, Office Action, p. 2 (Apr. 22, 1997). Claims 6, 7 and 16 would be allowable if rewritten to overcome the section 112 rejection, and to include all of the limitations of the base claim and any intervening claims. *See id.* at p. 5.

Claims 1-4 and 12-14 were rejected under 35 U.S.C. § 102(b) as being anticipated by U.S. Patent No. 4,352,141 to Kent (“Kent”). *See id.* Claims 8-11, 18, and 19 were rejected under 35 § U.S.C. 103(a) as being unpatentable over Kent in view of U.S. Patent No. 5,087,825 to Ingraham (“Ingraham”), *see id.* at p. 3, and claims 8-11, 18 and 19 were rejected under 35 U.S.C. § 103(a) as being unpatentable over Kent in view of U.S. Patent No. 5,235,217 to Kirton (“Kirton”). *See id.* at p. 4. Lastly, claims 5 and 15 were objected to as being dependent upon a rejected base claim, but would be allowable if rewritten in independent form including all the limitations of the base claim and any intervening claims. *See id.* at p. 5.

In response, the Applicant filed an amendment on August 22, 1997, amending claims 1, 3, 5, 6, 12-18 and 20, and adding new claims 21-32. In particular, the Applicant amended independent claim 18 as follows:

18. (Amended) A capacitive responsive electronic switching circuit comprising:  
an oscillator providing a periodic output signal having a predefined frequency;  
a plurality of input touch terminals defining adjacent areas on a dielectric substrate for an operator to provide inputs by proximity and touch; and  
a detector circuit coupled to said oscillator for receiving said periodic output signal from said oscillator, and coupled to said input touch terminals, said detector circuit being responsive to signals from said oscillator and the presence of an operator's body capacitance to ground coupled said touch terminals when proximal or touched by an operator to provide a control output signal,  
wherein said predefined frequency of said oscillator is selected to decrease the impedance of said dielectric substrate relative to the impedance of any contaminate that may create an electrical on said dielectric substrate path between said adjacent areas, and wherein said detector circuit compares the sensed body capacitance to ground proximate an input touch terminal to a threshold level to prevent inadvertent generation of the control output signal.

Ex. B, `183 Patent File History, Amendment, p. 11 (Aug. 22, 1997). The Applicant argued that the Kent and Ingraham patents both fail to teach or suggest a capacitive responsive electronic switching circuit comprising a detector circuit that compares the sensed body capacitance proximate an input touch terminal to a threshold level in order to prevent inadvertent generation

of a control output signal. *See id.* at p. 19. The Applicant further argued that the Kirton patent, like the Kent and Ingraham patents, does not disclose a touch control circuit that is capable of discriminating between a full intentional touch of a touch terminal and an inadvertent touch of a portion of the surface of the touch terminal. *See id.*

With respect to new independent claim 27, the Applicant argued none of the cited references teaches or suggests a switching circuit for a control device that comprises at least first and second touch terminals and a detector circuit that generates a control output signal for actuation of the control device when an operator is proximal or touches the second touch terminal after the operator is proximal or touches the first touch terminal. *See id.* at pp. 20-21.

The Examiner issued a Notice of Allowance on October 27, 1997, allowing all of the pending claims. *See Ex. B, `183 Patent File History, Notice of Allowance, p. 2 (Oct. 27, 1997).* The Applicant then filed a section 312 amendment on November 3, 1997 to delete the word “said” after the word “when” in claim 27, line 11. *See Ex. B, `183 Patent File History, Amendment Under 37 C.F.R. § 1.312, p. 1 (Nov. 3, 1997).* The issue fee was paid on January 26, 1998, *see Ex. B, `183 Patent File History, Issue Fee Transmittal, p. 1 (Jan. 26, 1998),* and the `183 Patent subsequently issued on August 18, 1998.

The Applicant filed a certificate of correction on January 20, 1999, which was accepted by the patent office on May 11, 1999. In claim 18, the word “path” was inserted after the word “electrical” in column 27, line 44 of the `183 Patent, and the word “path” was deleted from column 27, line 45 of the `183 Patent. *See Ex. B, `183 Patent File History, Cert. of Correction, p. 3 (May 11, 1999).* In claim 27, the word “said” was deleted after the word “when.” *See id.*

The Patent Owner subsequently made several attempts to correct the inventorship of the patent, which resulted in the inventorship being changed to be Byron Hourmand, John M.

Washeleski and Stephen R. W. Cooper. *See* Ex. B, `183 Patent File History, Petition Decision (Aug. 25, 2011); *see also* Corrected Filing Receipt, p. 1 (Aug. 25, 2011); Certificate of Correction (Oct. 11, 2011).

On August 17, 2012, the Patent Owner filed a request for *ex parte* reexamination of claims 18 and 27 of the `183 Patent. *See* Ex. B, `183 Patent File History, Request for *Ex Parte* Reexamination under 35 U.S.C. §§ 302-307 (Aug. 17, 2012). The reexamination request was granted on September 20, 2012 and assigned control number 90/012,439. *See* Ex. B, `183 Patent File History, Order Granting / Denying Request for *Ex Parte* Reexamination (Sep. 20, 2012). Thereafter, the Patent Owner filed a Patent Owner Statement amending claims 18, 27, 28, and 32 and adding claims 33-39. *See* Ex. B, `183 Patent File History, Patent Owner Statement (Nov. 19, 2012).

In the Patent Owner Statement, claim 18 was amended to recite “a microcontroller using the periodic output signal from the oscillator, the microcontroller selectively providing signal output frequencies to a plurality of small sized input touch terminals of a keypad.” *See id.* at p. 2. Claim 27 was amended to recite “a microcontroller using the periodic output signal from the oscillator, the microcontroller selectively providing signal output frequencies to a closely spaced array of input touch terminals of a keypad, the input touch terminals comprising first and second input touch terminals.” *See id.* at p. 3. New independent claim 37 recited “a microcontroller using the periodic output signal from the oscillator, the microcontroller selectively providing signal output frequencies to a closely spaced array of input touch terminals of a keypad, the input touch terminals comprising first and second input touch terminals.” *See id.* at p. 5. The Patent Owner argued that the cited art, U.S. Patent No. 5,463,388 (“Boie”), does not teach or suggest these claim elements. *See id.* at pp. 7-9.

In the Statement of Reasons for Patentability and/or Confirmation, the Examiner agreed with the Patent Owner that Boie does not teach or suggest these elements. *See* Ex. B, `183 Patent File History, Notice of Intent to Issue Ex Parte Reexamination Certificate (Apr. 10, 2013), pp. 3-4. The Examiner stated, “Boie discloses driving the electrodes of electrode array 100 and guard plane 411 with a single RF signal. Boie does not teach or suggest providing signal output frequencies to these components.” *See id.* at p. 4.

The Ex Parte Reexamination Certificate thereafter issued on April 29, 2013. *See* Ex. A, Ex Parte Reexamination Certificate (Apr. 29, 2013).

## **II. SUBSTANTIAL NEW QUESTION (“SNQ”) OF PATENTABILITY**

Section II.A below provides a list of the prior art references relied upon in the present request. Section II.B provides an overview of the prior art references. Section II.C provides a statement regarding an SNQ of patentability for claims 18 and 27 of the `183 Patent with respect to the new references.

### **A. Listing of Prior Art Patents and Publications**

Reexamination of claims 18 and 27 of the `183 Patent is requested in view of the following references:

- Exhibit C Boie et al., U.S. Patent No. 5,463,388, filed on January 29, 1993 and issued on October 31, 1995 (“Boie”), which qualifies as 35 U.S.C. § 102(a)-type prior art.
- Exhibit D Gerpheide et al., U.S. Patent No. 5,565,658, filed on December 7, 1994 and issued on October 15, 1996 (“Gerpheide”), which qualifies as 35 U.S.C. § 102(e)-type prior art.
- Exhibit E Casio advertisement entitled “Now... The Invisible Casio Calculator Watch,” published in *Popular Science* by On the Run in 1984 (“Casio”), which qualifies as 35 U.S.C. § 102(b)-type prior art.

### **B. Overview of Prior Art Patents and Publications**

As discussed in more detail below, combinations of Boie, Gerpheide, and Casio present new, non-cumulative technological teachings not considered during the `183 Patent prosecution history.

#### **1. Boie**

Boie generally relates to sensors for capacitively sensing the position or movement of an object, such as a finger, on a surface. *See, e.g.*, Boie, col. 1:6-8. A computer input device comprises a thin, insulating surface covering an array of electrodes arranged in a grid pattern and connected in columns and rows. *See, e.g., id.* at Abstract. Each column and row is connected to



circuitry for measuring the capacitance seen by each column and row. *See, e.g., id.* The position of an object with respect to the array is determined from the centroid of such capacitance values, which is calculated in a microcontroller. *See, e.g., id.* Figure 4, reproduced below, illustrates a block diagram of a two-dimensional capacitive position sensor.

FIG. 4

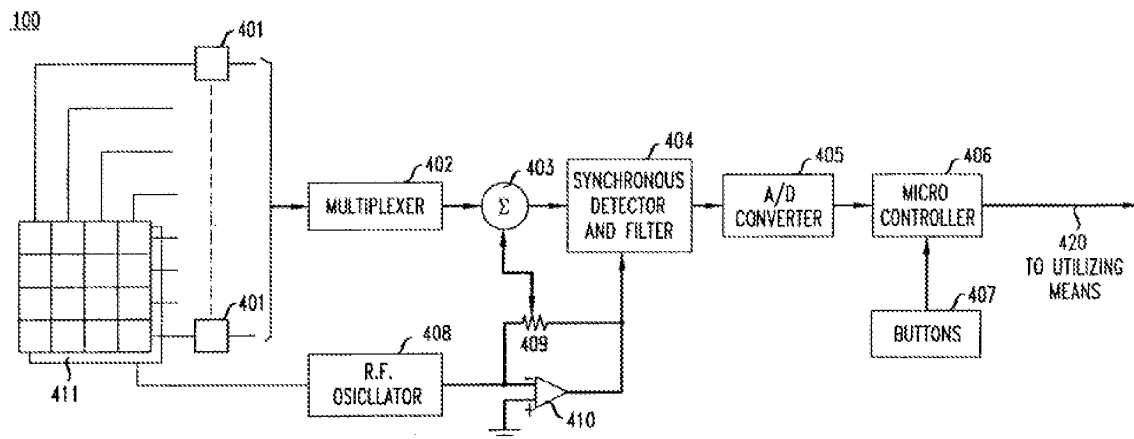

Fig. 4 of Boie

Each row and column of electrodes from array 100 is connected to an integrating amplifier and bootstrap circuit 401, each of which can be selected by multiplexer 402 under control of microcontroller 406. *See, e.g., id.* at col. 3:56-61. The selected output is forwarded to summing circuit 403, the output of which is converted by synchronous detector and filter 404 to a signal related to the capacitance of the row or column selected by multiplexer 402. *See, e.g., id.* at col. 3:62-67. RF oscillator 408 provides an RF signal of, for example, 100 kilohertz, to circuits 401, synchronous detector and filter 404 via inverter 410, and guard plane 411, which is a substantially continuous plane parallel to array 100 and associated connections, and serves to isolate array 100 from extraneous signals. *See, e.g., id.* at col. 3:67-col. 4:5.

To measure separate capacitance values for each electrode in array 100 instead of the collective capacitances of subdivided electrode elements connected in rows and columns, a circuit 401 is provided for each electrode in array 100 and multiplexer 402 is enlarged to accommodate the outputs from all circuits 401. *See, e.g., id.* at col. 4:14-21. The output of synchronous detector and filter 404 is converted to digital form by analog-to-digital converter 405 and forwarded to microcontroller 406 so that microcontroller 406 obtains a digital value representing the capacitance seen by any row or column of electrode elements (or electrode if measured separately) selected by multiplexer 402. *See, e.g., id.* at col. 4:22-28.

## 2. Gerpheide

Gerpheide generally relates to the rejection of electrical interference in capacitance-based touch detection apparatuses and methods. *See, e.g.,* Gerpheide, col. 1:12-14. In discussing the shortcomings of the prior art, Gerpheide states

[A] capacitance-based detection device may suffer from electrical background interference from its surroundings, which is coupled onto the sensing electrodes and interferes with position detection. These spurious signals cause troublesome interference with the detection of finger positioning. The device operator may even act as an antenna for electrical interference which may cause a false charge injection or depletion from the detecting electrodes. Accordingly, there is a need for a touch detection system which has the following characteristics: ... (3) electrical interference signals are rejected and eliminated from the detection system regardless of their frequency and without requiring possibly expensive nulling apparatus.

*Id.* at col. 2:37-57.

Figure 1 of Gerpheide (reproduced below) illustrates a capacitance variation finger (or other conductive body or non-body part) position sensing system 10 that includes an electrode array 12, a synchronous electrode capacitance measurement unit 14, a reference frequency generator 16, and a position locator 18. *See id.* at col. 3:52 – col. 4:26.

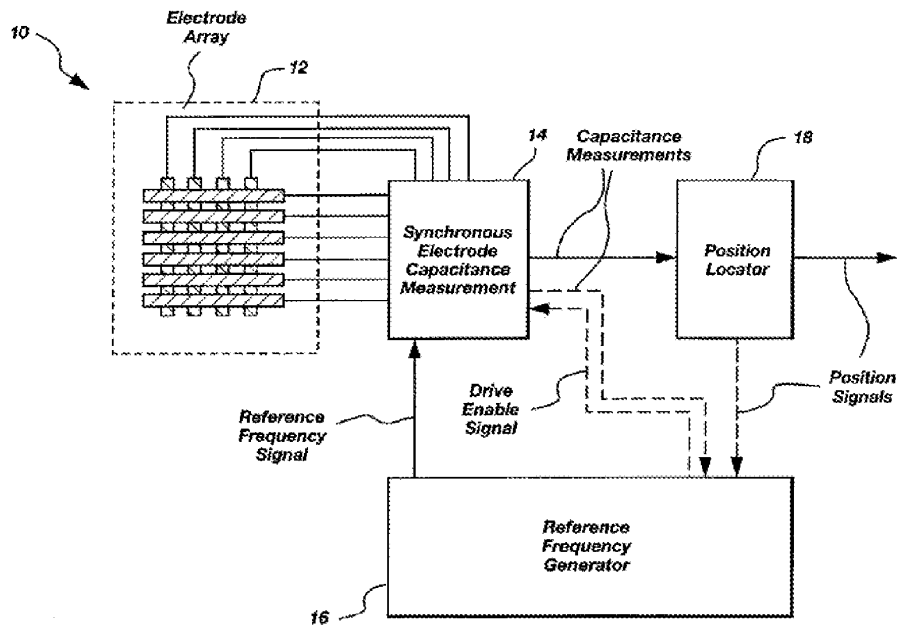
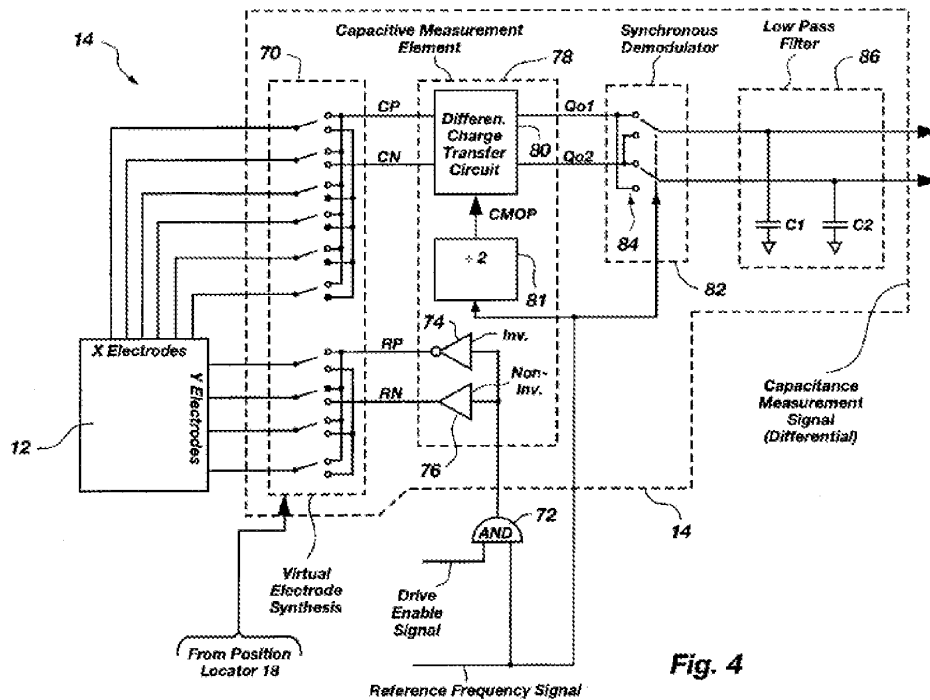

**Fig. 1**

Gerpheide, Figure 1

The electrode array 12 is described in relation to Figures 2a and 2b. *See generally id.* at col. 4:41 – col. 5:48; Figs. 2a and 2b. In Gerpheide, electrode array 12 consists of multiple X electrodes 20 and Y electrodes 22 and is preferably fabricated as a multi-layer printed circuit board 24. *See id.* at col. 4:41-48.

The synchronous electrode capacitance measurement unit 14 is connected to the electrode array 12 and one embodiment is further described with reference to Figure 4, reproduced below.



Gerpheide, Figure 4

According to Gerpheide,

The key elements of the synchronous electrode capacitance measurement unit 14 are (a) an element for producing a voltage change in the electrode array synchronously with a reference signal, (b) an element producing a signal indicative of the displacement charge thereby coupled between electrodes of the electrode array, (c) an element for demodulating this signal synchronously with the reference signal, and (d) an element for low pass filtering the demodulated signal.

*See id.* at col. 5:52-63; Fig. 4.

The reference frequency signal is preferably a digital logic signal from the reference frequency generator 16 (FIG. 1). The reference frequency signal is supplied to unit 14 via an AND gate 72 also having a "drive enable" input, supplied by the reference frequency generator 16 (FIG. 1). The AND gate output feeds through inverter 74 and noninverting buffer 76 to wires RP and RN respectively which are part of a capacitive measurement element 78.

*See id.* at col. 6:19-26; Fig. 4. The reference frequency generator 16 "observes position signals to evaluate the extent of interference at some reference frequency. In the event that substantial

interference is detected, the generator 16 selects a different frequency for further measurements. The generator 16 seeks to always select a reference frequency away from frequencies which have been found to result in measurement interference.” *See id.* at col. 8:22-30; Fig. 7. Reference frequency generator 16 is further illustrated with respect to Figure 7, reproduced below.

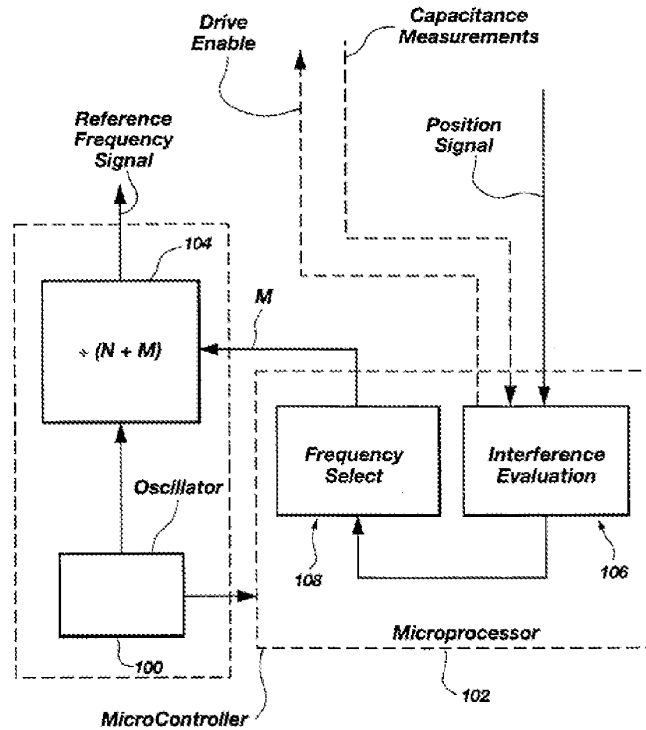

Fig. 7

Gerpheide, Figure 7

The generator 16 includes an oscillator 100. *See id.* at col. 8:31. The oscillator 100 drives a microcontroller 102 and a divide-by-(M+N) circuit 104. *See id.* at col. 8:31-33. Value N is a fixed constant, for example, approximately 50. *See id.* at col. 8:33-34. Microcontroller 102 specifies value M to be, for example, one of four values in the range 61 KHz to 80 KHz. *See id.* at col. 8:34-36. The microcontroller 102 performs the functions of interference evaluation 106 and frequency selection 108. *See id.* at col. 8:37-38.

### 3. Casio

Casio generally relates to a timepiece product employing electro-touch technology. *See, e.g.*, Casio, col. 1. The watch works by reading finger-strokes traced across its face. *See id.* The transparent touch panel construction includes a fiberglass panel having a transparent conductor film pattern (first layer) and a dielectric layer (second layer) overlying the fiberglass. *See id.* at col. 2; *see also* Figure in col. 2 (reproduced below).

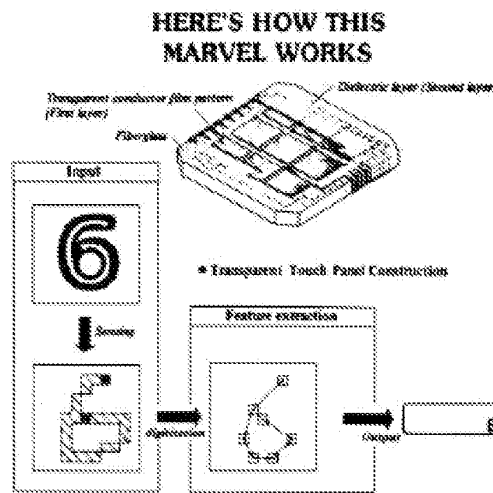

*Id.*, col. 2.

The touch panel determines figure and math symbols outlined with finger-strokes traced across the face. *See id.* at col. 1. As shown in the figure above, the touch panel senses the input, and then digitizes it to extract features of the figure or math symbol. *See id.* at col. 2. The watch then outputs the corresponding figure or math symbol on the screen. *See id.* The advertisement states

This ... timepiece has a transparent crystal that reads finger-strokes you trace across its face. Each figure and math symbol you outline appears on the background digital display. Take your finger across twice (=) and the answer presents itself like magic.

No keys, no keyboards, no need to use stylus or pen. Even the broadest fingers will work. Add, subtract, multiply, divide – perform chain and mixed calculations

to eight places, plus decimal. There's even an indicator telling you which function is being performed.

*See id.* at col. 1.

**C. Statement Pointing Out Each SNQ of Patentability**

Boie was not cited during the original patent prosecution of the `183 Patent and was cited as an anticipatory reference in the first reexamination proceeding. The combination of Boie with Gerpheide and/or Casio presents new, non-cumulative technological teachings with respect to claims 18 and 27 of the `183 Patent.

**1. Claim 18**

During the first reexamination prosecution, the Patent Owner amended independent claim 18 to recite “a microcontroller using the periodic output signal from the oscillator, the microcontroller selectively providing signal output frequencies to a plurality of small sized input touch terminals of a keypad,” and argued that the cited art did not teach or suggest these limitations. After the Patent Owner made this amendment, the Examiner allowed claim 18 stating, “Boie discloses driving the electrodes of electrode array 100 and guard plane 411 with a single RF signal. Boie does not teach or suggest providing signal output frequencies to these components.” *See* Ex. B, `183 Patent File History, Notice of Intent to Issue *Ex Parte* Reexamination Certificate, p.4 (Apr. 10, 2013).

Gerpheide discloses,

[A reference frequency generator 16] observes position signals to evaluate the extent of interference at some reference frequency. In the event that substantial interference is detected, the generator 16 selects a different frequency for further measurements. The generator 16 seeks to always select a reference frequency away from frequencies which have been found to result in measurement interference, as described below. The generator 16 includes an oscillator 100 which is, for example, set at four MHz, driving a microcontroller 102 and a divide-by-(M+N) circuit 104. Value N is a fixed constant, approximately 50. Value M is specified by the microcontroller 102 to be, for example, one of four values in the range 61 KHz to 80 KHz as specified by the microcontroller 102.

The microcontroller 102 performs the functions of interference evaluation 106 and frequency selection 108.

Gerpheide, col. 8:22-38; Fig. 7. Thus, Gerpheide discloses selectively providing signal output frequencies.

It would have been obvious to one of ordinary skill in the art at the time of the invention to determine the single RF signal of Boie by evaluating the extent of interference at a given signal frequency and selecting a different frequency when substantial interference is detected as taught by Gerpheide. *See, e.g.*, Gerpheide, col. 8:22-38; Fig. 7.

The combination of Boie with Gerpheide thus presents new, non-cumulative technological teachings related to the elements of claim 18 added by amendment, and such teachings were not considered in the cited art during the '183 Patent prosecution history including the reexamination proceeding. If the original Examiners had known of each of these references, the Examiners likely would have considered them relevant, and likely would have cited them during the respective prosecution/proceeding. Boie in view of Gerpheide therefore raises an SNQ of patentability with respect to independent claim 18.

## **2. Claim 27**

During the first reexamination prosecution, the Patent Owner amended independent claim 27 to recite “a microcontroller using the periodic output signal from the oscillator, the microcontroller selectively providing signal output frequencies to a closely spaced array of input touch terminals of a keypad, the input touch terminals comprising first and second input touch terminals,” and argued that the cited art did not teach or suggest these limitations. After the Patent Owner made this amendment, the Examiner allowed claim 27 stating, “Boie discloses driving the electrodes of electrode array 100 and guard plane 411 with a single RF signal. Boie does not teach or suggest providing signal output frequencies to these components.” *See Ex. B,*



183 Patent File History, Notice of Intent to Issue Ex Parte Reexamination Certificate (Apr. 10, 2013), p. 4.

Gerpheide discloses,

[A reference frequency generator 16] observes position signals to evaluate the extent of interference at some reference frequency. In the event that substantial interference is detected, the generator 16 selects a different frequency for further measurements. The generator 16 seeks to always select a reference frequency away from frequencies which have been found to result in measurement interference, as described below. The generator 16 includes an oscillator 100 which is, for example, set at four MHz, driving a microcontroller 102 and a divide-by-(M+N) circuit 104. Value N is a fixed constant, approximately 50. Value M is specified by the microcontroller 102 to be, for example, one of four values in the range 61 KHz to 80 KHz as specified by the microcontroller 102. The microcontroller 102 performs the functions of interference evaluation 106 and frequency selection 108.

Gerpheide, col. 8:22-38; Fig. 7. Thus, Gerpheide discloses selectively providing signal output frequencies.

It would have been obvious to one of ordinary skill in the art at the time of the invention to determine the single RF signal of Boie by evaluating the extent of interference at a given signal frequency and selecting a different frequency when substantial interference is detected as taught by Gerpheide. *See, e.g.*, Gerpheide, col. 8:22-38; Fig. 7.

Casio discloses first and second input touch terminals. *See, e.g.*, Casio, figure at col. 2, reproduced below. Specifically, the finger drawn 6 in the box in the lower left hand corner includes two black portions illustrating first and second input touch terminals.

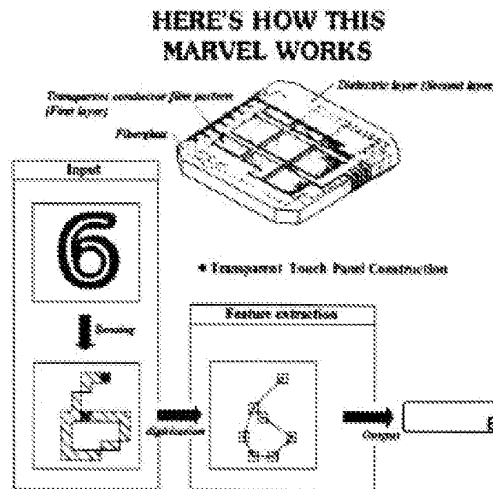

It would have been obvious to one of ordinary skill in the art at the time of the invention to modify the apparatus of Boie to sense first and second input touch terminals (electrodes) as taught by Casio in order to provide finger-stroke or finger-trace recognition capability. *See, e.g.,* Casio, col. 1, fourth paragraph and col. 3, third paragraph; figure (reproduced above).

The combination of Boie with Gerpheide and Casio thus presents new, non-cumulative technological teachings related to the elements of claim 27 added by amendment, and such teachings were not considered in the cited art during the '183 Patent prosecution history including the reexamination proceeding. If the original Examiners had known of each of these references, the Examiners likely would have considered them relevant, and likely would have cited them during the respective prosecution/proceeding. Boie in view of Gerpheide and Casio therefore raises an SNQ of patentability with respect to independent claim 27.

**III. DETAILED EXPLANATION OF THE RELEVANCY AND MANNER OF APPLYING THE PRIOR ART REFERENCES TO EVERY CLAIM FOR WHICH REEXAMINATION IS REQUESTED**

A detailed explanation pointing out the relevance and application of the prior art references to each of claims 18 and 27 is provided below. The charts below indicate what the Patent Owner believes are the portions of the cited art most relevant to the elements of the claims for which reexamination is requested. The Patent Owner, however, reserves the right to take positions asserting and submit arguments explaining why various claim elements are not disclosed or suggested by the cited art.

**A. Claim 18**

`183 Patent Claim Language	Boie in view of Gerpheide
18. A capacitive responsive electronic switching circuit comprising:	“The capacitive sensor of the invention comprises a thin, insulating surface covering a plurality of electrodes. The position of an object, such as a finger or hand-held stylus, with respect to the electrodes, is determined from the centroid of capacitance values measured at the electrodes. . . . The x and y coordinates of the centroid are calculated in a microcontroller from the measured capacitances.” Boie, col. 1:61-col. 2:5, Fig. 4.
an oscillator providing a periodic output signal having a predefined frequency;	“RF oscillator 408 provides an RF signal, for example, 100 kilohertz, to circuits 401, synchronous detector and filter 404 via inverter 410, and guard plane 411.” Boie, col. 3:67-col. 4:2, Fig. 4.
a microcontroller using the periodic output signal from the oscillator, the microcontroller selectively providing signal output frequencies to a plurality of small sized input touch terminals of a keypad;	A reference frequency generator 16 “observes position signals to evaluate the extent of interference at some reference frequency. In the event that substantial interference is detected, the generator 16 selects a different frequency for further measurements. The generator 16 seeks to always select a reference frequency away from frequencies which have been found to result in measurement interference, as described below.

183 Patent Claim Language	Boie in view of Gerpheide
	<p>The generator 16 includes an oscillator 100 which is, for example, set at four MHz, driving a microcontroller 102 and a divide-by-(M+N) circuit 104. Value N is a fixed constant, approximately 50. Value M is specified by the microcontroller 102 to be, for example, one of four values in the range 61 KHz to 80 KHz as specified by the microcontroller 102. The microcontroller 102 performs the functions of interference evaluation 106 and frequency selection 108.” Gerpheide, col. 8:22-38; Fig. 7.</p> <p>“FIG. 2A illustrates the electrodes in a preferred electrode array 12, together with a coordinate axes defining X and Y directions. One embodiment includes sixteen X electrodes and twelve Y electrodes, but for clarity of illustration, only six X electrodes 20 and four Y electrodes 22 are shown. It is apparent to one skilled in the art how to extend the number of electrodes. The array is preferably fabricated as a multilayer printed circuit board 24. The electrodes are etched electrically conductive strips, connected to vias 26 which in turn connect them to other layers in the array. Illustratively, the array 12 is approximately 65 millimeters in the X direction and 49 millimeters in the Y direction. The X electrodes are approximately 0.7 millimeters wide on 3.3 millimeter centers. The Y electrodes are approximately three millimeters wide on 3.3 millimeter centers.” Gerpheide, col. 4:41-55; Fig. 2A.</p> <p>“FIG. 4 shows one embodiment of the synchronous electrode capacitance measurement unit 14 in more detail. The key elements of the synchronous electrode capacitance measurement unit 14 are (a) an element for producing a voltage change in the electrode array synchronously with a reference signal, (b) an element producing a signal indicative of the displacement charge thereby coupled between electrodes of the electrode array, (c) an element</p>

183 Patent Claim Language	Boie in view of Gerpheide
	<p>for demodulating this signal synchronously with the reference signal, and (d) an element for low pass filtering the demodulated signal. Unit 14 is coupled to the electrode array, preferably through a multiplexor or switches.” Gerpheide, col. 5:52-63; Fig. 4.</p> <p>“The reference frequency signal is preferably a digital logic signal from the reference frequency generator 16 (FIG. 1). The reference frequency signal is supplied to unit 14 via an AND gate 72 also having a "drive enable" input, supplied by the reference frequency generator 16 (FIG. 1). The AND gate output feeds through inverter 74 and noninverting buffer 76 to wires RP and RN respectively which are part of a capacitive measurement element 78.” Gerpheide, col. 6:19-26; Fig. 4.</p> <p>“The operational principle of the capacitive position sensor of the invention is shown in FIG. 1. Electrode array 100 is a square or rectangular array of electrodes 101 arranged in a grid pattern of rows and columns, as in an array of tiles. . . . The electrodes are covered with a thin layer of insulating material (not shown). . . . Histogram 110 shows the capacitances for electrodes 101 in array 100 with respect to finger 102.” Boie, col. 2:49-62, Fig. 1.</p> <p>“FIG. 2 shows four such subdivided electrodes in more detail at an intersection of two rows and two columns in array 100. As can be seen from FIG. 2, a horizontal element 201 and a vertical element 202 are situated at each intersection of a row and column.” Boie, col. 3:16-20, Fig. 2.</p> <p>“As will be clear to those skilled in the art, elements 201 and 202 can be fabricated in one plane of a multi-layer printed circuit board together with one set of interconnections, for example, the horizontal row connections 203. The vertical row connections 204 can then be fabricated in another plane of the circuit board</p>

183 Patent Claim Language	Boie in view of Gerpheide
	with appropriate via connections between the planes.” Boie, col. 3:30-36, Fig. 2.
<p>the plurality of small sized input touch terminals defining adjacent areas on a dielectric substrate for an operator to provide inputs by proximity and touch; and</p>	<p>“The operational principle of the capacitive position sensor of the invention is shown in FIG. 1. Electrode array 100 is a square or rectangular array of electrodes 101 arranged in a grid pattern of rows and columns, as in an array of tiles. . . . The electrodes are covered with a thin layer of insulating material (not shown). . . . Histogram 110 shows the capacitances for electrodes 101 in array 100 with respect to finger 102.” Boie, col. 2:49-62, Fig. 1.</p> <p>“FIG. 2 shows four such subdivided electrodes in more detail at an intersection of two rows and two columns in array 100. As can be seen from FIG. 2, a horizontal element 201 and a vertical element 202 are situated at each intersection of a row and column.” Boie, col. 3:16-20, Fig. 2.</p> <p>“As will be clear to those skilled in the art, elements 201 and 202 can be fabricated in one plane of a multi-layer printed circuit board together with one set of interconnections, for example, the horizontal row connections 203. The vertical row connections 204 can then be fabricated in another plane of the circuit board with appropriate via connections between the planes.” Boie, col. 3:30-36, Fig. 2.</p>
<p>a detector circuit coupled to said oscillator for receiving said periodic output signal from said oscillator, and coupled to said input touch terminals, said detector circuit being responsive to signals from said oscillator via said microcontroller and a presence of an operator's body capacitance to ground coupled to said touch terminals when proximal or touched by the operator to provide a control output signal,</p>	<p>“[E]ach row and column of electrodes from array 100 is connected to an integrating amplifier and bootstrap circuit 401, . . . . Each of the outputs from circuits 401 can be selected by multiplexer 402 under control of microcontroller 406. The selected output is then forwarded to summing circuit 403, where such output is combined with a signal from trimmer resistor 409. Synchronous detector and filter 404 convert the output from summing circuit 403 to a signal related to the capacitance of the row or column selected by multiplexer 402. RF oscillator 408 provides an RF signal, for</p>

`183 Patent Claim Language	Boie in view of Gerpheide
	<p>example, 100 kilohertz, to circuits 401, synchronous detector and filter 404 via inverter 410, and guard plane 411.” Boie, col. 3:53-col. 4:2, Fig. 4.</p> <p>“The output of synchronous detector and filter 404 is converted to digital form by analog-to-digital converter 405 and forwarded to microcontroller 406. Thus, microcontroller 406 can obtain a digital value representing the capacitance seen by any row or column of electrode elements (or electrode if measured separately) selected by multiplexer 402. . . . Microcontroller 406 sends data to utilizing means, such as a personal computer (not shown) over lead 420.” Boie, col. 4:21-32, Fig. 4.</p>
<p>wherein said predefined frequency of said oscillator and said signal output frequencies are selected to decrease a first impedance of said dielectric substrate relative to a second impedance of any contaminate that may create an electrical path on said dielectric substrate between said adjacent areas defined by the plurality of small sized input touch terminals, and</p>	<p>“RF oscillator 408 provides an RF signal, for example, 100 kilohertz, to circuits 401, synchronous detector and filter 404 via inverter 410, and guard plane 411.” Boie, col. 3:67-col. 4:2, Fig. 4.</p> <p>“The effects of electrode-to-electrode capacitances, wiring capacitances and other extraneous capacitances are minimized by driving all electrodes and guard plane 411 in unison with the same RF signal from RF oscillator 408.” Boie, col. 4:58-61.</p> <p>“[A] capacitance-based detection device may suffer from electrical background interference from its surroundings, which is coupled onto the sensing electrodes and interferes with position detection. These spurious signals cause troublesome interference with the detection of finger positioning. The device operator may even act as an antenna for electrical interference which may cause a false charge injection or depletion from the detecting electrodes. Accordingly, there is a need for a touch detection system which has the following characteristics: . . . (3) electrical interference signals are rejected and eliminated from the</p>

183 Patent Claim Language	Boie in view of Gerpheide
	<p>detection system regardless of their frequency and without requiring possibly expensive nulling apparatus.” Gerpheide, col. 2:37-57.</p> <p>A reference frequency generator 16 “observes position signals to evaluate the extent of interference at some reference frequency. In the event that substantial interference is detected, the generator 16 selects a different frequency for further measurements. The generator 16 seeks to always select a reference frequency away from frequencies which have been found to result in measurement interference, as described below. The generator 16 includes an oscillator 100 which is, for example, set at four MHz, driving a microcontroller 102 and a divide-by-(M+N) circuit 104. Value N is a fixed constant, approximately 50. Value M is specified by the microcontroller 102 to be, for example, one of four values in the range 61 KHz to 80 KHz as specified by the microcontroller 102. The microcontroller 102 performs the functions of interference evaluation 106 and frequency selection 108.” Gerpheide, col. 8:22-38; Fig. 7.</p>
<p>wherein said detector circuit compares a sensed body capacitance change to ground proximate an input touch terminal to a threshold level to prevent inadvertent generation of the control output signal.</p>	<p>“Referring to FIG. 6, microcomputer 406 reads the initial capacitance values for all the elements in array 100 and stores such values (step 601). Such initial values should reflect the state of array 100 without a finger or other object being nearby, accordingly, it may be desirable to repeat step 601 a number of times and then to select the minimum capacitance values read as the initial values, thereby compensating for the effect of any objects moving close to array 100 during the initialization step. After initialization, all capacitance values are periodically read and the initial values subtracted to yield a remainder value for each element (step 602). If one or more of the remainders exceeds a preset threshold (step 603), indicating that an object is close to or touching array 100, then the x and y coordinates of the centroid of capacitance for such object can be calculated from such</p>



`183 Patent Claim Language	Boie in view of Gerpheide
	remainders (step 604). . . . To avoid spurious operation, it may be desirable to require that two or more measurements exceed the preset threshold. The threshold can be set to some percentage of the range of A/D converter 405, for example 10-15% of such range.” Boie, col. 5:10-48, Fig. 6.

**B. Claim 27**

`183 Patent Claim Language	Boie in view of Gerpheide and Casio
27. A capacitive responsive electronic switching circuit for a controlled keypad device comprising:	<p>“The capacitive sensor of the invention comprises a thin, insulating surface covering a plurality of electrodes. The position of an object, such as a finger or hand-held stylus, with respect to the electrodes, is determined from the centroid of capacitance values measured at the electrodes. . . . The x and y coordinates of the centroid are calculated in a microcontroller from the measured capacitances.” Boie, col. 1:61-col. 2:5, Fig. 4.</p> <p>“A computer input device for use as a computer mouse or keyboard comprises a thin, insulating surface covering an array of electrodes. . . . For applications in which the input device is used as a mouse, the microcontroller forwards position change information to the computer. For applications in which the input device is used as a keyboard, the microcomputer identifies a key from the position of the touching object and forwards such key identity to the computer.” Boie, Abstract.</p>
an oscillator providing a periodic output signal having a predefined frequency;	“RF oscillator 408 provides an RF signal, for example, 100 kilohertz, to circuits 401, synchronous detector and filter 404 via inverter 410, and guard plane 411.” Boie, col. 3:67-col. 4:2, Fig. 4.
a microcontroller using the periodic output signal from the oscillator, the	A reference frequency generator 16 “observes position signals to evaluate the extent of

183 Patent Claim Language	Boie in view of Gerpheide and Casio
<p>microcontroller selectively providing signal output frequencies to a closely spaced array of input touch terminals of a keypad, the input touch terminals comprising first and second input touch terminals;</p>	<p>interference at some reference frequency. In the event that substantial interference is detected, the generator 16 selects a different frequency for further measurements. The generator 16 seeks to always select a reference frequency away from frequencies which have been found to result in measurement interference, as described below. The generator 16 includes an oscillator 100 which is, for example, set at four MHz, driving a microcontroller 102 and a divide-by-(M+N) circuit 104. Value N is a fixed constant, approximately 50. Value M is specified by the microcontroller 102 to be, for example, one of four values in the range 61 KHz to 80 KHz as specified by the microcontroller 102. The microcontroller 102 performs the functions of interference evaluation 106 and frequency selection 108.” Gerpheide, col. 8:22-38; Fig. 7.</p> <p>“FIG. 2A illustrates the electrodes in a preferred electrode array 12, together with a coordinate axes defining X and Y directions. One embodiment includes sixteen X electrodes and twelve Y electrodes, but for clarity of illustration, only six X electrodes 20 and four Y electrodes 22 are shown. It is apparent to one skilled in the art how to extend the number of electrodes. The array is preferably fabricated as a multilayer printed circuit board 24. The electrodes are etched electrically conductive strips, connected to vias 26 which in turn connect them to other layers in the array. Illustratively, the array 12 is approximately 65 millimeters in the X direction and 49 millimeters in the Y direction. The X electrodes are approximately 0.7 millimeters wide on 3.3 millimeter centers. The Y electrodes are approximately three millimeters wide on 3.3 millimeter centers.” Gerpheide, col. 4:41-55; Fig. 2A.</p> <p>“FIG. 4 shows one embodiment of the synchronous electrode capacitance measurement unit 14 in more detail. The key elements of the</p>

183 Patent Claim Language	Boie in view of Gerpheide and Casio
	<p>synchronous electrode capacitance measurement unit 14 are (a) an element for producing a voltage change in the electrode array synchronously with a reference signal, (b) an element producing a signal indicative of the displacement charge thereby coupled between electrodes of the electrode array, (c) an element for demodulating this signal synchronously with the reference signal, and (d) an element for low pass filtering the demodulated signal. Unit 14 is coupled to the electrode array, preferably through a multiplexor or switches.” Gerpheide, col. 5:52-63; Fig. 4.</p> <p>“The reference frequency signal is preferably a digital logic signal from the reference frequency generator 16 (FIG. 1). The reference frequency signal is supplied to unit 14 via an AND gate 72 also having a "drive enable" input, supplied by the reference frequency generator 16 (FIG. 1). The AND gate output feeds through inverter 74 and noninverting buffer 76 to wires RP and RN respectively which are part of a capacitive measurement element 78.” Gerpheide, col. 6:19-26; Fig. 4.</p> <p>“The operational principle of the capacitive position sensor of the invention is shown in FIG. 1. Electrode array 100 is a square or rectangular array of electrodes 101 arranged in a grid pattern of rows and columns, as in an array of tiles. . . . The electrodes are covered with a thin layer of insulating material (not shown). . . . Histogram 110 shows the capacitances for electrodes 101 in array 100 with respect to finger 102.” Boie, col. 2:49-62, Fig. 1.</p> <p>“FIG. 2 shows four such subdivided electrodes in more detail at an intersection of two rows and two columns in array 100. As can be seen from FIG. 2, a horizontal element 201 and a vertical element 202 are situated at each intersection of a row and column.” Boie, col. 3:16-20, Fig. 2.</p>

183 Patent Claim Language	Boie in view of Gerpheide and Casio
	<p>“As will be clear to those skilled in the art, elements 201 and 202 can be fabricated in one plane of a multi-layer printed circuit board together with one set of interconnections, for example, the horizontal row connections 203. The vertical row connections 204 can then be fabricated in another plane of the circuit board with appropriate via connections between the planes.” Boie, col. 3:30-36, Fig. 2.</p>
<p>the first and second input touch terminals defining areas for an operator to provide an input by proximity and touch; and</p>	<p>“The operational principle of the capacitive position sensor of the invention is shown in FIG. 1. Electrode array 100 is a square or rectangular array of electrodes 101 arranged in a grid pattern of rows and columns, as in an array of tiles. . . . The electrodes are covered with a thin layer of insulating material (not shown). . . . Histogram 110 shows the capacitances for electrodes 101 in array 100 with respect to finger 102.” Boie, col. 2:49-62, Fig. 1.</p> <p>“FIG. 2 shows four such subdivided electrodes in more detail at an intersection of two rows and two columns in array 100. As can be seen from FIG. 2, a horizontal element 201 and a vertical element 202 are situated at each intersection of a row and column.” Boie, col. 3:16-20, Fig. 2.</p> <p>“As will be clear to those skilled in the art, elements 201 and 202 can be fabricated in one plane of a multi-layer printed circuit board together with one set of interconnections, for example, the horizontal row connections 203. The vertical row connections 204 can then be fabricated in another plane of the circuit board with appropriate via connections between the planes.” Boie, col. 3:30-36, Fig. 2.</p>

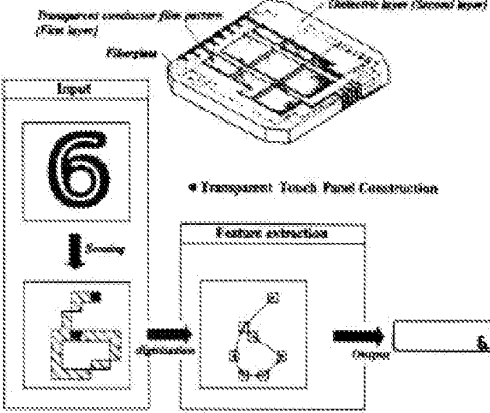
183 Patent Claim Language	Boie in view of Gerpheide and Casio
	<p style="text-align: center;"><b>HERE'S HOW THIS MARVEL WORKS</b></p>  <p style="text-align: center;">Casio, col. 2.</p>
<p>a detector circuit coupled to said oscillator for receiving said periodic output signal from said oscillator, and coupled to said first and second touch terminals, said detector circuit being responsive to signals from said oscillator via said microcontroller and a presence of an operator's body capacitance to ground coupled to said first and second touch terminals when proximal or touched by the operator to provide a control output signal for actuation of the controlled keypad device,</p>	<p>“[E]ach row and column of electrodes from array 100 is connected to an integrating amplifier and bootstrap circuit 401, .... Each of the outputs from circuits 401 can be selected by multiplexer 402 under control of microcontroller 406. The selected output is then forwarded to summing circuit 403, where such output is combined with a signal from trimmer resistor 409. Synchronous detector and filter 404 convert the output from summing circuit 403 to a signal related to the capacitance of the row or column selected by multiplexer 402. RF oscillator 408 provides an RF signal, for example, 100 kilohertz, to circuits 401, synchronous detector and filter 404 via inverter 410, and guard plane 411.” Boie, col. 3:53-col. 4:2, Fig. 4.</p> <p>“The output of synchronous detector and filter 404 is converted to digital form by analog-to-digital converter 405 and forwarded to microcontroller 406. Thus, microcontroller 406 can obtain a digital value representing the capacitance seen by any row or column of electrode elements (or electrode if measured separately) selected by multiplexer 402. . . . Microcontroller 406 sends data to utilizing means, such as a personal computer (not shown)</p>

183 Patent Claim Language	Boie in view of Gerpheide and Casio
	<p>over lead 420.” Boie, col. 4:21-32, Fig. 4.</p> <p>“A computer input device for use as a computer mouse or keyboard comprises a thin, insulating surface covering an array of electrodes. . . . For applications in which the input device is used as a mouse, the microcontroller forwards position change information to the computer. For applications in which the input device is used as a keyboard, the microcomputer identifies a key from the position of the touching object and forwards such key identity to the computer.” Boie, Abstract.</p> <div data-bbox="787 798 1282 1281" data-label="Diagram"> <p>The diagram is titled "HERE'S HOW THIS MARVEL WORKS". It shows a 3D perspective view of a touch panel with two layers: a "Transparent conductive film pattern (First layer)" and a "Dielectric layer (Second layer)". A "Fingerprint" is shown being touched on the surface. Below this is a flowchart labeled "Transparent Touch Panel Construction". The flowchart starts with an "Input" box containing a digit "6". An arrow points down to a "Feature extraction" box, which shows the digit "6" with various points and lines indicating its structure. Another arrow points right to an "Output" box containing a digit "6".</p> </div> <p>Casio, col. 2.</p>
<p>said detector circuit being configured to generate said control output signal when the operator is proximal or touches said second touch terminal after the operator is proximal or touches said first touch terminal.</p>	<p>“In using the position sensor of the invention as a computer mouse or trackball to control a cursor, movement of the mouse or trackball is emulated by touching array 100 with finger 102, or some other object, and stroking finger 102 over array 100 to move the cursor. Changes in position of the finger with respect to array 100 are reflected in corresponding changes in position of the cursor. Thus, for such an application, microcontroller 406 sends data over lead 420 relating to changes in position. FIG. 6 is a flow chart of the operation of microcontroller 406 in such an application.” Boie, col. 4:67-col. 5:9, Fig. 6.</p>

183 Patent Claim Language	Boie in view of Gerpheide and Casio
	<p style="text-align: center;"><b>HERE'S HOW THIS MARVEL WORKS</b></p> <p style="text-align: center;">Casio, col. 2.</p>

**IV. CONCLUSION**

A substantial new question of patentability is raised based on the newly cited prior art combinations, and therefore a reexamination of claims 18 and 27 is warranted. Again, the Patent Owner reserves the right to take positions asserting and to submit arguments explaining why various claim elements are not disclosed or suggested by the cited art.

If the Office should have any questions, please contact the undersigned attorney. The Commissioner is hereby authorized to charge any fees due in connection with this filing, or credit any overpayment, to Deposit Account No. 50-1065.

Respectfully submitted,

December 24, 2013  
Date

/Brian A. Carlson/  
Brian A. Carlson  
Reg. No. 37,793

Slater & Matsil, L.L.P.  
17950 Preston Rd.  
Suite 1000  
Dallas, TX 75252  
972-732-1001  
972-732-9218 (fax)



# EXHIBIT A

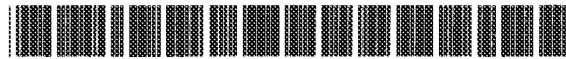

US005796183A

# United States Patent [19] Hourmand

[11] Patent Number: **5,796,183**  
[45] Date of Patent: **Aug. 18, 1998**

[54] CAPACITIVE RESPONSIVE ELECTRONIC SWITCHING CIRCUIT

[75] Inventor: Byron Hourmand, Hersey, Mich.

[73] Assignee: Nartron Corporation, Reed City, Mich.

[21] Appl. No.: 601,268

[22] Filed: Jan. 31, 1996

[51] Int. Cl.<sup>6</sup> H01H 35/00

[52] U.S. Cl. 307/116; 361/181; 307/125; 307/139

[58] Field of Search 307/112, 113, 307/116, 125, 139, 140, 157; 361/181

### [56] References Cited

#### U.S. PATENT DOCUMENTS

3,549,909	12/1970	Adelson et al.	
3,641,410	2/1972	Vogelsberg	
3,651,391	3/1972	Vogelsberg	
3,666,988	5/1972	Bellis	
3,798,370	3/1974	Hurst	
3,879,618	4/1975	Larson	307/116
3,899,713	8/1975	Barkan et al.	
3,911,215	10/1975	Hurst et al.	
3,919,596	11/1975	Bellis	
3,965,465	6/1976	Alexander	
3,984,757	10/1976	Gott et al.	
4,016,453	4/1977	Moennig	
4,031,408	6/1977	Holz	
4,071,689	1/1978	Talmage et al.	
4,101,805	7/1978	Stone	
4,119,864	10/1978	Petrizio	
4,152,629	5/1979	Raupp	
4,159,473	6/1979	Senk	
4,210,822	7/1980	Wern	
4,211,959	7/1980	Deavenport et al.	
4,213,061	7/1980	Conner	
4,220,815	9/1980	Gibson et al.	
4,237,421	12/1980	Waldron	
4,246,533	1/1981	Chiang	
4,257,117	3/1981	Besson	
4,264,831	4/1981	Wern	
4,289,972	9/1981	Wern	
4,289,980	9/1981	McLaughlin	

4,308,443	12/1981	Tucker et al.	
4,323,829	4/1982	Witney et al.	
4,352,141	9/1982	Kent	363/181
4,360,737	11/1982	Leopold	
4,374,381	2/1983	Ng et al.	
4,476,463	10/1984	Ng et al.	
4,503,294	3/1985	Matsumaru	200/5 A
4,731,548	3/1988	Ingraham	
4,758,735	7/1988	Ingraham	
4,831,279	5/1989	Ingraham	
4,910,504	3/1990	Eriksson	
4,939,382	7/1990	Gruodis	
4,942,631	7/1990	Rosa	4/623
5,012,124	4/1991	Hollaway	
5,066,898	11/1991	Miller et al.	
5,087,825	2/1992	Ingraham	
5,208,516	5/1993	Saidian	
5,233,231	8/1993	Wieth et al.	
5,235,217	8/1993	Kirtou	307/326
5,386,219	1/1995	Greanias et al.	
5,453,644	9/1995	Yap et al.	
5,572,205	11/1996	Caldwell et al.	341/33

Primary Examiner—William M. Shoop, Jr.  
Assistant Examiner—Jonathan Kaplan  
Attorney, Agent, or Firm—Price, Heneveld, Cooper, DeWitt & Litton

### [57] ABSTRACT

A capacitive responsive electronic switching circuit comprises an oscillator providing a periodic output signal having a frequency of 50 kHz or greater, an input touch terminal defining an area for an operator provide an input by proximity and touch, and a detector circuit coupled to the oscillator for receiving the periodic output signal from the oscillator, and coupled to the input touch terminal. The detector circuit being responsive to signals from the oscillator and the presence of an operator's body capacitance to ground coupled to the touch terminal when in proximity or touched by an operator to provide a control output signal. Preferably, the oscillator provides a periodic output signal having a frequency of 800 kHz or greater. An array of touch terminals may be provided in close proximity due to the reduction in crosstalk that may result from contaminants by utilizing an oscillator outputting a signal having a frequency of 50 kHz or greater.

32 Claims, 13 Drawing Sheets

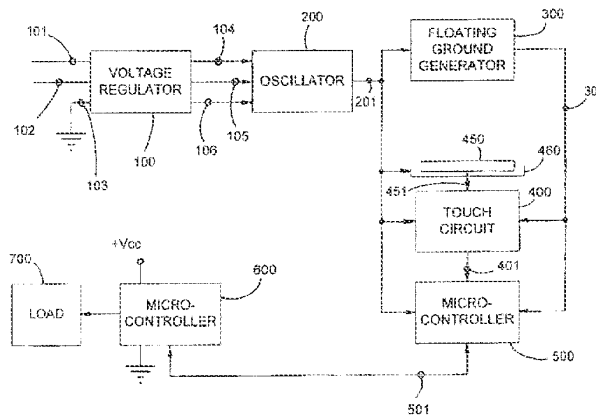

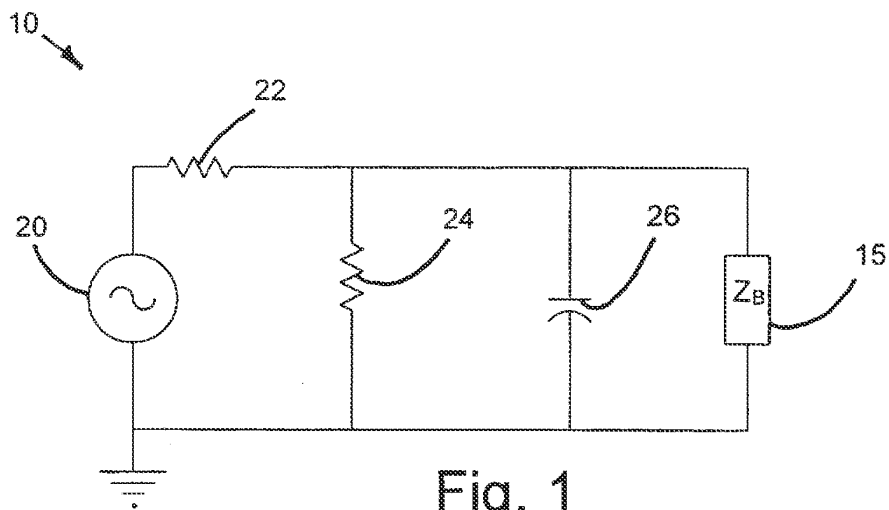

Fig. 1

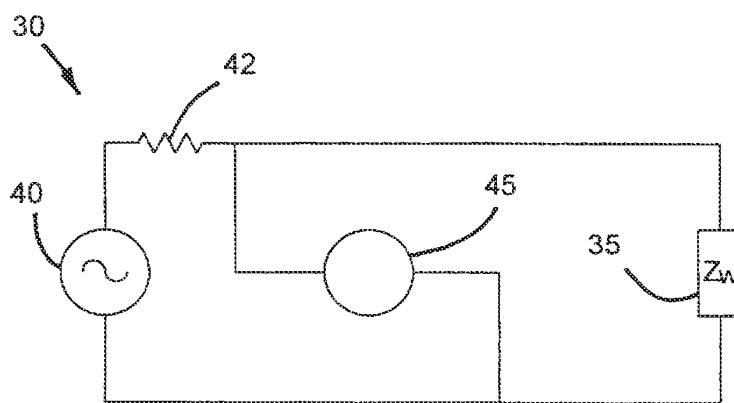

Fig. 2

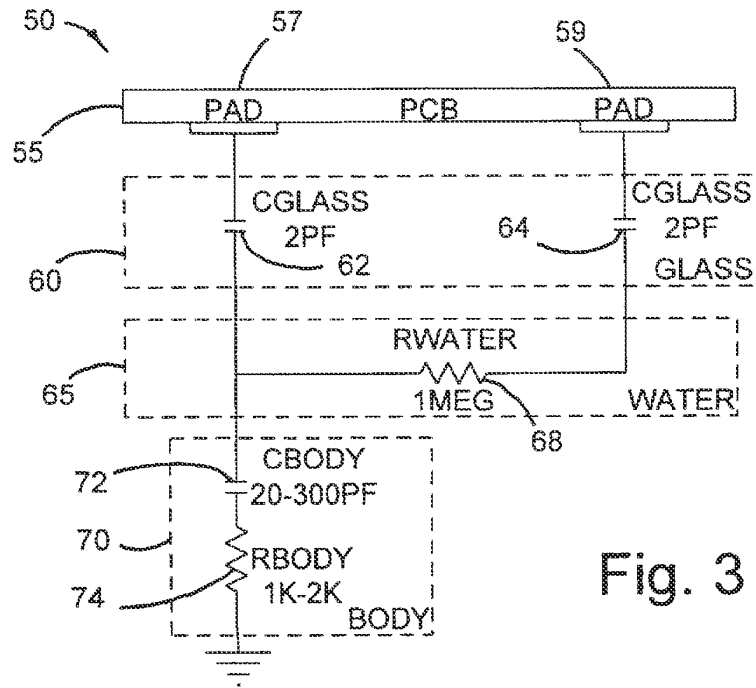

Fig. 3

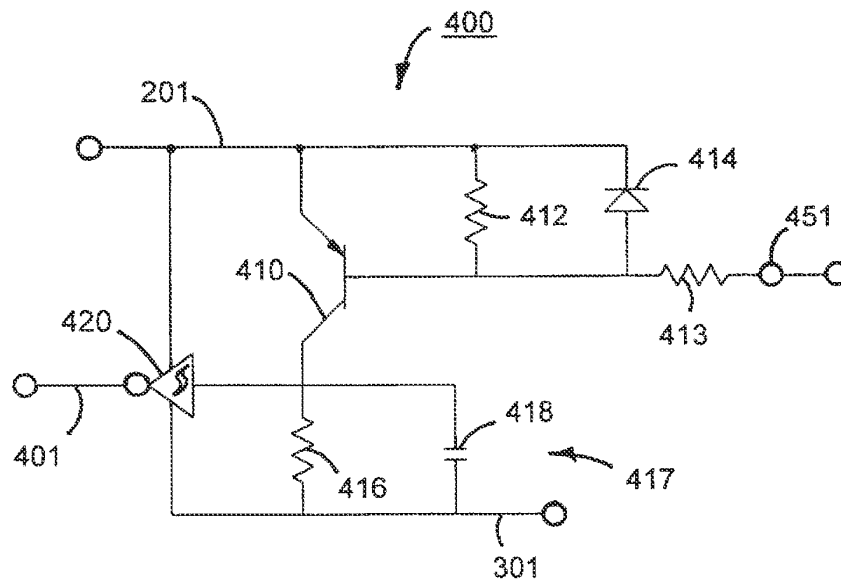

Fig. 8

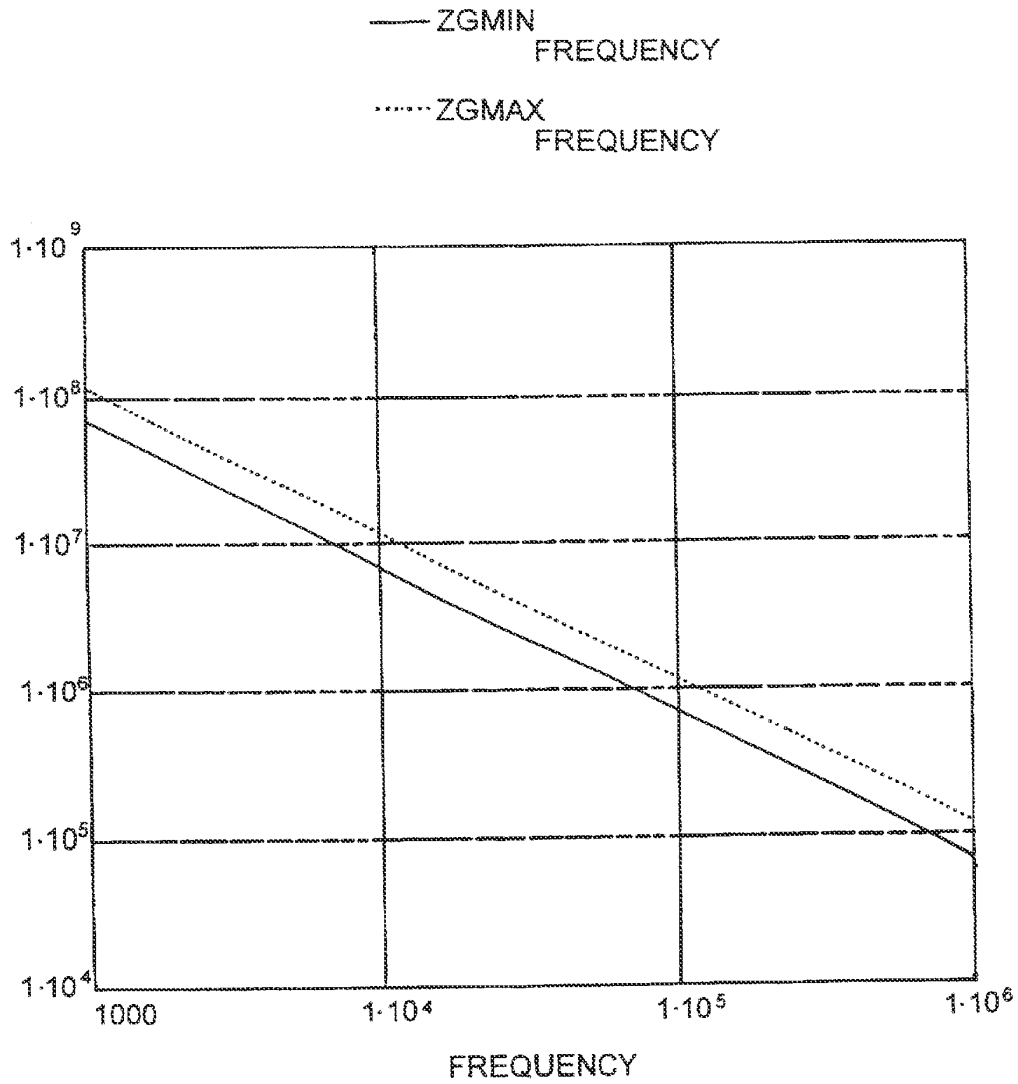

Fig. 3A

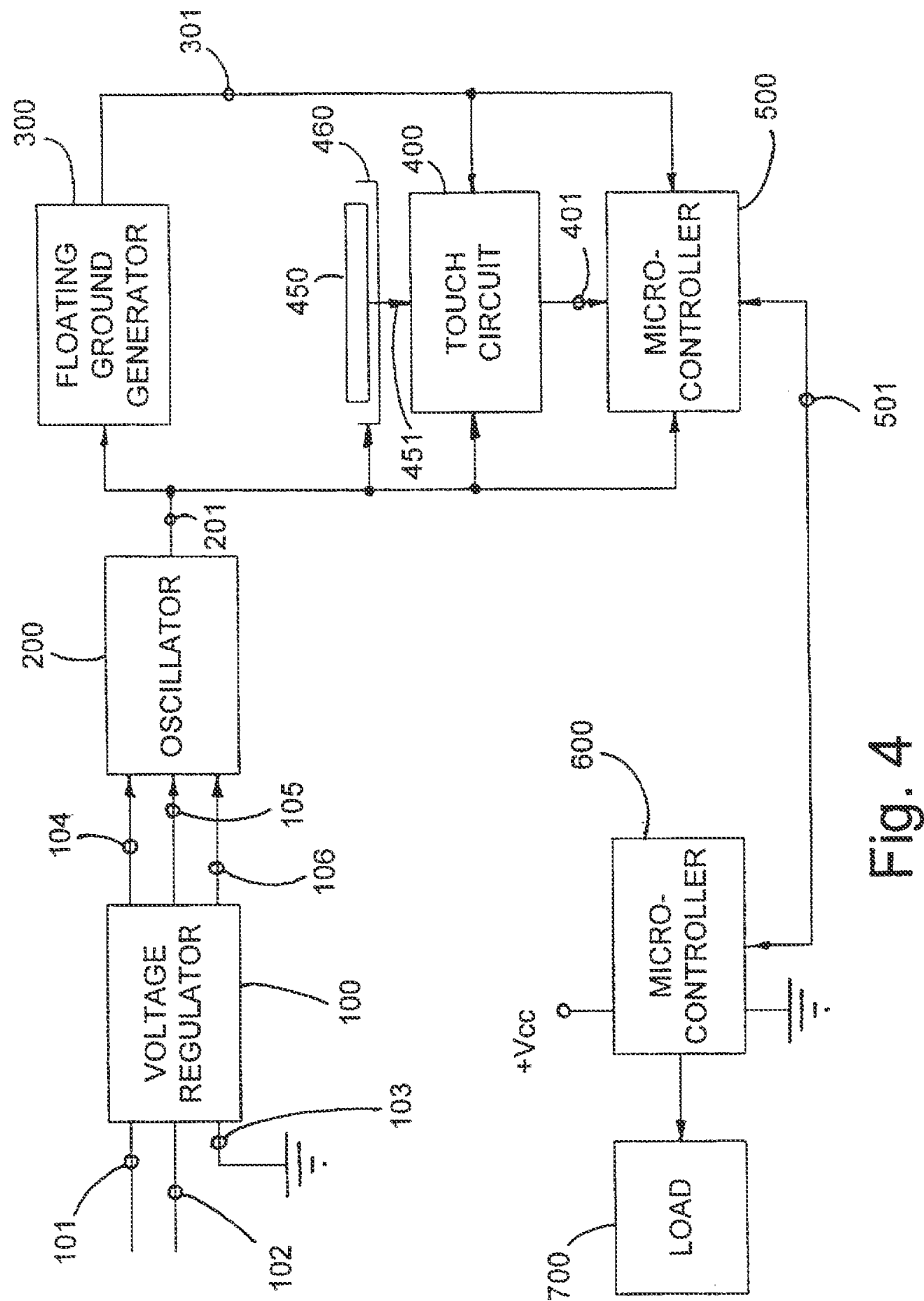
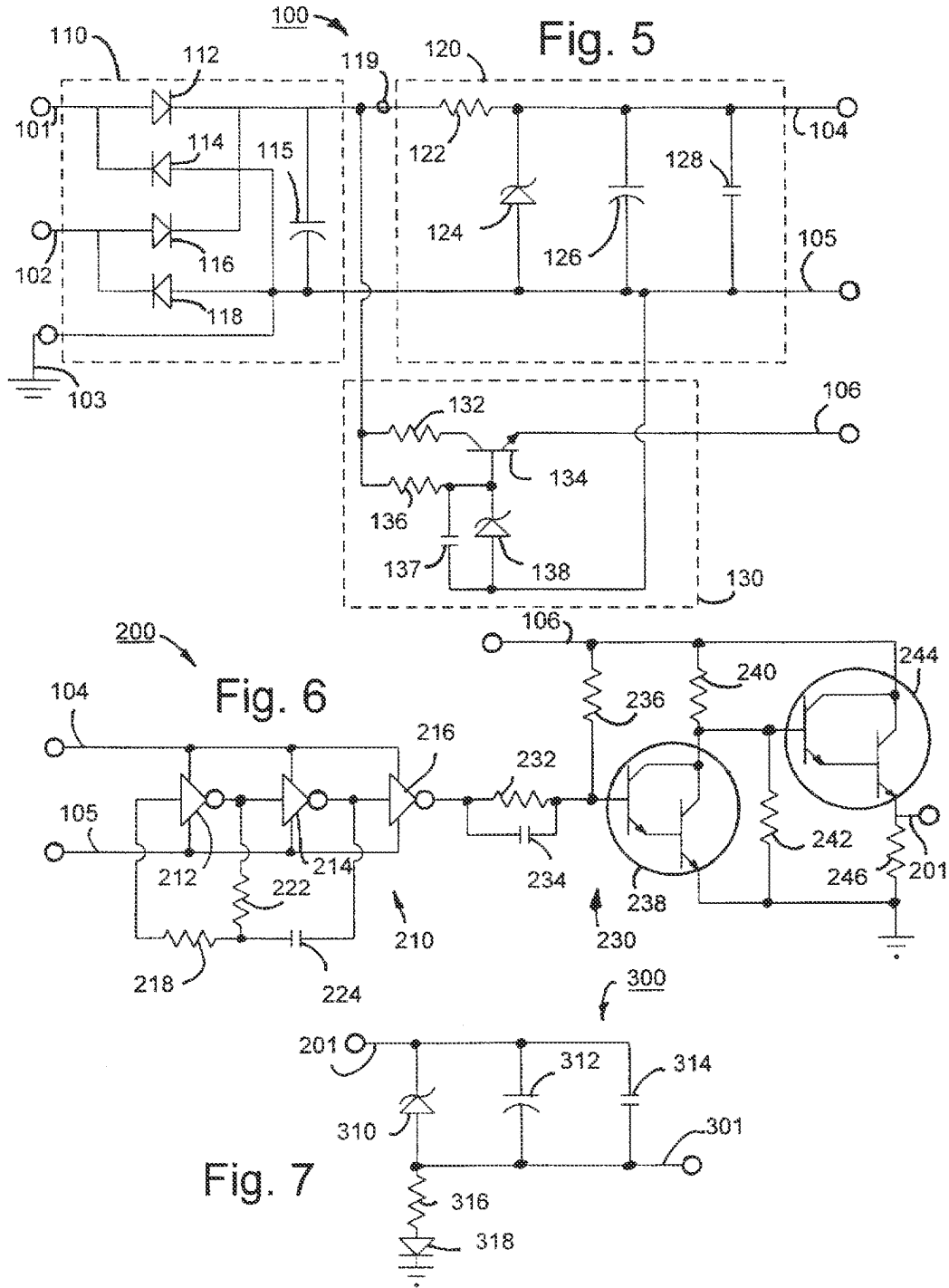

Fig. 4



S/N VS. BODY CAPACITANCE  
TEMPERATURE = 105°C

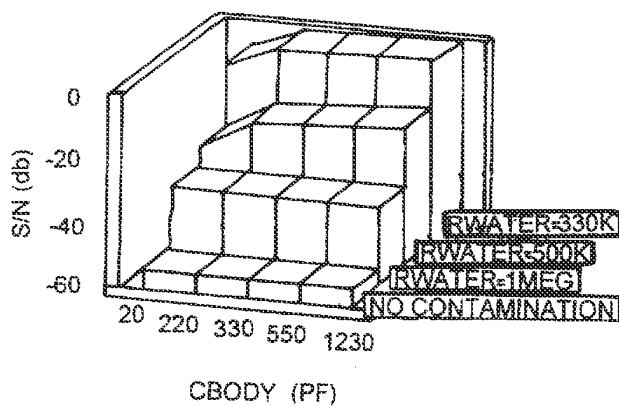

Fig. 9

S/N VS. BODY CAPACITANCE  
TEMPERATURE = 25°C

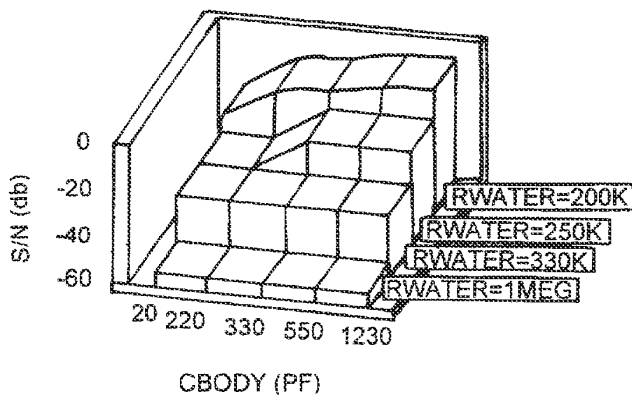

Fig. 10



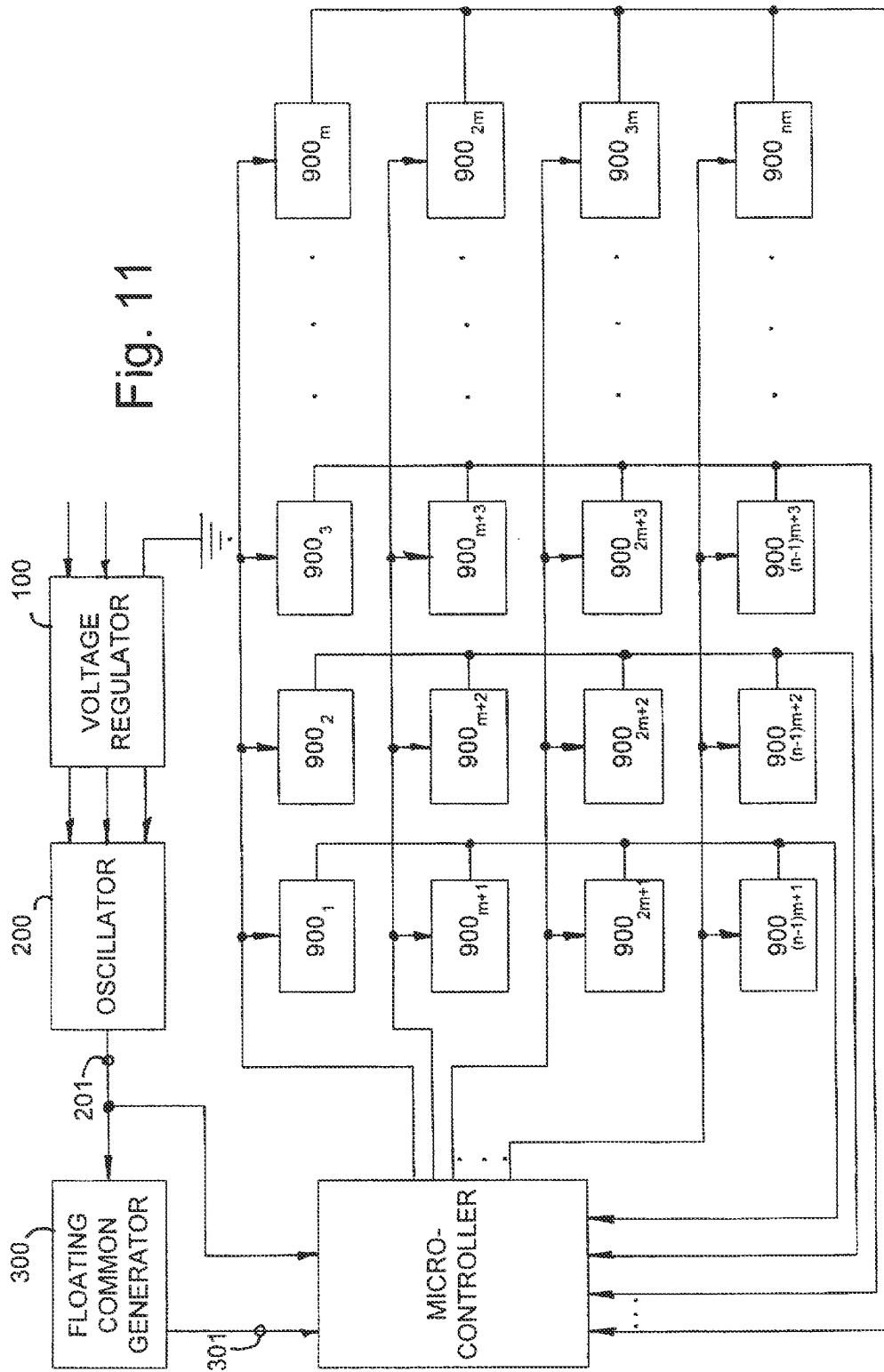

Fig. 11

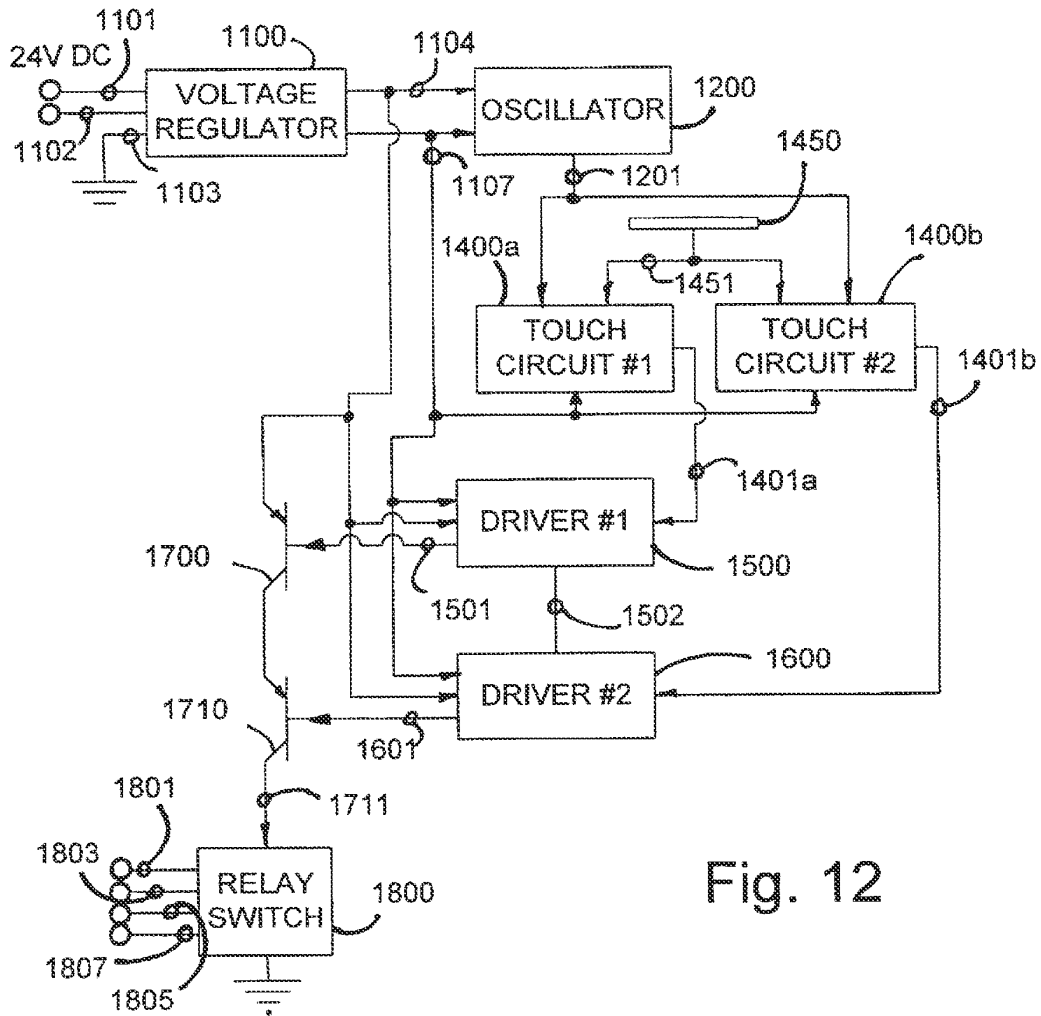

Fig. 12

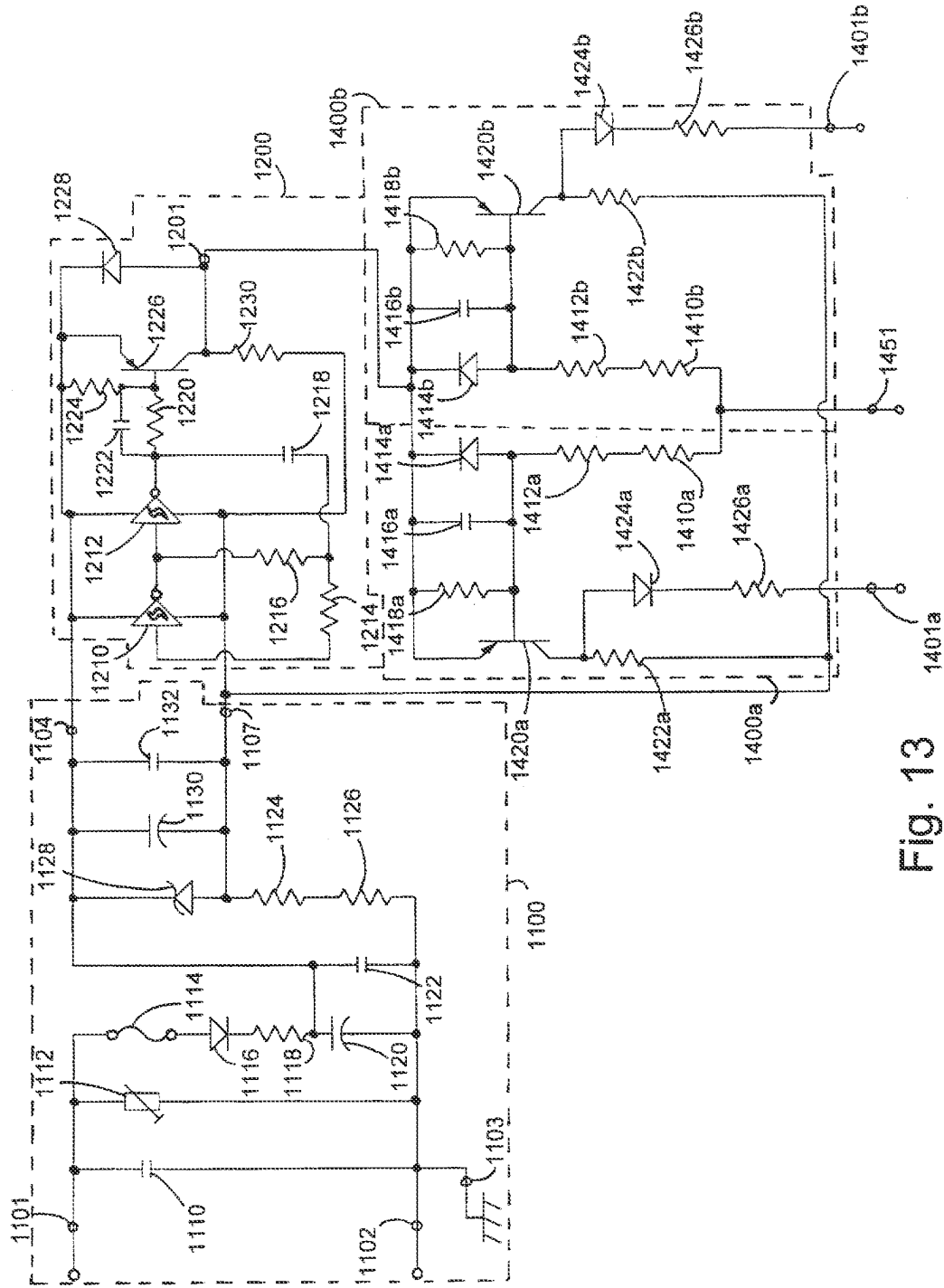

Fig. 13

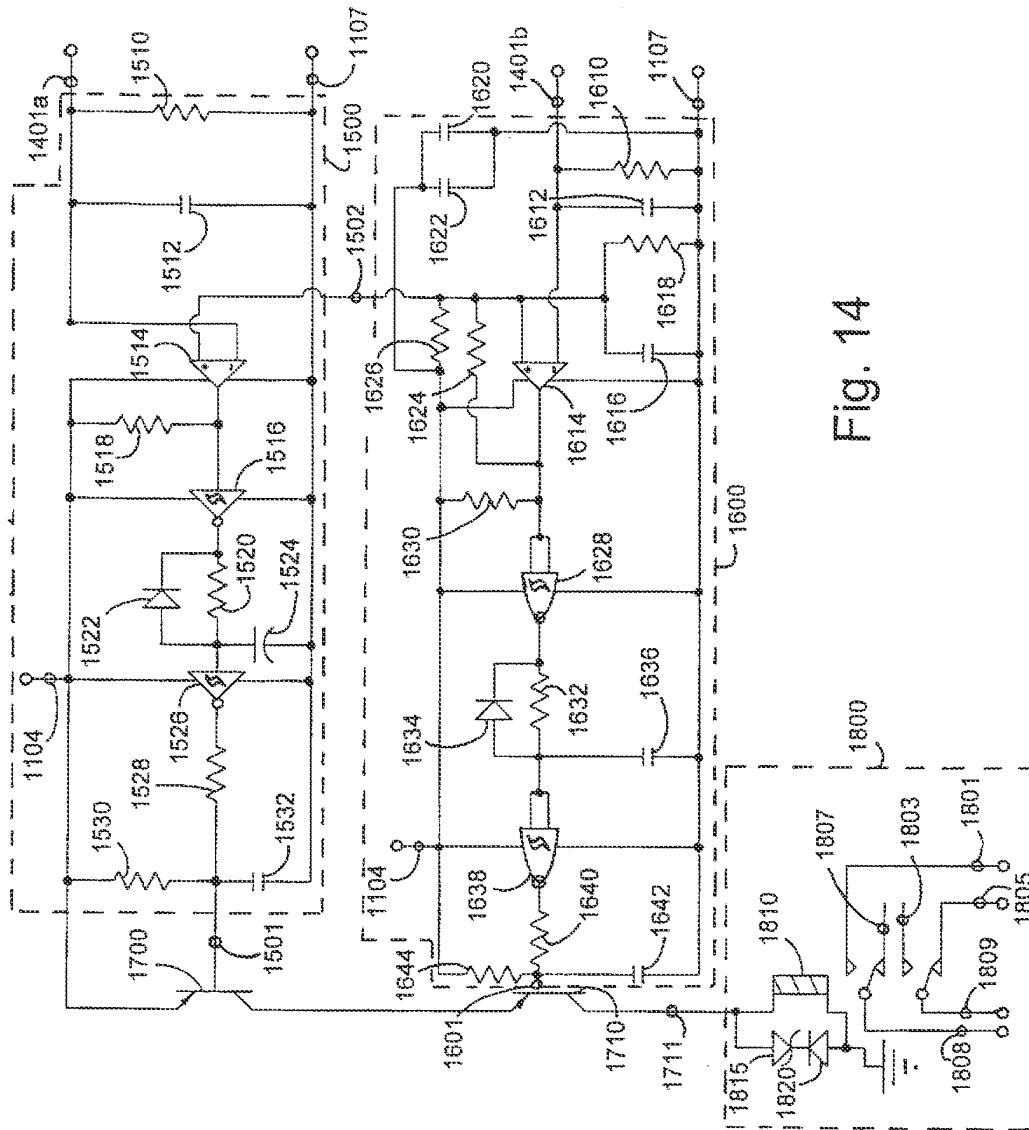

Fig. 14

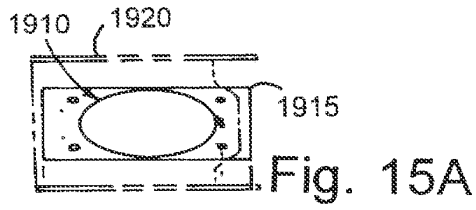

Fig. 15A

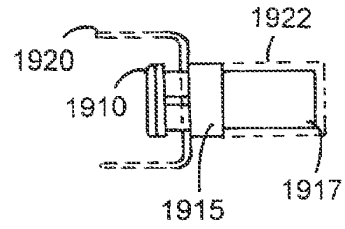

Fig. 15B

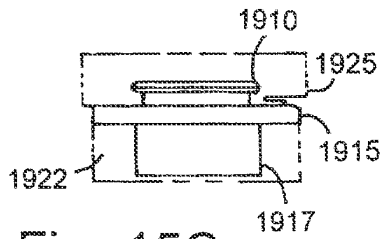

Fig. 15C

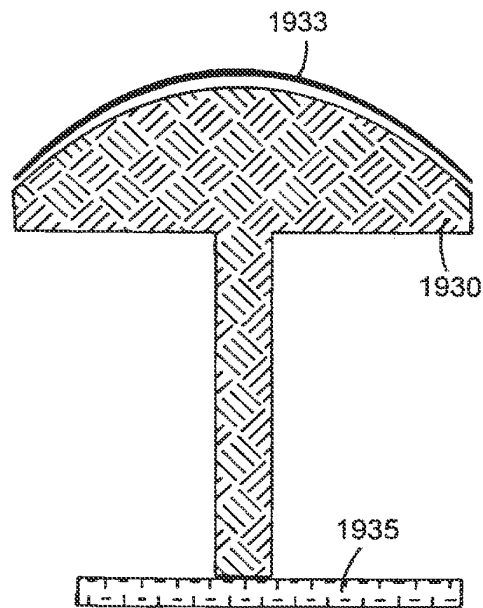

Fig. 16

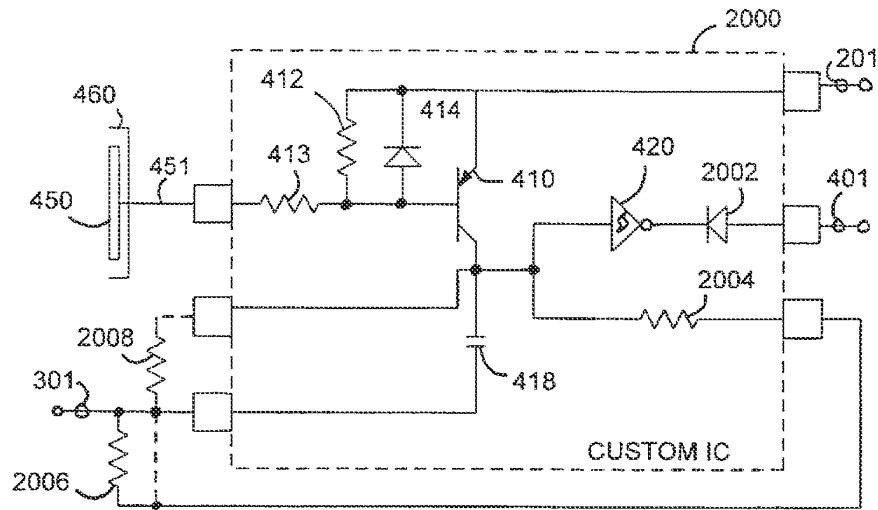

Fig. 17

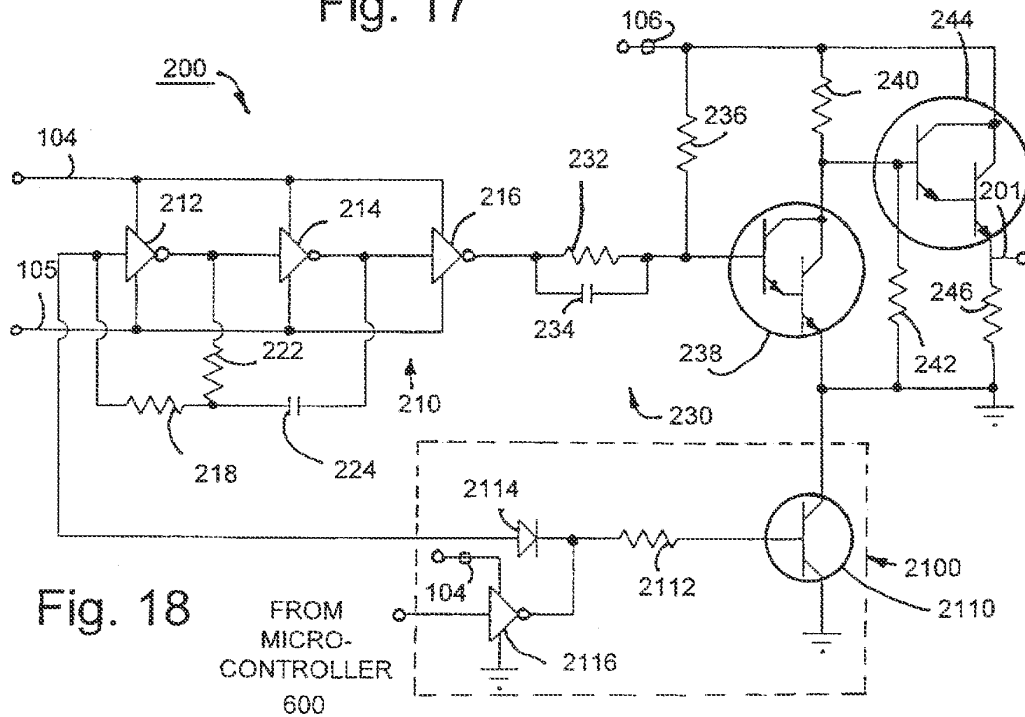
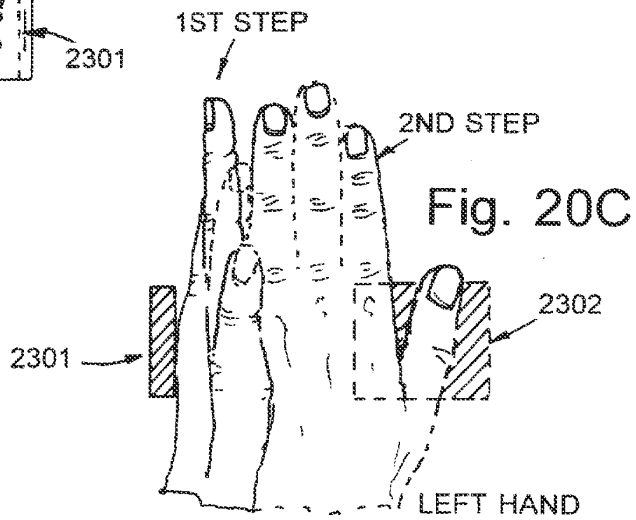
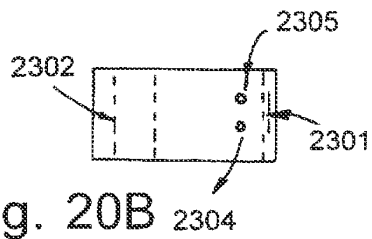
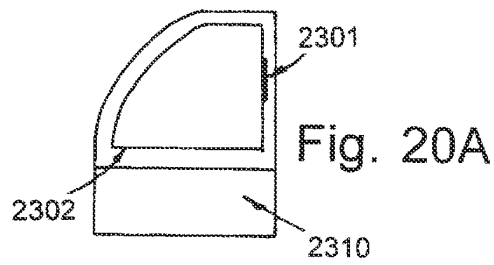
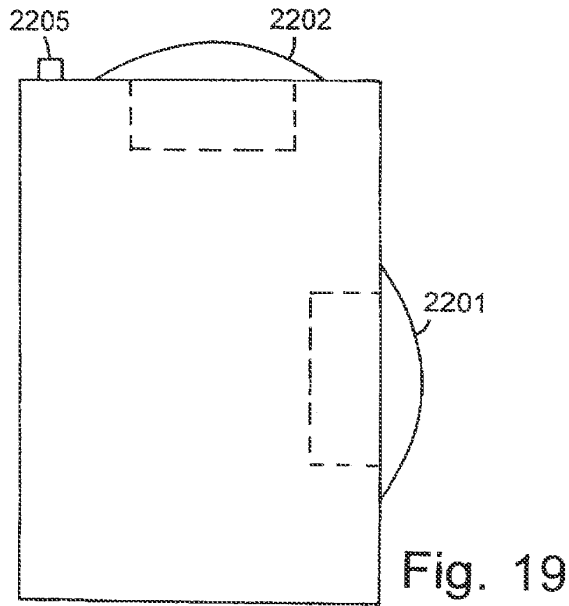

Fig. 18



## CAPACITIVE RESPONSIVE ELECTRONIC SWITCHING CIRCUIT

### BACKGROUND OF THE INVENTION

The present invention relates to an electrical circuit and particularly a capacitive responsive electronic switching circuit used to make possible a "zero force" manual electronic switch.

Manual switches are well known in the art existing in the familiar forms of the common toggle light switch, pull cord switches, push button switches, and keyboard switches among others. The majority of such switches employ a mechanical contact that "makes" and "breaks" the circuit to be switched as the switch is moved to a closed or an open condition.

Switches that operate by a mechanical contact have a number of well known problems. First, mechanical movements of components within any mechanism make those components susceptible to wear, fatigue, and loosening. This is a progressive problem that occurs with use and leads to eventual failure when a sufficient amount of movement has occurred.

Second, a sudden "make" or "break" between conductive contacts typically produces an electrical arc as the contacts come into close proximity. This arcing action generates both radio frequency emissions and high frequency noise on the line that is switched.

Third, the separation between contacts that occurs on each break, exposes the contact surfaces to corrosion and contamination. A particular problem occurs when the arc associated with a "make" or "break" occurs in an oxidizing atmosphere. The heat of the arc in the presence of oxygen facilitates the formation of oxides on the contact surfaces. Once exposed, the contact surfaces of mechanical switches are also vulnerable to contaminants. Water borne contaminants such as oils and salts can be a particular problem on the contact surfaces of switches. A related problem occurs in that the repeated arcing of mechanical contact can result in a migration of contact materials away from the area of the mechanical contact. Corrosion, contamination, and migration operating independently or in combination often lead to eventual switch failure where the switch seizes in a closed or opened condition.

An additional problem results from the mechanical force required in operating a mechanical switch. This problem occurs in systems where a human operator is required to repetitively operate a given switch or a number of switches. Such repetitive motions commonly occur in the operation of electronic keyboards such as those used with computers and in industrial switches such as used in forming and assembly equipment among other applications. A common type of industrial switch is the palm button seen in pressing and insertion equipment. For safety purposes, the operator must press the switch before an insertion or pressing can occur. This ensures that the operator's hand(s) is(are) on the button(s) and not in the field of motion of the associated machinery. It also ensures that the mechanical motion occurs at a desired and controllable point in time. The difficulty arises from the motion and force required of the operator. In recent years, it has been noted that repeated human motions can result in debilitating and painful wear on joints and soft tissues yielding arthritis like symptoms. Such repetitive motion may result in swelling and cramping in muscle tissues associated with conditions such as Carpal Tunnel Syndrome. Equipment designers combat these Repetitive Motion or Cumu-

lative Trauma Disorders by adopting ergonomic designs that more favorably control the range, angle, number, and force of motions required of an operator as well as the number of the operator's muscle groups involved in the required motions. Prosthetics and tests are used as well to provide strain relief for the operator's muscles, joints, and tendons.

In mechanical switches, the force required to actuate the switch may be minimized by reducing spring forces and frictional forces between moving parts. However, reducing such forces makes such switches more vulnerable to failure. For instance, weaker springs typically lower the pressure between contacts in a "make" condition. This lower contact pressure increases the resistance in the switch which can lead to fatal heating in the switch and/or loss of voltage applied to the switched load. Reducing frictional forces in the switch by increasing the use of lubricants is undesirable because the lubricants can migrate and contaminate the contact surfaces. A switch designer may also reduce friction by providing looser fits between moving parts. However, looser fits tend to increase wear and contribute to earlier switch failure. A designer can also reduce friction by using higher quality, higher cost, surface finishes on the parts. Thus, as apparent from the foregoing description, measures taken to reduce actuator force in mechanical switch parts generally reduce the reliability and performance of the switch and/or increase the cost of the switch.

In applications such as computer keyboards or appliance controls, the electric load switched by a given switch can be quite low in terms of current and/or voltage. In such cases it is possible to use low force membrane switches such as described in U.S. Pat. No. 4,503,294. Such switches can relieve operator strain and are not as susceptible to arcing problems because they switch small loads. However, the flexible membrane remains susceptible to wear, corrosion, and contamination. Although such switches require very low actuation force, they are still mechanically based and thus suffer from the same problems as any other mechanical switch.

A more recent innovation is the development of "zero force" touch switches. These switches have no moving parts and no contact surfaces that directly switch loads. Rather, these switches operate by detecting the operator's touch and then use solid state electronics to switch the loads or activate mechanical relays or triacs to switch even larger loads. Approaches include optical proximity or motion detectors to detect the presence or motion of a body part such as in the automatic controls used in urinals in some public rest rooms or as disclosed in U.S. Pat. No. 4,942,631. Although these non-contact switches are by their very nature truly zero force, they are not practical where a multiplicity of switches are required in a small area such as a keyboard. Among other problems, these non-contact switches suffer from the comparatively high cost of electro-optics and from false detections when the operator's hand or other body part unintentionally comes close to the switch's area of detection. Some optical touch keyboards have been proposed, but none have enjoyed commercial success due to performance and/or cost considerations.

A further solution has been to detect the operator's touch via the electrical conductivity of the operator's skin. Such a system is described in U.S. Pat. No. 3,879,618. Problems with this system result from variations in the electrical conductivity of different operators due to variations in sweat, skin oils, or dryness, and from variable ambient conditions such as humidity. A further problem arises in that the touch surface of the switch that the operator touches must remain clean enough to provide an electrical conductivity path to



the operator. Such surfaces can be susceptible to contamination, corrosion, and/or a wearing away of the conductive material. Also, these switches do not work if the operator is wearing a glove. Safety considerations also arise by virtue of the operators placing their body in electrical contact with the switch electronics. A further problem arises in that such systems are vulnerable to contact with materials that are equally or more conductive than human skin. For instance, water condensation can provide a conductive path as good as that of an operator's skin, resulting in a false activation.

A common solution used to achieve a zero force touch switch has been to make use of the capacitance of the human operator. Such switches, which are hereinafter referred to as capacitive touch switches, utilize one of at least three different methodologies. The first method involves detecting RF or other high frequency noise that a human operator can capacitively couple to a touch terminal when the operator makes contact such as is disclosed in U.S. Pat. No. 5,066,898. One common source of noise is 60 Hz noise radiated from commercial power lines. A drawback of this approach is that radiated electrical noise can vary in intensity from locale to locale and thereby cause variations in switch sensitivity. In some cases, devices implemented using this first method, rely on conductive contact between the operator and the touch terminal of the switch. As stated, such surfaces are subject to contamination, corrosion, and wear and will not work with gloved hands. An additional problem can arise in the presence of moisture when multiple switches are employed in a dense array such as a keyboard. In such instances, the operator may touch one touch terminal, but end up inadvertently activating others through the path of conduction caused by the moisture contamination.

A second method for implementing capacitive touch switches is to couple the capacitance of the operator into a variable oscillator circuit that outputs a signal having a frequency that varies with the capacitance seen at a touch terminal. An example of such a system is described in U.S. Pat. No. 5,235,217. Problems with such a system can arise where conductive contact with the operator is required and where the frequency change caused by a touch is close to the frequency changes that would result from unintentionally coming into contact with the touch terminal.

Another method for implementing capacitive touch switches relies on the change in capacitive coupling between a touch terminal and ground. Systems utilizing such a method are described in U.S. Pat. No. 4,758,735 and U.S. Pat. No. 5,087,825. With this methodology the detection circuit consists of an oscillator (or AC line voltage derivative) providing a signal to a touch terminal whose voltage is then monitored by a detector. The touch terminal is driven in electrical series with other components that function in part as a charge pump. The touch of an operator then provides a capacitive short to ground via the operator's own body capacitance that lowers the amplitude of oscillator voltage seen at the touch terminal. A major advantage of this methodology is that the operator need not come in conductive contact with the touch terminal but rather only in close proximity to it. A further advantage arises in that the system does not rely upon radiated emissions picked up by the operator's body which can vary with locale, but relies instead upon the human body's capacitance, which can vary over an acceptable range of 20 pF to 300 pF.

An additional consideration in using zero force switches resides in the difficulties that arise in trying to employ dense arrays of such switches. Touch switches that do not require physical contact with the operator but rather rely on the

operator's close proximity can result in unintended actuations as an operator's hand or other body part passes in close proximity to the touch terminals. Above-mentioned U.S. Pat. No. 5,087,825 employs conductive guard rings around the conductive pad of each touch terminal in an effort to decouple adjacent touch pads and prevent multiple actuations where only a single one is desired. In conjunction with the guard rings, it is also possible to adjust the detection sensitivity by adjusting the threshold voltage to which the sensed voltage is compared. The sensitivity may be adjusted in this manner to a point where the operator's body part, for instance, a finger, has to entirely overlap a touch terminal and come into contact with its dielectric facing plate before actuation occurs. Although these methods (guard rings and sensitivity adjustment) have gone a considerable way in allowing touch switches to be spaced in comparatively close proximity, a susceptibility to surface contamination remains as a problem. Skin oils, water, and other contaminants can form conductive films that overlay and capacitively couple adjacent or multiple touch pads. An operator making contact with the film can then couple multiple touch pads to his or her body capacitance and it's capacitive coupling to ground. This can result in multiple actuations where only one is desired. Small touch terminals placed in close proximity by necessity require sensitive detection circuits that in some cases are preferably isolated from interference with the associated load switching circuits that they activate.

As mentioned, in industrial controls, switches can be used to control actuation time and to ensure that the operator's hand(s) or other body part(s) are out of the field of motion of associated machinery. A common type of switch used in this application is the palm button. The button is large enough so that the operator can rapidly bring his or her hand into contact with the button without having to lose the time that would be taken in acquiring and lining up a finger with a smaller switch. Zero force touch switches are also desirable in this application as Repetitive Motion or Cumulative Trauma Disorders have been a problem with operator's utilizing palm buttons—especially those palm buttons that must be actuated against a spring resistance. In this area capacitive touch switches have also been employed. U.S. Pat. No. 5,233,231 is an example of such an implementation. Due to the proximity of machinery with the potential to cause injury, false actuations are a particular liability in such applications. Capacitive touch switches that exhibit vulnerability to radiated electromagnetic noise or that operate off operator proximity have the potential to actuate when the operator's hand(s) is not at the desired location on the palm button(s). In general, this is addressed by the use of redundancies. In U.S. Pat. No. 5,233,231, a separate detector is used to measure RF noise and disable the system to a safe state if excessive RF noise is present. Other systems such as UltraTouch vended by Pinnacle Systems, Inc. use redundant sensing methodologies. In UltraTouch, both optical and capacitive sensors are used and actuation occurs only when both sensor types detect the operator's hand at the desired location. These implementations have a number of disadvantages. In the case of the RF noise detection system, the system is unusable in the presence of RF noise. This forces the user to employ a backup mechanical switch system or accept the loss of function when RF noise is present. The second system is less reliable and more expensive because it requires two sensor systems to accomplish the same task, i.e., detect the operator. Such system may also suffer from problems inherent in any optical system, namely, susceptibility to blockages in the optical path and the need to achieve and maintain specific optical alignments. A further problem

is that this system considerably constrains the angle and direction of motion that the operator must use in activating the switch.

Currently, there are several zero force palm buttons in the market. These products utilize optical and/or capacitive coupling to activate a normally closed (NC) or a normally open (NO) relay, and thereby switching 110 V AC, 220 V AC, or 24 V DC to machine controllers. The UltraTouch by Pinnacle Systems Inc. uses two sensors (infrared & capacitive) with isolated circuits to activate a relay when a machine operator inserts his hand into a U-shaped sensor actuation tunnel. The company claims that by permitting the machine operator to activate the machine with no force or pressure and with the operator's hand and wrist in the ergonomic neutral position (i.e. 0° wrist joint angle and 100% hand power positions as shown in FIG. 1.0-1), hand, wrist, and arm stresses are minimized and contributing elements to Carpal Tunnel Syndrome are negated. After a machine cycle is initiated, the operator must maintain an initial posture until the cycle is completed. A typical cycle time lasts approximately one to two seconds and is repeated about 3000 times daily. This adds up to about one hour to one hour and a half per day while the operator is in the posture. While this module reduces stress on wrist and hand, it strains the muscles in the forearm. Also, because of limited space permitted for the operator to insert his hand, it stresses the operator mentally and reduces productivity by causing fatigue. Furthermore, the infrared emitters and detectors rely on a clean path between the transmitter and receiver and will not operate properly if contaminants block the beam of light.

#### SUMMARY OF THE INVENTION

The present invention overcomes the above problems by using the method of sensing body capacitance to ground in conjunction with redundant detection circuits. Additional improvements are offered in the construction of the touch terminal (palm button) itself and in the regime of body capacitance to ground detection which minimizes sensitivity to skin oils and other contaminants. The invention also allows the operator to utilize the system with or without gloves which is a particular advantage in the industrial setting.

The specific touch detection method of the present invention has similarities to the devices of U.S. Pat. No. 4,758,735 and U.S. Pat. No. 5,087,825. However, significant improvements are offered in the means of detection and in the development of an overall system to employ the touch switches in a dense array and in an improved zero force palm button. The touch detection circuit of the present invention features operation at frequencies at or above 50 kHz and preferably at or above 800 kHz to minimize the effects of surface contamination from materials such as skin oils and water. It also offers improvements in detection sensitivity that allow close control of the degree of proximity (ideally very close proximity) that is required for actuation and to enable employment of a multiplicity of small sized touch terminals in a physically close array such as a keyboard. The circuitry of the present invention minimizes the force required in human operator motions and eliminates awkward angles and other constraints required in those motions. The outer surface of the touch switch typically consists of a continuous dielectric layer such as glass or polycarbonate with no mechanical or electrical feed-throughs. The surface can be shaped to have no recesses that would trap or hold organic material. As a result it is easily cleaned and kept clean and so is ideal for hygienic applications such as medical or food processing equipment.

In a first preferred embodiment the circuit offers enhanced detection sensitivity to allow reliable operation with small (finger size) touch pads. Susceptibility to variations in supply voltage and noise are minimized by use of a floating common and supply that follow the oscillator signal to power the detection circuit. The enhanced sensitivity allows the use of a 26V or lower amplitude oscillator signal applied to the touch terminal and detection circuit. This lower voltage (as compared to the device of U.S. Pat. No. 4,758,735) obviates the need for expensive UL listed higher voltage construction measures and testing to handle what would otherwise be large enough voltages to cause safety concerns. A further advantage of the present invention is seen in the manner in which the touch terminal detection circuit is interfaced to the touch terminals and to external control systems. A dedicated microprocessor referenced to the floating supply and floating common of the detection circuit may be used to cost effectively multiplex a number of touch terminal detection circuits and multiplex the associated touch terminal output signals over a two line optical bus to a dedicated microprocessor referenced to a fixed supply and ground. An additional advantage of the microprocessor is an expanded ability to detect faults, i.e. a pad that is touched for an excessive amount of time that is known a priori to be an unlikely mode of operation or two or more pads touched at the same time or in an improper order. Additionally, the microprocessor can be used to distinguish desired multiple pad touches in simultaneous or sequential modes, i.e. two or more switches touched in a given order within a given amount of time. The microprocessor can be used to perform system diagnostics as well. The microprocessor also allows the use of visual indicators such as LEDs or annunciators such as a bell or tone generator to confirm the actuation of a given touch switch or switches. This is particularly useful in cases where a sequence of actuations is required before an action occurs. The feedback to the operator provided by a visual or audio indicator activated by the microprocessor in response to intermediate touches in a required sequence can minimize time lost and/or frustration on the part of the operator due to failed actuations from partial touches or wrong actuations from touching the wrong pad in a given required sequence or combination of touches. The second microprocessor may be used to communicate with the user's control system. Additional features include a "sleep mode" to minimize power consumption during periods of non-use or power brown outs, and redundant control circuits to facilitate "fail to safe" operation. Another improvement is offered in a means to move much of the cost of the system into simplified custom integrated circuits that allow ease of sensitivity adjustment and assembly.

In a second preferred embodiment, an improved palm button is featured. Through the use of a dielectric cover, a large metallic touch terminal can be used that differentiates between the touch of a finger or partial touch and the full touch of a palm. In this way the system avoids false triggers due to inadvertent finger touches or brushing contact with the palm prior or after an intended touch. The second embodiment also features redundant control circuits to facilitate "fail to safe" operation.

To achieve these and other advantages, and in accordance with the purpose of the invention as embodied and described herein, the capacitive responsive electronic switching circuit comprises an oscillator providing a periodic output signal having a frequency of 50 kHz or greater, an input touch terminal defining an area for an operator to provide an input by touch, and a detector circuit coupled to the oscillator for receiving the periodic output signal from the oscillator, and

coupled to the input touch terminal. The detector circuit being responsive to signals from the oscillator and the presence of an operator's body capacitance to ground coupled to the touch terminal when touched by an operator to provide a control output signal. Preferably, the oscillator provides a periodic output signal having a frequency of 800 kHz or greater.

These and other features, objects, and advantages of the invention may be realized and obtained by means of the instrumentalities and combinations particularly pointed out in the written description and claims hereof, as well as by the appended drawings.

#### BRIEF DESCRIPTION OF THE DRAWINGS

FIG. 1 is an electrical schematic of a testing circuit used to measure the impedance of the human body;

FIG. 2 is an electrical schematic of a testing circuit used to measure the impedance of water;

FIG. 3 is an electrical schematic of an equivalent circuit model for analyzing a human body in contact with glass covered with water;

FIG. 4 is a block diagram of a capacitive responsive electronic switching circuit constructed in accordance with a first embodiment of the present invention;

FIG. 5 is an electrical schematic of a preferred voltage regulator circuit for use in the capacitive responsive electronic switching circuit shown in FIG. 4;

FIG. 6 is an electrical schematic of a preferred oscillator circuit for use in the capacitive responsive electronic switching circuit shown in FIG. 4;

FIG. 7 is an electrical schematic of a preferred floating common generator circuit for use in the capacitive responsive electronic switching circuit shown in FIG. 4;

FIG. 8 is an electrical schematic of a preferred touch circuit for use in the capacitive responsive electronic switching circuit shown in FIG. 4;

FIG. 9 is a three dimensional bar graph illustrating signal-to-noise ratio vs. body capacitance at  $T=105^{\circ}\text{C.}$ ;

FIG. 10 is a three dimensional bar graph illustrating signal-to-noise ratio vs. body capacitance at  $T=22^{\circ}\text{C.}$ ;

FIG. 11 is a block diagram of a capacitive responsive electronic switching circuit constructed in accordance with a second embodiment of the present invention;

FIG. 12 is a block diagram of a capacitive responsive electronic switching circuit constructed in accordance with a third embodiment of the present invention;

FIG. 13 is an electrical schematic of a preferred voltage regulator, oscillator, and touch circuits for use in the capacitive responsive electronic switching circuit shown in FIG. 12;

FIG. 14 is an electrical schematic of preferred driver circuits for use in the capacitive responsive electronic switching circuit shown in FIG. 12;

FIGS. 15A-C are top, side, and front views, respectively, of an example of a flat palm button constructed in accordance with the present invention;

FIG. 16 is a cross-sectional view of an example of a dome-shaped palm button constructed in accordance with the present invention;

FIG. 17 is an electrical schematic of a touch circuit of the present invention implemented in a custom integrated circuit;

FIG. 18 is an electrical schematic of an oscillator having a sleeper circuit for use in the capacitive responsive electronic switching circuits of the present invention;

FIG. 19 is a pictorial view of a device having two palm buttons and an indicator light operated in accordance with the present invention; and

FIGS. 20A-C are pictorial views of another embodiment of the device shown in FIG. 19.

#### DETAILED DESCRIPTION OF THE PREFERRED EMBODIMENTS

As apparent from the above summary, the touch circuit of present invention operates at a higher frequency than prior touch sensing circuits. A move to high frequency operation (>50 to 800 kHz) is not a benign choice relative to the lower frequency (60 to 1000 Hz) operation seen in existing art such as U.S. Pat. No. 4,758,735 and U.S. Pat. No. 5,087,825. Higher frequencies require generally more costly, higher speed parts, and often results in the added cost of special design measures to minimize electronic emissions and the introduction of high frequency noise on power supply lines. The preference for using such higher frequencies is based on a study performed to determine if high frequency operation would allow a touch of an operator and conduction via surface contamination films, such as moisture, providing a conductive path from a non-touched area to the touched area. The study also determined whether a high frequency touch circuit could operate over a sufficiently wide temperature range, an assortment of overlying dielectric layer thicknesses and materials, and in the presence of likely power supply fluctuations. The following calculations and measurements are the results of this study. The results summarize the investigation conducted to reduce crosstalk due to condensation of water on the dielectric member (glass). By increasing the frequency of operation, the impedance of the body-glass combination is reduced as compared to the impedance of water between the touch pads.

The equivalent circuit of body impedance was measured using the testing circuit 10 shown in FIG. 1. Testing circuit 10 includes an oscillator 20 coupled between ground plate and a 100 k $\Omega$  series resistor 22 and in parallel with a 10 M $\Omega$  resistor 24, a 20 pF capacitor 26, and contacts for connecting to a human body identified in the figure as an impedance load 15 having an impedance  $Z_B$  representing the body's impedance.

Two types of measurements were taken: one with the person under test standing on a large ground plane i.e., concrete slab; and another while standing on a subfloor. The subfloor was used to simulate a typical northern home, i.e., wood joists with plywood sheeting. Carpeting was used as an added insulation layer. Table 1 below shows the measured body resistance and capacitance for five individuals.

TABLE 1

CONCRETE SLAB	CONCRETE SLAB	SUBFLOOR	SUBFLOOR
1.4 k $\Omega$	100 pF	1.7 k $\Omega$	73 pF
1.4 k $\Omega$	217 pF	1.9 k $\Omega$	78 pF
1.3 k $\Omega$	174 pF	1.9 k $\Omega$	93 pF
1.2 k $\Omega$	160 pF	1.6 k $\Omega$	85 pF
1.0 k $\Omega$	107 pF	1.4 k $\Omega$	75 pF

As apparent from Table 1 above and the discussion to follow, a human body's impedance may be represented by the series combination of a 20-300 pF capacitor and a 1 k-2 k $\Omega$  resistor.

The impedance of water, which is mainly resistive, was measured using the testing circuit 30 shown in FIG. 2. Testing circuit 30 includes an oscillator 40 coupled in series with a 1 M $\Omega$  resistor 42 and contacts across which water is

applied to define an impedance load 35 having an impedance  $Z_w$ , representing the impedance of water. A true RMS voltage meter 45 is connected across the contacts of the impedance load 35.

The resistance of tap water over a 1x1 inch area and 1/32 inch deep, was measured to be around 160 kΩ.

The following calculation is for resistance of rain water where  $c$  is the conductivity for rain:

$$R = \left( \frac{1}{c \cdot l} \right) \times \left( \frac{l}{A} \right)$$

where,

$$c = 128 \times 10^{-6} (\Omega \cdot \text{cm})^{-1}$$

$$c \cdot l = c \left( \frac{100 \text{ cm}}{\text{m}} \right) \left( \frac{.0254 \text{ m}}{\text{m}} \right)$$

$$L = 1.0 \text{ in}$$

$$A = (1.0) \times \left( \frac{1}{32} \right) = \frac{1}{32} \text{ in}^2$$

therefore,

$$R = \left( \frac{1}{325.12 \times 10^{-6}} \right) \times \left( \frac{1.0 \text{ m}}{\frac{1}{32} \text{ in}^2} \right) = 98.43 \text{ k}\Omega$$

However, the thickness of a layer of water condensed on the surface of glass is much less than 1/32 inch and its resistance is higher than that of tap water. For design purposes, a resistance value of 1 MΩ was used to simulate water.

The capacitance of a piece of glass measuring 1/2"x1/2"x1/4", is approximately 2 pF.

$$C = K_{glass} K_a \frac{A(\text{cm}^2)}{L(\text{cm})} (\mu\text{F})$$

$$K_g = 0.08842 \times 10^{-6} \text{ for vacuum}$$

$$6.0 < K_{glass} < 10$$

$$A = 0.25 \text{ in}^2$$

$$L = 0.25 \text{ in}$$

therefore,

$$C_{max} = 10 \times 0.08842 \times 10^{-6} \times 2.54 \times 10^{-6} = 2.25 \text{ pF}$$

$$C_{min} = 6 \times 0.08842 \times 10^{-6} \times 2.54 \times 10^{-6} = 1.35 \text{ pF}$$

Table 2 below shows the dielectric constant for several types of glass:

TABLE 2

TYPE OF GLASS	Dielectric Constant (K)
Corning 0010	6.32
Corning 0080	6.75
Corning 0120	6.65
Corning 8870	9.5

The equivalent circuit 50 of body touching the glass with the presence of water is shown in FIG. 3. As shown, the equivalent circuit 50 includes a polycarbon (PCB) plate 55 having at least two pads 57 and 59 formed thereon, a glass plate 60 adjacent to PCB plate 55, water 65 on glass plate 60 spanning at least two touch pad areas, and a body 70 in

contact with the water 65 and glass plate 60 at one touch pad area. The impedance of glass plate 60 is approximated by two 2 pF capacitors 62 and 64 connected to pads 57 and 59, respectively. The water 65 is approximated by a 1 MΩ resistor 68 connected between capacitors 62 and 64. The body is represented by a 20-300 pF capacitor 72 coupled at one end to water resistor 68 and glass plate capacitor 62, and by a 1-2 kΩ resistor 74 coupled between the other end of capacitor 72 and ground.

Referring to FIG. 3, it can be seen that a human touch opposite pad 57 will couple pad 57 to ground through the capacitance of glass 62 and the series contact with the human body impedance provided by the 20-300 pF capacitance and the 1 k-2 kΩ resistance of a typical human body. This will have the effect of pulling any voltage on the pad towards ground. Pad 59 will be similarly effected, however it's coupling to ground will not only be through capacitance 64, and the series capacitance and resistance of the human body, but will also be through the ohmic resistance of water on the glass cover between the proximate location of pad 59 and the touched pad 57. Because the human capacitance is considerably greater than the 2 pF capacitance of the glass, the impedance of the path to ground for pads 57 and 59 will be dominated by the glass and water impedances. If the impedance of the water path is significant compared to that of the glass, then the effect of a touch will be more significant at pad 57 than at pad 59. To overcome the effect of condensation or possible water spills, the impedance of the glass is preferably made as small as is practical compared to the impedance of the water. This allows discrimination between touched and adjacent pads. As the water impedance is primarily resistive and the glass impedance is primarily capacitive, the impedance of the glass will drop with frequency.

FIG. 3A shows the maximum and minimum glass impedance as a function of frequency. The maximum and minimum glass impedances shown were computed as follows:

$$\epsilon_g = 8.854 \times 10^{-12} C^2 / (\text{mm}^2)$$

$$K_{gmin} = 6$$

$$K_{gmax} = 10$$

$$A = 0.25 \text{ in}^2$$

$$L = 0.25 \text{ in}$$

$$C_{max} = K_{gmax} \epsilon_g A / L, C_{max} = 2.249 \text{ pF}$$

$$C_{min} = K_{gmin} \epsilon_g A / L, C_{min} = 1.349 \text{ pF}$$

$$Z_{gmin\_frequency} = 1 / (2 \pi C_{max} \text{frequency})$$

$$Z_{gmax\_frequency} = 1 / (2 \pi C_{min} \text{frequency})$$

As can be seen, at 1 kHz, the capacitive impedance of the glass is much greater than the nominal 1 MΩ of the water bridge between the pads. As a result, at 1 kHz, there would be little difference in the impedance paths to ground of the two adjacent pads when either is touched. This would result in the voltage on both pads being pulled towards ground by comparable amounts. Conversely, at 100 kHz, the glass impedance drops to approximately 1 MΩ resulting in the impedance of the path to ground for pad 59 being twice that of the touched pad 57. For cases where background noise and temperature drifts are comparatively small, a 100 kHz oscillator frequency would allow a sufficiently low detection threshold to be set to differentiate between the signal changes induced at both pads by a human touch opposite a

single pad. At 800 kHz, the impedance of the glass drops to 200 k $\Omega$  or lower giving a ratio of a greater than 5 to 1 impedance difference between the paths to ground of the touched pad 57 and adjacent pads 59. In fact, the impedance ratio may exceed 10 to 1, as illustrated in the calculation below. This allows the detection threshold for the touched pad to be set well below that of an adjacent pad resulting in a much lower incidence of inadvertent actuation of adjacent touch pads to that of the touched pad. Ideally, the frequency of operation would be kept at the 800 kHz of the preferred embodiment or even higher. However, as noted earlier, higher frequency operation forces the use of more expensive components and designs. For applications where thermal drift and electronic noise levels are low, operation at or near 100 kHz may be possible. However, at 10 kHz and below, the impedance of the glass becomes much greater than that of likely water bridges between pads resulting in adjacent pads being effected as much by a touch as the touched pad itself. Although the preferred frequency is at or above 100 kHz, and more preferably at or above 800 kHz, it is conceivable that frequencies as low as 50 kHz could be used provided the frequency creates a difference in the impedance paths of adjacent pads that is sufficient enough to accurately distinguish between an intended touch and the touch of an adjacent pad. Use of frequencies as low as 50 kHz may also be possible depending upon the type of glass or covering or the thickness thereof used for the touch pad. However, in cases where there is little or no surface contamination, the frequency of operation can go well below 50 kHz. Ultimately, the frequency chosen will be a tradeoff between the likelihood of surface contamination and the cost of going to higher frequencies to prevent cross talk due to such contamination. The following analysis illustrates one example of how a frequency may be calculated based on the typical parameters used to construct a touch switch and the typical impedance of a contaminant, such as rain water. In the analysis below a 10 to 1 ratio of water to glass impedance is sought.

To eliminate crosstalk due to condensation of water on the glass, the impedance of body ( $Z_B$ ) and glass ( $Z_g$ ) combination must be much lower than impedance of water ( $Z_w$ ). Since the impedance of glass is much higher than body impedance,  $Z_g$  will be considered only. Therefore,

$$10Z_g < 1Z_w \quad \text{Eq. 3}$$

where,

$$C_{glass} = 2 \text{ pF} \quad Z_w = 1 \text{ M}\Omega$$

$$Z_g = \frac{1}{2\pi f C_g} = \frac{7.96 \times 10^{10}}{f} \quad \text{Eq. 4}$$

$$10 \times \left( \frac{7.96 \times 10^{10}}{f} \right) < 1 \text{ M}\Omega$$

Therefore,

$$f > 796 \text{ kHz}$$

Having provided a basis for the use of higher frequencies, the basic construction of the electronic switching circuit constructed in accordance with a first embodiment of the present invention is now described with reference to FIG. 4. The electronic switching circuit includes a voltage regulator 100 including input lines 101 and 102 for receiving a 24 V AC line voltage and a line 103 for grounding the circuit. Voltage regulator 100 converts the received AC voltage to a

DC voltage and supplies a regulated 5 V DC power to an oscillator 200 via lines 104 and 105. Voltage regulator also supplies oscillator 200 with 26 V DC power via line 106. The details of voltage regulator 100 are discussed below with reference to FIG. 5.

Upon being powered by voltage regulator 100, oscillator 200 generates a square wave with a frequency of 50 kHz, and preferably greater than 800 kHz, and having an amplitude of 26 V peak. The square wave generated by oscillator 200 is supplied via line 201 to a floating common generator 300, a touch pad shield plate 460, a touch circuit 400, and a microcontroller 500. Oscillator 200 is described below with reference to FIG. 6.

Floating common generator 300 receives the 26 V peak square wave from oscillator 200 and outputs a regulated floating common that is 5 volts below the square wave output from oscillator 200 and has the same phase and frequency as the received square wave. This floating common output is supplied to touch circuit 400 and microcontroller 500 via line 301 such that the output square wave from oscillator 200 and floating common output from floating common generator 300 provide power to touch circuit 400 and microcontroller 500. Details of floating common generator 300 are discussed below with reference to FIG. 7.

Touch circuit 400 senses capacitance from a touch pad 450 via line 451 and outputs a signal to microcontroller 500 via line 401 upon detecting a capacitance to ground at touch pad 450 that exceeds a threshold value. The details of touch circuit 400 are described below with reference to FIG. 8.

Upon receiving an indication from touch circuit 400 that a sufficient capacitance to ground (typically at least 20 pF) is present at touch pad 450, microcontroller 500 outputs a signal to a load-controlling microcontroller 600 via line 501, which is preferably a two way optical coupling bus. Microcontroller 600 then responds in a predetermined manner to control a load 700. Having generally described the basic construction of the first embodiment, the preferred detailed construction of the depicted components will now be described with FIGS. 5-8. In cases where the number of lines to be switched is low, microcontroller 600 can be replaced by additional optical coupling lines. The number of lines to be switched will dictate whether it is more cost effective to multiplex over a two line optical bus such as line 501 and use a microcontroller to demultiplex, or to use a multiplicity of optical coupling lines. Other considerations such as reliability and power consumption may also affect this choice. In this preferred embodiment, the use of a single pair of optical coupling paths (line 501) and a microcontroller 600, is shown to emphasize the capability to switch a large number of lines.

A preferred circuit for implementing a voltage regulator 100 is shown in FIG. 5. Voltage regulator 100 preferably includes an AC/DC converter 110 for generating 29 V to 36 V unregulated DC on line 119. This unregulated DC power is supplied to a 5 V DC regulator 120 and to a 26 V DC regulator 130. AC/DC converter 110 includes diodes 112, 114, 116, and 118, which rectify the supplied 24 V AC power provided on power lines 101 and 102. The anode of the first diode 112 is coupled to power line 101 and to the cathode of the second diode 114. The cathode of the first diode 112 is coupled to output line 119. The anode of the second diode 114 is coupled to ground via line 103 and to the anode of the fourth diode 118. The anode of the third diode 116 is coupled to the cathode of the fourth diode 118 and to power line 102. The cathode of the third diode 116 is coupled to line 119 and to the cathode of the first diode 112. The anode of the fourth diode 118 is coupled to ground via line 103. Diodes 112, 114, 116, and 118 are preferably diodes having part no. 1N4002

available from LITEON. AC/DC convertor 110 also preferably includes a capacitor 115 for filtering the rectified output of the diodes. Capacitor 115 is preferably a 1000  $\mu\text{F}$  capacitor coupled between output line 119 and ground via line 103.

The 5 V regulator 120 preferably includes a 500  $\Omega$  resistor 122 coupled between line 119 and 5 V output line 104, and a zener diode 124, a first capacitor 126, and second capacitor 128 all connected and parallel between output power lines 104 and 105. Preferably, zener diode 124 is a 5.1 V zener diode having part no. 1N4733A available from LITEON, first capacitor 126 has a capacitance of 10  $\mu\text{F}$ , and second capacitor 128 has a capacitance of 0.1  $\mu\text{F}$ .

The 26 V regulator 130 preferably includes a transistor 134 having a collector connected to line 119 via a first resistor 132, a base connected to line 119 via a second resistor 136, and an emitter coupled to the regulated 26 V output power line 106. The 26 V regulator 130 also preferably includes a capacitor 137 and zener diode 138 connected in parallel between the base of transistor 134 and ground line 103. Preferably, first resistor 132 is a 20  $\Omega$ , 0.5 W resistor, second resistor 136 is a 1  $\text{k}\Omega$ , 0.5 W resistor, capacitor 137 is a 0.1  $\mu\text{F}$  capacitor, and zener diode 138 is a 27 V, 0.5 W diode having part no. 1N5254B available from LITEON. It will be apparent to those skilled in the art, that various components of voltage regulator 100 may be added or excluded depending upon the source of power available to power the oscillator 200. For example, if the available power is a 110 V AC 60 Hz commercial power line, a transformer may be added to convert the 110 V AC power to 24 V AC. Alternatively, if a DC battery is used, the AC/DC convertor among other components may be eliminated.

A preferred example of an 800 kHz oscillator is shown in FIG. 6. Oscillator 200 preferably includes a square wave generator 210, which is powered by 5 V regulator 120 via lines 104 and 105, for generating a 5 V peak square wave having the desired frequency, and a buffer circuit 230 powered by 26 V regulator 130 via line 106 for buffering the output of square wave generator 210 and boosting its peak from 5 V to 26 V while maintaining the preferred frequency. Square wave generator 210 is preferably an astable multivibrator constructed with at least two serially connected inverter gates 212 and 214, and optionally, a third serially connected inverter gate 216. Inverter gates 212, 214 and 216 are preferably provided in a single integrated circuit designated as part 74HC04 available from National Semiconductor. The output of the first inverter gate 212 is coupled to its input via resistors 218 and 222 and is coupled to the input of the second inverter gate 214 via a capacitor 224. The input of the second inverter gate 214 is directly connected to the output of the first inverter gate 212 and the output of the second inverter gate 214 is directly connected to the input of the optional third inverter gate 216. To provide an 800 kHz output, resistor 218 preferably has a 10.0  $\text{k}\Omega$  value, resistor 222 preferably has a 1.78  $\text{k}\Omega$  value, and capacitor 224 is preferably a 220 pF capacitor.

The 5 V peak square wave generated by square wave generator 210 is supplied from either the output of inverter gate 214 or the output of optional inverter gate 216 to the base of a first transistor 238 via a first resistor 232 connected and parallel a capacitor 234. The base of first transistor 238 is connected to the 26 V regulated DC power line 106 via a second resistor 236. The collector of first transistor 238 is connected to 26 V power line 106 via a third resistor 240 and to the base of a second transistor 244. The emitter of first transistor 238 is coupled to ground and to its own collector and the base of second transistor 244 via a fourth resistor 242. The collector of the second transistor 244 is connected

directly to 26 V power line 106 and the emitter of second transistor 244 is connected to ground via a fifth resistor 246. Second transistor 244 provides the 26 V peak square wave on output line 201, which is connected to its emitter. In operation, the square wave signal applied to the base of transistor 238 causes the collector of transistor 238 to swing between near to the DC supply 106 voltage and the collector-emitter saturation voltage. Capacitor 234 is provided to improve the turning off of transistor 238. Transistor 244 along with resistors 242 and 246 are used to buffer the square wave signal generated by transistor 238. In a preferred embodiment, the values of the resistors and capacitor are as follows: first resistor 232 is 5.1  $\text{k}\Omega$ , capacitor 234 is 0.0047  $\mu\text{F}$ , second resistor 236 is 1  $\text{M}\Omega$ , third resistor 240 is 1.6  $\text{k}\Omega$ , fourth resistor 242 is 100  $\text{k}\Omega$ , and fifth resistor 246 is 4.7  $\text{k}\Omega$ . Preferably, transistors 238 and 244 are those identified as part no. ZTX600 available from ZETEX. In this configuration, the oscillator 200 sources 80 mA to the floating common generator 300 such that together they supply a floating 5 V DC to power touch circuit(s) 400, microcontroller 500, and Schmitt triggered gates 420 (FIG. 8). As will be apparent to those skilled in the art, the values of the resistors and capacitors utilized in oscillator 200 may be varied from those disclosed above to provide for different oscillator output frequencies. As discussed above, however, oscillator 200 is preferably constructed so as to output a square wave having a frequency of 50 kHz or greater, and more preferably, of 800 kHz or greater. In some cases it may be necessary to use lower gain bandwidth product transistors or filtration to achieve a softer roll-off of the square edges to reduce high frequency noise emissions. When this is done the amplitude of the oscillator voltage can be increased to compensate.

The preferred construction of floating ground generator 300 is shown in FIG. 7 includes a zener diode 310 having a cathode connected to the oscillator output on line 201 and an anode connected to floating ground output line 301 and to ground via resistor 316 and diode 318. Floating ground generator 300 also preferably includes a first capacitor 312 and a second capacitor 314 connected in parallel with zener diode 310. In the preferred embodiment, zener diode 310 is a 5.1 V zener diode identified by part no. 1N4733A available from LITEON, capacitor 312 is a 47  $\mu\text{F}$  tantalum capacitor, capacitor 314 is a 0.1  $\mu\text{F}$  capacitor, resistor 316 is a 270  $\Omega$  resistor, and diode 318 is a diode identified as part no. 1N914B available from LITEON.

Touch circuit 400, as shown in FIG. 8, preferably includes a transistor 410 having a base connected to touch pad 450 via resistor 413 and line 451, an emitter coupled to oscillator output line 201, and a collector coupled to floating ground line 301 via a pulse stretcher circuit 417, which includes a resistor 416 and a capacitor 418 connected in parallel. To minimize susceptibility to noise, the physical length of the path between the touch pad 450 and the base of the transistor 410, must be held to a minimum. Additionally, RC filters can be placed in line 401 between the output of the touch circuit 400 and the input of the microcontroller 500 to give additional EMI/RFI immunity. Additionally, the higher the frequency, the higher the gain bandwidth product that is required in transistor 410. The gain bandwidth product must be sufficient to guarantee that the oscillator turns on during oscillator High pulses. A further trade-off is to use higher gain bandwidth product to allow lower oscillator voltages or higher oscillator voltages to all allow a lower gain bandwidth product transistor to be used. The combination of oscillator voltage, frequency and transistor gain bandwidth product that is used will necessarily vary with the cost,

safety and reliability requirements of a given application. The present combination was chosen to keep the oscillator voltage down and allow operation at 800 kHz to minimize cross talk. At higher frequencies a higher gain bandwidth product transistor would be required in both the oscillator 200 and detection 400 circuits. Touch circuit 400 also preferably includes resistor 412 and a diode 414 having an anode connected to the base of transistor 410 and to resistor 413, and a cathode connected to the emitter of transistor 410 and to a resistor 412 connected in parallel with diode 414 between the base and emitter of transistor 410. The pulse stretcher circuit 417 is identified as such because the sensitivity of the touch circuit may be increased or decreased by varying the resistance of resistor 416. The base of transistor 410 is connected via resistor 413 to line 451 connected to touch pad 450.

Additionally, touch circuit 400 may include at least one Schmitt triggered gate 420 powered by the voltage difference existing between oscillator line 201 and 301, and having an input terminal coupled to the collector of transistor 410 and an output coupled to microcontroller 500 via output line 401. Schmitt triggered inverter gate 420 is optionally provided to improve the rise time of the touch switch output and to buffer the output. Preferably, transistor 410 is part no. BC258CL available from Motorola, resistor 412 is a 12 M $\Omega$  resistor, diode 414 is part no. 1N914B available from Diodes, Inc., resistor 416 is a 470 k $\Omega$  resistor, capacitor 418 is a 0.001  $\mu$ F capacitor, and resistor 413 is a 10 k $\Omega$  resistor.

As stated above, the operator's body includes a capacitance to ground, which may range in a typical person from between 20 to 300 pF. The base terminal of transistor 410 is coupled to its emitter by resistor 412 such that unless capacitance is present by the user touching the touch pad 450, transistor 410 will not be forward biased and will not conduct. Thus, when touch pad 450 is not touched, the output signal at the collector terminal of transistor 410 and across pulse stretcher circuit 417 will be zero volts. When, however, a person touches the touch pad 450, that person's body capacitance to ground couples the base of transistor 410 to ground 103 through resistor 413, thereby forward biasing transistor 410 into conduction. This charges capacitor 418 providing a positive DC voltage with respect to the line 301 and causes the output of the Schmitt trigger 420 to go low. Diode 414 is coupled across the base to emitter junction of transistor 410 to clamp the base emitter reverse bias voltage to  $-0.7$  V and also reduce the forward recovery and turn-on time.

Touch pad 450 includes a substrate on which a plurality of electrically conductive plate members are mounted on one surface thereof. The substrate is an insulator and the plates are spaced apart in order to insulate the plates from one another and from ground. Also, positioned on the substrate is a guard band, generally shown as 460. Guard band 460 is a grid of conductor segments extending between adjacent pairs of plate members. All conductor segments are physically interconnected to define a plurality of spaces with one plate member positioned centrally within each space. Components of the touch circuit may be positioned on the side of substrate opposite plate members and guard band 460.

A planar dielectric member is spaced from the substrate facing plate members. The dielectric member is made from a non-porous insulating material such as polycarbonate or glass. A plurality of electrically conductive spring contacts are sandwiched between the inner surface of the dielectric member and the substrate. An indicia layer may be adhered to the inner surface of the dielectric member to provide an indication of the function of each input portion.

As mentioned above, interface between the dielectric member and a conductive plate is a metallic spring contact that is attached to the back of the dielectric member. The spring contacts offer advantages at high temperature extremes. However, for sufficiently narrow temperature ranges, conductive polymer foam pads cut to the size of the touch pads are preferably used to fill the gap between conductive pad and dielectric layer. The function of the spring contacts or conductive foam pads is to eliminate that capacitive contribution of the air filled gap between the conductive pads and the overlying dielectric layer.

A problem with capacity responsive keyboards is the tendency of switches that are closely positioned in a keyboard system to inadvertently become actuated even though the user is touching an adjacent switch. Furthermore, this problem is greatly aggravated by the presence of contamination on the outer surface of dielectric member. Contamination such as skin oil or moisture causes erratic keyboard operation and multiple switches will turn on even though one switch is touched. By operating at a high frequency such as 100 kHz or 800 kHz, the impedance of the series combination of body and glass capacitance are lowered as compared to the impedance of contamination present on the glass thereby reducing crosstalk.

If glass thickness is smaller than  $\frac{1}{16}$  inch, the touch circuit becomes more sensitive to body capacitance. There are two ways to adjust the sensitivity so that crosstalk does not occur: remove diode 414 and/or reduce the resistance of resistor 416. Increasing the resistance of resistor 416 would allow usage of thicker glass. However, this resistance preferably should not go above 750 k $\Omega$ . This is because of the maximum low input voltage of 0.8 V and input leakage current of 1  $\mu$ A at the Schmitt trigger gate 420.

The oscillator circuitry shown in FIG. 6 is very stable over the temperature range of  $-40^{\circ}$  C. to  $105^{\circ}$  C. The output of the touch switch circuitry drops at a rate of approximately 40 mV/ $^{\circ}$ C. when temperature falls below  $0^{\circ}$  C. If application requires operation at low temperatures ( $-40^{\circ}$  C.), the following three methods may be used to increase the output of the switch: increase the oscillator's regulated supply voltage, increase the resistance of resistor 416, and use a higher gain transistor 410. All of these methods would increase sensitivity at high temperatures. Another way to correct this problem is to use a thermistor to vary the regulated supply voltage as a function of temperature.

Since the input power is regulated down to 26 V DC, variation of power (24 V AC $\pm$ 10% or 29 V DC to 36 V DC) does not affect circuit operation. Table 3 below shows the measured output voltage of the switch for various supply voltages.

TABLE 3

SUPPLY VOLTAGE	SWITCH OUTPUT
36 VDC	4.96 V
35 VDC	4.96 V
34 VDC	4.95 V
33 VDC	4.95 V
32 VDC	4.94 V
31 VDC	4.93 V
30 VDC	4.93 V
29 VDC	4.92 V

$$PSRR=6 \text{ mV/V}=-45 \text{ dB}$$

In order to determine the effect of body capacitance on circuit operation, the circuit of FIG. 3 was used to simulate glass, water resistance, and body capacitance. The following two conditions were simulated and tested:

- 1—The maximum body capacitance that does not cause crosstalk when:  
 Temperature=105° C.  
 Supply Voltage=36VDC  
 Glass Capacitance=2 pF  
 Water Resistance=330 k to 1 MΩ
  - 2—The minimum capacitance to turn on a switch when:  
 Temperature=0° C.  
 Supply Voltage=29VDC  
 Glass Capacitance=2 pF
  - 3—Operation at room temperature.
- Table 4 below shows the signal and noise voltages at the switch output for different values of body capacitance and contamination resistance.

TABLE 4

CONTAMINATION RE-SISTANCE	BODY CAPACITANCE				
	20 pF	220 pF	330 pF	550 pF	1230 pF
330 kΩ	S: 5.1 V N: 2.0 V	S: 5.1 V N: 4.0 V	S: 5.1 V N: 4.5 V	S: 5.1 V N: 4.9 V	S: 5.1 V N: 5.0 V
500 kΩ	S: 5.1 V N: 0.2 V	S: 5.1 V N: 0.6 V	S: 5.1 V N: 0.7 V	S: 5.1 V N: 0.8 V	S: 5.1 V N: 0.8 V
1 MΩ (Condensed Water)	S: 5.1 V N: 0.1 V	S: 5.1 V N: 0.1 V	S: 5.1 V N: 0.1 V	S: 5.1 V N: 0.1 V	S: 5.1 V N: 0.1 V
NONE	S: 5.1 V N: 10 mV	S: 5.1 V N: 10 mV	S: 5.1 V N: 10 mV	S: 5.1 V N: 10 mV	S: 5.1 V N: 10 mV

S = Signal (TOUCH)  
 N = Noise (NO TOUCH)  
 supply voltage = 36 VDC  
 temperature = 105° C.

With contamination resistance of 1 MΩ or more, the circuit is insensitive to body capacitance variations and has a minimum signal-to-noise ratio of -34 dB. With no contamination, signal-to-noise ratio is approximately -54 dB. The graph in FIG. 9 shows the signal-to-noise ratio versus body capacitance, for different values of contamination resistance at 105° C. The minimum body capacitance to turn on a switch is 20 pF.

At room temperature, crosstalk decreases because of gain drop of transistor 410. Table 5 below shows that at room temperature, the circuit rejects 250 kΩ of contamination, independent of body capacitance. Below 250 kΩ, body capacitance will affect crosstalk.

TABLE 5

CONTAMINATION RE-SISTANCE	BODY CAPACITANCE				
	20 pF	220 pF	330 pF	550 pF	1230 pF
200 kΩ	S: 5.1 V N: 0.2 V	S: 5.1 V N: 1.0 V	S: 5.1 V N: 1.2 V	S: 5.1 V N: 1.8 V	S: 5.1 V N: 2.2 V
250 kΩ	S: 5.1 V N: 0.1 V	S: 5.1 V N: 0.1 V	S: 5.1 V N: 0.5 V	S: 5.1 V N: 0.5 V	S: 5.1 V N: 0.5 V
330 kΩ	S: 5.1 V N: 0.1 V	S: 5.1 V N: 0.1 V	S: 5.1 V N: 0.1 V	S: 5.1 V N: 0.1 V	S: 5.1 V N: 0.1 V
1 MΩ (Condensed Water)	S: 5.1 V N: 0.1 V	S: 5.1 V N: 0.1 V	S: 5.1 V N: 0.1 V	S: 5.1 V N: 0.1 V	S: 5.1 V N: 0.1 V

S = Signal (TOUCH)  
 N = Noise (NO TOUCH)  
 supply voltage = 36 VDC  
 temperature = 25° C.

The graph of FIG. 10 shows the measured signal-to-noise ratio versus body capacitance, for different contamination resistance values at room temperature.

The particular advantages of the preceding circuit over that of existing touch detection circuits such as that disclosed in U.S. Pat. No. 4,758,735, are the use of diode 414 (selected for high speed) to minimize forward recovery time rather than merely provide reverse polarity protection (as with the slower type of diode used in the existing circuits) and the omission of a capacitor coupled across the base to emitter junction of the detection transistor 410 to make the circuit more sensitive and operable with a lower oscillator amplitude and higher oscillator frequency. These features along with appropriate choices in component values make possible operation at significantly higher frequencies (>50 to 800 kHz) than are seen in existing art (60 to 1000 Hz). At frequencies at or near 800 kHz, the 20-300 pF of capacitance to ground offered by the human body presents a considerably lower impedance than the primarily resistive impedance of skin oil or water films that may appear on the dielectric layer overlying the conductive touch pads. This allows the peak voltage of a pad that is touched to come considerably closer to ground than adjacent pads which will have a voltage drop across any contaminating film layer that is providing a conductive path to the area that is touched. The enhanced sensitivity offered by the omission of any capacitor between the base and emitter of the detection transistor 410, allows the threshold of detection to be set much closer to ground than would be the case otherwise. This allows discrimination between the pad that is touched and adjacent pads that might be pulled towards ground via the conductive path to the touch formed by a contaminating film. This high frequency regime of operation offers a considerable advantage relative to the existing art in terms of immunity to surface contaminants such as skin oil and moisture.

A multiple touch pad circuit constructed in accordance with the second embodiment is shown in FIG. 11. In the second embodiment of FIG. 11, components similar to those in the first embodiment in FIG. 4 are designated with the same references numerals and will not be discussed in detail. The multiple touch pad circuit is a variation of the first embodiment in that it includes an array of touch circuits designated as 900<sub>1</sub> through 900<sub>nm</sub>, which, as shown, include both the touch circuit 400 shown in FIGS. 4 and 8 and the input touch terminal pad 451 (FIG. 4). Microcontroller 500 selects each row of the touch circuits 900<sub>1</sub> to 900<sub>nm</sub> by providing the signal from oscillator 200 to selected rows of touch circuits. In this manner, microcontroller 500 can sequentially activate the touch circuit rows and associate the received inputs from the columns of the array with the activated touch circuit(s). To keep the path length 451 between the touch pad 450 and the base to the detection transistor 410 to a minimum, the detection circuits 900 are physically located directly beneath the touch pads. To simplify assembly, a flexible circuit board such as vended by Sheldahl, Inc. or Circuit Etching Technics, Inc. can be used for this purpose. Ideally, the printed circuit will be fixed directly against the surface (typically glass) bearing the conductive touch pads to eliminate air gaps and the need for conductive foam pads and spring contacts which were used to fill air gaps.

For this second embodiment, the oscillator 200 of the first embodiment may be slightly modified from that shown in FIG. 6 to include a transistor (not shown) coupled between the oscillator output and ground with its base connected to microcontroller 600 such that microcontroller 600 may selectively disable the output of oscillator 200.

The use of a high frequency in accordance with the present invention provides distinct advantages for circuits



such as the multiple touch pad circuit of the present invention due to the manner in which crosstalk is substantially reduced without requiring any physical structure to isolate the touch terminals. Further, the reduction in crosstalk afforded by the present invention, allows the touch terminals in the array to be more closely spaced together.

A third embodiment of the present invention, which provides touch circuit redundancy, is described below with reference to FIGS. 12-14. As shown in FIG. 12, the switching circuit according to the third embodiment includes a voltage regulator 1100 for regulating power supplied by 24 V DC power lines 1101 and 1102 with ground connection 1103, for supplying the regulated power to an oscillator 1200 via lines 1104 and 1107.

Oscillator 1200 supplies a continuous and periodic signal to touch circuits 1400a and 1400b via line 1201. Preferably, the frequency of the oscillator output signal is at least 100 kHz, and more preferably, at least 800 kHz. The two touch circuits 1400a and 1400b are identical in construction and both receive the output of touch terminal 1450 via line 1451. A detailed description of the preferred voltage regulator circuit 1100, oscillator 1200, and touch circuits 1400a and 1400b is provided below with reference to FIG. 13 following the description of the remaining portion of the third embodiment.

The output of the first touch circuit 1400a is supplied to a first driver circuit 1500 via line 1401a while the output of the second touch circuit 1400b is supplied to a second driver circuit 1600 via line 1401b. The two driver circuits 1500 and 1600 are provided to drive first and second serially connected switching transistors 1700 and 1710. The switching transistors 1700 and 1710 must both be conducting to supply power to a relay switch 1800. Thus, if one of touch circuits 1400a and 1400b does not detect a touch of touch terminal 1450, one of switching transistors 1700 and 1710 will not conduct and power will not be supplied to relay switch 1800. The preferred construction of driver circuits 1500 and 1600 and relay switch 1800 are described below with reference to FIG. 14.

As shown in FIG. 13, voltage regulator 1100 may be constructed by providing a first capacitor 1110 and a varistor 1112 connected in parallel across input power terminals 1101 and 1102. Preferably, return power terminal 1102 is connected via line 1103 to ground. Varistor 1112 is used to protect the circuit for over-voltage conditions. Also connected in parallel with first capacitor 1110 and varistor 1112, are the serially connected combination of a fuse 1114, a diode 1116, a resistor 1118 and two parallel connected capacitors 1120 and 1122. The voltage regulator 1100 is reverse polarity protected by diode 1116 and current limited by resistor 1118. Capacitors 1120 and 1122 provide filtering.

Voltage regulator 1100 further includes a zener diode 1128 having its cathode connected to a node between resistor 1118 and capacitors 1120 and 1122 and to output power line 1104. The anode of zener diode 1128 is coupled to output power common line 1107 and to ground line 1103 via two serially connected resistors 1124 and 1126. Zener diode 1128 and resistors 1124 and 1126 generate regulated 15 V DC. Two capacitors 1130 and 1132 are connected in parallel with zener diode 1128 between power lines 1104 and 1107. Capacitors 1130 and 1132 provide filtering and decoupling, respectively. Preferably, capacitor 1110 has a capacitance of 1000 pF, 1000V, varistor 1112 is part no. S14K25 available from Siemens, fuse 1114 is a ¼A fuse, diode 1116 is part no. 1N4002 available from LITEON, resistor 1118 has a resistance of 10Ω, ½W, capacitor 1120 has a capacitance of 22 μF, 35V, capacitor 1122 has a

capacitance of 0.1 μF, zener diode 1128 is part no. 1N4744A available from LITEON, resistor 1124 has a resistance of 220Ω, resistor 1126 has a resistance of 220Ω, capacitor 1130 has a capacitance of 1 μF, 25V, and capacitor 1132 has a capacitance of 0.1 μF.

Oscillator 1200 is preferably comprised of a first inverter gate 1210 having its input coupled to its output via resistors 1214 and 1216, and a second inverter gate 1212 having its input coupled to the output of first inverter gate 1210 and its output coupled to its input via a capacitor 1218 and resistor 1216. The oscillating output of the second inverter gate 1212 is buffered via transistor 1226, which has its base connected to the output of second inverter gate 1212 via resistor 1220 and capacitor 1222, which are connected in parallel therebetween. The base of transistor 1226 is also coupled to power line 1104 via a resistor 1224. The emitter of transistor 1226 is connected to power line 1104 and the collector is connected to power line 1107 via a resistor 1230, to the anode of a diode 1228, and to the oscillator output line 1201. Diode 1228 has its cathode connected to power line 1104 and is used to protect transistor 1226.

Preferably, inverter gates 1210 and 1212 are provided by part no. CD40106B available from Harris, resistor 1214 has a resistance of 10 kΩ, resistor 1216 has a resistance of 1.18 kΩ, 1%, capacitor 1218 has a capacitance of 220 pF, resistor 1220 has a resistance of 4.7 kΩ, capacitor 1222 has a capacitance of 220 pF, resistor 1224 has a resistance of 100 kΩ, transistor 1226 is part no. MMBTA70L available from Motorola, diode 1228 is part no. RLS4448 available from LITEON, and resistor 1230 has a resistance of 3.3 kΩ.

Two touch circuits 1400a and 1400b are provided in parallel to provide redundancy so that if one fails, the relay drivers are disabled. Because the touch circuits 1400a and 1400b are identical, only one of the touch circuits will now be described. Touch circuit 1400a preferably includes two resistors 1410a and 1412a coupled in series between touch terminal output line 1451 and the base of a bipolar PNP transistor 1420a. Transistor 1420a has its emitter connected to the oscillator output line 1201 and its collector connected to power common line 1107 via a resistor 1422a. Touch circuit 1400a further includes a diode 1414a, a capacitor 1416a, and a resistor 1418a all connected in parallel between the base of transistor 1420a and the emitter thereof, which is connected to oscillator output line 1201. Touch circuit 1400a also includes a diode 1424a having its anode connected to the collector of transistor 1420a and its cathode connected to touch circuit output line 1401a via a resistor 1426a.

Preferably, resistor 1410a has a resistance of 5.1 kΩ, resistor 1412a has a resistance of 5.1 kΩ, diode 1414a is part no. RLS4448 available from LITEON, capacitor 1416a has a capacitance of 240 pF, resistor 1418a has a resistance of 12 MΩ, transistor 1420a is part no. BC857CL available from Motorola, resistor 1422a has a resistance of 100 kΩ, diode 1424a is part no. RLS4448 available from LITEON, and resistor 1426a has a resistance of 100 kΩ.

The preferred detailed construction of the first and second driver circuits 1500 and 1600 will now be described with reference to FIG. 14. In first driver circuit 1500, the output line 1401a of first touch circuit 1400a is connected to power common line 1107 via a resistor 1510 and also via a capacitor 1512 connected in parallel therewith. The output line 1401a is also connected to the inverting input terminal of an operational amplifier 1514. The non-inverting input terminal of operational amplifier 1514 is connected to line 1502, which runs between first and second driver circuits

1500 and 1600 and is connected to power line 1104 via a resistor 1626. The output of op amp 1514 is connected to power line 1104 via a resistor 1518 and to the input of a Schmitt trigger inverter gate 1516. The output of Schmitt trigger inverter gate 1516 is connected to the input of a second Schmitt trigger inverter gate 1526 via a resistor 1520. A diode 1522 is connected in parallel with resistor 1520 with its cathode connected to the output of inverter gate 1516 and its anode connected to the input of inverter gate 1526 and to power common line 1107 via capacitor 1524. The output of inverter gate 1526 is connected to the base of bipolar PNP switching transistor 1700 via a resistor 1528. The base of transistor 1700 is also connected to power common line 1107 via a capacitor 1532 and to power line 1104 and its emitter via a resistor 1530.

Preferably, resistor 1510 has a resistance of 10 M $\Omega$ , capacitor 1512 has a capacitance of 0.01  $\mu$ F, op amp comparator 1514 is part no. LM393 available from National Semiconductor, inverter gate 1516 is part no. CD40106B available from Harris, resistor 1518 has a resistance of 10 k $\Omega$ , resistor 1520 has a resistance of 1 M $\Omega$ , diode 1522 is part no. RLS4448 available from LITEON, capacitor 1524 has a capacitance of 0.22  $\mu$ F, inverter gate 1526 is part no. CD40106 available from Harris, resistor 1528 has a resistance of 12 k $\Omega$ , resistor 1530 has a resistance of 100 k $\Omega$ , capacitor 1532 has a capacitance of 0.01  $\mu$ F, and transistor 1700 is part no. MMBTA56L available from Motorola.

In second driver circuit 1600, the output line 1401b of second touch circuit 1400b is connected to power common line 1107 via a resistor 1610 and also via a capacitor 1612 connected in parallel therewith. The output line 1401b is also connected to the inverting input terminal of an operational amplifier 1614. The non-inverting input terminal of operational amplifier 1614 is connected to line 1502, which is connected to power line 1104 via resistor 1626. The non-inverting input terminal of op amp 1614 is also connected to power common line 1107 via a capacitor 1616 and a resistor 1618, which are connected in parallel. The output of op amp 1614 is connected to power line 1104 via a resistor 1630 and to the coupled inputs of a Schmitt trigger inverter gate 1628. The output of op amp 1614 is also connected to its non-inverting input terminal via a resistor 1624. The output of Schmitt trigger inverter NAND gate 1628 is connected to the input of a second Schmitt trigger inverter gate 1638 via a resistor 1632. A diode 1634 is connected in parallel with resistor 1632 with its cathode connected to the output of inverter NAND gate 1628 and its anode connected to the input of inverter NAND gate 1638 and to power common line 1107 via a capacitor 1636. The output of inverter gate 1638 is connected to the base of switching bipolar PNP transistor 1710 via a resistor 1640. The base of transistor 1710 is also connected to power common line 1107 via a capacitor 1642 and to power line 1104 via a resistor 1644. Second driver circuit 1600 also preferably includes capacitors 1620 and 1622 connected in parallel between its connections to power lines 1104 and 1107.

Preferably, resistor 1610 has a resistance of 10 M $\Omega$ , capacitor 1612 has a capacitance of 0.01  $\mu$ F, op amp comparator 1614 is part no. LM393 available from National Semiconductor, capacitor 1616 has a capacitance of 0.01  $\mu$ F, resistor 1618 has a resistance of 20 k $\Omega$ , capacitor 1620 has a capacitance of 0.1  $\mu$ F, capacitor 1622 has a capacitance of 0.1  $\mu$ F, resistor 1624 has a resistance of 100 k $\Omega$ , resistor 1626 has a resistance of 10 k $\Omega$ , inverter NAND gate 1628 is part no. CD4093B available from Harris, resistor 1630 has a resistance of 10 k $\Omega$ , resistor 1632 has a resistance of 1 M $\Omega$ , diode 1634 is part no. RLS4448 available from

LITEON, capacitor 1636 has a capacitance of 0.22  $\mu$ F, inverter NAND gate 1638 is part no. CD4093B available from Harris, resistor 1640 has a resistance of 12 k $\Omega$ , capacitor 1642 has a capacitance of 0.01  $\mu$ F, resistor 1644 has a resistance of 100 k $\Omega$ , and transistor 1710 is part no. MMBTA56L available from Motorola.

In operation, the output of transistor 1420a (FIG. 13) taken at its collector is rectified by diode 1424a and a DC level is generated by resistors 1426a and 1510 and capacitor 1512 (a DC level of the output of transistor 1420b is generated by resistors 1426b and 1610 and capacitor 1612). When this DC level exceeds the upper threshold voltage of op amp comparator 1514 (1614), the output of schmitt triggered inverter gate 1516 inverter NAND gate 1628 (1628) goes high which charges capacitor 1524 (1636) through resistor 1520 (1632). Gates 1516 and 1526 (1628 and 1638), resistor 1520 (1632), and capacitor 1524 (1636) provide debounce in a conventional manner. Diode 1522 (1634) is used to provide fast release when the palm of the hand is removed from the touch terminal 1450. The output of the debounce circuitry drives transistor 1700 (1710). Resistor 1528 (1640) and capacitor 1532 (1642) are used to filter noise. Both touch circuits must be functional in order to drive the relay switch 1800. Also, if one of the transistors 1700 or 1710 fails, the relay will not be activated.

Relay switch 1800 may be any conventional relay. An example of such a relay is shown in FIG. 14. Relay switch 1800 may include a relay coil 1810 coupled between the selective power supply 1711 of transistors 1700 and 1710 and ground, and a pair of magnetically responsive switches that switch from normally closed terminals 1805 and 1807 to normally open terminals 1801 and 1803 when the relay coil is energized. A zener diode 1815 may be placed in series with a diode 1820 to reduce stress on the relay coil 1810 and to protect transistor 1710 when transistors 1700 and 1710 switch off.

Although the touch circuits of the third embodiment are disclosed as operating a relay switch via driver circuits, it will be appreciated by those skilled in the art that the outputs of touch circuits 1400a and 1400b could be supplied to a microcontroller in the manner discussed above with respect to the first embodiment.

The palm button switch of the present invention uses two redundant touch switch circuits, such as shown in FIG. 12, to disable relay drivers if one of the touch switch circuits fails and redundant relay driver circuitry to turn off a relay switch if one of the driver circuits fails.

Alternatively, the circuitry shown in FIG. 4 could be used. In another embodiment a method to prevent inadvertent actuations is to require a multi-step process. Referring to FIG. 19, a device is shown having a first palm button 2201, a second palm button 2202, and an indicator light 2205. Palm button 2201 has to be activated first and then button 2202 has to be activated within a 2 second time window before a desired actuation can occur. The 90 degree orientation of the two buttons makes it extremely difficult to accidentally touch both with an arm and an elbow or other such physical combination. An added advantage is that the motion required to move the hand from button 2201 to button 2202 can provide some relief from fatigue in the forearm by the resulting muscle flexure that would otherwise not occur if the hand had to be kept near a single button for extended periods of time. A further redundancy can be achieved by requiring simultaneous operation of two such devices, one for each hand. This provides further safeguards against inadvertent actuations and forces the operator to have both hands in a desired safe location once a desired

actuation occurs. A further option is to provide one or more LEDs 2205 or audible annunciators for visual or audible feedback to the operator. Specifically, in FIG. 19 the LED 2205 will come on when button 2201 has been successfully activated to cue the operator that it is time to move to button 2202. Where required a second LED with a different color than the first (yellow for the first LED and red for the second) can be provided to provide visual confirmation that the second button 2202 has been activated or that the required combination of the two buttons has been activated. Two different audible tone or sound generators could also be used in lieu of the LEDs to provide feedback to the operator. In industrial or other challenging settings, the housing is made of high strength polycarbonate (or other high strength non-metallic material) to meet high impact and vibration requirements, preferably NEMA 4. A further option is to provide lighting for the switches to allow operation in the dark.

In a variation of the multi-step process, two touch plates within a housing (one vertical and one horizontal) are used to provide a two-step turn-on. Referring to FIGS. 20A-C, the first step to actuate the output relay 2310, is initiated when the operator inserts his hands and touches the vertical touch sensor 2301 with the dorsal side of the hands. A yellow LED 2304 on top of the device show the successful completion of the first step. The second step is to flip the hand over and touch the horizontal touch sensor 2302 with the palmar side of the hand. A red LED 2305 on top of the device shows the completion of the two step turn-on and activation of output relay 2310. The flipping action of the hand in the second step causes the forearm muscles to flex, thereby reducing stiffness and fatigue. Also, the hands, and arms can rest on the run bar until the machine cycle is complete. The second step of the two-step turn-on must occur within some predetermined time (for example 2 seconds) after the release of vertical touch sensor or the first step must be repeated. In this proposed embodiment, the second step provides an added stimulus and reduces operator errors due to mental and physical fatigue. The top cover prevents actuation of two devices by the use of one hand and elbow of the same arm, as required by ANSI Standard B11.19-1990. The enclosure must be a high strength polycarbonate module to meet the high impact and vibration requirements of the industry, preferably NEMA 4. In both embodiments, high frequency switching is used to desensitize the unit against moisture and contaminants that could generate a path between the button and grounded chassis. The palm button may be formed as the flat palm button shown in FIGS. 15A-C or as a dome-shaped palm button shown in FIG. 16. The button is made of a brass plate 1910 (1930) and can be covered with a plastic or glass 1925 (1933) cover or membrane to desensitize the unit even more against contaminants and other inadvertent actuation. The plastic cover 1925 (1933) acts as a dielectric and capacitance is varied as a function of the area of the plastic being touched. Therefore, if button is touched by finger, a much smaller series capacitance is generated as opposed to button being touched by the palm of a hand. This capacitance is placed in series with the capacitance of the body to ground when the button is touched. Since the capacitance of the body to ground is much larger than the capacitance generated by the button, the functionality of the unit is independent of the variations in body capacitance to ground from person to person. The other factor that needs to be considered here is body resistance. If the button is not covered with an insulator such as plastic, the unit would become sensitive to body resistance. Body resistance to ground, changes as a function of moisture in the work area,

skin dryness, floor structure, and shoes. By using a plastic cover, the unit is made insensitive to variations of body resistance and capacitance. The shape of the button is also a factor in sensitivity. If the button is flat, less of the button area would be covered by the palm of the hand as opposed to a dome shape button that matches the contour of the palm. Therefore, if the button is dome-shaped, the unit can be even more desensitized against inadvertent operation.

By providing a large space for hand insertion and switch activation and a flat or dome shape button where the palm of the hand rests while machine cycle is in process, stress on the forearms is ergonomically reduced. The palm button of the present invention can be activated with or without gloves. The zero force palm button of the present invention may be used to activate electric, pneumatic, air clutch, and hydraulic equipment such as punch presses, molding machines, etc.

As shown in FIGS. 15A-C, the flat palm button may include a plastic housing 1917 having an optional metallic enclosure 1922 for surface mounting. The button also may include a flush mount surface 1915 and optional guarding 1920.

The circuit board 1935 used with the palm button of the present invention may be packaged on two printed circuit boards. One board for power and relay and the other for touch switches and relay drivers. The touch circuit on the touch switch board is interfaced to the button through a screw that also holds the button in place. The power/relay board is interfaced to the touch switch board through a three pin right angle connector. Wiring to the unit is done through a seven position terminal block on the power/relay board. The power/relay board is designed for 24 V DC input power and provides two double-throw relay contacts. However, it can be modified to accommodate different power inputs and switch outputs. For example, a transformer may be added to the power board so that the unit is powered 110VAC/220VAC instead of 24 V DC. Also, the relays may be replaced with other outputs such as digital or 4-20 mA outputs.

The touch circuit components can be integrated in a custom IC 2000, as shown in FIG. 17, to facilitate manufacturing and to reduce cost. Components 413, 412, 414, 410, 418, and 420 are similar to those of circuit 400 shown in FIG. 8. Preferably, resistor 2004 has a resistance of 470 k $\Omega$  and diode 2002 has characteristics similar to part no. 1N4148 available from LITEON. Resistors 2008 and 2006 are used to adjust the sensitivity. Diode 2002 at the output of 420, allows the IC to be used in applications where several touch circuit IC's are multiplexed.

As shown in FIG. 18, a sleep circuit 2100 may be added to the oscillator circuit 200 (FIG. 6) to allow microcontroller 600 to turn off the oscillator circuit 200. The disabling of oscillator circuit 200 is done to reduce drainage of capacitor 126 in the regulator circuit 120 during brown outs. The circuit diagram shown in FIG. 18 is a modified version of circuit 200 in FIG. 6. During normal operation microcontroller 600 pulls the input of gate 2116 to ground and causes the output of gate 2116 to go high (power line 104). Therefore, transistor 2110 is biased on and oscillator 200 is functional. When in a sleep mode, microcontroller 600 sources the input to gate 2116 high and causes the output of gate 2116 to go low which turns off transistor 2110 and pulls the input of gate 212 low. Therefore, the oscillator will stop oscillating and drainage on capacitor 126 decreases considerably.

The above described embodiments were chosen for purposes of describing but one application of the present

invention. It will be understood by those who practice the invention and by those skilled in the art, that various modifications and improvements may be made to the invention without departing from the spirit or scope of the invention as defined by the appended claims.

The embodiments of the invention in which an exclusive property or privilege is claimed are defined as follows:

1. A capacitive responsive electronic switching circuit comprising:

an oscillator providing a periodic output signal having a frequency of 50 kHz or greater;

an input touch terminal having a dielectric cover defining an area for an operator to provide an input by proximity and touch, an operator's body capacitance to ground as sensed through said input touch terminal varying as a function of the area of said input touch terminal that is proximate the operator's body; and

a detector circuit coupled to said oscillator for receiving said periodic output signal from said oscillator, and coupled to said input touch terminal, said detector circuit being responsive to signals from said oscillator and the presence of an operator's body capacitance to ground coupled to said touch terminal when proximal or touched by an operator to provide a control output signal, wherein said detector circuit includes means for generating said control signal when the sensed body capacitance to ground exceeds a threshold level in order to prevent unintended activation based upon an operator's inadvertent proximity and touch with said input touch terminal.

2. The switching circuit as defined in claim 1, wherein said oscillator provides a periodic output signal having a frequency of 800 kHz or greater.

3. The switching circuit as defined in claim 1 and further including a DC power supply for supplying power to said oscillator and a ground.

4. The switching circuit as defined in claim 1, wherein said periodic output signal provided by said oscillator is a square wave output signal, said oscillator includes a square wave generator for generating a square wave, and a plurality of active elements coupled to an output of said square wave generator to buffer and improve the shape of the square wave output therefrom.

5. The switching circuit as defined in claim 1, wherein said detector circuit includes a microcontroller and a charge pump circuit coupled between said input touch terminal and said microcontroller.

6. The switching circuit as defined in claim 1, wherein said detector circuit includes a microcontroller and a touch circuit coupled between said input touch terminal and said microcontroller.

7. The switching circuit as defined in claim 6 and further including a plurality of said input touch terminals and a plurality of said touch circuits respectively associated with said input touch terminals.

8. The switching circuit as defined in claim 7, wherein said microcontroller selectively applies said periodic output signals received from said oscillator to each of said touch circuits to separately activate each touch circuit.

9. A capacitive responsive electronic switching circuit comprising:

an oscillator providing a periodic output signal having a frequency of 50 kHz or greater;

an input touch terminal defining an area for an operator to provide an input by proximity and touch;

a detector circuit coupled to said oscillator for receiving said periodic output signal from said oscillator, and

coupled to said input touch terminal, said detector circuit being responsive to signals from said oscillator and the presence of an operator's body capacitance to ground coupled to said touch terminal when proximal or touched by an operator to provide a control output signal; and

a floating common generator coupled to said oscillator for receiving said square wave output signal, said floating common generator generating a floating common reference for said detector circuit that is set at a fixed voltage below and tracks the square wave output signal.

10. The switching circuit as defined in claim 9, wherein said detector circuit is powered by said square wave output signal provided by said oscillator and by said floating common reference provided by said floating common generator thereby increasing the sensitivity of said detector circuit to proximity and touching of said touch terminal by an operator's body.

11. The switching circuit as defined in claim 10, wherein said detector circuit includes a microcontroller and a charge pump circuit coupled between said input touch terminal and said microcontroller, by an operator's body, wherein said charge pump circuit includes at least one high speed diode coupled between said oscillator and said touch terminal, for enhancing a sensitivity at which said charge pump responds to sensed body capacitance at said touch terminal for higher frequencies.

12. A proximity and touch controlled switching circuit comprising:

an oscillator providing a square wave output signal having a frequency of 50 kHz or greater;

a touch terminal having a dielectric cover defining an input terminal for coupling to an operator's body capacitance to ground; and

a charge pump circuit coupled to said oscillator for receiving said square wave output signal, and coupled to said touch terminal, said charge pump circuit having an output terminal that supplies an output signal having a voltage that varies when said touch terminal is proximal or touched by an operator's body, the voltage of said output signal varies as a function of the area of said touch terminal that is proximal or touched by an operator.

wherein said charge pump circuit includes at least one high speed diode coupled between said oscillator and said touch terminal, for enhancing a sensitivity at which said charge pump responds to sensed body capacitance to ground at said touch terminal for higher frequencies.

13. The proximity and touch controlled circuit as defined in claim 12 and further including a DC power supply for supplying power to said oscillator and a ground.

14. The proximity and touch controlled circuit as defined in claim 12, wherein said oscillator includes a square wave generator for generating a square wave, and a plurality of active elements coupled to an output of said square wave generator to buffer and improve the shape of the square wave output therefrom.

15. The proximity and touch controlled circuit as defined in claim 12, wherein said oscillator provides a periodic output signal having a frequency of 800 kHz or greater.

16. A proximity and touch controlled switching circuit comprising:

an oscillator providing a square wave output signal having a frequency of 50 kHz or greater;

a touch terminal defining an input terminal for coupling to an operator's body capacitance to ground;

27

a charge pump circuit coupled to said oscillator for receiving said square wave output signal, and coupled to said touch terminal, said charge pump circuit having an output terminal that supplies an output signal having a voltage that varies when said touch terminal is proximal or touched by an operator's body; and

a floating common generator coupled to said oscillator for receiving said square wave output signal, said floating common generator generating a floating common reference for said charge pump circuit that is set at a fixed voltage below and tracks said square wave output signal.

wherein said charge pump circuit includes at least one high speed diode coupled between said oscillator and said touch terminal, for enhancing a sensitivity at which said charge pump responds to sensed body capacitance to ground at said touch terminal for higher frequencies.

17. The proximity and touch controlled circuit as defined in claim 16, wherein said charge pump circuit is powered by said square wave output signal provided by said oscillator and by said floating common reference provided by said floating common generator thereby increasing the sensitivity of said charge pump circuit to proximity and touching of said touch terminal by an operator's body.

18. A capacitive responsive electronic switching circuit comprising:

an oscillator providing a periodic output signal having a predefined frequency;

a plurality of input touch terminals defining adjacent areas on a dielectric substrate for an operator to provide inputs by proximity and touch; and

a detector circuit coupled to said oscillator for receiving said periodic output signal from said oscillator, and coupled to said input touch terminals, said detector circuit being responsive to signals from said oscillator and the presence of an operator's body capacitance to ground coupled said touch terminals when proximal or touched by an operator to provide a control output signal,

wherein said predefined frequency of said oscillator is selected to decrease the impedance of said dielectric substrate relative to the impedance of any contaminate that may create an electrical path on said dielectric substrate path between said adjacent areas, and wherein said detector circuit compares the sensed body capacitance to ground proximate an input touch terminal to a threshold level to prevent inadvertent generation of the control output signal.

19. The switching circuit as defined in claim 18, wherein said oscillator provides a periodic output signal having a frequency of 800 kHz or greater.

20. A capacitive responsive electronic switching circuit comprising:

an oscillator providing a periodic output signal having a predefined frequency;

a dome-shaped touch terminal defining an area for an operator to provide an input by proximity and touch, wherein the dome shape of the touch terminal is constructed to ergonomically fit the palm of a human hand; and

a detector circuit coupled to said oscillator for receiving said periodic output signal from said oscillator, and coupled to said touch terminal, said detector circuit being responsive to signals from said oscillator and the presence of an operator's body capacitance to ground

28

coupled to said touch terminal when proximal or touched by an operator to provide a control output signal, said detector circuit including means for discriminating between a proximity and touch of said dome-shaped touch terminal by the palm of a human hand and a proximity and touch by a human finger.

21. A capacitive responsive electronic switching circuit comprising:

an oscillator providing a periodic output signal having a predefined frequency;

a touch terminal defining an area for an operator to provide an input by proximity and touch; and

a detector circuit coupled to said oscillator for receiving said periodic output signal from said oscillator, and coupled to said touch terminal, said detector circuit being responsive to signals from said oscillator and the presence of an operator's body capacitance to ground coupled to said touch terminal when proximal or touched by an operator to provide a control output signal, said detector circuit including discriminating means for discriminating between a proximity and touch of said touch terminal covering substantially all of said area of said touch terminal and a proximity and touch covering less than substantially all of said area of said touch terminal.

22. The switching circuit as defined in claim 21, wherein said touch terminal includes a dome-shaped dielectric cover.

23. The switching circuit as defined in claim 21, wherein said touch terminal includes a palm-sized dielectric cover.

24. The switching circuit as defined in claim 23, wherein said discriminating means determines that a proximity and touch of said touch terminal covers substantially all of said area of said touch terminal when said dielectric cover is proximal or touched with the palm of an operator's hand and determines that a proximity or touch covers less than substantially all of said area of said touch terminal when said dielectric cover is proximal or touched with one of an operator's fingers.

25. The switching circuit as defined in claim 21, wherein said discriminating means discriminates between a proximity and touch of said touch terminal covering substantially all of said area of said touch terminal and a proximity and touch covering less than substantially all of said area of said touch terminal based upon a sensed level of body capacitance to ground proximate said touch terminal.

26. The switching circuit as defined in claim 21, wherein said coupling of capacitance to ground occurs when an operator's body is proximate, but not touching, said touch terminal.

27. A capacitive responsive electronic switching circuit for a controlled device comprising:

an oscillator providing a periodic output signal having a predefined frequency;

first and second touch terminals defining areas for an operator to provide an input by proximity and touch; and

a detector circuit coupled to said oscillator for receiving said periodic output signal from said oscillator, and coupled to said first and second touch terminals, said detector circuit being responsive to signals from said oscillator and the presence of an operator's body capacitance to ground coupled to said first and second touch terminals when proximal or touched by an operator to provide a control output signal for actuation of the controlled device, said detector circuit being con-

29

figured to generate said control output signal when said an operator is proximal or touches said second touch terminal after the operator is proximal or touches said first touch terminal.

28. The capacitive responsive electronic switching circuit as defined in claim 27, wherein said detector circuit generates said control signal only when an operator is proximal or touches said second touch terminal within a predetermined time period after the operator is proximal or touches said first touch terminal.

29. The capacitive responsive electronic switching circuit as defined in claim 27, wherein said first and second touch terminals are adapted to be mounted on different surfaces of the controlled device.

30

30. The capacitive responsive electronic switching circuit as defined in claim 27, wherein said first and second touch terminals are adapted to be mounted on non-parallel planar surfaces of the controlled device.

31. The capacitive responsive electronic switching circuit as defined in claim 27, wherein said first and second touch terminals are adapted to be mounted on perpendicular planar surfaces of the controlled device.

32. The capacitive responsive electronic switching circuit as defined in claim 27 and further including an indicator for indicating when said detector circuit determines that an operator is proximal or touches said first touch terminal.

\* \* \* \* \*

UNITED STATES PATENT AND TRADEMARK OFFICE  
**CERTIFICATE OF CORRECTION**

PATENT NO. : 5,796,183  
DATED : August 18, 1998  
INVENTOR(S) : Byron Hourmand

Page 1 of 3

It is certified that error appears in the above-identified patent and that said Letters Patent is hereby corrected as shown below:

Column 5, line 52, "such a" should be --such as--.

Column 9, line 31, before "water" insert --condensed--.

Column 14, line 35, "is" should be --as--.

Column 13, line 65, "it's" should be --its--.

Column 18, line 38, "references" should be --reference--.

Column 20, line 7, "it's" should be --its-- (both occurrences).

Column 20, line 9, "it's" should be --its--.

Column 20, line 10, "it's" should be --its-- (both occurrences).

Column 20, line 13, "it's" should be --its--.

Column 20, line 20, "it's" should be --its--.

Column 20, line 39, "it's" should be --its--.

Column 20, line 40, "it's" should be --its--.

Column 20, line 46, "it's" should be --its--.

Column 20, line 47, "it's" should be --its--.

UNITED STATES PATENT AND TRADEMARK OFFICE  
**CERTIFICATE OF CORRECTION**

PATENT NO. : 5,796,183  
DATED : August 18, 1998  
INVENTOR(S) : Byron Hourmand

Page 2 of 3

It is certified that error appears in the above-identified patent and that said Letters Patent is hereby corrected as shown below:

Column 21, line 8, "it's" should be --its--.

Column 21, line 9, "it's" should be --its--.

Column 21, line 15, "it's" should be --its--.

Column 21, line 42, "it's" should be --its--.

Column 21, line 46, "it's" should be --its--.

Column 21, line 47, "it's" should be --its--.

Column 21, line 56, "it's" should be --its--.

Column 22, line 8, "it's" should be --its--.

Column 22, line 13, "schmitt" should be --Schmitt--.

Column 26, lines 22-27, after "microcontroller." delete "by an operator's body . . . higher frequencies."



UNITED STATES PATENT AND TRADEMARK OFFICE  
**CERTIFICATE OF CORRECTION**

PATENT NO. : 5,796,183  
DATED : August 18, 1998  
INVENTOR(S) : Byron Hourmand

Page 3 of 3

It is certified that error appears in the above-identified patent and that said Letters Patent is hereby corrected as shown below:

Column 27, line 44, after "electrical" insert "--path--".

Column 27, line 45, delete "path".

Column 29, line 1, after "when" delete "said".

Signed and Sealed this  
Eleventh Day of May, 1999

Attest:



Q. TODD DICKINSON

Attesting Officer

Acting Commissioner of Patents and Trademarks

UNITED STATES PATENT AND TRADEMARK OFFICE  
**CERTIFICATE OF CORRECTION**

PATENT NO. : 5,796,183  
APPLICATION NO. : 08/601268  
DATED : August 18, 1998  
INVENTOR(S) : Byron Hourmand et al.

Page 1 of 1

It is certified that error appears in the above-identified patent and that said Letters Patent is hereby corrected as shown below:

Title Page, Item (75) Inventor, should read --(75) Inventors: Byron Hourmand,  
Hersey, MI (US); John M. Washeleski, Cadillac, MI (US); Stephen R. W. Cooper,  
Fowlerville, MI (US)--.

Signed and Sealed this  
Eleventh Day of October, 2011

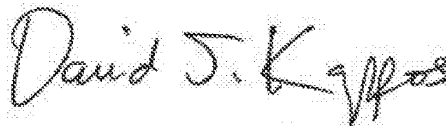

David J. Kappos  
*Director of the United States Patent and Trademark Office*

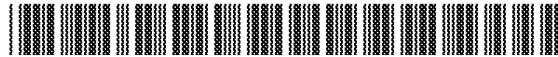

US005796183C1

(12) **EX PARTE REEXAMINATION CERTIFICATE** (9614th)  
**United States Patent**  
Hourmand et al.

(10) **Number:** US 5,796,183 C1

(45) **Certificate Issued:** Apr. 29, 2013

(54) **CAPACITIVE RESPONSIVE ELECTRONIC SWITCHING CIRCUIT**

(75) **Inventors:** Byron Hourmand, Hersey, MI (US);  
John M. Washeleski, Cadillac, MI (US);  
Stephen R. W. Cooper, Fowlerville, MI (US)

(73) **Assignee:** Nartron Corporation, Reed City, MI (US)

(58) **Field of Classification Search**  
None  
See application file for complete search history.

(56) **References Cited**

To view the complete listing of prior art documents cited during the proceeding for Reexamination Control Number 90/012,439, please refer to the USPTO's public Patent Application Information Retrieval (PAIR) system under the Display References tab.

*Primary Examiner* — Linh M. Nguyen

**Reexamination Request:**  
No. 90/012,439, Aug. 17, 2012

**Reexamination Certificate for:**  
Patent No.: 5,796,183  
Issued: Aug. 18, 1998  
Appl. No.: 08/601,268  
Filed: Jan. 31, 1996

Certificate of Correction issued May 11, 1999

Certificate of Correction issued Oct. 11, 2011

(57) **ABSTRACT**

A capacitive responsive electronic switching circuit comprises an oscillator providing a periodic output signal having a frequency of 50 kHz or greater, an input touch terminal defining an area for an operator provide an input by proximity and touch, and a detector circuit coupled to the oscillator for receiving the periodic output signal from the oscillator, and coupled to the input touch terminal. The detector circuit being responsive to signals from the oscillator and the presence of an operator's body capacitance to ground coupled to the touch terminal when in proximity or touched by an operator to provide a control output signal. Preferably, the oscillator provides a periodic output signal having a frequency of 800 kHz or greater. An array of touch terminals may be provided in close proximity due to the reduction in crosstalk that may result from contaminants by utilizing an oscillator outputting a signal having a frequency of 50 kHz or greater.

(51) **Int. Cl.**  
H03K 17/96 (2006.01)  
H03K 17/94 (2006.01)  
(52) **U.S. Cl.**  
USPC ..... 307/116; 307/125; 307/139; 361/181

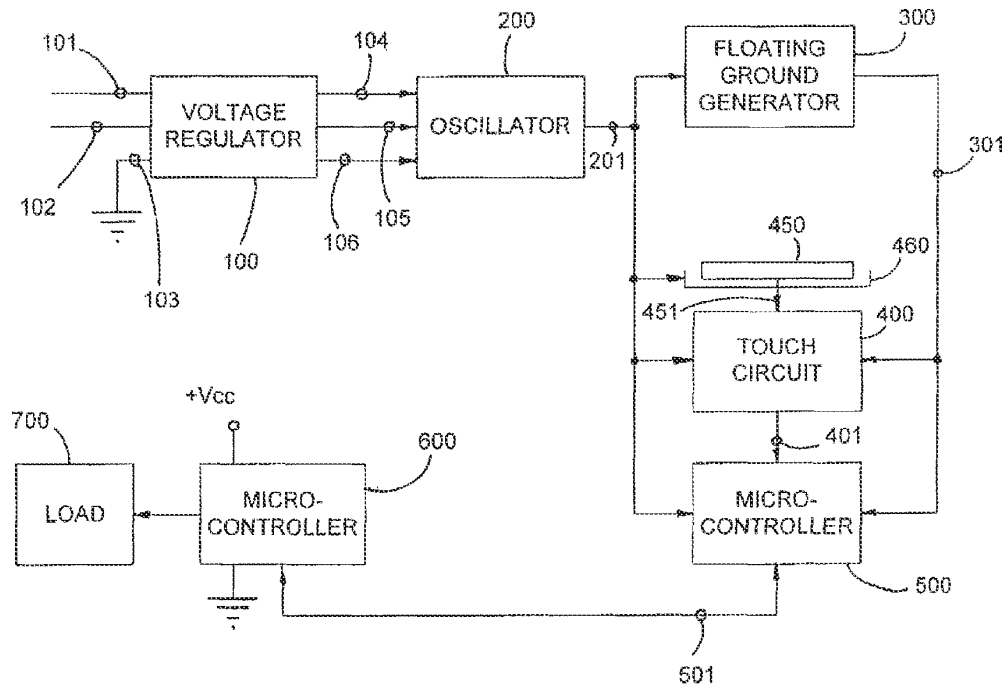

1  
EX PARTE  
REEXAMINATION CERTIFICATE  
ISSUED UNDER 35 U.S.C. 307

THE PATENT IS HEREBY AMENDED AS  
INDICATED BELOW.

Matter enclosed in heavy brackets [ ] appeared in the patent, but has been deleted and is no longer a part of the patent; matter printed in italics indicates additions made to the patent.

AS A RESULT OF REEXAMINATION, IT HAS BEEN DETERMINED THAT:

Claims 18, 27, 28 and 32 are determined to be patentable as amended.

New claims 33-39 are added and determined to be patentable.

Claims 1-17, 19-26 and 29-31 were not reexamined.

18. A capacitive responsive electronic switching circuit comprising:

an oscillator providing a periodic output signal having a predefined frequency;

*a microcontroller using the periodic output signal from the oscillator, the microcontroller selectively providing signal output frequencies to a plurality of small sized input touch terminals of a keypad;*

[a] the plurality of *small sized* input touch terminals defining adjacent areas on a dielectric substrate for an operator to provide inputs by proximity and touch; and  
a detector circuit coupled to said oscillator for receiving said periodic output signal from said oscillator, and coupled to said input touch terminals, said detector circuit being responsive to signals from said oscillator via said microcontroller and [the] a presence of an operator's body capacitance to ground coupled to said touch terminals when proximal or touched by [an] the operator to provide a control output signal,

wherein said predefined frequency of said oscillator [is] and said signal output frequencies are selected to decrease [the] a first impedance of said dielectric substrate relative to [the] a second impedance of any contamine that may create an electrical path on said dielectric substrate between said adjacent areas *defined by the plurality of small sized input touch terminals*, and wherein said detector circuit compares [the] a sensed body capacitance change to ground proximate an input touch terminal to a threshold level to prevent inadvertent generation of the control output signal.

27. A capacitive responsive electronic switching circuit for a controlled keypad device comprising:

an oscillator providing a periodic output signal having a predefined frequency;

*a microcontroller using the periodic output signal from the oscillator, the microcontroller selectively providing signal output frequencies to a closely spaced array of input touch terminals of a keypad, the input touch terminals comprising first and second input touch terminals;*

*the first and second input touch terminals defining areas for an operator to provide an input by proximity and touch;* and

a detector circuit coupled to said oscillator for receiving said periodic output signal from said oscillator, and coupled to said first and second touch terminals, said

2

detector circuit being responsive to signals from said oscillator via said microcontroller and [the] a presence of an operator's body capacitance to ground coupled to said first and second touch terminals when proximal or touched by [an] the operator to provide a control output signal for actuation of the controlled keypad device, said detector circuit being configured to generate said control output signal when [an] the operator is proximal or touches said second touch terminal after the operator is proximal or touches said first touch terminal.

28. The capacitive responsive electronic switching circuit as defined in claim 27, wherein said detector circuit generates said control signal only when [an] the operator is proximal or touches said second touch terminal within a predetermined time period after the operator is proximal or touches said first touch terminal.

32. The capacitive responsive electronic switching circuit as defined in claim 27 and further including an indicator for indicating when said detector circuit determines that [an] the operator is proximal or touches said first touch terminal.

33. *The capacitive responsive electronic switching circuit as defined in claim 18, further comprising wherein said detector circuit compares the sensed body capacitance change caused by the body capacitance decreasing an input touch terminal signal on the detector to ground when proximate to the input touch terminal to a second threshold level to generate the control output signal.*

34. *The capacitive responsive electronic switching circuit as defined in claim 18, further comprising wherein said detector circuit compares the sensed body capacitance change caused by the body capacitance decreasing an input touch terminal signal amplitude on the detector to ground when proximate to the input touch terminal to a second threshold level to generate the control output signal.*

35. *The capacitive responsive electronic switching circuit as defined in claim 27, wherein when the second touch terminal is not touched on its defining area by the operator to provide input, the control output signal is prevented.*

36. *The capacitive responsive electronic switching circuit as defined in claim 27 and further including an indicator for indicating when said detector circuit determines that the operator is proximal or touches said second touch terminal.*

37. *A capacitive responsive electronic switching circuit for a controlled device comprising:*

*an oscillator providing a periodic output signal having a predefined frequency, wherein an oscillator voltage is greater than a supply voltage;*

*a microcontroller using the periodic output signal from the oscillator, the microcontroller selectively providing signal output frequencies to a closely spaced array of input touch terminals of a keypad, the input touch terminals comprising first and second input touch terminals;*

*the first and second touch terminals defining areas for an operator to provide an input by proximity and touch; and*

*a detector circuit coupled to said oscillator for receiving said periodic output signal from said oscillator, and coupled to said first and second touch terminals, said detector circuit being responsive to signals from said oscillator via said microcontroller and a presence of an operator's body capacitance to ground coupled to said first and second touch terminals when proximal or touched by the operator to provide a control output signal for actuation of the controlled device, said detector circuit being configured to generate said control output signal when the operator is proximal or touches said second touch terminal after the operator is proximal or touches said first touch terminal.*

3

4

38. The capacitive responsive electronic switching circuit as defined in claim 37, wherein feedback to the operator is provided by an indicator activated by the microcontroller after the operator touches the second touch terminal.

39. The capacitive responsive electronic switching circuit as defined in claim 37,

wherein said detector circuit compares a sensed body capacitance change caused by the body capacitance decreasing a second touch terminal signal on the detector to ground when proximate to the second touch terminal to a threshold level to generate the control output signal, and

wherein feedback to the operator is provided by an indicator activated by the microcontroller after the operator touches the second touch terminal.

\* \* \* \* \*

# EXHIBIT B



**UNITED STATES DEPARTMENT OF COMMERCE  
Patent and Trademark Office**

Address: COMMISSIONER OF PATENTS AND TRADEMARKS  
Washington, D.C. 20231

APPLICATION NO.	FILING DATE	FIRST NAMED INVENTOR	ATTORNEY DOCKET NO.
08/601,268	01/31/96	HOURMAND	B NAR01-P-310

21M1/0422

PRICE HENEVELD COOPER  
DEWITT & LITTON  
695 KENMOOR DRIVE SE  
P O BOX 2567  
GRAND RAPIDS MI 49501

EXAMINER

KAPLAN, J

ART UNIT PAPER NUMBER

2107

8

DATE MAILED: 04/22/97

**Please find below and/or attached an Office communication concerning this application or proceeding.**

**Commissioner of Patents and Trademarks**

# Office Action Summary

Application No. <b>08/601,268</b>	Applicant(s) <b>Hourmand</b>
Examiner <b>Jonathan S. Kaplan</b>	Group Art Unit <b>2107</b>



- Responsive to communication(s) filed on \_\_\_\_\_
- This action is **FINAL**.
- Since this application is in condition for allowance except for formal matters, **prosecution as to the merits is closed** in accordance with the practice under *Ex parte Quayle*, 1935 C.D. 11; 453 O.G. 213.

A shortened statutory period for response to this action is set to expire three month(s), or thirty days, whichever is longer, from the mailing date of this communication. Failure to respond within the period for response will cause the application to become abandoned. (35 U.S.C. § 133). Extensions of time may be obtained under the provisions of 37 CFR 1.136(a).

### Disposition of Claims

- Claim(s) 1-20 is/are pending in the application.  
Of the above, claim(s) \_\_\_\_\_ is/are withdrawn from consideration.
- Claim(s) \_\_\_\_\_ is/are allowed.
- Claim(s) 1-4, 6-14, and 16-20 is/are rejected.
- Claim(s) 5 and 15 is/are objected to.
- Claims \_\_\_\_\_ are subject to restriction or election requirement.

### Application Papers

- See the attached Notice of Draftsperson's Patent Drawing Review, PTO-948.
- The drawing(s) filed on \_\_\_\_\_ is/are objected to by the Examiner.
- The proposed drawing correction, filed on \_\_\_\_\_ is  approved  disapproved.
- The specification is objected to by the Examiner.
- The oath or declaration is objected to by the Examiner.

### Priority under 35 U.S.C. § 119

- Acknowledgement is made of a claim for foreign priority under 35 U.S.C. § 119(a)-(d).
  - All  Some\*  None of the CERTIFIED copies of the priority documents have been
    - received.
    - received in Application No. (Series Code/Serial Number) \_\_\_\_\_
    - received in this national stage application from the International Bureau (PCT Rule 17.2(a)).
- \*Certified copies not received: \_\_\_\_\_
- Acknowledgement is made of a claim for domestic priority under 35 U.S.C. § 119(e).

### Attachment(s)

- Notice of References Cited, PTO-892
- Information Disclosure Statement(s), PTO-1449, Paper No(s). 5 and 6
- Interview Summary, PTO-413
- Notice of Draftsperson's Patent Drawing Review, PTO-948
- Notice of Informal Patent Application, PTO-152

--- SEE OFFICE ACTION ON THE FOLLOWING PAGES ---



Art Unit: 2107

**DETAILED ACTION**

*Claim Rejections - 35 USC § 112*

1. Claims 6, 7, and 16 are rejected under 35 U.S.C. 112, second paragraph, as being indefinite for failing to particularly point out and distinctly claim the subject matter which applicant regards as the invention.

Claims 6 and 16 are vague and indefinite because it is unclear what is meant by "to increase the sensitivity of said charge pump circuit to touching of said touch terminal by an operator's body."

*Claim Rejections - 35 USC § 102*

2. The following is a quotation of the appropriate paragraphs of 35 U.S.C. 102 that form the basis for the rejections under this section made in this Office action:

A person shall be entitled to a patent unless --

(b) the invention was patented or described in a printed publication in this or a foreign country or in public use or on sale in this country, more than one year prior to the date of application for patent in the United States.

3. Claims 1-4 and 12-14 are rejected under 35 U.S.C. 102(b) as being anticipated by Kent. (4,352,141)

Kent discloses a capacitive responsive switching comprising: an oscillator (N5, N6, R1, C1) having a frequency of 1 MHZ, an input touch terminal (3), a detector circuit (E) coupled to said oscillator and said touch input terminal, DC power supply (1), wherein said periodic input signal provided by said oscillator is a square wave see column 2, lines 9-12, and a plurality of

Art Unit: 2107

active elements coupled to an output of said oscillator to buffer and improve the shape of the square wave output therefrom (C3, C4, R2), and a charge pump (D1, N1, R4, and C6).

*Claim Rejections - 35 USC § 103*

4. The following is a quotation of 35 U.S.C. 103(a) which forms the basis for all obviousness rejections set forth in this Office action:

(a) A patent may not be obtained though the invention is not identically disclosed or described as set forth in section 102 of this title, if the differences between the subject matter sought to be patented and the prior art are such that the subject matter as a whole would have been obvious at the time the invention was made to a person having ordinary skill in the art to which said subject matter pertains. Patentability shall not be negated by the manner in which the invention was made.

5. Claims 8-11, 18, and 19 are rejected under 35 U.S.C. 103(a) as being unpatentable over Kent in view of Ingraham (5,087,825).

Claims 8 and 9 add the limitations of a microcontroller. Kent does not disclose the detector circuit including a microcontroller. However, Ingraham discloses a detector circuit including a microcontroller. (80) It would have been obvious to one of ordinary skill in the art to replace the detector circuit of Kent with the detector circuit of Ingraham in order to provide a computerized control circuit that can control a plurality of different load requirements sent by a plurality of touch sensors.

Claims 10 and 11 add the limitations of a plurality of input touch terminals and a plurality of touch circuits. Kent only teaches one touch input terminal and one touch circuitry. However, Ingraham discloses a plurality of input touch terminals (18) with corresponding touch circuits. It would have been obvious to one of ordinary skill in the art at the time the invention was made to

Art Unit: 2107

utilize the teachings of Ingraham into Kent's device for the purpose of providing a plurality of ways in which the load may be controlled see column 2, lines 36-40.

As to claims 18 and 19, Kent discloses a capacitive responsive switching comprising: an oscillator (N5, N6, R1, C1) having a frequency of 1 MHZ, an input touch terminal (3), and a detector circuit (E) coupled to said oscillator and said touch input terminal. Kent only teaches one touch input terminal and one touch circuitry. However, Ingraham discloses a plurality of input touch terminals (18) with corresponding touch circuits. It would have been obvious to one of ordinary skill in the art at the time the invention was made to utilize the teachings of Ingraham into Kent's device for the purpose of providing a plurality of ways in which the load may be controlled see column 2, lines 36-40. Kent also does not disclose the details of the touch input comprising a dielectric substrate. However, Ingraham does disclose a touch sensor comprising a dielectric layer substrate (26). It would have been obvious to one of ordinary skill in the art at the time the invention was made to utilize the teachings of Ingraham into Kent's device as this is a well known way to activate a capacitor switch input.

6. Claims 8-11, 18, and 19 are rejected under 35 U.S.C. 103(a) as being unpatentable over Kent in view of Kirton (5,235,217).

Kent discloses a capacitive responsive switching comprising: an oscillator (N5, N6, R1, C1) having a frequency of 1 MHZ, an input touch terminal (3), and a detector circuit (E) coupled to said oscillator and said touch input terminal.

Art Unit: 2107

Kent does not disclose the shape of the touch terminal. However, Kirton discloses a touch terminal (14) which is domed shaped. It would have been obvious to one of ordinary skill in the art at the time the invention was made to utilize the teachings of Kirton into Kent's device for the purpose of providing a touch sensor which is easy to operate.

7. Claims 5 and 15 are objected to as being dependent upon a rejected base claim, but would be allowable if rewritten in independent form including all of the limitations of the base claim and any intervening claims.

8. Claims 6, 7, and 16 would be allowable if rewritten to overcome the rejection(s) under 35 U.S.C. 112 set forth in this Office action and to include all of the limitations of the base claim and any intervening claims.

Any inquiry concerning this communication or earlier communications from the examiner should be directed to Jonathan S. Kaplan whose telephone number is (703) 308-1216.

Any inquiry of a general nature or relating to the status of this application should be directed to the Group receptionist whose telephone number is (703) 308-1782.

  
JSK  
April 11, 1997

  
WILLIAM M. CHOOFAN  
SUPERVISORY PATENT EXAMINER  
ART UNIT 217

**Notice of References Cited**

Application No.  
08/601,268

Applicant(s)

Hourmand

Examiner  
Jonathan S. Kaplan

Group Art Unit  
2107

Page 1 of 1

**U.S. PATENT DOCUMENTS**

	DOCUMENT NO.	DATE	NAME	CLASS	SUBCLASS
A	<del>999,533,621</del> 4,352,141	8/1993	Kirton	307	326
B	4,352,141	9/1982	Kent	363	181
C					
D					
E					
F					
G					
H					
I					
J					
K					
L					
M					

**FOREIGN PATENT DOCUMENTS**

	DOCUMENT NO.	DATE	COUNTRY	NAME	CLASS	SUBCLASS
N						
O						
P						
Q						
R						
S						
T						

**NON-PATENT DOCUMENTS**

	DOCUMENT (Including Author, Title, Source, and Pertinent Pages)	DATE
U		
V		
W		
X		

**NOTICE OF DRAFTSPERSON'S PATENT DRAWING REVIEW**

PTO Draftpersons review all originally filed drawings regardless of whether they are designated as formal or informal. Additionally, patent Examiners will review the drawings for compliance with the regulations. Direct telephone inquiries concerning this review to the Drawing Review Branch, 703-305-8404.

The drawings filed (insert date) 1/31/96 are

A.  not objected to by the Draftsperson under 37 CFR 1.84 or 1.152.

B.  objected to by the Draftsperson under 37 CFR 1.84 or 1.152 as indicated below. The Examiner will require submission of new, corrected drawings when necessary. Corrected drawings must be submitted according to the instructions on the back of this Notice.

- DRAWINGS.** 37 CFR 1.84(a): Acceptable categories of drawings:
  - Black ink. Color.
  - Not black solid lines. Fig(s) \_\_\_\_\_
  - Color drawings are not acceptable until petition is granted. Fig(s) \_\_\_\_\_
- PHOTOGRAPHS.** 37 CFR 1.84(b)
  - Photographs are not acceptable until petition is granted. Fig(s) \_\_\_\_\_
  - Photographs not properly mounted (must use brylston board or photographic double-weight paper). Fig(s) \_\_\_\_\_
  - Poor quality (half-tone). Fig(s) \_\_\_\_\_
- GRAPHIC FORMS.** 37 CFR 1.84 (d)
  - Chemical or mathematical formula not labeled as separate figure. Fig(s) \_\_\_\_\_
  - Group of waveforms not presented as a single figure, using common vertical axis with time extending along horizontal axis. Fig(s) \_\_\_\_\_
  - Individuals waveform not identified with a separate letter designation adjacent to the vertical axis. Fig(s) \_\_\_\_\_
- TYPE OF PAPER.** 37 CFR 1.84(c)
  - Paper not flexible, strong, white, smooth, nonshiny, and durable. Sheet(s) \_\_\_\_\_
  - Erasures, alterations, overwritings, interlineations, tracks, creases, and folds copy machine-made not accepted. Fig(s) 1-200
  - Mylar, vellum paper is not acceptable (too thin). Fig(s) \_\_\_\_\_
- SIZE OF PAPER.** 37 CFR 1.84(f): Acceptable sizes:
  - 21.6 cm. by 35.6 cm. (8 1/2 by 14 inches)
  - 21.6 cm. by 33.1 cm. (8 1/2 by 13 inches)
  - 21.6 cm. by 27.9 cm. (8 1/2 by 11 inches)
  - 21.0 cm. by 29.7 cm. (DIN size A4)
  - All drawing sheets not the same size. Sheet(s) \_\_\_\_\_
  - Drawing sheet not an acceptable size. Sheet(s) \_\_\_\_\_
- MARGINS.** 37 CFR 1.84(g): Acceptable margins:
 

Paper size			
21.6 cm. X 35.6 cm. (8 1/2 X 14 inches)	21.6 cm. X 33.1 cm. (8 1/2 X 13 inches)	21.6 cm. X 27.9 cm. (8 1/2 X 11 inches)	21.0 cm. X 29.7 cm. (DIN Size A4)
T 5.1 cm. (2")	2.5 cm. (1")	2.5 cm. (1")	2.5 cm.
L .64 cm. (1/4")	.64 cm. (1/4")	.64 cm. (1/4")	2.5 cm.
R .64 cm. (1/4")	.64 cm. (1/4")	.64 cm. (1/4")	1.5 cm.
B .64 cm. (1/4")	.64 cm. (1/4")	.64 cm. (1/4")	1.0 cm.

Margins do not conform to those above.

Sheet(s) 5, 12, 13, 15A, 17

Top (T) \_\_\_\_\_ Left (L) \_\_\_\_\_ Right (R) \_\_\_\_\_ Bottom (B) \_\_\_\_\_
- VIEWS.** 37 CFR 1.84(h)
  - REMINDER: Specification may require revision to correspond to drawing changes.
  - All views not grouped together. Fig(s) \_\_\_\_\_
  - Views connected by projection lines or lead lines. Fig(s) \_\_\_\_\_
  - Partial views. 37 CFR 1.84(h) 2
- VIEW AND ENLARGED VIEW NOT LABELED SEPARATELY OR PROPERLY.** Fig(s) \_\_\_\_\_
- SECTIONAL VIEWS.** 37 CFR 1.84 (h) 3
  - Hatching not indicated for sectional portions of an object. Fig(s) \_\_\_\_\_
  - Cross section not drawn same as view with parts in cross section with regularly spaced parallel oblique strokes. Fig(s) \_\_\_\_\_
- ARRANGEMENT OF VIEWS.** 37 CFR 1.84(i)
  - Words do not appear on a horizontal, left-to-right fashion when page is either upright or turned so that the top becomes the right side, except for graphs. Fig(s) \_\_\_\_\_
- SCALE.** 37 CFR 1.84(k)
  - Scale not large enough to show mechanism with crowding when drawing is reduced in size to two-thirds in reproduction. Fig(s) \_\_\_\_\_
  - Indication such as "actual size" or scale 1/2" not permitted. Fig(s) \_\_\_\_\_
- CHARACTER OF LINES, NUMBERS, & LETTERS.** 37 CFR 1.84(l)
  - Lines, numbers & letters not uniformly thick and well defined, clean, durable, and black (except for color drawings). Fig(s) 1-200
- SHADING.** 37 CFR 1.84(m)
  - Solid black shading areas not permitted. Fig(s) \_\_\_\_\_
  - Shade lines, pale, rough and blurred. Fig(s) \_\_\_\_\_
- NUMBERS, LETTERS, & REFERENCE CHARACTERS.** 37 CFR 1.84(p)
  - Numbers and reference characters not plain and legible. 37 CFR 1.84(p)(1) Fig(s) 1-200
  - Numbers and reference characters not oriented in same direction as the view. 37 CFR 1.84(p)(1) Fig(s) \_\_\_\_\_
  - English alphabet not used. 37 CFR 1.84(p)(2) Fig(s) \_\_\_\_\_
  - Numbers, letters, and reference characters do not measure at least .32 cm. (1/8 inch) in height. 37 CFR(p)(3) Fig(s) 5A
- LEAD LINES.** 37 CFR 1.84(q)
  - Lead lines cross each other. Fig(s) \_\_\_\_\_
  - Lead lines missing. Fig(s) \_\_\_\_\_
- NUMBERING OF SHEETS OF DRAWINGS.** 37 CFR 1.84(i)
  - Sheets not numbered consecutively, and in Arabic numerals, beginning with number 1. Sheet(s) \_\_\_\_\_
- NUMBER OF VIEWS.** 37 CFR 1.84(u)
  - Views not numbered consecutively, and in Arabic numerals, beginning with number 1. Fig(s) \_\_\_\_\_
  - View numbers not preceded by the abbreviation Fig. Fig(s) \_\_\_\_\_
- CORRECTIONS.** 37 CFR 1.84(w)
  - Corrections not made from prior PTO-948. Fig(s) \_\_\_\_\_
- DESIGN DRAWING.** 37 CFR 1.152
  - Surface shading shown not appropriate. Fig(s) \_\_\_\_\_
  - Solid black shading not used for color contrast. Fig(s) \_\_\_\_\_

COMMENTS:

ATTACHMENT TO PAPER NO. 8

REVIEWER 902

DATE 2/1/96

PTO Copy



Form PTO-1449

U.S. DEPARTMENT OF COMMERCE  
PATENT AND TRADEMARK OFFICE

ATTY. DOCKET NO.  
**NAR01 P-310**

SERIAL NO.  
**05/601,268**

**INFORMATION DISCLOSURE STATEMENT  
BY APPLICANT**

APPLICANTS  
**Byron Hourmand**

FILING DATE: \_\_\_\_\_ GROUP: \_\_\_\_\_

**U.S. PATENT DOCUMENTS**

EXAMINER INITIAL	PATENT NUMBER								ISSUE DATE	NAME	CLASS	SUBCLASS	FILING DATE IF APPROPRIATE
	5	4	5	3	6	4	4	9					
OK [Signature]	5	4	5	3	6	4	4	09/26/95	Yap et al.				
	5	3	8	6	2	1	9	01/31/95	Greanias et al.				
	5	2	3	5	2	1	7	08/10/93	Kirton				
	5	2	3	3	2	3	1	08/03/93	Wieth et al.				
	5	2	0	8	5	1	6	05/04/93	Saidian				
	5	0	8	7	8	2	5	02/11/92	Ingraham				
	5	0	6	6	8	9	8	11/19/91	Miller et al.				
	5	0	1	2	1	2	4	04/30/91	Hollaway				
	4	9	3	9	3	8	2	07/03/90	Gruodis				
	4	9	1	0	5	0	4	03/20/90	Eriksson				
	4	8	3	1	2	7	9	05/16/89	Ingraham				
	4	7	5	8	7	3	5	07/19/88	Ingraham				
	4	7	3	1	5	4	8	03/15/88	Ingraham				
	4	4	7	6	4	6	3	10/09/84	Ng et al.				
	4	3	7	4	3	8	1	02/15/83	Ng et al.				
	4	3	6	0	7	3	7	11/23/82	Leopold				
	4	3	2	3	8	2	9	04/06/82	Witney et al.				
	4	3	0	8	4	4	3	12/29/81	Tucker et al.				
4	2	8	9	9	8	0	09/15/81	McLaughlin					
4	2	8	9	9	7	2	09/15/81	Wern					
4	2	6	4	8	3	1	04/28/81	Wern					
4	2	5	7	1	1	7	03/17/81	Besson					

**FOREIGN PATENT DOCUMENTS**

DOCUMENT NUMBER	PUBLICATION DATE	COUNTRY	CLASS	SUBCLASS	TRANSLATION	
					YES	NO

**OTHER DOCUMENTS (Including Author, Title, Date, Pertinent Pages, Etc.)**

--	--	--	--	--	--

EXAMINER: Jonathan Kaplan

DATE CONSIDERED: 4/11/97

EXAMINER: Initial if citation is considered, whether or not citation is in conformance with MPEP 609; Draw line through citation if not in conformance and not considered. Include copy of this form with next communication to applicant.



Form PTO-1449

U.S. DEPARTMENT OF COMMERCE  
PATENT AND TRADEMARK OFFICE

ATTY. DOCKET NO.

SERIAL NO.

NAR01 P-310

08/601268

INFORMATION DISCLOSURE STATEMENT  
BY APPLICANT

APPLICANTS

Byron Hourmand

FILING DATE

GROUP

U.S. PATENT DOCUMENTS

EXAMINER INITIAL	PATENT NUMBER								ISSUE DATE	NAME	CLASS	SUBCLASS	FILING DATE IF APPROPRIATE
	4	2	4	6	5	3	3						
OK	4	2	4	6	5	3	3	01/20/81	Chiang				
	4	2	3	7	4	2	1	12/02/80	Waldron				
	4	2	2	0	8	1	5	09/02/80	Gibson et al.				
	4	2	1	3	0	6	1	07/15/80	Conner				
	4	2	1	1	9	5	9	07/08/80	Deavenport et al.				
	4	2	1	0	8	2	2	07/01/80	Wern				
	4	1	5	9	4	7	3	06/26/79	Senk				
	4	1	5	2	6	2	9	05/01/79	Raupp				
	4	1	1	9	8	6	4	10/10/78	Petrizio				
	4	1	0	1	8	0	5	07/18/78	Stone				
	4	0	7	1	6	8	9	01/31/78	Talmage et al.				
	4	0	3	1	4	0	8	06/21/77	Holz				
	4	0	1	6	4	5	3	04/05/77	Moennig				
	3	9	8	4	7	5	7	10/05/76	Gott et al.				
	3	9	6	5	4	6	5	06/22/76	Alexander				
	3	9	1	9	5	9	6	11/11/75	Bellis				
	3	9	1	1	2	1	5	10/07/75	Hurst et al.				
	3	8	9	9	7	1	3	08/12/75	Barkan et al.				
	3	7	9	8	3	7	0	03/19/74	Hurst				
	3	6	6	6	9	8	8	05/30/72	Bellis				
3	6	5	1	3	9	1	03/21/72	Vogelsberg					
3	6	4	1	4	1	0	02/08/72	Vogelsberg					
3	5	4	9	9	0	9	08/25/69	Adelson et al.					

FOREIGN PATENT DOCUMENTS

DOCUMENT NUMBER	PUBLICATION DATE	COUNTRY	CLASS	SUBCLASS	TRANSLATION	
					YES	NO

OTHER DOCUMENTS (Including Author, Title, Date, Pertinent Pages, Etc.)

--	--	--

EXAMINER

Jonathan Kaplan

DATE CONSIDERED

4/11/97

EXAMINER: Initial if citation is considered, whether or not citation is in conformance with MPEP 609; Draw line through citation if not in conformance and not considered. Include copy of this form with next communication to applicant.



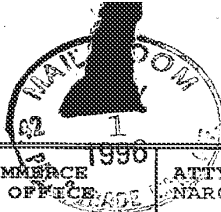

5/1/96

Sheet 1 of 1

FORM PTO-1449 U.S. DEPARTMENT OF COMMERCE (Rev. 2-32) PATENT AND TRADEMARK OFFICE  INFORMATION DISCLOSURE STATEMENT BY APPLICANT  (Use several sheets if necessary)	ATTY. DOCKET NO. MAR01 P-310	SERIAL NO. 08/601,268 (unofficial)
	APPLICANT(S) Byron Hourmand	
	FILING DATE 01/31/96	GROUP

U.S. PATENT DOCUMENTS

EXAMINER INITIAL	DOCUMENT NUMBER								DATE	NAME	CLASS	SUB-CLASS	FILING DATE IF APPROPRIATE
	3	8	7	9	6	1	8						
[Handwritten Initials]	3	8	7	9	6	1	8	04/22/75	Larson	367	116		
	4	5	0	3	2	9	4	03/05/85	Matsumaru	800	5A		
	4	9	4	2	6	3	1	07/24/90	Rosa	4	623		

FOREIGN PATENT DOCUMENTS

EXAMINER INITIAL	DOCUMENT NUMBER								DATE	COUNTRY	CLASS	SUB-CLASS	TRANSLATION	
	3	8	7	9	6	1	8						Y	N

OTHER DOCUMENTS (Including Author, Title, Date, Pertinent Pages, Etc.)

EXAMINER INITIAL	DOCUMENT NUMBER	DATE	OTHER INFORMATION

EXAMINER	Jonathan Kaplan	DATE CONSIDERED	4/11/97
EXAMINER: Initial if citation considered, whether or not citation is in conformance with MPEP 609; Draw line through citation if not in conformance and not considered. Include copy of this form with next communication to applicant.			

(Form PTO-1449 [6-4])



Atty. Docket No. NAR01 P-310

IN THE UNITED STATES PATENT AND TRADEMARK OFFICE

Art Unit : 2107  
Examiner : J. Kaplan  
Appln. No. : 08/601,268  
Filing Date : January 31, 1996  
Applicant : Byron Hourmand  
For : CAPACITIVE RESPONSIVE ELECTRONIC SWITCHING CIRCUIT

# 10

Assistant Commissioner for Patents  
Washington, D.C. 20231

RECEIVED  
SEP 22 1997  
GROUP 2100

Dear Sir:

AMENDMENT

This is a response to the Office Action mailed April 22, 1997. The time for filing a response to the Office Action has been extended by the petition for a one-month extension of time and payment of the appropriate fee filed concurrently with this amendment. Applicant requests that the Examiner amend the above-captioned application as follows.

In the Drawings:

Subject to the approval of the Examiner, please amend Figs. 1, 3, 4, 5, 11, 12, 13, 14, and 18 as shown in red on the attached sheets of drawings.

In the Specification:

Please amend the specification as follows:

- Page 1, line 9, change "movement" to --movements--.
- Page 2, line 17, after "is" insert --(are)--.
- Page 12, line 1, change "ground" to --common--.
- Page 12, line 5, change "approved" to --listed--.
- Page 12, line 9, change "ground" to --floating common--.
- Page 12, line 12, delete "true".

Applicant : Byron Hourmand  
Appl. No. : 08/601,268  
Page : 2

- ✓ Page 13, line 19, after "operator" insert --to--.
- ✓ Page 14, line 2, after "capacitance" insert --to ground--.
- ✓ Page 15, line 2, change "ground" to --common--.
- ✓ Page 17, line 9, change "an external" to --a--.
- ✓ Page 17, line 12, change "ZB" to --Z<sub>B</sub>--.
- ✓ Page 18, line 11, change "ZW" to --Z<sub>W</sub>--.
- ✓ Page 21, line 11, change "an external" to --a--.
- ✓ Page 21, line 16, change "it's" to --its--.
- ✓ Page 23, line 12, change "will" to --well--.
- ✓ Page 23, line 20, delete "preferably".
- ✓ Page 25, line 7, delete "relative to an external ground such as the earth".
- ✓ Page 26, line 4, change "ground" to --common--.
- ✓ Page 26, line 6, change "ground" to --common--.
- ✓ Page 26, line 7, change "ground" to --common--.
- ✓ Page 26, line 9, change "ground" to --common--.
- ✓ Page 26, line 10, change "ground" to --common-- (both occurrences).
- ✓ Page 26, line 12, change "ground" to --common--.
- ✓ Page 26, line 14, after "capacitance" insert --to ground--.
- ✓ Page 26, line 17, after "capacitance" insert --to ground--.
- ✓ Page 29, line 13, change "coupled" to --directly connected--.
- ✓ Page 29, line 14, change "coupled" to --directly connected--.

Applicant : Byron Hourmand  
Appl. No. : 08/601,268  
Page : 3

Page 29, line 14, delete "output of the".

Page 29, line 14, change "213" to --216--.

Page 30, line 8, after "between" insert --near to--.

Page 30, line 15, change "generate" to --the floating common generator 300 such that

*a'* together they supply a--.

Page 30, line 16, change "and powers up" to --to power--.

Page 30, line 16, change "circuits" to --circuit(s)--.

Page 31, line 4, change "must" to --can--.

Page 31, line 6, delete "and preferably".

Page 31, line 17, delete "between the".

Page 31, line 18, delete "collector of transistor 410 and floating ground line 301".

Page 32, line 11, after "includes" insert --resistor 412 and--.

Page 32, line 12, before "resistor" insert --to--.

Page 32, line 16, change "Resistor 413 is used to limit the base current." to --The

*a2* base of transistor 410 is connected via resistor 413 to line 451 connected to touch pad 450.--.

Page 33, line 5, after "capacitance" insert --to ground--.

Page 33, line 11, after "capacitance" insert --to ground--.

Page 33, line 11, delete "earth".

Page 33, line 15, after "reverse" insert --bias--.

Page 33, line 15, change "thereby reducing" to --and also reduce--.

Page 40, line 11, after "length" insert --451--.

Applicant : Byron Hourmand  
Appl. No. : 08/601,268  
Page : 4

- Page 40, line 11, change "pad 451" to --pad 450--.
- Page 41, line 9, change "and an earth relative ground" to --with ground connection--.
- Page 41, line 10, after "1103," delete "and".
- Page 42, line 9, change "to relative earth ground 1103" to --via line 1103 to ground--.
- Page 42, line 17, change "power line" to --power common line--.
- Page 42, line 17, delete "relative".
- Page 44, line 8, change "a transistor" to --a bipolar PNP transistor--.
- Page 44, line 8, change "1420" to --1420a--.
- Page 44, line 9, change "power line" to --power common line--.
- Page 44, line 18, change "1424" to --1424a--.
- Page 45, line 2, change "power line" to --power common line--.
- Page 45, line 4, change "negative" to --inverting input--.
- Page 45, line 4, change "positive" to --non-inverting input--.
- Page 45, line 11, change "power line" to --power common line--.
- Page 45, line 12, after "base of" insert --bipolar PNP--.
- Page 45, line 13, change "power line" to --power common line--.
- Page 46, line 4, change "power line" to --power common line--.
- Page 46, line 5, change "negative" to --inverting input--.
- Page 46, line 6, change "positive" to --non-inverting input--.
- Page 46, line 7, change "positive" to --non-inverting input--.
- Page 46, line 8, change "power line" to --power common line--.

Applicant : Byron Hourmand  
Appl. No. : 08/601,268  
Page : 5

- Page 46, line 10, change "1639" to --1630--.
- Page 46, line 11, change "positive" to --non-inverting--.
- Page 46, line 12, change "invertor gate" to --invertor NAND gate--.
- Page 46, line 14, change "invertor gate" to --invertor NAND gate--.
- Page 46, line 15, change "invertor gate" to --invertor NAND gate-- (both occurrences).
- Page 46, line 15, change "power line" to --power common line--.
- Page 46, line 16, after "switching" insert --bipolar PNP--.
- Page 46, line 17, change "power line" to --power common line--.
- Page 47, line 15, change "(1628)" to --(invertor NAND gate 1628)--.
- Page 47, line 17, change "(1536)" to --(1636)--.
- Page 47, line 18, after "when" insert --the--.
- Page 47, line 19, change "button" to --touch terminal--.
- Page 48, line 15, after "one" insert --of the touch switch circuits--.
- Page 48, line 15, after "redundant" insert --relay driver--.
- Page 48, line 16, after "one" insert --of the driver circuits--.
- Page 48, line 20, change "2201" to --2205. Palm button 2201--.
- Page 49, line 1, delete "second" (first occurrence).
- Page 50, line 6, change "sid" to --side--.
- Page 51, line 4, after "smaller" insert --series--.
- Page 51, line 6, after "body" insert --to ground-- (both occurrences).

Applicant : Byron Hourmand  
Appl. No. : 08/601,268  
Page : 6

Page 51, line 8, after "capacitance" insert --to ground--.

Page 51, line 10, change "earth" to --ground--.

Page 53, line 1, change "decrease and increase" to --adjust--.

Page 53, line 2, delete "respectively".

Page 53, line 5, after "200" insert --(Fig. 6)-- (first occurrence).

Page 53, line 10, change "pulls" to --sources--.

In the Abstract:

Please amend the abstract as follows:

Line 6, before "touch" insert --proximity and--.

Line 9, after "capacitance" insert --to ground--.

Line 9, after "when" insert --in proximity or--.

In the Claims:

Please amend claims 1, 3, 5, 6, 12-18, and 20, and add new claims 21-32 as follows:

1. (Amended) A capacitive responsive electronic switching circuit comprising:

an oscillator providing a periodic output signal having a frequency of 50 kHz or greater;

an input touch terminal having a dielectric cover defining an area for an operator to provide an input by proximity and touch, an operator's body capacitance to ground as sensed through said input touch terminal varying as a function of the area of said input touch terminal that is proximate the operator's body; and

Applicant : Byron Hourmand  
Appl. No. : 08/601,268  
Page : 7

AP  
Cmd

a detector circuit coupled to said oscillator for receiving said periodic output signal from said oscillator, and coupled to said input touch terminal, said detector circuit being responsive to signals from said oscillator and the presence of an operator's body capacitance to ground coupled to said touch terminal when proximal or touched by an operator to provide a control output signal, wherein said detector circuit includes means for generating said control signal when the sensed body capacitance to ground exceeds a threshold level in order to prevent unintended activation based upon an operator's inadvertent proximity and touch with said input touch terminal.

---

[

Claim 3, line 2, delete "reference to an external".

---

9. → (Amended) A capacitive responsive electronic [The] switching circuit [as defined in claim 1 and further including] comprising:

AY

an oscillator providing a periodic output signal having a frequency of 50 kHz or greater;

an input touch terminal defining an area for an operator to provide an input by proximity and touch;

a detector circuit coupled to said oscillator for receiving said periodic output signal from said oscillator, and coupled to said input touch terminal, said detector circuit being responsive to signals from said oscillator and the presence of an operator's body capacitance



Applicant : Byron Hourmand  
Appl. No. : 08/601,268  
Page : 8

to ground coupled to said touch terminal when proximal or touched by an operator to provide a control output signal; and

a floating [ground] common generator coupled to said oscillator for receiving said square wave output signal, said floating [ground] common generator generating a floating [ground] common reference for said detector circuit that is set at a fixed voltage below and tracks the square wave output signal.

*Amid.* 10. ~~6.~~ (Amended) The switching circuit as defined in claim ~~5~~<sup>9</sup>, wherein said detector circuit is powered by said square wave output signal provided by said oscillator and by said floating [ground] common reference provided by said floating [ground] common generator [to increase] thereby increasing the sensitivity of said detector circuit to proximity and touching of said touch terminal by an operator's body.

---

12. (Amended) A proximity and touch controlled switching circuit comprising:

*Q5* an oscillator providing a square wave output signal having a frequency of 50 kHz or greater;

a touch terminal having a dielectric cover defining an input terminal for coupling to an operator's body capacitance to ground; and

a charge pump circuit coupled to said oscillator for receiving said square wave output signal, and coupled to said touch terminal, said charge pump circuit having an output terminal that supplies an output signal having a voltage that varies when said touch terminal

Applicant : Byron Hourmand  
Appl. No. : 08/601,268  
Page : 9

is proximal or touched by an operator's body, the voltage of said output signal varies as a function of the area of said touch terminal that is proximal or touched by an operator,

wherein said charge pump circuit includes at least one high speed diode coupled between said oscillator and said touch terminal, for enhancing a sensitivity at which said charge pump responds to sensed body capacitance to ground at said touch terminal for higher frequencies.

AS  
cond.

13. (Amended) The [touch control] proximity and touch controlled circuit as defined in claim 12 and further including a DC power supply for supplying power to said oscillator and a [reference to an external] ground.

[

Claim 14, line 1, change "touch control" to --proximity and touch controlled--.

16.

~~15.~~ (Amended) A proximity and [The] touch [control] controlled switching circuit [as defined in claim 12 and further including] comprising:

an oscillator providing a square wave output signal having a frequency of 50 kHz or greater;

a touch terminal defining an input terminal for coupling to an operator's body capacitance to ground;

a charge pump circuit coupled to said oscillator for receiving said square wave output signal, and coupled to said touch terminal, said charge pump circuit having an output

Ab

64

Applicant : Byron Hourmand  
Appl. No. : 08/601,268  
Page : 10

terminal that supplies an output signal having a voltage that varies when said touch terminal is proximal or touched by an operator's body; and

a floating [ground] common generator coupled to said oscillator for receiving said square wave output signal, said floating [ground] common generator generating a floating [ground] common reference for said charge pump circuit that is set at a fixed voltage below and tracks said square wave output signal,

wherein said charge pump circuit includes at least one high speed diode coupled between said oscillator and said touch terminal, for enhancing a sensitivity at which said charge pump responds to sensed body capacitance to ground at said touch terminal for higher frequencies.

Ab  
omit.

17. <sup>16</sup>  
~~16.~~ (Amended) The proximity and touch [control] controlled circuit as defined in claim ~~15~~,  
wherein said charge pump circuit is powered by said square wave output signal provided by said oscillator and by said floating [ground] common reference provided by said floating [ground] common generator [to increase] thereby increasing the sensitivity of said charge pump circuit to proximity and touching of said touch terminal by an operator's body.

[

Claim 17, line 1, change " touch control" to --proximity and touch controlled--.

65

Applicant : Byron Hourmand  
Appl. No. : 08/601,268  
Page : 11

---

18. (Amended) A capacitive responsive electronic switching circuit comprising:

an oscillator providing a periodic output signal having a predefined frequency;

a plurality of input touch terminals defining adjacent areas on a dielectric substrate for an operator to provide inputs by proximity and touch; and

MB  
AT  
a detector circuit coupled to said oscillator for receiving said periodic output signal from said oscillator, and coupled to said input touch terminals, said detector circuit being responsive to signals from said oscillator and the presence of an operator's body capacitance to ground coupled said touch terminals when proximal or touched by an operator to provide a control output signal,

wherein said predefined frequency of said oscillator is selected to decrease the impedance of said dielectric substrate relative to the impedance of any contaminate that may create an electrical on said dielectric substrate path between said adjacent areas, and wherein said detector circuit compares the sensed body capacitance to ground proximate an input touch terminal to a threshold level to prevent inadvertent generation of the control output signal.

---

AS  
20. (Amended) A capacitive responsive electronic switching circuit comprising:

an oscillator providing a periodic output signal having a predefined frequency;

a dome-shaped touch terminal defining an area for an operator to provide an input by proximity and touch, wherein the dome shape of the touch terminal is constructed to ergonomically fit the palm of a human hand; and

Applicant : Byron Hourmand  
Appl. No. : 08/601,268  
Page : 12

As  
am

a detector circuit coupled to said oscillator for receiving said periodic output signal from said oscillator, and coupled to said [input] touch terminal [terminals], said detector circuit being responsive to signals from said oscillator and the presence of an operator's body capacitance to ground coupled to said touch [terminals] terminal when proximal or touched by an operator to provide a control output signal, said detector circuit including means for discriminating between a proximity and touch of said dome-shaped touch terminal by the palm of a human hand and a proximity and touch by a human finger.

---

21. (New) A capacitive responsive electronic switching circuit comprising:

an oscillator providing a periodic output signal having a predefined frequency;

a touch terminal defining an area for an operator to provide an input by proximity and touch; and

a<sup>9</sup>  
a detector circuit coupled to said oscillator for receiving said periodic output signal from said oscillator, and coupled to said touch terminal, said detector circuit being responsive to signals from said oscillator and the presence of an operator's body capacitance to ground coupled to said touch terminal when proximal or touched by an operator to provide a control output signal, said detector circuit including discriminating means for discriminating between a proximity and touch of said touch terminal covering substantially all of said area of said touch terminal and a proximity and touch covering less than substantially all of said area of said touch terminal.

Applicant : Byron Hourmand  
Appl. No. : 08/601,268  
Page : 13

22. (New) The switching circuit as defined in claim 21, wherein said touch terminal includes a dome-shaped dielectric cover.

23. (New) The switching circuit as defined in claim 21, wherein said touch terminal includes a palm-sized dielectric cover.

24. (New) The switching circuit as defined in claim 23, wherein said discriminating means determines that a proximity and touch of said touch terminal covers substantially all of said area of said touch terminal when said dielectric cover is proximal or touched with the palm of an operator's hand and determines that a proximity or touch covers less than substantially all of said area of said touch terminal when said dielectric cover is proximal or touched with one of an operator's fingers.

25. (New) The switching circuit as defined in claim 21, wherein said discriminating means discriminates between a proximity and touch of said touch terminal covering substantially all of said area of said touch terminal and a proximity and touch covering less than substantially all of said area of said touch terminal based upon a sensed level of body capacitance to ground proximate said touch terminal.

CG  
Comit.

WS

Applicant : Byron Hourmand  
Appln. No. : 08/601,268  
Page : 14

26. (New) The switching circuit as defined in claim 21, wherein said coupling of capacitance to ground occurs when an operator's body is proximate, but not touching, said touch terminal.

27. (New) A capacitive responsive electronic switching circuit for a controlled device comprising:

an oscillator providing a periodic output signal having a predefined frequency;  
first and second touch terminals defining areas for an operator to provide an input by proximity and touch; and

a detector circuit coupled to said oscillator for receiving said periodic output signal from said oscillator, and coupled to said first and second touch terminals, said detector circuit being responsive to signals from said oscillator and the presence of an operator's body capacitance to ground coupled to said first and second touch terminals when proximal or touched by an operator to provide a control output signal for actuation of the controlled device, said detector circuit being configured to generate said control output signal when said an operator is proximal or touches said second touch terminal after the operator is proximal or touches said first touch terminal.

28. (New) The capacitive responsive electronic switching circuit as defined in claim 27, wherein said detector circuit generates said control signal only when an operator is proximal

69  
Cont.

✓

69

Applicant : Byron Hourmand  
Appl. No. : 08/601,268  
Page : 15

or touches said second touch terminal within a predetermined time period after the operator is proximal or touches said first touch terminal.

29. (New) The capacitive responsive electronic switching circuit as defined in claim 27, wherein said first and second touch terminals are adapted to be mounted on different surfaces of the controlled device.

29  
Cont.  
30. (New) The capacitive responsive electronic switching circuit as defined in claim 27, wherein said first and second touch terminals are adapted to be mounted on non-parallel planar surfaces of the controlled device.

31. (New) The capacitive responsive electronic switching circuit as defined in claim 27, wherein said first and second touch terminals are adapted to be mounted on perpendicular planar surfaces of the controlled device.

32. (New) The capacitive responsive electronic switching circuit as defined in claim 27 and further including an indicator for indicating when said detector circuit determines that an operator is proximal or touches said first touch terminal.

---



Applicant : Byron Hourmand  
Appl. No. : 08/601,268  
Page : 16

#### REMARKS

In the Office Action, the Examiner indicated that claims 5 and 15 would be allowed if rewritten in independent form including all the limitations of the base claim and any intervening claims, and that claims 6, 7, and 16 would also be allowed if rewritten to overcome the rejection under 35 U.S.C. §112. Applicant wishes to thank the Examiner for the early indication of allowable subject matter. By this amendment, Applicant has amended claims 5 and 15 by rewriting them in independent form and by amending claims 6 and 16 to overcome the rejection under 35 U.S.C. §112. Therefore, claims 5-7, 15, and 16 are in condition for allowance.

In the Office Action, the Examiner rejected claims 6, 7, and 16 under 35 U.S.C. §112, second paragraph; rejected claims 1-4 and 12-14 under 35 U.S.C. §102(b) as being anticipated by U.S. Patent No. 4,352,141 issued to Kent; rejected claims 8-11, 18, and 19 under 35 U.S.C. §103 as being unpatentable over Kent in view of U.S. Patent No. 5,087,825 issued to Ingraham; and rejected claims 8-11, 18, and 19 under 35 U.S.C. §103 as being unpatentable over Kent in view of U.S. Patent No. 5,235,217 issued to Kirton.

By this amendment, Applicant has amended claims 1, 5, 6, 12-18, and 20 to more clearly define the present invention, and has added new claims 21-32 to define additional features of the present invention. Accordingly, claims 1-32 are now pending.

With respect to the rejection of claims 6, 7, and 16 under 35 U.S.C. §112, second paragraph, Applicant has amended claims 6 and 16 to more clearly recite the present

Applicant : Byron Hourmand  
Appl. No. : 08/601,268  
Page : 17

invention. Applicant submits that amended claims 6, 7, and 16 meet the requirements of 35 U.S.C. §112, second paragraph.

Applicant respectfully traverses the rejection of claims 1-4 and 12-14 under 35 U.S.C. §102(b) as being anticipated by Kent. As pointed out on page 51 of the present specification, the present invention provides a mechanism by which the touch control circuit can discriminate between an intentional touching of the touch terminal and an inadvertent contact by the operator. Specifically, when the touch terminal is palm-sized and includes a dielectric cover, users may intentionally touch the touch terminal by placing their palm over the entire surface of the touch terminal. When the operator touches the touch terminal in this manner, the touch control circuit of the present invention generates a control signal. On the other hand, if the operator inadvertently touches the touch terminal with one or two fingers, the touch control circuit of the present invention senses a lower body capacitance in the proximity of the touch terminal and thereby determines that the touch was unintentional and thus does not generate the control signal.

As amended, independent claim 1 recites a capacitive response electronic switching circuit comprising a combination of elements including at least "an input touch terminal having a dielectric cover defining an area for an operator to provide an input by touch, an operator's body capacitance as sensed through said input touch terminal varying as a function of the area of said input touch terminal that is proximate the operator's body," and a detector circuit that "includes means for generating said control signal when the sensed body

Applicant : Byron Hourmand  
Appln. No. : 08/601,268  
Page : 18

capacitance exceeds a threshold level in order to prevent unintended activation based upon an operator's inadvertent contact with said input touch terminal."

The Kent patent discloses a touch switch device that also generates the control signal in response to the touching of a touch terminal. The Kent patent, however, fails to teach or suggest a capacitive responsive electronic switching circuit having a detector circuit that includes means for generating a control signal when the sensed body capacitance exceeds a threshold level in order to prevent unintended activation based upon an operator's inadvertent contact with the input touch terminal. Thus, the Kent patent does not anticipate nor render obvious the invention as defined in independent claim 1. Clearly, the Kent patent does not disclose any way of discriminating between a partial touch and a full touch of the touch terminal.

With respect to independent claim 12, the Kent patent fails to teach or suggest a touch-controlled switching circuit comprising a charge pump circuit that supplies an output signal having a voltage that varies as a function of the area of the touch terminal that is touched by an operator. Therefore, the Kent patent fails to teach or suggest each and every element recited in independent claim 12.

For these reasons, independent claims 1 and 12, as well as claims 2-4, 13, and 14 which depend therefrom, are allowable over the Kent patent.

Applicant respectfully traverses the rejection of claims 8-11, 18, and 19 under 35 U.S.C. §103 as being unpatentable over Kent in view of Ingraham. Like the Kent patent, the Ingraham patent, which is assigned to the assignee of the present invention, fails to teach

Applicant : Byron Hourmand  
Appl. No. : 08/601,268  
Page : 19

or suggest a touch control circuit that discriminates between a full intentional contact with a touch terminal and an inadvertent partial contact of the same touch terminal. Therefore, the combination of the Kent and Ingraham patents fails to teach or suggest each and every element recited in independent claim 1. For this reason claims 8-11, which depend from independent claim 1, are allowable over the combination of the Kent and Ingraham patents.

With respect to independent claim 18, the Kent and Ingraham patents both fail to teach or suggest a capacitive responsive electronic switching circuit comprising a detector circuit that compares the sensed body capacitance proximate an input touch terminal to a threshold level in order to prevent inadvertent generation of a control output signal. For these reasons, Applicant submits that independent claims 1 and 18, as well as claims 8-11 and 19 which depend therefrom, are allowable over the Kent and Ingraham patents whether considered separately or in combination.

Applicant respectfully traverses the rejection of claims 8-11, 18, and 19 under 35 U.S.C. §103 as being unpatentable over Kent in view of Kirton. The Kirton patent, like the Kent and Ingraham patents, does not disclose a touch control circuit that is capable of discriminating between a full intentional touch of a touch terminal and an inadvertent touch of a portion of the surface of the touch terminal. For these reasons, independent claims 1 and 18, as well as claims 8-11 and 19 which depend therefrom, are allowable over the teachings of the Kent and Kirton patents whether considered separately or in combination.

It is noted that the Examiner has not rejected claims 17 and 20 in the Office Action. Claim 17 depends from independent claim 12 and is believed to be allowable for the reasons

Applicant : Byron Hourmand  
Appln. No. : 08/601,268  
Page : 20

discussed above with respect to claim 12. Independent claim 20 recites a dome-shaped touch terminal. By this amendment, Applicant has amended independent claim 20 to recite that the detector circuit includes means for discriminating between a touch of the dome-shaped touch terminal by the palm of a human hand and a touch by a human finger. For the reasons stated above with respect to independent claims 1, 12, and 18, Applicant submits that independent claim 20 is allowable over the combined teachings of the Kent, Ingraham, and Kirton patents.

In this amendment, Applicant has presented new independent claim 21, and claims 22-26 which depend therefrom. New independent claim 21 defines a capacitive responsive electronic switching circuit comprising at least a detector circuit "including discriminating means for discriminating between the touch of said touch terminal covering substantially all of said area of said touch terminal and a touch covering less than substantially all of said area of said touch terminal. For the reasons discussed above with respect to the other independent claims, Applicants submit that neither the Kent, Ingraham, nor Kirton patents teach or suggest the touch control circuit including a detector circuit having such discriminating means. Therefore, new independent claim 21 as well as claims 22-26 are allowable over the references cited of record.

New independent claim 27 recites a switching circuit for a control device that comprises at least first and second touch terminals and a detector circuit that generates a control output signal for actuation of the control device when an operator is proximal or touches the second touch terminal after the operator is proximal or touches the first touch

Applicant : Byron Hourmand  
Appl. No. : 08/601,268  
Page : 21

terminal. Dependent claim 28 recites that the detector circuit generates the control signal only when the second touch terminal is actuated within a predetermined time period after the actuation of the first touch terminal. Applicant submits that none of the cited references teaches or suggests such features. New claims 29-32 depend from new independent claim 27 and are believed to be allowable for the same reasons stated above with respect to independent claim 27.

In view of the foregoing amendments and remarks, Applicant submits that the present invention as defined in the pending claims, is allowable over the prior art of record. The Examiner's reconsideration and timely allowance of the claims are requested. A Notice of Allowance is therefore respectfully solicited.

Respectfully submitted,

BYRON HOURMAND

By: Price, Heneveld, Cooper,  
DeWitt & Litton

8-22-97  
Date

  
Terry S. Callaghan  
Registration No. 34 559  
695 Kenmoor, S.E.  
Post Office Box 2567  
Grand Rapids, Michigan 49501  
(616) 949-9610

TSC/ras

Att #10

OK to enter  
DK 10/24/87

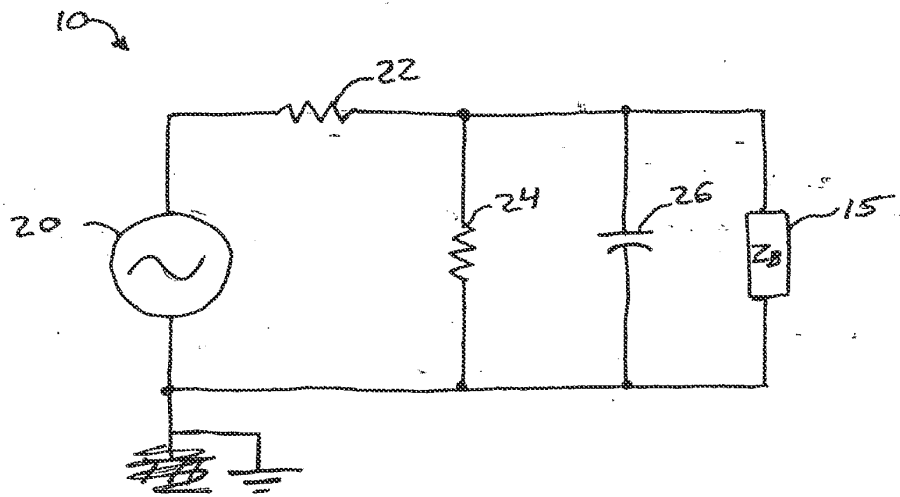

FIG. 1

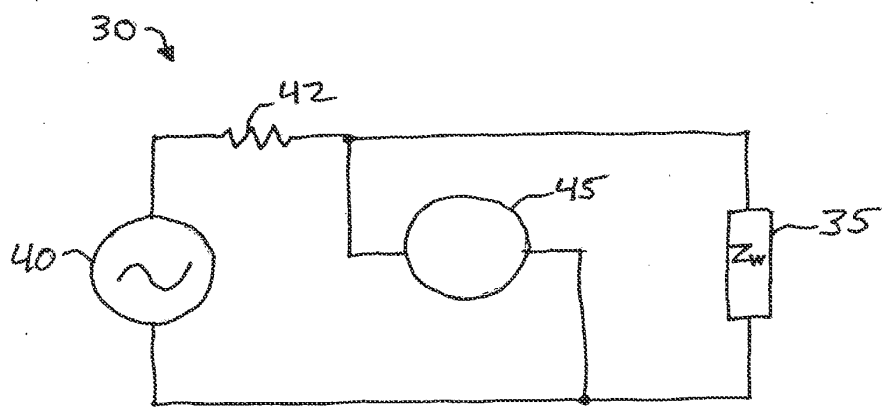

FIG. 2

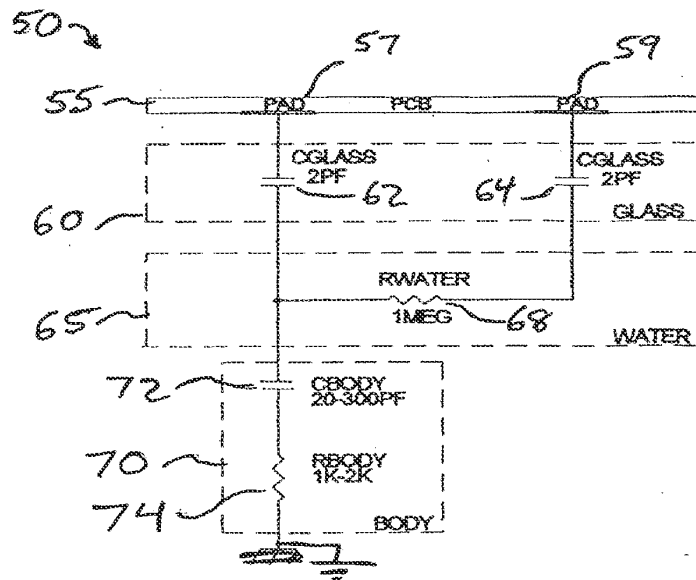

FIG. 3

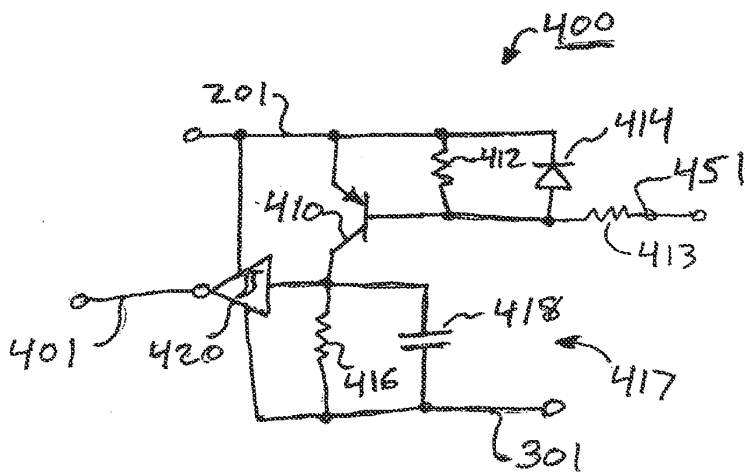

FIG. 8



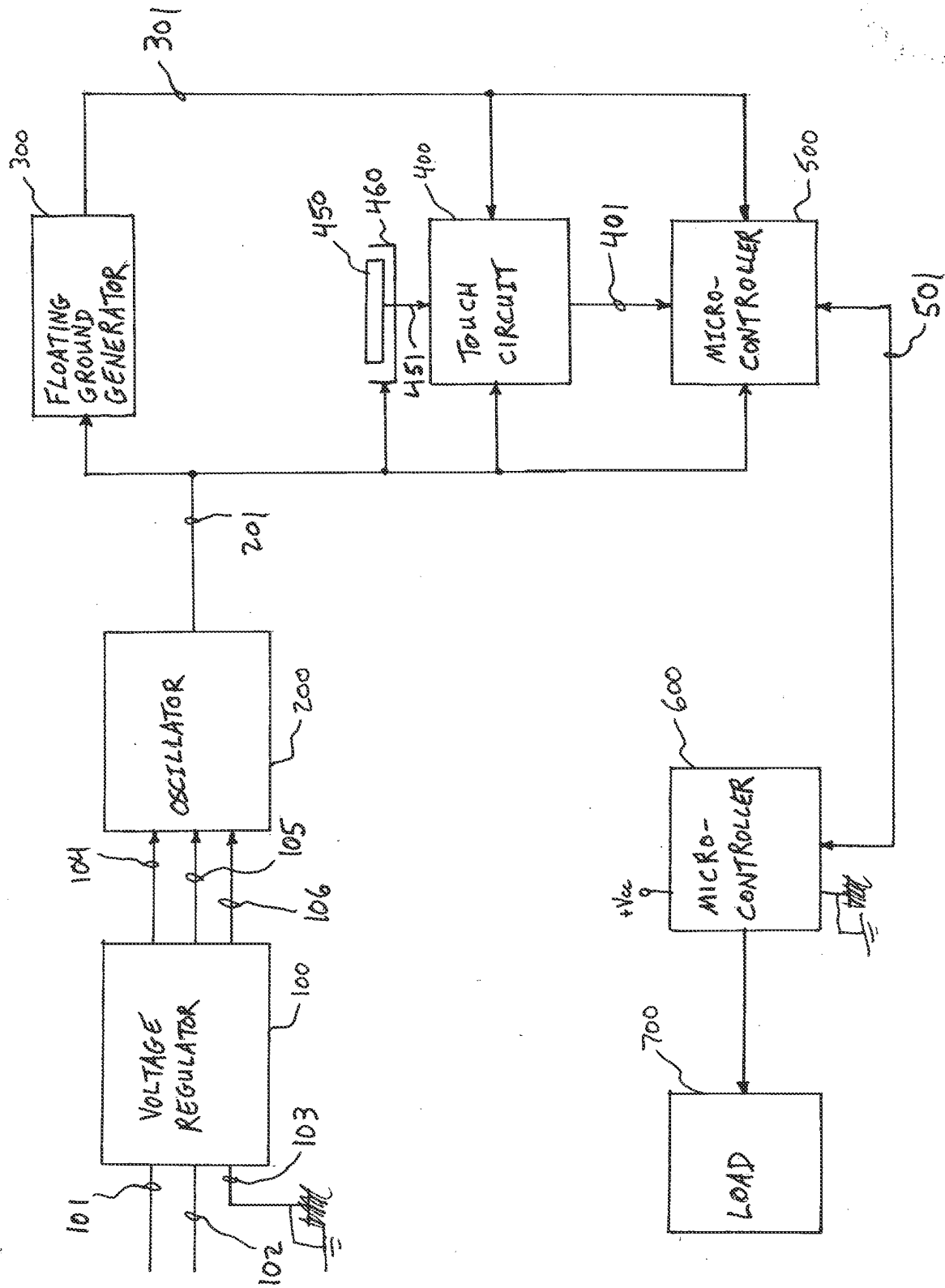

FIG. 4

FIG. 5

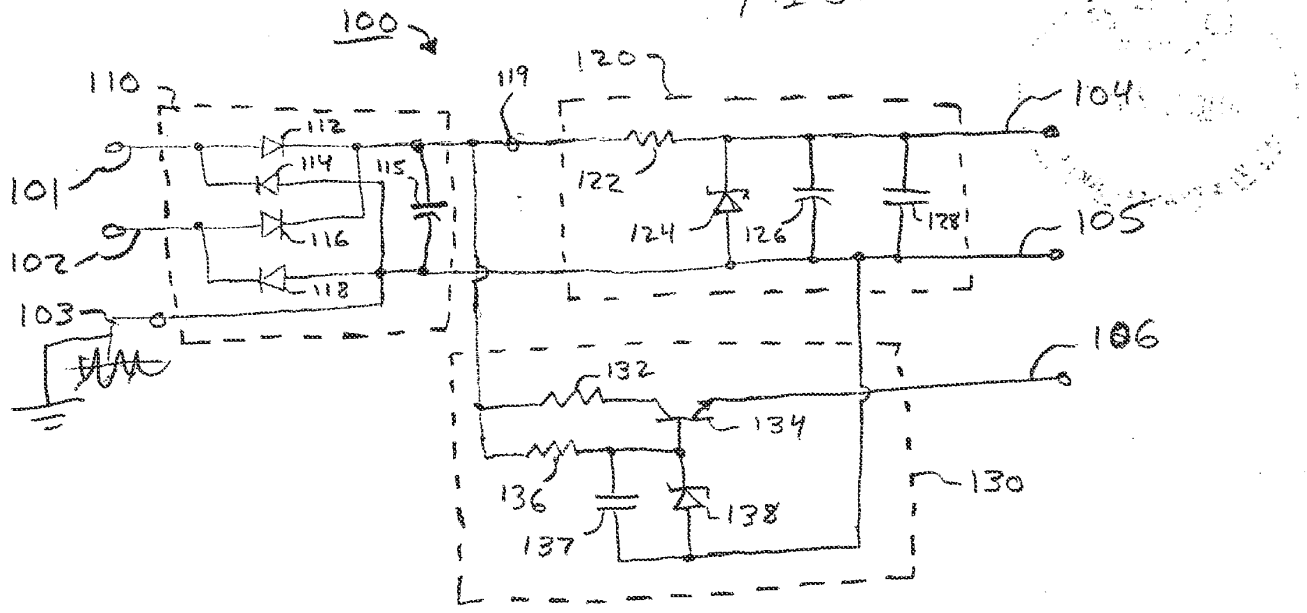

FIG. 6

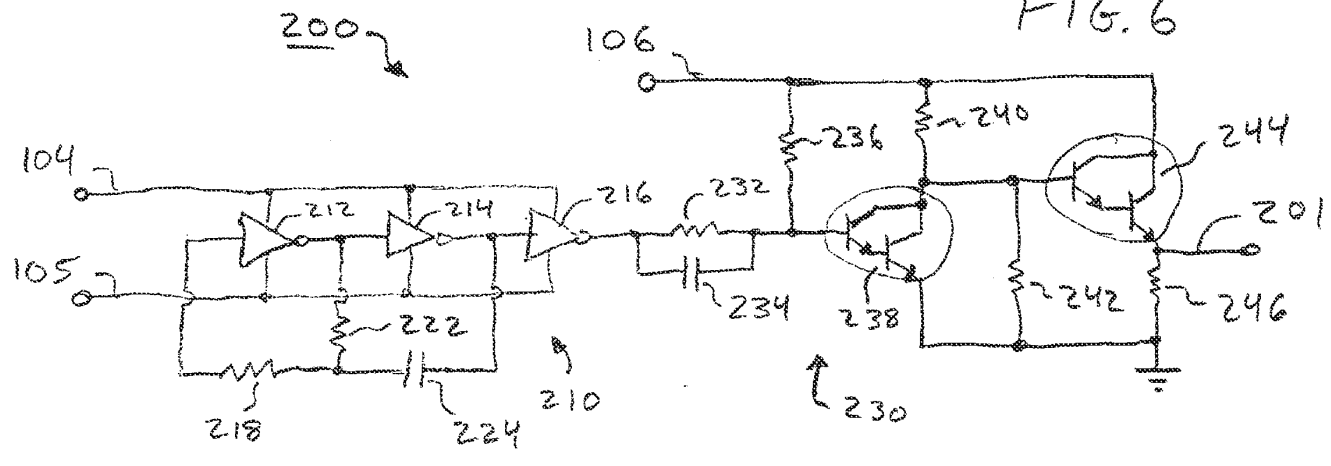
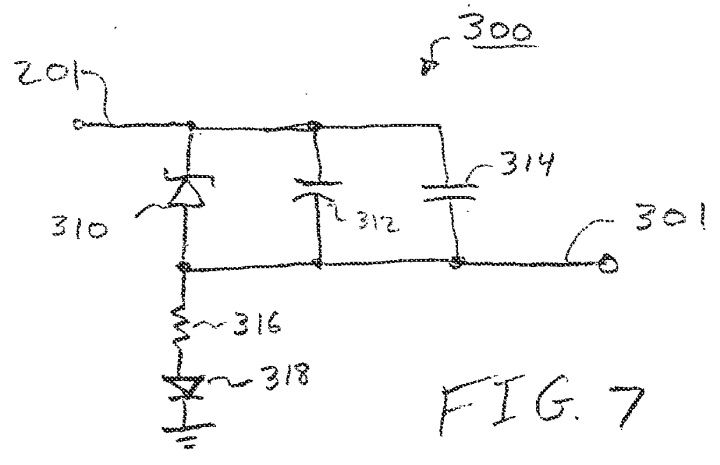

FIG. 7



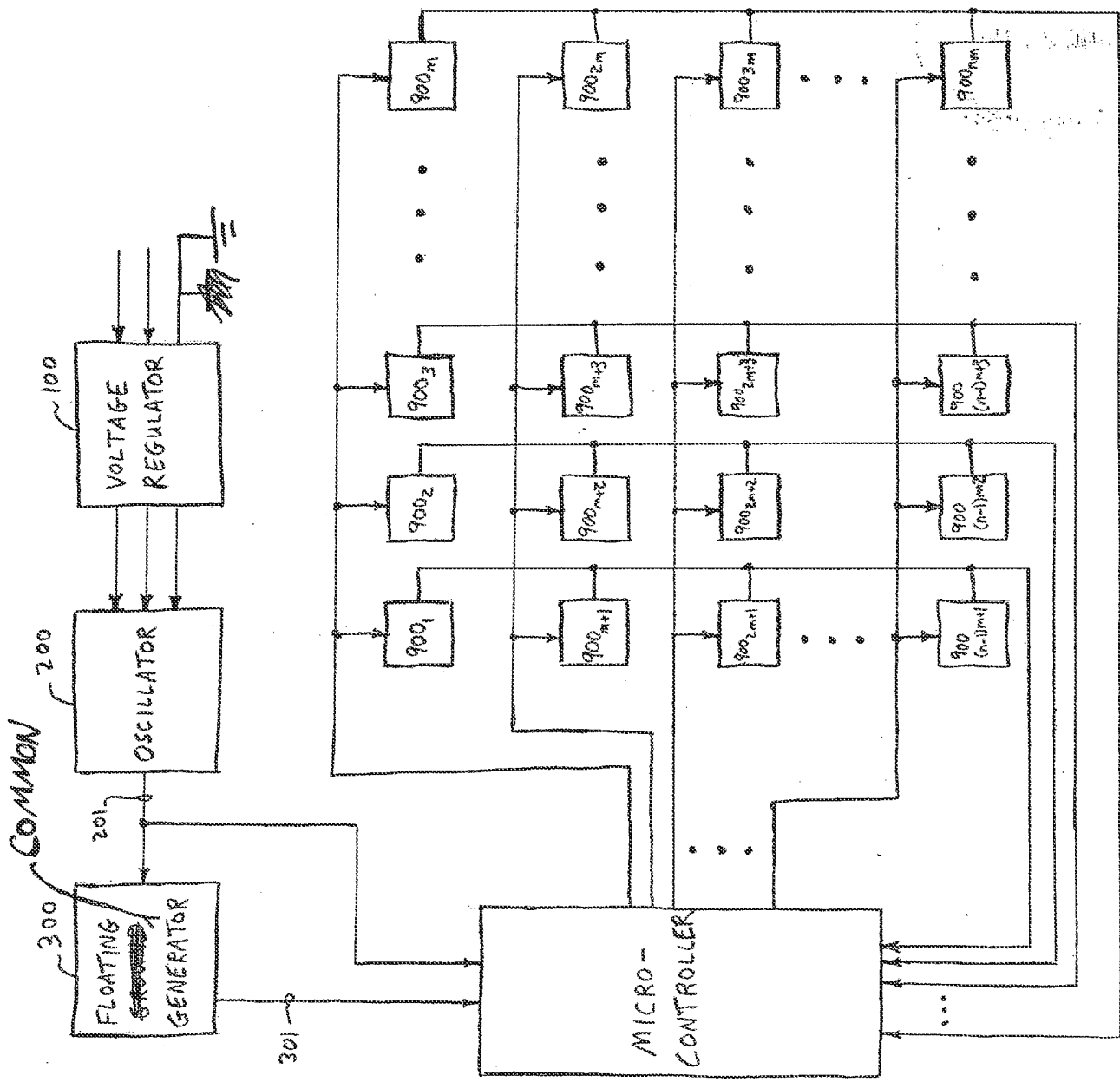

FIG. 11

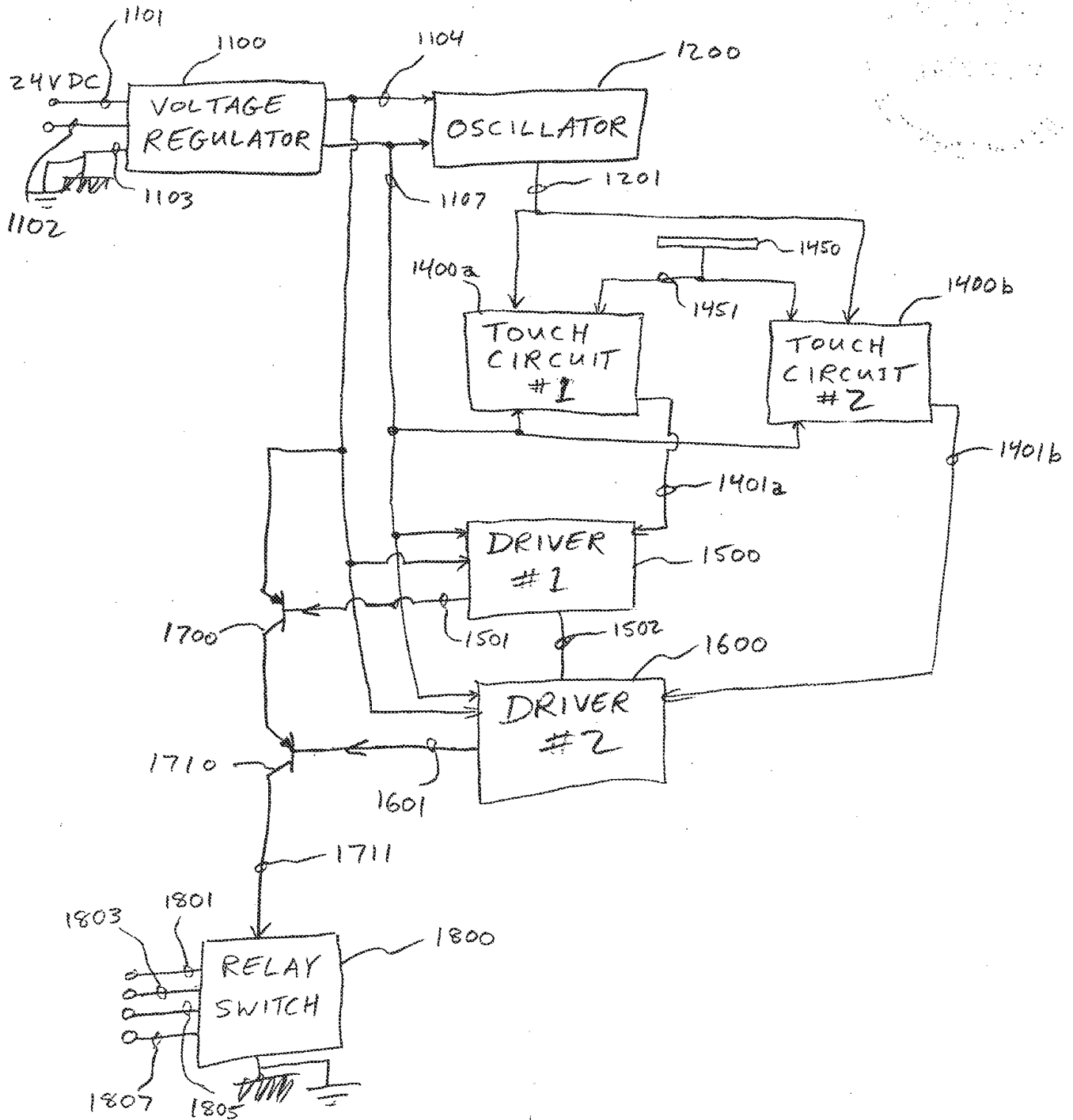

FIG. 12





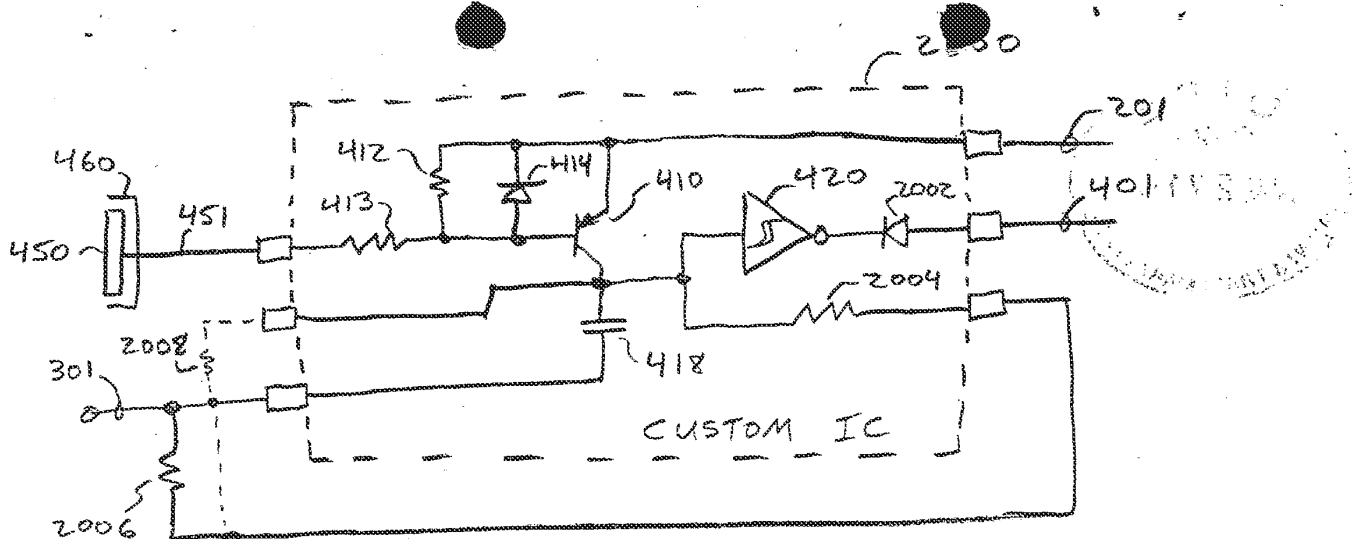

FIG. 17

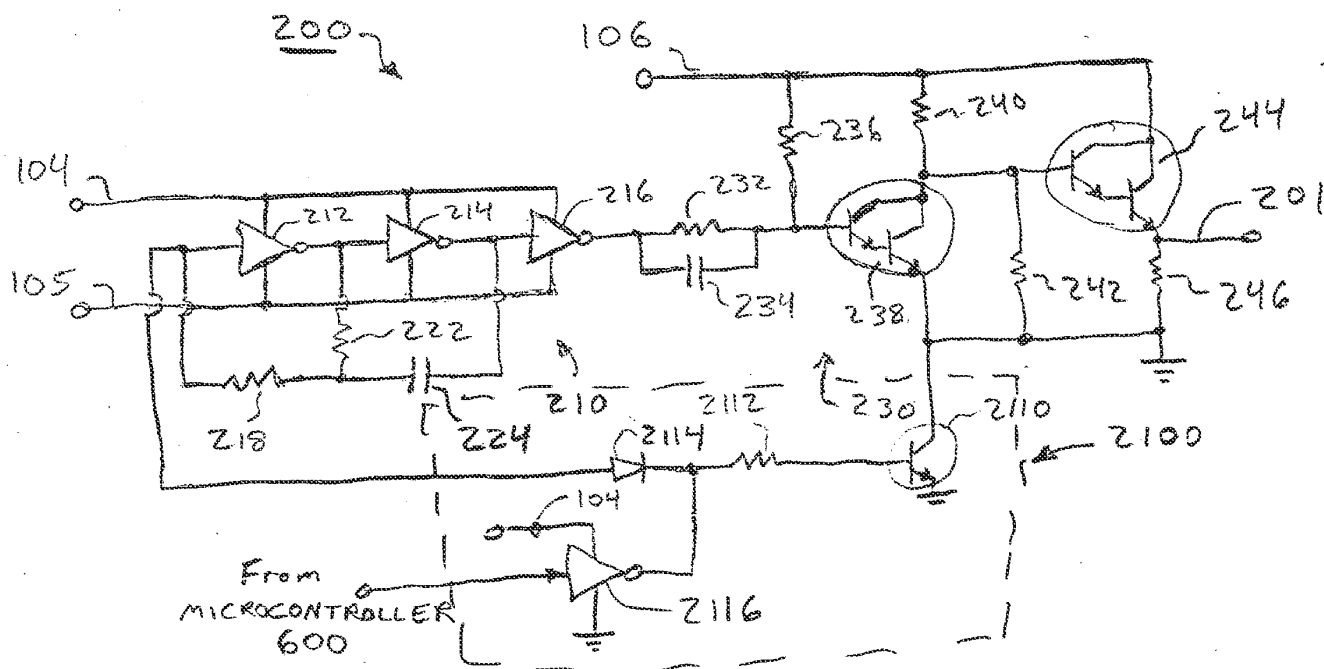

FIG. 18

GP 2107/B



Atty. Docket No. NAR01 P-310

CERTIFICATE OF MAILING

I hereby certify that this paper, together with all enclosures identified herein, are being deposited with the United States Postal Service as first class mail, addressed to the Assistant Commissioner for Patents, Washington D.C. 20231, on the date indicated below.

Date 8/22/97

Signature: Rebecca A. Schwartz

IN THE UNITED STATES PATENT AND TRADEMARK OFFICE

RECEIVED

SEP 22 1997

GROUP 2100

Handwritten notes: w/draw. corr. Sheeran 9-23-97

Art Unit : 2107
Examiner : J. Kaplan
Appl. No. : 08/601,268
Filing Date : January 31, 1996
Applicant : Byron Hourmand
For : CAPACITIVE RESPONSIVE ELECTRONIC SWITCHING CIRCUIT

Assistant Commissioner for Patents
Washington, D.C. 20231

Dear Sir:

Enclosed is a response to the Office Action dated April 22, 1997. Also enclosed are nine sheets of corrected drawings. The items checked below are appropriate:

x Applicants hereby petition for a one-month extension of time to respond to the above Office Action. The fee of \$55.00 for the Extension is enclosed.

Any fee for additional claims has been calculated as shown below:

CLAIMS AS AMENDED

Table with columns: Col. 1, Col. 2, Col. 3, Small Entity, Other Than A Small Entity. Rows include Claims Remaining After Amendment, Total Claims, Independent Claims, and TOTAL ADDITIONAL FEE FOR THIS AMENDMENT.

A

09/16/1997 SEARCHED 00000062 08601268
01 FC:202
02 FC:203
03 FC:215



Applicant : Byron Hourmand  
Appln. No. : 08/601,268  
Page : 2

- \* If the entry in Col. 1 is less than the entry in Col. 2, write "0" in Col. 3  
\*\* If the "Highest No. Previously Paid For" IN THIS SPACE is less than 20, write "20" in this space.  
\*\*\* If the "Highest No. Previously Paid For" IN THIS SPACE is less than 3, write "3" in this space.  
The "Highest No. Previously Paid For" (Total or Independent) is the highest number found from the equivalent box in Col. 1 of a prior amendment or the number of claims originally filed.

Small entity status of this application under 37 C.F.R. §§ 1.9 and 1.27 has been established by a verified statement previously submitted.

No additional fee is required.

A fee of \$292.00 to cover the cost of the additional claims added by this response is enclosed.

Please charge any additional fees or credit overpayment to Deposit Account 16 2463. A duplicate copy of this sheet is attached.

PRICE, HENEVELD, COOPER,  
DEWITT & LITTON

8-22-97

Date

  
Terry S. Callaghan  
Registration No. 34 559  
695 Kenmoor, S.E.  
Post Office Box 2567  
Grand Rapids, Michigan 49501  
(616) 949-9610

TSC/ras



UNITED STATES DEPARTMENT OF COMMERCE  
Patent and Trademark Office

Address: Box ISSUE FEE  
ASSISTANT COMMISSIONER FOR PATENTS  
Washington, D.C. 20231

NOTICE OF ALLOWANCE AND ISSUE FEE DUE

21M1/1027

PRICE HENEVELD COOPER  
DEWITT & LITTON  
695 KENMOOR DRIVE SE  
P O BOX 2567  
GRAND RAPIDS MI 49501

12

APPLICATION NO.	FILING DATE	TOTAL CLAIMS	EXAMINER AND GROUP ART UNIT	DATE MAILED
08/601,268	01/31/96	032	KAPLAN, J	2107 10/27/97
First Named Applicant	HOURMAND, BYRON			

TITLE OF INVENTION CAPACITIVE RESPONSIVE ELECTRONIC SWITCHING CIRCUIT

ATTY'S DOCKET NO.	CLASS-SUBCLASS	BATCH NO.	APPLN. TYPE	SMALL ENTITY	FEE DUE	DATE DUE
2	NAR01-P-310	307-116.000	T51 UTILITY	YES	\$660.00	01/27/98

**THE APPLICATION IDENTIFIED ABOVE HAS BEEN EXAMINED AND IS ALLOWED FOR ISSUANCE AS A PATENT. PROSECUTION ON THE MERITS IS CLOSED.**

**THE ISSUE FEE MUST BE PAID WITHIN THREE MONTHS FROM THE MAILING DATE OF THIS NOTICE OR THIS APPLICATION SHALL BE REGARDED AS ABANDONED. THIS STATUTORY PERIOD CANNOT BE EXTENDED.**

**HOW TO RESPOND TO THIS NOTICE:**

- I. Review the SMALL ENTITY status shown above.  
If the SMALL ENTITY is shown as YES, verify your current SMALL ENTITY status:
  - A. If the status is changed, pay twice the amount of the FEE DUE shown above and notify the Patent and Trademark Office of the change in status, or
  - B. If the status is the same, pay the FEE DUE shown above.

If the SMALL ENTITY is shown as NO:

- A. Pay FEE DUE shown above, or
- B. File verified statement of Small Entity Status before, or with, payment of 1/2 the FEE DUE shown above.

II. Part B of this notice should be completed and returned to the Patent and Trademark Office (PTO) with your ISSUE FEE. Even if the ISSUE FEE has already been paid by charge to deposit account, Part B should be completed and returned. If you are charging the ISSUE FEE to your deposit account, section "6b" of Part B should be completed.

III. All communications regarding this application must give application number and batch number. Please direct all communication prior to issuance to Box ISSUE FEE unless advised to the contrary.

**IMPORTANT REMINDER: Patents issuing on applications filed on or after Dec. 12, 1980 may require payment of maintenance fees. It is patentee's responsibility to ensure timely payment of maintenance fees when due.**

3. PATENT AND TRADEMARK OFFICE COPY

**Notice of Allowability**

Application No. <b>08/601,268</b>	Applicant(s) <b>Hourmand</b>
Examiner <b>Jonathan Kaplan</b>	Group Art Unit <b>2107</b>



All claims being allowable, PROSECUTION ON THE MERITS IS (OR REMAINS) CLOSED in this application. If not included herewith (or previously mailed), a Notice of Allowance and Issue Fee Due or other appropriate communication will be mailed in due course.

- This communication is responsive to the amendment filed 8/27/97.
- The allowed claim(s) is/are 1-32.
- The drawings filed on \_\_\_\_\_ are acceptable.
- Acknowledgement is made of a claim for foreign priority under 35 U.S.C. § 119(a)-(d).
  - All  Some\*  None of the CERTIFIED copies of the priority documents have been received.
  - received in Application No. (Series Code/Serial Number) \_\_\_\_\_.
  - received in this national stage application from the International Bureau (PCT Rule 17.2(a)).
- \*Certified copies not received: \_\_\_\_\_
- Acknowledgement is made of a claim for domestic priority under 35 U.S.C. § 119(e).

A SHORTENED STATUTORY PERIOD FOR RESPONSE to comply with the requirements noted below is set to EXPIRE THREE MONTHS FROM THE "DATE MAILED" of this Office action. Failure to timely comply will result in ABANDONMENT of this application. Extensions of time may be obtained under the provisions of 37 CFR 1.136(a).

- Note the attached EXAMINER'S AMENDMENT or NOTICE OF INFORMAL APPLICATION, PTO-152, which discloses that the oath or declaration is deficient. A SUBSTITUTE OATH OR DECLARATION IS REQUIRED.
- Applicant MUST submit NEW FORMAL DRAWINGS
  - because the originally filed drawings were declared by applicant to be informal.
  - including changes required by the Notice of Draftsperson's Patent Drawing Review, PTO-948, attached hereto or to Paper No. 8.
  - including changes required by the proposed drawing correction filed on 8/27/97, which has been approved by the examiner.
  - including changes required by the attached Examiner's Amendment/Comment.

Identifying indicia such as the application number (see 37 CFR 1.84(c)) should be written on the reverse side of the drawings. The drawings should be filed as a separate paper with a transmittal letter addressed to the Official Draftsperson.

- Note the attached Examiner's comment regarding REQUIREMENT FOR THE DEPOSIT OF BIOLOGICAL MATERIAL.

Any response to this letter should include, in the upper right hand corner, the APPLICATION NUMBER (SERIES CODE/SERIAL NUMBER). If applicant has received a Notice of Allowance and Issue Fee Due, the ISSUE BATCH NUMBER and DATE of the NOTICE OF ALLOWANCE should also be included.

**Attachment(s)**

- Notice of References Cited, PTO-892
- Information Disclosure Statement(s), PTO-1449, Paper No(s) 9
- Notice of Draftsperson's Patent Drawing Review, PTO-948
- Notice of Informal Patent Application, PTO-152
- Interview Summary, PTO-413
- Examiner's Amendment/Comment
- Examiner's Comment Regarding Requirement for Deposit of Biological Material
- Examiner's Statement of Reasons for Allowance

  
WILLIAM M. SHOOP, JR.  
SUPERVISORY PATENT EXAMINER  
ART UNIT 217



07/31/97

FORM PTO-1449 U.S. DEPARTMENT OF COMMERCE (Rev. 2-32) PATENT AND TRADEMARK OFFICE  INFORMATION DISCLOSURE STATEMENT BY APPLICANT  (Use several sheets if necessary)	ATTY. DOCKET NO. NAR01 P-310	SERIAL NO. 08/601,268
	APPLICANT(S) BYRON HOURMAND	
	FILING DATE 01/31/96	ART UNIT 2107

U.S. PATENT DOCUMENTS

EXAMINER INITIAL	DOCUMENT NUMBER	DATE	NAME	CLASS	SUB-CLASS	FILING DATE IF APPRO- PRIATE	
						Y	N
<i>W</i>	5 5 7 2 2 0 5	11/05/96	Caldwell et al.	341	33		

FOREIGN PATENT DOCUMENTS

EXAMINER INITIAL	DOCUMENT NUMBER	DATE	COUNTRY	CLASS	SUB-CLASS	TRANSLA- TION	
						Y	N

OTHER DOCUMENTS (Including Author, Title, Date, Pertinent Pages, Etc.)

EXAMINER INITIAL	

EXAMINER <i>Jonathan Kaplan</i>	DATE CONSIDERED <i>10/24/97</i>
EXAMINER: Initial if citation considered, whether or not citation is in conformance with MPEP 609; Draw line through citation if not in conformance and not considered. Include copy of this form with next communication to applicant.	

4100  
 5796183  
 4/17/98  
 094  
 307/116.000  
 2811  
 4/17/98  
 6/2/98

Atty. Docket No. NAR01 P-310

CERTIFICATE OF MAILING

I hereby certify that this paper, together with all enclosures identified herein, are being deposited with the United States Postal Service as first class mail, addressed to the Assistant Commissioner for Patents, Box Issue Fee, Washington D.C. 20231, on the date indicated below.

Date 11/3/97  
 Rebecca A. Schwartz  
 Rebecca A. Schwartz

IN THE UNITED STATES PATENT AND TRADEMARK OFFICE

Art Unit : 2107  
 Examiner : J. Kaplan  
 Appln. No. : 08/601,268  
 Filing Date : January 31, 1996  
 Applicant : Byron Hourmand  
 For : CAPACTIVE RESPONSIVE ELECTRONIC SWITCHING CIRCUIT  
 Batch No. : T51

NOV 06 1997  
 RECEIVED  
 Pub. Div.

Asst. Commissioner for Patents  
 Box Issue Fee  
 Washington, D.C. 20231

6-19-98  
 7530 Pub. Div  
 PN = 5,796,183

Dear Sir:

Entered bk for 10/14/98

AMENDMENT UNDER 37 C.F.R. §1.312

Pursuant to 37 C.F.R. §1.312 and subject to the recommendation of the Examiner and the approval of the Commissioner, and without withdrawing the case from issue, kindly amend the subject application as follows.

In the Claims:

Claim 27, line 11, after "when" delete "said".

REMARKS

The above-identified application was allowed in the Office Action mailed October 27, 1997. The issue fee has not been paid. Subsequent to the receipt of the Notice of

Applicant : Byron Hourmand  
Appl. No. : 08/601,268  
Page : 2

Allowance, Applicant noted a typographical error in claim 27. The requested amendment is submitted to correct this error. The requested amendment is fully supported by the specification and drawings, will not require an additional search, and does not raise new issues. Therefore, Applicant respectfully requests that this amendment be entered and the requested change made.

The reference for the application within the issue branch as indicated on the Notice of Allowance, is T51. If there are any fees due in connection with the filing of this amendment, please charge the fees to our deposit account No. 16 2463.

Respectfully submitted,

BYRON HOURMAND

By: Price, Heneveld, Cooper,  
DeWitt & Litton

11-3-97  
Date

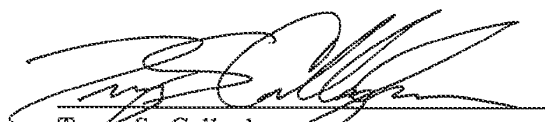
  
Terry S. Callaghan  
Registration No. 34 559  
695 Kenmoor, S.E.  
Post Office Box 2567  
Grand Rapids, Michigan 49501  
(616) 949-9610

TSC/ras

PB

2,400,000  
501 15

PART B - ISSUE FEE TRANSMITTAL

**MAILING INSTRUCTIONS:** This form should be used for transmitting the ISSUE FEE. Blocks 2 through 6 should be completed where appropriate. All further correspondence including the Issue Fee Receipt, the Patent, advance orders and notification of maintenance fees will be mailed to addressee entered in Block 1 unless you direct otherwise, by: (a) specifying a new correspondence address in Block 3 below; or (b) providing the PTO with a separate "FEE ADDRESS" for maintenance fee notifications with the payment of Issue Fee or thereafter. See reverse for Certificate of Mailing, below.

Under the Paperwork Reduction Act of 1995, no persons are required to respond to a collection of information unless it displays a valid OMB control number.

**Burden Hour Statement:** This form is estimated to take 0.2 hours to complete. Time will vary depending on the needs of the individual case. Any comments on the amount of time required to complete this form should be sent to the Chief Information Officer, Patent and Trademark Office, Washington, D.C. 20231.

DO NOT SEND FEES OR COMPLETED FORMS TO THIS ADDRESS. SEND TO: Box Issue Fee, Assistant Commissioner for Patents, Washington D.C. 20231

1. CORRESPONDENCE ADDRESS  
  
PRICE HENEVELD COOPER  
DEWITT & LITTON  
695 KENMOOR DRIVE SE  
P O BOX 2567  
GRAND RAPIDS MI 49501

21 RECEIVED  
Publishing Division  
JAN 29 1998  
C7

2. INVENTOR(S) ADDRESS CHANGE (Complete only if there is a change)  
INVENTOR'S NAME  
Street Address  
City, State and ZIP Code  
CO-INVENTOR'S NAME  
Street Address  
City, State and ZIP Code  
 Check if additional changes are enclosed

APPLICATION NO.	FILING DATE	TOTAL CLAIMS	EXAMINER AND GROUP ART UNIT	DATE MAILED
08/601,268	01/31/96	032	KAPLAN, J 2107	10/27/97
First Named Applicant	HOURMAND, BYRON			

TITLE OF INVENTION CAPACITIVE RESPONSIVE ELECTRONIC SWITCHING CIRCUIT

ATTY'S DOCKET NO.	CLASS-SUBCLASS	BATCH NO.	APPLN. TYPE	SMALL ENTITY	FEE DUE	DATE DUE
2	NAR01-P-310	307-116,000	T51 UTILITY	YES	\$660.00	01/27/98

3. Correspondence address change (Complete only if there is a change)

4. For printing on the patent front page, list the names of not more than 3 registered patent attorneys or agents OR, alternatively, the name of a firm having as a member a registered attorney or agent. If no name is listed, no name will be printed.

Price, Heneveld  
Cooper, DeWitt &  
Litton  
2  
3

02/09/1998 CASHBY 00000148 08601268  
01 FC:242 660.00 OP  
02 FC:561 15.00 OP

5. ASSIGNMENT DATA TO BE PRINTED ON THE PATENT (print or type)

(1) NAME OF ASSIGNEE: Nartron Corporation  
(2) ADDRESS: (CITY & STATE OR COUNTRY) Reed City, Michigan

A.  This application is NOT assigned.  
 Assignment previously submitted to the Patent and Trademark Office.  
 Assignment is being submitted under separate cover. Assignments should be directed to Box ASSIGNMENTS.  
**PLEASE NOTE:** Unless an assignee is identified in Block 5, no assignee data will appear on the patent. Inclusion of assignee data is only appropriate when an assignment has been previously submitted to the PTO or is being submitted under separate cover. Completion of this form is NOT a substitute for filing an assignment.

6a. The following fees are enclosed:  
 Issue Fee  Advance Order - # of Copies 5  
6b. The following fees should be charged to:  
DEPOSIT ACCOUNT NUMBER 16 2463  
(ENCLOSE A COPY OF THIS FORM)  
 Issue Fee  Advance Order - # of Copies  
 Any Deficiencies in Enclosed Fees  
The COMMISSIONER OF PATENTS AND TRADEMARKS is requested to apply the Issue Fee to the application identified above.  
Authorized Signatory  
Perry S. Callaghan 34 559 01/26/98  
NOTE: The Issue Fee will not be accepted from anyone other than the applicant, a registered attorney or agent, or the assignee or other party in interest as shown by the records of the Patent and Trademark Office.

Certificate of Mailing

Note: If this certificate of mailing is used, it can only be used to transmit the Issue Fee. This certificate cannot be used for any other accompanying papers. Each additional paper, such as an assignment or formal drawing, must have its own certificate of mailing.

I hereby certify that this correspondence is being deposited with the United States Postal Service with sufficient postage as first class mail in an envelope addressed to: Box ISSUE FEE, Assistant Commissioner for Patents, Washington, D.C. 20231

on: January 26, 1998 (Date)  
Rebecca A. Schwartz (Name of person making deposit)  
*Rebecca A. Schwartz* (Signature)  
1/26/98 (Date)

1. TRANSMIT THIS FORM WITH FEE



UNITED STATES DEPARTMENT OF COMMERCE  
Patent and Trademark Office

Address: COMMISSIONER OF PATENTS AND TRADEMARKS  
Washington, D.C. 20231

APPLICATION NO.	FILING DATE	FIRST NAMED INVENTOR	ATTORNEY DOCKET NO.
08/601,268	01/31/96	HOURMAND	B NAR01-P-310

PRICE HENEVELD COOPER  
DEWITT & LITTON  
695 KENMOOR DRIVE SE  
P O BOX 2567  
GRAND RAPIDS MI 49501

B2M1/0304

EXAMINER  
KAFLAN, J

ART UNIT	PAPER NUMBER
2107	

DATE MAILED: 03/04/98

Please find below and/or attached an Office communication concerning this application or proceeding.

Commissioner of Patents and Trademarks



*Supplemental  
Notice of Allowability*

Application No. 08/601,268	Applicant(s) Hourmand
Examiner Jonathan Kaplan	Group Art Unit 2107



All claims being allowable, PROSECUTION ON THE MERITS IS (OR REMAINS) CLOSED in this application. If not included herewith (or previously mailed), a Notice of Allowance and Issue Fee Due or other appropriate communication will be mailed in due course.

This communication is responsive to the letter mailed 2/3/98

The allowed claim(s) is/are 1-32

The drawings filed on \_\_\_\_\_ are acceptable.

Acknowledgement is made of a claim for foreign priority under 35 U.S.C. § 119(a)-(d).

All  Some\*  None of the CERTIFIED copies of the priority documents have been  
 received.

received in Application No. (Series Code/Serial Number) \_\_\_\_\_

received in this national stage application from the International Bureau (PCT Rule 17.2(a)).

\*Certified copies not received: \_\_\_\_\_

Acknowledgement is made of a claim for domestic priority under 35 U.S.C. § 119(e).

A SHORTENED STATUTORY PERIOD FOR RESPONSE to comply with the requirements noted below is set to EXPIRE THREE MONTHS FROM THE "DATE MAILED" of this Office action. Failure to timely comply will result in ABANDONMENT of this application. Extensions of time may be obtained under the provisions of 37 CFR 1.136(a).

Note the attached EXAMINER'S AMENDMENT or NOTICE OF INFORMAL APPLICATION, PTO-152, which discloses that the oath or declaration is deficient. A SUBSTITUTE OATH OR DECLARATION IS REQUIRED.

Applicant MUST submit NEW FORMAL DRAWINGS

because the originally filed drawings were declared by applicant to be informal.

including changes required by the Notice of Draftsperson's Patent Drawing Review, PTO-948, attached hereto or to Paper No. \_\_\_\_\_

including changes required by the proposed drawing correction filed on \_\_\_\_\_, which has been approved by the examiner.

including changes required by the attached Examiner's Amendment/Comment.

Identifying indicia such as the application number (see 37 CFR 1.84(c)) should be written on the reverse side of the drawings. The drawings should be filed as a separate paper with a transmittal letter addressed to the Official Draftsperson.

Note the attached Examiner's comment regarding REQUIREMENT FOR THE DEPOSIT OF BIOLOGICAL MATERIAL.

Any response to this letter should include, in the upper right hand corner, the APPLICATION NUMBER (SERIES CODE/SERIAL NUMBER). If applicant has received a Notice of Allowance and Issue Fee Due, the ISSUE BATCH NUMBER and DATE of the NOTICE OF ALLOWANCE should also be included.

Attachment(s)

Notice of References Cited, PTO-892

Information Disclosure Statement(s), PTO-1449, Paper No(s). 5

Notice of Draftsperson's Patent Drawing Review, PTO-948

Notice of Informal Patent Application, PTO-152

Interview Summary, PTO-413

Examiner's Amendment/Comment

Examiner's Comment Regarding Requirement for Deposit of Biological Material

Examiner's Statement of Reasons for Allowance

  
WILLIAM M. SHOOP, JR.  
SUPERVISORY PATENT EXAMINER  
ART UNIT 217



Express Mail No. Rb7825787641  
Sheet 1 of 2

Form PTO-1449

U.S. DEPARTMENT OF COMMERCE  
PATENT AND TRADEMARK OFFICE

ATTY. DOCKET NO.

SERIAL NO.

NAR01 P-310

INFORMATION DISCLOSURE STATEMENT  
BY APPLICANT

APPLICANTS

Byron Hourmand

FILING DATE

GROUP

U.S. PATENT DOCUMENTS

EXAMINER INITIAL	PATENT NUMBER								ISSUE DATE	NAME	CLASS	SUBCLASS	FILING DATE IF APPROPRIATE
	5	4	5	3	6	4	4						
4x	5	4	5	3	6	4	4	09/26/95	Yap et al.				
	5	3	8	6	2	1	9	01/31/95	Greanias et al.				
	5	2	3	5	2	1	7	08/10/93	Kirton				
	5	2	3	3	2	3	1	08/03/93	Wieth et al.				
	5	2	0	8	5	1	6	05/04/93	Saidian				
	5	0	8	7	8	2	5	02/11/92	Ingraham				
	5	0	6	6	8	9	8	11/19/91	Miller et al.				
	5	0	1	2	1	2	4	04/30/91	Hollaway				
	4	9	3	9	3	8	2	07/03/90	Gruodis				
	4	9	1	0	5	0	4	03/20/90	Eriksson				
	4	8	3	1	2	7	9	05/16/89	Ingraham				
	4	7	5	8	7	3	5	07/19/88	Ingraham				
	4	7	3	1	5	4	8	03/15/88	Ingraham				
	4	4	7	6	4	6	3	10/09/84	Ng et al.				
	4	3	7	4	3	8	1	02/15/83	Ng et al.				
	4	3	6	0	7	3	7	11/23/82	Leopold				
	4	3	2	3	8	2	9	04/06/82	Witney et al.				
	4	3	0	8	4	4	3	12/29/81	Tucker et al.				
	4	2	8	9	9	8	0	09/15/81	McLaughlin				
	4	2	8	9	9	7	2	09/15/81	Wern				
4x	4	2	6	4	8	3	1	04/28/81	Wern				
4x	4	2	5	7	1	1	7	03/17/81	Besson				

FOREIGN PATENT DOCUMENTS

DOCUMENT NUMBER	PUBLICATION DATE	COUNTRY	CLASS	SUBCLASS	TRANSLATION	
					YES	NO

OTHER DOCUMENTS (Including Author, Title, Date, Pertinent Pages, Etc.)

EXAMINER

Jonathan Kaplan

DATE CONSIDERED

4/11/97

EXAMINER: Initial if citation is considered, whether or not citation is in conformance with MPEP 609; Draw line through citation if not in conformance and not considered. Include copy of this form with next communication to applicant.

Express Mail No. RB782578764U

Sheet 2 of 2

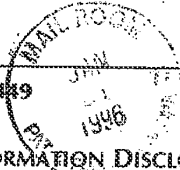

Form PTO-1489

U.S. DEPARTMENT OF COMMERCE  
PATENT AND TRADEMARK OFFICE

ATTY. DOCKET NO. **NAR01 P-310**

SERIAL NO.

INFORMATION DISCLOSURE STATEMENT  
BY APPLICANT

APPLICANTS  
**Byron Hourmand**

FILING DATE

GROUP

U.S. PATENT DOCUMENTS

EXAMINER INITIAL	PATENT NUMBER							ISSUE DATE	NAME	CLASS	SUBCLASS	FILING DATE IF APPROPRIATE
	4	2	4	6	5	3	3					
JK	4	2	4	6	5	3	3	01/20/81	Chiang			
	4	2	3	7	4	2	1	12/02/80	Waldron			
	4	2	2	0	8	1	5	09/02/80	Gibson et al.			
	4	2	1	3	0	6	1	07/15/80	Conner			
	4	2	1	1	9	5	9	07/08/80	Deavenport et al.			
	4	2	1	0	8	2	2	07/01/80	Wern			
	4	1	5	9	4	7	3	06/26/79	Senk			
	4	1	5	2	6	2	9	05/01/79	Raupp			
	4	1	1	9	8	6	4	10/10/78	Petrizio			
	4	1	0	1	8	0	5	07/18/78	Stone			
	4	0	7	1	6	8	9	01/31/78	Talmage et al.			
	4	0	3	1	4	0	8	06/21/77	Holz			
	4	0	1	6	4	5	3	04/05/77	Moennig			
	3	9	8	4	7	5	7	10/05/76	Gott et al.			
	3	9	6	5	4	6	5	06/22/76	Alexander			
	3	9	1	9	5	9	6	11/11/75	Bellis			
	3	9	1	1	2	1	5	10/07/75	Hurst et al.			
	3	8	9	9	7	1	3	08/12/75	Barkan et al.			
	3	7	9	8	3	7	0	03/19/74	Hurst			
	3	6	6	6	9	8	8	05/30/72	Bellis			
3	6	5	1	3	9	1	03/21/72	Vogelsberg				
3	6	4	1	4	1	0	02/08/72	Vogelsberg				
3	5	4	9	9	0	9	08/25/69	Adelson et al.				

FOREIGN PATENT DOCUMENTS

DOCUMENT NUMBER	PUBLICATION DATE	COUNTRY	CLASS	SUBCLASS	TRANSLATION	
					YES	NO

OTHER DOCUMENTS (Including Author, Title, Date, Pertinent Pages, Etc.)

EXAMINER: **Jonathan Kaplan**

DATE CONSIDERED: **4/11/97**

EXAMINER: Initial if citation is considered, whether or not citation is in conformance with MPEP 609; Draw line through citation if not in conformance and not considered. Include copy of this form with next communication to applicant.



ede \$  
#17  
MJ

Atty. Docket No. NAR01 P-310

CERTIFICATE OF MAILING

I hereby certify that this paper, together with all enclosures identified herein, are being deposited with the United States Postal Service as first class mail, addressed to the Assistant Commissioner for Patents, Washington D.C. 20231, on the date indicated below.

1/20/99  
Date

*Rebecca A. Schwartz*  
Rebecca A. Schwartz

IN THE UNITED STATES PATENT AND TRADEMARK OFFICE

Patentee : Byron Hourmand  
Patent No. : 5,796,183  
Issue Date : August 18, 1998

**CERTIFICATE**

FEB - 4 1999

Assistant Commissioner for Patents  
Washington, D.C. 20231

**CORRECTION**

Dear Sir:

A request is being made for a Certificate of Correction in the above-identified patent, which issued with the following errors identified by page and line from the application file.

- \* Page 11, line 9, "such a" should be --such as--.
- Page 19, line 4, before "water" insert --condensed--.
- \* Page 31, line 5, "is" should be --as--.
- \* Page 30, line 3, "it's" should be --its--.
- \* Page 40, line 3, "references" should be --reference--.
- \* Page 43, line 8, "it's" should be --its--.
- \* Page 43, line 9, "it's" should be --its--.
- \* Page 43, line 10, "it's" should be --its-- (all occurrences).
- \* Page 43, line 12, "it's" should be --its--.
- \* Page 43, line 17, "it's" should be --its--.
- \* Page 44, line 8, "it's" should be --its--.
- \* Page 44, line 9, "it's" should be --its--.
- \* Page 44, line 13, "it's" should be --its-- (both occurrences).
- \* Page 45, line 10, "it's" should be --its--.

*Mary H. ...*  
APR 15 1999  
FOR THE COMMISSIONER OF PAT. & T.M.

01/29/1999 NABGAT1 00000207 5796183

01 FC:145

100.00 OP

Patentee : Byron Hourmand  
Patent No. : 5,796,183  
Page : 2

- \* Page 45, line 11, "it's" should be --its--.
- \* Page 45, line 14, "it's" should be --its--.
- \* Page 46, line 11, "it's" should be --its--.
- \* Page 46, line 14, "it's" should be --its-- (both occurrences).
- \* Page 46, line 19, "it's" should be --its--.
- \* Page 47, line 11, "it's" should be --its--.
- \* Page 47, line 15, "schmitt" should be --Schmitt--.

Page 55, claim 7 [11], line 3, after "microcontroller." delete "by an operator's body . . .  
higher frequencies."

- \* Amendment A, page 11, claim 18, line 12, after "electrical" insert --path--.
  - \* Amendment A, page 11, claim 18, line 12, delete "path".
- 312 Amendment, page 1, claim 27, line 11, after "when" delete "said".

Enclosed is the Certificate of Correction Form PTO 1050 identifying errors by column and line from the patent which are chargeable to the Official Printer. Also enclosed is a check for \$100.00 to cover our errors, which are identified with an asterisk. The Commissioner is hereby authorized to charge any additional payment, or to credit any overpayment, to Deposit Account No. 16-2463.

Respectfully submitted,

BYRON HOURMAND

By: Price, Heneveld, Cooper,  
DeWitt & Litton

1-20-99  
Date

TSC/ras

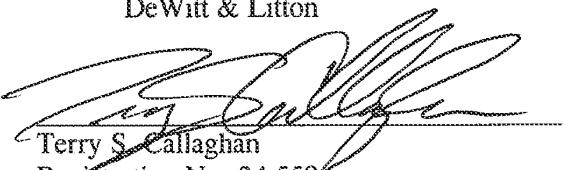
  
Terry S. Callaghan  
Registration No. 34 559  
695 Kenmoor, S.E./Post Office Box 2567  
Grand Rapids, Michigan 49501  
(616) 949-9610

Staple  
Here  
Only!

# UNITED STATES PATENT AND TRADEMARK OFFICE CERTIFICATE OF CORRECTION

PATENT NO. : 5,796,183  
DATED : August 18, 1998  
INVENTOR(S) : Byron Hourmand

It is certified that error appears in the above-identified patent and that said Letters Patent is hereby corrected as shown below:

- Column 5, line 52, "such a" should be --such as--. *a*
- Column 9, line 31, before "water" insert --condensed--. *C*
- Column 14, line 35, "is" should be --as--. *a*
- Column 13, line 65, "it's" should be --its--. *a*
- Column 18, line 38, "references" should be --reference--. *a*
- Column 20, line 7, "it's" should be --its-- (both occurrences). *a*
- Column 20, line 9, "it's" should be --its--. *a*
- Column 20, line 10, "it's" should be --its-- (both occurrences). *a*
- Column 20, line 13, "it's" should be --its--. *a*
- Column 20, line 20, "it's" should be --its--. *a*
- Column 20, line 39, "it's" should be --its--. *a*
- Column 20, line 40, "it's" should be --its--. *a*
- Column 20, line 46, "it's" should be --its--. *a*
- Column 20, line 47, "it's" should be --its--. *a*
- Column 21, line 8, "it's" should be --its--. *a*
- Column 21, line 9, "it's" should be --its--. *a*
- Column 21, line 15, "it's" should be --its--. *a*

MAILING ADDRESS OF SENDER:

Terry S. Callaghan  
Price, Heneveld, Cooper,  
DeWitt & Litton  
Post Office Box 2567  
Grand Rapids, MI 49501

PATENT NO. 5,796,183

No. of add'l copies  
@ \$0.50 per page

FORM PTO 1050

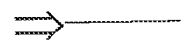

Staple  
Here  
Only!

# UNITED STATES PATENT AND TRADEMARK OFFICE CERTIFICATE OF CORRECTION

PATENT NO. : 5,796,183  
DATED : August 18, 1998  
INVENTOR(S) : Byron Hourmand

It is certified that error appears in the above-identified patent and that said Letters Patent is hereby corrected as shown below:

- Column 21, line 42, "it's" should be --its--.
- Column 21, line 46, "it's" should be --its--.
- Column 21, line 47, "it's" should be --its--.
- Column 21, line 56, "it's" should be --its--.
- Column 22, line 8, "it's" should be --its--.
- Column 22, line 13, "schmitt" should be --Schmitt--.
- Column 26, lines 22-27, after "microcontroller." delete "by an operator's body . . . higher frequencies."
- Column 27, line 44, after "electrical" insert --path--.
- Column 27, line 45, delete "path".
- Column 29, line 1, after "when" delete "said".

*a*  
*a*  
*a*  
*a*  
*a*  
*a*  
*a*  
*a*  
*a*  
*a*

*C*

MAILING ADDRESS OF SENDER:

Terry S. Callaghan  
Price, Heneveld, Cooper,  
DeWitt & Litton  
Post Office Box 2567  
Grand Rapids, MI 49501

PATENT NO. 5,796,183

No. of add'l copies  
@ \$0.50 per page

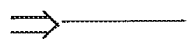



UNITED STATES PATENT AND TRADEMARK OFFICE

Commissioner for Patents  
United States Patent and Trademark Office  
P.O. Box 1450  
Alexandria, VA 22313-1450  
www.uspto.gov

**BROOKS KUSHMAN P.C.**  
**1000 TOWN CENTER**  
**TWENTY-SECOND FLOOR**  
**SOUTHFIELD, MI 48075**

**MAILED**  
**AUG 25 2011**  
**OFFICE OF PETITIONS**

In re Patent No. 5,796,183 :  
Issue Date: August 18, 1998 :  
Application No. 08/601,268 : **ON PETITION**  
Filed: January 31, 1996 :  
Attorney Docket No. :

This is a decision on the petition filed August 19, 2011 under 37 CFR 1.323, which is being treated as a request under 37 CFR 1.324 to correct the name of the inventors by way of a Certificate of Correction.

The petition is **GRANTED**.

Petitioner request that the inventorship of this application be amended by the addition of **JOHN M. WASHELESKI** of Cadillac, Michigan, and **STEPHEN R. W. COOPER**, of Fowlerville, Michigan, based on the Consent Judgment dated September 8 2010 under 35 USC 256. Petitioner includes with the renewed petition an Oath having the above inventors.

The inventorship of this patent has been amended by the addition of **JOHN M. WASHELESKI** and **STEPHEN R. W. COOPER**.

Telephone inquiries concerning this decision may be directed to the undersigned at (571) 272-0602. Inquiries regarding the issuance of a certificate of correction should be directed to the Certificate of Correction Branch at (571) 272-4200.

Thurman K. Page  
Petitions Examiner  
Office of Petitions

Enclosure: Corrected filing receipt





UNITED STATES PATENT AND TRADEMARK OFFICE

UNITED STATES DEPARTMENT OF COMMERCE  
United States Patent and Trademark Office  
Address: COMMISSIONER FOR PATENTS  
P.O. Box 1450  
Alexandria, Virginia 22313-1450  
www.uspto.gov

APPLICATION NUMBER	FILING or 371(c) DATE	GRP ART UNIT	FIL FEE REC'D	ATTY. DOCKET NO	TOT CLAIMS	IND CLAIMS
08/601,268	01/31/1996	2836	771	NAR0227L	20	4

CONFIRMATION NO. 3176

CORRECTED FILING RECEIPT



22045  
BROOKS KUSHMAN P.C.  
1000 TOWN CENTER  
TWENTY-SECOND FLOOR  
SOUTHFIELD, MI 48075

Date Mailed: 08/25/2011

Receipt is acknowledged of this non-provisional patent application. The application will be taken up for examination in due course. Applicant will be notified as to the results of the examination. Any correspondence concerning the application must include the following identification information: the U.S. APPLICATION NUMBER, FILING DATE, NAME OF APPLICANT, and TITLE OF INVENTION. Fees transmitted by check or draft are subject to collection. Please verify the accuracy of the data presented on this receipt. **If an error is noted on this Filing Receipt, please submit a written request for a Filing Receipt Correction. Please provide a copy of this Filing Receipt with the changes noted thereon. If you received a "Notice to File Missing Parts" for this application, please submit any corrections to this Filing Receipt with your reply to the Notice. When the USPTO processes the reply to the Notice, the USPTO will generate another Filing Receipt incorporating the requested corrections**

Applicant(s)

BYRON HOURMAND, HERSEY, MI;  
JOHN M. WASHELESKI, Cadillac, MI;  
STEPHEN R. W. COOPER, Fowlerville, MI;

Power of Attorney: The patent practitioners associated with Customer Number 22045

Domestic Priority data as claimed by applicant

Foreign Applications (You may be eligible to benefit from the Patent Prosecution Highway program at the USPTO. Please see <http://www.uspto.gov> for more information.)

If Required, Foreign Filing License Granted: 07/24/1996

The country code and number of your priority application, to be used for filing abroad under the Paris Convention, is **US 08/601,268**

Projected Publication Date: None, application is not eligible for pre-grant publication

Non-Publication Request: No

Early Publication Request: No

**\*\* SMALL ENTITY \*\***

**Title**

CAPACITIVE RESPONSIVE ELECTRONIC SWITCHING CIRCUIT

**Preliminary Class**

307

**PROTECTING YOUR INVENTION OUTSIDE THE UNITED STATES**

Since the rights granted by a U.S. patent extend only throughout the territory of the United States and have no effect in a foreign country, an inventor who wishes patent protection in another country must apply for a patent in a specific country or in regional patent offices. Applicants may wish to consider the filing of an international application under the Patent Cooperation Treaty (PCT). An international (PCT) application generally has the same effect as a regular national patent application in each PCT-member country. The PCT process simplifies the filing of patent applications on the same invention in member countries, but does not result in a grant of "an international patent" and does not eliminate the need of applicants to file additional documents and fees in countries where patent protection is desired.

Almost every country has its own patent law, and a person desiring a patent in a particular country must make an application for patent in that country in accordance with its particular laws. Since the laws of many countries differ in various respects from the patent law of the United States, applicants are advised to seek guidance from specific foreign countries to ensure that patent rights are not lost prematurely.

Applicants also are advised that in the case of inventions made in the United States, the Director of the USPTO must issue a license before applicants can apply for a patent in a foreign country. The filing of a U.S. patent application serves as a request for a foreign filing license. The application's filing receipt contains further information and guidance as to the status of applicant's license for foreign filing.

Applicants may wish to consult the USPTO booklet, "General Information Concerning Patents" (specifically, the section entitled "Treaties and Foreign Patents") for more information on timeframes and deadlines for filing foreign patent applications. The guide is available either by contacting the USPTO Contact Center at 800-786-9199, or it can be viewed on the USPTO website at <http://www.uspto.gov/web/offices/pac/doc/general/index.html>.

For information on preventing theft of your intellectual property (patents, trademarks and copyrights), you may wish to consult the U.S. Government website, <http://www.stopfakes.gov>. Part of a Department of Commerce initiative, this website includes self-help "toolkits" giving innovators guidance on how to protect intellectual property in specific countries such as China, Korea and Mexico. For questions regarding patent enforcement issues, applicants may call the U.S. Government hotline at 1-866-999-HALT (1-866-999-4158).

**LICENSE FOR FOREIGN FILING UNDER**

**Title 35, United States Code, Section 184**

**Title 37, Code of Federal Regulations, 5.11 & 5.15**

**GRANTED**

The applicant has been granted a license under 35 U.S.C. 184, if the phrase "IF REQUIRED, FOREIGN FILING LICENSE GRANTED" followed by a date appears on this form. Such licenses are issued in all applications where the conditions for issuance of a license have been met, regardless of whether or not a license may be required as

set forth in 37 CFR 5.15. The scope and limitations of this license are set forth in 37 CFR 5.15(a) unless an earlier license has been issued under 37 CFR 5.15(b). The license is subject to revocation upon written notification. The date indicated is the effective date of the license, unless an earlier license of similar scope has been granted under 37 CFR 5.13 or 5.14.

This license is to be retained by the licensee and may be used at any time on or after the effective date thereof unless it is revoked. This license is automatically transferred to any related applications(s) filed under 37 CFR 1.53(d). This license is not retroactive.

The grant of a license does not in any way lessen the responsibility of a licensee for the security of the subject matter as imposed by any Government contract or the provisions of existing laws relating to espionage and the national security or the export of technical data. Licensees should apprise themselves of current regulations especially with respect to certain countries, of other agencies, particularly the Office of Defense Trade Controls, Department of State (with respect to Arms, Munitions and Implements of War (22 CFR 121-128)); the Bureau of Industry and Security, Department of Commerce (15 CFR parts 730-774); the Office of Foreign Assets Control, Department of Treasury (31 CFR Parts 500+) and the Department of Energy.

**NOT GRANTED**

No license under 35 U.S.C. 184 has been granted at this time, if the phrase "IF REQUIRED, FOREIGN FILING LICENSE GRANTED" DOES NOT appear on this form. Applicant may still petition for a license under 37 CFR 5.12, if a license is desired before the expiration of 6 months from the filing date of the application. If 6 months has lapsed from the filing date of this application and the licensee has not received any indication of a secrecy order under 35 U.S.C. 181, the licensee may foreign file the application pursuant to 37 CFR 5.15(b).

UNITED STATES PATENT AND TRADEMARK OFFICE  
**CERTIFICATE OF CORRECTION**

PATENT NO. : 5,796,183  
APPLICATION NO. : 08/601268  
DATED : August 18, 1998  
INVENTOR(S) : Byron Hourmand et al.

Page 1 of 1

It is certified that error appears in the above-identified patent and that said Letters Patent is hereby corrected as shown below:

Title Page, Item (75) Inventor, should read --(75) Inventors: Byron Hourmand,  
Hersey, MI (US); John M. Washeleski, Cadillac, MI (US); Stephen R. W. Cooper,  
Fowlerville, MI (US)--.

Signed and Sealed this  
Eleventh Day of October, 2011

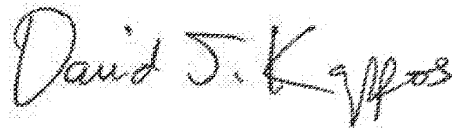

David J. Kappos  
*Director of the United States Patent and Trademark Office*

IN THE UNITED STATES PATENT AND TRADEMARK OFFICE

U.S. Patent No.:	5,796,183 B1	§	Docket No.:	5796183RX
Issued:	August 18, 1998	§	Inventors:	Hourmand et al.
Filed:	January 31, 1996	§	Patent Owner:	UUSI, LLC
Control No.	TBD	§	Examiner:	TBD

For: Capacitive Responsive Electronic Switching Circuit

Mail Stop *Ex Parte* Reexam  
Attn: Central Reexamination Unit  
Commissioner for Patents  
P.O. Box 1450  
Alexandria, VA 22313-1450

REQUEST FOR *EX PARTE* REEXAMINATION UNDER 35 U.S.C. §§ 302-307

Dear Sir:

Patent Owner UUSI, LLC respectfully requests *Ex Parte* Reexamination, pursuant to the provisions of 35 U.S.C. §§ 302–307 (2002), of claims 18 and 27 of United States Patent No. 5,796,183 (the “183 Patent”). This patent is still enforceable.

As set forth below, the prior art reference submitted herewith was not previously before the Office, and presents new, non-cumulative technological teachings not considered during the 183 Patent prosecution history.

**I. OVERVIEW OF THE `183 PATENT AND ITS PROSECUTION HISTORY**

Section II.A below provides an overview of the subject matter of the `183 Patent, while Section II.B provides an overview of its prosecution history.

**A. The `183 Patent**

The `183 Patent, a copy of which is provided as Exhibit A, issued on August 18, 1998 from an application filed on January 31, 1996. The `183 Patent generally relates to a capacitive responsive electronic switching circuit including an oscillator providing a periodic output signal, an input touch terminal defining an area for an operator to provide an input by proximity and touch, and a detector circuit coupled to the oscillator for receiving the periodic output signal from the oscillator, and coupled to the input touch terminal. *See, e.g.*, `183 Patent, Abstract.

The `183 Patent contains 32 total claims, with claims 1, 9, 12, 16, 18, 20, 24 and 27 being independent. Claims 18 and 27, which are the subject of this reexam request, require an oscillator, a plurality of touch terminals, and a detector circuit.

An embodiment with a single touch terminal is shown in Figure 4, and an embodiment with multiple touch terminals is shown in Figure 11, both of which are reproduced below:

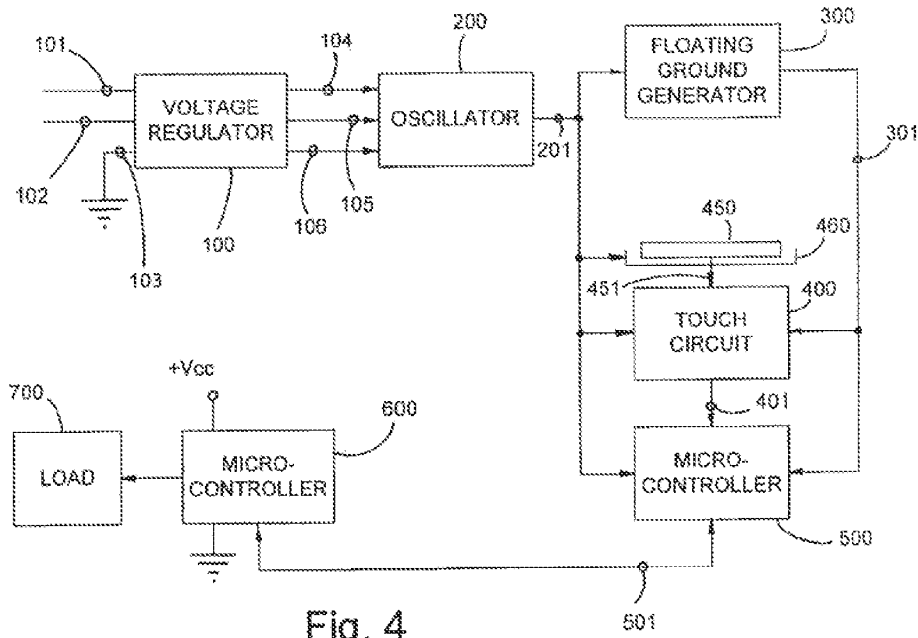

Fig. 4

Fig. 4 of the '183 Patent

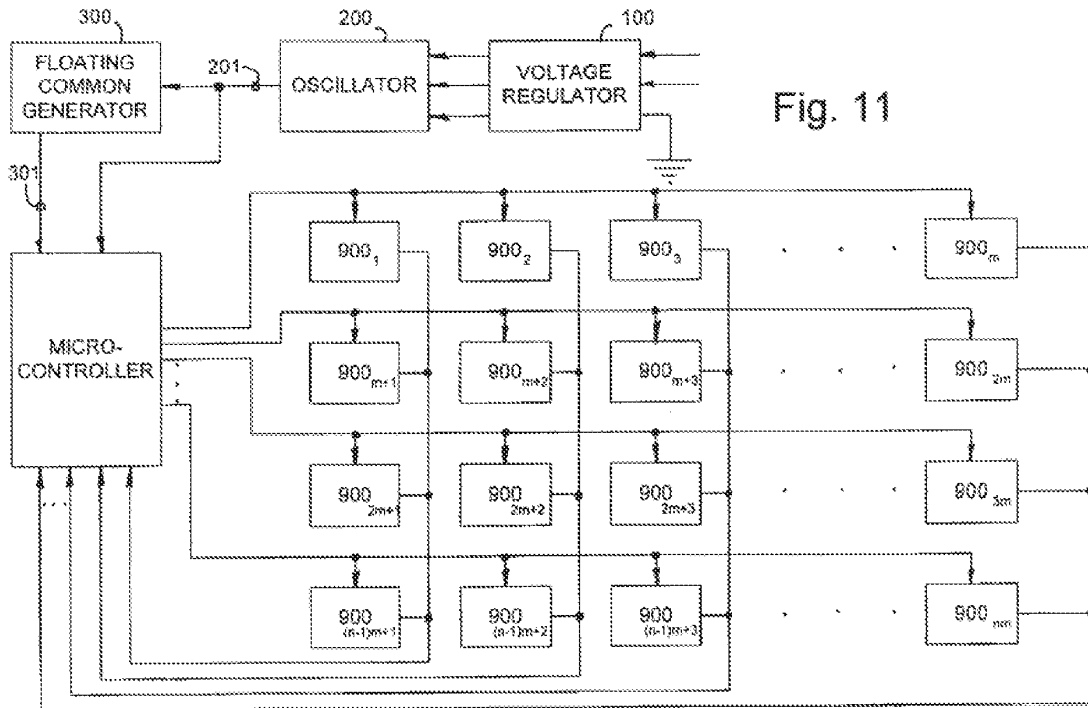

Fig. 11

Fig. 11 of the '183 Patent

The multiple touch pad circuit of Figure 11 is a variation of the embodiment shown in Figure 4, but with an array of touch circuits designated as 900<sub>1</sub> through 900<sub>nm</sub>. *See, e.g., id.* at col. 18:34-41. The touch detection circuit offers improvements in detection sensitivity that allow close control of the degree of proximity (ideally very close proximity) that is required for actuation and to enable employment of a multiplicity of small sized touch terminals in a physically close array such as a keyboard. *See, e.g., id.* at col. 5:53-57.

Microcontroller 500 selects each row of the touch circuits 900<sub>1</sub> to 900<sub>nm</sub> by providing the signal from oscillator 200 to selected rows of touch circuits. *See, e.g., id.* at col. 18:43-46. The values of the resistors and capacitors utilized in oscillator 200 may be varied from those disclosed above to provide for different oscillator output frequencies. *See, e.g., id.* at col. 14:22-25. Although the preferred frequency is at or above 100 kHz, and more preferably at or above 800 kHz, it is conceivable that frequencies as low as 50 kHz could be used provided the frequency creates a difference in the impedance paths of adjacent pads that is sufficient enough to accurately distinguish between an intended touch and the touch of an adjacent pad. *See, e.g., id.* at col. 11:19-25.

Microcontroller 500 sequentially activates the touch circuit rows and associates the received inputs from the columns of the array with the activated touch circuit(s). *See, e.g., id.* at col. 46-49. The detector circuit is responsive to signals from the oscillator and the presence of an operator's body capacitance to ground coupled to the touch terminal when in proximity or touched by an operator to provide a control output signal. *See, e.g., id.* at Abstract. Another method for implementing capacitive touch switches relies on the change in capacitive coupling between a touch terminal and ground. *See, e.g., id.* at col. 3:44-46.



**B. The Prosecution History of the `183 Patent**

A copy of selected portions of the prosecution history of the `183 Patent is provided in Exhibit B.

The `183 Patent issued from U.S. Patent Application Serial No. 08/601,268 (“the `268 application”), filed on January 31, 1996, and naming Byron Hourmand as the sole inventor. The `268 application was filed with 20 total claims, of which four were independent. Claims 21-32 were added by subsequent amendment. A cross-reference between the issued claims and the application claims from which they issued is provided below for convenience.

Issued Claim	Appl. Claim	Issued Claim	Appl. Claim	Issued Claim	Appl. Claim	Issued Claim	Appl. Claim
1	1	9	5	17	16	25	25
2	2	10	6	18	18	26	26
3	3	11	7	19	19	27	27
4	4	12	12	20	20	28	28
5	8	13	13	21	21	29	29
6	9	14	14	22	22	30	30
7	10	15	17	23	23	31	31
8	11	16	15	24	24	32	32

In an Office Action dated April 22, 1997, the Examiner rejected application claims 6, 7 and 16 under 35 U.S.C. § 112, second paragraph, as being indefinite. *See* Ex. B, `183 Patent File History, Office Action, p. 2 (Apr. 22, 1997). Claims 6, 7 and 16 would be allowable if rewritten to overcome the section 112 rejection, and to include all of the limitations of the base claim and any intervening claims. *See id.* at p. 5.

Claims 1-4 and 12-14 were rejected under 35 U.S.C. § 102(b) as being anticipated by U.S. Patent No. 4,352,141 to Kent (“Kent”). *See id.* Claims 8-11, 18, and 19 were rejected under 35 § U.S.C. 103(a) as being unpatentable over Kent in view of U.S. Patent No. 5,087,825 to Ingraham (“Ingraham”), *see id.* at p. 3, and claims 8-11, 18 and 19 were rejected under 35 U.S.C.

§ 103(a) as being unpatentable over Kent in view of U.S. Patent No. 5,235,217 to Kirton (“Kirton”). *See id.* at p. 4. Lastly, claims 5 and 15 were objected to as being dependent upon a rejected base claim, but would be allowable if rewritten in independent form including all the limitations of the base claim and any intervening claims. *See id.* at p. 5.

In response, the Applicant filed an amendment on August 22, 1997, amending claims 1, 3, 5, 6, 12-18 and 20, and adding new claims 21-32. In particular, the Applicant amended independent claim 18 as follows:

18. (Amended) A capacitive responsive electronic switching circuit comprising:  
an oscillator providing a periodic output signal having a predefined frequency;  
a plurality of input touch terminals defining adjacent areas on a dielectric substrate for an operator to provide inputs by proximity and touch; and  
a detector circuit coupled to said oscillator for receiving said periodic output signal from said oscillator, and coupled to said input touch terminals, said detector circuit being responsive to signals from said oscillator and the presence of an operator's body capacitance to ground coupled said touch terminals when proximal or touched by an operator to provide a control output signal,  
wherein said predefined frequency of said oscillator is selected to decrease the impedance of said dielectric substrate relative to the impedance of any contaminate that may create an electrical on said dielectric substrate path between said adjacent areas, and wherein said detector circuit compares the sensed body capacitance to ground proximate an input touch terminal to a threshold level to prevent inadvertent generation of the control output signal.

Ex. B, '183 Patent File History, Amendment, p. 11 (Aug. 22, 1997). The Applicant argued that the Kent and Ingraham patents both fail to teach or suggest a capacitive responsive electronic switching circuit comprising a detector circuit that compares the sensed body capacitance proximate an input touch terminal to a threshold level in order to prevent inadvertent generation of a control output signal. *See id.* at p. 19. The Applicant further argued that the Kirton patent, like the Kent and Ingraham patents, does not disclose a touch control circuit that is capable of discriminating between a full intentional touch of a touch terminal and an inadvertent touch of a portion of the surface of the touch terminal. *See id.*

With respect to new independent claim 27, the Applicant argued none of the cited references teaches or suggests a switching circuit for a control device that comprises at least first and second touch terminals and a detector circuit that generates a control output signal for actuation of the control device when an operator is proximal or touches the second touch terminal after the operator is proximal or touches the first touch terminal. *See id.* at pp. 20-21.

The Examiner issued a Notice of Allowance on October 27, 1997, allowing all of the pending claims. *See Ex. B, '183 Patent File History, Notice of Allowance, p. 2 (Oct. 27, 1997).* The Applicant then filed a section 312 amendment on November 3, 1997 to delete the word "said" after the word "when" in claim 27, line 11. *See Ex. B, '183 Patent File History, Amendment Under 37 C.F.R. § 1.312, p. 1 (Nov. 3, 1997).* The issue fee was paid on January 26, 1998, *see Ex. B, '183 Patent File History, Issue Fee Transmittal, p. 1 (Jan. 26, 1998),* and the '183 Patent subsequently issued on August 18, 1998.

The Applicant filed a certificate of correction on January 20, 1999, which was accepted by the patent office on May 11, 1999. In claim 18, the word "path" was inserted after the word "electrical" in column 27, line 44 of the '183 Patent, and the word "path" was deleted from column 27, line 45 of the '183 Patent. *See Ex. B, '183 Patent File History, Cert. of Correction, p. 3 (May 11, 1999).* In claim 27, the word "said" was deleted after the word "when." *See id.*

The Patent Owner subsequently made several attempts to correct the inventorship of the patent, which resulted in the inventorship being changed to be Byron Hourmand, John M. Washeleski and Stephen R. W. Cooper. *See Ex. B, '183 Patent File History, Petition Decision (Aug. 25, 2011); see also Corrected Filing Receipt, p. 1 (Aug. 25, 2011); Certificate of Correction (Oct. 11, 2011).*

## **II. SUBSTANTIAL NEW QUESTION (“SNQ”) OF PATENTABILITY**

Section III.A below provides a list of the prior art reference relied upon in the present request. Section III.B provides an overview of the prior art reference. Section III.C provides a statement regarding an SNQ of patentability for claims 18 and 27 of the `183 Patent with respect to the new reference.

|

### **A. Listing of Prior Art Patents and Publications**

Reexamination of claims 18 and 27 of the `183 Patent is requested in view of the following reference:

Exhibit C      Boie et al., U.S. Patent No. 5,463,388, filed on January 29, 1993 and issued on October 31, 1996 (“Boie `388”), which qualifies as 35 U.S.C. § 102(a)-type prior art.

### **B. Overview of Prior Art Patents and Publications**

As discussed in more detail below, Boie`388 presents new, non-cumulative technological teachings not considered during the `183 Patent prosecution history.

#### **1. Boie `388**

Boie `388 generally relates to sensors for capacitively sensing the position or movement of an object, such as a finger, on a surface. *See, e.g.*, Boie `388, col. 1:6-8. A computer input device comprises a thin, insulating surface covering an array of electrodes arranged in a grid pattern and connected in columns and rows. *See, e.g., id.* at Abstract. Each column and row is connected to circuitry for measuring the capacitance seen by each column and row. *See, e.g., id.* The position of an object with respect to the array is determined from the centroid of such capacitance values, which is calculated in a microcontroller. *See, e.g., id.* Figure 4, reproduced below, illustrates a block diagram of a two-dimensional capacitive position sensor.

FIG. 4

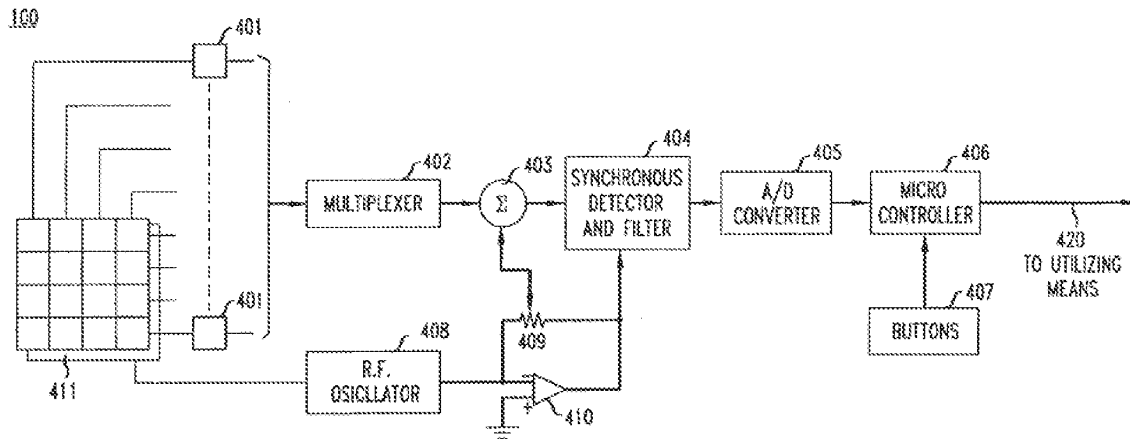

Fig. 4 of Boie '38

Each row and column of electrodes from array 100 is connected to an integrating amplifier and bootstrap circuit 401, each of which can be selected by multiplexer 402 under control of microcontroller 406. *See, e.g., Boie '388, col. 3:56-61.* The selected output is forwarded to summing circuit 403, the output of which is converted by synchronous detector and filter 404 to a signal related to the capacitance of the row or column selected by multiplexer 402. *See, e.g., id. at col. 3:62-67.* RF oscillator 408 provides an RF signal of, for example, 100 kilohertz, to circuits 401, synchronous detector and filter 404 via inverter 410, and guard plane 411, which is a substantially continuous plane parallel to array 100 and associated connections, and serves to isolate array 100 from extraneous signals. *See, e.g., id. at col. 3:67-col. 4:5.*

To measure separate capacitance values for each electrode in array 100 instead of the collective capacitances of subdivided electrode elements connected in rows and columns, a circuit 401 is provided for each electrode in array 100 and multiplexer 402 is enlarged to accommodate the outputs from all circuits 401. *See, e.g., id. at col. 4:14-21.* The output of synchronous detector and filter 404 is converted to digital form by analog-to-digital converter

405 and forwarded to microcontroller 406 so that microcontroller 406 obtains a digital value representing the capacitance seen by any row or column of electrode elements (or electrode if measured separately) selected by multiplexer 402. *See, e.g., id.* at col. 4:22-28.

### C. Statement Pointing Out Each SNQ of Patentability

Boie `388 was not cited during the original patent prosecution of the `183 Patent, and presents new, non-cumulative technological teachings with respect to `183 Patent claims 18 and 27.

#### 1. Claim 18

During the original prosecution, the Applicant amended independent claim 18 to recite “wherein said detector circuit compares the sensed body capacitance to ground proximate an input touch terminal to a threshold level to prevent inadvertent generation of the control output signal,” and argued that the cited art did not teach or suggest these limitations. After the Applicant made this amendment, the Examiner allowed claim 18.

Boie `388 discloses,

Referring to FIG. 6, microcomputer 406 reads the initial capacitance values for all the elements in array 100 and stores such values (step 601). Such initial values should reflect the state of array 100 without a finger or other object being nearby, accordingly, it may be desirable to repeat step 601 a number of times and then to select the minimum capacitance values read as the initial values, thereby compensating for the effect of any objects moving close to array 100 during the initialization step. After initialization, all capacitance values are periodically read and the initial values subtracted to yield a remainder value for each element (step 602). If one or more of the remainders exceeds a preset threshold (step 603), indicating that an object is close to or touching array 100, then the x and y coordinates of the centroid of capacitance for such object can be calculated from such remainders (step 604). . . . To avoid spurious operation, it may be desirable to require that two or more measurements exceed the preset threshold. The threshold can be set to some percentage of the range of A/D converter 405, for example 10-15% of such range.

Boie `388, col. 5:10-48; *see also id.* at Fig. 6. Boie `388 thus presents new, non-cumulative technological teachings related to the elements of claim 18 added by amendment, and such teachings were not considered in the cited art during the `183 Patent prosecution history. If the original Examiner had known of Boie `388, the Examiner likely would have considered it relevant, and likely would have cited it during the original prosecution. Boie `388 therefore raises an SNQ of patentability with respect to independent claim 18.

## 2. Claim 27

During the prosecution of the `183 Patent, the Applicant added independent claim 27, and argued that the cited art did not teach or suggest a detector circuit that generates a control output signal for actuation of the control device when an operator is proximal or touches the second touch terminal after the operator is proximal or touches the first touch terminal. After the Applicant added claim 27 and made this argument, the Examiner allowed claim 27.

Boie `388 discloses,

In using the position sensor of the invention as a computer mouse or trackball to control a cursor, movement of the mouse or trackball is emulated by touching array 100 with finger 102, or some other object, and stroking finger 102 over array 100 to move the cursor. Changes in position of the finger with respect to array 100 are reflected in corresponding changes in position of the cursor. Thus, for such an application, microcontroller 406 sends data over lead 420 relating to changes in position. FIG. 6 is a flow chart of the operation of microcontroller 406 in such an application.

Boie `388, col. 4:67-col. 5:9; *see also id.* at Fig. 6. Boie `388 thus presents new, non-cumulative technological teachings related to the elements of claim 27 argued by the Applicant, and such teachings were not considered in the cited art during the `183 Patent prosecution history. If the original Examiner had known of Boie `388, the Examiner likely would have considered it relevant, and likely would have cited it during the original prosecution. Boie `388 therefore raises an SNQ of patentability with respect to independent claim 27.

**III. DETAILED EXPLANATION OF THE RELEVANCY AND MANNER OF APPLYING THE PRIOR ART REFERENCES TO EVERY CLAIM FOR WHICH REEXAMINATION IS REQUESTED**

A detailed explanation pointing out the relevance and application of the prior art references to each of claims 18 and 27 is provided below. The charts below indicate what the Patent Owner believes are the portions of the cited art most relevant to the elements of the claims for which reexamination is requested. The Patent Owner, however, reserves the right to take positions asserting and submit arguments explaining why various claim elements are not disclosed or suggested by the cited art.

**A. Claim 18**

`183 Patent Claim Language	Boie `388
18. A capacitive responsive electronic switching circuit comprising:	“The capacitive sensor of the invention comprises a thin, insulating surface covering a plurality of electrodes. The position of an object, such as a finger or hand-held stylus, with respect to the electrodes, is determined from the centroid of capacitance values measured at the electrodes. . . . The x and y coordinates of the centroid are calculated in a microcontroller from the measured capacitances.” Boie `388, col. 1:61-col. 2:5, Fig. 4.
an oscillator providing a periodic output signal having a predefined frequency;	“RF oscillator 408 provides an RF signal, for example, 100 kilohertz, to circuits 401, synchronous detector and filter 404 via inverter 410, and guard plane 411.” <i>Id.</i> at col. 3:67-col. 4:2, Fig. 4.
a plurality of input touch terminals defining adjacent areas on a dielectric substrate for an operator to provide inputs by proximity and touch; and	“The operational principle of the capacitive position sensor of the invention is shown in FIG. 1. Electrode array 100 is a square or rectangular array of electrodes 101 arranged in a grid pattern of rows and columns, as in an array of tiles. . . . The electrodes are covered with a thin layer of insulating material (not shown). . . . Histogram 110 shows the capacitances for electrodes 101 in array 100 with respect to finger 102.” <i>Id.</i> at col.



`183 Patent Claim Language	Boie `388
	<p>2:49-62, Fig. 1.</p> <p>“FIG. 2 shows four such subdivided electrodes in more detail at an intersection of two rows and two columns in array 100. As can be seen from FIG. 2, a horizontal element 201 and a vertical element 202 are situated at each intersection of a row and column.” <i>Id.</i> at col. 3:16-20, Fig. 2.</p> <p>“As will be clear to those skilled in the art, elements 201 and 202 can be fabricated in one plane of a multi-layer printed circuit board together with one set of interconnections, for example, the horizontal row connections 203. The vertical row connections 204 can then be fabricated in another plane of the circuit board with appropriate via connections between the planes.” <i>Id.</i> at col. 3:30-36, Fig. 2.</p>
<p>a detector circuit coupled to said oscillator for receiving said periodic output signal from said oscillator, and coupled to said input touch terminals, said detector circuit being responsive to signals from said oscillator and the presence of an operator's body capacitance to ground coupled said touch terminals when proximal or touched by an operator to provide a control output signal,</p>	<p>“[E]ach row and column of electrodes from array 100 is connected to an integrating amplifier and bootstrap circuit 401, . . . Each of the outputs from circuits 401 can be selected by multiplexer 402 under control of microcontroller 406. The selected output is then forwarded to summing circuit 403, where such output is combined with a signal from trimmer resistor 409. Synchronous detector and filter 404 convert the output from summing circuit 403 to a signal related to the capacitance of the row or column selected by multiplexer 402. RF oscillator 408 provides an RF signal, for example, 100 kilohertz, to circuits 401, synchronous detector and filter 404 via inverter 410, and guard plane 411.” <i>Id.</i> at col. 3:53-col. 4:2, Fig. 4.</p> <p>“The output of synchronous detector and filter 404 is converted to digital form by analog-to-digital converter 405 and forwarded to microcontroller 406. Thus, microcontroller 406 can obtain a digital value representing the capacitance seen by any row or column of electrode elements (or electrode if measured</p>

`183 Patent Claim Language	Boie `388
	<p>separately) selected by multiplexer 402. . . . Microcontroller 406 sends data to utilizing means, such as a personal computer (not shown) over lead 420.” <i>Id.</i> at col. 4:21-32, Fig. 4.</p>
<p>wherein said predefined frequency of said oscillator is selected to decrease the impedance of said dielectric substrate relative to the impedance of any contaminate that may create an electrical path on said dielectric substrate between said adjacent areas, and</p> <p>wherein said detector circuit compares the sensed body capacitance to ground proximate an input touch terminal to a threshold level to prevent inadvertent generation of the control output signal.</p>	<p>“RF oscillator 408 provides an RF signal, for example, 100 kilohertz, to circuits 401, synchronous detector and filter 404 via inverter 410, and guard plane 411.” <i>Id.</i> at col. 3:67-col. 4:2, Fig. 4.</p> <p>“The effects of electrode-to-electrode capacitances, wiring capacitances and other extraneous capacitances are minimized by driving all electrodes and guard plane 411 in unison with the same RF signal from RF oscillator 408.” <i>Id.</i> at col. 4:58-61.</p> <p>“Referring to FIG. 6, microcomputer 406 reads the initial capacitance values for all the elements in array 100 and stores such values (step 601). Such initial values should reflect the state of array 100 without a finger or other object being nearby, accordingly, it may be desirable to repeat step 601 a number of times and then to select the minimum capacitance values read as the initial values, thereby compensating for the effect of any objects moving close to array 100 during the initialization step. After initialization, all capacitance values are periodically read and the initial values subtracted to yield a remainder value for each element (step 602). If one or more of the remainders exceeds a preset threshold (step 603), indicating that an object is close to or touching array 100, then the x and y coordinates of the centroid of capacitance for such object can be calculated from such remainders (step 604). . . . To avoid spurious operation, it may be desirable to require that two or more measurements exceed the preset threshold. The threshold can be set to some percentage of the range of A/D converter 405, for example 10-15% of such range.” <i>Id.</i> at col. 5:10-48, Fig. 6.</p>

**B. Claim 27**

`183 Patent Claim Language	Boie `388
<p>27. A capacitive responsive electronic switching circuit for a controlled device comprising:</p>	<p>“The capacitive sensor of the invention comprises a thin, insulating surface covering a plurality of electrodes. The position of an object, such as a finger or hand-held stylus, with respect to the electrodes, is determined from the centroid of capacitance values measured at the electrodes. . . . The x and y coordinates of the centroid are calculated in a microcontroller from the measured capacitances.” Boie `388, col. 1:61-col. 2:5, Fig. 4.</p> <p>“A computer input device for use as a computer mouse or keyboard comprises a thin, insulating surface covering an array of electrodes. . . . For applications in which the input device is used as a mouse, the microcontroller forwards position change information to the computer. For applications in which the input device is used as a keyboard, the microcomputer identifies a key from the position of the touching object and forwards such key identity to the computer.” <i>Id.</i> at Abstract.</p>
<p>an oscillator providing a periodic output signal having a predefined frequency;</p>	<p>“RF oscillator 408 provides an RF signal, for example, 100 kilohertz, to circuits 401, synchronous detector and filter 404 via inverter 410, and guard plane 411.” <i>Id.</i> at col. 3:67-col. 4:2, Fig. 4.</p>
<p>first and second touch terminals defining areas for an operator to provide an input by proximity and touch; and</p>	<p>“The operational principle of the capacitive position sensor of the invention is shown in FIG. 1. Electrode array 100 is a square or rectangular array of electrodes 101 arranged in a grid pattern of rows and columns, as in an array of tiles. . . . The electrodes are covered with a thin layer of insulating material (not shown). . . . Histogram 110 shows the capacitances for electrodes 101 in array 100 with respect to finger 102.” <i>Id.</i> at col. 2:49-62, Fig. 1.</p> <p>“FIG. 2 shows four such subdivided electrodes in more detail at an intersection of two rows and</p>

`183 Patent Claim Language	Boie `388
	<p>two columns in array 100. As can be seen from FIG. 2, a horizontal element 201 and a vertical element 202 are situated at each intersection of a row and column.” <i>Id.</i> at col. 3:16-20, Fig. 2.</p> <p>“As will be clear to those skilled in the art, elements 201 and 202 can be fabricated in one plane of a multi-layer printed circuit board together with one set of interconnections, for example, the horizontal row connections 203. The vertical row connections 204 can then be fabricated in another plane of the circuit board with appropriate via connections between the planes.” <i>Id.</i> at col. 3:30-36, Fig. 2.</p>
<p>a detector circuit coupled to said oscillator for receiving said periodic output signal from said oscillator, and coupled to said first and second touch terminals, said detector circuit being responsive to signals from said oscillator and the presence of an operator's body capacitance to ground coupled to said first and second touch terminals when proximal or touched by an operator to provide a control output signal for actuation of the controlled device,</p>	<p>“[E]ach row and column of electrodes from array 100 is connected to an integrating amplifier and bootstrap circuit 401, . . . Each of the outputs from circuits 401 can be selected by multiplexer 402 under control of microcontroller 406. The selected output is then forwarded to summing circuit 403, where such output is combined with a signal from trimmer resistor 409. Synchronous detector and filter 404 convert the output from summing circuit 403 to a signal related to the capacitance of the row or column selected by multiplexer 402. RF oscillator 408 provides an RF signal, for example, 100 kilohertz, to circuits 401, synchronous detector and filter 404 via inverter 410, and guard plane 411.” <i>Id.</i> at col. 3:53-col. 4:2, Fig. 4.</p> <p>“The output of synchronous detector and filter 404 is converted to digital form by analog-to-digital converter 405 and forwarded to microcontroller 406. Thus, microcontroller 406 can obtain a digital value representing the capacitance seen by any row or column of electrode elements (or electrode if measured separately) selected by multiplexer 402. . . . Microcontroller 406 sends data to utilizing means, such as a personal computer (not shown) over lead 420.” <i>Id.</i> at col. 4:21-32, Fig. 4.</p>

`183 Patent Claim Language	Boie `388
<p>said detector circuit being configured to generate said control output signal when an operator is proximal or touches said second touch terminal after the operator is proximal or touches said first touch terminal.</p>	<p>“A computer input device for use as a computer mouse or keyboard comprises a thin, insulating surface covering an array of electrodes. . . . For applications in which the input device is used as a mouse, the microcontroller forwards position change information to the computer. For applications in which the input device is used as a keyboard, the microcomputer identifies a key from the position of the touching object and forwards such key identity to the computer.” <i>Id.</i> at Abstract.</p> <p>“In using the position sensor of the invention as a computer mouse or trackball to control a cursor, movement of the mouse or trackball is emulated by touching array 100 with finger 102, or some other object, and stroking finger 102 over array 100 to move the cursor. Changes in position of the finger with respect to array 100 are reflected in corresponding changes in position of the cursor. Thus, for such an application, microcontroller 406 sends data over lead 420 relating to changes in position. FIG. 6 is a flow chart of the operation of microcontroller 406 in such an application.” <i>Id.</i> at col. 4:67-col. 5:9, Fig. 6.</p>

**IV. CONCLUSION**

A substantial new question of patentability is raised based on the newly cited prior art, and therefore a reexamination of claims 18 and 27 is warranted. Again, the Patent Owner reserves the right to take positions asserting and submit arguments explaining why various claim elements are not disclosed or suggested by the cited art.

If the Office should have any questions, please contact the undersigned attorney. The Commissioner is hereby authorized to charge any fees due in connection with this filing, or credit any overpayment, to Deposit Account No. 50-1065.

Respectfully submitted,

August 17, 2012  
Date

/Brian A. Carlson/  
Brian A. Carlson  
Reg. No. 37,793

Slater & Matsil, L.L.P.  
17950 Preston Rd.  
Suite 1000  
Dallas, TX 75252  
972-732-1001  
972-732-9218 (fax)



UNITED STATES PATENT AND TRADEMARK OFFICE

UNITED STATES DEPARTMENT OF COMMERCE  
United States Patent and Trademark Office  
Address: COMMISSIONER FOR PATENTS  
P.O. Box 1450  
Alexandria, Virginia 22313-1450  
www.uspto.gov

REEXAM CONTROL NUMBER	FILING OR 371 (c) DATE	PATENT NUMBER
90/012,439	08/17/2012	5796183

22045  
BROOKS KUSHMAN P.C.  
1000 TOWN CENTER  
TWENTY-SECOND FLOOR  
SOUTHFIELD, MI 48075

**CONFIRMATION NO. 4155  
REEXAMINATION REQUEST  
NOTICE**

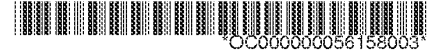

Date Mailed: 08/24/2012

**NOTICE OF REEXAMINATION REQUEST FILING DATE**  
**(Patent Owner Requester)**

Requester is hereby notified that the filing date of the request for reexamination is 08/17/2012, the date the required fee of \$2,520 was received. (See CFR 1.510(d)).

A decision on the request for reexamination will be mailed within three months from the filing date of the request for reexamination. (See 37 CFR 1.515(a)).

Pursuant to 37 CFR 1.33(c), future correspondence in this reexamination proceeding will be with the latest attorney or agent of the record in the patent file.

The paragraphs checked below are part of this communication:

- 1. The party receiving the courtesy copy is the latest attorney or agent of record in the patent file.
- 2. The person named to receive the correspondence in this proceeding has not been made the latest attorney or agent of record in the patent file because:
  - A. Requester's claim of ownership of the patent is not verified by the record.
  - B. The request papers are not signed with a real or apparent binding signature.
  - C. The mere naming of a correspondence addressee does not result in that person being appointed as the latest attorney or agent of record in the patent file.
- 3. Addressee is the latest attorney or agent of record in the patent file.
- 4. Other \_\_\_\_\_

/sdstevenson/

\_\_\_\_\_  
Legal Instruments Examiner  
Central Reexamination Unit 571-272-7705; FAX No. 571-273-9900



UNITED STATES PATENT AND TRADEMARK OFFICE

UNITED STATES DEPARTMENT OF COMMERCE  
United States Patent and Trademark Office  
Address: COMMISSIONER FOR PATENTS  
P.O. Box 1450  
Alexandria, Virginia 22313-1450  
www.uspto.gov

APPLICATION NO.	FILING DATE	FIRST NAMED INVENTOR	ATTORNEY DOCKET NO.	CONFIRMATION NO.
90/012,439	08/17/2012	5796183	5796183RX	4155

22045 7590 09/20/2012  
BROOKS KUSHMAN P.C.  
1000 TOWN CENTER  
TWENTY-SECOND FLOOR  
SOUTHFIELD, MI 48075

EXAMINER

NGUYEN, LINH M

ART UNIT	PAPER NUMBER
3992	

MAIL DATE	DELIVERY MODE
09/20/2012	PAPER

Please find below and/or attached an Office communication concerning this application or proceeding.

The time period for reply, if any, is set in the attached communication.



<b>Order Granting / Denying Request For Ex Parte Reexamination</b>	Control No.	Patent Under Reexamination
	90/012,439	5796183
	Examiner	Art Unit
	LINH M. NGUYEN	3992

*--The MAILING DATE of this communication appears on the cover sheet with the correspondence address--*

The request for *ex parte* reexamination filed 17 August 2012 has been considered and a determination has been made. An identification of the claims, the references relied upon, and the rationale supporting the determination are attached.

Attachments: a)  PTO-892,      b)  PTO/SB/08,      c)  Other: \_\_\_\_\_

1.  The request for *ex parte* reexamination is GRANTED.

**RESPONSE TIMES ARE SET AS FOLLOWS:**

For Patent Owner's Statement (Optional): **TWO MONTHS** from the mailing date of this communication (37 CFR 1.530 (b)). **EXTENSIONS OF TIME ARE GOVERNED BY 37 CFR 1.550(c).**

For Requester's Reply (optional): **TWO MONTHS** from the **date of service** of any timely filed Patent Owner's Statement (37 CFR 1.535). **NO EXTENSION OF THIS TIME PERIOD IS PERMITTED.** If Patent Owner does not file a timely statement under 37 CFR 1.530(b), then no reply by requester is permitted.

2.  The request for *ex parte* reexamination is DENIED.

This decision is not appealable (35 U.S.C. 303(c)). Requester may seek review by petition to the Commissioner under 37 CFR 1.181 within **ONE MONTH** from the mailing date of this communication (37 CFR 1.515(c)). **EXTENSION OF TIME TO FILE SUCH A PETITION UNDER 37 CFR 1.181 ARE AVAILABLE ONLY BY PETITION TO SUSPEND OR WAIVE THE REGULATIONS UNDER 37 CFR 1.183.**

In due course, a refund under 37 CFR 1.26 ( c ) will be made to requester:

- a)  by Treasury check or,
- b)  by credit to Deposit Account No. \_\_\_\_\_, or
- c)  by credit to a credit card account, unless otherwise notified (35 U.S.C. 303(c)).

--	--	--

cc: Requester ( if third party requester )

## DECISION

A substantial new question (SNQ) of patentability affecting claims 18 and 27 of United States Patent Number 5,796,183 ("the base patent" or "the 183' patent") is raised by the request for *ex parte* reexamination.

### *Information Disclosure Statement*

The Information Disclosure Statement submission of August 17, 2012 has been considered. It is to be noted, however, that where patents, publications, and other such items of information are submitted by a patent owner in compliance with the requirements of the rules, **the requisite degree of consideration to be given to such information will be limited by the degree to which the patent owner has explained the content and relevance of the information.** In instances where no explanation of citations (items of information) is required and none is provided for an information citation, only a cursory review of that information is required. The examiner need only perform a cursory evaluation of each unexplained item of information, to the extent that he/she needs in order to determine whether he/she will evaluate the item further. If the cursory evaluation reveals the item not to be useful, the examiner may simply stop looking at it. This review may often take the form of considering the documents in the same manner as other documents in Office search files are considered by the examiner while conducting a search of the prior art in a proper field of search. **The initials of the examiner, in this proceeding, placed adjacent to the citations on the PTO-1449 or PTO/SB/08A and 08B or its equivalent, without an indication in the record to the contrary in the record, do not**

Art Unit: 3992

signify that the information has been considered by the examiner any further than to the extent noted above. See MPEP 609, seventh paragraph, Revision 5, Aug. 2006 [page 600-141].

### *References*

Boie et al., U.S. Patent No. 5,463,388, filed on January 29, 1993 and issued on October 31, 1996 ("Boie '388").

### *Prosecution History*

The base patent stems from United States Patent Application No. 08/601,268 (hereinafter "the base application").

The examiner generally agrees with the description of the prosecution history found in the Request at pp. 5-7, and that discussion is incorporated by reference. The base application was ultimately allowed without a statement of reasons for allowance. From the prosecution history, it appears likely that claims 18 and 27 were allowed in the base application because of the amendatory language in claim 18 and the new independent claim 27, as discussed at page 6-7 of the Request.

*Proposed Rejections*

Under 35 U.S.C. 102(a)

Claims 18 and 27 of the '183 patent are unpatentable under 35 U.S.C. § 102(a) as being anticipated by Boie '388.

*Analysis of the Prior Art Provided in the Request*

*35 U.S.C. 102(a)*

**Boie '388:**

It is agreed that Boie '388 raises SNQ for claims 18 and 27 of the '183 patent. Insofar as the explanation at pages 8-12 of the Request and the item-matching at page 12-17 of Claim Chart of the Request at least facially suggest that Boie '388 teaches a substantial number of claimed features. A reasonable examiner would consider that Boie '388 important in deciding whether or not claims 18 and 27 of the '183 patent are patentable. Accordingly, Boie '388 raises a substantial new question of patentability as to claims 18 and 27, which question has not been decided in a previous examination of the '306 patent.

Such teachings are not cumulative to any written discussion on the record of the teachings of the prior art, were not previously considered nor addressed during a prior examination and the same question of patentability was not the subject of a final holding of invalidity by Federal Courts.

Art Unit: 3992

*Correspondence*

All correspondence relating to this *ex parte* reexamination proceeding should be directed:

By Mail to: Mail Stop *Ex Parte* Reexam  
Central Reexamination Unit  
Commissioner for Patents  
United States Patent & Trademark Office  
P.O. Box 1450  
Alexandria, VA 22313-1450

By FAX to: (571) 273-9900  
Central Reexamination Unit

By hand: Customer Service Window  
Randolph Building  
401 Dulany Street  
Alexandria, VA 22314

Registered users of EFS-Web may alternatively submit such correspondence via the electronic filing system EFS-Web, at <https://efs.uspto.gov/efile/myportal/efs-registered>. EFS-Web offers the benefit of quick submission to the particular area of the Office that needs to act on the correspondence. Also, EFS-Web submissions are "soft scanned" (i.e., electronically uploaded) directly into the official file for the reexamination proceeding, which offers parties the opportunity to review the content of their submissions after the "soft scanning" process is complete.

Any inquiry concerning this communication should be directed to Linh M. Nguyen at telephone number 571-272-1749.

Signed:

/Linh M. Nguyen/  
Primary Examiner  
Central Reexamination Unit 3992

Conferees:

/Margaret Rubin/

Primary Examiner CRU 3992

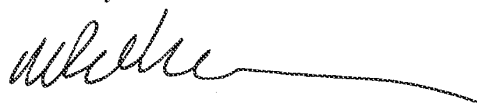
  
MARK J. REINHART  
Supervisory Patent Reexamination Specialist  
CRU -- Art Unit 3992

## Electronic Acknowledgement Receipt

<b>EFS ID:</b>	14267867
<b>Application Number:</b>	90012439
<b>International Application Number:</b>	
<b>Confirmation Number:</b>	4155
<b>Title of Invention:</b>	Capacitive Responsive Electronic Switching Circuit
<b>First Named Inventor/Applicant Name:</b>	5796183
<b>Customer Number:</b>	25962
<b>Filer:</b>	Brian A. Carlson/Michelle Hatcher
<b>Filer Authorized By:</b>	Brian A. Carlson
<b>Attorney Docket Number:</b>	NAR-5796183RX
<b>Receipt Date:</b>	19-NOV-2012
<b>Filing Date:</b>	17-AUG-2012
<b>Time Stamp:</b>	17:13:34
<b>Application Type:</b>	Reexam (Patent Owner)

### Payment information:

Submitted with Payment	yes
Payment Type	Deposit Account
Payment was successfully received in RAM	\$436
RAM confirmation Number	5429
Deposit Account	501065
Authorized User	

The Director of the USPTO is hereby authorized to charge indicated fees and credit any overpayment as follows:

- Charge any Additional Fees required under 37 C.F.R. Section 1.16 (National application filing, search, and examination fees)
- Charge any Additional Fees required under 37 C.F.R. Section 1.17 (Patent application and reexamination processing fees)

**File Listing:**

Document Number	Document Description	File Name	File Size(Bytes)/ Message Digest	Multi Part /.zip	Pages (if appl.)
1	Reexam Timely Patent Owner's Stmt in Resp to Order	NAR_5796183RX_PatentOwner Statement.pdf	162005 <small>859f817488b66572996fed7faf3874996251a6c</small>	no	37

**Warnings:****Information:**

2	Fee Worksheet (SB06)	fee-info.pdf	31575 <small>49b7d87fe9985d4a57903154d3764c47396547d</small>	no	2
---	----------------------	--------------	---	----	---

**Warnings:****Information:**

<b>Total Files Size (in bytes):</b>	193580
-------------------------------------	--------

This Acknowledgement Receipt evidences receipt on the noted date by the USPTO of the indicated documents, characterized by the applicant, and including page counts, where applicable. It serves as evidence of receipt similar to a Post Card, as described in MPEP 503.

**New Applications Under 35 U.S.C. 111**

If a new application is being filed and the application includes the necessary components for a filing date (see 37 CFR 1.53(b)-(d) and MPEP 506), a Filing Receipt (37 CFR 1.54) will be issued in due course and the date shown on this Acknowledgement Receipt will establish the filing date of the application.

**National Stage of an International Application under 35 U.S.C. 371**

If a timely submission to enter the national stage of an international application is compliant with the conditions of 35 U.S.C. 371 and other applicable requirements a Form PCT/DO/EO/903 indicating acceptance of the application as a national stage submission under 35 U.S.C. 371 will be issued in addition to the Filing Receipt, in due course.

**New International Application Filed with the USPTO as a Receiving Office**

If a new international application is being filed and the international application includes the necessary components for an international filing date (see PCT Article 11 and MPEP 1810), a Notification of the International Application Number and of the International Filing Date (Form PCT/RO/105) will be issued in due course, subject to prescriptions concerning national security, and the date shown on this Acknowledgement Receipt will establish the international filing date of the application.

IN THE UNITED STATES PATENT AND TRADEMARK OFFICE

U.S. Patent No.:	5,796,183 B1	§	Docket No.:	NAR-5796183RX
Issued:	August 18, 1998	§	Inventors:	Hourmand et al.
Filed:	January 31, 1996	§	Patent Owner:	UUSI, LLC
Control No.	TBD	§	Examiner:	Nguyen, Linh M.

For: Capacitive Responsive Electronic Switching Circuit

Mail Stop *Ex Parte* Reexam  
Attn: Central Reexamination Unit  
Commissioner for Patents  
P.O. Box 1450  
Alexandria, VA 22313-1450

PATENT OWNER STATEMENT

Dear Sir:

Patent Owner respectfully submits this Patent Owner Statement in response to the September 20, 2012 Order Granting Request for *Ex Parte* Reexamination of U.S. Patent Number 5,796,183 B1 (the “183 Patent”). Patent Owner respectfully requests that the following amendments and remarks be entered, and respectfully requests consideration of amended claims 18, 27, 28 and 32, and newly-added claims 33-39.



1. Listing Of The `183 Patent Claims Under Reexamination

A listing of each claim under reexamination is provided below. Reexamination of claims 18 and 27 was granted in the Order dated September 20, 2012. Accordingly, please amend claims 18 and 27, as well claims 28 and 32, which depend from claim 27, as provided below. In addition, please add new claims 33-39 as follows.

18. (Amended) A capacitive responsive electronic switching circuit comprising:  
an oscillator providing a periodic output signal having a predefined frequency;  
a microcontroller using the periodic output signal from the oscillator, the microcontroller selectively providing signal output frequencies to a plurality of small sized input touch terminals of a keypad;

[a] the plurality of small sized input touch terminals defining adjacent areas on a dielectric substrate for an operator to provide inputs by proximity and touch; and

a detector circuit coupled to said oscillator for receiving said periodic output signal from said oscillator, and coupled to said input touch terminals, said detector circuit being responsive to signals from said oscillator via said microcontroller and [the] a presence of an operator's body capacitance to ground coupled to said touch terminals when proximal or touched by [an] the operator to provide a control output signal,

wherein said predefined frequency of said oscillator [is] and said signal output frequencies are selected to decrease [the] a first impedance of said dielectric substrate relative to [the] a second impedance of any contaminate that may create an electrical path on said dielectric substrate between said adjacent areas defined by the plurality of small sized input touch terminals, and wherein said detector circuit compares [the] a sensed body capacitance change to

ground proximate an input touch terminal to a threshold level to prevent inadvertent generation of the control output signal.

27. (Amended) A capacitive responsive electronic switching circuit for a controlled keypad device comprising:

an oscillator providing a periodic output signal having a predefined frequency;

a microcontroller using the periodic output signal from the oscillator, the microcontroller selectively providing signal output frequencies to a closely spaced array of input touch terminals of a keypad, the input touch terminals comprising first and second input touch terminals;

the first and second input touch terminals defining areas for an operator to provide an input by proximity and touch; and

a detector circuit coupled to said oscillator for receiving said periodic output signal from said oscillator, and coupled to said first and second touch terminals, said detector circuit being responsive to signals from said oscillator via said microcontroller and [the] a presence of an operator's body capacitance to ground coupled to said first and second touch terminals when proximal or touched by [an] the operator to provide a control output signal for actuation of the controlled keypad device, said detector circuit being configured to generate said control output signal when [an] the operator is proximal or touches said second touch terminal after the operator is proximal or touches said first touch terminal.

28. (Amended) The capacitive responsive electronic switching circuit as defined in claim 27, wherein said detector circuit generates said control signal only when [an] the operator is proximal or touches said second touch terminal within a predetermined time period after the operator is proximal or touches said first touch terminal.

32. (Amended) The capacitive responsive electronic switching circuit as defined in claim 27 and further including an indicator for indicating when said detector circuit determines that [an] the operator is proximal or touches said first touch terminal.

33. (New) The capacitive responsive electronic switching circuit as defined in claim 18, further comprising wherein said detector circuit compares the sensed body capacitance change caused by the body capacitance decreasing an input touch terminal signal on the detector to ground when proximate to the input touch terminal to a second threshold level to generate the control output signal.

34. (New) The capacitive responsive electronic switching circuit as defined in claim 18, further comprising wherein said detector circuit compares the sensed body capacitance change caused by the body capacitance decreasing an input touch terminal signal amplitude on the detector to ground when proximate to the input touch terminal to a second threshold level to generate the control output signal.

35. (New) The capacitive responsive electronic switching circuit as defined in claim 27, wherein when the second touch terminal is not touched on its defining area by the operator to provide input, the control output signal is prevented.

36. (New) The capacitive responsive electronic switching circuit as defined in claim 27 and further including an indicator for indicating when said detector circuit determines that the operator is proximal or touches said second touch terminal.

37. (New) A capacitive responsive electronic switching circuit for a controlled device

comprising:

an oscillator providing a periodic output signal having a predefined frequency, wherein an oscillator voltage is greater than a supply voltage;

a microcontroller using the periodic output signal from the oscillator, the microcontroller selectively providing signal output frequencies to a closely spaced array of input touch terminals of a keypad, the input touch terminals comprising first and second input touch terminals;

the first and second touch terminals defining areas for an operator to provide an input by proximity and touch; and

a detector circuit coupled to said oscillator for receiving said periodic output signal from said oscillator, and coupled to said first and second touch terminals, said detector circuit being responsive to signals from said oscillator via said microcontroller and a presence of an operator's body capacitance to ground coupled to said first and second touch terminals when proximal or touched by the operator to provide a control output signal for actuation of the controlled device, said detector circuit being configured to generate said control output signal when the operator is proximal or touches said second touch terminal after the operator is proximal or touches said first touch terminal.

38. (New) The capacitive responsive electronic switching circuit as defined in claim 37, wherein feedback to the operator is provided by an indicator activated by the microcontroller after the operator touches the second touch terminal.

39. (New) The capacitive responsive electronic switching circuit as defined in claim 37,

wherein said detector circuit compares a sensed body capacitance change caused by the

body capacitance decreasing a second touch terminal signal on the detector to ground when proximate to the second touch terminal to a threshold level to generate the control output signal, and

wherein feedback to the operator is provided by an indicator activated by the microcontroller after the operator touches the second touch terminal.

## II. Status of the Claims

Claims 1-39 are pending in the present reexamination proceeding, of which claims 18, 27, 28 and 32 are amended herein and 33-39 are added herein.

## III. Discussion of Claims and Prior Art Reference

Patent Owner filed a Request for *Ex Parte* Reexamination on August 17, 2012, submitting that a substantial new question of patentability of claims 18 and 27 is raised by Boie et al., U.S. Patent No. 5,463,388 (“Boie”). Reexamination of these claims was granted in the Order dated September 20, 2012.

Patent Owner is amending claims 18 and 27 in this Patent Owner Statement. Because some of these amendments were made to provide better antecedent basis for some claim terms, Patent Owner is amending dependent claims 28 and 32 for the same reason. Patent Owner also is adding new claims 33-39. Accordingly, Patent Owner respectfully requests consideration of amended claims 18, 27, 28 and 32, and new claims 33-39. No new matter has been added.

### **A. Independent Claim 18**

Independent claim 18 recites “a microcontroller using the periodic output signal from the oscillator, the microcontroller selectively providing signal output frequencies to a plurality of small sized input touch terminals of a keypad.” Boie does not teach or suggest these claim elements.

Rather, Boie discloses that “RF oscillator 408 provides an RF signal, for example, 100 kilohertz, to circuits 401, synchronous detector and filter 404 via inverter 410, and guard plane 411.” Boie, col. 3:67-col. 4:2. Boie further discloses that “[t]he effects of electrode-to-electrode

capacitances, wiring capacitances and other extraneous capacitances are minimized by driving all electrodes and guard plane 411 in unison with the same RF signal from RF oscillator 408.” *Id.* at col. 4:58-60 (emphasis added); *see id.* at Fig. 4. Thus Boie discloses driving the electrodes of electrode array 100 and guard plane 411 with a single RF signal. Boie does not teach or suggest providing signal output frequencies to these components. Accordingly, Boie does not disclose all of the elements of claim 18, and therefore claim 18 is patentable over Boie.

New claims 33 and 34 depend from claim 18 and add further limitations. Patent Owner respectfully submits that these dependent claims are allowable by reason of depending from an allowable claim as well as for adding new limitations.

#### **B. Independent Claim 27**

Independent claim 27 recites “a microcontroller using the periodic output signal from the oscillator, the microcontroller selectively providing signal output frequencies to a closely spaced array of input touch terminals of a keypad, the input touch terminals comprising first and second input touch terminals.” Boie does not teach or suggest these claim elements.

Rather, Boie discloses that “RF oscillator 408 provides an RF signal, for example, 100 kilohertz, to circuits 401, synchronous detector and filter 404 via inverter 410, and guard plane 411.” Boie, col. 3:67-col. 4:2. Boie further discloses that “[t]he effects of electrode-to-electrode capacitances, wiring capacitances and other extraneous capacitances are minimized by driving all electrodes and guard plane 411 in unison with the same RF signal from RF oscillator 408.” *Id.* at col. 4:58-60 (emphasis added); *see id.* at Fig. 4. Thus Boie discloses driving the electrodes of electrode array 100 and guard plane 411 with a single RF signal. Boie does not teach or suggest

providing signal output frequencies to these components. Accordingly, Boie does not disclose all of the elements of claim 27, and therefore claim 27 is patentable over Boie.

Amended claims 28 and 32, and new claims 35-36, depend from claim 27 and add further limitations. Patent Owner respectfully submits that these dependent claims are allowable by reason of depending from an allowable claim as well as for adding new limitations.

### **C. Independent Claim 37**

Independent claim 37 recites “a microcontroller using the periodic output signal from the oscillator, the microcontroller selectively providing signal output frequencies to a closely spaced array of input touch terminals of a keypad, the input touch terminals comprising first and second input touch terminals.” Boie does not teach or suggest these claim elements.

Rather, Boie discloses that “RF oscillator 408 provides an RF signal, for example, 100 kilohertz, to circuits 401, synchronous detector and filter 404 via inverter 410, and guard plane 411.” Boie, col. 3:67-col. 4:2. Boie further discloses that “[t]he effects of electrode-to-electrode capacitances, wiring capacitances and other extraneous capacitances are minimized by driving all electrodes and guard plane 411 in unison with the same RF signal from RF oscillator 408.” *Id.* at col. 4:58-60 (emphasis added); *see id.* at Fig. 4. Thus Boie discloses driving the electrodes of electrode array 100 and guard plane 411 with a single RF signal. Boie does not teach or suggest providing signal output frequencies to these components.

Independent claim 37 further recites “an oscillator providing a periodic output signal having a predefined frequency, wherein an oscillator voltage is greater than a supply voltage.” Boie is silent regarding an oscillator voltage being greater than a supply voltage.



For at least the above reasons, Boie does not disclose all of the elements of claim 37, and therefore claim 37 is patentable over Boie.

New claims 38-39 depend from claim 37 and add further limitations. Patent Owner respectfully submits that these dependent claims are allowable by reason of depending from an allowable claim as well as for adding new limitations.

**IV. Support for Claim Amendments and New Claims**

Support for each of the amendments to claims 18, 27, 28 and 32, and for new claims 33-39, may be found throughout the `183 Patent, and particular support may be found, for example, as set forth in the charts below.

**A. Amended Claim 18**

`183 Patent Claim Language	`183 Patent Support
18. A capacitive responsive electronic switching circuit comprising:	--
an oscillator providing a periodic output signal having a predefined frequency;	--
<u>a microcontroller using the periodic output signal from the oscillator, the microcontroller selectively providing signal output frequencies to a plurality of small sized input touch terminals of a keypad;</u>	<p>See Figures 4, 11; and Claims 8, 12, 16.</p> <p>The `183 Patent discloses “The touch detection circuit of the present invention features operation at frequencies at or above 50kHz and preferably at or above 800 kHz to minimize the effects of surface contamination for materials such a skin oils and water. It also offers improvements in detection sensitivity that allow close control of the degree of proximity (ideally very close proximity) that is required for actuation and to enable employment of a multiplicity of small size touch terminals in a physical close array such as a keyboard.” Col. 5:49-57.</p> <p>The `183 Patent discloses “In a first preferred embodiment the circuit offers enhanced detection sensitivity to allow reliable operation with small (finger size) touch pads.” Col. 6:1-3.</p> <p>The `183 Patent discloses “Although the preferred frequency is at or above 100 kHz, and more preferably at or above 800 kHz, it is conceivable that frequencies as low as 50 kHz could be used provided the frequency creates a difference in the impedance paths of adjacent pads that is sufficient enough to accurately</p>

`183 Patent Claim Language	`183 Patent Support
	<p>distinguish between an intended touch and the touch of an adjacent pad. Use of frequencies as low as 50 kHz may also be possible depending upon the type of glass or covering or the thickness thereof used for the touch pad.” Col. 11:19-27.</p> <p>The `183 Patent discloses “Upon being powered by voltage regulator 100, oscillator 200 generates a square wave with a frequency of 50 kHz, and preferably greater than 800 kHz, and having an amplitude of 26 V peak. The square wave generated by oscillator 200 is supplied via line 201 to a floating common generator 300, a touch pad shield plate 460, a touch circuit 400, and a microcontroller 500. Oscillator 200 is described below with reference to FIG. 6. Floating common generator 300 receives the 26 V peak square wave from oscillator 200 and outputs a regulated floating common that is 5 volts below the square wave output from oscillator 200 and has the same phase and frequency as the received square wave. This floating common output is supplied to touch circuit 400 and microcontroller 500 via line 301 such that the output square wave from oscillator 200 and floating common output from floating common generator 300 provide power to touch circuit 400 and microcontroller 500. Details of floating common generator 300 are discussed below with reference to FIG. 7. Touch circuit 400 senses capacitance from a touch pad 450 via line 451 and outputs a signal to microcontroller 500 via line 401 upon detecting a capacitance to ground at touch pad 450 that exceeds a threshold value. The details of touch circuit 400 are described below with reference to FIG. 8. Upon receiving an indication from touch circuit 400 that a sufficient capacitance to ground (typically at least 20 pF) is present at touch pad 450, microcontroller 500 outputs a signal to a load-controlling microcontroller 600 via line 501, which is preferably a two way optical coupling bus.” Col. 12:6-33.</p>

`183 Patent Claim Language	`183 Patent Support
	<p>The `183 Patent discloses “As will be apparent to those skilled in the art, the values of the resistors and capacitors utilized in oscillator 200 may be varied from those disclosed above to provide for different oscillator output frequencies.” Col. 14:22-25.</p> <p>The `183 Patent discloses “A multiple touch pad circuit constructed in accordance with the second embodiment is shown in FIG. 11. In the second embodiment of FIG. 11, components similar to those in the first embodiment in FIG. 4 are designated with the same references numerals and will not be discussed in detail. The multiple touch pad circuit is a variation of the first embodiment in that it includes an array of touch circuits designated as 900<sub>1</sub> through 900<sub>nm</sub>, which, as shown, include both the touch circuit 400 shown in FIGS. 4 and 8 and the input touch terminal pad 451 (FIG. 4). Microcontroller 500 selects each row of the touch circuits 900<sub>1</sub> through 900<sub>nm</sub> by providing the signal from oscillator 200 to selected rows of touch circuits. In this manner, microcontroller 500 can sequentially activate the touch circuit rows and associate the received inputs from the columns of the array with the activated touch circuit(s). To keep the path length 451 between the touch pad 450 and the base to the detection transistor 410 to a minimum, the detection circuits 900 are physically located directly beneath the touch pads. To simplify assembly, a flexible circuit board such as vended by Sheldahl, Inc. or Circuit Etching Technics, Inc. can be used for this purpose. Ideally, the printed circuit will be fixed directly against the surface (typically glass) bearing the conductive touch pads to eliminate air gaps and the need for conductive foam pads and spring contacts which were used to fill air gaps.” Col. 18:34-59.</p>
[a] <u>the plurality of small sized</u> input touch terminals defining adjacent	See Figure 11.

`183 Patent Claim Language	`183 Patent Support
<p>areas on a dielectric substrate for an operator to provide inputs by proximity and touch; and</p>	<p>The `183 Patent discloses “It also offers improvements in detection sensitivity that allow close control of the degree of proximity (ideally very close proximity) that is required for actuation and to enable employment of a multiplicity of small size touch terminals in a physical close array such as a keyboard.” Col. 5:53-57.</p>
<p>a detector circuit coupled to said oscillator for receiving said periodic output signal from said oscillator, and coupled to said input touch terminals, said detector circuit being responsive to signals from said oscillator <u>via said microcontroller</u> and [the] a presence of an operator's body capacitance to ground coupled <u>to</u> said touch terminals when proximal or touched by [an] <u>the</u> operator to provide a control output signal,</p>	<p>See Figures 4, 11; and Claims 8, 12, 16.</p> <p>The `183 Patent discloses The `183 Patent discloses “Upon being powered by voltage regulator 100, oscillator 200 generates a square wave with a frequency of 50 kHz, and preferably greater than 800 kHz, and having an amplitude of 26 V peak. The square wave generated by oscillator 200 is supplied via line 201 to a floating common generator 300, a touch pad shield plate 460, a touch circuit 400, and a microcontroller 500. Oscillator 200 is described below with reference to FIG. 6.</p> <p>Floating common generator 300 receives the 26 V peak square wave from oscillator 200 and outputs a regulated floating common that is 5 volts below the square wave output from oscillator 200 and has the same phase and frequency as the received square wave. This floating common output is supplied to touch circuit 400 and microcontroller 500 via line 301 such that the output square wave from oscillator 200 and floating common output from floating common generator 300 provide power to touch circuit 400 and microcontroller 500. Details of floating common generator 300 are discussed below with reference to FIG. 7. Touch circuit 400 senses capacitance from a touch pad 450 via line 451 and outputs a signal to microcontroller 500 via line 401 upon detecting a capacitance to ground at touch pad 450 that exceeds a threshold value. The details of touch circuit 400 are described below with reference to FIG. 8.</p> <p>Upon receiving an indication from touch circuit 400 that a sufficient capacitance to ground</p>

`183 Patent Claim Language	`183 Patent Support
	<p>(typically at least 20 pF) is present at touch pad 450, microcontroller 500 outputs a signal to a load-controlling microcontroller 600 via line 501, which is preferably a two way optical coupling bus.” Col. 12:6-33.</p> <p>The `183 Patent discloses “A multiple touch pad circuit constructed in accordance with the second embodiment is shown in FIG. 11. In the second embodiment of FIG. 11, components similar to those in the first embodiment in FIG. 4 are designated with the same references numerals and will not be discussed in detail. The multiple touch pad circuit is a variation of the first embodiment in that it includes an array of touch circuits designated as 9001 through 900nm, which, as shown, include both the touch circuit 400 shown in FIGS. 4 and 8 and the input touch terminal pad 451 (FIG. 4). Microcontroller 500 selects each row of the touch circuits 9001 through 900nm by providing the signal from oscillator 200 to selected rows of touch circuits. In this manner, microcontroller 500 can sequentially activate the touch circuit rows and associate the received inputs from the columns of the array with the activated touch circuit(s). To keep the path length 451 between the touch pad 450 and the base to the detection transistor 410 to a minimum, the detection circuits 900 are physically located directly beneath the touch pads. To simplify assembly, a flexible circuit board such as vended by Sheldahl, Inc. or Circuit Etching Technics, Inc. can be used for this purpose. Ideally, the printed circuit will be fixed directly against the surface (typically glass) bearing the conductive touch pads to eliminate air gaps and the need for conductive foam pads and spring contacts which were used to fill air gaps.” Col. 18:34-59.</p>
<p>wherein said predefined frequency of said oscillator [is] <u>and said signal output frequencies are</u> selected to decrease [the] <u>a first impedance of said dielectric</u></p>	<p>See Figure 11; and Claims 12, 16.</p> <p>The `183 Patent discloses “Another method for implementing capacitive touch switches relies on</p>

`183 Patent Claim Language	`183 Patent Support
<p>substrate relative to [the] <u>a second impedance of any contaminate that may create an electrical path on said dielectric substrate between said adjacent areas defined by the plurality of small sized input touch terminals</u>, and wherein said detector circuit compares [the] <u>a sensed body capacitance change</u> to ground proximate an input touch terminal to a threshold level to prevent inadvertent generation of the control output signal.</p>	<p>the change in capacitive coupling between a touch terminal and ground. Systems utilizing such a method are described in U.S. Pat. No. 4,758,735 and U.S. Pat. No. 5,087,825. With this methodology the detection circuit consists of an oscillator (or AC line voltage derivative) providing a signal to a touch terminal whose voltage is then monitored by a detector. The touch terminal is driven in electrical series with other components that function in part as a charge pump. The touch of an operator then provides a capacitive short to ground via the operator's own body capacitance that lowers the amplitude of oscillator voltage seen at the touch terminal." Col. 3:44-56.</p> <p>The `183 Patent discloses "The touch detection circuit of the present invention features operation at frequencies at or above 50kHz and preferably at or above 800 kHz to minimize the effects of surface contamination for materials such a skin oils and water. It also offers improvements in detection sensitivity that allow close control of the degree of proximity (ideally very close proximity) that is required for actuation and to enable employment of a multiplicity of small size touch terminals in a physical close array such as a keyboard." Col. 5:49-57.</p> <p>The `183 Patent discloses "Although the preferred frequency is at or above 100 kHz, and more preferably at or above 800 kHz, it is conceivable that frequencies as low as 50 kHz could be used provided the frequency creates a difference in the impedance paths of adjacent pads that is sufficient enough to accurately distinguish between an intended touch and the touch of an adjacent pad. Us of frequencies as low as 50 kHz may also be possible depending upon the type of glass or covering or the thickness thereof used for the touch pad." Col. 11:19-27.</p> <p>The `183 Patent discloses "As will be apparent</p>

`183 Patent Claim Language	`183 Patent Support
	to those skilled in the art, the values of the resistors and capacitors utilized in oscillator 200 may be varied from those disclosed above to provide for different oscillator output frequencies.” Col. 14:22-25.

**B. Amended Claim 27**

`183 Patent Claim Language	`183 Patent Support
27. A capacitive responsive electronic switching circuit for a controlled <u>keypad</u> device comprising:	<p>The `183 Patent discloses “It also offers improvements in detection sensitivity that allow close control of the degree of proximity (ideally very close proximity) that is required for actuation and to enable employment of a multiplicity of small size touch terminals in a physical close array such as a keyboard,” Col. 5:53-57.</p> <p>The `183 Patent discloses “In a first preferred embodiment the circuit offers enhanced detection sensitivity to allow reliable operation with small (finger size) touch pads.” Col. 6:1-3.</p>
an oscillator providing a periodic output signal having a predefined frequency;	---
<u>a microcontroller using the periodic output signal from the oscillator, the microcontroller selectively providing signal output frequencies to a closely spaced array of input touch terminals of a keypad, the input touch terminals comprising first and second input touch terminals;</u>	<p>See Figures 4, 11; and Claims 8, 12, 16.</p> <p>The `183 Patent discloses “The touch detection circuit of the present invention features operation at frequencies at or above 50kHz and preferably at or above 800 kHz to minimize the effects of surface contamination for materials such a skin oils and water. It also offers improvements in detection sensitivity that allow close control of the degree of proximity (ideally very close proximity) that is required for actuation and to enable employment of a multiplicity of small size touch terminals in a physical close array such as a keyboard.” Col. 5:49-57.</p>



`183 Patent Claim Language	`183 Patent Support
	<p>The `183 Patent discloses “In a first preferred embodiment the circuit offers enhanced detection sensitivity to allow reliable operation with small (finger size) touch pads.” Col. 6:1-3.</p> <p>The `183 Patent discloses “Although the preferred frequency is at or above 100 kHz, and more preferably at or above 800 kHz, it is conceivable that frequencies as low as 50 kHz could be used provided the frequency creates a difference in the impedance paths of adjacent pads that is sufficient enough to accurately distinguish between an intended touch and the touch of an adjacent pad. Use of frequencies as low as 50 kHz may also be possible depending upon the type of glass or covering or the thickness thereof used for the touch pad.” Col. 11:19-27.</p> <p>The `183 Patent discloses “Upon being powered by voltage regulator 100, oscillator 200 generates a square wave with a frequency of 50 kHz, and preferably greater than 800 kHz, and having an amplitude of 26 V peak. The square wave generated by oscillator 200 is supplied via line 201 to a floating common generator 300, a touch pad shield plate 460, a touch circuit 400, and a microcontroller 500. Oscillator 200 is described below with reference to FIG. 6. Floating common generator 300 receives the 26 V peak square wave from oscillator 200 and outputs a regulated floating common that is 5 volts below the square wave output from oscillator 200 and has the same phase and frequency as the received square wave. This floating common output is supplied to touch circuit 400 and microcontroller 500 via line 301 such that the output square wave from oscillator 200 and floating common output from floating common generator 300 provide power to touch circuit 400 and microcontroller 500. Details of floating common generator 300 are discussed below with reference to FIG. 7. Touch circuit</p>

`183 Patent Claim Language	`183 Patent Support
	<p>400 senses capacitance from a touch pad 450 via line 451 and outputs a signal to microcontroller 500 via line 401 upon detecting a capacitance to ground at touch pad 450 that exceeds a threshold value. The details of touch circuit 400 are described below with reference to FIG. 8. Upon receiving an indication from touch circuit 400 that a sufficient capacitance to ground (typically at least 20 pF) is present at touch pad 450, microcontroller 500 outputs a signal to a load-controlling microcontroller 600 via line 501, which is preferably a two way optical coupling bus.” Col. 12:6-33.</p> <p>The `183 Patent discloses “As will be apparent to those skilled in the art, the values of the resistors and capacitors utilized in oscillator 200 may be varied from those disclosed above to provide for different oscillator output frequencies.” Col. 14:22-25.</p> <p>The `183 Patent discloses “A multiple touch pad circuit constructed in accordance with the second embodiment is shown in FIG. 11. In the second embodiment of FIG. 11, components similar to those in the first embodiment in FIG. 4 are designated with the same references numerals and will not be discussed in detail. The multiple touch pad circuit is a variation of the first embodiment in that it includes an array of touch circuits designated as 9001 through 900n, which, as shown, include both the touch circuit 400 shown in FIGS. 4 and 8 and the input touch terminal pad 451 (FIG. 4). Microcontroller 500 selects each row of the touch circuits 9001 through 900n by providing the signal from oscillator 200 to selected rows of touch circuits. In this manner, microcontroller 500 can sequentially activate the touch circuit rows and associate the received inputs from the columns of the array with the activated touch circuit(s). To keep the path length 451 between the touch pad 450 and the base to the detection transistor 410 to a minimum, the detection circuits 900 are</p>

`183 Patent Claim Language	`183 Patent Support
	<p>physically located directly beneath the touch pads. To simplify assembly, a flexible circuit board such as vended by Sheldahl, Inc. or Circuit Etching Technics, Inc. can be used for this purpose. Ideally, the printed circuit will be fixed directly against the surface (typically glass) bearing the conductive touch pads to eliminate air gaps and the need for conductive foam pads and spring contacts which were used to fill air gaps.” Col. 18:34-59.</p>
<p><u>the</u> first and second <u>input</u> touch terminals defining areas for an operator to provide an input by proximity and touch; and</p>	<p>See Figure 11.</p> <p>The `183 Patent discloses “A multiple touch pad circuit constructed in accordance with the second embodiment is shown in FIG. 11. In the second embodiment of FIG. 11, components similar to those in the first embodiment in FIG. 4 are designated with the same references numerals and will not be discussed in detail. The multiple touch pad circuit is a variation of the first embodiment in that it includes an array of touch circuits designated as 9001 through 900nm, which, as shown, include both the touch circuit 400 shown in FIGS. 4 and 8 and the input touch terminal pad 451 (FIG. 4).” Col. 18:34-43.</p>
<p>a detector circuit coupled to said oscillator for receiving said periodic output signal from said oscillator, and coupled to said first and second touch terminals, said detector circuit being responsive to signals from said oscillator <u>via said microcontroller</u> and [the] a presence of an operator's body capacitance to ground coupled to said first and second touch terminals when proximal or touched by [an] <u>the</u> operator to provide a control output signal for actuation of the controlled <u>keypad</u> device, said detector circuit being configured to generate said control output signal when [an] <u>the</u> operator is proximal or touches said second touch terminal after the operator is</p>	<p>See Figures 4, 11; and Claims 8, 12, 16.</p> <p>The `183 Patent discloses “It also offers improvements in detection sensitivity that allow close control of the degree of proximity (ideally very close proximity) that is required for actuation and to enable employment of a multiplicity of small size touch terminals in a physical close array such as a keyboard,” Col. 5:53-57.</p> <p>The `183 Patent discloses “In a first preferred embodiment the circuit offers enhanced detection sensitivity to allow reliable operation with small (finger size) touch pads.” Col. 6:1-3.</p> <p>The `183 Patent discloses “Upon being powered</p>

`183 Patent Claim Language	`183 Patent Support
<p>proximal or touches said first touch terminal.</p>	<p>by voltage regulator 100, oscillator 200 generates a square wave with a frequency of 50 kHz, and preferably greater than 800 kHz, and having an amplitude of 26 V peak. The square wave generated by oscillator 200 is supplied via line 201 to a floating common generator 300, a touch pad shield plate 460, a touch circuit 400, and a microcontroller 500. Oscillator 200 is described below with reference to FIG. 6. Floating common generator 300 receives the 26 V peak square wave from oscillator 200 and outputs a regulated floating common that is 5 volts below the square wave output from oscillator 200 and has the same phase and frequency as the received square wave. This floating common output is supplied to touch circuit 400 and microcontroller 500 via line 301 such that the output square wave from oscillator 200 and floating common output from floating common generator 300 provide power to touch circuit 400 and microcontroller 500. Details of floating common generator 300 are discussed below with reference to FIG. 7. Touch circuit 400 senses capacitance from a touch pad 450 via line 451 and outputs a signal to microcontroller 500 via line 401 upon detecting a capacitance to ground at touch pad 450 that exceeds a threshold value. The details of touch circuit 400 are described below with reference to FIG. 8. Upon receiving an indication from touch circuit 400 that a sufficient capacitance to ground (typically at least 20 pF) is present at touch pad 450, microcontroller 500 outputs a signal to a load-controlling microcontroller 600 via line 501, which is preferably a two way optical coupling bus.” Col. 12:6-33.</p> <p>The `183 Patent discloses “A multiple touch pad circuit constructed in accordance with the second embodiment is shown in FIG. 11. In the second embodiment of FIG. 11, components similar to those in the first embodiment in FIG. 4 are designated with the same references numerals and will not be discussed in detail. The multiple</p>

`183 Patent Claim Language	`183 Patent Support
	<p>touch pad circuit is a variation of the first embodiment in that it includes an array of touch circuits designated as 9001 through 900nm, which, as shown, include both the touch circuit 400 shown in FIGS. 4 and 8 and the input touch terminal pad 451 (FIG. 4). Microcontroller 500 selects each row of the touch circuits 9001 through 900nm by providing the signal from oscillator 200 to selected rows of touch circuits. In this manner, microcontroller 500 can sequentially activate the touch circuit rows and associate the received inputs from the columns of the array with the activated touch circuit(s). To keep the path length 451 between the touch pad 450 and the base to the detection transistor 410 to a minimum, the detection circuits 900 are physically located directly beneath the touch pads. To simplify assembly, a flexible circuit board such as vended by Sheldahl, Inc. or Circuit Etching Technics, Inc. can be used for this purpose. Ideally, the printed circuit will be fixed directly against the surface (typically glass) bearing the conductive touch pads to eliminate air gaps and the need for conductive foam pads and spring contacts which were used to fill air gaps.” Col. 18:34-59.</p>

**C. Amended Claim 28**

`183 Patent Claim Language	`183 Patent Support
<p>28. The capacitive responsive electronic switching circuit as defined in claim 27, wherein said detector circuit generates said control signal only when [an] <u>the</u> operator is proximal or touches said second touch terminal within a predetermined time period after the operator is proximal or touches said first touch terminal.</p>	<p>The amendment does not substantively change original claim 28.</p>

**D. Amended Claim 32**

`183 Patent Claim Language	`183 Patent Support
<p>32. The capacitive responsive electronic switching circuit as defined in claim 27 and further including an indicator for indicating when said detector circuit determines that [an] <u>the</u> operator is proximal or touches said first touch terminal.</p>	<p>The amendment does not substantively change original claim 32.</p>

**E. New Claim 33**

`183 Patent Claim Language	`183 Patent Support
<p>33. The capacitive responsive electronic switching circuit as defined in claim 18, further comprising wherein said detector circuit compares the sensed body capacitance change caused by the body capacitance decreasing an input touch terminal signal on the detector to ground when proximate to the input touch terminal to a second threshold level to generate the control output signal.</p>	<p>See Claims 1, 18, 28.</p> <p>The `183 Patent discloses “The touch detection circuit of the present invention features operation at frequencies at or above 50kHz and preferably at or above 800 kHz to minimize the effects of surface contamination for materials such a skin oils and water. It also offers improvements in detection sensitivity that allow close control of the degree of proximity (ideally very close proximity) that is required for actuation and to enable employment of a multiplicity of small size touch terminals in a physical close array such as a keyboard.” Col. 5:49-57.</p> <p>The `183 Patent discloses “Touch circuit 400 senses capacitance from a touch pad 450 via line 451 and outputs a signal to microcontroller 500 via line 401 upon detecting a capacitance to ground at touch pad 450 that exceeds a threshold value. The details of touch circuit 400 are described below with reference to FIG. 8.” Col. 12:24-28.</p>

F. New Claim 34

`183 Patent Claim Language	`183 Patent Support
<p>34. The capacitive responsive electronic switching circuit as defined in claim 18, further comprising wherein said detector circuit compares the sensed body capacitance change caused by the body capacitance decreasing an input touch terminal signal amplitude on the detector to ground when proximate to the input touch terminal to a second threshold level to generate the control output signal.</p>	<p>See Claims 1, 18, 28.</p> <p>The `183 Patent discloses “Another method for implementing capacitive touch switches relies on the change in capacitive coupling between a touch terminal and ground. Systems utilizing such a method are described in U.S. Pat. No. 4,758,735 and U.S. Pat. No. 5,087,825. With this methodology the detection circuit consists of an oscillator (or AC line voltage derivative) providing a signal to a touch terminal whose voltage is then monitored by a detector. The touch terminal is driven in electrical series with other components that function in part as a charge pump. The touch of an operator then provides a capacitive short to ground via the operator's own body capacitance that lowers the amplitude of oscillator voltage seen at the touch terminal.” Col. 3:44-56.</p> <p>The `183 Patent discloses “The touch detection circuit of the present invention features operation at frequencies at or above 50kHz and preferably at or above 800 kHz to minimize the effects of surface contamination for materials such a skin oils and water. It also offers improvements in detection sensitivity that allow close control of the degree of proximity (ideally very close proximity) that is required for actuation and to enable employment of a multiplicity of small size touch terminals in a physical close array such as a keyboard.” Col. 5:49-57.</p> <p>The `183 Patent discloses “Touch circuit 400 senses capacitance from a touch pad 450 via line 451 and outputs a signal to microcontroller 500 via line 401 upon detecting a capacitance to ground at touch pad 450 that exceeds a threshold value. The details of touch circuit 400 are described below with reference to FIG. 8.” Col. 12:24-28.</p>

**G. New Claim 35**

`183 Patent Claim Language	`183 Patent Support
<p>35. The capacitive responsive electronic switching circuit as defined in claim 27, wherein when the second touch terminal is not touched on its defining area by the operator to provide input, the control output signal is prevented.</p>	<p>See Figures 19, 20A-C; and Claim 28.</p> <p>The `183 Patent discloses “In another embodiment a method to prevent inadvertent so actuations is to require a multi-step process. Referring to FIG. 19, a device is shown having a first palm button 2201, a second palm button 2202, and an indicator light 2205. Palm button 2201 has to be activated first and then button 2202 has to be activated within a 2 second time window before a desired actuation can occur.” Col. 22:49-55.</p> <p>The `183 Patent discloses “In a variation of the multi-step process, two touch plates within a housing (one vertical and one horizontal) are used to provide a two-step turn-on. Referring to FIGS. 20A-C, the first step to actuate the output relay 2310, is initiated when the operator inserts his hands and touches the vertical touch sensor 2301 with the dorsal side of the hands. A yellow LED 2304 on top of the device show the successful completion of the first step. The second step is to flip the hand over and touch the horizontal touch sensor 2302 with the palmar side of the hand. A red LED 2305 on top of the device shows the completion of the two step turn-on and activation of output relay 2310. The flipping action of the hand in the second step causes the forearm muscles to flex, thereby reducing stiffness and fatigue. Also, the hands, and arms can rest on the run bar until the machine cycle is complete. The second step of the two-step turn-on must occur within some predetermined time (for example 2 seconds) after the release of vertical touch sensor or the first step must be repeated.” Col. 23:19-36.</p>



H. New Claim 36

`183 Patent Claim Language	`183 Patent Support
<p>36. The capacitive responsive electronic switching circuit as defined in claim 27 and further including an indicator for indicating when said detector circuit determines that the operator is proximal or touches said second touch terminal.</p>	<p>See Claim 32.</p> <p>The `183 Patent discloses “The microprocessor also allows the use of visual indicators such as LEDs or annunciators such as a bell or tone generator to confirm the actuation of a given touch switch or switches. This is particularly useful in cases where a sequence of actuations is required before an action occurs. The feedback to the operator provided by a visual or audio indicator activated by the microprocessor in response to intermediate touches in a required sequence can minimize time lost and/or frustration on the part of the operator due to failed actuations from partial touches or wrong actuations from touching the wrong pad in a given required sequence or combination of touches.” Col. 6:31-42.</p> <p>The `183 Patent discloses “A further option is to provide one or more LEDs 2205 or audible annunciators for visual or audible feedback to the operator. Specifically, in FIG. 19 the LED 2205 will come on when button 2201 has been successfully activated to cue the operator that it is time to move to button 2202. Where required a second LED with a different color than the first (yellow for the first LED and red for the second) can be provided to provide visual confirmation that the second button 2202 has been activated or that the required combination of the two buttons has been activated. Two different audible tone or sound generators could also be used in lieu of the LEDs to provide feedback to the operator.” Col. 23:1-12.</p> <p>The `183 Patent discloses “A red LED 2305 on top of the device shows the completion of the two step tum-on and activation of output relay 2310.” Col. 23:28-30.</p>

**I. New Claim 37**

For ease of analysis, new independent claim 37 is shown below with pseudo-amendments illustrating the differences between new claim 37 and original claim 27 of the '183 Patent.

'183 Patent Claim Language	'183 Patent Support
37. A capacitive responsive electronic switching circuit for a controlled device comprising:	See Claim 27.
<p>an oscillator providing a periodic output signal having a predefined frequency, <u>wherein an oscillator voltage is greater than a supply voltage;</u></p>	<p>See Figures 4, 5; and Claim 27.</p> <p>The '183 Patent discloses "Having provided a basis for the use of higher frequencies the basic construction of the electronic switching circuit constructed in accordance with a first embodiment of the present invention is now described with reference to FIG. 4. The electronic switching circuit includes a voltage regulator 100 including input lines 101 and 102 for receiving a 24 V AC line voltage and a line 103 for grounding the circuit. Voltage regulator 100 converts the received AC voltage to a DC voltage and supplies a regulated 5 V DC power to an oscillator 200 via lines 104 and 105. Voltage regulator also supplies oscillator 200 with 26 V DC power via line 106. The details of voltage regulator 100 are discussed below with reference to FIG. 5." Col. 11:60-Col. 12:5.</p> <p>The '183 Patent discloses "A preferred circuit for implementing a voltage regulator 100 is shown in FIG. 5. Voltage regulator 100 preferably includes an AC/DC convertor 110 for generating 29 V to 36 V unregulated DC on line 119. This unregulated DC power is supplied to a 5 V DC regulator 120 and to a 26 V DC regulator 130. AC/DC convertor 110 includes diodes 112, 114, 116, and 118, which rectify the supplied 24 V AC power provided on power lines 101 and 102." Col. 12:50-57; see also Col. 12:58-Col. 13:31.</p> <p>The '183 Patent discloses "The oscillator</p>