



US005087825A

United States Patent [19]

[11] Patent Number: **5,087,825**

Ingraham

[45] Date of Patent: **Feb. 11, 1992**

[54] **CAPACITY RESPONSIVE KEYBOARD**

[75] Inventor: **Ronald D. Ingraham, Quincy, Mich.**

[73] Assignee: **Nartron Corporation, Reed City, Mich.**

[21] Appl. No.: **480,293**

[22] Filed: **Feb. 15, 1990**

[51] Int. Cl.⁵ **H01H 47/00; H01H 35/00**

[52] U.S. Cl. **307/132 EA; 307/116; 307/132 R; 200/511; 361/280**

[58] Field of Search **307/116, 125, 132 R, 307/132 E, 132 EA, 132 M, 139; 200/5 A, 511, 512, 600, DIG. 1; 361/280; 178/18; 341/22, 33**

[56] **References Cited**

U.S. PATENT DOCUMENTS

2,783,308	2/1957	Rug	379/167
3,040,178	6/1962	Lyman et al.	250/213 A
3,200,304	8/1965	Atkins et al.	361/179
3,200,305	8/1965	Atkins et al.	361/179
3,200,306	8/1965	Atkins et al.	361/179
3,254,313	5/1966	Atkins et al.	331/111
3,275,897	9/1966	Atkins et al.	361/181
3,549,909	12/1970	Adelson	307/631
3,641,410	2/1972	Vogelsberg	388/830
3,651,391	3/1972	Vogelsberg	318/466
3,666,988	5/1972	Bellis	315/208
3,798,370	3/1974	Hurst	178/18
3,846,791	11/1974	Foster	341/33
3,899,713	8/1975	Barkan et al.	315/34
3,911,215	10/1975	Hurst et al.	178/18
3,965,465	6/1976	Alexander	340/527
3,984,757	10/1976	Gott et al.	323/326
4,016,453	4/1977	Moening	315/312
4,031,408	6/1977	Holz	307/116
4,056,699	11/1977	Jordan	200/5 A
4,071,689	1/1978	Talmage et al.	178/18
4,090,092	5/1978	Serrano	307/116
4,101,805	7/1978	Stone	315/74
4,101,886	7/1978	Grimes et al.	165/14
4,119,864	10/1978	Petrizio	307/116
4,123,631	10/1978	Lewis	200/600
4,136,291	1/1979	Waldron	307/308
4,145,748	3/1979	Eichelberger et al.	307/125
4,152,629	5/1979	Raupp	315/362
4,159,473	6/1979	Senk	340/565
4,161,766	7/1979	Castleberry et al.	361/280

4,174,517	11/1979	Mandel	340/310 A
4,210,822	7/1980	Wern	307/116
4,211,959	7/1980	Deavenport	315/362
4,213,061	7/1980	Conner	307/116
4,220,815	9/1980	Gibson et al.	178/18
4,223,301	9/1980	Grimes et al.	340/500
4,237,386	12/1980	Instance	307/116
4,237,421	12/1980	Waldron	307/116
4,246,533	1/1981	Chiang	323/349
4,257,117	3/1981	Besson	307/116
4,264,831	4/1981	Wern	307/638
4,289,972	9/1981	Wern	307/116
4,289,980	9/1981	McLaughlin	307/308
4,290,052	9/1981	Eichelberger et al.	341/33
4,293,987	10/1981	Gottbrecht	29/25.42
4,304,976	12/1981	Gottbrecht	219/10.55 B
4,308,443	12/1981	Tucker et al.	219/10.493
4,323,829	4/1982	Whitney et al.	318/55
4,360,737	11/1982	Leopold	307/116
4,374,381	2/1983	Ng et al.	340/711
4,380,040	4/1983	Posset	361/278
4,394,643	7/1983	Williams	341/33
4,400,758	8/1983	Frame	361/288

(List continued on next page.)

Assistant Examiner—Jeffrey A. Gaffin

Attorney, Agent, or Firm—Price, Heneveld, Cooper, DeWitt & Litton

[57] **ABSTRACT**

A capacity responsive keyboard which eliminates the necessity for metal films on the touch surface includes an insulated substrate having a plurality of electrically conductive plate members mounted thereon and a dielectric member positioned over the plate members. A piece of compressible, electrically-conductive foam is compressed between each plate member and the dielectric member to eliminate air from the electrical path between the dielectric member and the plate members. A grid of conductor segments separates the plate members defining a guard band to reduce interference between the switches. The guard band is connected with one power supply line of a switching circuit which produces outputs in response to capacity changes caused by a user touching the dielectric member.

18 Claims, 2 Drawing Sheets

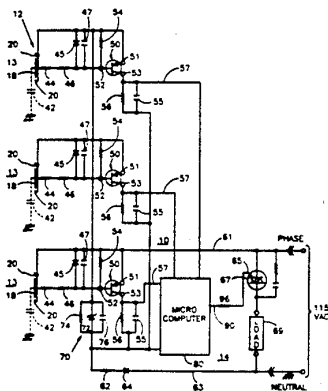

U.S. PATENT DOCUMENTS

4,413,252	11/1983	Tyler et al.	341/33	4,731,548	3/1988	Ingraham	307/116
4,439,647	3/1984	Calandrello et al.	200/5 A	4,731,694	3/1988	Grabner et al.	361/280
4,476,463	10/1984	Ng et al.	340/712	4,736,190	4/1988	Fiorella	200/517
4,493,377	1/1985	Günther et al.	173/170	4,740,781	4/1988	Brown	340/712
4,495,485	1/1985	Smith	341/33	4,743,895	5/1988	Alexander	340/712
4,529,968	7/1985	Hilsum et al.	340/635	4,758,735	7/1988	Ingraham	307/116
4,535,254	8/1985	Khatri	307/38	4,831,279	5/1989	Ingraham	307/116
4,550,310	10/1985	Yamaguchi et al.	341/33	4,855,550	8/1989	Schultz, Jr.	200/600
4,561,002	12/1985	Chui	341/26	4,894,493	1/1990	Smith et al.	200/5 A
4,567,470	1/1986	Yoshikawa et al.	341/33	4,901,074	2/1990	Sinn et al.	341/22
4,584,519	4/1986	Gruodis	323/245	4,920,343	4/1990	Schwartz	341/33
4,614,937	9/9186	Poujois	341/33	4,924,222	5/1990	Antikidis et al.	200/600
4,651,133	3/1987	Ganesan et al.	341/26	5,012,124	4/1991	Holloway	307/116

Primary Examiner—A. D. Pellinen

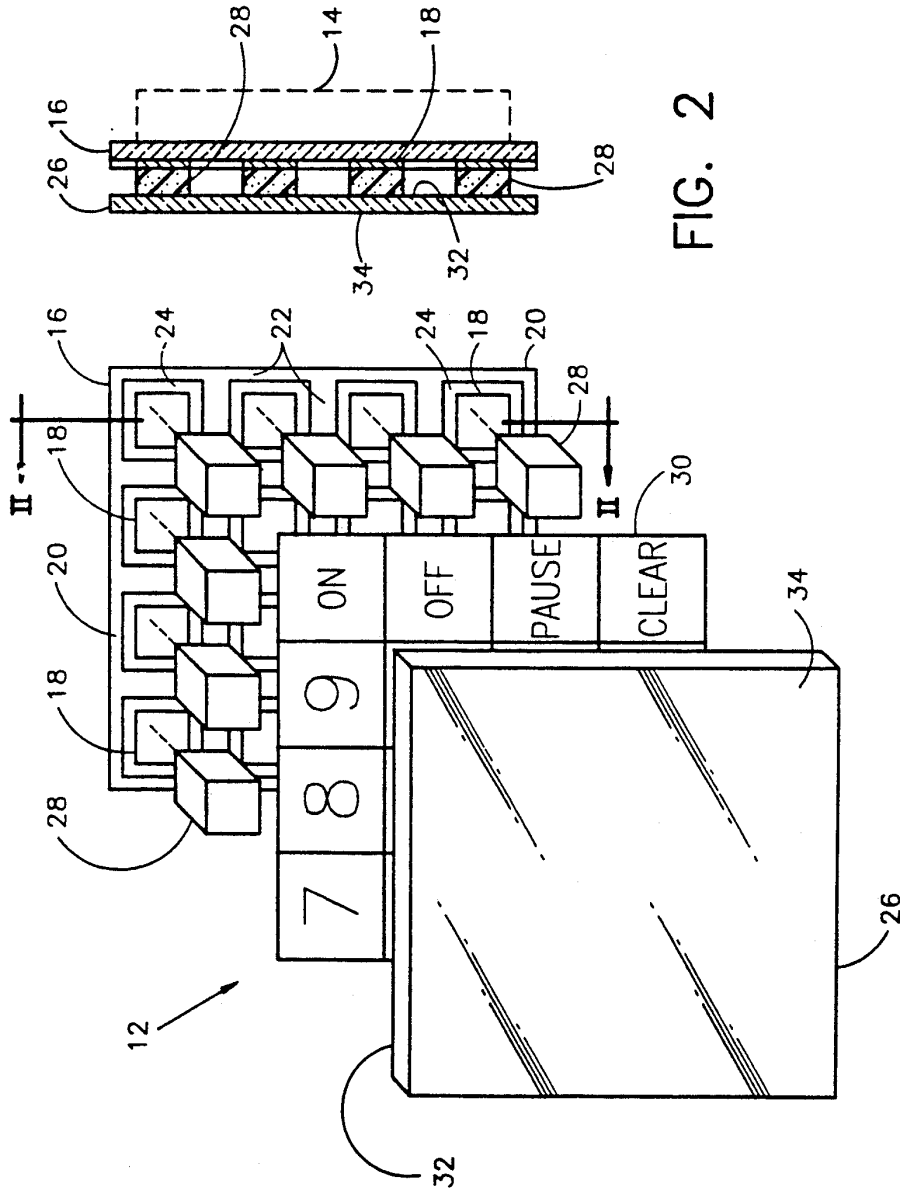

FIG. 2

FIG. 1

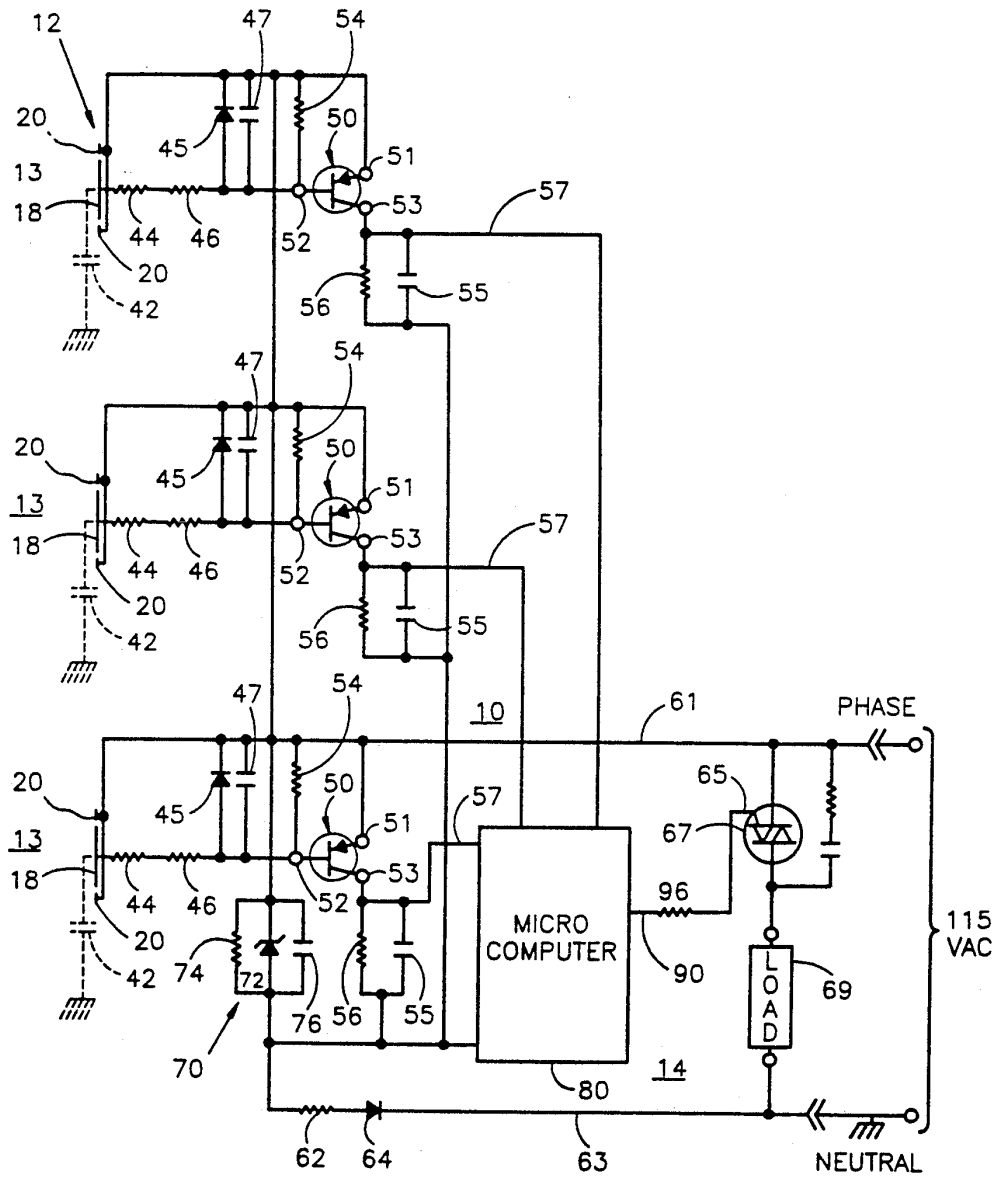

FIG. 3

CAPACITY RESPONSIVE KEYBOARD

BACKGROUND OF THE INVENTION

This invention relates to switches that respond to the change in capacity from a user touching a surface portion of the switch. The invention is especially adapted for a keyboard made up of a plurality of such capacity responsive switches.

Touch-responsive switches in the form of "capacitive glass" are common in the appliance field. This special glass has conductive elements fired on each side in a manner that forms a pair of series-connected capacitors having input and output terminals on the glass surface facing away from the user. A common plate of the two capacitors is formed on the outer glass surface facing the user. A high frequency oscillator applies pulses to the capacitors. A switching circuit connected with the capacitors interprets the presence of pulses as a no-input condition. When a user touches the capacitor plate on the outer surface of the glass, the high frequency pulses are shunted to ground through the user. The switch circuit interprets the absence of pulses as a positive input condition and responds by actuating an output device. Such a switch system is illustrated in U.S. Pat. No. 4,308,443, issued to Tucker et al.

Such "capacitive-glass" switch systems are not truly capacity responsive but require physical contact by the user with the electrically-conductive common plate of the series capacitors. This requires a metal film, such as tin oxide, be deposited on the outer surface of the glass. Such metal film is subject to abrasion by repeated cleaning and may even abrade to the point of erratic operation. A further problem with such system is that a failure of the high frequency oscillator causes a no-pulse condition, to which the switching circuit may detrimentally respond by energizing one or more outputs.

In my U.S. Pat. Nos. 4,731,548 and 4,758,735 I disclose touch control switch circuits which respond to a change in the capacity-to-ground of a plate member as a result of contact by the body of a user. Such circuits do not require a metal film on the surface portion contacted by the user so the problem of metal film abrasion is avoided. Further, the circuits disclosed in my patents are not subject to the catastrophic failure of erroneous output switching caused by the failure of an oscillator.

SUMMARY OF THE INVENTION

The present invention is directed to a keyboard system incorporating a plurality of capacity responsive switches in a keyboard assembly that may be used with a control circuit that embodies the principles of my aforementioned patents. The present invention may be embodied in a capacity responsive keyboard system having a planar substrate with a plurality of electrically conductive plate members mounted thereto and insulated from each other. A substantially rigid planar dielectric member overlies the conductive members and has a surface facing the conductive members. A plurality of flexible electrically conductive transmission members extend between the dielectric member and individual conductive members. The transmission members are sized to provide airtight interfaces with the dielectric member and the associated plate member. Circuit means connected with the plate members respond to capacity between the plate members and ground for producing a

signal indicative of a change in capacity between plate members and ground.

Another problem overcome by the present invention is the tendency of capacity responsive switches that are closely positioned in a keyboard system to inadvertently become actuated even though the user is touching an adjacent switch. This problem is overcome by a keyboard system which embodies the present invention and in which an electrically conductive guard band is provided on the substrate between adjacent plate members. The guard band is connected with a reference voltage of the control circuit to isolate the capacity change caused by the user to only one switch. These and other objects, advantages and features of this invention will become apparent upon review of the following specification in conjunction with the drawings.

BRIEF DESCRIPTION OF THE DRAWINGS

FIG. 1 is an exploded perspective view of a capacitive responsive keyboard embodying the invention;

FIG. 2 is a side elevation of the keyboard in FIG. 1; and

FIG. 3 is a schematic diagram of a control circuit useful with the invention.

DESCRIPTION OF THE PREFERRED EMBODIMENT

Referring now specifically to the drawings, and the illustrative embodiments depicted therein, a capacity responsive keyboard system 10 includes a touch plate assembly 12 and a control circuit 14 connected with touch plate assembly 12 (FIG. 3). FIG. 3 illustrates a plurality of input portions 13 of touch plate assembly 12 and a control circuit 14 that actuates a single load 69 such as an electric motor. However, it should be understood that the keyboard system 10 may include a greater or lesser number of input portions 13 than illustrated, depending on the number and variety of modes in which load 69 may be controlled. Additionally, more than one load 69 may be controlled. Touch plate assembly 12 includes a substrate 16 on which a plurality of electrically conductive plate members 18 are mounted on one surface thereof. Substrate 16 is an insulator and plates 18 are spaced apart in order to insulate plates 18 from one another and from ground. Also positioned on substrate 16 is a guard band, generally shown at 20. Guard band 20 is a grid of conductor segments 22 extending between adjacent pairs of plate members 18. All conductor segments 22 are physically and electrically interconnected to define a plurality of spaces 24 with one plate member 18 positioned centrally within each space 24. Components of control circuit 14 may be positioned on the side of substrate 16 opposite plate members 18 and guard band 20 (FIG. 2).

A planar dielectric member 26 is spaced from substrate 16 facing plate members 18. Dielectric member 26 is made from a non-porous insulating material such as polycarbonate or glass. A plurality of flexible, electrically conductive transmission members 28 are sandwiched between a surface 32 of dielectric member 26 and substrate 16. Each transmission member 28 has a cross section approximately the size of plate members 18 and is positioned to overlie one of the plate members 18. An indicia layer 30 may be adhered to surface 32 of dielectric member 26 which faces substrate 16. The purpose of indicia layer 30 is to provide an indication of the function of each input portion 13.

Explore Litigation Insights

Docket Alarm provides insights to develop a more informed litigation strategy and the peace of mind of knowing you're on top of things.

Real-Time Litigation Alerts



Keep your litigation team up-to-date with **real-time alerts** and advanced team management tools built for the enterprise, all while greatly reducing PACER spend.

Our comprehensive service means we can handle Federal, State, and Administrative courts across the country.

Advanced Docket Research



With over 230 million records, Docket Alarm's cloud-native docket research platform finds what other services can't. Coverage includes Federal, State, plus PTAB, TTAB, ITC and NLRB decisions, all in one place.

Identify arguments that have been successful in the past with full text, pinpoint searching. Link to case law cited within any court document via Fastcase.

Analytics At Your Fingertips



Learn what happened the last time a particular judge, opposing counsel or company faced cases similar to yours.

Advanced out-of-the-box PTAB and TTAB analytics are always at your fingertips.

API

Docket Alarm offers a powerful API (application programming interface) to developers that want to integrate case filings into their apps.

LAW FIRMS

Build custom dashboards for your attorneys and clients with live data direct from the court.

Automate many repetitive legal tasks like conflict checks, document management, and marketing.

FINANCIAL INSTITUTIONS

Litigation and bankruptcy checks for companies and debtors.

E-DISCOVERY AND LEGAL VENDORS

Sync your system to PACER to automate legal marketing.