

Under the Paperwork Reduction Act of 1995, no persons are required to respond to a collection of information unless it displays a valid OMB control number.

CHANGE OF CORRESPONDENCE ADDRESS <i>Patent</i> Address to: Mail Stop Post Issue Commissioner for Patents P.O. Box 1450 Alexandria, VA 22313-1450	Patent Number	5,796,183
	Issue Date	August 18, 1998
	Application Number	08/601,268
	Filing Date	January 31, 1996
	First Named Inventor	Hourmand
	Attorney Docket Number	NAR0227L

Please change the Correspondence Address for the above-identified patent to:

The address associated with Customer Number: 25962

OR

Firm or Individual Name

Address

City	State	ZIP
Country		
Telephone	Email	

This form cannot be used to change the data associated with a Customer Number. To change the data associated with an existing Customer Number use "Request for Customer Number Data Change" (PTO/SB/124).

This form will not affect any "fee address" provided for the above-identified patent. To change a "fee address" use the "Fee Address Indication Form" (PTO/SB/47).

I am the:

Patentee.

Assignee of record of the entire interest. See 37 CFR 3.71. Statement under 37 CFR 3.73(b) is enclosed. (Form PTO/SB/96).

Attorney or agent of record. Registration Number: _____

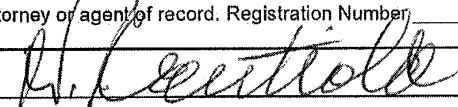
Signature 

Printed Name **Norman Rautiola, Manager, UUSI, LLC**

Date **9-20-12** Telephone **231-832-5525**

NOTE: Signatures of all the inventors or assignees of record of the entire interest or their representative(s) are required. Submit multiple forms if more than one signature is required, see below*.

*Total of _____ forms are submitted.

This collection of information is required by 37 CFR 1.33. The information is required to obtain or retain a benefit by the public which is to file (and by the USPTO to process) an application. Confidentiality is governed by 35 U.S.C. 122 and 37 CFR 1.11 and 1.14. This collection is estimated to take 3 minutes to complete, including gathering, preparing, and submitting the completed application form to the USPTO. Time will vary depending upon the individual case. Any comments on the amount of time you require to complete this form and/or suggestions for reducing this burden, should be sent to the Chief Information Officer, U.S. Patent and Trademark Office, U.S. Department of Commerce, P.O. Box 1450, Alexandria, VA 22313-1450. DO NOT SEND FEES OR COMPLETED FORMS TO THIS ADDRESS. SEND TO: Mail Stop Post Issue, Commissioner for Patents, P.O. Box 1450, Alexandria, VA 22313-1450.

If you need assistance in completing the form, call 1-800-PTO-9199 and select option 2.

Under the Paperwork Reduction Act of 1995, no persons are required to respond to a collection of information unless it displays a valid OMB control number.

STATEMENT UNDER 37 CFR 3.73(b)

Applicant/Patent Owner: Hourmand

Application No./Patent No.: 5,796,183 Filed/Issue Date: August 18, 1998

Titled: **Capacitive Responsive Electronic Switching Circuit**

UUSI, LLC, a Corporation
(Name of Assignee) (Type of Assignee, e.g., corporation, partnership, university, government agency, etc.)

states that it is:

1. the assignee of the entire right, title, and interest in;
2. an assignee of less than the entire right, title and interest in
(The extent (by percentage) of its ownership interest is _____ %); or
3. the assignee of an undivided interest in the entirety of (a complete assignment from one of the joint inventors was made)

the patent application/patent identified above, by virtue of either:

- A. An assignment from the inventor(s) of the patent application/patent identified above. The assignment was recorded in the United States Patent and Trademark Office at Reel _____, Frame _____, or for which a copy thereof is attached.

OR

- B. A chain of title from the inventor(s), of the patent application/patent identified above, to the current assignee as follows:

1. From: Byron Hourmand To: Nartron Corporation

The document was recorded in the United States Patent and Trademark Office at
Reel 008254, Frame 0496, or for which a copy thereof is attached.

2. From: Byron Hourmand To: Nartron Corporation

The document was recorded in the United States Patent and Trademark Office at
Reel 008443, Frame 0749, or for which a copy thereof is attached.

3. From: John M. Washeleski To: Nartron Corporation

The document was recorded in the United States Patent and Trademark Office at
Reel 028804, Frame 0075, or for which a copy thereof is attached.

Additional documents in the chain of title are listed on a supplemental sheet(s).

As required by 37 CFR 3.73(b)(1)(i), the documentary evidence of the chain of title from the original owner to the assignee was, or concurrently is being, submitted for recordation pursuant to 37 CFR 3.11.

[NOTE: A separate copy (i.e., a true copy of the original assignment document(s)) must be submitted to Assignment Division in accordance with 37 CFR Part 3, to record the assignment in the records of the USPTO. See MPEP 302.08]

The undersigned (whose title is supplied below) is authorized to act on behalf of the assignee.

Signature

9-20-12
Date

Norman Rautiola
Printed or Typed Name

Manager
Title

This collection of information is required by 37 CFR 3.73(b). The information is required to obtain or retain a benefit by the public which is to file (and by the USPTO to process) an application. Confidentiality is governed by 35 U.S.C. 122 and 37 CFR 1.11 and 1.14. This collection is estimated to take 12 minutes to complete, including gathering, preparing, and submitting the completed application form to the USPTO. Time will vary depending upon the individual case. Any comments on the amount of time you require to complete this form and/or suggestions for reducing this burden, should be sent to the Chief Information Officer, U.S. Patent and Trademark Office, U.S. Department of Commerce, P.O. Box 1450, Alexandria, VA 22313-1450. DO NOT SEND FEES OR COMPLETED FORMS TO THIS ADDRESS. SEND TO: Commissioner for Patents, P.O. Box 1460, Alexandria, VA 22313-1460.

If you need assistance in completing the form, call 1-800-PTO-9199 and select option 2.

Additional documents in the chain:

4. From: Stephen R.W. Cooper To: Nartron Corporation

The document was recorded in the United States Patent and Trademark Office at
Reel 028804, Frame 0137, or for which a copy thereof is attached.

5. From: Nartron Corporation To: : UUSI, LLC

The document was recorded in the United States Patent and Trademark Office at
Reel 023679, Frame 0803, or for which a copy thereof is attached.

Electronic Acknowledgement Receipt

EFS ID:	13811346
Application Number:	08601268
International Application Number:	
Confirmation Number:	3176
Title of Invention:	CAPACITIVE RESPONSIVE ELECTRONIC SWITCHING CIRCUIT
First Named Inventor/Applicant Name:	BYRON HOURMAND
Customer Number:	22045
Filer:	Brian A. Carlson/Michelle Hatcher
Filer Authorized By:	Brian A. Carlson
Attorney Docket Number:	NAR0227L
Receipt Date:	21-SEP-2012
Filing Date:	31-JAN-1996
Time Stamp:	17:38:40
Application Type:	Utility under 35 USC 111(a)

Payment information:

Submitted with Payment	no
------------------------	----

File Listing:

Document Number	Document Description	File Name	File Size(Bytes)/ Message Digest	Multi Part /.zip	Pages (if appl.)
1	Change of Address	NAR0227L_ChangeOfAddress.pdf	92526 <small>2fe49faf534dc46b30e11d3441674a667445bfc2</small>	no	1

Warnings:

Information:

2	Assignee showing of ownership per 37 CFR 3.73(b).	NAR0227L_StatementUnder_3_73.pdf	103983 cee065b7cf28db3a1b11fd9c13ca8377085e1a60	no	2
Warnings:					
Information:					
Total Files Size (in bytes):			196509		
<p>This Acknowledgement Receipt evidences receipt on the noted date by the USPTO of the indicated documents, characterized by the applicant, and including page counts, where applicable. It serves as evidence of receipt similar to a Post Card, as described in MPEP 503.</p> <p><u>New Applications Under 35 U.S.C. 111</u> If a new application is being filed and the application includes the necessary components for a filing date (see 37 CFR 1.53(b)-(d) and MPEP 506), a Filing Receipt (37 CFR 1.54) will be issued in due course and the date shown on this Acknowledgement Receipt will establish the filing date of the application.</p> <p><u>National Stage of an International Application under 35 U.S.C. 371</u> If a timely submission to enter the national stage of an international application is compliant with the conditions of 35 U.S.C. 371 and other applicable requirements a Form PCT/DO/EO/903 indicating acceptance of the application as a national stage submission under 35 U.S.C. 371 will be issued in addition to the Filing Receipt, in due course.</p> <p><u>New International Application Filed with the USPTO as a Receiving Office</u> If a new international application is being filed and the international application includes the necessary components for an international filing date (see PCT Article 11 and MPEP 1810), a Notification of the International Application Number and of the International Filing Date (Form PCT/RO/105) will be issued in due course, subject to prescriptions concerning national security, and the date shown on this Acknowledgement Receipt will establish the international filing date of the application.</p>					

UNITED STATES PATENT AND TRADEMARK OFFICE
CERTIFICATE OF CORRECTION

PATENT NO. : 5,796,183
APPLICATION NO. : 08/601268
DATED : August 18, 1998
INVENTOR(S) : Byron Hourmand et al.

Page 1 of 1

It is certified that error appears in the above-identified patent and that said Letters Patent is hereby corrected as shown below:

Title Page, Item (75) Inventor, should read --(75) Inventors: Byron Hourmand,
Hersey, MI (US); John M. Washeleski, Cadillac, MI (US); Stephen R. W. Cooper,
Fowlerville, MI (US)--.

Signed and Sealed this
Eleventh Day of October, 2011

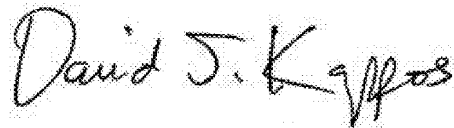

David J. Kappos
Director of the United States Patent and Trademark Office



UNITED STATES PATENT AND TRADEMARK OFFICE

UNITED STATES DEPARTMENT OF COMMERCE
United States Patent and Trademark Office
Address: COMMISSIONER FOR PATENTS
P.O. Box 1450
Alexandria, Virginia 22313-1450
www.uspto.gov

Table with 7 columns: APPLICATION NUMBER, FILING or 371(c) DATE, GRP ART UNIT, FIL FEE REC'D, ATTY DOCKET NO, TOT CLAIMS, IND CLAIMS. Row 1: 08/601,268, 01/31/1996, 2836, 771, NAR0227L, 20, 4

CONFIRMATION NO. 3176

CORRECTED FILING RECEIPT



22045
BROOKS KUSHMAN P.C.
1000 TOWN CENTER
TWENTY-SECOND FLOOR
SOUTHFIELD, MI 48075

Date Mailed: 08/25/2011

Receipt is acknowledged of this non-provisional patent application. The application will be taken up for examination in due course. Applicant will be notified as to the results of the examination. Any correspondence concerning the application must include the following identification information: the U.S. APPLICATION NUMBER, FILING DATE, NAME OF APPLICANT, and TITLE OF INVENTION. Fees transmitted by check or draft are subject to collection. Please verify the accuracy of the data presented on this receipt. If an error is noted on this Filing Receipt, please submit a written request for a Filing Receipt Correction. Please provide a copy of this Filing Receipt with the changes noted thereon. If you received a "Notice to File Missing Parts" for this application, please submit any corrections to this Filing Receipt with your reply to the Notice. When the USPTO processes the reply to the Notice, the USPTO will generate another Filing Receipt incorporating the requested corrections

Applicant(s)

BYRON HOURMAND, HERSEY, MI;
JOHN M. WASHELESKI, Cadillac, MI;
STEPHEN R. W. COOPER, Fowlerville, MI;

Power of Attorney: The patent practitioners associated with Customer Number 22045

Domestic Priority data as claimed by applicant

Foreign Applications (You may be eligible to benefit from the Patent Prosecution Highway program at the USPTO. Please see http://www.uspto.gov for more information.)

If Required, Foreign Filing License Granted: 07/24/1996

The country code and number of your priority application, to be used for filing abroad under the Paris Convention, is US 08/601,268

Projected Publication Date: None, application is not eligible for pre-grant publication

Non-Publication Request: No

Early Publication Request: No

** SMALL ENTITY **

Title

CAPACITIVE RESPONSIVE ELECTRONIC SWITCHING CIRCUIT

Preliminary Class

307

PROTECTING YOUR INVENTION OUTSIDE THE UNITED STATES

Since the rights granted by a U.S. patent extend only throughout the territory of the United States and have no effect in a foreign country, an inventor who wishes patent protection in another country must apply for a patent in a specific country or in regional patent offices. Applicants may wish to consider the filing of an international application under the Patent Cooperation Treaty (PCT). An international (PCT) application generally has the same effect as a regular national patent application in each PCT-member country. The PCT process **simplifies** the filing of patent applications on the same invention in member countries, but **does not result** in a grant of "an international patent" and does not eliminate the need of applicants to file additional documents and fees in countries where patent protection is desired.

Almost every country has its own patent law, and a person desiring a patent in a particular country must make an application for patent in that country in accordance with its particular laws. Since the laws of many countries differ in various respects from the patent law of the United States, applicants are advised to seek guidance from specific foreign countries to ensure that patent rights are not lost prematurely.

Applicants also are advised that in the case of inventions made in the United States, the Director of the USPTO must issue a license before applicants can apply for a patent in a foreign country. The filing of a U.S. patent application serves as a request for a foreign filing license. The application's filing receipt contains further information and guidance as to the status of applicant's license for foreign filing.

Applicants may wish to consult the USPTO booklet, "General Information Concerning Patents" (specifically, the section entitled "Treaties and Foreign Patents") for more information on timeframes and deadlines for filing foreign patent applications. The guide is available either by contacting the USPTO Contact Center at 800-786-9199, or it can be viewed on the USPTO website at <http://www.uspto.gov/web/offices/pac/doc/general/index.html>.

For information on preventing theft of your intellectual property (patents, trademarks and copyrights), you may wish to consult the U.S. Government website, <http://www.stopfakes.gov>. Part of a Department of Commerce initiative, this website includes self-help "toolkits" giving innovators guidance on how to protect intellectual property in specific countries such as China, Korea and Mexico. For questions regarding patent enforcement issues, applicants may call the U.S. Government hotline at 1-866-999-HALT (1-866-999-4158).

LICENSE FOR FOREIGN FILING UNDER

Title 35, United States Code, Section 184

Title 37, Code of Federal Regulations, 5.11 & 5.15

GRANTED

The applicant has been granted a license under 35 U.S.C. 184, if the phrase "IF REQUIRED, FOREIGN FILING LICENSE GRANTED" followed by a date appears on this form. Such licenses are issued in all applications where the conditions for issuance of a license have been met, regardless of whether or not a license may be required as

set forth in 37 CFR 5.15. The scope and limitations of this license are set forth in 37 CFR 5.15(a) unless an earlier license has been issued under 37 CFR 5.15(b). The license is subject to revocation upon written notification. The date indicated is the effective date of the license, unless an earlier license of similar scope has been granted under 37 CFR 5.13 or 5.14.

This license is to be retained by the licensee and may be used at any time on or after the effective date thereof unless it is revoked. This license is automatically transferred to any related applications(s) filed under 37 CFR 1.53(d). This license is not retroactive.

The grant of a license does not in any way lessen the responsibility of a licensee for the security of the subject matter as imposed by any Government contract or the provisions of existing laws relating to espionage and the national security or the export of technical data. Licensees should apprise themselves of current regulations especially with respect to certain countries, of other agencies, particularly the Office of Defense Trade Controls, Department of State (with respect to Arms, Munitions and Implements of War (22 CFR 121-128)); the Bureau of Industry and Security, Department of Commerce (15 CFR parts 730-774); the Office of Foreign Assets Control, Department of Treasury (31 CFR Parts 500+) and the Department of Energy.

NOT GRANTED

No license under 35 U.S.C. 184 has been granted at this time, if the phrase "IF REQUIRED, FOREIGN FILING LICENSE GRANTED" DOES NOT appear on this form. Applicant may still petition for a license under 37 CFR 5.12, if a license is desired before the expiration of 6 months from the filing date of the application. If 6 months has lapsed from the filing date of this application and the licensee has not received any indication of a secrecy order under 35 U.S.C. 181, the licensee may foreign file the application pursuant to 37 CFR 5.15(b).



UNITED STATES PATENT AND TRADEMARK OFFICE

Commissioner for Patents
United States Patent and Trademark Office
P.O. Box 1450
Alexandria, VA 22313-1450
www.uspto.gov

**BROOKS KUSHMAN P.C.
1000 TOWN CENTER
TWENTY-SECOND FLOOR
SOUTHFIELD, MI 48075**

**MAILED
AUG 25 2011
OFFICE OF PETITIONS**

In re Patent No. 5,796,183 :
Issue Date: August 18, 1998 :
Application No. 08/601,268 : **ON PETITION**
Filed: January 31, 1996 :
Attorney Docket No. :

This is a decision on the petition filed August 19, 2011 under 37 CFR 1.323, which is being treated as a request under 37 CFR 1.324 to correct the name of the inventors by way of a Certificate of Correction.

The petition is **GRANTED**.

Petitioner request that the inventorship of this application be amended by the addition of **JOHN M. WASHELESKI** of Cadillac, Michigan, and **STEPHEN R. W. COOPER**, of Fowlerville, Michigan, based on the Consent Judgment dated September 8 2010 under 35 USC 256. Petitioner includes with the renewed petition an Oath having the above inventors.

The inventorship of this patent has been amended by the addition of **JOHN M. WASHELESKI** and **STEPHEN R. W. COOPER**.

Telephone inquiries concerning this decision may be directed to the undersigned at (571) 272-0602. Inquiries regarding the issuance of a certificate of correction should be directed to the Certificate of Correction Branch at (571) 272-4200.

Thurman K. Page
Petitions Examiner
Office of Petitions

Enclosure: Corrected filing receipt



UNITED STATES PATENT AND TRADEMARK OFFICE

UNITED STATES DEPARTMENT OF COMMERCE
United States Patent and Trademark Office
Address: COMMISSIONER FOR PATENTS
P.O. Box 1450
Alexandria, Virginia 22313-1450
www.uspto.gov

APPLICATION NUMBER	FILING or 371(c) DATE	GRP ART UNIT	FIL FEE REC'D	ATTY. DOCKET NO	TOT CLAIMS	IND CLAIMS
08/601,268	01/31/1996	2836	771	NAR0227L	20	4

CONFIRMATION NO. 3176

CORRECTED FILING RECEIPT



22045
BROOKS KUSHMAN P.C.
1000 TOWN CENTER
TWENTY-SECOND FLOOR
SOUTHFIELD, MI 48075

Date Mailed: 08/25/2011

Receipt is acknowledged of this non-provisional patent application. The application will be taken up for examination in due course. Applicant will be notified as to the results of the examination. Any correspondence concerning the application must include the following identification information: the U.S. APPLICATION NUMBER, FILING DATE, NAME OF APPLICANT, and TITLE OF INVENTION. Fees transmitted by check or draft are subject to collection. Please verify the accuracy of the data presented on this receipt. **If an error is noted on this Filing Receipt, please submit a written request for a Filing Receipt Correction. Please provide a copy of this Filing Receipt with the changes noted thereon. If you received a "Notice to File Missing Parts" for this application, please submit any corrections to this Filing Receipt with your reply to the Notice. When the USPTO processes the reply to the Notice, the USPTO will generate another Filing Receipt incorporating the requested corrections**

Applicant(s)

BYRON HOURMAND, HERSEY, MI;
JOHN M. WASHELESKI, Cadillac, MI;
STEPHEN R. W. COOPER, Fowlerville, MI;

Power of Attorney: The patent practitioners associated with Customer Number 22045

Domestic Priority data as claimed by applicant

Foreign Applications (You may be eligible to benefit from the **Patent Prosecution Highway** program at the USPTO. Please see <http://www.uspto.gov> for more information.)

If Required, Foreign Filing License Granted: 07/24/1996

The country code and number of your priority application, to be used for filing abroad under the Paris Convention, is **US 08/601,268**

Projected Publication Date: None, application is not eligible for pre-grant publication

Non-Publication Request: No

Early Publication Request: No

**** SMALL ENTITY ****

Title

CAPACITIVE RESPONSIVE ELECTRONIC SWITCHING CIRCUIT

Preliminary Class

307

PROTECTING YOUR INVENTION OUTSIDE THE UNITED STATES

Since the rights granted by a U.S. patent extend only throughout the territory of the United States and have no effect in a foreign country, an inventor who wishes patent protection in another country must apply for a patent in a specific country or in regional patent offices. Applicants may wish to consider the filing of an international application under the Patent Cooperation Treaty (PCT). An international (PCT) application generally has the same effect as a regular national patent application in each PCT-member country. The PCT process **simplifies** the filing of patent applications on the same invention in member countries, but **does not result** in a grant of "an international patent" and does not eliminate the need of applicants to file additional documents and fees in countries where patent protection is desired.

Almost every country has its own patent law, and a person desiring a patent in a particular country must make an application for patent in that country in accordance with its particular laws. Since the laws of many countries differ in various respects from the patent law of the United States, applicants are advised to seek guidance from specific foreign countries to ensure that patent rights are not lost prematurely.

Applicants also are advised that in the case of inventions made in the United States, the Director of the USPTO must issue a license before applicants can apply for a patent in a foreign country. The filing of a U.S. patent application serves as a request for a foreign filing license. The application's filing receipt contains further information and guidance as to the status of applicant's license for foreign filing.

Applicants may wish to consult the USPTO booklet, "General Information Concerning Patents" (specifically, the section entitled "Treaties and Foreign Patents") for more information on timeframes and deadlines for filing foreign patent applications. The guide is available either by contacting the USPTO Contact Center at 800-786-9199, or it can be viewed on the USPTO website at <http://www.uspto.gov/web/offices/pac/doc/general/index.html>.

For information on preventing theft of your intellectual property (patents, trademarks and copyrights), you may wish to consult the U.S. Government website, <http://www.stopfakes.gov>. Part of a Department of Commerce initiative, this website includes self-help "toolkits" giving innovators guidance on how to protect intellectual property in specific countries such as China, Korea and Mexico. For questions regarding patent enforcement issues, applicants may call the U.S. Government hotline at 1-866-999-HALT (1-866-999-4158).

LICENSE FOR FOREIGN FILING UNDER

Title 35, United States Code, Section 184

Title 37, Code of Federal Regulations, 5.11 & 5.15

GRANTED

The applicant has been granted a license under 35 U.S.C. 184, if the phrase "IF REQUIRED, FOREIGN FILING LICENSE GRANTED" followed by a date appears on this form. Such licenses are issued in all applications where the conditions for issuance of a license have been met, regardless of whether or not a license may be required as

set forth in 37 CFR 5.15. The scope and limitations of this license are set forth in 37 CFR 5.15(a) unless an earlier license has been issued under 37 CFR 5.15(b). The license is subject to revocation upon written notification. The date indicated is the effective date of the license, unless an earlier license of similar scope has been granted under 37 CFR 5.13 or 5.14.

This license is to be retained by the licensee and may be used at any time on or after the effective date thereof unless it is revoked. This license is automatically transferred to any related applications(s) filed under 37 CFR 1.53(d). This license is not retroactive.

The grant of a license does not in any way lessen the responsibility of a licensee for the security of the subject matter as imposed by any Government contract or the provisions of existing laws relating to espionage and the national security or the export of technical data. Licensees should apprise themselves of current regulations especially with respect to certain countries, of other agencies, particularly the Office of Defense Trade Controls, Department of State (with respect to Arms, Munitions and Implements of War (22 CFR 121-128)); the Bureau of Industry and Security, Department of Commerce (15 CFR parts 730-774); the Office of Foreign Assets Control, Department of Treasury (31 CFR Parts 500+) and the Department of Energy.

NOT GRANTED

No license under 35 U.S.C. 184 has been granted at this time, if the phrase "IF REQUIRED, FOREIGN FILING LICENSE GRANTED" DOES NOT appear on this form. Applicant may still petition for a license under 37 CFR 5.12, if a license is desired before the expiration of 6 months from the filing date of the application. If 6 months has lapsed from the filing date of this application and the licensee has not received any indication of a secrecy order under 35 U.S.C. 181, the licensee may foreign file the application pursuant to 37 CFR 5.15(b).

IN THE UNITED STATES PATENT AND TRADEMARK OFFICE

In re patent of:

BRYON HOURMAND, et al.

U.S. Patent No.: 5,796,183

Issue Date: August 18, 1998

For: CAPACITIVE RESPONSIVE ELECTRONIC SWITCHING CIRCUIT

Attorney Docket No.: NAR 0227 L

RENEWED REQUEST FOR "CERTIFICATE OF CORRECTION"

Attention Certificate of Correction Branch
Commissioner for Patents
U.S. Patent & Trademark Office
P.O. Box 1450
Alexandria, VA 22313-1450

Sir:

It is requested that a Certificate of Correction be issued for the above-identified patent under the provisions of 37 C.F.R. § 1.323. The corrections noted are as follows:

The inventorship of this patent is amended to add the following joint inventors:

John M. Washeleski, of Cadillac, Michigan; and

Stephen R. W. Cooper, of Fowlerville, Michigan

Enclosed herewith is a copy of the form for Certificate of Correction (PTO/SB/44) together with a copy of the court order correcting inventorship from the United States District

Court, Western District of Michigan, as well as a Declaration, Statement of Patent Owner and Declaration of Robert C.J. Tuttle. The amount of \$100 pursuant to 37 C.F.R. § 1.20(a) has been paid by electronic submission herewith. The Commissioner is hereby authorized to charge any additional fees to our Deposit Account No. 02-3978.

Please contact the undersigned should you have any questions.

Respectfully submitted,

BRYON HOURMAND, et al.

By /John E. Nemazi/

John E. Nemazi

Reg. No. 30,876

Attorney/Agent for Applicant

Date: August 19, 2011

BROOKS KUSHMAN P.C.
1000 Town Center, 22nd Floor
Southfield, MI 48075-1238
Phone: (248) 358-4400
Fax: (248) 358-3351

UNITED STATES PATENT AND TRADEMARK OFFICE
CERTIFICATE OF CORRECTION

PATENT NO. : 5,796,183
APPLICATION NO. : 601,268
ISSUE DATE : August 18, 1998
INVENTOR(S) : Byron Hourmand et al

Page 1 of 1

It is certified that an error appears or errors appear in the above-identified patent and that said Letters Patent is hereby corrected as shown below:

The inventorship of this patent is amended to add the following joint inventors:

John M. Washeleski, of Cadillac, Michigan, and

Stephen R. W. Cooper, of Fowlerville, Michigan.

MAILING ADDRESS OF SENDER:

BROOKS KUSHMAN P.C.
1000 Town Center, 22nd Floor
Southfield, Michigan 48075-1238

This collection of information is required by 37 CFR 1.322, 1.323, and 1.324. The information is required to obtain or retain a benefit by the public which is to file (and by the USPTO to process) an application. Confidentiality is governed by 35 U.S.C. 122 and 37 CFR 1.14. This collection is estimated to take 1.0 hour to complete, including gathering, preparing, and submitting the completed application form to the USPTO. Time will vary depending upon the individual case. Any comments on the amount of time you require to complete this form and/or suggestions for reducing this burden, should be sent to the Chief Information Officer, U.S. Patent & Trademark Office, U.S. Department of Commerce, P.O. Box 1450, Alexandria, VA 22313-1450. DO NOT SEND FEES OR COMPLETED FORMS TO THIS ADDRESS. SEND TO: Attention Certificate of Corrections Branch, Commissioner for Patents, P.O. Box 1450, Alexandria, VA 22313-1450.

DECLARATION FOR PATENT APPLICATION AND POWER OF ATTORNEY

Atty. Docket No. NAR 0227 L
 First Named Inventor Byron Hourmand

I hereby declare that:

Each inventor's residence, mailing address, and citizenship are as stated below next to their name.

I believe the inventor(s) named below to be the original and first inventor(s) of the subject matter which is claimed and for which a patent is sought on the invention entitled:

CAPACITIVE RESPONSIVE ELECTRONIC SWITCHING CIRCUIT,

the specification of which:

- is attached hereto; or
- was filed on (MM/DD/YYYY) January 31, 1996 as U.S. Application Number or PCT International Application Number 601,268, and issued on (MM/DD/YYYY) 08/18/1998 as U.S. Patent 5,796,183.

I hereby state that I have reviewed and understand the contents of the above-identified specification, including the claims, as amended by any amendment specifically referred to above.

I acknowledge the duty to disclose information which is material to patentability as defined in 37 C.F.R. § 1.56, including for continuation-in-part applications, material information which became available between the filing date of the prior application and the national or PCT international filing date of the continuation-in-part application.

Authorization to Permit Access to Application by Participating Offices

If checked, the undersigned hereby grants the USPTO authority to provide the European Patent Office (EPO), the Japan Patent Office (JPO), the Korean Intellectual Property Office (KIPO), the World Intellectual Property Office (WIPO), and any other intellectual property offices in which a foreign application claiming priority to the above-identified patent application is filed access to the above-identified patent application. See 37 CFR 1.14(c) and (h). This box should not be checked if the applicant does not wish the EPO, JPO, KIPO, WIPO, or other intellectual property office in which a foreign application claiming priority to the above-identified patent application is filed to have access to the above-identified patent application.

In accordance with 37 CFR 1.14(h)(3), access will be provided to a copy of the above-identified patent application with respect to: 1) the above-identified patent application-as-filed; 2) any foreign application to which the above-identified patent application claims priority under 35 U.S.C. 119(a)-(d) if a copy of the foreign application that satisfies the certified copy requirement of 37 CFR 1.55 has been filed in the above-identified patent application; and 3) any U.S. application-as-filed from which benefit is sought in the above-identified patent application.

In accordance with 37 CFR 1.14(c), access may be provided to information concerning the date of filing the Authorization to Permit Access to Application by Participating Offices.

I hereby claim foreign priority benefits under 35 U.S.C. § 119(a)-(d) or (f), or § 365(b) of any foreign application(s) for patent, inventor's or plant breeder's rights certificate(s), or § 365(a) of any PCT international application which designated at least one country other than the United States of America, listed below, and have also identified below, by checking the box, any foreign application for patent, inventor's or plant breeder's rights certificate(s), or any PCT international application having a filing date before that of the application on which priority is claimed.

<i>Prior Foreign Application Number(s)</i>	<i>Country</i>	<i>Foreign Priority Date (MM/DD/YYYY)</i>	<i>Priority Not Claimed</i>	<i>Certified Copy Attached? (Yes/No)</i>

Declaration for Patent Application (cont'd.)

Atty. Docket No. NAR 0227 L

I hereby claim the benefit under Title 35, United States Code, § 119(e) of any United States provisional application(s) listed below.

<i>Application Number(s)</i>	<i>Filing Date (MM/DD/YYYY)</i>

I hereby claim the benefit under Title 35, United States Code, § 120 of any United States application(s) listed below.

<i>Application Number(s)</i>	<i>Filing Date (MM/DD/YYYY)</i>	<i>Status: Patented, Pending, Abandoned</i>

I hereby appoint the practitioners associated with Customer Number **02245** to prosecute this application and to transact all business in the Patent and Trademark Office connected therewith, and direct that all correspondence be addressed to that Customer Number. Telephone calls should be directed to (248) 358-4400.

02245

I hereby declare that all statements made herein of my own knowledge are true and that all statements made on information and belief are believed to be true; and further that these statements were made with the knowledge that willful false statements and the like so made are punishable by fine or imprisonment, or both, under Section 1001 of Title 18 of the United States Code and that such willful false statements may jeopardize the validity of the application or any patent issued thereon.

Full Name of Sole or First Inventor Bryon Hourmand

Inventor's signature _____ Date 07 / / 2011

Mailing address 1726 Creedside Lane, Vista, CA, 92081-4551

Residence Same as Mailing Address Citizenship US

Full Name of Second Joint Inventor John M. Washeleski

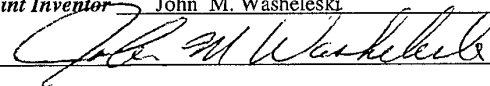
Inventor's signature  Date 07/26/2011

Mailing address 656 Holly Road, Cadillac, MI 49601

Residence Same as Mailing Address Citizenship US

Full Name of Third Joint Inventor Stephen R.W. Cooper

Inventor's signature  Date 8/1/2011

Mailing address 6599 W. Hogback Road, Fowlerville, MI 48835

Residence Same as Mailling Address Citizenship US

In re patent of:

BRYON HOURMAND, et al.

U.S. Patent No.: 5,796,183

Issue Date: August 18, 1998

For: CAPACITIVE RESPONSIVE ELECTRONIC SWITCHING CIRCUIT

Attorney Docket No.: NAR 0227 L

**STATEMENT OF PATENT OWNER
PURSUANT TO 37 CFR §1.324(b)(3) IN SUPPORT OF
REQUEST FOR CERTIFICATE CORRECTING INVENTORSHIP**

NORMAN A. RAUTIOLA states as follows:

1. I am the Chief Executive Officer of Nartron Corporation, 5000 North US-131, Reed City, Michigan 49677, the assignee of the joint inventors of U.S. Patent No. 5,796,183, issued August 18, 1998, for "CAPACITIVE RESPONSIVE ELECTRONIC SWITCHING CIRCUIT."

2. I am also the Manager of UUSI, LLC, a Michigan limited liability company, the assignee of U.S. Patent No. 5,796,183, as evidenced by the assignment recorded in the Assignment Branch of the US PTO at Reel 23679, Frame 803, recorded December 22, 2009.

3. I agree, on behalf of both Nartron Corporation and UUSI, LLC, to the change of inventorship of U.S. Patent No. 5,796,183, adding Stephen R. W. Cooper and John M. Washeleski as joint inventors with Byron Hourmand.

4. Through my review of Nartron Corporation documents, I became aware that the inventorship of the '183 patent was in error and needed to be corrected. Subsequently, steps were taken by me to seek correction of that error. Unfortunately, the refusal of the sole inventor, Mr. Hourmand, to acknowledge the contributions of his fellow workers, Messrs. Cooper and Washaleski, as coinventors of the '183 patent made it necessary for suit to be filed against Mr. Hourmand seeking correction of inventorship. Specifically, I authorized the filing of the civil action styled *Nartron Corp., et al v. Byron Hourmand*, Civil Action No. 1:10-DV-691-RHB, United States District Court for the Western District of Michigan (“the Michigan litigation”), for the purpose of obtaining an order under 35 U.S.C. §256, ¶2, for the Director of Patents and Trademarks to issue a certificate of correction of inventorship. That civil action resulted in a Consent Judgment with an accordant order.

5. Following resolution of the Michigan litigation, I again authorized counsel for Nartron Corporation and UUSI, LLC to request Byron Hourmand to execute an inventor’s oath with his two coinventors, and again Mr. Hourmand refused to do so.

6. Issuance of a certificate of correction of U.S. Patent No. 5,796,183 naming Mr. Byron Hourmand, Stephen R. W. Cooper and John M. Washeleski as joint inventors is necessary to preserve the rights of Nartron Corporation and UUSI, LLC and to prevent irreparable damage. A issuance of a Certificate of Correction correcting inventorship is thus respectfully requested.

DECLARATION PURSUANT TO 35 C.F.R. §1.68

Norman A. Rautiola, having been warned that willful false statements and the like are punishable by fine or imprisonment or both (18 U.S.C. §1001) and may jeopardize the validity of any application or the patent issuing thereon, states that

all statements made above on knowledge are true and all statements made on information and belief are believed to be true.



NORMAN A. RAUTIOLA
Chief Executive Officer
Nartron Corporation

Dated: 8-11-2011



NORMAN A. RAUTIOLA
Manager - UUSI, LLC

Dated: 8-11-2011

In re patent of:

BRYON HOURMAND, et al.

U.S. Patent No.: 5,796,183

Issue Date: August 18, 1998

For: CAPACITIVE RESPONSIVE ELECTRONIC SWITCHING CIRCUIT

Attorney Docket No.: NAR 0227 L

DECLARATION OF ROBERT C. J. TUTTLE

ROBERT C. J. TUTTLE makes the following declaration on personal knowledge, except where indicated to be upon information and belief, and states as follows:

1. I am a member in good standing of the State Bar of Michigan (P25222), and a registered patent attorney (Reg. No. 27,962).
2. The purpose of this declaration is to present facts pertinent to Byron Hourmand's refusal to sign an inventor's oath in relation to the request for a certificate of correction of the inventorship of U.S. Patent No. 5,796,183 ("the '183 patent").
3. The request for a certificate of correction, e-filed on September 14, 2010 as Appl. No. 08601268, is based on the Consent Judgment approved by the Court and entered in the case styled *Nartron Corp., et al v. Byron Hourmand*, Civil Action No. 1:10-DV-691-RHB, United States District Court for the Western District of Michigan ("the Civil Action"). A copy of the Consent Judgment is at Exhibit A.

4. Byron Hourmand was represented in the matter by Michael Fabiano, Esq. of Mazzerlla Caldarelli LLP, of San Diego, CA. Mr. Fabiano's e-mail forwarding Mr. Hourmand's approval of the Consent Judgment is attached at Exhibit B.

5. The Complaint in the Civil Action sets forth in factual detail (with contemporaneous documents as exhibits) the inventive contributions of John M. Washeleski and Stephen R. W. Cooper, Ph.D., as joint inventors of claims 20, 21 and 27 of the '183 patent. *See* Exhibit A, ¶5.

6. Mr. Hourmand, in consultation with his counsel, Mr. Fabiano, agreed to the Consent Judgment, including the order in paragraph C. that the Director of Patents and Trademarks issue a certificate of correction, pursuant to 35 U.S.C. §256, ¶2.

7. On March 14, 2011, Petitions Examiner Thurman Page refused the request for a certificate of correction on the ground that the request did not include a declaration signed by all joint inventors. *See* Exhibit C.

8. Many attempts were made to reach Mr. Page by telephone after March 14, 2011, but calls were not returned.¹

9. After being unable to reach Mr. Page for the next three months, we sought to obtain an inventors' oath signed by all three joint inventors of the '183 patent.

10. On June 21, 2011, I both called and e-mailed Mr. Fabiano to request that Mr. Hourmand sign an inventor's oath. *See* e-mail thread of Exhibit D, p. 2.

¹ I was informed by Ms. Sarah Svenson of the Petitions Office on July 21, 2011 that Mr. Page was on leave, and that is why he did not return calls.

11. I exchanged several e-mails with Mr. Fabiano on the status of this matter between June 21, 2011 and July 8, 2011. Exhibit D.

12. After hearing nothing from Mr. Fabiano, on July 14, 2011, I called him to inquire on the status of Mr. Hourmand's signature of the inventors' oath. He told me: "I no longer represent him. I don't know if anyone else represents him."

13. I have since learned that Mr. Hourmand sent a letter to the US PTO on July 8, 2011, in which he recants on the stipulated facts in the Consent Judgment. Exhibit E.

14. In these circumstances, namely, Mr. Hourmand's (i) dismissal of his counsel and (ii) recanting on stipulated facts in the Consent Judgment, it is submitted that the requirements of 35 C.F.R. §1.48(a)(3) (inventor oath for certificate of correction) and 35 C.F.R. §1.47(a) (diligent effort to obtain signature of recalcitrant joint inventor on oath), have been met.

DECLARATION PURSUANT TO 35 C.F.R. §1.68

Robert C. J. Tuttle, having been warned that willful false statements and the like are punishable by fine or imprisonment or both (18 U.S.C. 1001) and may jeopardize the validity of any application or the patent issuing thereon, states that all statements made above on knowledge are true and all statements made on information and belief are believed to be true.

Dated:

August 12, 2011

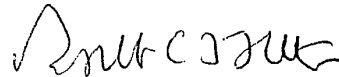

ROBERT C. J. TUTTLE

**UNITED STATES DISTRICT COURT
WESTERN DISTRICT OF MICHIGAN**

NARTRON CORPORATION)	
and UUSI, LLC,)	
Plaintiffs,)	
)	Civil Action No. 1:10-CV-691
v.)	
)	Honorable Robert Holmes Bell
)	
BYRON HOURMAND,)	United States District Judge
)	
Defendant.)	
)	

CONSENT JUDGMENT

Exhibit A

The parties hereto consent to the entry of a judgment, on the terms stated below, based on the following stipulation.

STIPULATION

1. Plaintiff Nartron Corporation was the owner at issuance of U.S. Patent No. 5,796,183, (“the ‘183 patent”), by assignment from defendant Byron Hourmand for good and valuable consideration.
2. Nartron has since assigned the ‘183 patent to plaintiff UUSI, LLC.
3. The ‘183 patent at issuance named Byron Hourmand as sole inventor.
4. The ‘183 patent at issuance erroneously omitted John M. Washeleski, of Cadillac, Michigan, and Stephen R. W. Cooper, of Fowlerville, Michigan, as joint inventors.
5. John M. Washeleski and Stephen R. W. Cooper are joint inventors of the matter of independent claims 20, 21 and 27 (and claims dependent therefrom) of the ‘183 patent, as proved by the pleaded matter in the Complaint, including exhibits thereto.
6. John M. Washeleski and Stephen R. W. Cooper have stated that they are joint inventors and their omission was without deceptive intention. (Complaint Exhibits J and K.)
7. John M. Washeleski and Stephen R. W. Cooper have assigned their interests as inventors of the ‘183 patent to plaintiff Nartron Corporation. (Complaint Exhibits H and I.)
8. Byron Hourmand agrees the error in omitting John M. Washeleski and Stephen R. W. Cooper as joint inventors of the ‘183 patent was without deceptive intention.
9. Each party has read this agreement and had the assistance of counsel.

JUDGMENT

A. The Court has jurisdiction over the subject matter of and the parties to this action.

B. John M. Washeleski and Stephen R. W. Cooper were erroneously omitted as joint inventors of U.S. Patent No. 5,796,183, ("the '183 patent"), and such error occurred without deceptive intention.

C. Under authority of 35 U.S.C. §256,¶2, the Court orders the Director of Patents and Trademarks to issue a certificate of correction adding John M. Washeleski, of Cadillac, Michigan, and Stephen R. W. Cooper, of Fowlerville, Michigan, as joint inventors of U.S. Patent No. 5,796,183.

D. Byron Hourmand, as assignor of the '183 patent for good and valuable consideration, is subject to the patent law doctrine of assignor estoppel from contesting the ownership, validity and enforceability of the '183 patent.

E. Defendant Byron Hourmand is therefore enjoined from contesting the ownership, validity or enforceability of U.S. Patent 5,796,183, along with persons in active concert or participation with Byron Hourmand, who receive actual notice by personal service or otherwise.

F. The parties shall bear their own attorney fees and costs.

IT IS SO ORDERED.

Dated: September 8, 2010

/s/ Robert Holmes Bell
HONORABLE ROBERT HOLMES BELL
United States District Judge

AGREED:

NARTRON CORPORATION



By: Norman A. Rautiola

Its: *PRESIDENT*

Date: August 26, 2010



Byron Hourmand

a/k/a Bahram Hourmand
a/k/a Joseph Oliver deMontfort

Date: *8/19/2010*

UUSI, LLC

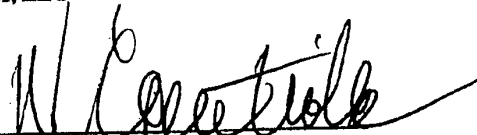

By: Norman A. Rautiola

Its: *MOR.*

Date: August 26, 2010

From: "Michael Fabiano" <mfabiano@mazzcal.com>
To: "Robert Tuttle" <RTUTTLE@brookskushman.com>
Date: 8/24/2010 2:14 PM
Subject: Nartron v. Hourmand
Attachments: Hourmand sig page.pdf

Mr. Tuttle,

Attached is Mr. Hourmand's executed signature page. Please return your client's signature page to me via e-mail or fax.

Thanks,

Michael D. Fabiano

Mazzarella Caldarelli LLP

550 West C Street, Suite 700

San Diego, California 92101

1-619-238-4900

mfabiano@mazzcal.com

This e-mail communication contains CONFIDENTIAL INFORMATION THAT ALSO MAY BE LEGALLY PRIVILEGED and that is intended only for the use of the intended recipient(s). If you are not an intended recipient of this communication, you are hereby notified that any use, dissemination, distribution, downloading or copying of this communication is strictly prohibited. If you have received this communication in error, please notify us immediately by e-mail, or by telephone at 1-619-238-4900, and delete this communication and destroy all copies. Thank you for your cooperation.

Exhibit B

AGREED:

NARTRON CORPORATION

By: _____



Byron Hourmand

Its:

a/k/a Bahram Hourmand
a/k/a Joseph Oliver deMontfort

Date:

Date: 8/19/2010

UUSI, LLC

By: _____

Its:

Date:



UNITED STATES PATENT AND TRADEMARK OFFICE

Commissioner for Patents
United States Patent and Trademark Office
P.O. Box 1450
Alexandria, VA 22313-1450
www.uspto.gov

**BROOKS KUSHMAN P.C.
1000 TOWN CENTER
TWENTY-SECOND FLOOR
SOUTHFIELD, MI 48075**

**MAILED
MAR 14 2011
OFFICE OF PETITIONS**

In re Patent No. 5,796,183 :
Issue Date: August 18, 1998 :
Application No. 08/601,268 : **ON PETITION**
Filed: January 31, 1996 :
Attorney Docket No. :

This is a decision on the petition filed September 14, 2010 under 37 CFR 1.323, which is being treated as a request under 37 CFR 1.324 to correct the name of the inventors by way of a Certificate of Correction.

The request is **DISMISSED**.

Petitioner request that the inventorship of this application be amended by the addition of **JOHN M. WASHELESKI** of Cadillac, Michigan, and **STEPHEN R. W. COOPER**, of Fowlerville, Michigan, based on the Consent Judgment dated September 8 2010 UNDER 35 USC 256.

The petition is dismissed for failure to submit an oath or declaration signed by all the inventors. See 37 CFR 1.63.
Telephone inquiries concerning this decision may be directed to the undersigned at (571) 272-0602. Inquiries regarding the issuance of a certificate of correction should be directed to the Certificate of Correction Branch at (571) 272-4200.

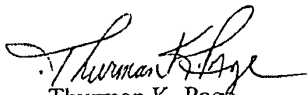
Thurman K. Page
Petitions Examiner
Office of Petitions

Robert C. Tuttle

From: Robert C. Tuttle
Sent: Friday, July 08, 2011 10:15 AM
To: hhuber@nartron.com
Subject: FW: Correcting the Inventorship of the Hourmand '183 Patent

From: mfabiano@mazzcal.com [mailto:mfabiano@mazzcal.com]
Sent: Friday, July 08, 2011 10:14 AM
To: Robert C. Tuttle
Subject: Re: Correcting the Inventorship of the Hourmand '183 Patent

No. I'll check with him.

Michael D. Fabiano
mfabiano@mazzcal.com
Sent from my BlackBerry

From: "Robert C. Tuttle" <rtuttle@brookskushman.com>
Date: Fri, 8 Jul 2011 12:48:43 +0000
To: Michael Fabiano <mfabiano@mazzcal.com>
Subject: RE: Correcting the Inventorship of the Hourmand '183 Patent

Hello Michael,

Any update on Mr. Hourmand's approval of the declaration?

Bob Tuttle

From: Michael Fabiano [mailto:mfabiano@mazzcal.com]
Sent: Monday, June 27, 2011 2:06 PM
To: Robert C. Tuttle
Subject: RE: Correcting the Inventorship of the Hourmand '183 Patent

Hi Bob,

I received your message below and your voice-mail message today. Your documents have been forwarded to Mr. Hourmand. I'll be in touch after he responds.

Thanks,

Michael D. Fabiano
Mazzarella Caldarelli LLP
550 West C Street, Suite 700
San Diego, California 92101
1-619-238-4900
mfabiano@mazzcal.com

This e-mail communication contains CONFIDENTIAL INFORMATION THAT ALSO MAY BE LEGALLY PRIVILEGED and that is intended only for the use of the intended recipient(s). If you are not an intended recipient of this communication, you are hereby notified that any use, dissemination, distribution, downloading or copying of this communication is strictly prohibited. If you have received this communication in error, please notify us immediately by e-mail, or by telephone at 1-619-238-4900, and delete this communication and destroy all copies. Thank you for your cooperation.

From: Robert C. Tuttle [mailto:rtuttle@brookskushman.com]
Sent: Tuesday, June 21, 2011 12:59 PM
To: Michael Fabiano
Subject: Correcting the Inventorship of the Hourmand '183 Patent

Hello Mike,

This e-mail is sent in follow-up to the voice mail message left with your office today.

As you may recall, you represented Byron Hourmand in a suit brought in the Western District of Michigan under 35 USC Sec. 256, para. 2 to amend the inventorship of the Hourmand '183 patent.

We worked out a Consent Judgment directing the Director of the US PTO to issue a certificate of correction.

Unfortunately, the bureaucratic jungle of the PTO has delayed the issuance of the certificate of correction on the demand that the request include a declaration executed by all inventors. See attached denial of petition.

For this reason, I would kindly ask your cooperation in securing Mr. Hourmand's signature on the attached declaration.

Another copy of the Consent Judgment is also attached for convenience of reference.

Thank you for your cooperation. Please call or e-mail with any questions or comments.

Bob Tuttle

248-226-2731

No virus found in this message.

Checked by AVG - www.avg.com

Version: 10.0.1382 / Virus Database: 1513/3717 - Release Date: 06/21/11

1726 Creekside Ln.
Vista, CA 92081

Thurman K. Page
Petitions Examiner
Office of Petitions
United States Patent and Trademark Office
P.O. BOX 1450
Alexandria, VA 22313-1450

RECEIVED

JUL 11 2011

OFFICE OF PETITIONS

In re Patent No.: 5,796,183
Issue Date: August 18, 1998
Application No.: 08/601,268
Filed: January 31, 1996

Date of this letter: July, 8, 2011

Dear Thurman K. Page:

I received an email from Robert C. Tuttle, one of Nartron Corporation's attorneys, asking me to sign (under oath) a Declaration for Patent Application and Power of Attorney, to include John M. Washeleski and Stephen R. W. Cooper. I CANNOT do that since that would be a false statement. I was the sole inventor on patent 5,796,183 and adding Washeleski and Cooper to the patent as co-inventors would be a lie. I signed the Consent form because Nartron's attorneys had been threatening me by lawsuit and thousands of dollars in attorney fees. I had no money to fight them and I signed the consent to get them off my back since they had been harassing me since December of 2008. Now, I am getting this Declaration form, and I am being asked to sign under oath and if a false statement is made, it is punishable by prison and fines. I simply cannot sign, both morally and legally.

If you have any questions, please let me know.

Sincerely,

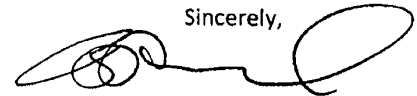

Byron Hourmand

Exhibit E

Electronic Patent Application Fee Transmittal

Application Number:	08601268			
Filing Date:	31-Jan-1996			
Title of Invention:	CAPACITIVE RESPONSIVE ELECTRONIC SWITCHING CIRCUIT			
First Named Inventor/Applicant Name:	BYRON HOURMAND			
Filer:	John E. Nemazi/Carolyn Bielaniec			
Attorney Docket Number:	NAR0227L			
Filed as Large Entity				
Utility under 35 USC 111(a) Filing Fees				
Description	Fee Code	Quantity	Amount	Sub-Total in USD(\$)
Basic Filing:				
Pages:				
Claims:				
Miscellaneous-Filing:				
Petition:				
Patent-Appeals-and-Interference:				
Post-Allowance-and-Post-Issuance:				
Certificate of correction	1811	1	100	100
Extension-of-Time:				

Description	Fee Code	Quantity	Amount	Sub-Total in USD(\$)
Miscellaneous:				
Total in USD (\$)				100

Electronic Acknowledgement Receipt

EFS ID:	10771652
Application Number:	08601268
International Application Number:	
Confirmation Number:	3176
Title of Invention:	CAPACITIVE RESPONSIVE ELECTRONIC SWITCHING CIRCUIT
First Named Inventor/Applicant Name:	BYRON HOURMAND
Customer Number:	22045
Filer:	John E. Nemazi/Carolyn Bielaniec
Filer Authorized By:	John E. Nemazi
Attorney Docket Number:	NAR0227L
Receipt Date:	19-AUG-2011
Filing Date:	31-JAN-1996
Time Stamp:	13:29:09
Application Type:	Utility under 35 USC 111(a)

Payment information:

Submitted with Payment	yes
Payment Type	Deposit Account
Payment was successfully received in RAM	\$100
RAM confirmation Number	11612
Deposit Account	023978
Authorized User	

The Director of the USPTO is hereby authorized to charge indicated fees and credit any overpayment as follows:

Charge any Additional Fees required under 37 C.F.R. Section 1.16 (National application filing, search, and examination fees)

Charge any Additional Fees required under 37 C.F.R. Section 1.17 (Patent application and reexamination processing fees)

File Listing:					
Document Number	Document Description	File Name	File Size(Bytes)/ Message Digest	Multi Part /.zip	Pages (if appl.)
1	Request for Certificate of Correction	Request_Certificate_Correction.pdf	619744 <small>b3ccc21b739d1602fe5f7707ff3c30885db24a9</small>	no	21
Warnings:					
Information:					
2	Fee Worksheet (SB06)	fee-info.pdf	30254 <small>160b359bcab26adad4105e8ad0635ee998e7a437</small>	no	2
Warnings:					
Information:					
Total Files Size (in bytes):			649998		
<p>This Acknowledgement Receipt evidences receipt on the noted date by the USPTO of the indicated documents, characterized by the applicant, and including page counts, where applicable. It serves as evidence of receipt similar to a Post Card, as described in MPEP 503.</p> <p><u>New Applications Under 35 U.S.C. 111</u> If a new application is being filed and the application includes the necessary components for a filing date (see 37 CFR 1.53(b)-(d) and MPEP 506), a Filing Receipt (37 CFR 1.54) will be issued in due course and the date shown on this Acknowledgement Receipt will establish the filing date of the application.</p> <p><u>National Stage of an International Application under 35 U.S.C. 371</u> If a timely submission to enter the national stage of an international application is compliant with the conditions of 35 U.S.C. 371 and other applicable requirements a Form PCT/DO/EO/903 indicating acceptance of the application as a national stage submission under 35 U.S.C. 371 will be issued in addition to the Filing Receipt, in due course.</p> <p><u>New International Application Filed with the USPTO as a Receiving Office</u> If a new international application is being filed and the international application includes the necessary components for an international filing date (see PCT Article 11 and MPEP 1810), a Notification of the International Application Number and of the International Filing Date (Form PCT/RO/105) will be issued in due course, subject to prescriptions concerning national security, and the date shown on this Acknowledgement Receipt will establish the international filing date of the application.</p>					



UNITED STATES PATENT AND TRADEMARK OFFICE

Commissioner for Patents
United States Patent and Trademark Office
P.O. Box 1450
Alexandria, VA 22313-1450
www.uspto.gov

**BROOKS KUSHMAN P.C.
1000 TOWN CENTER
TWENTY-SECOND FLOOR
SOUTHFIELD, MI 48075**

MAILED

MAR 14 2011

OFFICE OF PETITIONS

In re Patent No. 5,796,183
Issue Date: August 18, 1998
Application No. 08/601,268
Filed: January 31, 1996

:
:
:
:
:

NOTICE

This is a notice regarding your request for acceptance of a fee deficiency submission under 37 CFR 1.28.

The Office no longer investigates or rejects original or reissue applications under 37 CFR 1.56. **1098 Off. Gaz. Pat. Office 502 (January 3, 1989)**. Therefore, nothing in this Notice is intended to imply that an investigation was done.

Your fee deficiency submission under 37 CFR 1.28 is hereby **ACCEPTED**.

This application is no longer entitled to small entity status. Accordingly, all future fees paid in this application must be paid at the large entity rate.

Inquiries related to this communication should be directed to the undersigned at (571) 272-0602.

Thurman K. Page
Petitions Examiner
Office of Petitions



UNITED STATES PATENT AND TRADEMARK OFFICE

Commissioner for Patents
United States Patent and Trademark Office
P.O. Box 1450
Alexandria, VA 22313-1450
www.uspto.gov

**BROOKS KUSHMAN P.C.
1000 TOWN CENTER
TWENTY-SECOND FLOOR
SOUTHFIELD, MI 48075**

**MAILED
MAR 14 2011
OFFICE OF PETITIONS**

In re Patent No. 5,796,183 :
Issue Date: August 18, 1998 :
Application No. 08/601,268 : **ON PETITION**
Filed: January 31, 1996 :
Attorney Docket No. :

This is a decision on the petition filed September 14, 2010 under 37 CFR 1.323, which is being treated as a request under 37 CFR 1.324 to correct the name of the inventors by way of a Certificate of Correction.

The request is **DISMISSED**.

Petitioner request that the inventorship of this application be amended by the addition of **JOHN M. WASHELESKI** of Cadillac, Michigan, and **STEPHEN R. W. COOPER**, of Fowlerville, Michigan, based on the Consent Judgment dated September 8 2010 UNDER 35 USC 256.

The petition is dismissed for failure to submit an oath or declaration signed by all the inventors. See 37 CFR 1.63.

Telephone inquiries concerning this decision may be directed to the undersigned at (571) 272-0602. Inquiries regarding the issuance of a certificate of correction should be directed to the Certificate of Correction Branch at (571) 272-4200.

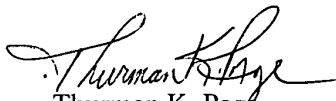
Thurman K. Page
Petitions Examiner
Office of Petitions

IN THE UNITED STATES PATENT AND TRADEMARK OFFICE

In re patent of:

BRYON HOURMAND, et al.

U.S. Patent No.: 5,796,183

Issue Date: August 18, 1998

For: CAPACITIVE RESPONSIVE ELECTRONIC SWITCHING CIRCUIT

Attorney Docket No.: NAR 0227 L

REQUEST FOR "CERTIFICATE OF CORRECTION"

Attention Certificate of Correction Branch
Commissioner for Patents
U.S. Patent & Trademark Office
P.O. Box 1450
Alexandria, VA 22313-1450

Sir:

It is requested that a Certificate of Correction be issued for the above-identified patent under the provisions of 37 C.F.R. § 1.324, 35 U.S.C. 256 and the attached Court Order. The corrections noted are as follows:

The inventorship of this patent is amended to add the following joint inventors:

John M. Washeleski, of Cadillac, Michigan; and

Stephen R. W. Cooper, of Fowlerville, Michigan

Enclosed herewith is a copy of the form for Certificate of Correction (PTO/SB/44) together with a copy of the court order correcting inventorship. The Commissioner is hereby authorized to charge any additional fees to our Deposit Account No. 02-3978.

Respectfully submitted,

BRYON HOURMAND, et al.

By /John E. Nemazi/

John E. Nemazi

Reg. No. 30,876

Attorney/Agent for Applicant

Date: December 8, 2010

BROOKS KUSHMAN P.C.

1000 Town Center, 22nd Floor

Southfield, MI 48075-1238

Phone: (248) 358-4400

Fax: (248) 358-3351

**UNITED STATES PATENT AND TRADEMARK OFFICE
CERTIFICATE OF CORRECTION**

PATENT NO. : 5,796,183
APPLICATION NO. : 601,268
ISSUE DATE : August 18, 1998
INVENTOR(S) : Byron Hourmand et al

Page 1 of 1

It is certified that an error appears or errors appear in the above-identified patent and that said Letters Patent is hereby corrected as shown below:

The inventorship of this patent is amended to add the following joint inventors:

John M. Washeleski, of Cadillac, Michigan, and

Stephen R. W. Cooper, of Fowlerville, Michigan.

MAILING ADDRESS OF SENDER:

BROOKS KUSHMAN P.C.
1000 Town Center, 22nd Floor
Southfield, Michigan 48075-1238

This collection of information is required by 37 CFR 1.322, 1.323, and 1.324. The information is required to obtain or retain a benefit by the public which is to file (and by the USPTO to process) an application. Confidentiality is governed by 35 U.S.C. 122 and 37 CFR 1.14. This collection is estimated to take 1.0 hour to complete, including gathering, preparing, and submitting the completed application form to the USPTO. Time will vary depending upon the individual case. Any comments on the amount of time you require to complete this form and/or suggestions for reducing this burden, should be sent to the Chief Information Officer, U.S. Patent & Trademark Office, U.S. Department of Commerce, P.O. Box 1450, Alexandria, VA 22313-1450. DO NOT SEND FEES OR COMPLETED FORMS TO THIS ADDRESS. SEND TO: Attention Certificate of Corrections Branch, Commissioner for Patents, P.O. Box 1450, Alexandria, VA 22313-1450.

**UNITED STATES DISTRICT COURT
WESTERN DISTRICT OF MICHIGAN**

NARTRON CORPORATION)	
and UUSI, LLC,)	
Plaintiffs,)	
)	Civil Action No. 1:10-CV-691
v.)	
)	Honorable Robert Holmes Bell
)	
BYRON HOURMAND,)	United States District Judge
)	
Defendant.)	
)	

CONSENT JUDGMENT

The parties hereto consent to the entry of a judgment, on the terms stated below, based on the following stipulation.

STIPULATION

1. Plaintiff Nartron Corporation was the owner at issuance of U.S. Patent No. 5,796,183, (“the ‘183 patent”), by assignment from defendant Byron Hourmand for good and valuable consideration.

2. Nartron has since assigned the ‘183 patent to plaintiff UUSI, LLC.

3. The ‘183 patent at issuance named Byron Hourmand as sole inventor.

4. The ‘183 patent at issuance erroneously omitted John M. Washeleski, of Cadillac, Michigan, and Stephen R. W. Cooper, of Fowlerville, Michigan, as joint inventors.

5. John M. Washeleski and Stephen R. W. Cooper are joint inventors of the matter of independent claims 20, 21 and 27 (and claims dependent therefrom) of the ‘183 patent, as proved by the pleaded matter in the Complaint, including exhibits thereto.

6. John M. Washeleski and Stephen R. W. Cooper have stated that they are joint inventors and their omission was without deceptive intention. (Complaint Exhibits J and K.)

7. John M. Washeleski and Stephen R. W. Cooper have assigned their interests as inventors of the ‘183 patent to plaintiff Nartron Corporation. (Complaint Exhibits H and I.)

8. Byron Hourmand agrees the error in omitting John M. Washeleski and Stephen R. W. Cooper as joint inventors of the ‘183 patent was without deceptive intention.

9. Each party has read this agreement and had the assistance of counsel.

JUDGMENT

A. The Court has jurisdiction over the subject matter of and the parties to this action.

B. John M. Washeleski and Stephen R. W. Cooper were erroneously omitted as joint inventors of U.S. Patent No. 5,796,183, (“the ‘183 patent”), and such error occurred without deceptive intention.

C. Under authority of 35 U.S.C. §256,¶2, the Court orders the Director of Patents and Trademarks to issue a certificate of correction adding John M. Washeleski, of Cadillac, Michigan, and Stephen R. W. Cooper, of Fowlerville, Michigan, as joint inventors of U.S. Patent No. 5,796,183.

D. Byron Hourmand, as assignor of the ‘183 patent for good and valuable consideration, is subject to the patent law doctrine of assignor estoppel from contesting the ownership, validity and enforceability of the ‘183 patent.

E. Defendant Byron Hourmand is therefore enjoined from contesting the ownership, validity or enforceability of U.S. Patent 5,796,183, along with persons in active concert or participation with Byron Hourmand, who receive actual notice by personal service or otherwise.

F. The parties shall bear their own attorney fees and costs.

IT IS SO ORDERED.

Dated: September 8, 2010

/s/ Robert Holmes Bell
HONORABLE ROBERT HOLMES BELL
United States District Judge

AGREED:

NARTRON CORPORATION



By: Norman A. Rautiola

Its: *PRESIDENT*

Date: August 26, 2010



Byron Hourmand

a/k/a Bahram Hourmand
a/k/a Joseph Oliver deMontfort

Date: *8/19/2010*

UUSI, LLC

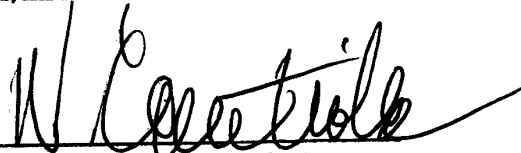

By: Norman A. Rautiola

Its: *MGR.*

Date: August 26, 2010

Electronic Acknowledgement Receipt

EFS ID:	8968964
Application Number:	08601268
International Application Number:	
Confirmation Number:	3176
Title of Invention:	CAPACITIVE RESPONSIVE ELECTRONIC SWITCHING CIRCUIT
First Named Inventor/Applicant Name:	BYRON HOURMAND
Customer Number:	22045
Filer:	John E. Nemazi/Maryann Kostiuk
Filer Authorized By:	John E. Nemazi
Attorney Docket Number:	NAR0227L
Receipt Date:	06-DEC-2010
Filing Date:	31-JAN-1996
Time Stamp:	12:58:28
Application Type:	Utility under 35 USC 111(a)

Payment information:

Submitted with Payment	no
------------------------	----

File Listing:

Document Number	Document Description	File Name	File Size(Bytes)/ Message Digest	Multi Part /.zip	Pages (if appl.)
1	Request for Certificate of Correction	Corrected_Request_for_Certificate_of_Correction.pdf	234467 e335dfd7c8695ea3d20cc8943453038dff7cb45	no	7

Warnings:

Information:

This Acknowledgement Receipt evidences receipt on the noted date by the USPTO of the indicated documents, characterized by the applicant, and including page counts, where applicable. It serves as evidence of receipt similar to a Post Card, as described in MPEP 503.

New Applications Under 35 U.S.C. 111

If a new application is being filed and the application includes the necessary components for a filing date (see 37 CFR 1.53(b)-(d) and MPEP 506), a Filing Receipt (37 CFR 1.54) will be issued in due course and the date shown on this Acknowledgement Receipt will establish the filing date of the application.

National Stage of an International Application under 35 U.S.C. 371

If a timely submission to enter the national stage of an international application is compliant with the conditions of 35 U.S.C. 371 and other applicable requirements a Form PCT/DO/EO/903 indicating acceptance of the application as a national stage submission under 35 U.S.C. 371 will be issued in addition to the Filing Receipt, in due course.

New International Application Filed with the USPTO as a Receiving Office

If a new international application is being filed and the international application includes the necessary components for an international filing date (see PCT Article 11 and MPEP 1810), a Notification of the International Application Number and of the International Filing Date (Form PCT/RO/105) will be issued in due course, subject to prescriptions concerning national security, and the date shown on this Acknowledgement Receipt will establish the international filing date of the application.



UNITED STATES PATENT AND TRADEMARK OFFICE

UNITED STATES DEPARTMENT OF COMMERCE
United States Patent and Trademark Office
Address: COMMISSIONER FOR PATENTS
P.O. Box 1450
Alexandria, Virginia 22313-1450
www.uspto.gov

APPLICATION NUMBER	FILING OR 371(C) DATE	FIRST NAMED APPLICANT	ATTY. DOCKET NO./TITLE
08/601,268	01/31/1996	BYRON HOURMAND	NAR01-P-310

CONFIRMATION NO. 3176

POWER OF ATTORNEY NOTICE

PRICE HENEVELD COOPER
DEWITT & LITTON
695 KENMOOR DRIVE SE
P O BOX 2567
GRAND RAPIDS, MI 49501



Date Mailed: 12/02/2010

NOTICE REGARDING CHANGE OF POWER OF ATTORNEY

This is in response to the Power of Attorney filed 11/24/2010.

- The Power of Attorney to you in this application has been revoked by the assignee who has intervned as provided by 37 CFR 3.71. Future correspondence will be mailed to the new address of record(37 CFR 1.33).

/sharris/

Office of Data Management, Application Assistance Unit (571) 272-4000, or (571) 272-4200, or 1-888-786-0101



UNITED STATES PATENT AND TRADEMARK OFFICE

UNITED STATES DEPARTMENT OF COMMERCE
United States Patent and Trademark Office
Address: COMMISSIONER FOR PATENTS
P.O. Box 1450
Alexandria, Virginia 22313-1450
www.uspto.gov

APPLICATION NUMBER	FILING OR 371(C) DATE	FIRST NAMED APPLICANT	ATTY. DOCKET NO./TITLE
08/601,268	01/31/1996	BYRON HOURMAND	NAR0227L

CONFIRMATION NO. 3176

POA ACCEPTANCE LETTER

22045
BROOKS KUSHMAN P.C.
1000 TOWN CENTER
TWENTY-SECOND FLOOR
SOUTHFIELD, MI 48075



Date Mailed: 12/02/2010

NOTICE OF ACCEPTANCE OF POWER OF ATTORNEY

This is in response to the Power of Attorney filed 11/24/2010.

The Power of Attorney in this application is accepted. Correspondence in this application will be mailed to the above address as provided by 37 CFR 1.33.

/sharris/

Office of Data Management, Application Assistance Unit (571) 272-4000, or (571) 272-4200, or 1-888-786-0101

POWER OF ATTORNEY TO PROSECUTE APPLICATIONS BEFORE THE USPTO

I hereby revoke all previous powers of attorney given in the application identified in the attached statement under 37 CFR 3.73(b).

I hereby appoint:

Practitioners associated with the Customer Number:

22045

OR

Practitioner(s) named below (if more than ten patent practitioners are to be named, then a customer number must be used).

Name	Registration Number	Name	Registration Number

as attorney(s) or agent(s) to represent the undersigned before the United States Patent and Trademark Office (USPTO) in connection with any and all patent applications assigned only to the undersigned according to the USPTO assignment records or assignment documents attached to this form in accordance with 37 CFR 3.73(b).

Please change the correspondence address for the application identified in the attached statement under 37 CFR 3.73(b) to:

The address associated with Customer Number:

22045

OR

<input type="checkbox"/> Firm or Individual Name			
Address			
City	State	Zip	
Country			
Telephone	Email		

Assignee Name and Address:

UUSI, LLC
5000 North US-131
Reed City, MI 49677-0207

A copy of this form, together with a statement under 37 CFR 3.73(b) (Form PTO/SB/96 or equivalent) is required to be filed in each application in which this form is used. The statement under 37 CFR 3.73(b) may be completed by one of the practitioners appointed in this form if the appointed practitioner is authorized to act on behalf of the assignee, and must identify the application in which this Power of Attorney is to be filed.

SIGNATURE of Assignee of Record

The individual whose signature and title is supplied below is authorized to act on behalf of the assignee

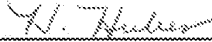
Signature		Date	11/16/10
Name	Heather Huber	Telephone	231.832.5513
Title	Vice-President		

This collection of information is required by 37 CFR 1.31, 1.32 and 1.33. The information is required to obtain or retain a benefit by the public which is to file (and by the USPTO to process) an application. Confidentiality is governed by 35 U.S.C. 122 and 37 CFR 1.11 and 1.14. This collection is estimated to take 3 minutes to complete, including gathering, preparing, and submitting the completed application form to the USPTO. Time will vary depending upon the individual case. Any comments on the amount of time you require to complete this form and/or suggestions for reducing this burden, should be sent to the Chief Information Officer, U.S. Patent and Trademark Office, U.S. Department of Commerce, P.O. Box 1450, Alexandria, VA 22313-1450. DO NOT SEND FEES OR COMPLETED FORMS TO THIS ADDRESS. SEND TO: Commissioner for Patents, P.O. Box 1450, Alexandria, VA 22313-1450.

If you need assistance in completing the form, call 1-800-PTO-9199 and select option 2.

IN THE UNITED STATES PATENT AND TRADEMARK OFFICE

U.S. Patent No.: 5,796,183

Issue Date: Aug. 18, 1998

For: **CAPACITIVE RESPONSIVE ELECTRONIC SWITCHING CIRCUIT**

Attorney Docket No.: NAR 0227L

STATEMENT UNDER 37 C.F.R. § 3.73(b)
ESTABLISHING RIGHT OF ASSIGNEE TO TAKE ACTION

Commissioner for Patents
U.S. Patent & Trademark Office
P.O. Box 1450
Alexandria, VA 22313-1450

Sir:

UUSI, LLC, a corporation having its principal offices at 5000 North U.S. Highway 131 Reed City, Michigan 49677, is the assignee of the entire right, title and interest in the above-identified application, U.S. Patent No. 5,796,183, by virtue of an assignment from Nartron Corporation to UUSI, LLC thereof dated December 17, 2009. The assignment was recorded in the U.S. Patent and Trademark Office on, December 22, 2009 at Reel 023679, Frames 0803.

By virtue of an assignment from Byron Hourmand to Nartron Corporation thereof dated January 31, 1996. The assignment was recorded in the U.S. Patent and Trademark Office on, February 4, 1997 at Reel 008443, Frames 0749.

By virtue of an assignment from Byron Hourmand to Nartron Corporation thereof dated January 31, 1996. The assignment was recorded in the U.S. Patent and Trademark Office on, January 31, 1996 at Reel 008254, Frames 0496.

The undersigned (whose title is supplied below) is empowered to act on behalf of UUSI, LLC.

Respectfully submitted,
UUSI, LLC.

By /John E. Nemazi/
John E. Nemazi
Reg. No. 30,876
Attorney for Applicant

Date: November 23, 2010

BROOKS KUSHMAN P.C.
1000 Town Center, 22nd Floor
Southfield, MI 48075-1238
Phone: 248-358-4400
Fax: 248-358-3351

Electronic Acknowledgement Receipt

EFS ID:	8899185
Application Number:	08601268
International Application Number:	
Confirmation Number:	3176
Title of Invention:	CAPACITIVE RESPONSIVE ELECTRONIC SWITCHING CIRCUIT
First Named Inventor/Applicant Name:	BYRON HOURMAND
Correspondence Address:	PRICE HENEVELD COOPER DEWITT & LITTON 695 KENMOOR DRIVE SE P O BOX 2567 GRAND RAPIDS MI 49501 US - -
Filer:	John E. Nemazi/Maryann Kostiuk
Filer Authorized By:	John E. Nemazi
Attorney Docket Number:	NAR01-P-310
Receipt Date:	24-NOV-2010
Filing Date:	31-JAN-1996
Time Stamp:	09:10:59
Application Type:	Utility under 35 USC 111(a)

Payment information:

Submitted with Payment	no
------------------------	----

File Listing:

Document Number	Document Description	File Name	File Size(Bytes)/ Message Digest	Multi Part /.zip	Pages (if appl.)
1	Power of Attorney	Signed_POA.pdf	545481	no	1
			e158d12d381073e5efd323d73006a9eac414dcd		
Warnings:					
Information:					
2	Assignee showing of ownership per 37 CFR 3.73(b).	Statement.pdf	53654	no	2
			103d74c08c8b2c9293c359b0cc4aa92b6c3f0003		
Warnings:					
Information:					
Total Files Size (in bytes):			599135		
<p>This Acknowledgement Receipt evidences receipt on the noted date by the USPTO of the indicated documents, characterized by the applicant, and including page counts, where applicable. It serves as evidence of receipt similar to a Post Card, as described in MPEP 503.</p> <p><u>New Applications Under 35 U.S.C. 111</u> If a new application is being filed and the application includes the necessary components for a filing date (see 37 CFR 1.53(b)-(d) and MPEP 506), a Filing Receipt (37 CFR 1.54) will be issued in due course and the date shown on this Acknowledgement Receipt will establish the filing date of the application.</p> <p><u>National Stage of an International Application under 35 U.S.C. 371</u> If a timely submission to enter the national stage of an international application is compliant with the conditions of 35 U.S.C. 371 and other applicable requirements a Form PCT/DO/EO/903 indicating acceptance of the application as a national stage submission under 35 U.S.C. 371 will be issued in addition to the Filing Receipt, in due course.</p> <p><u>New International Application Filed with the USPTO as a Receiving Office</u> If a new international application is being filed and the international application includes the necessary components for an international filing date (see PCT Article 11 and MPEP 1810), a Notification of the International Application Number and of the International Filing Date (Form PCT/RO/105) will be issued in due course, subject to prescriptions concerning national security, and the date shown on this Acknowledgement Receipt will establish the international filing date of the application.</p>					

RAM Fee History
Query
Revenue Accounting and Management

Name/Number: 5796183

Total Records Found: 5

Start Date: Any Date

End Date: Any Date

Accounting Date	Sequence Num.	Fee Type	Fee Code	Fee Amount	Mailroom Date	Payment Method
11/05/2010	0000023	2	1599	\$3,385.00	11/04/2010	CC
02/22/2010	00008668	2	2553	\$2,055.00	02/18/2010	DA 032641
02/27/2006	0000010	2	2552	\$1,150.00	02/21/2006	CK
01/14/2002	00000123	2	183	\$880.00	11/02/2001	CK
01/29/1999	00000380	2	145	\$100.00	01/25/1999	CK

INITIAL SCREENING OF INCOMING PAPERS CHECKLIST

Reviewer: CB Date: 11/4/10

APPLICATION NO. 08/601268

1. PETITION TYPE	CODE
<u> </u> R137(a) Petition	<u> </u> 501
<u> </u> R137(a) Petition (Issue Fee/Dwgs)	<u> </u> 509
<u> </u> R137(b) Petition	<u> </u> 502
<u> </u> R137(b) Petition (IFEE/DWG)	<u> </u> 510
<u> </u> R53(e) Filing Date	<u> </u> 412
<u> </u> R137(f) Petition	<u> </u> 536
<u> </u> R183 Pat. (waive R67 sup. dec.)	<u> </u> 516
<u> </u> R182 Petition (inv. name chg., order of inv., atty/assig. name chg., dup. let. pat.)	<u> </u> 519
<u> </u> R182 Petition - (omit items w/postcard)	<u> </u> 520
<u> </u> R183(susp./waive ex. rule, R59)	<u> </u> 503
<u> </u> R378(b/e) Petition	<u> </u> 532
<u> </u> R378(c) Petition	<u> </u> 533
<u> </u> R377 Petition	<u> </u> 521
<u> </u> R381(b) Petition	<u> </u> 523
<u> </u> R181 Petition (rev. non-exam)	<u> </u> 515
<u> </u> R181 Petition (rev.exam)	<u> </u> 504

PETITION TYPE	CODE
<u> </u> R28c Petition (small to large)	<u> </u> 321
<u> </u> R28c Petition (large to small)	<u> </u> 320
<u> </u> R47 Petition	<u> </u> 313
<u> </u> R53 Petition (Lost App., postcard rec., inc. by ref., conversions, misnum/mislabel. dwgs)	<u> </u> 408
<u> </u> R10(d) Exp. Mail FD (USPS)	<u> </u> 411
<u> </u> R10(c/e) Exp. Mail FD	<u> </u> 416
<u> </u> R53 Pet. conv. to/from prov.	<u> </u> 527
<u> </u> R7B(a)(3)/(6) Petition	<u> </u> 535
<u> </u> R55(c) Petition	<u> </u> 535
<u> </u> R55(a) Petition	<u> </u> 507
<u> </u> R183 Petition (corr.data 85b/pat)	<u> </u> 538
<u> </u> R314 Petition	<u> </u> 508
<u> </u> Pet. W/D Abn	<u> </u> 525
<u> </u> R705(b) PTA-Bef iss	<u> </u> 550
<u> </u> R705(d) PTA-Aft iss	<u> </u> 551
<u> </u> R705(c) Reinstate red. term.	<u> </u> 552
<u> </u> R701 PTE	<u> </u> 553
<u> </u> Other	<u> </u>

2. LIST PAPERS FILED WITH PETITIONS

<u> </u> PreAmdt/Amdt	<u> </u> CPA	<u> </u> Associate POA
<u> </u> Filing Fees	<u> </u> RCE	<u> </u> Terminal Disclaimer
<u> </u> Reply/Arguments	<u> </u> IDS	<u> </u> Change of Address
<u> </u> Election	<u> </u> 129(a) Submsn	<u> </u> Revocation/POA
<u> </u> Notice of Appeal	<u> </u> Issue Fee	<u> </u> Priority Documents
<u> </u> Brief (3)	<u> </u> Drawings	<u> </u> Request C of C
<u> </u> Reply Brief	<u> </u> Oath/Decl & POA	<u> </u> Rule 312 Amdt
<u> </u> Declaration R132	<u> </u> Ext Time ()	<u> </u> Statement 3.73b

Other Papers _____

3. Is paper a petition to withdraw holding of abandonment: yes no
 If so, send paper and/or file to appropriate location (Note: remove any flag set first):

- a. Nonreceipt of action from TC or assertion that reply was timely filed:
Send paper to TC _____
- b. Nonreceipt of Missing Parts Notice or assertion that reply was timely filed:
Send paper to -OIRP - CP2-5B26- - ATTN: Doshie Day
- c. Assertion of timely payment of issue fee and/or submission of drawings:
Send petition to Office of Publications: ATTN: Tom Hawkins
- d. Other _____

4. Other: _____
 If not handled in Office of Petitions, send paper to appropriate location.

5. Is petition accompanied by assignment papers, fee address, or other paper which needs to be sent to another location? yes no. If so, make copy of assignment papers, fee address, or other paper; mail original to proper location and place copy in file with an indication that the

IN THE UNITED STATES PATENT AND TRADEMARK OFFICE

In Re Patent No.: 5,796,183

Date: August 18, 1998

RECEIVED

Application No.: 08/601,268

Filing Date: January 31, 1996

NOV 08 2010

Title: CAPACITIVE RESPONSIVE ELECTRONIC SWITCHING CIRCUIT

OFFICE OF PETITIONS

Docket No.: 16-814

CERTIFICATE OF FACSIMILE	
I hereby certify that this paper is being faxed today to the Maintenance Fee Branch, 2051 Jamieson Ave., Suite 300, VA 22314	
On:	11-4-10
By:	<i>Carrie A. Lewis</i> Carrie A. Lewis

11/05/2010 DALLEN 00000020 5796183

01 FC:1599

3385.00 OP

Director of the U.S. Patent and Trademark Office
Attn: Maintenance Fees
2051 Jamieson Avenue, Suite 300
Alexandria, VA 22314
571-273-6500

NOTIFICATION UNDER 37 CFR 1.27(g) OF ERROR IN PAYMENT OF SMALL ENTITY FEE FOR U.S. PAT. NO. 5,796,183

Dear Sir or Madam:

U.S. Patent No. 5,796,183 (hereinafter "the '183 patent") issued on August 18, 1998.

The assignee of record of the '183 patent is UUSI, LLC. (hereinafter "UUSI").

At the time the '183 patent was filed and through the time of issuance of the '183 patent, Nartron Corporation, a predecessor in interest to UUSI was a small entity, as the total number of employees, including all affiliates, subsidiaries and related companies under the control of Nartron was less than 500 employees. Thus, small entity status was claimed upon filing of the application that matured into the '183 patent and all Patent Office fees associated with the prosecution of the '183 patent were properly paid under small entity status.

As explained on the accompanying Verified Statement under 37 CFR 1.28(c), due to licensing of the '183 patent to an entity not entitled to small entity status under 37 CFR 1.27 the

second (8th year) and third (12th year) maintenance fees were erroneously paid as a small entity and should have been paid as a large entity.

The total deficiency of \$3385.00 (enclosed herewith) represents the amount of fees due to the erroneous payment. As show on the accompanying Verified Statement, this deficiency represents the 8 year maintenance fee under the now current fee schedule as a large entity, namely, \$2480.00, less the amount actually paid as a small entity, namely, \$1150.00, in addition to the amount for a 12 year maintenance fee under the now current fee schedule as a large entity, namely, \$4110, less the amount actually paid as a small entity, namely, \$2055. Accordingly, authorization to charge a credit card in the amount of \$3385 is enclosed herewith. Please charge any additional fees or credit any overpayments to deposit account number 20-0090.

If any fees additional fees are determined to be due in connection with filing this document or any other document required to be filed during the remaining term of the '183 patent, the Commissioner is authorized to charge those fees to deposit account no. 20-0090. If any extension of time is required in connection with filing this document or any document filed during the remaining term of the '183 patent, such petition for extension of time is hereby made and is respectfully requested.

Respectfully submitted,

Date: Nov 4, 2010



Stephen J. Schultz
Reg. No. 29,108
Tarolli, Sundheim, Covell &
Tummino LLP
1300 East Ninth Street
Suite 1700
Cleveland, OH 44114
(216) 621-2234
(216) 621-4072 Fax
sschultz@tarolli.com

2 of 2

IN THE UNITED STATES PATENT AND TRADEMARK OFFICE

In Re Patent No.: 5,796,183

Issue Date: August 18, 1998

RECEIVED

Application No.: 08/601,268

Filing Date: January 31, 1996

NOV 08 2010

Title: Capacitive Responsive Electronic Switching Circuit

OFFICE OF PETITIONS

Docket No.: 16-814

CERTIFICATE OF FACSIMILE	
I hereby certify that this paper is being faxed today to the Maintenance Fee Branch, 2051 Jamieson Ave., Suite 300, VA 22314	
On:	11-4-10
By:	<i>Carrie A. Lewis</i>
	Carrie A. Lewis

Director of the U.S. Patent and Trademark Office
Attn: Maintenance Fees
2051 Jamieson Avenue, Suite 300
Alexandria, VA 22314
571-273-6500

VERIFIED STATEMENT UNDER 1.28(c) EXPLAINING ERROR IN PAYMENT OF MAINTENANCE FEE UNDER SMALL ENTITY STATUS FOR U.S. PAT. NO. 5,796,183

Dear Sir or Madam:

This Verified Statement is made by a person having personal knowledge to explain how the error in payment occurred and when it was discovered in connection with the accompanying NOTIFICATION UNDER 37 CFR 1.27(g) OF ERROR IN PAYMENT OF SMALL ENTITY FEE FOR U.S. PAT. NO. 5,796,183, (hereinafter "the '183 patent").

Stephen J. Schultz, an attorney licensed to practice law in the state of Ohio and further licensed to practice before the United States Patent and Trademark Office (Reg. No. 29108) states that:

1. Application Serial No. 08/601,268 which matured into the '183 patent, was filed on January 31, 1996 and issued on April 18, 1998. The assignee of record of the '183 patent is UUSI, LLC as indicated in the records of the United States Patent and Trademark Office (herein, USPTO) at reel 023679 and frame 0803 based on an assignment from Nartron Corporation to UUSI, LLC dated December 17, 2009 that was recorded on December 22, 2009.

2. Upon information and belief, at all times discussed herein the total number of employees of Nartron Corporation, including all affiliates, subsidiaries and related companies under the control of Nartron Corporation was less than 500 employees and therefore, absent other facts, Nartron Corporation was entitled to payment of any fees in the USPTO for prosecution, issuance and maintenance as a small entity.

3. Upon information and belief, from December 17, 2009 to the present the total number of employees of UUSI, LLC, including all affiliates, subsidiaries and related companies under the control of UUSI, LLC was less than 500 employees and therefore, absent other facts, UUSI, LLC was entitled to payment of any fees in the USPTO for maintenance as a small entity.

4. Upon information and belief, the law firm of Price, Heneveld, Cooper et al, P.O. Box 2567, Grand Rapids, MI 4901, (herein Price, Heneveld) represented Nartron in matters before the USPTO regarding the '183 patent up to and including payment of the first (4th year) maintenance fee.

5. Upon information and belief, the first maintenance fee was paid on or about November 2, 2001 as a large entity and upon information and belief Nartron Corporation informed the USPTO that it no longer claimed small entity status in regard with the '183 patent.

6. Subsequent to the payment of the first maintenance fee the patent file maintained by the Price, Heneveld firm was transferred to me at my then current employer, Watts, Hoffmann Co. LPA along with a pending corresponding German patent application and upon information and belief, I helped Nartron Prosecute the German patent application to issuance.

7. In early February 2006, I corresponded with Mr Norman Rautiola at Nartron to inquire whether or not I should pay the second (8th year) maintenance fee and if so, should it be paid as a large or small entity.

8. In response to my inquiry, I was instructed by Mr Rautiola to pay the fee as a small entity and accordingly a claim for small entity status was mailed to the USPTO along with payment of the second maintenance fee as a small entity

in the amount of \$1,150.00. This payment is acknowledged in the records of the USPTO as being paid on or about February 21, 2006.

9. My present employer, the law firm of Tarolli, Sundheim, Covell & Tummino LLP, utilizes Computer Patent Annuity Services, Inc. of Rockville, Maryland (hereinafter "CPI") for payment of certain fees and annuities, including U.S. patent maintenance fees.

10. In February, 2010 a third maintenance fee in the amount of \$2055.00 was paid by CPI under small entity status. This payment is acknowledged in the records of the USPTO as being paid on or about February 18th, 2010.

11. On October 29, 2010 I was informed by Mr Robert Tuttle of the firm of Brooks & Kushman, 1000 Town Center, Twenty-Second Floor, Southfield, MI, 48075, that as early as January 2005, the '183 patent had been licensed by Nartron Corporation in a confidential litigation settlement agreement to an entity that qualifies as a large entity under 37 CFR 1.27 and that therefore the second (8th year) maintenance fee should have been paid as a large entity on behalf of Nartron and that the third (12th year) maintenance fee should have been paid as a large entity on behalf of UUSI, LLC. Upon information and belief, when instructing me to pay the second maintenance fee as a small entity, Mr Rautiola

was not mindful of either a) the existence of the license or b) the effect this litigation settlement had on Nartron's status as a small entity for the '183 patent.

12. The following is an itemization of the payment made and the deficiency owed for the '183 patent according to the now current USPTO fee schedule (37 CFR 1.20(f & g)), resulting from the change to large entity status:

<u>Date</u>	<u>Description</u>	<u>Paid</u>	<u>Actually Owed</u>
February 21, 2006	8th Yr Maintenance Fee	\$1150	\$2480
February 18, 2010	12 th Yr Maintenance Fee	\$2055	\$4110

Total deficiency owed: \$ 3385.

13. Any error in paying the above listed fees as a small entity was without deceptive or fraudulent intent and was inadvertent.

14. I hereby declare that all statements made herein of my own knowledge are true and that all statements made on information and belief are believed to be true; further that these statements were made with the knowledge that willful false statements and the like so made are punishable by fine or imprisonment, or both under Section 1001 of Title 18 of the United States Code and that such willful false statements may jeopardize the validity of the '183 patent.

Date: Nov 4, 2010



Stephen J. Schultz
Reg. No. 29,108
Tarolli, Sundheim, Covell &
Tummino LLP
1300 East Ninth Street
Suite 1700
Cleveland, OH 44114
(216) 621-2234
(216) 621-4072 Fax
sschultz@tarolli.com

AO 120 (Rev. 3/2004)

Mail Stop 8 TO: Director of the U.S. Patent and Trademark Office P.O. Box 1450 Alexandria, VA 22313-1450	REPORT ON THE FILING OR DETERMINATION OF AN ACTION REGARDING A PATENT OR TRADEMARK
---	--

In Compliance with 35 § 290 and/or 15 U.S.C. § 1116 you are hereby advised that a court action has been filed in the U.S. District Court Western District of Michigan on the following Patents or Trademarks:

DOCKET NO. 1:10-cv-691	DATE FILED 07/20/2010	U.S. DISTRICT COURT Western District of Michigan - at Grand Rapids
PLAINTIFF NARTRON CORPORATION et al.		DEFENDANT BYRON HOURMAND
PATENT OR TRADEMARK NO.	DATE OF PATENT OR TRADEMARK	HOLDER OF PATENT OR TRADEMARK
1 5,796,183	08/18/1998	Natron Corporation
2		
3		
4		
5		

In the above—entitled case, the following patent(s) have been included:

DATE INCLUDED	INCLUDED BY <input type="checkbox"/> Amendment <input type="checkbox"/> Answer <input type="checkbox"/> Cross Bill <input type="checkbox"/> Other Pleading		
PATENT OR TRADEMARK NO.	DATE OF PATENT OR TRADEMARK	HOLDER OF PATENT OR TRADEMARK	
1			
2			
3			
4			
5			

In the above—entitled case, the following decision has been rendered or judgment issued:

DECISION/JUDGMENT See attached Consent Judgment entered 9/8/10

CLERK TRACEY CORDES	(BY) DEPUTY CLERK By /s/ G. Frayer	DATE 9/9/10
------------------------	---------------------------------------	----------------

Best Available Copy



UNITED STATES PATENT AND TRADEMARK OFFICE

Commissioner for Patents
United States Patent and Trademark Office
P.O. Box 1450
Alexandria, VA 22313-1450
www.uspto.gov

19
10-5-05

Date : *October 9, 2010*

Patent No. : 5796183
Inventor(s) : 08/601268
Issued : August 18, 1998
Title : CAPACITIVE RESPONSIVE ELECTRONIC SWITCHING CIRCUIT

Re: Request for Certificate of Correction

Consideration has been given your request for the issuance of a certificate of correction for the above-identified patent under the provisions of Rules 1.322 and 1.323.

With respect to the alleged error concerning the addition of inventors' names; the inventors are printed in accordance with the Declaration and/or ADS submitted at the time of filing the application or the filing of a petition during pendency. Review of the application file does not reveal a petition/amendment that meet the requirement of changing the inventorship. Accordingly, correction is not warranted under 1.322 or 1.323 as filed.

In view of the foregoing, your request is hereby denied.

However, your attention is directed to 37 C.F.R. 1.324, wherein a request is being made to add or delete inventor(s), after issuance of the patent.

Any inquiry concerning this communication should be directed to Ms. A. Green at (703) 756-1541.

[Signature]
Mary Diggs, Supervisor
Decisions & Certificates
of Correction Branch
(703) 756-1580 or 703-756-1541

Brooks Kushman, P.C.
1000 Town Center, 22nd Floor
Southfield, Michigan 48075-1238

/arg



UNITED STATES PATENT AND TRADEMARK OFFICE

Commissioner for Patents
United States Patent and Trademark Office
P.O. Box 1450
Alexandria, VA 22313-1450
www.uspto.gov

Date : *October 9, 2010*

Patent No. : 5796183
Inventor(s) : 08/601268
Issued : August 18, 1998
Title : CAPACITIVE RESPONSIVE ELECTRONIC SWITCHING CIRCUIT

Re: Request for Certificate of Correction

Consideration has been given your request for the issuance of a certificate of correction for the above-identified patent under the provisions of Rules 1.322 and 1.323.

With respect to the alleged error concerning the addition of inventors' names; the inventors are printed in accordance with the Declaration and/or ADS submitted at the time of filing the application or the filing of a petition during pendency. Review of the application file does not reveal a petition/amendment that meet the requirement of changing the inventorship. Accordingly, correction is not warranted under 1.322 or 1.323 as filed.

In view of the foregoing, your request is hereby denied.

However, your attention is directed to 37 C.F.R. 1.324, wherein a request is being made to add or delete inventor(s), after issuance of the patent.

Any inquiry concerning this communication should be directed to Ms. A. Green at (703) 756-1541.

J. A. Green
Mary Diggs, Supervisor
Decisions & Certificates
of Correction Branch
(703) 756-1580 or 703-756-*1541*

Brooks Kushman, P.C.
1000 Town Center, 22nd Floor
Southfield, Michigan 48075-1238

/arg

IN THE UNITED STATES PATENT AND TRADEMARK OFFICE

In re patent of:

BRYON HOURMAND, et al.

U.S. Patent No.: 5,796,183

Issue Date: August 18, 1998

For: CAPACITIVE RESPONSIVE ELECTRONIC SWITCHING CIRCUIT

Attorney Docket No.: NAR 0227 L

REQUEST FOR "CERTIFICATE OF CORRECTION"

Attention Certificate of Correction Branch
Commissioner for Patents
U.S. Patent & Trademark Office
P.O. Box 1450
Alexandria, VA 22313-1450

Sir:

It is requested that a Certificate of Correction be issued for the above-identified patent under the provisions of 37 C.F.R. § 1.323. The corrections noted are as follows:

The inventorship of this patent is amended to add the following joint inventors:

John M. Washeleski, of Cadillac, Michigan; and

Stephen R. W. Cooper, of Fowlerville, Michigan

UNITED STATES PATENT AND TRADEMARK OFFICE
CERTIFICATE OF CORRECTION

PATENT NO. : 5,796,183
APPLICATION NO. : 601,268
ISSUE DATE : August 18, 1998
INVENTOR(S) : Byron Hourmand et al

Page 1 of 1

It is certified that an error appears or errors appear in the above-identified patent and that said Letters Patent is hereby corrected as shown below:

The inventorship of this patent is amended to add the following joint inventors:

John M. Washeleski, of Cadillac, Michigan, and

Stephen R. W. Cooper, of Fowlerville, Michigan.

MAILING ADDRESS OF SENDER:

BROOKS KUSHMAN P.C.
1000 Town Center, 22nd Floor
Southfield, Michigan 48075-1238

This collection of information is required by 37 CFR 1.322, 1.323, and 1.324. The information is required to obtain or retain a benefit by the public which is to file (and by the USPTO to process) an application. Confidentiality is governed by 35 U.S.C. 122 and 37 CFR 1.14. This collection is estimated to take 1.0 hour to complete, including gathering, preparing, and submitting the completed application form to the USPTO. Time will vary depending upon the individual case. Any comments on the amount of time you require to complete this form and/or suggestions for reducing this burden, should be sent to the Chief Information Officer, U.S. Patent & Trademark Office, U.S. Department of Commerce, P.O. Box 1450, Alexandria, VA 22313-1450. DO NOT SEND FEES OR COMPLETED FORMS TO THIS ADDRESS. SEND TO: Attention Certificate of Corrections Branch, Commissioner for Patents, P.O. Box 1450, Alexandria, VA 22313-1450.

**UNITED STATES DISTRICT COURT
WESTERN DISTRICT OF MICHIGAN**

NARTRON CORPORATION)	
and UUSI, LLC,)	
Plaintiffs,)	
)	Civil Action No. 1:10-CV-691
v.)	
)	Honorable Robert Holmes Bell
)	
BYRON HOURMAND,)	United States District Judge
)	
Defendant.)	
)	

CONSENT JUDGMENT

The parties hereto consent to the entry of a judgment, on the terms stated below, based on the following stipulation.

STIPULATION

1. Plaintiff Nartron Corporation was the owner at issuance of U.S. Patent No. 5,796,183, (“the ‘183 patent”), by assignment from defendant Byron Hourmand for good and valuable consideration.

2. Nartron has since assigned the ‘183 patent to plaintiff UUSI, LLC.

3. The ‘183 patent at issuance named Byron Hourmand as sole inventor.

4. The ‘183 patent at issuance erroneously omitted John M. Washeleski, of Cadillac, Michigan, and Stephen R. W. Cooper, of Fowlerville, Michigan, as joint inventors.

5. John M. Washeleski and Stephen R. W. Cooper are joint inventors of the matter of independent claims 20, 21 and 27 (and claims dependent therefrom) of the ‘183 patent, as proved by the pleaded matter in the Complaint, including exhibits thereto.

6. John M. Washeleski and Stephen R. W. Cooper have stated that they are joint inventors and their omission was without deceptive intention. (Complaint Exhibits J and K.)

7. John M. Washeleski and Stephen R. W. Cooper have assigned their interests as inventors of the ‘183 patent to plaintiff Nartron Corporation. (Complaint Exhibits H and I.)

8. Byron Hourmand agrees the error in omitting John M. Washeleski and Stephen R. W. Cooper as joint inventors of the ‘183 patent was without deceptive intention.

9. Each party has read this agreement and had the assistance of counsel.

JUDGMENT

A. The Court has jurisdiction over the subject matter of and the parties to this action.

B. John M. Washeleski and Stephen R. W. Cooper were erroneously omitted as joint inventors of U.S. Patent No. 5,796,183, (“the ‘183 patent”), and such error occurred without deceptive intention.

C. Under authority of 35 U.S.C. §256,¶2, the Court orders the Director of Patents and Trademarks to issue a certificate of correction adding John M. Washeleski, of Cadillac, Michigan, and Stephen R. W. Cooper, of Fowlerville, Michigan, as joint inventors of U.S. Patent No. 5,796,183.

D. Byron Hourmand, as assignor of the ‘183 patent for good and valuable consideration, is subject to the patent law doctrine of assignor estoppel from contesting the ownership, validity and enforceability of the ‘183 patent.

E. Defendant Byron Hourmand is therefore enjoined from contesting the ownership, validity or enforceability of U.S. Patent 5,796,183, along with persons in active concert or participation with Byron Hourmand, who receive actual notice by personal service or otherwise.

F. The parties shall bear their own attorney fees and costs.

IT IS SO ORDERED.

Dated: September 8, 2010

/s/ Robert Holmes Bell
HONORABLE ROBERT HOLMES BELL
United States District Judge

AGREED:

NARTRON CORPORATION



By: Norman A. Rautiola

Its: *PRESIDENT*

Date: August 26, 2010



Byron Hourmand

a/k/a Bahram Hourmand
a/k/a Joseph Oliver deMontfort

Date: *8/19/2010*

UUSI, LLC

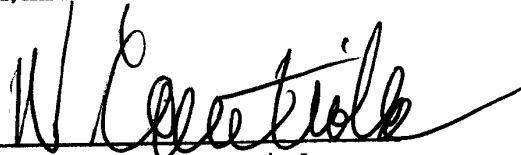

By: Norman A. Rautiola

Its: *MGR.*

Date: August 26, 2010

Electronic Patent Application Fee Transmittal

Application Number:	08601268			
Filing Date:	31-Jan-1996			
Title of Invention:	CAPACITIVE RESPONSIVE ELECTRONIC SWITCHING CIRCUIT			
First Named Inventor/Applicant Name:	BYRON HOURMAND			
Filer:	John E. Nemazi/Claire Flood			
Attorney Docket Number:	NAR01-P-310			
Filed as Large Entity				
Utility under 35 USC 111(a) Filing Fees				
Description	Fee Code	Quantity	Amount	Sub-Total in USD(\$)
Basic Filing:				
Pages:				
Claims:				
Miscellaneous-Filing:				
Petition:				
Patent-Appeals-and-Interference:				
Post-Allowance-and-Post-Issuance:				
Certificate of correction	1811	1	100	100
Extension-of-Time:				

Description	Fee Code	Quantity	Amount	Sub-Total in USD(\$)
Miscellaneous:				
Total in USD (\$)				100

Electronic Acknowledgement Receipt

EFS ID:	8414033
Application Number:	08601268
International Application Number:	
Confirmation Number:	3176
Title of Invention:	CAPACITIVE RESPONSIVE ELECTRONIC SWITCHING CIRCUIT
First Named Inventor/Applicant Name:	BYRON HOURMAND
Correspondence Address:	PRICE HENEVELD COOPER DEWITT & LITTON 695 KENMOOR DRIVE SE P O BOX 2567 GRAND RAPIDS MI 49501 US - -
Filer:	John E. Nemazi/Claire Flood
Filer Authorized By:	John E. Nemazi
Attorney Docket Number:	NAR01-P-310
Receipt Date:	14-SEP-2010
Filing Date:	31-JAN-1996
Time Stamp:	15:28:26
Application Type:	Utility under 35 USC 111(a)

Payment information:

Submitted with Payment	yes
Payment Type	Deposit Account
Payment was successfully received in RAM	\$100

RAM confirmation Number	1717				
Deposit Account	023978				
Authorized User					
The Director of the USPTO is hereby authorized to charge indicated fees and credit any overpayment as follows: Charge any Additional Fees required under 37 C.F.R. Section 1.17 (Patent application and reexamination processing fees)					
File Listing:					
Document Number	Document Description	File Name	File Size(Bytes)/ Message Digest	Multi Part /.zip	Pages (if appl.)
1	Request for Certificate of Correction	Request.pdf	131207	no	7
			7e3a1621dfbe19f502fe0fc9e4fb9e81e0f206d		
Warnings:					
Information:					
2	Fee Worksheet (PTO-875)	fee-info.pdf	30214	no	2
			06d5cfeacdf6ad32529b3c6e3e88ce83d730209		
Warnings:					
Information:					
Total Files Size (in bytes):			161421		
<p>This Acknowledgement Receipt evidences receipt on the noted date by the USPTO of the indicated documents, characterized by the applicant, and including page counts, where applicable. It serves as evidence of receipt similar to a Post Card, as described in MPEP 503.</p> <p><u>New Applications Under 35 U.S.C. 111</u> If a new application is being filed and the application includes the necessary components for a filing date (see 37 CFR 1.53(b)-(d) and MPEP 506), a Filing Receipt (37 CFR 1.54) will be issued in due course and the date shown on this Acknowledgement Receipt will establish the filing date of the application.</p> <p><u>National Stage of an International Application under 35 U.S.C. 371</u> If a timely submission to enter the national stage of an international application is compliant with the conditions of 35 U.S.C. 371 and other applicable requirements a Form PCT/DO/EO/903 indicating acceptance of the application as a national stage submission under 35 U.S.C. 371 will be issued in addition to the Filing Receipt, in due course.</p> <p><u>New International Application Filed with the USPTO as a Receiving Office</u> If a new international application is being filed and the international application includes the necessary components for an international filing date (see PCT Article 11 and MPEP 1810), a Notification of the International Application Number and of the International Filing Date (Form PCT/RO/105) will be issued in due course, subject to prescriptions concerning national security, and the date shown on this Acknowledgement Receipt will establish the international filing date of the application.</p>					

IN THE UNITED STATES PATENT AND TRADEMARK OFFICE

Wait File #18
PSW
ALG
9/14/10

In re patent of:

BRYON HOURMAND, et al.

U.S. Patent No.: 5,796,183

Issue Date: August 18, 1998

For: CAPACITIVE RESPONSIVE ELECTRONIC SWITCHING CIRCUIT

Attorney Docket No.: NAR 0227 L

REQUEST FOR "CERTIFICATE OF CORRECTION"

Attention Certificate of Correction Branch
Commissioner for Patents
U.S. Patent & Trademark Office
P.O. Box 1450
Alexandria, VA 22313-1450

Sir:

It is requested that a Certificate of Correction be issued for the above-identified patent under the provisions of 37 C.F.R. § 1.323. The corrections noted are as follows:

The inventorship of this patent is amended to add the following joint inventors:

John M. Washeleski, of Cadillac, Michigan; and

Stephen R. W. Cooper, of Fowlerville, Michigan

**UNITED STATES PATENT AND TRADEMARK OFFICE
CERTIFICATE OF CORRECTION**

PATENT NO. : 5,796,183
APPLICATION NO. : 601,268
ISSUE DATE : August 18, 1998
INVENTOR(S) : Byron Hourmand et al

Page 1 of 1

It is certified that an error appears or errors appear in the above-identified patent and that said Letters Patent is hereby corrected as shown below:

The inventorship of this patent is amended to add the following joint inventors:

John M. Washeleski, of Cadillac, Michigan, and

Stephen R. W. Cooper, of Fowlerville, Michigan.

MAILING ADDRESS OF SENDER:

BROOKS KUSHMAN P.C.
1000 Town Center, 22nd Floor
Southfield, Michigan 48075-1238

This collection of information is required by 37 CFR 1.322, 1.323, and 1.324. The information is required to obtain or retain a benefit by the public which is to file (and by the USPTO to process) an application. Confidentiality is governed by 35 U.S.C. 122 and 37 CFR 1.14. This collection is estimated to take 1.0 hour to complete, including gathering, preparing, and submitting the completed application form to the USPTO. Time will vary depending upon the individual case. Any comments on the amount of time you require to complete this form and/or suggestions for reducing this burden, should be sent to the Chief Information Officer, U.S. Patent & Trademark Office, U.S. Department of Commerce, P.O. Box 1450, Alexandria, VA 22313-1450. DO NOT SEND FEES OR COMPLETED FORMS TO THIS ADDRESS. SEND TO: Attention Certificate of Corrections Branch, Commissioner for Patents, P.O. Box 1450, Alexandria, VA 22313-1450.

The parties hereto consent to the entry of a judgment, on the terms stated below, based on the following stipulation.

STIPULATION

1. Plaintiff Nartron Corporation was the owner at issuance of U.S. Patent No. 5,796,183, ("the '183 patent"), by assignment from defendant Byron Hourmand for good and valuable consideration.

2. Nartron has since assigned the '183 patent to plaintiff UUSI, LLC.

3. The '183 patent at issuance named Byron Hourmand as sole inventor.

4. The '183 patent at issuance erroneously omitted John M. Washeleski, of Cadillac, Michigan, and Stephen R. W. Cooper, of Fowlerville, Michigan, as joint inventors.

5. John M. Washeleski and Stephen R. W. Cooper are joint inventors of the matter of independent claims 20, 21 and 27 (and claims dependent therefrom) of the '183 patent, as proved by the pleaded matter in the Complaint, including exhibits thereto.

6. John M. Washeleski and Stephen R. W. Cooper have stated that they are joint inventors and their omission was without deceptive intention. (Complaint Exhibits J and K.)

7. John M. Washeleski and Stephen R. W. Cooper have assigned their interests as inventors of the '183 patent to plaintiff Nartron Corporation. (Complaint Exhibits H and I.)

8. Byron Hourmand agrees the error in omitting John M. Washeleski and Stephen R. W. Cooper as joint inventors of the '183 patent was without deceptive intention.

9. Each party has read this agreement and had the assistance of counsel.

JUDGMENT

A. The Court has jurisdiction over the subject matter of and the parties to this action.

B. John M. Washeleski and Stephen R. W. Cooper were erroneously omitted as joint inventors of U.S. Patent No. 5,796,183, ("the '183 patent"), and such error occurred without deceptive intention.

C. Under authority of 35 U.S.C. §256,¶2, the Court orders the Director of Patents and Trademarks to issue a certificate of correction adding John M. Washeleski, of Cadillac, Michigan, and Stephen R. W. Cooper, of Fowlerville, Michigan, as joint inventors of U.S. Patent No. 5,796,183.

D. Byron Hourmand, as assignor of the '183 patent for good and valuable consideration, is subject to the patent law doctrine of assignor estoppel from contesting the ownership, validity and enforceability of the '183 patent.

E. Defendant Byron Hourmand is therefore enjoined from contesting the ownership, validity or enforceability of U.S. Patent 5,796,183, along with persons in active concert or participation with Byron Hourmand, who receive actual notice by personal service or otherwise.

F. The parties shall bear their own attorney fees and costs.

IT IS SO ORDERED.

Dated: September 8, 2010

/s/ Robert Holmes Bell
HONORABLE ROBERT HOLMES BELL
United States District Judge

AGREED:

NARTRON CORPORATION



By: Norman A. Rautiola

Its: *PRESIDENT*

Date: August 26, 2010



Byron Hourmand

a/k/a Bahram Hourmand
a/k/a Joseph Oliver deMontfort

Date: *8/19/2010*

UUSI, LLC

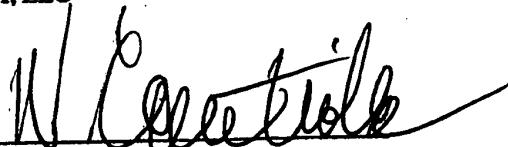

By: Norman A. Rautiola

Its: *MOR.*

Date: August 26, 2010

AO 120 (Rev. 3/2004)

Mail Stop 8 TO: Director of the U.S. Patent and Trademark Office P.O. Box 1450 Alexandria, VA 22313-1450	REPORT ON THE FILING OR DETERMINATION OF AN ACTION REGARDING A PATENT OR TRADEMARK
---	--

In Compliance with 35 § 290 and/or 15 U.S.C. § 1116 you are hereby advised that a court action has been filed in the U.S. District Court Western District of Michigan on the following Patents or Trademarks:

DOCKET NO. 1:10-cv-691	DATE FILED 07/20/2010	U.S. DISTRICT COURT Western District of Michigan - at Grand Rapids
PLAINTIFF NARTRON CORPORATION et al.		DEFENDANT BYRON HOURMAND
PATENT OR TRADEMARK NO.	DATE OF PATENT OR TRADEMARK	HOLDER OF PATENT OR TRADEMARK
1 5,796,183	08/18/1998	Natron Corporation
2		
3		
4		
5		

In the above—entitled case, the following patent(s) have been included:

DATE INCLUDED	INCLUDED BY <input type="checkbox"/> Amendment <input type="checkbox"/> Answer <input type="checkbox"/> Cross Bill <input type="checkbox"/> Other Pleading		
PATENT OR TRADEMARK NO.	DATE OF PATENT OR TRADEMARK	HOLDER OF PATENT OR TRADEMARK	
1			
2			
3			
4			
5			

In the above—entitled case, the following decision has been rendered or judgment issued:

DECISION/JUDGMENT See attached Consent Judgment entered 9/8/10

CLERK TRACEY CORDES	(BY) DEPUTY CLERK By /s/ G. Frayer	DATE 9/9/10
------------------------	---------------------------------------	----------------

AO 120 (Rev. 3/2004)

Mail Stop 8 TO: Director of the U.S. Patent and Trademark Office P.O. Box 1450 Alexandria, VA 22313-1450	REPORT ON THE FILING OR DETERMINATION OF AN ACTION REGARDING A PATENT OR TRADEMARK
---	--

In Compliance with 35 § 290 and/or 15 U.S.C. § 1116 you are hereby advised that a court action has been filed in the U.S. District Court Western District of Michigan on the following Patents or Trademarks:

DOCKET NO. 1:10-cv-691	DATE FILED 07/20/2010	U.S. DISTRICT COURT Western District of Michigan - at Grand Rapids
PLAINTIFF NARTRON CORPORATION et al.		DEFENDANT BYRON HOURMAND
PATENT OR TRADEMARK NO.	DATE OF PATENT OR TRADEMARK	HOLDER OF PATENT OR TRADEMARK
1 5,796,183	08/18/1998	Nartron Corporation
2		
3		
4		
5		

In the above—entitled case, the following patent(s) have been included:

DATE INCLUDED	INCLUDED BY	
	<input type="checkbox"/> Amendment <input type="checkbox"/> Answer <input type="checkbox"/> Cross Bill <input type="checkbox"/> Other Pleading	
PATENT OR TRADEMARK NO.	DATE OF PATENT OR TRADEMARK	HOLDER OF PATENT OR TRADEMARK
1		
2		
3		
4		
5		

In the above—entitled case, the following decision has been rendered or judgment issued:

DECISION/JUDGMENT

CLERK TRACEY CORDES	(BY) DEPUTY CLERK By /s/ R. Wolters	DATE 07/21/2010
------------------------	--	--------------------

-Continued on Page 2-

SPE RESPONSE FOR CERTIFICATE OF CORRECTION

Paper No.: _____

DATE : 01-03-10

TO SPE OF : ART UNIT 2836

SUBJECT : Request for Certificate of Correction for Appl. No.: 08/601268 Patent No.: 5796183

CofC mailroom date: 12-06-10

Please respond to this request for a certificate of correction within 7 days.

FOR IFW FILES:

Please review the requested changes/corrections as shown in the **COCIN** document(s) in the IFW application image. No new matter should be introduced, nor should the scope or meaning of the claims be changed.

Please complete the response (see below) and forward the completed response to scanning using document code **COCX**.

FOR PAPER FILES:

Please review the requested changes/corrections as shown in the attached certificate of correction. Please complete this form (see below) and forward it with the file to:

Certificates of Correction Branch (CofC)
Randolph Square - 9D10-A
Palm Location 7580



Certificates of Correction Branch
Angela Green

Thank You For Your Assistance

The request for issuing the above-identified correction(s) is hereby:

Note your decision on the appropriate box.

- | | |
|---|---|
| <input type="checkbox"/> Approved | All changes apply. |
| <input type="checkbox"/> Approved in Part | Specify below which changes do not apply. |
| <input type="checkbox"/> Denied | State the reasons for denial below. |

Comments: _____

SPE **Art Unit**

HBG, STANDARD

**U.S. District Court
United States District Court for the Middle District of Pennsylvania (Harrisburg)
CIVIL DOCKET FOR CASE #: 1:06-cv-01777-SHR SOLICITOR
Internal Use Only**

MAY 15 2007

QRG, Ltd., a/k/a Quantum Research Group, Ltd. v.
NARTRON CORPORATION
Assigned to: Honorable Sylvia H. Rambo
Case in other court: U.S. District Court, Western District of
PA, 2:06-CV-500
Cause: 28:2201 Declaratory Judgement

Date Filed: 09/12/2006
Jury Demand: Both
Nature of Suit: 830 Patent
Jurisdiction: Federal Question

U.S. PATENT & TRADEMARK OFFICE

Plaintiff

QRG, LTD.
a/k/a Quantum Research Group, Ltd.

represented by **Andrew E. Falsetti**
Reed Smith LLP
435 Sixth Avenue
Pittsburgh, PA 15219
412-288-3844
Email: afalsetti@reedsmith.com
LEAD ATTORNEY
ATTORNEY TO BE NOTICED

Pat. # 4,731,548
4,758,735
5,796,183
4,831,279
5,087,825

Gene A. Tabachnick
Reed Smith LLP
435 Sixth Avenue
Pittsburgh, PA 15219
412-288-3258
Email: gtabachnick@reedsmith.com
LEAD ATTORNEY
ATTORNEY TO BE NOTICED

Robert B. Hoffman
Wolf Block
213 Market Street, 9th Floor
Harrisburg, PA 17101
(717) 237-7182
Email: rhoffman@wolfblock.com
LEAD ATTORNEY
ATTORNEY TO BE NOTICED

V.

Defendant

NARTRON CORPORATION

represented by **Mark D. Chuey**
Brooks Kushman P.C.
1000 Town Center

3. Defendant Nartron is located at 5000 North US-131, Reed City, Michigan. Upon information and belief, Defendant is doing business, has carried out substantial business, and has had other substantial contacts within this judicial district.

4. This Court has jurisdiction over the subject matter of this action under the provisions of 28 U.S.C. §§ 1331, 1332(a)(2), 1338(a), 2201 and 2202, and venue is proper under 28 U.S.C. §§ 1391(b) and (c).

COUNT I – DECLARATORY JUDGMENT

5. Defendant claims to be the owner of United States Letters Patent Nos. 4,731,548 (“the ‘548 Patent”), 4,758,735 (“the ‘735 Patent”), 5,796,183 (“the ‘183 Patent”), 4,831,279 (“the ‘279 Patent”), and 5,087,825 (“the ‘825 Patent”), hereinafter referred to collectively as “the Patents.”

6. Defendant and its primary shareholder, Norman Rautiola, have a reputation for being litigious, and aggressively pursuing even dubious infringement claims.

7. Defendant has repeatedly threatened Plaintiff, both in writing and orally, with patent infringement. Defendant, for example, wrote that Plaintiff’s Form QProx product “is obviously an infringement of our patented technology” and declared that “[w]e intend to pursue this claim of infringement and suggest that you immediately contact our attorney”

8. Defendant’s litigious nature was not diminished by its filing for Chapter 11 bankruptcy. Defendant petitioned the bankruptcy court so Nartron could employ a law firm to prosecute patent infringement actions on a contingency fee basis during its reorganization.

9. Defendant's eventual emergence from bankruptcy enabled Nartron to continue its string of infringement suits, and upon information and belief, Defendant is currently engaged in at least two other patent litigations.

10. Despite Defendant's threats to the contrary, Plaintiff has not infringed any valid claim of the Patents as properly construed.

11. Furthermore, by virtue of the proceedings in the United States Patent and Trademark Office during prosecution of the Patents, and by virtue of the admissions, representations and concessions made by or on behalf of the named inventors and their representatives, Defendant is estopped from construing any claims of the Patents to cover any product made, used, sold, or offered for sale by Plaintiff.

12. Plaintiff further alleges that each of the claims of the Patents is invalid and/or unenforceable and of no legal effect against Plaintiff for failure to comply with the Patent Statute including, but not limited to, 35 U.S.C. §§ 102, 103 and 112 and/or because the alleged inventors and owner of the Patent and/or their attorneys failed to properly discharge their duty of candor and good faith in their dealings with the United States Patent and Trademark Office.

13. By reason of the foregoing, an actual controversy between Plaintiff and Defendant exists as to the alleged infringement, validity, and enforceability of the Patents.

WHEREFORE, Plaintiff prays for the following relief:

1. That the Court enter judgment declaring that Plaintiff's capacitive touch sensor products have not and do not infringe any valid and enforceable claim of United States Letters Patent Nos. 4,731,548, 4,758,735, 5,796,183, 4,831,279, and 5,087,825;
2. That the Court declare that the claims of United States Letters Patent Nos. 4,731,548, 4,758,735, 5,796,183, 4,831,279, and 5,087,825 are invalid and the Patents unenforceable;
3. That the Court enter judgment declaring this case to be exceptional pursuant to 35 U.S.C. § 285; and
4. That the Court award to Plaintiff counsel fees, costs, and all other relief that the Court deems appropriate.

DATED: April 13, 2006

/s/ Andrew E. Falsetti

Gene A. Tabachnick
PA I.D. # 73032
Frederick H. Colen
PA I.D. # 21833
Andrew E. Falsetti
PA I.D. # 90856

REED SMITH LLP
435 Sixth Avenue
Pittsburgh, PA 15219
(412) 288-3258/4164/3844

Counsel for Plaintiff
QRG, Ltd.

IN THE UNITED STATES DISTRICT COURT
FOR THE WESTERN DISTRICT OF PENNSYLVANIA

QRG, LTD.,)	
)	
Plaintiff,)	Civil Action No. _____
)	
vs.)	
)	
NARTRON CORPORATION,)	
)	
Defendant.)	

DEMAND FOR JURY TRIAL

Pursuant to Rule 38 of the Federal Rules of Civil Procedure, Plaintiff hereby demands a jury trial for all issues properly triable before a jury.

DATED: April 13, 2006

/s/ Andrew E. Falsetti
 Gene A. Tabachnick
 PA LD. # 73032
 Frederick H. Colen
 PA LD. # 21833
 Andrew E. Falsetti
 PA LD. # 90856

REED SMITH LLP
 435 Sixth Avenue
 Pittsburgh, PA 15219
 (412) 288-3258/4164/3844

Counsel for Plaintiff
 QRG, Ltd.

22nd Floor
Southfield, MI 48075-1238
248-358-4400
Email: mchuey@brookskushman.com
LEAD ATTORNEY
ATTORNEY TO BE NOTICED

Mark A. Grace
Cohen & Grigsby PC
11 Stanwix Street
15th Floor
Pittsburgh, PA 15222-1319
412-297-4900
Email: mgrace@cohenlaw.com
LEAD ATTORNEY
ATTORNEY TO BE NOTICED

Robert C.J. Tuttle
Brooks Kushman P.C.
1000 Town Center
22nd Floor
Southfield, MI 48075-1238
248-358-4400
Email: rtuttle@brookskushman.com
LEAD ATTORNEY
ATTORNEY TO BE NOTICED

Thomas C. Wettach
Cohen & Grigsby, PC
11 Stanwix Street
15th Floor
Pittsburgh, PA 15222
412-297-4900
Email: twettach@cohenlaw.com
LEAD ATTORNEY
ATTORNEY TO BE NOTICED

Jill L. Bradley
Cohen & Grigsby, P.C.
11 Stanwix Street, 15th Floor
Pittsburgh, PA 15222
412-297-4707
Email: jbradley@cohenlaw.com
ATTORNEY TO BE NOTICED

Counterclaim Plaintiff

NARTRON CORPORATION

represented by **Mark D. Chuey**
(See above for address)
LEAD ATTORNEY
ATTORNEY TO BE NOTICED

Mark A. Grace
 (See above for address)
LEAD ATTORNEY
ATTORNEY TO BE NOTICED

Robert C.J. Tuttle
 (See above for address)
LEAD ATTORNEY
ATTORNEY TO BE NOTICED

Thomas C. Wettach
 (See above for address)
LEAD ATTORNEY
ATTORNEY TO BE NOTICED

Jill L. Bradley
 (See above for address)
ATTORNEY TO BE NOTICED

V.
Counterclaim Defendant
QRG, LTD.

represented by **Andrew E. Falsetti**
 (See above for address)
LEAD ATTORNEY
ATTORNEY TO BE NOTICED

Gene A. Tabachnick
 (See above for address)
LEAD ATTORNEY
ATTORNEY TO BE NOTICED

Robert B. Hoffman
 Wolf Block Schorr and Solis-Cohen,
 LLP
 213 Market Street, 9th Floor
 Harrisburg, PA 17101
 (717) 237-7182
 Email: rhoffman@wolfblock.com
LEAD ATTORNEY
ATTORNEY TO BE NOTICED

Date Filed	#	Docket Text
09/12/2006	<p>1</p>	<p>Case transferred in from District of Western District of Pennsylvania; Case Number 2:06-CV-500. Original file with documents numbered 1-17, certified copy of transfer order and docket sheet received., filed by QRG, LTD.. (Attachments: # 1 Civil Cover Sheet # 2 Receipt# 3 Doc. 2-</p>

		<p>Disclosure Statement# <u>4</u> Doc. 3- Summons# <u>5</u> Doc. 4- Motion to Dismiss# <u>6</u> Proposed Order to Motion to Dismiss# <u>7</u> Doc. 5- Brief in Support to Motion to Dismiss# <u>8</u> Exhibit A# <u>9</u> Exhibit B# <u>10</u> Exhibit C# <u>11</u> Doc. 6- Notice of Appearance by Thomas C. Wettach# <u>12</u> Doc. 7- Notice; Response to Motion to Dismiss# <u>13</u> Doc. 8- Motion for Discovery# <u>14</u> Proposed Order for Motion for Discovery# <u>15</u> Exhibit 1# <u>16</u> Exhibit 2# <u>17</u> Exhibit 3# <u>18</u> Exhibit 4# <u>19</u> Exhibit 6# <u>20</u> Exhibit 7# <u>21</u> Exhibit 8# <u>22</u> Exhibit 9# <u>23</u> Exhibit 5 (Motion for Discovery)# <u>24</u> Doc. 9- Notice:Response to Motion for Discovery# <u>25</u> Doc. 10- Brief in Opp. to Motion for Discovery# <u>26</u> Exhibit A (Brief in Opp. to Discovery)# <u>27</u> Exhibit B (Brief in Opp. to Discovery)# <u>28</u> Exhibit C (Brief in Opp. for Discovery)# <u>29</u> Exhibit D- (Brief in Opp. to Discovery)# <u>30</u> Doc. 11- Order Granting Motion for Discovery# <u>31</u> Doc. 12- Brief in Opp. to Motion to Dismiss# <u>32</u> Exhibit A (Brief in Opp. to Motion to Dismiss)# <u>33</u> Exhibit B (Brief in Opp. to Motion to Dismiss)# <u>34</u> Exhibit C (Brief in Opp. to Motion to Dismiss)# <u>35</u> Declaration of Richard T. Ting# <u>36</u> Declaration of Andrew E. Falsetti# <u>37</u> Declaration of Harald Philipp# <u>38</u> Declaration of Chris Bede# <u>39</u> Doc. 3 - Motion for Leave to File a Brief in Reply# <u>40</u> Exhibit A (Motion to File Brief in Reply)# <u>41</u> Doc. 14- Response to Motion for Leave to File a Brief in Reply# <u>42</u> Supplemental Declaration of Richard Ting# <u>43</u> Doc. 15-Order Granting Motion to File Brief in Reply# <u>44</u> Doc. 16- Brief in Reply# <u>45</u> Exhibit A (Brief in Reply)# <u>46</u> Doc. 17- Order Denying Motion to Dismiss. ADDITIONAL ATTACHMENTS ADDED-TRANSFER LETTER AND DOCKET FROM WESTERN DISTRICT OF PA(s) added on 9/13/2006 (crh,). (Entered: 09/13/2006)</p>
09/13/2006	<u>1</u>	SPECIAL ADMISSION FORM SENT to Andrew E. Falsetti, Mark A. Grace & Thomas C. Wettach (crh,) (Entered: 09/13/2006)
09/13/2006	<u>2</u>	Transfer Letter to Counsel (crh,) (Entered: 09/13/2006)
09/20/2006	<u>3</u>	NOTICE:A Case Mgmnt Conf has been set for 10/24/2006 @ 9:15 AM before Honorable Sylvia H. Rambo. This conference is by phone and the call is to initiated by the pltf. unless otherwise agreed upon. A joint case mgmnt plan is to be filed n/l/t 10/17/06.(ma,) (Entered: 09/20/2006)
09/21/2006	<u>4</u>	PETITION FOR SPECIAL ADMISSION (PRO HAC VICE) by Andrew E. Falsetti on behalf of QRG, LTD. Attorney Andrew E. Falsetti is seeking special admission. Filing Fee: 25.00 Receipt Number: 111 146455 (Attachments: # <u>1</u> Receipt) (jc) (Entered: 09/21/2006)
09/21/2006	<u>5</u>	PETITION FOR SPECIAL ADMISSION (PRO HAC VICE) by Gene A. Tabachnick on behalf of QRG, LTD. Attorney Gene A. Tabachnick is seeking special admission. Filing Fee: 25.00 Receipt Number: 111 146455 (Attachments: # <u>1</u> Receipt) (jc) (Entered: 09/21/2006)
09/21/2006	<u>6</u>	NOTICE of Appearance by Robert B. Hoffman on behalf of QRG, LTD. (Hoffman, Robert) (Entered: 09/21/2006)
09/22/2006	<u>7</u>	SPECIAL ADMISSIONS FORM APPROVED as to Andrew Falsetti, Esq. on behalf of ORG, LTDSigned by Judge Sylvia H. Rambo on

		09/22/06. (ma,) (Entered: 09/22/2006)
09/22/2006	8	SPECIAL ADMISSIONS FORM APPROVED as to Gene Tabachnick, Esq. on behalf of QRG, LTD Signed by Judge Sylvia H. Rambo on 09/22/06. (ma,) (Entered: 09/22/2006)
09/29/2006	9	PETITION FOR SPECIAL ADMISSION (PRO HAC VICE) by Mark D. Chuey on behalf of NARTRON CORPORATION Attorney Mark D. Chuey is seeking special admission. Filing Fee: 25.00 Receipt Number: 111 146486 (crh,) (Entered: 09/29/2006)
09/29/2006	10	PETITION FOR SPECIAL ADMISSION (PRO HAC VICE) by Robert C.J. Tuttle on behalf of NARTRON CORPORATION Attorney Robert C.J. Tuttle is seeking special admission. Filing Fee: 25.00 Receipt Number: 111 146485. (crh,) (Entered: 09/29/2006)
10/02/2006	11	SPECIAL ADMISSIONS FORM APPROVED as to Mark D. Chuey, Esq. on behalf of Nartron/Signed by Judge Sylvia H. Rambo on 10/02/06. (ma,) (Entered: 10/02/2006)
10/02/2006	12	SPECIAL ADMISSIONS FORM APPROVED as to Robert Tuttle, Esq. on behalf of Nartron.Signed by Judge Sylvia H. Rambo on 10/02/06. (ma,) (Entered: 10/02/2006)
10/06/2006	13	ANSWER to Complaint by NARTRON CORPORATION. (Attachments: # 1 Exhibit(s) A# 2 Exhibit(s) B)(Bradley, Jill) (Entered: 10/06/2006)
10/17/2006	14	CASE MANAGEMENT PLAN by QRG, LTD.. (Falsetti, Andrew) (Entered: 10/17/2006)
10/18/2006	15	PETITION FOR SPECIAL ADMISSION (PRO HAC VICE) by Mark A. Grace on behalf of NARTRON CORPORATION Attorney Mark A. Grace is seeking special admission. Filing Fee: 25.00 Receipt Number: 111 146621. (crh,) (Entered: 10/18/2006)
10/18/2006	16	PETITION FOR SPECIAL ADMISSION (PRO HAC VICE) by Thomas C. Wettach on behalf of NARTRON CORPORATION Attorney Thomas C. Wettach is seeking special admission. Filing Fee: 25.00 Receipt Number: 111 146621. (crh,) (Entered: 10/18/2006)
10/19/2006	17	SPECIAL ADMISSIONS FORM APPROVED as to Mark Grace, Esq. on behalf of Nartron Signed by Judge Sylvia H. Rambo on 10/19/06. (ma,) (Entered: 10/19/2006)
10/19/2006	18	SPECIAL ADMISSIONS FORM APPROVED as to Thomas Wettach, Esq. on behalf of Nartron Signed by Judge Sylvia H. Rambo on 10/19/06. (ma,) (Entered: 10/19/2006)
10/24/2006	20	ORDER - STANDARD CASE MANAGEMENT TRACK Case placed on the 08/2007 trial list. Cases on this list are scheduled to begin on 9/4/2007 following all j/s's starting at 9:30 AM. A date certain may be discussed at the PTC which is set for 8/17/2007 @ 1:30 PM; Discovery due by 2/28/2007. Dispositive Mtns due by 6/20/2007. PTMs due by

		8/10/2007. See order for other ddls. Signed by Judge Sylvia H. Rambo on 10/24/06. (ma,) (Entered: 10/24/2006)
11/01/2006	● <u>21</u>	MOTION to Dismiss <i>Pursuant to Fed.R.Civ.P. 12(b)(1)</i> by NARTRON CORPORATION. (Attachments: # <u>1</u> Certificate of Compliance With Local Rule 7.1# <u>2</u> Proposed Order)(Grace, Mark) (Entered: 11/01/2006)
11/01/2006	● <u>22</u>	BRIEF IN SUPPORT re <u>21</u> MOTION to Dismiss <i>Pursuant to Fed.R.Civ.P. 12(b)(1)</i> filed by NARTRON CORPORATION. (Attachments: # <u>1</u> Declaration of John E. Nemazi# <u>2</u> Exhibit(s) A - G) (Grace, Mark) (Entered: 11/01/2006)
11/16/2006	● <u>23</u>	BRIEF IN OPPOSITION re <u>21</u> MOTION to Dismiss <i>Pursuant to Fed.R.Civ.P. 12(b)(1)</i> filed by QRG, LTD.. (Attachments: # <u>1</u> Affidavit /Declaration of Harald Philipp# <u>2</u> Exhibit(s) 1# <u>3</u> Exhibit(s) 2# <u>4</u> Exhibit(s) 3# <u>5</u> Exhibit(s) 4# <u>6</u> Exhibit(s) 5# <u>7</u> Exhibit(s) 6# <u>8</u> Exhibit(s) 7)(Falsetti, Andrew) (Entered: 11/16/2006)
11/27/2006	● <u>24</u>	REPLY BRIEF re <u>21</u> MOTION to Dismiss <i>Pursuant to Fed.R.Civ.P. 12(b)(1)</i> filed by NARTRON CORPORATION. (Attachments: # <u>1</u> Exhibit(s) 1)(Grace, Mark) (Entered: 11/27/2006)
11/30/2006	● <u>25</u>	MOTION to Clarify <i>The Case Caption</i> by QRG, LTD.. (Attachments: # <u>1</u> Certificate of Compliance with Local Rule 7.1# <u>2</u> Proposed Order) (Falsetti, Andrew) (Entered: 11/30/2006)
12/01/2006	● <u>26</u>	BRIEF IN SUPPORT re <u>25</u> MOTION to Clarify <i>The Case Caption</i> filed by QRG, LTD..(Falsetti, Andrew) (Entered: 12/01/2006)
12/01/2006	● <u>27</u>	ORDER deferring ruling on Motion to Clarify <u>25</u> pending decision on dft's mtn to dismissSigned by Judge Sylvia H. Rambo on 12/01/06 (ma,) (Entered: 12/01/2006)
02/12/2007	● <u>29</u>	NOTICE by QRG, LTD. of <i>Dismissal of Related Action</i> (Attachments: # <u>1</u> Appendix Eastern District of Michigan Order and Opinion Granting Motion to Dismiss)(Falsetti, Andrew) (Entered: 02/12/2007)
03/02/2007	● <u>30</u>	MEMORANDUM AND ORDER: Denying in part dft's mtn to dismiss <u>21</u> as follows: a) The Court will reserve ruling with regard to the "capacitivetouch sensor products and related components" issue and grant Pltf lv to amend the complaint on or before 4/2/07.b) Mtn is denied in all other respects.2) Pltf's Mtn to Clarify the Case Caption <u>25</u> is GRANTED. The Clrk shall change the case caption as to pltf to read: "QRG, Ltd., a/k/a Quantum Research Group,Ltd., Plaintiff." All future filings shall display this caption. 3) An amended cmo will follow.Signed by Judge Sylvia H. Rambo on 03/02/07 (ma,) (Entered: 03/02/2007)
03/02/2007	● <u>31</u>	AMENDED CASE MANAGEMENT ORDER: J/S and Trial continued to the 10/1/2007 list beginning at 9:30 AM before Honorable Sylvia H. Rambo. Discovery due by 3/30/2007. Dispositive Mts ddl 7/20/2007. PTMs due by 9/7/2007. PTC rescheduled for 9/14/2007 @ 10:00 AM before Honorable Sylvia H. Rambo. See order for other ddls.Signed by Judge Sylvia H. Rambo on 03/02/07. (ma,) (Entered: 03/02/2007)

03/08/2007	● <u>32</u>	AMENDED COMPLAINT against NARTRON CORPORATION, filed by QRG, LTD..(Falsetti, Andrew) (Entered: 03/08/2007)
03/19/2007	● <u>33</u>	ANSWER to Amended Complaint, COUNTERCLAIM against all defendants by NARTRON CORPORATION.(Grace, Mark) (Entered: 03/19/2007)
03/20/2007	●	Correction made to docket sheet to reflect QRG, LTD. as the Counterclaim Defendant with appropriate counsel listed as per the 3/19/07 Amended Complaint and Counterclaim <u>33</u> . (dfm) (Entered: 03/20/2007)
03/23/2007	● <u>34</u>	MOTION to Strike <i>Counterclaim</i> by QRG, LTD.. (Attachments: # <u>1</u> Exhibit(s) A# <u>2</u> Exhibit(s) B# <u>3</u> Exhibit(s) C# <u>4</u> Exhibit(s) D# <u>5</u> Brief in Support# <u>6</u> Proposed Order)(Falsetti, Andrew) (Entered: 03/23/2007)
03/26/2007	● <u>35</u>	BRIEF IN SUPPORT re <u>34</u> MOTION to Strike <i>Counterclaim</i> filed by QRG, LTD..(Falsetti, Andrew) (Entered: 03/26/2007)
03/29/2007	● <u>36</u>	REPLY BRIEF re <u>34</u> MOTION to Strike <i>Counterclaim</i> filed by NARTRON CORPORATION. (Attachments: # <u>1</u> Exhibit(s) A# <u>2</u> Exhibit(s) B# <u>3</u> Exhibit(s) C - Part 1# <u>4</u> Exhibit(s) C - Part 2# <u>5</u> Exhibit(s) D# <u>6</u> Exhibit(s) E# <u>7</u> Exhibit(s) F# <u>8</u> Exhibit(s) G# <u>9</u> Exhibit(s) H# <u>10</u> Exhibit(s) I)(Grace, Mark) (Entered: 03/29/2007)
03/29/2007	● <u>37</u>	CERTIFICATE of of Compliance by NARTRON CORPORATION re <u>36</u> Reply Brief,. (Grace, Mark) (Entered: 03/29/2007)
04/12/2007	● <u>38</u>	REPLY BRIEF re <u>34</u> MOTION to Strike <i>Counterclaim</i> filed by QRG, LTD..(Falsetti, Andrew) (Entered: 04/12/2007)
04/23/2007	● <u>39</u>	MEMORANDUM AND ORDER denying pltf's Motion to Strike <u>34</u> .Signed by Judge Sylvia H. Rambo on 04/23/07 (ma,) (Entered: 04/23/2007)
04/23/2007	● <u>40</u>	NOTICE: A scheduling Conference has been scheduled for 5/10/2007 @ 9:00 AM before Honorable Sylvia H. Rambo. This conference is by phone with the call to be initiated by the pltf.Signed by Judge Sylvia H. Rambo on 04/23/07. (ma,) (Entered: 04/23/2007)
05/07/2007	● <u>41</u>	REPLY/ ANSWER to Counterclaim for Patent Infringement by QRG, LTD..(Falsetti, Andrew) (Entered: 05/07/2007)
05/07/2007	● <u>42</u>	MOTION for Partial Summary Judgment on Plaintiff QRG's Declaratory Judgment Claim for Unenforceability of The Five Nartron Patents-In-Suit by NARTRON CORPORATION.(Grace, Mark) (Entered: 05/07/2007)
05/07/2007	● <u>43</u>	STATEMENT OF FACTS re <u>42</u> MOTION for Partial Summary Judgment on Plaintiff QRG's Declaratory Judgment Claim for Unenforceability of The Five Nartron Patents-In-Suit filed by NARTRON CORPORATION. (Attachments: # <u>1</u> Index of Exhibits# <u>2</u> Exhibit(s) A# <u>3</u> Exhibit(s) B# <u>4</u> Exhibit(s) C)(Grace, Mark) (Entered: 05/07/2007)

05/07/2007	●44	BRIEF IN SUPPORT re 42 MOTION for Partial Summary Judgment on Plaintiff QRG's Declaratory Judgment Claim for Unenforceability of The Five Nartron Patents-In-Suit filed by NARTRON CORPORATION. (Grace, Mark) (Entered: 05/07/2007)
05/07/2007	●45	EXHIBIT A to Brief in Support by NARTRON CORPORATION re 44 Brief in Support. (Grace, Mark) (Entered: 05/07/2007)
05/07/2007	●46	EXHIBIT PROPOSED ORDER by NARTRON CORPORATION re 42 MOTION for Partial Summary Judgment on Plaintiff QRG's Declaratory Judgment Claim for Unenforceability of The Five Nartron Patents-In-Suit. (Grace, Mark) (Entered: 05/07/2007)
05/07/2007	●47	MOTION for Partial Summary Judgment that the Nartron Patents-In-Suit Are Not Invalid by NARTRON CORPORATION. (Attachments: # 1 Proposed Order)(Grace, Mark) (Entered: 05/07/2007)
05/07/2007	●48	STATEMENT OF FACTS re 47 MOTION for Partial Summary Judgment that the Nartron Patents-In-Suit Are Not Invalid filed by NARTRON CORPORATION. (Attachments: # 1 Index# 2 Exhibit(s) A# 3 Exhibit(s) B# 4 Exhibit(s) C# 5 Exhibit(s) D# 6 Exhibit(s) E)(Grace, Mark) (Entered: 05/07/2007)
05/07/2007	●49	BRIEF IN SUPPORT re 47 MOTION for Partial Summary Judgment that the Nartron Patents-In-Suit Are Not Invalid filed by NARTRON CORPORATION. (Attachments: # 1 Exhibit(s) A)(Grace, Mark) (Entered: 05/07/2007)
05/08/2007	●50	CERTIFICATE of Compliance with Word-Count Limit by NARTRON CORPORATION re 44 Brief in Support. (Grace, Mark) (Entered: 05/08/2007)
05/08/2007	●51	CERTIFICATE of Compliance with Word-Count Limit by NARTRON CORPORATION re 49 Brief in Support. (Grace, Mark) (Entered: 05/08/2007)
05/08/2007	●	Pursuant to the Local Rules and ECF User Manual, all motions and briefs should be filed simultaneously with their corresponding proposed orders, exhibits and any certificates as attachments to the main documents and not as individual documents. (dfm) (Entered: 05/08/2007)

IN THE UNITED STATES DISTRICT COURT
FOR THE WESTERN DISTRICT OF PENNSYLVANIA

QRG, LTD.,)	
)	
Plaintiff,)	Civil Action No. _____
)	
vs.)	
)	
NARTRON CORPORATION,)	[JURY TRIAL DEMANDED]
)	
Defendant.)	

DECLARATORY JUDGMENT COMPLAINT

Plaintiff QRG, Ltd. ("QRG"), by its counsel Reed Smith LLP, hereby alleges the following for its Declaratory Judgment Complaint against Defendant Nartron Corporation ("Nartron"):

1. This is a civil action arising under the provisions of the Declaratory Judgment Act, 28 U.S.C. §§ 2201 *et seq.*, and the patent laws of the United States, 35 U.S.C. §§ 1 *et seq.*, to declare the rights and legal relations of the parties, an actual justifiable controversy existing between the parties with respect to Plaintiff QRG's free right to make, use, sell, and offer for sale its capacitive touch sensor products and related components which are used in a wide array of products in various industries.

2. Plaintiff is a British corporation with its U.S. office at 651 Holiday Drive, Pittsburgh, Pennsylvania.

HBG, STANDARD

**U.S. District Court
United States District Court for the Middle District of Pennsylvania (Harrisburg)
CIVIL DOCKET FOR CASE #: 1:06-cv-01777-SHR SOLICITOR
Internal Use Only**

MAY 15 2007

QRG, Ltd., a/k/a Quantum Research Group, Ltd. v.
NARTRON CORPORATION
Assigned to: Honorable Sylvia H. Rambo
Case in other court: U.S. District Court, Western District of
PA, 2:06-CV-500
Cause: 28:2201 Declaratory Judgement

Date Filed: 09/12/2006
Jury Demand: Both
Nature of Suit: 830 Patent
Jurisdiction: Federal Question

U.S. PATENT & TRADEMARK OFFICE

Plaintiff

QRG, LTD.
a/k/a Quantum Research Group, Ltd.

represented by **Andrew E. Falsetti**
Reed Smith LLP
435 Sixth Avenue
Pittsburgh, PA 15219
412-288-3844
Email: afalsetti@reedsmith.com
LEAD ATTORNEY
ATTORNEY TO BE NOTICED

Pat. # 4,731,548
4,758,735
5,796,183
4,831,279
5,087,825

Gene A. Tabachnick
Reed Smith LLP
435 Sixth Avenue
Pittsburgh, PA 15219
412-288-3258
Email: gtabachnick@reedsmith.com
LEAD ATTORNEY
ATTORNEY TO BE NOTICED

Robert B. Hoffman
Wolf Block
213 Market Street, 9th Floor
Harrisburg, PA 17101
(717) 237-7182
Email: rhoffman@wolfblock.com
LEAD ATTORNEY
ATTORNEY TO BE NOTICED

V.

Defendant

NARTRON CORPORATION

represented by **Mark D. Chuey**
Brooks Kushman P.C.
1000 Town Center

3. Defendant Nartron is located at 5000 North US-131, Reed City, Michigan. Upon information and belief, Defendant is doing business, has carried out substantial business, and has had other substantial contacts within this judicial district.

4. This Court has jurisdiction over the subject matter of this action under the provisions of 28 U.S.C. §§ 1331, 1332(a)(2), 1338(a), 2201 and 2202, and venue is proper under 28 U.S.C. §§ 1391(b) and (c).

COUNT I – DECLARATORY JUDGMENT

5. Defendant claims to be the owner of United States Letters Patent Nos. 4,731,548 (“the ‘548 Patent”), 4,758,735 (“the ‘735 Patent”), 5,796,183 (“the ‘183 Patent”), 4,831,279 (“the ‘279 Patent”), and 5,087,825 (“the ‘825 Patent”), hereinafter referred to collectively as “the Patents.”

6. Defendant and its primary shareholder, Norman Rautiola, have a reputation for being litigious, and aggressively pursuing even dubious infringement claims.

7. Defendant has repeatedly threatened Plaintiff, both in writing and orally, with patent infringement. Defendant, for example, wrote that Plaintiff’s Form QProx product “is obviously an infringement of our patented technology” and declared that “[w]e intend to pursue this claim of infringement and suggest that you immediately contact our attorney”

8. Defendant’s litigious nature was not diminished by its filing for Chapter 11 bankruptcy. Defendant petitioned the bankruptcy court so Nartron could employ a law firm to prosecute patent infringement actions on a contingency fee basis during its reorganization.

9. Defendant's eventual emergence from bankruptcy enabled Nartron to continue its string of infringement suits, and upon information and belief, Defendant is currently engaged in at least two other patent litigations.

10. Despite Defendant's threats to the contrary, Plaintiff has not infringed any valid claim of the Patents as properly construed.

11. Furthermore, by virtue of the proceedings in the United States Patent and Trademark Office during prosecution of the Patents, and by virtue of the admissions, representations and concessions made by or on behalf of the named inventors and their representatives, Defendant is estopped from construing any claims of the Patents to cover any product made, used, sold, or offered for sale by Plaintiff.

12. Plaintiff further alleges that each of the claims of the Patents is invalid and/or unenforceable and of no legal effect against Plaintiff for failure to comply with the Patent Statute including, but not limited to, 35 U.S.C. §§ 102, 103 and 112 and/or because the alleged inventors and owner of the Patent and/or their attorneys failed to properly discharge their duty of candor and good faith in their dealings with the United States Patent and Trademark Office.

13. By reason of the foregoing, an actual controversy between Plaintiff and Defendant exists as to the alleged infringement, validity, and enforceability of the Patents.

WHEREFORE, Plaintiff prays for the following relief:

1. That the Court enter judgment declaring that Plaintiff's capacitive touch sensor products have not and do not infringe any valid and enforceable claim of United States Letters Patent Nos. 4,731,548, 4,758,735, 5,796,183, 4,831,279, and 5,087,825;
2. That the Court declare that the claims of United States Letters Patent Nos. 4,731,548, 4,758,735, 5,796,183, 4,831,279, and 5,087,825 are invalid and the Patents unenforceable;
3. That the Court enter judgment declaring this case to be exceptional pursuant to 35 U.S.C. § 285; and
4. That the Court award to Plaintiff counsel fees, costs, and all other relief that the Court deems appropriate.

DATED: April 13, 2006

/s/ Andrew E. Falsetti

Gene A. Tabachnick
PA I.D. # 73032
Frederick H. Colen
PA I.D. # 21833
Andrew E. Falsetti
PA I.D. # 90856

REED SMITH LLP
435 Sixth Avenue
Pittsburgh, PA 15219
(412) 288-3258/4164/3844

Counsel for Plaintiff
QRG, Ltd.

IN THE UNITED STATES DISTRICT COURT
FOR THE WESTERN DISTRICT OF PENNSYLVANIA

QRG, LTD.,)	
)	
Plaintiff,)	Civil Action No. _____
)	
vs.)	
)	
NARTRON CORPORATION,)	
)	
Defendant.)	

DEMAND FOR JURY TRIAL

Pursuant to Rule 38 of the Federal Rules of Civil Procedure, Plaintiff hereby
demands a jury trial for all issues properly triable before a jury.

DATED: April 13, 2006

/s/ Andrew E. Falsetti
 Gene A. Tabachnick
 PA LD. # 73032
 Frederick H. Colen
 PA LD. # 21833
 Andrew E. Falsetti
 PA LD. # 90856

REED SMITH LLP
 435 Sixth Avenue
 Pittsburgh, PA 15219
 (412) 288-3258/4164/3844

Counsel for Plaintiff
 QRG, Ltd.



SOLICITOR

MAY 15 2007

ATYADM, HBG

U.S. PATENT & TRADEMARK OFFICE

U.S. District Court

United States District Court for the Middle District of Pennsylvania (Harrisburg)

CIVIL DOCKET FOR CASE #: 1:07-cv-00483-YK

Internal Use Only

The Hershey Company et al v. Vermont Nut Free Chocolates Company, Inc.
Assigned to: Honorable Yvette Kane
Cause: 15:1051 Trademark Infringement

Date Filed: 03/14/2007
Jury Demand: Plaintiff
Nature of Suit: 840 Trademark
Jurisdiction: Federal Question

Plaintiff

The Hershey Company

represented by **Harvey Freedenberg**
McNees, Wallace & Nurick
100 Pine St.
P.O. Box 1166
Harrisburg, PA 17108-1166
717-237-5267
Fax: 17172375300
Email: hfreedenberg@mwn.com
LEAD ATTORNEY
ATTORNEY TO BE NOTICED

TM Reg. # 1,986,822
2,138,566
2,187,189
1,031,836
1,038,025

Paul C. Llewellyn
Kaye Scholer LLP
425 Park Avenue
New York, NY 10022
(212) 836-8000
Email: pllewellyn@kayescholer.com
LEAD ATTORNEY
ATTORNEY TO BE NOTICED

Plaintiff

Hershey Chocolate & Confectionery Corporation

represented by **Harvey Freedenberg**
(See above for address)
LEAD ATTORNEY
ATTORNEY TO BE NOTICED

Paul C. Llewellyn
(See above for address)
LEAD ATTORNEY
ATTORNEY TO BE NOTICED

V.

Defendant

Vermont Nut Free Chocolates

Company, Inc.

Date Filed	#	Docket Text
03/14/2007	1	COMPLAINT - N/C to cnsl.; jury trial demanded. (Filing fee \$350, Receipt Number 111000924) (Attachments: # 1 Exhibit(s) A# 2 Exhibit (s) B# 3 Receipt# 4 Civil Cover Sheet)(jc) (Entered: 03/15/2007)
03/14/2007	2	SUMMONS ISSUED as to defendant. (jc) (Entered: 03/15/2007)
03/15/2007	3	SPECIAL ADMISSION FORM AND ECF REGISTRATION FORM SENT to Paul C. Llewellyn, Esquire. (jc) (Entered: 03/15/2007)
03/15/2007	4	DISCLOSURE STATEMENT PURSUANT TO FRCP 7.1. (jc) (Entered: 03/16/2007)
03/16/2007	5	LETTER addressed to counsel Re: Case Assignment and Procedures. Signed by Judge Yvette Kane on March 16, 2007. (sc) (Entered: 03/16/2007)
04/30/2007	6	SCHEDULING ORDER: - IT IS HEREBY ORDERED that the Case Management Conference is set for 8/1/2007 at 10:00 AM via telephone. Pltf's cnsl shall initiate the call. The Joint Case Mgmt Plan is due by 8/27/07. Signed by Judge Yvette Kane on April 30, 2007. (sc) (Entered: 04/30/2007)
05/01/2007	7	AMENDED SCHEDULING ORDER - CMC is scheduled for 8/1/07 at 10:00am via telephone. The Joint Case Mgmt Plan is due no later than *7/27/07. 4 Signed by Judge Yvette Kane on May 1, 2007. (sc) (Entered: 05/01/2007)
05/10/2007	8	LETTER - from deputy clerk to Commissioner of Patents and Trademarks re: new case. (jc) (Entered: 05/10/2007)

ORIGINAL

IN THE UNITED STATES DISTRICT COURT
MIDDLE DISTRICT OF PENNSYLVANIA

THE HERSHEY COMPANY and
HERSHEY CHOCOLATE &
CONFECTIONERY CORPORATION,

Plaintiffs,

v.

VERMONT NUT FREE CHOCOLATES
COMPANY, INC.,

Defendant.

CIVIL ACTION NO. 1:07-09-483

JURY TRIAL DEMANDED

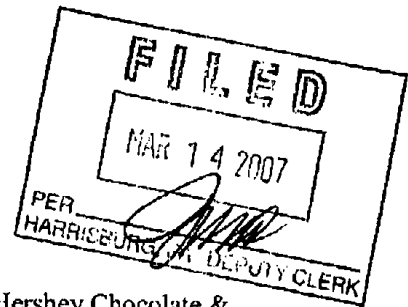

COMPLAINT

Plaintiff's The Hershey Company ("Hershey Company") and Hershey Chocolate & Confectionery Corporation ("Hershey Chocolate") (hereinafter collectively referred to as "Hershey"), for their complaint against defendant Vermont Nut Free Chocolates Company, Inc. ("defendant" or "Vermont") for trademark infringement, trade dress infringement, false designation of origin, trade dress dilution and unfair competition, plead and allege as follows:

NATURE AND BASIS OF THE ACTION

1. This action is brought by Hershey against Vermont under the Lanham Act, 15 U.S.C. § 1051 *et seq.*, and state law, seeking preliminary and permanent injunctive relief, profits, damages and other relief relating to defendant's knowing adoption and use of a conical product configuration for a chocolate candy product which it sells in a conical, foil-wrapped packaging configuration that infringes and dilutes the well-known, federally registered trade dresses used in connection with Hershey's KISSES[®] line of products.

2. Hershey Chocolate is the owner and Hershey Company the licensee of the famous, federally registered KISSES[®] product trade dress, consisting of a conically-shaped chocolate candy (the "Kisses Product Trade Dress") and the famous, federally registered KISSES[®] packaging trade dress, consisting of a conical foil-wrapped packaging similar in shape to the Kisses Product Trade Dress (the "Kisses Packaging Trade Dress") (together with the Kisses Product Trade Dress, the "Kisses Trade Dresses"). Hershey uses Kisses Trade Dresses in connection with a variety of conical, foil-wrapped chocolate candies offered in silver foil wrapping as well as various other colors. Hershey's KISSES[®] brand products and the Kisses Trade Dresses have achieved universal fame and monumental sales, and the marks are well known to consumers throughout the United States.

3. The Kisses Trade Dresses have been widely advertised in the United States for decades on television, in print advertising and in other media, and Hershey has made billions of dollars of sales of KISSES[®] products under the Kisses Trade Dresses throughout the United States. As a result of Hershey's longstanding use and extensive advertising of the Kisses Trade Dresses, the trade dresses have developed strong secondary meaning and are famous among consumers, who have come to associate the Kisses Trade Dresses and their prominent conical shape and foil-wrapped conical shape exclusively with chocolate candy products emanating from Hershey.

4. Defendant has adopted for its "Chocolate Drop" chocolate candy product a conical product configuration and conical foil-wrapped packaging configuration (as in the Kisses Trade Dresses) that infringes the Kisses Product Trade Dress and Kisses Packaging Trade Dress, and unlawfully trades on the goodwill and reputation Hershey has established through its use and promotion of its products and the Kisses Trade Dresses. Defendant's infringement of the Kisses

Trade Dresses is likely to cause consumers, purchasers and others to be confused or mistaken into believing that defendant's conically-shaped, foil-wrapped Chocolate Drop chocolate candy products originate with, are sponsored or approved by, emanate from, or are otherwise associated with, Hershey or the source of the KISSES[®] brand products. In addition, defendant's use of the nearly identical product configuration and packaging of its chocolate candy products, dilutes the distinctive and famous Kisses Product Trade Dress and Kisses Packaging Trade Dress.

5. Unless such acts of infringement, dilution, unfair competition and false designation of origin are enjoined, Hershey will suffer irreparable injury for which there is no adequate remedy at law.

PARTIES

6. Hershey Company is a corporation organized and existing under the laws of the State of Delaware, with its principal place of business at 100 Crystal A Drive, Hershey, Pennsylvania 17033. Hershey Company is a major manufacturer and seller of chocolate, confectionery and snack products, including the well-known and very successful line of KISSES[®] candy products.

7. Hershey Chocolate is a corporation organized and existing under the laws of the State of Delaware, with its principal place of business at 4860 Robb Street, Wheat Ridge, Colorado 80033. Hershey Chocolate is a wholly-owned subsidiary of Hershey Company and is the owner of the KISSES[®] trademarks and the Kisses Product Trade Dress and Kisses Packaging Trade Dress, which Hershey Chocolate has licensed Hershey Company to use.

8. On information and belief, defendant Vermont is a corporation organized and existing under the laws of the State of Vermont, with an address at 10 Island Circle, Garden Isle, Vermont, 05458. On information and belief, Vermont is engaged in the business of

22nd Floor
Southfield, MI 48075-1238
248-358-4400
Email: mchuey@brookskushman.com
LEAD ATTORNEY
ATTORNEY TO BE NOTICED

Mark A. Grace
Cohen & Grigsby PC
11 Stanwix Street
15th Floor
Pittsburgh, PA 15222-1319
412-297-4900
Email: mgrace@cohenlaw.com
LEAD ATTORNEY
ATTORNEY TO BE NOTICED

Robert C.J. Tuttle
Brooks Kushman P.C.
1000 Town Center
22nd Floor
Southfield, MI 48075-1238
248-358-4400
Email: rtuttle@brookskushman.com
LEAD ATTORNEY
ATTORNEY TO BE NOTICED

Thomas C. Wettach
Cohen & Grigsby, PC
11 Stanwix Street
15th Floor
Pittsburgh, PA 15222
412-297-4900
Email: twettach@cohenlaw.com
LEAD ATTORNEY
ATTORNEY TO BE NOTICED

Jill L. Bradley
Cohen & Grigsby, P.C.
11 Stanwix Street, 15th Floor
Pittsburgh, PA 15222
412-297-4707
Email: jbradley@cohenlaw.com
ATTORNEY TO BE NOTICED

Counterclaim Plaintiff

NARTRON CORPORATION

represented by **Mark D. Chuey**
(See above for address)
LEAD ATTORNEY
ATTORNEY TO BE NOTICED

5
manufacturing, distributing and selling candy products, including the infringing products at issue in this lawsuit.

JURISDICTION AND VENUE

9. The Court has subject matter jurisdiction over the trademark infringement, trademark dilution, false designation of origin and unfair competition claims pursuant to the Lanham Act, 15 U.S.C. § 1121, and pursuant to 28 U.S.C. §§ 1331 and 1338(a) & (b). The Court has subject matter jurisdiction over the claims arising under state law pursuant to 28 U.S.C. § 1332, because there is complete diversity of citizenship and the amount in controversy exceeds \$75,000, exclusive of interest and costs. The Court also has supplemental jurisdiction over the claims arising under state law pursuant to 28 U.S.C. § 1367.

10. The Court has personal jurisdiction over defendant because, upon information and belief, defendant is present and doing business in the Commonwealth of Pennsylvania either directly or through its agents, and sells or has sold its infringing products in the Commonwealth of Pennsylvania.

11. Venue is appropriate in this Court pursuant to 28 U.S.C. § 1391 because defendant is subject to personal jurisdiction in this Judicial District and because a substantial part of the events giving rise to plaintiffs' claims occurred in this Judicial District.

ALLEGATIONS COMMON TO ALL CLAIMS

Hershey and Its KISSES® Trade Dresses

12. For more than a century, Hershey and its predecessors have been among the leading manufacturers of confectionery items in the United States and worldwide.

13. Among Hershey's most famous products is the HERSHEY'S KISSES[®], or simply KISSES[®], chocolate candy, first introduced in 1907, which Hershey manufactures and distributes under the Kisses Product Trade Dress and the Kisses Packaging Trade Dress.

14. The Kisses Product Trade Dress marks are universally recognized symbols of Hershey's goodwill and also are the subject of a number of federal trademark registrations, including:

- Mark consisting of "the configuration of a conically-shaped candy piece approximately 7/8 of an inch high as measured from the base to the pinnacle and 15/16 of an inch in diameter as measured at the base of the candy piece," U.S. Registration No. 1,986,822. Registered on July 16, 1996 for use in connection with candy;
- Mark consisting of "the configuration of a conically-shaped candy piece equal to or larger than 7/8 of an inch high as measured from the base to the pinnacle and 15/16 of an inch in diameter as measured at the base of the candy piece," U.S. Registration No. 2,138,566. Registered on February 24, 1998 for use in connection with candy; and
- Mark consisting of "the configuration of a molded, conically shaped candy piece," U.S. Registration No. 2,187,189. Registered on September 8, 1998 for use in connection with candy.

15. The Hershey's Kisses Packaging Trade Dress marks are universally recognized symbols of Hershey's goodwill and are the subject of a number of federal trademark registrations, including:

- Mark consisting of "the overall, individual, silver colored wrapping of the goods which takes approximately the conformation of the goods," U.S. Registration No. 1,031,836. Registered on January 27, 1976 for use in connection with solid chocolate; and

- Mark consisting of "the overall individual wrapping of the goods which takes approximately the conformation of the goods," U.S. Registration No. 1,038,025. Registered on April 13, 1976 for use in connection with solid chocolate.

16. Rights in the foregoing Hershey marks, copies of the registration certificates for which are attached hereto as Exhibit A, date back for many decades. Many of the foregoing trademark registrations have achieved incontestable status under the Lanham Act, including Reg. Nos. 1,986,822, 2,138,566 and 2,187,189.

17. While Hershey Company has offered HERSHEY'S KISSES[®] candy wrapped in different color foil, such as red, green, purple or gold, the most widely known and famous variation of the Kisses Packaging Trade Dress features a silver foil wrapping.

18. Over the years, the Kisses Product Trade Dress and Kisses Packaging Trade Dress have been used extensively not only in connection with candy, but also with various gift items such as candles, paperweights, crystal howls, clocks and Christmas ornaments. The Kisses Trade Dresses have been the subject of extensive advertising and promotion in a variety of media, including television, print and the Internet, and the HERSHEY'S KISSES[®] family of products have been highly successful and are sold worldwide. In the United States alone, Hershey sells hundreds of millions of dollars of KISSES[®] brand products bearing the Kisses Trade Dress annually.

19. By virtue of Hershey's substantial use, sales and promotion of its products using the Kisses Trade Dresses, and by virtue of the non-functional nature of those trade dresses, the marks have become well-known, have become distinctive of Hershey's products, and have come to serve to identify and indicate the source of Hershey's product to consumers and the trade. Hershey has developed for itself and its products substantial goodwill and an excellent reputation among actual and potential purchasers and users of its products.

20. In light of the distinctiveness of the Kisses Trade Dresses, the duration and extent of Hershey's sales, marketing and use of these marks throughout the United States, and the registration of these marks, the Kisses Trade Dresses are distinctive and famous within the meaning of Section 43(c) of the Lanham Act, 15 U.S.C. §1125(c).

21. Hershey has acted with diligence in policing the unauthorized use and misuse by other parties of trademarks similar to or identical to the famous Kisses Product Trade Dress or Kisses Packaging Trade Dress when such uses have come to Hershey's attention.

Defendant's Unauthorized Copying and Use of the KISSES® Trade Dresses

22. Well after Hershey first began using its Kisses Trade Dresses for its conically-shaped chocolate candy products, and after the Kisses Trade Dresses had become famous, defendant commenced manufacturing, distributing and marketing a chocolate candy product featuring a conically-shaped product configuration virtually identical to the Kisses Product Trade Dress. In addition, should there be any doubt as to defendant's intent to mimic and trade upon the Kisses Trade Dresses, defendant's chocolate candy product is individually packaged – like the Kisses Packaging Trade Dress – with silver colored foil wrapping that takes the conformation of defendant's goods. (A photograph showing defendant's infringing product configuration and packaging for its Chocolate Drop product is attached as Exhibit B).

23. On information and belief, defendant markets, distributes and sells its candies in their infringing packaging in the United States, including in the Commonwealth of Pennsylvania. On information and belief, defendant distributes and sells its infringing products to online and traditional retail stores and directly to consumers through other channels of trade, including through catalogs and websites available to consumers in the Commonwealth of Pennsylvania and within this Judicial District.

**Likelihood of Confusion and Dilution Resulting from Defendant's
Unauthorized Copying and Use of the KISSES[®] Trade Dress.**

24. Defendant has not now and never has been authorized by Hershey or its affiliates to use either the Kisses Product Trade Dress or the Kisses Packaging Trade Dress, or any variation thereof in connection with its products.

25. On information and belief, the defendant's infringing product is sold in similar stores and channels of trade as Hershey's KISSES[®] products. Both products are in the same general category of chocolate candy, and are sold to many of the same retailers and consumers.

26. Defendant's use of a conically-shaped product configuration and package design confusingly similar to the Kisses Trade Dresses, particularly in conjunction with chocolate candy products, is likely to cause confusion, mistake or deception of purchasers and the consuming public as to the source or origin of defendant's goods. A substantial number of actual and potential purchasers and consumers, upon encountering defendant's products or advertisements bearing defendant's trade dress, are likely to mistakenly believe that defendant's goods originate with, or are licensed, approved, or sponsored by, or otherwise affiliated with or related to, Hershey or its products.

27. Defendant's use of a conically-shaped product configuration and packaging design similar to the Kisses Trade Dresses also has caused and is likely to cause dilution of the famous Kisses Trade Dresses, by lessening their capacity to identify and distinguish products marketed and sold by Hershey under the Kisses Trade Dresses and by tarnishing those famous trade dresses.

28. Defendant's acts are causing and will continue to cause damage and irreparable harm to Hershey and to its valuable reputation and goodwill with purchasers and consumers.

FIRST CLAIM FOR RELIEF
Infringement of Federally Registered Mark
(15 U.S.C. § 1114(1)(a))

29. Plaintiffs repeat and reallege paragraphs 1 through 28 of this Complaint as if fully set forth herein.

30. This claim is for the infringement of a trademark registered in the United States Patent and Trademark Office, pursuant to Section 32(1) of the Lanham Act, 15 U.S.C. § 1114(1)(a), as amended.

31. The conical product configuration and foil-wrapped packaging configuration used by defendant are confusingly similar to, and a colorable imitation of, the federally registered Kisses Product Trade Dress and Kisses Packaging Trade Dress, and infringe Hershey's trademark registrations covering those marks. Defendant's unauthorized use of the conical product configuration and its foil-wrapped packaging configuration are likely to cause confusion and mistake and to deceive the public as to the approval, sponsorship, license, source or origin of defendant's products.

32. On information and belief, defendant's acts of trademark infringement have been done willfully and deliberately and defendant has profited and been unjustly enriched by sales that defendant would not otherwise have made but for its unlawful conduct.

33. Defendant's willful and deliberate acts described above have caused injury and damages to plaintiffs, and have caused irreparable injury to plaintiffs' goodwill and reputation, and, unless enjoined, will cause further irreparable injury, whereby plaintiffs have no adequate remedy at law.

SECOND CLAIM FOR RELIEF
Trade Dress Infringement, False Designation of Origin and Unfair Competition
(15 U.S.C. § 1125(a))

34. Plaintiff's repeat and reallege paragraphs 1 through 28 of this Complaint as if fully set forth herein.

35. This claim is for trade dress infringement, false designation of origin and unfair competition in violation of Section 43(a) of the Lanham Act, 15 U.S.C. § 1125(a).

36. By its unauthorized use of a conical product configuration and foil-wrapped packaging configuration for its Chocolate Drop candy products, defendant has infringed Hershey's Kisses Product Trade Dress and Kisses Packaging Trade Dress, falsely designated the origin of its products, and competed unfairly with plaintiffs, in violation of 15 U.S.C. § 1125(a).

37. On information and belief, defendant's acts of trade dress infringement, false designation of origin and unfair competition have been done willfully and deliberately and defendant has profited and been unjustly enriched by sales that it would not otherwise have made but for its unlawful conduct.

38. Defendant's acts described above have caused injury and damages to plaintiffs, have caused irreparable injury to plaintiffs' goodwill and reputation, and, unless enjoined, will cause further irreparable injury, whereby plaintiffs have no adequate remedy at law.

THIRD CLAIM FOR RELIEF
Trademark Dilution
(15 U.S.C. § 1125(c))

39. Plaintiff's repeat and reallege paragraphs 1 through 28 of this Complaint as if fully set forth herein.

40. This claim is for the dilution of trademarks pursuant to Section 43(c) of the Lanham Act, 15 U.S.C. § 1125(c), as amended by the Trademark Dilution Revision Act of 2006.

41. The Kisses Product Trade Dress (the conical product configuration) registered under U.S. Reg. No. 186,828, 1,986,822, 2,138,566, and 2,187,189, and the Kisses Packaging

Trade Dress (the foil-wrapped packaging configuration) registered under U.S. Reg. Nos. 1,031,836 and 1,038,025, are distinctive and famous within the meaning of 15 U.S.C. § 1125(c), and were distinctive and famous prior to the date of defendant's conduct challenged herein.

42. Defendant's conduct, as described above, is likely to dilute and is diluting the distinctive quality of the famous Kisses Trade Dresses in that defendant's challenged trade dresses are likely to create and have created an association between defendant's trade dresses and Hershey's famous Kisses Trade Dresses, which impairs the distinctiveness of those famous marks and lessens the capacity of those famous marks to identify and distinguish products marketed and sold by plaintiffs under those marks.

43. To the extent that defendant's product is viewed as being less than satisfactory to consumers, plaintiffs' business reputation and goodwill and the reputation and goodwill of plaintiffs' famous Kisses Trade Dresses are likely to be and will be tarnished and injured.

44. On information and belief, defendant's acts of trademark dilution have been done willfully and deliberately and defendant has profited and been unjustly enriched by sales that defendant would not otherwise have made but for its unlawful conduct.

45. Defendant's acts described above are likely to cause and have caused injury and damage to plaintiffs' goodwill and reputation and, unless enjoined, will cause further irreparable injury, whereby plaintiffs have no adequate remedy at law.

FOURTH CLAIM FOR RELIEF
Common Law Trademark Infringement and Unfair Competition

46. Plaintiffs repeat and reallege paragraphs 1 through 28 of this Complaint as if fully set forth herein.

47. This claim is for trademark infringement and unfair competition in violation of the common law of the Commonwealth of Pennsylvania.

48. Defendant's use of its infringing conically-shaped product configuration and package design, as described above, constitutes common law trademark infringement, passing off and unfair competition in violation of common law.

49. On information and belief, defendant's acts of common law trademark infringement, passing off and unfair competition have been done willfully and deliberately and defendant has profited and been unjustly enriched by sales that defendant would not otherwise have made but for its unlawful conduct.

50. Defendant's acts described above have caused injury and damages to plaintiffs, and have caused irreparable injury to plaintiffs' goodwill and reputation and, unless enjoined, will cause further irreparable injury, whereby plaintiffs have no adequate remedy at law.

FIFTH CLAIM FOR RELIEF
Trademark Dilution Under
Pennsylvania Cons. Stat. Ann. Tit. 54 Section 1124

51. Plaintiffs repeat and reallege paragraphs 1 through 28 of this Complaint as if fully set forth herein.

52. This claim is for the dilution of trademarks and injury to business or reputation under Pa. Cons. Stat. Ann. Tit. 54 § 1124.

53. The federally-registered Kisses Product Trade Dress (the conical product configuration), and the federally-registered Kisses Packaging Trade Dress (the foil-wrapped packaging configuration) are famous marks in the Commonwealth of Pennsylvania within the meaning of Pa. Cons. Stat. Ann. Tit. 54 § 1124, and were famous prior to the date of defendant's adoption and use of similar trade dresses in connection with sales and advertising for its candy products.

54. Defendant's conduct, as described above, is diluting and will dilute the distinctive quality of Hershey's famous Kisses Trade Dresses, thereby lessening the capacity of those marks to identify and distinguish products marketed and sold by plaintiffs under the Kisses Trade Dresses.

55. To the extent the defendant's product is viewed as being less than satisfactory to consumers, plaintiffs' business reputation and goodwill and the reputation and goodwill of plaintiffs' famous trade dress is being and will be tarnished and injured.

56. Defendant's acts described above have caused injury and damages to plaintiffs, and have caused irreparable injury to plaintiffs' goodwill and reputation and, unless enjoined, will cause further irreparable injury, whereby plaintiffs have no adequate remedy at law.

PRAYER FOR RELIEF

WHEREFORE, Hershey prays that this Court enter judgment against defendant as follows:

A. Granting preliminary and permanent injunctive relief restraining defendant, its officers, directors, agents, employees, servants, attorneys, successors, assigns and others controlling, controlled by or affiliated with defendant and all those in privity or active concert or participation with any of the foregoing (including without limitation each distributor or reseller of defendant's Chocolate Drops or other candy products), and all those who receive actual notice by personal service or otherwise:

(1) from using, in writing or in any media, the Kisses Product Trade Dress or any other product configuration confusingly similar to plaintiffs' Kisses Product Trade Dress for any purpose;

Mark A. Grace
 (See above for address)
LEAD ATTORNEY
ATTORNEY TO BE NOTICED

Robert C.J. Tuttle
 (See above for address)
LEAD ATTORNEY
ATTORNEY TO BE NOTICED

Thomas C. Wettach
 (See above for address)
LEAD ATTORNEY
ATTORNEY TO BE NOTICED

Jill L. Bradley
 (See above for address)
ATTORNEY TO BE NOTICED

V.
Counterclaim Defendant
QRG, LTD.

represented by **Andrew E. Falsetti**
 (See above for address)
LEAD ATTORNEY
ATTORNEY TO BE NOTICED

Gene A. Tabachnick
 (See above for address)
LEAD ATTORNEY
ATTORNEY TO BE NOTICED

Robert B. Hoffman
 Wolf Block Schorr and Solis-Cohen,
 LLP
 213 Market Street, 9th Floor
 Harrisburg, PA 17101
 (717) 237-7182
 Email: rhoffman@wolfblock.com
LEAD ATTORNEY
ATTORNEY TO BE NOTICED

Date Filed	#	Docket Text
09/12/2006	<p>1</p>	<p>Case transferred in from District of Western District of Pennsylvania; Case Number 2:06-CV-500. Original file with documents numbered 1-17, certified copy of transfer order and docket sheet received., filed by QRG, LTD.. (Attachments: # 1 Civil Cover Sheet # 2 Receipt# 3 Doc. 2-</p>

(2) from using, in writing or in any media, the Kisses Packaging Trade Dress or any other packaging configuration confusingly similar to plaintiffs' Kisses Packaging Trade Dress for any purpose; and

(3) from otherwise competing unfairly with plaintiffs;

B. Ordering that defendant be adjudged to have violated Sections 32, 43(a) and 43(c) of the Lanham Act, 15 U.S.C. §§ 1114, 1125(a) and 1125(c), to have committed acts of trademark infringement, trade dress infringement, false designation of origin, unfair competition and trade dress dilution, and to have caused trademark dilution and injury to business or reputation in violation of Pennsylvania Cons. Stat Ann. Title 54 § 1124;

C. Ordering an accounting of all gains, profits, savings and advantages realized by defendant from its aforesaid acts of trademark infringement and dilution, false designation of origin and unfair competition, and awarding treble profits pursuant to Pennsylvania Cons. Stat Ann. Title 54 § 1123 on the ground that defendant engaged in its wrongful acts with knowledge or bad faith or under other circumstances warranting treble profits;

D. Awarding such damages as plaintiffs shall establish in consequence of defendant's aforesaid acts of trademark infringement and dilution, false designation of origin and unfair competition, together with appropriate interest thereon, including three times the amount found as actual damages by the trier of fact to properly compensate plaintiffs for their damages, pursuant to 15 U.S.C. § 1117(a) and Pennsylvania Cons. Stat Ann. Title 54 § 1123;

E. Ordering defendant to pay for and cause to be disseminated corrective advertising to ameliorate the adverse consequences of defendant's acts of trademark infringement and dilution, false designation of origin and unfair competition, the content, nature, form and extent of which is to be approved by plaintiffs and this Court;

F. Ordering defendant to recall from all chains of distribution all goods, product packaging, product displays, promotional materials, advertisements, commercials, infomercials and other items, the dissemination by defendant of which would violate the injunction herein requested;

G. Ordering defendant to deliver up for destruction any and all goods, product packaging, product displays, promotional materials, advertisements, commercials and other items in the possession, custody or control of defendant which, if sold, displayed or used, would violate the injunction herein granted, and to disable all web sites to the extent they contain any content, the display or use of which would violate the injunction herein requested;

H. Ordering defendant to pay for and cause to be disseminated to each distributor and reseller of defendant's candy products a notice advising said persons of defendant's acts of trademark infringement and dilution, false designation of origin and unfair competition and advising of the issuance and content of the injunction herein requested;

I. Ordering that, pursuant to Section 34(a) of the Lanham Act, 15 U.S.C. § 1116(a), defendant shall serve upon plaintiffs within thirty (30) days after service on defendant of an order granting an injunction, or such extended period as the Court may direct, a report in writing under oath setting forth in detail the manner and form in which defendant has complied with the injunction;

J. Awarding plaintiffs their costs and expenses of this action;

K. Declaring that this is an exceptional case pursuant to 15 U.S.C. § 1117, because of the willful and deliberate nature of defendant's acts of trademark infringement and dilution, false advertising and unfair competition, and awarding plaintiffs their reasonable attorneys' fees;

L. Declaring that defendant committed its wrongful acts with knowledge or had faith or under circumstances otherwise warranting attorneys fees under Pennsylvania Cons. Stat Ann. Title 54 § 1123, and awarding plaintiffs their reasonable attorneys' fees; and

M. Granting such other and further relief as this Court may deem just and proper.

Dated: March __, 2007

Respectfully submitted,

McNEES WALLACE & NURICK LLC

Of Counsel:

Paul C. Llewellyn
Christopher D. Baker
Kaye Scholer LLP
425 Park Avenue
New York, New York 10022
Telephone: (212) 836-8000
Facsimile: (212) 836-6463

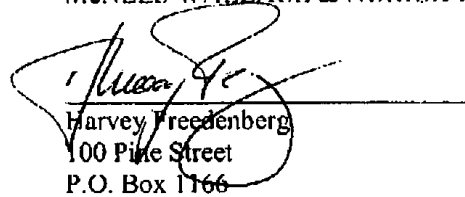
Harvey Freedenberg
100 Pine Street
P.O. Box 1166
Harrisburg, PA 17108-1166
Telephone: (717) 237-5267
Facsimile: (717) 237-5300
Attorneys for Plaintiffs

		<p>Disclosure Statement# <u>4</u> Doc. 3- Summons# <u>5</u> Doc. 4- Motion to Dismiss# <u>6</u> Proposed Order to Motion to Dismiss# <u>7</u> Doc. 5- Brief in Support to Motion to Dismiss# <u>8</u> Exhibit A# <u>9</u> Exhibit B# <u>10</u> Exhibit C# <u>11</u> Doc. 6- Notice of Appearance by Thomas C. Wettach# <u>12</u> Doc. 7- Notice; Response to Motion to Dismiss# <u>13</u> Doc. 8- Motion for Discovery# <u>14</u> Proposed Order for Motion for Discovery# <u>15</u> Exhibit 1# <u>16</u> Exhibit 2# <u>17</u> Exhibit 3# <u>18</u> Exhibit 4# <u>19</u> Exhibit 6# <u>20</u> Exhibit 7# <u>21</u> Exhibit 8# <u>22</u> Exhibit 9# <u>23</u> Exhibit 5 (Motion for Discovery)# <u>24</u> Doc. 9- Notice:Response to Motion for Discovery# <u>25</u> Doc. 10- Brief in Opp. to Motion for Discovery# <u>26</u> Exhibit A (Brief in Opp. to Discovery)# <u>27</u> Exhibit B (Brief in Opp. to Discovery)# <u>28</u> Exhibit C (Brief in Opp. for Discovery)# <u>29</u> Exhibit D- (Brief in Opp. to Discovery)# <u>30</u> Doc. 11- Order Granting Motion for Discovery# <u>31</u> Doc. 12- Brief in Opp. to Motion to Dismiss# <u>32</u> Exhibit A (Brief in Opp. to Motion to Dismiss)# <u>33</u> Exhibit B (Brief in Opp. to Motion to Dismiss)# <u>34</u> Exhibit C (Brief in Opp. to Motion to Dismiss)# <u>35</u> Declaration of Richard T. Ting# <u>36</u> Declaration of Andrew E. Falsetti# <u>37</u> Declaration of Harald Philipp# <u>38</u> Declaration of Chris Bede# <u>39</u> Doc. 3 - Motion for Leave to File a Brief in Reply# <u>40</u> Exhibit A (Motion to File Brief in Reply)# <u>41</u> Doc. 14- Response to Motion for Leave to File a Brief in Reply# <u>42</u> Supplemental Declaration of Richard Ting# <u>43</u> Doc. 15-Order Granting Motion to File Brief in Reply# <u>44</u> Doc. 16- Brief in Reply# <u>45</u> Exhibit A (Brief in Reply)# <u>46</u> Doc. 17- Order Denying Motion to Dismiss. ADDITIONAL ATTACHMENTS ADDED-TRANSFER LETTER AND DOCKET FROM WESTERN DISTRICT OF PA(s) added on 9/13/2006 (crh,). (Entered: 09/13/2006)</p>
09/13/2006	<u>1</u>	SPECIAL ADMISSION FORM SENT to Andrew E. Falsetti, Mark A. Grace & Thomas C. Wettach (crh,) (Entered: 09/13/2006)
09/13/2006	<u>2</u>	Transfer Letter to Counsel (crh,) (Entered: 09/13/2006)
09/20/2006	<u>3</u>	NOTICE:A Case Mgmnt Conf has been set for 10/24/2006 @ 9:15 AM before Honorable Sylvia H. Rambo. This conference is by phone and the call is to initiated by the pltf. unless otherwise agreed upon. A joint case mgmnt plan is to be filed n/l/t 10/17/06.(ma,) (Entered: 09/20/2006)
09/21/2006	<u>4</u>	PETITION FOR SPECIAL ADMISSION (PRO HAC VICE) by Andrew E. Falsetti on behalf of QRG, LTD. Attorney Andrew E. Falsetti is seeking special admission. Filing Fee: 25.00 Receipt Number: 111 146455 (Attachments: # <u>1</u> Receipt) (jc) (Entered: 09/21/2006)
09/21/2006	<u>5</u>	PETITION FOR SPECIAL ADMISSION (PRO HAC VICE) by Gene A. Tabachnick on behalf of QRG, LTD. Attorney Gene A. Tabachnick is seeking special admission. Filing Fee: 25.00 Receipt Number: 111 146455 (Attachments: # <u>1</u> Receipt) (jc) (Entered: 09/21/2006)
09/21/2006	<u>6</u>	NOTICE of Appearance by Robert B. Hoffman on behalf of QRG, LTD. (Hoffman, Robert) (Entered: 09/21/2006)
09/22/2006	<u>7</u>	SPECIAL ADMISSIONS FORM APPROVED as to Andrew Falsetti, Esq. on behalf of ORG, LTDSigned by Judge Sylvia H. Rambo on

		09/22/06. (ma,) (Entered: 09/22/2006)
09/22/2006	● <u>8</u>	SPECIAL ADMISSIONS FORM APPROVED as to Gene Tabachnick, Esq. on behalf of QRG, LTD Signed by Judge Sylvia H. Rambo on 09/22/06. (ma,) (Entered: 09/22/2006)
09/29/2006	● <u>9</u>	PETITION FOR SPECIAL ADMISSION (PRO HAC VICE) by Mark D. Chuey on behalf of NARTRON CORPORATION Attorney Mark D. Chuey is seeking special admission. Filing Fee: 25.00 Receipt Number: 111 146486 (crh,) (Entered: 09/29/2006)
09/29/2006	● <u>10</u>	PETITION FOR SPECIAL ADMISSION (PRO HAC VICE) by Robert C.J. Tuttle on behalf of NARTRON CORPORATION Attorney Robert C.J. Tuttle is seeking special admission. Filing Fee: 25.00 Receipt Number: 111 146485. (crh,) (Entered: 09/29/2006)
10/02/2006	● <u>11</u>	SPECIAL ADMISSIONS FORM APPROVED as to Mark D. Chuey, Esq. on behalf of Nartron/Signed by Judge Sylvia H. Rambo on 10/02/06. (ma,) (Entered: 10/02/2006)
10/02/2006	● <u>12</u>	SPECIAL ADMISSIONS FORM APPROVED as to Robert Tuttle, Esq. on behalf of Nartron.Signed by Judge Sylvia H. Rambo on 10/02/06. (ma,) (Entered: 10/02/2006)
10/06/2006	● <u>13</u>	ANSWER to Complaint by NARTRON CORPORATION. (Attachments: # <u>1</u> Exhibit(s) A# <u>2</u> Exhibit(s) B)(Bradley, Jill) (Entered: 10/06/2006)
10/17/2006	● <u>14</u>	CASE MANAGEMENT PLAN by QRG, LTD.. (Falsetti, Andrew) (Entered: 10/17/2006)
10/18/2006	● <u>15</u>	PETITION FOR SPECIAL ADMISSION (PRO HAC VICE) by Mark A. Grace on behalf of NARTRON CORPORATION Attorney Mark A. Grace is seeking special admission. Filing Fee: 25.00 Receipt Number: 111 146621. (crh,) (Entered: 10/18/2006)
10/18/2006	● <u>16</u>	PETITION FOR SPECIAL ADMISSION (PRO HAC VICE) by Thomas C. Wettach on behalf of NARTRON CORPORATION Attorney Thomas C. Wettach is seeking special admission. Filing Fee: 25.00 Receipt Number: 111 146621. (crh,) (Entered: 10/18/2006)
10/19/2006	● <u>17</u>	SPECIAL ADMISSIONS FORM APPROVED as to Mark Grace, Esq. on behalf of Nartron Signed by Judge Sylvia H. Rambo on 10/19/06. (ma,) (Entered: 10/19/2006)
10/19/2006	● <u>18</u>	SPECIAL ADMISSIONS FORM APPROVED as to Thomas Wettach, Esq. on behalf of Nartron Signed by Judge Sylvia H. Rambo on 10/19/06. (ma,) (Entered: 10/19/2006)
10/24/2006	● <u>20</u>	ORDER - STANDARD CASE MANAGEMENT TRACK Case placed on the 08/2007 trial list. Cases on this list are scheduled to begin on 9/4/2007 following all j/s's starting at 9:30 AM. A date certain may be discussed at the PTC which is set for 8/17/2007 @ 1:30 PM; Discovery due by 2/28/2007. Dispositive Mtns due by 6/20/2007. PTMs due by

		8/10/2007. See order for other ddls. Signed by Judge Sylvia H. Rambo on 10/24/06. (ma,) (Entered: 10/24/2006)
11/01/2006	● <u>21</u>	MOTION to Dismiss <i>Pursuant to Fed.R.Civ.P. 12(b)(1)</i> by NARTRON CORPORATION. (Attachments: # <u>1</u> Certificate of Compliance With Local Rule 7.1# <u>2</u> Proposed Order)(Grace, Mark) (Entered: 11/01/2006)
11/01/2006	● <u>22</u>	BRIEF IN SUPPORT re <u>21</u> MOTION to Dismiss <i>Pursuant to Fed.R.Civ.P. 12(b)(1)</i> filed by NARTRON CORPORATION. (Attachments: # <u>1</u> Declaration of John E. Nemazi# <u>2</u> Exhibit(s) A - G) (Grace, Mark) (Entered: 11/01/2006)
11/16/2006	● <u>23</u>	BRIEF IN OPPOSITION re <u>21</u> MOTION to Dismiss <i>Pursuant to Fed.R.Civ.P. 12(b)(1)</i> filed by QRG, LTD.. (Attachments: # <u>1</u> Affidavit /Declaration of Harald Philipp# <u>2</u> Exhibit(s) 1# <u>3</u> Exhibit(s) 2# <u>4</u> Exhibit(s) 3# <u>5</u> Exhibit(s) 4# <u>6</u> Exhibit(s) 5# <u>7</u> Exhibit(s) 6# <u>8</u> Exhibit(s) 7)(Falsetti, Andrew) (Entered: 11/16/2006)
11/27/2006	● <u>24</u>	REPLY BRIEF re <u>21</u> MOTION to Dismiss <i>Pursuant to Fed.R.Civ.P. 12(b)(1)</i> filed by NARTRON CORPORATION. (Attachments: # <u>1</u> Exhibit(s) 1)(Grace, Mark) (Entered: 11/27/2006)
11/30/2006	● <u>25</u>	MOTION to Clarify <i>The Case Caption</i> by QRG, LTD.. (Attachments: # <u>1</u> Certificate of Compliance with Local Rule 7.1# <u>2</u> Proposed Order) (Falsetti, Andrew) (Entered: 11/30/2006)
12/01/2006	● <u>26</u>	BRIEF IN SUPPORT re <u>25</u> MOTION to Clarify <i>The Case Caption</i> filed by QRG, LTD..(Falsetti, Andrew) (Entered: 12/01/2006)
12/01/2006	● <u>27</u>	ORDER deferring ruling on Motion to Clarify <u>25</u> pending decision on dft's mtn to dismissSigned by Judge Sylvia H. Rambo on 12/01/06 (ma,) (Entered: 12/01/2006)
02/12/2007	● <u>29</u>	NOTICE by QRG, LTD. of <i>Dismissal of Related Action</i> (Attachments: # <u>1</u> Appendix Eastern District of Michigan Order and Opinion Granting Motion to Dismiss)(Falsetti, Andrew) (Entered: 02/12/2007)
03/02/2007	● <u>30</u>	MEMORANDUM AND ORDER: Denying in part dft's mtn to dismiss <u>21</u> as follows: a) The Court will reserve ruling with regard to the "capacitivetouch sensor products and related components" issue and grant Pltf lv to amend the complaint on or before 4/2/07.b) Mtn is denied in all other respects.2) Pltf's Mtn to Clarify the Case Caption <u>25</u> is GRANTED. The Clrk shall change the case caption as to pltf to read: "QRG, Ltd., a/k/a Quantum Research Group,Ltd., Plaintiff." All future filings shall display this caption. 3) An amended cmo will follow.Signed by Judge Sylvia H. Rambo on 03/02/07 (ma,) (Entered: 03/02/2007)
03/02/2007	● <u>31</u>	AMENDED CASE MANAGEMENT ORDER: J/S and Trial continued to the 10/1/2007 list beginning at 9:30 AM before Honorable Sylvia H. Rambo. Discovery due by 3/30/2007. Dispositive Mts ddl 7/20/2007. PTMs due by 9/7/2007. PTC rescheduled for 9/14/2007 @ 10:00 AM before Honorable Sylvia H. Rambo. See order for other ddls.Signed by Judge Sylvia H. Rambo on 03/02/07. (ma,) (Entered: 03/02/2007)

03/08/2007	● <u>32</u>	AMENDED COMPLAINT against NARTRON CORPORATION, filed by QRG, LTD..(Falsetti, Andrew) (Entered: 03/08/2007)
03/19/2007	● <u>33</u>	ANSWER to Amended Complaint, COUNTERCLAIM against all defendants by NARTRON CORPORATION.(Grace, Mark) (Entered: 03/19/2007)
03/20/2007	●	Correction made to docket sheet to reflect QRG, LTD. as the Counterclaim Defendant with appropriate counsel listed as per the 3/19/07 Amended Complaint and Counterclaim <u>33</u> . (dfm) (Entered: 03/20/2007)
03/23/2007	● <u>34</u>	MOTION to Strike <i>Counterclaim</i> by QRG, LTD.. (Attachments: # <u>1</u> Exhibit(s) A# <u>2</u> Exhibit(s) B# <u>3</u> Exhibit(s) C# <u>4</u> Exhibit(s) D# <u>5</u> Brief in Support# <u>6</u> Proposed Order)(Falsetti, Andrew) (Entered: 03/23/2007)
03/26/2007	● <u>35</u>	BRIEF IN SUPPORT re <u>34</u> MOTION to Strike <i>Counterclaim</i> filed by QRG, LTD..(Falsetti, Andrew) (Entered: 03/26/2007)
03/29/2007	● <u>36</u>	REPLY BRIEF re <u>34</u> MOTION to Strike <i>Counterclaim</i> filed by NARTRON CORPORATION. (Attachments: # <u>1</u> Exhibit(s) A# <u>2</u> Exhibit(s) B# <u>3</u> Exhibit(s) C - Part 1# <u>4</u> Exhibit(s) C - Part 2# <u>5</u> Exhibit(s) D# <u>6</u> Exhibit(s) E# <u>7</u> Exhibit(s) F# <u>8</u> Exhibit(s) G# <u>9</u> Exhibit(s) H# <u>10</u> Exhibit(s) I)(Grace, Mark) (Entered: 03/29/2007)
03/29/2007	● <u>37</u>	CERTIFICATE of of Compliance by NARTRON CORPORATION re <u>36</u> Reply Brief,. (Grace, Mark) (Entered: 03/29/2007)
04/12/2007	● <u>38</u>	REPLY BRIEF re <u>34</u> MOTION to Strike <i>Counterclaim</i> filed by QRG, LTD..(Falsetti, Andrew) (Entered: 04/12/2007)
04/23/2007	● <u>39</u>	MEMORANDUM AND ORDER denying pltf's Motion to Strike <u>34</u> .Signed by Judge Sylvia H. Rambo on 04/23/07 (ma,) (Entered: 04/23/2007)
04/23/2007	● <u>40</u>	NOTICE: A scheduling Conference has been scheduled for 5/10/2007 @ 9:00 AM before Honorable Sylvia H. Rambo. This conference is by phone with the call to be initiated by the pltf.Signed by Judge Sylvia H. Rambo on 04/23/07. (ma,) (Entered: 04/23/2007)
05/07/2007	● <u>41</u>	REPLY/ ANSWER to Counterclaim for Patent Infringement by QRG, LTD..(Falsetti, Andrew) (Entered: 05/07/2007)
05/07/2007	● <u>42</u>	MOTION for Partial Summary Judgment on Plaintiff QRG's Declaratory Judgment Claim for Unenforceability of The Five Nartron Patents-In-Suit by NARTRON CORPORATION.(Grace, Mark) (Entered: 05/07/2007)
05/07/2007	● <u>43</u>	STATEMENT OF FACTS re <u>42</u> MOTION for Partial Summary Judgment on Plaintiff QRG's Declaratory Judgment Claim for Unenforceability of The Five Nartron Patents-In-Suit filed by NARTRON CORPORATION. (Attachments: # <u>1</u> Index of Exhibits# <u>2</u> Exhibit(s) A# <u>3</u> Exhibit(s) B# <u>4</u> Exhibit(s) C)(Grace, Mark) (Entered: 05/07/2007)

05/07/2007	44	BRIEF IN SUPPORT re 42 MOTION for Partial Summary Judgment on Plaintiff QRG's Declaratory Judgment Claim for Unenforceability of The Five Nartron Patents-In-Suit filed by NARTRON CORPORATION. (Grace, Mark) (Entered: 05/07/2007)
05/07/2007	45	EXHIBIT A to Brief in Support by NARTRON CORPORATION re 44 Brief in Support. (Grace, Mark) (Entered: 05/07/2007)
05/07/2007	46	EXHIBIT PROPOSED ORDER by NARTRON CORPORATION re 42 MOTION for Partial Summary Judgment on Plaintiff QRG's Declaratory Judgment Claim for Unenforceability of The Five Nartron Patents-In-Suit. (Grace, Mark) (Entered: 05/07/2007)
05/07/2007	47	MOTION for Partial Summary Judgment that the Nartron Patents-In-Suit Are Not Invalid by NARTRON CORPORATION. (Attachments: # 1 Proposed Order)(Grace, Mark) (Entered: 05/07/2007)
05/07/2007	48	STATEMENT OF FACTS re 47 MOTION for Partial Summary Judgment that the Nartron Patents-In-Suit Are Not Invalid filed by NARTRON CORPORATION. (Attachments: # 1 Index# 2 Exhibit(s) A# 3 Exhibit(s) B# 4 Exhibit(s) C# 5 Exhibit(s) D# 6 Exhibit(s) E)(Grace, Mark) (Entered: 05/07/2007)
05/07/2007	49	BRIEF IN SUPPORT re 47 MOTION for Partial Summary Judgment that the Nartron Patents-In-Suit Are Not Invalid filed by NARTRON CORPORATION. (Attachments: # 1 Exhibit(s) A)(Grace, Mark) (Entered: 05/07/2007)
05/08/2007	50	CERTIFICATE of Compliance with Word-Count Limit by NARTRON CORPORATION re 44 Brief in Support. (Grace, Mark) (Entered: 05/08/2007)
05/08/2007	51	CERTIFICATE of Compliance with Word-Count Limit by NARTRON CORPORATION re 49 Brief in Support. (Grace, Mark) (Entered: 05/08/2007)
05/08/2007		Pursuant to the Local Rules and ECF User Manual, all motions and briefs should be filed simultaneously with their corresponding proposed orders, exhibits and any certificates as attachments to the main documents and not as individual documents. (dfm) (Entered: 05/08/2007)

IN THE UNITED STATES DISTRICT COURT
FOR THE WESTERN DISTRICT OF PENNSYLVANIA

QRG, LTD.,)	
)	
Plaintiff,)	Civil Action No. _____
)	
vs.)	
)	
NARTRON CORPORATION,)	[JURY TRIAL DEMANDED]
)	
Defendant.)	

DECLARATORY JUDGMENT COMPLAINT

Plaintiff QRG, Ltd. ("QRG"), by its counsel Reed Smith LLP, hereby alleges the following for its Declaratory Judgment Complaint against Defendant Nartron Corporation ("Nartron"):

1. This is a civil action arising under the provisions of the Declaratory Judgment Act, 28 U.S.C. §§ 2201 *et seq.*, and the patent laws of the United States, 35 U.S.C. §§ 1 *et seq.*, to declare the rights and legal relations of the parties, an actual justifiable controversy existing between the parties with respect to Plaintiff QRG's free right to make, use, sell, and offer for sale its capacitive touch sensor products and related components which are used in a wide array of products in various industries.

2. Plaintiff is a British corporation with its U.S. office at 651 Holiday Drive, Pittsburgh, Pennsylvania.

UNITED STATES PATENT AND TRADEMARK OFFICE
CERTIFICATE OF CORRECTION

PATENT NO. : 5,796,183
DATED : August 18, 1998
INVENTOR(S) : Byron Hourmand

Page 1 of 3

It is certified that error appears in the above-identified patent and that said Letters Patent is hereby corrected as shown below:

Column 5, line 52, "such a" should be --such as--.

Column 9, line 31, before "water" insert --condensed--.

Column 14, line 35, "is" should be --as--.

Column 13, line 65, "it's" should be --its--.

Column 18, line 38, "references" should be --reference--.

Column 20, line 7, "it's" should be --its-- (both occurrences).

Column 20, line 9, "it's" should be --its--.

Column 20, line 10, "it's" should be --its-- (both occurrences).

Column 20, line 13, "it's" should be --its--.

Column 20, line 20, "it's" should be --its--.

Column 20, line 39, "it's" should be --its--.

Column 20, line 40, "it's" should be --its--.

Column 20, line 46, "it's" should be --its--.

Column 20, line 47, "it's" should be --its--.

UNITED STATES PATENT AND TRADEMARK OFFICE
CERTIFICATE OF CORRECTION

PATENT NO. : 5,796,183
DATED : August 18, 1998
INVENTOR(S) : Byron Hourmand

Page 2 of 3

It is certified that error appears in the above-identified patent and that said Letters Patent is hereby corrected as shown below:

Column 21, line 8, "it's" should be --its--.

Column 21, line 9, "it's" should be --its--.

Column 21, line 15, "it's" should be --its--.

Column 21, line 42, "it's" should be --its--.

Column 21, line 46, "it's" should be --its--.

Column 21, line 47, "it's" should be --its--.

Column 21, line 56, "it's" should be --its--.

Column 22, line 8, "it's" should be --its--.

Column 22, line 13, "schmitt" should be --Schmitt--.

Column 26, lines 22-27, after "microcontroller." delete "by an operator's body . . . higher frequencies."

UNITED STATES PATENT AND TRADEMARK OFFICE
CERTIFICATE OF CORRECTION

PATENT NO. : 5,796,183
DATED : August 18, 1998
INVENTOR(S) : Byron Hourmand

Page 3 of 3

It is certified that error appears in the above-identified patent and that said Letters Patent is hereby corrected as shown below:

Column 27, line 44, after "electrical" insert --path--.

Column 27, line 45, delete "path".

Column 29, line 1, after "when" delete "said".

Signed and Sealed this
Eleventh Day of May, 1999

Attest:



Q. TODD DICKINSON

Attesting Officer

Acting Commissioner of Patents and Trademarks



ede \$ #17 MJ

Atty. Docket No. NAR01 P-310

CERTIFICATE OF MAILING

I hereby certify that this paper, together with all enclosures identified herein, are being deposited with the United States Postal Service as first class mail, addressed to the Assistant Commissioner for Patents, Washington D.C. 20231, on the date indicated below.

1/20/99
Date

Rebecca A. Schwartz
Rebecca A. Schwartz

IN THE UNITED STATES PATENT AND TRADEMARK OFFICE

Patentee : Byron Hourmand
Patent No. : 5,796,183
Issue Date : August 18, 1998

CERTIFICATE

FEB - 4 1999

Assistant Commissioner for Patents
Washington, D.C. 20231

CORRECTION

Dear Sir:

A request is being made for a Certificate of Correction in the above-identified patent, which issued with the following errors identified by page and line from the application file.

- * Page 11, line 9, "such a" should be --such as--.
- Page 19, line 4, before "water" insert --condensed--.
- * Page 31, line 5, "is" should be --as--.
- * Page 30, line 3, "it's" should be --its--.
- * Page 40, line 3, "references" should be --reference--.
- * Page 43, line 8, "it's" should be --its--.
- * Page 43, line 9, "it's" should be --its--.
- * Page 43, line 10, "it's" should be --its-- (all occurrences).
- * Page 43, line 12, "it's" should be --its--.
- * Page 43, line 17, "it's" should be --its--.
- * Page 44, line 8, "it's" should be --its--.
- * Page 44, line 9, "it's" should be --its--.
- * Page 44, line 13, "it's" should be --its-- (both occurrences).
- * Page 45, line 10, "it's" should be --its--.

APPROVED
Mary H. Allen
APR 14 1999
FOR THE COMMISSIONER OF PAT. & T.M.

01/29/1999 RMASAT1 00000207 5796183

01 FC:145

100.00 CP

Patentee : Byron Hourmand
Patent No. : 5,796,183
Page : 2

- * Page 45, line 11, "it's" should be --its--.
- * Page 45, line 14, "it's" should be --its--.
- * Page 46, line 11, "it's" should be --its--.
- * Page 46, line 14, "it's" should be --its-- (both occurrences).
- * Page 46, line 19, "it's" should be --its--.
- * Page 47, line 11, "it's" should be --its--.
- * Page 47, line 15, "schmitt" should be --Schmitt--.

Page 55, claim 7 [11], line 3, after "microcontroller." delete "by an operator's body . . .
higher frequencies."

- * Amendment A, page 11, claim 18, line 12, after "electrical" insert --path--.
 - * Amendment A, page 11, claim 18, line 12, delete "path".
- 312 Amendment, page 1, claim 27, line 11, after "when" delete "said".

Enclosed is the Certificate of Correction Form PTO 1050 identifying errors by column and line from the patent which are chargeable to the Official Printer. Also enclosed is a check for \$100.00 to cover our errors, which are identified with an asterisk. The Commissioner is hereby authorized to charge any additional payment, or to credit any overpayment, to Deposit Account No. 16-2463.

Respectfully submitted,

BYRON HOURMAND

By: Price, Heneveld, Cooper,
DeWitt & Litton

1-20-99
Date

TSC/ras

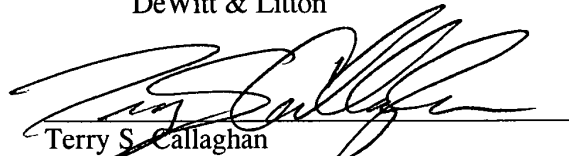
Terry S. Callaghan
Registration No. 34 559
695 Kenmoor, S.E./Post Office Box 2567
Grand Rapids, Michigan 49501
(616) 949-9610

Staple
Here
Only!

UNITED STATES PATENT AND TRADEMARK OFFICE CERTIFICATE OF CORRECTION

PATENT NO. : 5,796,183
DATED : August 18, 1998
INVENTOR(S) : Byron Hourmand

It is certified that error appears in the above-identified patent and that said Letters Patent is hereby corrected as shown below:

- Column 5, line 52, "such a" should be --such as--. *a*
- Column 9, line 31, before "water" insert --condensed--. *C*
- Column 14, line 35, "is" should be --as--. *a*
- Column 13, line 65, "it's" should be --its--. *a*
- Column 18, line 38, "references" should be --reference--. *a*
- Column 20, line 7, "it's" should be --its-- (both occurrences). *a*
- Column 20, line 9, "it's" should be --its--. *a*
- Column 20, line 10, "it's" should be --its-- (both occurrences). *a*
- Column 20, line 13, "it's" should be --its--. *a*
- Column 20, line 20, "it's" should be --its--. *a*
- Column 20, line 39, "it's" should be --its--. *a*
- Column 20, line 40, "it's" should be --its--. *a*
- Column 20, line 46, "it's" should be --its--. *a*
- Column 20, line 47, "it's" should be --its--. *a*
- Column 21, line 8, "it's" should be --its--. *a*
- Column 21, line 9, "it's" should be --its--. *a*
- Column 21, line 15, "it's" should be --its--. *a*

MAILING ADDRESS OF SENDER:

Terry S. Callaghan
Price, Heneveld, Cooper,
DeWitt & Litton
Post Office Box 2567
Grand Rapids, MI 49501

PATENT NO. 5,796,183

No. of add'l copies
@ \$0.50 per page

FORM PTO 1050

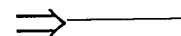

Staple
Here
Only!

UNITED STATES PATENT AND TRADEMARK OFFICE CERTIFICATE OF CORRECTION

PATENT NO. : 5,796,183
DATED : August 18, 1998
INVENTOR(S) : Byron Hourmand

It is certified that error appears in the above-identified patent and that said Letters Patent is hereby corrected as shown below:

- Column 21, line 42, "it's" should be --its--.
- Column 21, line 46, "it's" should be --its--.
- Column 21, line 47, "it's" should be --its--.
- Column 21, line 56, "it's" should be --its--.
- Column 22, line 8, "it's" should be --its--.
- Column 22, line 13, "schmitt" should be --Schmitt--.
- Column 26, lines 22-27, after "microcontroller." delete "by an operator's body . . . higher frequencies."
- Column 27, line 44, after "electrical" insert --path--.
- Column 27, line 45, delete "path".
- Column 29, line 1, after "when" delete "said".

a
a
a
a
a
a
a
a
a
a

MAILING ADDRESS OF SENDER:

Terry S. Callaghan
Price, Heneveld, Cooper,
DeWitt & Litton
Post Office Box 2567
Grand Rapids, MI 49501

PATENT NO. 5,796,183

No. of add'l copies
@ \$0.50 per page

FORM PTO 1050

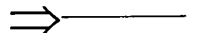

7530

5796183

8-18-98

*** APPLICATION INFORMATION DISPLAY ***

SC/SN: 08/601268	07/20/98 07:27	DETAIL	CONTENTS:
FILDT: 01/31/96		INFORMATION:	20 WPIR O 07/13/98
FATNO: 5796183	PUBNO: F601268		19 N084 B 01/29/98
ISSDT: 08/18/98	PUBDT: 00/00/00		18 EX.A O 03/04/98
ABNDT: 00/00/00	PGPUB CL/SC: /		17 LET. I 02/03/98
APPL: HOURMAND			16 N/= N 10/27/97
LOC: 7530	LOC DT: 06/19/98	BATNO: 000	15 CNTA A 10/27/97
CHG-LQC:	IE TEAM: 08	ISSNO: 33	14 FWIX E 09/29/97
CHGTD-NAME: NOT ASSIGNED			13 A.. I 08/27/97
TOT ACT: 02	STATUS: 100	STADT: 06/16/98	12 N844 I 07/31/97
RESP CD:	START DT: / /	DUE DT: / /	11 MAIL O 04/22/97
EXMR NO/NAME: 72194/KAPLAN, JONATHAN			10 CTNF F 04/14/97
DOCKET DATE: 10/01/96	GAU: 2836	L R CD: 01	09 DOCK D 10/01/96
ATTY DOCK #: NAR01-P-310	LOST N	LOST DT 00/00/00	08 LET. I 05/14/96
APPLN TYPE: 1	TYPE SM ENT: 2	UNMAT PET: N	07 N844 I 05/01/96
CURR CL/SC: 307/116.000	FOR PRIOR CL: N	PET FACM:	06 N844 I 01/31/96
TITLE OF INVENTION: UNAVAIL FOR ACTION: N	PP UNAVAIL: 0		05 LET. I 07/31/96
CAPACITIVE RESPONSIVE ELECTRONIC SWITCHING CIRCUIT			

END OF DISPLAY

TO DISPLAY CONTENTS: PUSH SEND



A large, stylized handwritten signature in black ink, appearing to read 'J. Kaplan' or similar, is written over the lower portion of the page.

8/18/98

PTO UTILITY GRANT
Paper Number 16

The Commissioner of Patents
and Trademarks

Has received an application for a patent for a new and useful invention. The title and description of the invention are enclosed. The requirements of law have been complied with, and it has been determined that a patent on the invention shall be granted under the law.

Therefore, this

United States Patent

Grants to the person(s) having title to this patent the right to exclude others from making, using, offering for sale, or selling the invention throughout the United States of America or importing the invention into the United States of America for the term set forth below, subject to the payment of maintenance fees as provided by law.

If this application was filed prior to June 8, 1995, the term of this patent is the longer of seventeen years from the date of grant of this patent or twenty years from the earliest effective U.S. filing date of the application, subject to any statutory extension.

If this application was filed on or after June 8, 1995, the term of this patent is twenty years from the U.S. filing date, subject to a statutory extension. If the application contains a specific reference to an earlier filed application or applications under 35 U.S.C. 120, 121 or 365(c), the term of the patent is twenty years from the date on which the earliest application was filed, subject to any statutory extension.

Bruce Lehman
Commissioner of Patents and Trademarks
Melvinia Gary
Attest

The
United
States
of
America



Form PTO-1504 (Rev. 2/97)

(RIGHT INSIDE)



**UNITED STATES DEPARTMENT OF COMMERCE
Patent and Trademark Office**

Address: COMMISSIONER OF PATENTS AND TRADEMARKS
Washington, D.C. 20231

APPLICATION NO.	FILING DATE	FIRST NAMED INVENTOR	ATTORNEY DOCKET NO.
08/601,268	01/31/96	HOURMAND	B NAR01-P-310

PRICE HENEVELD COOPER
DEWITT & LITTON
695 KENMOOR DRIVE SE
P O BOX 2567
GRAND RAPIDS MI 49501

B2M1/0304

EXAMINER

KAPLAN, J

ART UNIT

2107

PAPER NUMBER

DATE MAILED: 03/04/98

Please find below and/or attached an Office communication concerning this application or proceeding.

Commissioner of Patents and Trademarks

Supplemental
Notice of Allowability

Application No. 08/601,268	Applicant(s) Hourmand
Examiner Jonathan Kaplan	Group Art Unit 2107



All claims being allowable, PROSECUTION ON THE MERITS IS (OR REMAINS) CLOSED in this application. If not included herewith (or previously mailed), a Notice of Allowance and Issue Fee Due or other appropriate communication will be mailed in due course.

This communication is responsive to the letter mailed 2/3/98

The allowed claim(s) is/are 1-32

The drawings filed on _____ are acceptable.

Acknowledgement is made of a claim for foreign priority under 35 U.S.C. § 119(a)-(d).

All Some* None of the CERTIFIED copies of the priority documents have been
 received.

received in Application No. (Series Code/Serial Number) _____

received in this national stage application from the International Bureau (PCT Rule 17.2(a)).

*Certified copies not received: _____

Acknowledgement is made of a claim for domestic priority under 35 U.S.C. § 119(e).

A SHORTENED STATUTORY PERIOD FOR RESPONSE to comply with the requirements noted below is set to EXPIRE THREE MONTHS FROM THE "DATE MAILED" of this Office action. Failure to timely comply will result in ABANDONMENT of this application. Extensions of time may be obtained under the provisions of 37 CFR 1.136(a).

Note the attached EXAMINER'S AMENDMENT or NOTICE OF INFORMAL APPLICATION, PTO-152, which discloses that the oath or declaration is deficient. A SUBSTITUTE OATH OR DECLARATION IS REQUIRED.

Applicant MUST submit NEW FORMAL DRAWINGS

because the originally filed drawings were declared by applicant to be informal.

including changes required by the Notice of Draftsperson's Patent Drawing Review, PTO-948, attached hereto or to Paper No. _____

including changes required by the proposed drawing correction filed on _____, which has been approved by the examiner.

including changes required by the attached Examiner's Amendment/Comment.

Identifying indicia such as the application number (see 37 CFR 1.84(c)) should be written on the reverse side of the drawings. The drawings should be filed as a separate paper with a transmittal letter addressed to the Official Draftsperson.

Note the attached Examiner's comment regarding REQUIREMENT FOR THE DEPOSIT OF BIOLOGICAL MATERIAL.

Any response to this letter should include, in the upper right hand corner, the APPLICATION NUMBER (SERIES CODE/SERIAL NUMBER). If applicant has received a Notice of Allowance and Issue Fee Due, the ISSUE BATCH NUMBER and DATE of the NOTICE OF ALLOWANCE should also be included.

Attachment(s)

Notice of References Cited, PTO-892

Information Disclosure Statement(s), PTO-1449, Paper No(s). 5

Notice of Draftsperson's Patent Drawing Review, PTO-948

Notice of Informal Patent Application, PTO-152

Interview Summary, PTO-413

Examiner's Amendment/Comment

Examiner's Comment Regarding Requirement for Deposit of Biological Material

Examiner's Statement of Reasons for Allowance

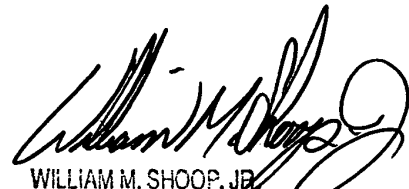
WILLIAM M. SHOOP, JR.
SUPERVISORY PATENT EXAMINER
ART UNIT 217



Express Mail No. Rb7825787641
Sheet 1 of 2

Form PTO-1449

U.S. DEPARTMENT OF COMMERCE
PATENT AND TRADEMARK OFFICE

ATTY. DOCKET NO.

SERIAL NO.

NAR01 P-310

INFORMATION DISCLOSURE STATEMENT
BY APPLICANT

APPLICANTS

Byron Hourmand

FILING DATE

GROUP

U.S. PATENT DOCUMENTS

EXAMINER INITIAL	PATENT NUMBER							ISSUE DATE	NAME	CLASS	SUBCLASS	FILING DATE IF APPROPRIATE
	5	4	5	3	6	4	4					
AK	5	4	5	3	6	4	4	09/26/95	Yap et al.			
	5	3	8	6	2	1	9	01/31/95	Greanias et al.			
	5	2	3	5	2	1	7	08/10/93	Kirton			
	5	2	3	3	2	3	1	08/03/93	Wieth et al.			
	5	2	0	8	5	1	6	05/04/93	Saidian			
	5	0	8	7	8	2	5	02/11/92	Ingraham			
	5	0	6	6	8	9	8	11/19/91	Miller et al.			
	5	0	1	2	1	2	4	04/30/91	Hollaway			
	4	9	3	9	3	8	2	07/03/90	Gruodis			
	4	9	1	0	5	0	4	03/20/90	Eriksson			
	4	8	3	1	2	7	9	05/16/89	Ingraham			
	4	7	5	8	7	3	5	07/19/88	Ingraham			
	4	7	3	1	5	4	8	03/15/88	Ingraham			
	4	4	7	6	4	6	3	10/09/84	Ng et al.			
	4	3	7	4	3	8	1	02/15/83	Ng et al.			
	4	3	6	0	7	3	7	11/23/82	Leopold			
	4	3	2	3	8	2	9	04/06/82	Witney et al.			
	4	3	0	8	4	4	3	12/29/81	Tucker et al.			
	4	2	8	9	9	8	0	09/15/81	McLaughlin			
	4	2	8	9	9	7	2	09/15/81	Wern			
AK	4	2	6	4	8	3	1	04/28/81	Wern			
	4	2	5	7	1	1	7	03/17/81	Besson			

FOREIGN PATENT DOCUMENTS

DOCUMENT NUMBER	PUBLICATION DATE	COUNTRY	CLASS	SUBCLASS	TRANSLATION	
					YES	NO

OTHER DOCUMENTS (Including Author, Title, Date, Pertinent Pages, Etc.)

EXAMINER

Jonathan Kaplan

DATE CONSIDERED

4/11/97

EXAMINER: Initial if citation is considered, whether or not citation is in conformance with MPEP 609; Draw line through citation if not in conformance and not considered. Include copy of this form with next communication to applicant.

Express Mail No. RB782578764U

Sheet 2 of 2



Form PTO-1449 INFORMATION DISCLOSURE STATEMENT BY APPLICANT	U.S. DEPARTMENT OF COMMERCE PATENT AND TRADEMARK OFFICE	ATTY. DOCKET NO. NAR01 P-310	SERIAL NO.
	APPLICANTS Byron Hourmand		
	FILING DATE	GROUP	

U.S. PATENT DOCUMENTS

EXAMINER INITIAL	PATENT NUMBER							ISSUE DATE	NAME	CLASS	SUBCLASS	FILING DATE IF APPROPRIATE
	4	2	4	6	5	3	3					
JK								01/20/61	Chiang			
								12/02/80	Waldron			
								09/02/80	Gibson et al.			
								07/15/80	Conner			
								07/08/80	Deavenport et al.			
								07/01/80	Wern			
								06/26/79	Senk			
								05/01/79	Raupp			
								10/10/78	Petrizio			
								07/18/78	Stone			
								01/31/78	Talmage et al.			
								06/21/77	Holz			
								04/05/77	Moennig			
								10/05/76	Gott et al.			
								06/22/76	Alexander			
								11/11/75	Bellis			
								10/07/75	Hurst et al.			
								08/12/75	Barkan et al.			
								03/19/74	Hurst			
								05/30/72	Bellis			
							03/21/72	Vogelsberg				
							02/08/72	Vogelsberg				
							08/25/69	Adelson et al.				

FOREIGN PATENT DOCUMENTS

DOCUMENT NUMBER	PUBLICATION DATE	COUNTRY	CLASS	SUBCLASS	TRANSLATION	
					YES	NO

OTHER DOCUMENTS (Including Author, Title, Date, Pertinent Pages, Etc.)

EXAMINER <i>Jonathan Kaplan</i>	DATE CONSIDERED <i>4/1/97</i>
------------------------------------	----------------------------------

EXAMINER: Initial if citation is considered, whether or not citation is in conformance with MPEP 609; Draw line through citation if not in conformance and not considered. Include copy of this form with next communication to applicant.

CERTIFICATE OF MAILING

I hereby certify that this paper, together with all enclosures identified herein, are being deposited with the United States Postal Service as first class mail, addressed to the Assistant Commissioner for Patents, Box Issue Fee, Washington D.C. 20231, on the date indicated below.

1/23/98
Date

Rebecca A. Schwartz
Rebecca A. Schwartz

IN THE UNITED STATES PATENT AND TRADEMARK OFFICE

RECEIVED

FEB - 3 1998

Publishing Division
Corres/Allowed Files (10)

Art Unit : 2107
 Applicant : Byron Hourmand
 Appln. No. : 08/601,268
 Filing Date : January 31, 1996
 For : CAPACITIVE RESPONSIVE ELECTRONIC SWITCHING CIRCUIT
 Batch No. : T51

13/1/98
He.
IPAS
Johnson
2-17-98

Assistant Commissioner for Patents
 Box Issue Fee
 Washington, D.C. 20231

JAN 26 1998

REQUEST FOR ACKNOWLEDGEMENT OF CONSIDERATION
 OF PREVIOUSLY-SUBMITTED REFERENCES

This is a request for the Examiner to acknowledge that he had considered the references cited in the Information Disclosure Statement filed for this application on January 31, 1996. Upon review of the undersigned's file prior to payment of the issue fee, it was noticed that the two sheets of Form 1449 that were submitted with that Information Disclosure Statement had been returned to the Applicants with the Office Action mailed April 22, 1997, without the Examiner having had placed his initials in the margin to acknowledge consideration of those references. Applicants therefore respectfully request the Examiner to review the file and acknowledge whether he has considered those references cited in that Information Disclosure

Applicant : Byron Hourmand
Appln. No. : 08/601,268
Page : 2

Statement preferably by mailing a copy of these sheets of Form 1449 bearing his initials. A courtesy copy of this Information Disclosure Statement is attached.

Respectfully submitted,

BYRON HOURMAND

By: Price, Heneveld, Cooper,
DeWitt & Litton

1-23-98
Date

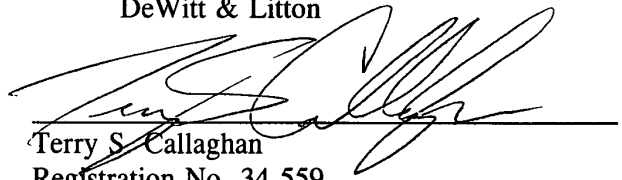

Terry S. Callaghan
Registration No. 34 559
695 Kenmoor, S.E./Post Office Box 2567
Grand Rapids, Michigan 49501
(616) 949-9610

TSC/ras

1-21-1996 4:01PM

6168325525 FROM NARTRON 6168325525

08,601,268 P.4
NO.415 P002/003

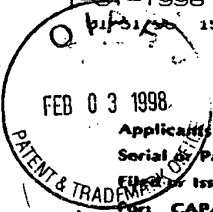

Express Mail No. RB782578764US

GN 2836

Applicants or Patentees: Byron Mourmand
Serial or Patent No.: _____
Filed or Issued: _____
For: CAPACITIVE RESPONSIVE ELECTRONIC SWITCHING CIRCUIT

Noted
OK
1/5/98

VERIFIED STATEMENT (DECLARATION) CLAIMING SMALL ENTITY STATUS (37 C.F.R. § 1.9(f) and 1.27(c)) - SMALL BUSINESS CONCERN

I hereby declare that I am
() the owner of the small business concern identified below:
(X) an official of the small business concern empowered to act on behalf of the concern identified below.

NAME OF CONCERN Nartron Corporation
ADDRESS OF CONCERN 5000 North U.S. 131
Reed City, Michigan 49677-0207

I hereby declare that the above identified small business concern qualifies as a small business concern as defined in 37 C.F.R. § 1.21.3-18, and reproduced in 37 C.F.R. § 1.9(d), for purposes of paying reduced fees under sections 41(a) and (b) of Title 35, United States Code, in that the number of employees of the concern, including those of its affiliates, does not exceed 500 persons. For purposes of this statement, (1) the number of employees of the business concern is the average over the previous fiscal year of the concern of the persons employed on a full-time, part-time or temporary basis during each of the pay periods of the fiscal year, and (2) concerns are affiliates of each other when either, directly or indirectly, one concern controls or has the power to control the other, or a third party or parties controls or has the power to control both.

I hereby declare that rights under contract or law have been conveyed to and remain with the small business concern identified above with regard to the invention, entitled CAPACITIVE RESPONSIVE ELECTRONIC SWITCHING CIRCUIT by inventor Byron Mourmand described in the specification filed herewith.

If the rights held by the above identified small business concern are not exclusive, each individual, concern or organization having rights to the invention is listed below* and no rights to the invention are held by any person, other than the inventor, who could not qualify as an independent inventor under 37 C.F.R. § 1.9(c) or by any concern which would not qualify as a small business concern under 37 C.F.R. § 1.9(d) or a nonprofit organization under 37 C.F.R. § 1.9(e). *NOTE: Separate verified statements are required from each named person, concern or organization having rights to the invention averring to their status as small entities (37 C.F.R. § 1.27).

NAME _____
ADDRESS _____
() INDIVIDUAL (X) SMALL BUSINESS CONCERN () NON-PROFIT ORGANIZATION

NAME _____
ADDRESS _____
() INDIVIDUAL (X) SMALL BUSINESS CONCERN () NON-PROFIT ORGANIZATION

I acknowledge the duty to file, in this application or patent, notification of any change in status resulting in loss of entitlement to small entity status prior to paying, or at the time of paying, the earliest of the issue fee or any maintenance fee due after the date on which status as a small entity is no longer appropriate. (37 C.F.R. § 1.28(b)).

I hereby declare that all statements made herein of my own knowledge are true and that all statements made on information and belief are believed to be true; and further that these statements were made with the knowledge that willful false statements and the like so made are punishable by fine or imprisonment, or both, under Section 1001 of Title 18 of the United States Code, and that such willful false statements may jeopardize the validity of the application, any patent issuing thereon, or any patent to which this verified statement is directed.

NAME OF PERSON SIGNING Dr. Terry Carroll
TITLE OF PERSON OTHER THAN OWNER President
ADDRESS OF PERSON SIGNING 5000 North U.S. 131, Reed City, Michigan 49677-0207
SIGNATURE [Signature] DATE 31 January 1996

MAILED
JUL 15 1998
GROUP 2500

RECEIVED
JUL 17 1998
GROUP 2100

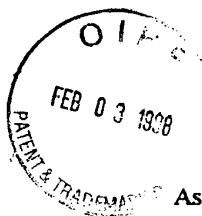

Attorney Docket No. NAR01 P-310
Express Mail No. RB782578764US

DECLARATION AND POWER OF ATTORNEY

As a below named inventor, I hereby declare:

My residence, post office address and citizenship are as stated below next to my name.

I believe I am an original, first and sole inventor of the subject matter which is claimed and for which a patent is sought on the invention entitled **CAPACITIVE RESPONSIVE ELECTRONIC SWITCHING CIRCUIT**, the specification of which is attached hereto.

I have reviewed and understand the contents of the above-identified specification, including the claims, as amended by any amendment referred to above.

I acknowledge the duty to disclose to the United States Patent and Trademark Office (the Office), all information which is known by me to be material to patentability as defined in Title 37, Code of Federal Regulations (C.F.R.), Section 1.56.

POWER OF ATTORNEY

I hereby appoint the patent law firm of Price, Heneveld, Cooper, DeWitt and Litton, P.O. Box 2567, 695 Kenmoor Drive, S.E., Grand Rapids, Michigan 49501, telephone number 616-949-9610, facsimile number 616-957-8196, and the individual patent attorneys and patent agents at such patent law firm, namely, Lloyd A. Heneveld, Reg. No. 17 802; Richard C. Cooper, Reg. No. 19 164; William W. DeWitt, Reg. No. 22 300; Randall G. Litton, Reg. No. 24 013; James A. Mitchell, Reg. No. 25 120; Harold W. Reick, Reg. No. 25 438; Robert J. Carrier, Reg. No. 24 219; Carl S. Clark, Reg. No. 28 288; Daniel L. Girdwood, Reg. No. 34 827; Barry C. Kane, Reg. No. 32 036; Mark J. Farrell, Reg. No. 37 826; Terry S. Callaghan, Reg. No. 34 559; Gunther J. Evanina, Reg. No. 35 502; and Steven C. Wichmann, Reg. No. 37 758, my attorney(s) or agent(s) with full power of substitution and revocation, to prosecute this application and to transact all business in and to receive all correspondence from the Patent and Trademark Office connected therewith.

All statements made herein of my own knowledge are true and all statements made on information and belief are believed to be true, and further, these statements are made with the knowledge that willful false statements and the like are punishable by fine or imprisonment, or both, under 18 U.S.C. § 1001, and that such willful false statements may jeopardize the validity of this application or any patent issued thereon.

Sole inventor:

Byron (NMI) Hourmand Date:
Citizenship: United States of America
Residence: Hersey, Michigan
Post Office Address: 19009 23 Mile Rd.

PB

2,400,000
501 15

PART B - ISSUE FEE TRANSMITTAL

MAILING INSTRUCTIONS: This form should be used for transmitting the ISSUE FEE. Blocks 2 through 6 should be completed where appropriate. All further correspondence including the Issue Fee Receipt, the Patent, advance orders and notification of maintenance fees will be mailed to addressee entered in Block 1 unless you direct otherwise, by: (a) specifying a new correspondence address in Block 3 below; or (b) providing the PTO with a separate "FEE ADDRESS" for maintenance fee notifications with the payment of Issue Fee or thereafter. See reverse for Certificate of Mailing, below.

Under the Paperwork Reduction Act of 1995, no persons are required to respond to a collection of information unless it displays a valid OMB control number.

Burden Hour Statement: This form is estimated to take 0.2 hours to complete. Time will vary depending on the needs of the individual case. Any comments on the amount of time required to complete this form should be sent to the Chief Information Officer, Patent and Trademark Office, Washington, D.C. 20231.

DO NOT SEND FEES OR COMPLETED FORMS TO THIS ADDRESS. SEND TO: Box Issue Fee, Assistant Commissioner for Patents, Washington D.C. 20231

1. CORRESPONDENCE ADDRESS

PRICE HENEVELD COOPER
DEWITT & LITTON
695 KENMOOR DRIVE SE
P O BOX 2567
GRAND RAPIDS MI 49501

21 RECEIVED
Publishing Division
JAN 29 1998
C7

2. INVENTOR(S) ADDRESS CHANGE (Complete only if there is a change)

INVENTOR'S NAME _____

Street Address _____

City, State and ZIP Code _____

CO-INVENTOR'S NAME _____

Street Address _____

City, State and ZIP Code _____

Check if additional changes are enclosed

APPLICATION NO.	FILING DATE	TOTAL CLAIMS	EXAMINER AND GROUP ART UNIT	DATE MAILED
08/601,268	01/31/96	032	KAPLAN, J 2107	10/27/97
First Named Applicant	HOURMAND, BYRON			

TITLE OF INVENTION CAPACITIVE RESPONSIVE ELECTRONIC SWITCHING CIRCUIT

ATTYS DOCKET NO.	CLASS-SUBCLASS	BATCH NO.	APPLN. TYPE	SMALL ENTITY	FEE DUE	DATE DUE
2 NAR01-P-310	307-116.000	TS1	UTILITY	YES	\$660.00	01/27/98

3. Correspondence address change (Complete only if there is a change)

02/09/1998 CASHBY 00000148 08601268
01 FC:242 660.00 DP
02 FC:561 15:00 DP

4. For printing on the patent front page, list the names of not more than 3 registered patent attorneys or agents OR, alternatively, the name of a firm having as a member a registered attorney or agent. If no name is listed, no name will be printed.

Price, Heneveld, Cooper, DeWitt & Litton

2 _____

3 _____

5. ASSIGNMENT DATA TO BE PRINTED ON THE PATENT (print or type)

(1) NAME OF ASSIGNEE: Nartron Corporation

(2) ADDRESS: (CITY & STATE OR COUNTRY) Reed City, Michigan

A. This application is NOT assigned.
 Assignment previously submitted to the Patent and Trademark Office.
 Assignment is being submitted under separate cover. Assignments should be directed to Box ASSIGNMENTS.

PLEASE NOTE: Unless an assignee is identified in Block 5, no assignee data will appear on the patent. Inclusion of assignee data is only appropriate when an assignment has been previously submitted to the PTO or is being submitted under separate cover. Completion of this form is NOT a substitute for filing an assignment.

6a. The following fees are enclosed:
 Issue Fee Advance Order - # of Copies 5

6b. The following fees should be charged to:
 DEPOSIT ACCOUNT NUMBER 16 2463
 (ENCLOSE A COPY OF THIS FORM)
 Issue Fee Advance Order - # of Copies _____
 Any Deficiencies in Enclosed Fees

The COMMISSIONER OF PATENTS AND TRADEMARKS is requested to apply the Issue Fee to the application identified above.

(Authorized Signature) Perry S. Callaghan 34 559 01/26/98

NOTE: The Issue Fee will not be accepted from anyone other than the applicant; a registered attorney or agent; or the assignee or other party in interest as shown by the records of the Patent and Trademark Office.

Certificate of Mailing

Note: If this certificate of mailing is used, it can only be used to transmit the Issue Fee. This certificate cannot be used for any other accompanying papers. Each additional paper, such as an assignment or formal drawing, must have its own certificate of mailing.

I hereby certify that this correspondence is being deposited with the United States Postal Service with sufficient postage as first class mail in an envelope addressed to: Box ISSUE FEE, Assistant Commissioner for Patents, Washington, D.C. 20231

on: January 26, 1998 (Date)

Rebecca A. Schwartz (Name of person making deposit)

Rebecca A. Schwartz (Signature)

1/26/98 (Date)

1. TRANSMIT THIS FORM WITH FEE

PART B—ISSUE FEE TRANSMITTAL

MAILING INSTRUCTIONS: This form should be used for transmitting the **ISSUE FEE**. Blocks 2 through 6 should be completed where appropriate. All further correspondence including the Issue Fee Receipt, the Patent, advance orders and notification of maintenance fees will be mailed to address entered in Block 1 unless you direct otherwise, by: (a) specifying a new correspondence address in Block 3 below; or (b) providing the PTO with a separate "FEE ADDRESS" for maintenance fee notifications with the payment of Issue Fee or thereafter. **See reverse for Certificate of Mailing, below.**

Under the Paperwork Reduction Act of 1995, no persons are required to respond to a collection of information unless it displays a valid OMB control number.

Burden Hour Statement: This form is estimated to take 0.2 hours to complete. Time will vary depending on the needs of the individual case. Any comments on the amount of time required to complete this form should be sent to the Chief Information Officer, Patent and Trademark Office, Washington, D.C. 20231.

DO NOT SEND FEES OR COMPLETED FORMS TO THIS ADDRESS. SEND TO: Box Issue Fee, Assistant Commissioner for Patents, Washington D.C. 20231

1. CORRESPONDENCE ADDRESS		2. INVENTOR(S) ADDRESS CHANGE (Complete only if there is a change)	
PRICE HENEVELD COOPER DEWITT & LITTON 695 KENMOOR DRIVE SE P O BOX 2567 GRAND RAPIDS MI 49501		INVENTOR'S NAME	
		Street Address	
		City, State and ZIP Code	
		CO-INVENTOR'S NAME	
		Street Address	
		City, State and ZIP Code	
<input type="checkbox"/> Check if additional changes are enclosed			

APPLICATION NO.	FILING DATE	TOTAL CLAIMS	EXAMINER AND GROUP ART UNIT	DATE MAILED
08/601,268	01/31/96	032	KAPLAN, J	2107 10/27/97
First Named Applicant	BYRON			
HOURMAND,				

TITLE OF INVENTION: CAPACITIVE RESPONSIVE ELECTRONIC SWITCHING CIRCUIT

ATTY'S DOCKET NO.	CLASS-SUBCLASS	BATCH NO.	APPLN. TYPE	SMALL ENTITY	FEE DUE	DATE DUE
2	NAR01-P-310	307-116.000	T51	UTILITY	YES \$660.00	01/27/98

3. Correspondence address change (Complete only if there is a change)	4. For printing on the patent front page, list the names of not more than 3 registered patent attorneys or agents OR, alternatively, the name of a firm having as a member a registered attorney or agent. If no name is listed, no name will be printed.	Price, Heneveld, Cooper, DeWitt & Litton 1 _____ 2 _____ 3 _____
---	---	---

5. ASSIGNMENT DATA TO BE PRINTED ON THE PATENT (print or type)		6a. The following fees are enclosed:	
(1) NAME OF ASSIGNEE: Nartron Corporation		<input checked="" type="checkbox"/> Issue Fee <input checked="" type="checkbox"/> Advance Order - # of Copies 5	
(2) ADDRESS: (CITY & STATE OR COUNTRY) Reed City, Michigan		6b. The following fees should be charged to:	
		DEPOSIT ACCOUNT NUMBER 16 2463	
A. <input type="checkbox"/> This application is NOT assigned. <input checked="" type="checkbox"/> Assignment previously submitted to the Patent and Trademark Office. <input type="checkbox"/> Assignment is being submitted under separate cover. Assignments should be directed to Box ASSIGNMENTS. PLEASE NOTE: Unless an assignee is identified in Block 5, no assignee data will appear on the patent. Inclusion of assignee data is only appropriate when an assignment has been previously submitted to the PTO or is being submitted under separate cover. Completion of this form is NOT a substitute for filing an assignment.		(ENCLOSE A COPY OF THIS FORM) <input type="checkbox"/> Issue Fee <input type="checkbox"/> Advance Order - # of Copies _____ <input checked="" type="checkbox"/> Any Deficiencies in Enclosed Fees _____ The COMMISSIONER OF PATENTS AND TRADEMARKS is requested to apply the Issue Fee to the application identified above.	
		(Authorized Signature) Perry S. Carraghan 34 559 01/26/98 NOTE: The Issue Fee will not be accepted from anyone other than the applicant, a registered attorney or agent, or the assignee or other party in interest as shown by the records of the Patent and Trademark Office.	

Certificate of Mailing

Note: If this certificate of mailing is used, it can only be used to transmit the Issue Fee. This certificate cannot be used for any other accompanying papers. Each additional paper, such as an assignment or formal drawing, must have its own certificate of mailing.

I hereby certify that this correspondence is being deposited with the United States Postal Service with sufficient postage as first class mail in an envelope addressed to:

**Box ISSUE FEE
Assistant Commissioner for Patents
Washington, D.C. 20231**

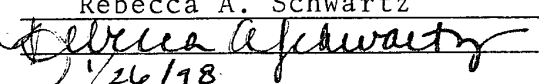
on: January 26, 1998 (Date)
 Rebecca A. Schwartz (Name of person making deposit)
 (Signature)
 1/26/98 (Date)

1. TRANSMIT THIS FORM WITH FEE

28N1

Atty. Docket No. NAR01 P-310

CERTIFICATE OF MAILING

I hereby certify that this paper, together with all enclosures identified herein, are being deposited with the United States Postal Service as first class mail, addressed to the Assistant Commissioner for Patents, Box Issue Fee, Washington D.C. 20231, on the date indicated below.

4/13/97
Date

Rebecca A. Schwartz
Rebecca A. Schwartz

45
#

IN THE UNITED STATES PATENT AND TRADEMARK OFFICE

Art Unit : 2107
Applicant : Byron Hourmand
Appl. No. : 08/601,268
Filing Date : January 31, 1996
For : CAPACITIVE RESPONSIVE ELECTRONIC SWITCHING CIRCUIT
Batch No. : T51

Assistant Commissioner for Patents
Box Issue Fee
Washington, D.C. 20231

Attention: Official Draftsperson

RECEIVED
Publishing Division
NOV 11 1997
16

TRANSMITTAL OF FORMAL DRAWINGS

In response to the Notice of Allowability mailed October 27, 1997, the Applicant requests that the enclosed 13 sheets of formal drawings be entered in the above-identified application. The enclosed drawings correspond to the informal drawings now on file and approved as to content, correct the informalities noted in Form PTO-948 from the Official Draftsperson dated August 1, 1996, and include the corrections filed on August 22, 1997, which were approved by the Examiner in the Notice of Allowability.

Respectfully submitted,

BYRON HOURMAND

By: Price, Heneveld, Cooper,
DeWitt & Litton

11-13-97
Date

Terry S. Callaghan

Terry S. Callaghan
Registration No. 34 559
695 Kenmoor, S.E./Post Office Box 2567
Grand Rapids, Michigan 49501
(616) 949-9610

TSC/ras

APPROVED	FIG.	
BY	CLASS	SUBCLASS
DRAFTSMAN		

5796183

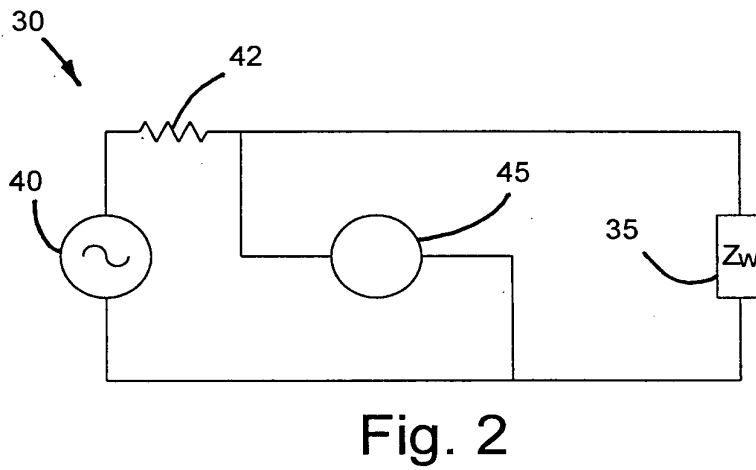
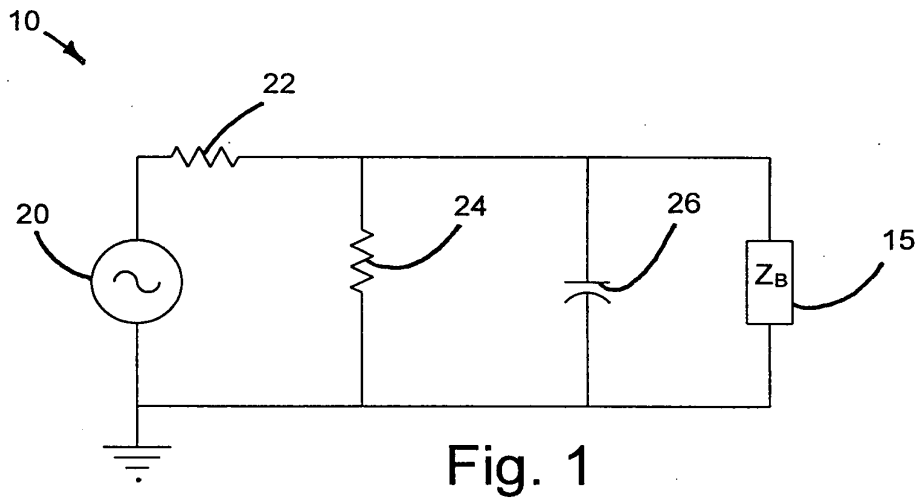

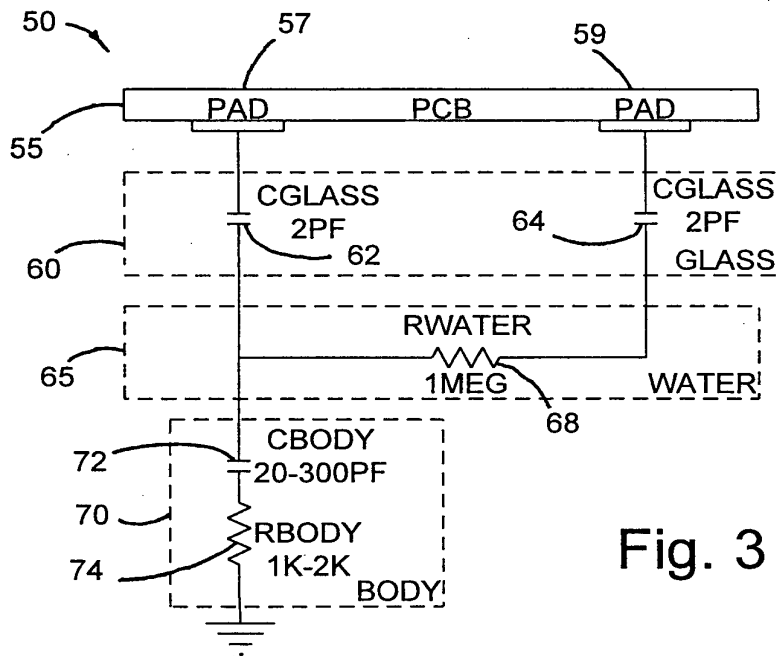

Fig. 3

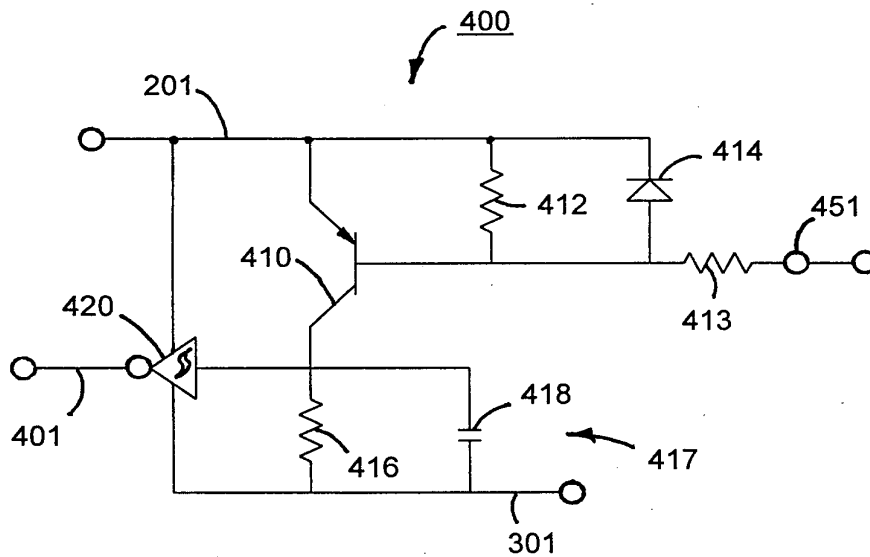

Fig. 8

APPROVED	BY FIG.	
BY	CLASS	SUBCLASS
DRAFTSMAN		

— ZGMIN
FREQUENCY

..... ZGMAX
FREQUENCY

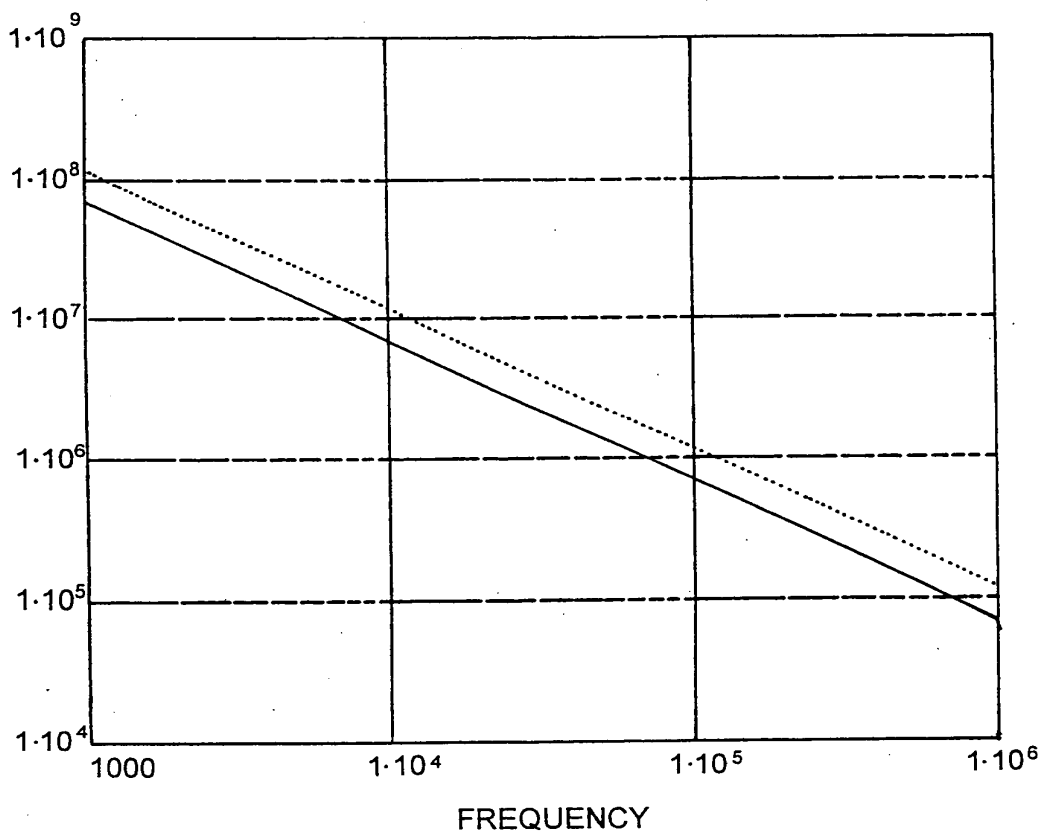

Fig. 3A

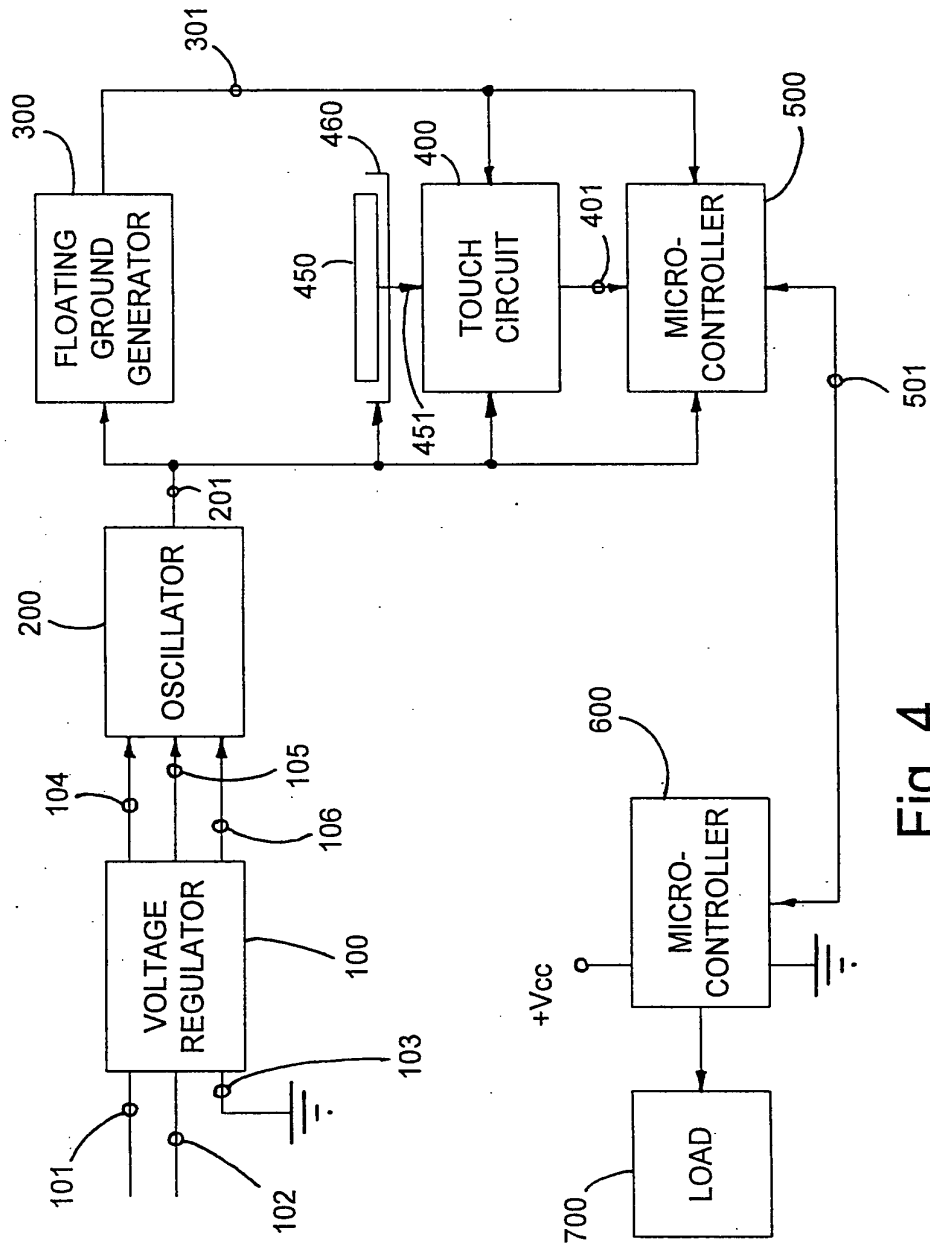

Fig. 4

APPROVED	BY	CLASS	FIG.
DRAFTSMAN		SUBCLASS	

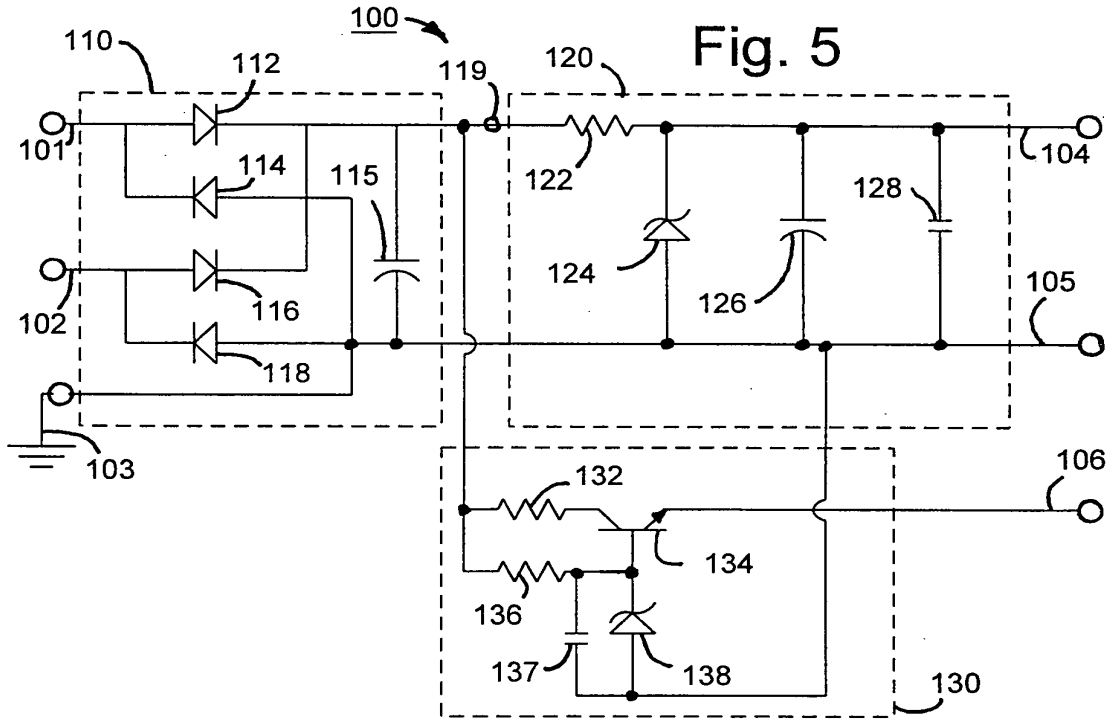

Fig. 5

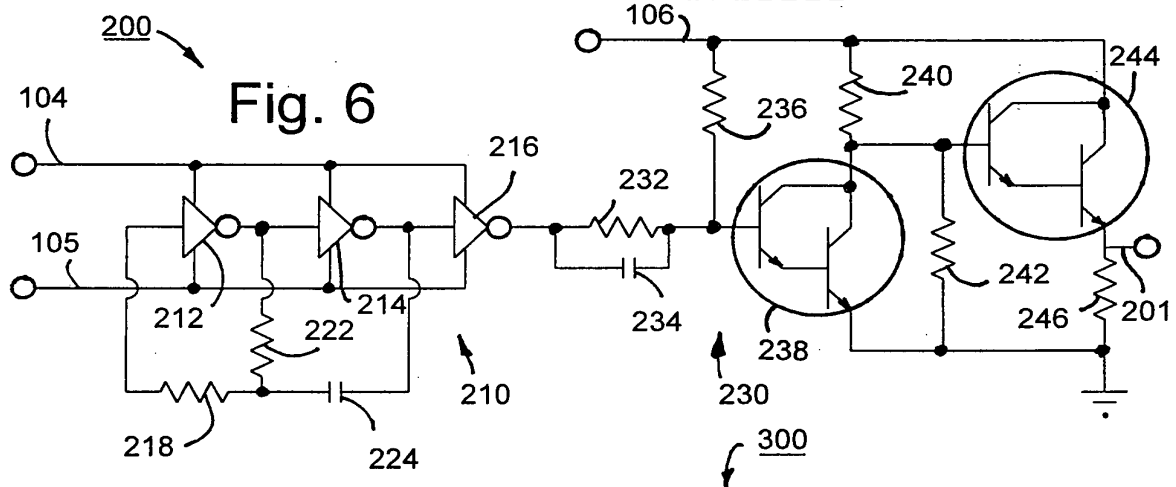

Fig. 6

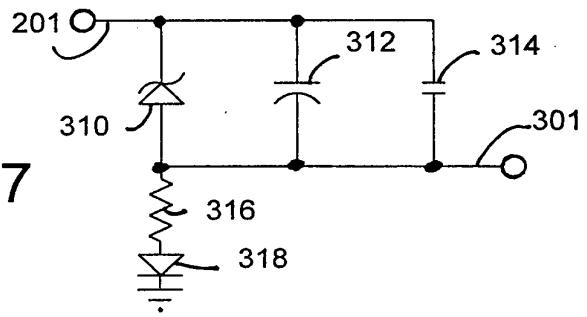

Fig. 7

APPROVED BY	DATE	FIG.
BY	CLASS	BUZCLASS
DRAFTSMAN		

S/N VS. BODY CAPACITANCE
TEMPERATURE = 105°C

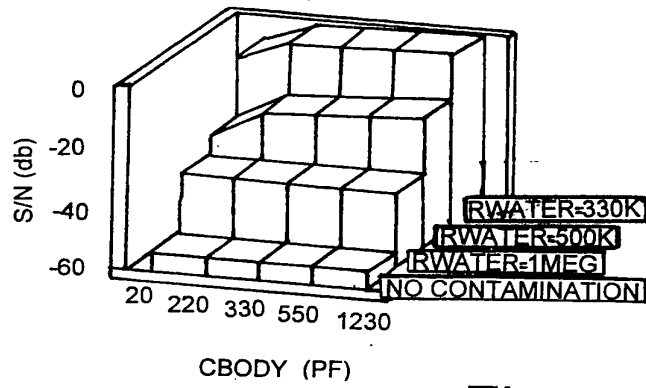

Fig. 9

S/N VS. BODY CAPACITANCE
TEMPERATURE = 25°C

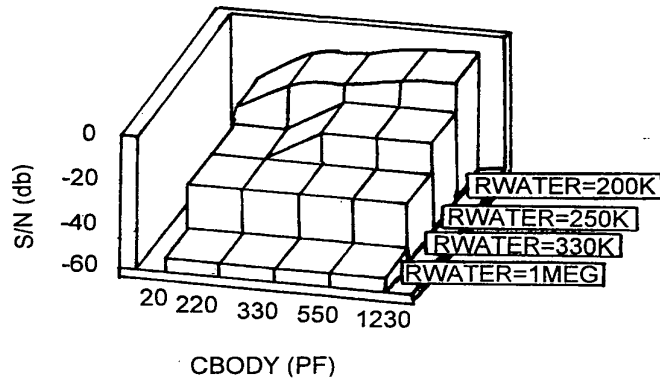
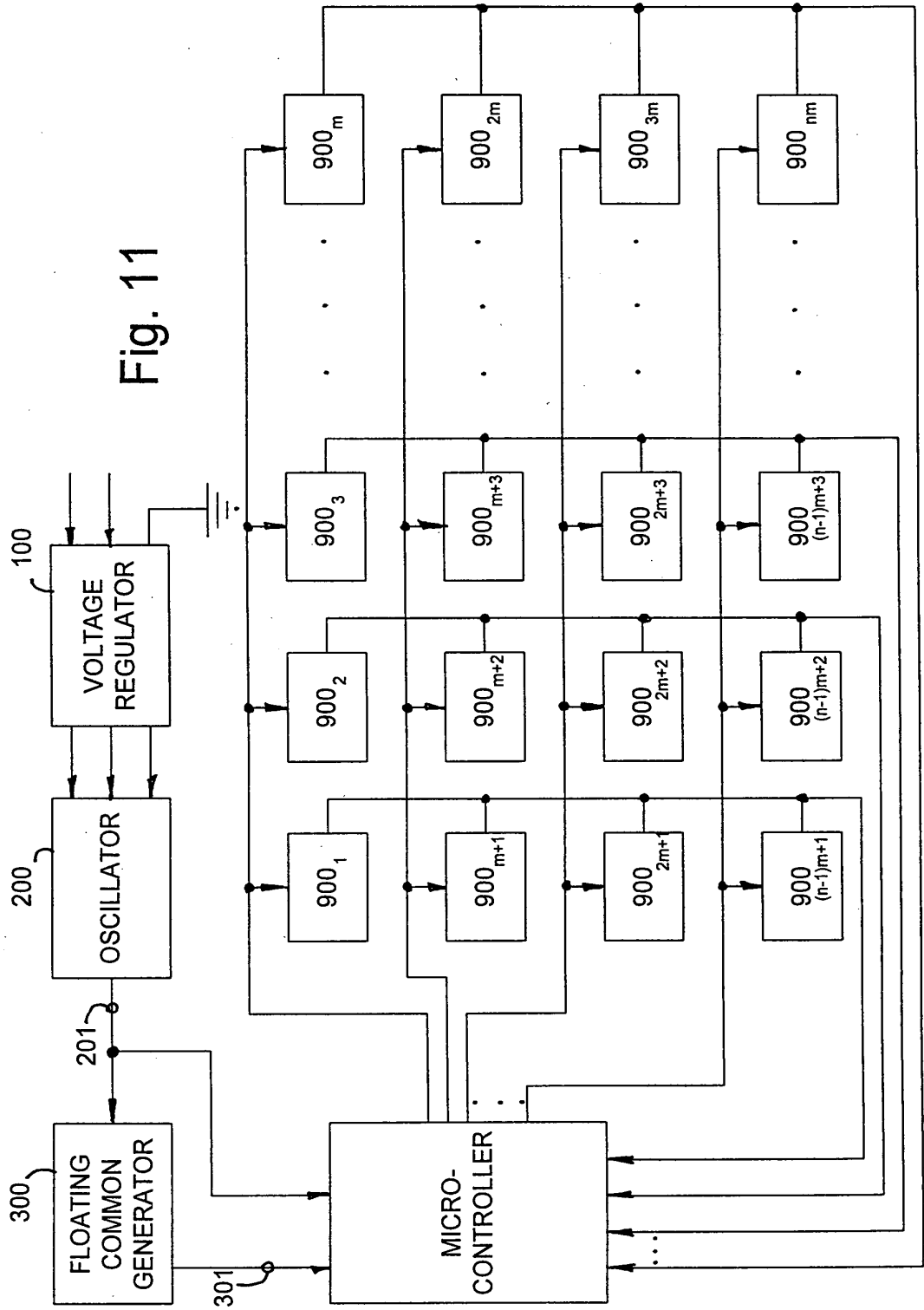

Fig. 10



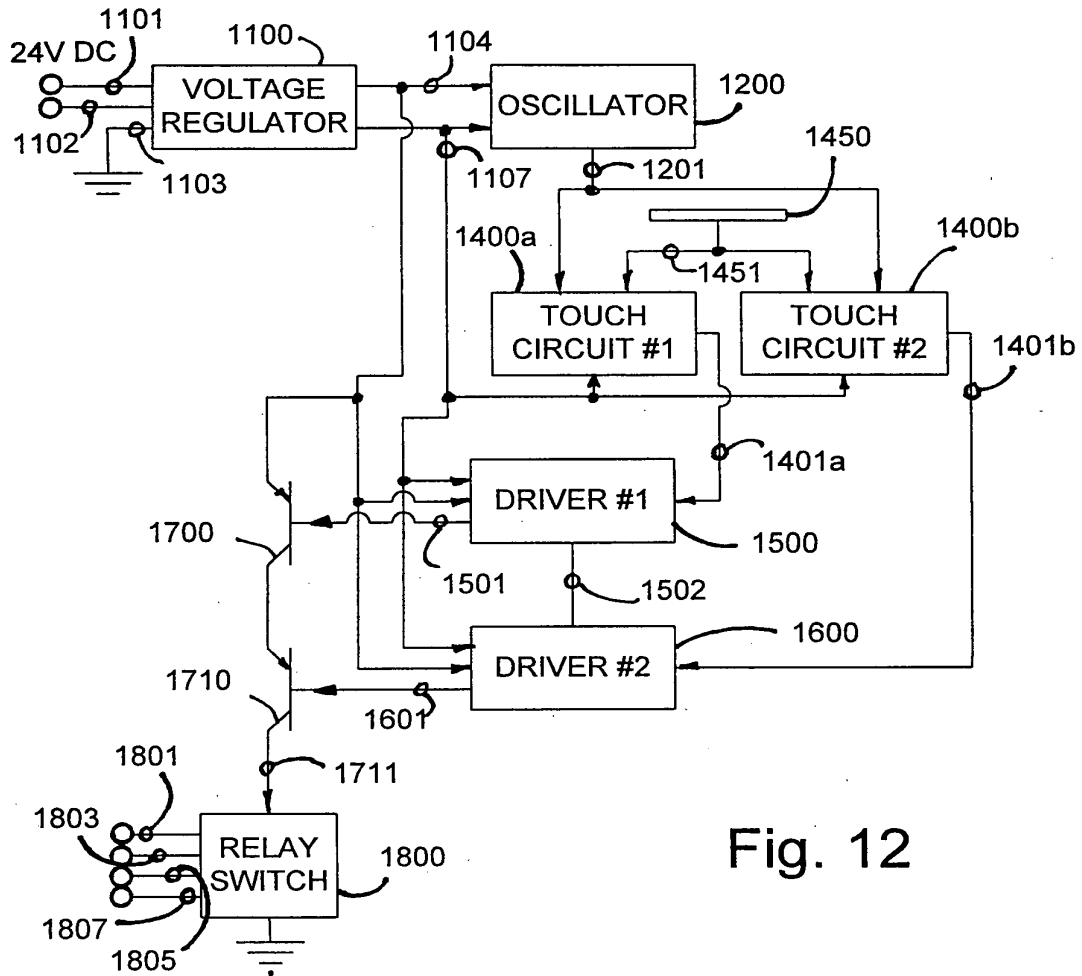

Fig. 12

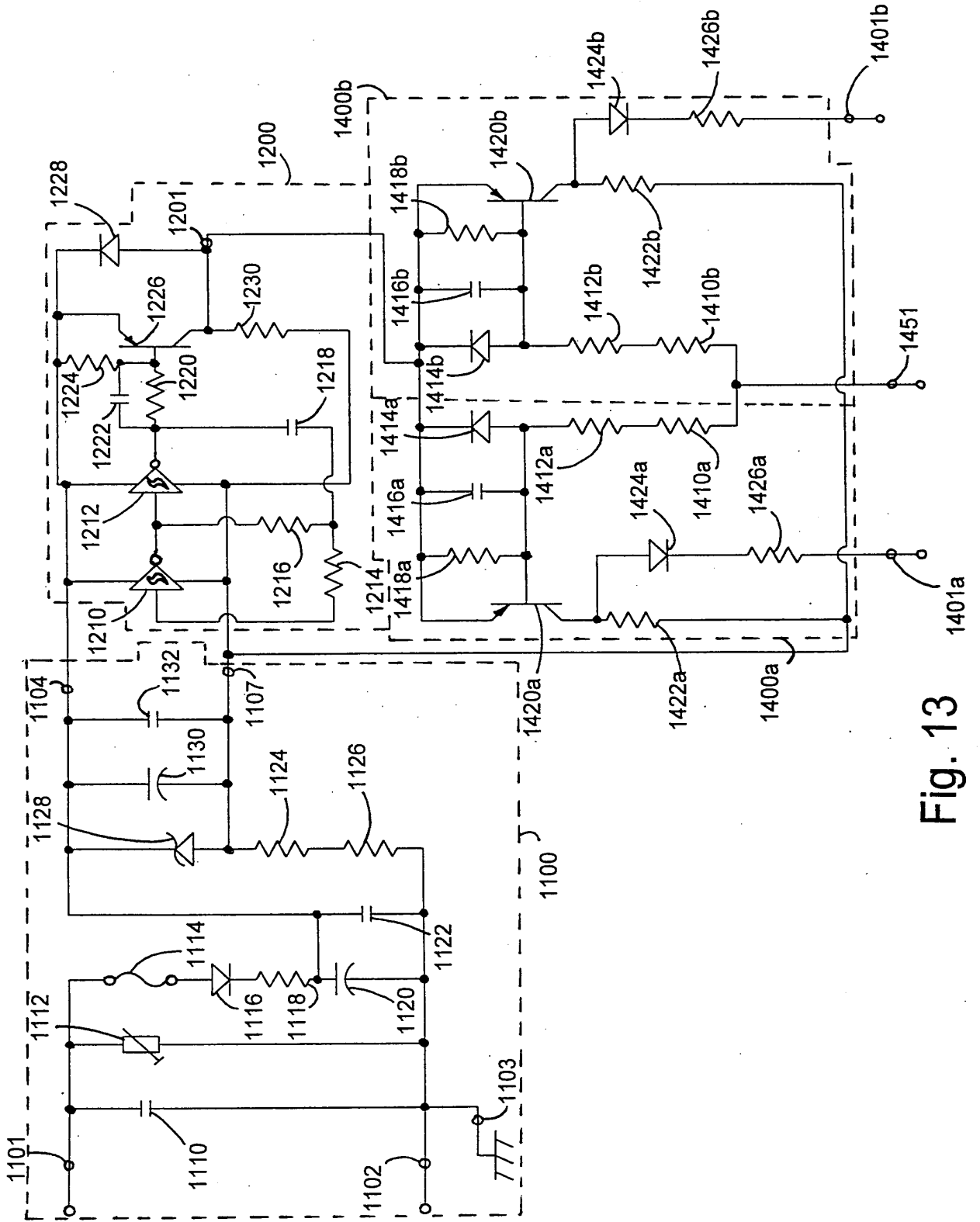

Fig. 13

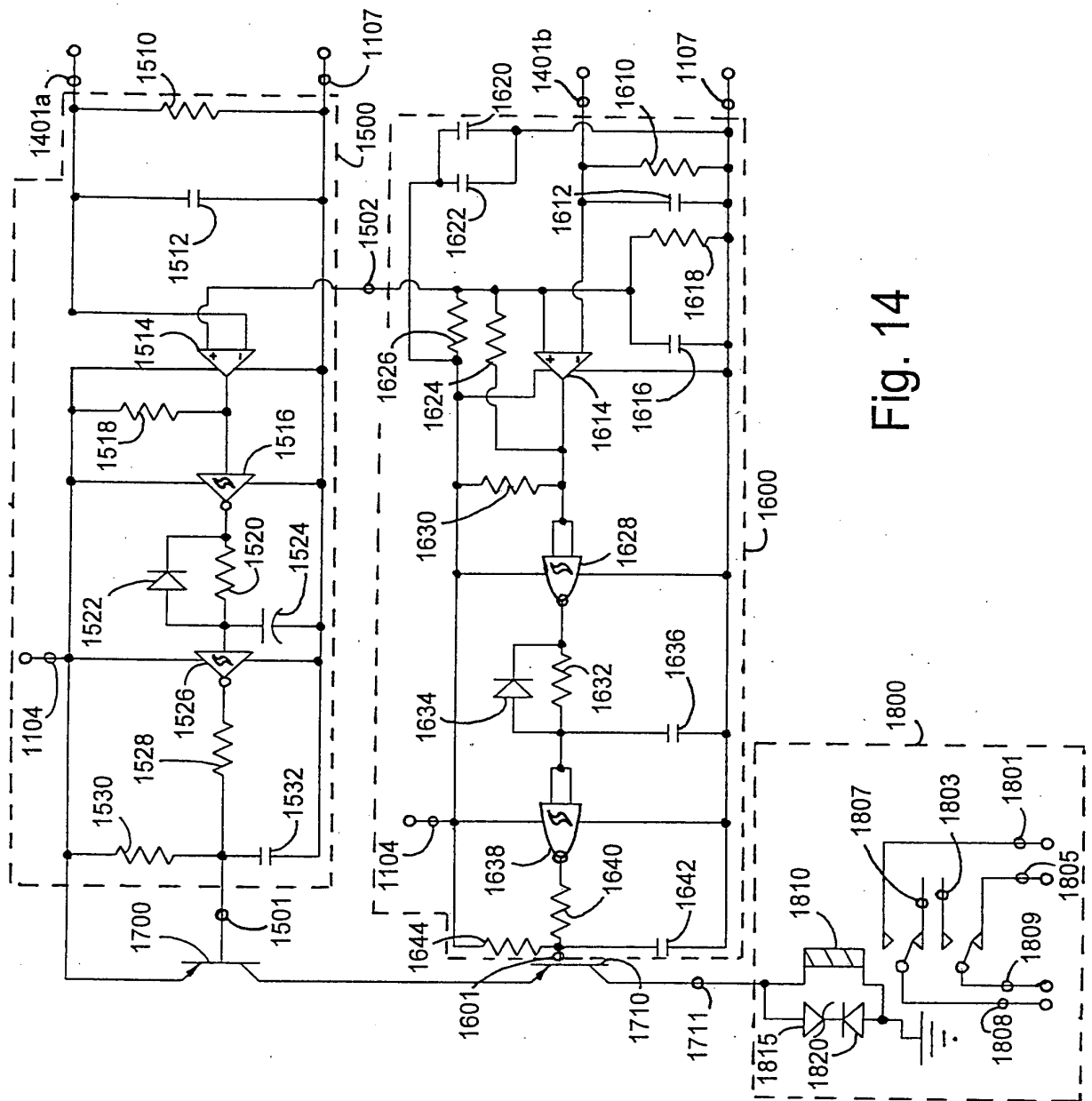

Fig. 14

APPROVED	DATE	
BY	CLASS	SUBCLASS
DRAFTSMAN		

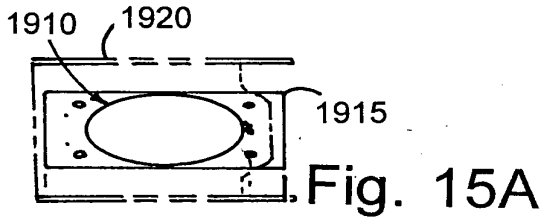

Fig. 15A

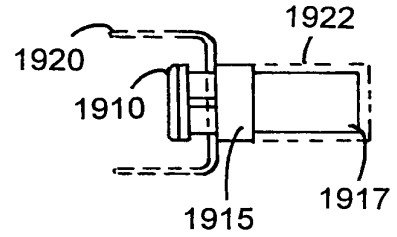

Fig. 15B

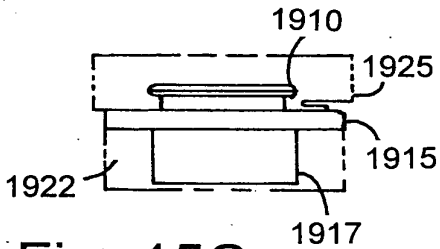

Fig. 15C

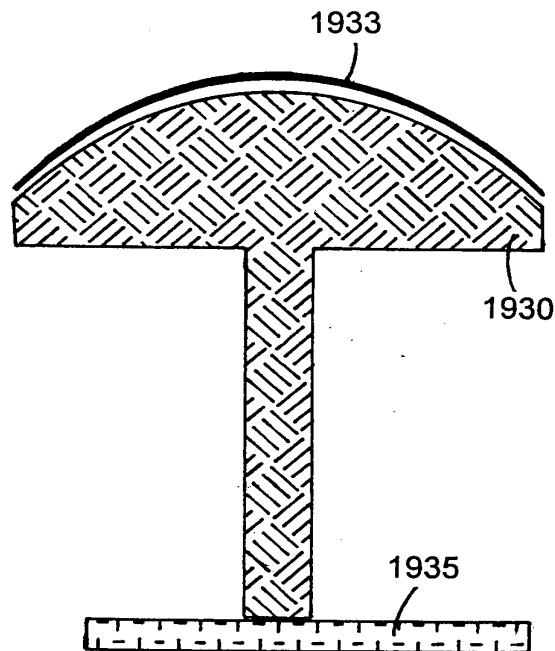

Fig. 16

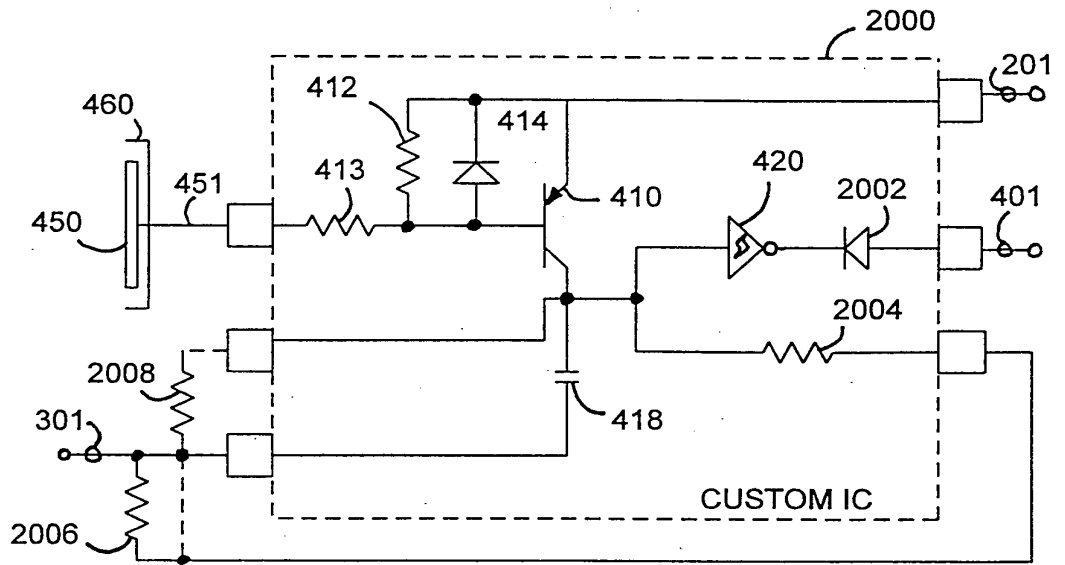

Fig. 17

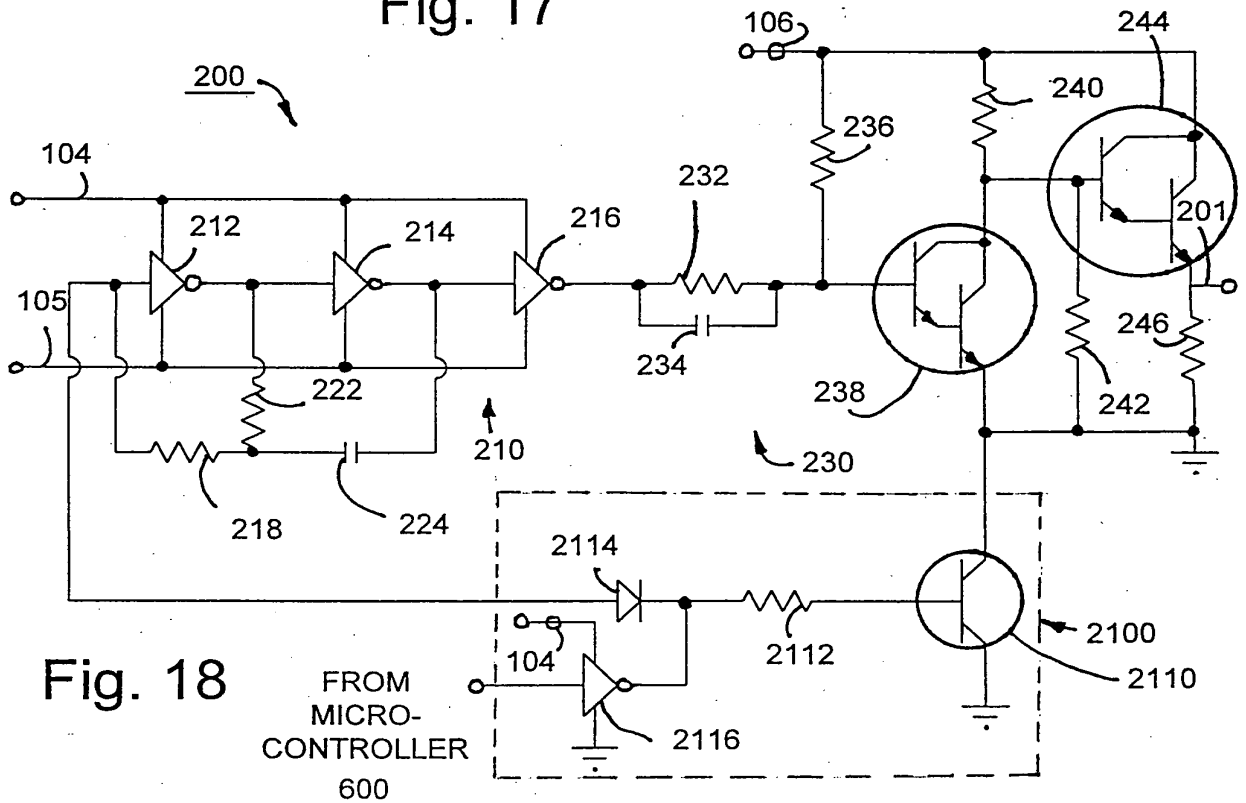

Fig. 18

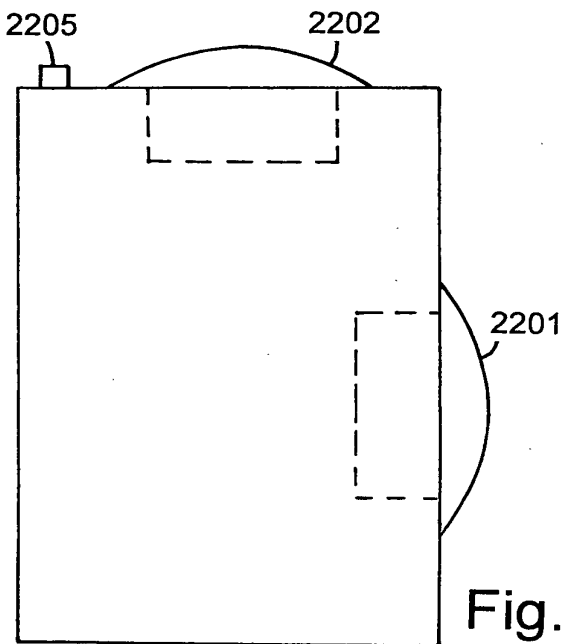

Fig. 19

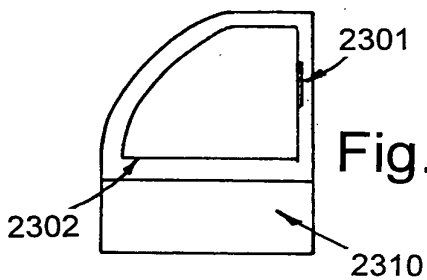

Fig. 20A

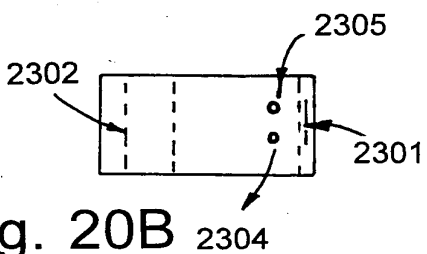

Fig. 20B

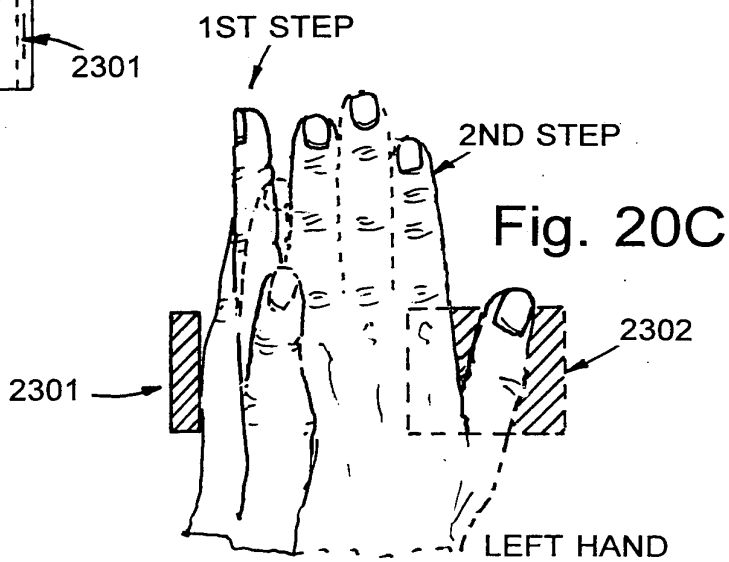

Fig. 20C

4100
 5796183
 4/12/98
 094
 3/1/10
 2811
 11/13
 6/2/98
 307/106.000

Atty. Docket No. NAR01 P-310

CERTIFICATE OF MAILING

I hereby certify that this paper, together with all enclosures identified herein, are being deposited with the United States Postal Service as first class mail, addressed to the Assistant Commissioner for Patents, Box Issue Fee, Washington D.C. 20231, on the date indicated below.

11/3/97
 Date

Rebecca A. Schwartz
 Rebecca A. Schwartz

IN THE UNITED STATES PATENT AND TRADEMARK OFFICE

Art Unit : 2107
 Examiner : J. Kaplan
 Appln. No. : 08/601,268
 Filing Date : January 31, 1996
 Applicant : Byron Hourmand
 For : CAPACTIVE RESPONSIVE ELECTRONIC SWITCHING CIRCUIT
 Batch No. : T51

NOV 06 1997
 RECEIVED
 Pub. Div.

Asst. Commissioner for Patents
 Box Issue Fee
 Washington, D.C. 20231

6-19-98
 7530 Pub. Div
 PN = 5,796,183

Dear Sir:

Entered b/c
 3G from BK
 10/14/98

AMENDMENT UNDER 37 C.F.R. §1.312

Pursuant to 37 C.F.R. §1.312 and subject to the recommendation of the Examiner and the approval of the Commissioner, and without withdrawing the case from issue, kindly amend the subject application as follows.

In the Claims:

Claim 27, line 11, after "when" delete "said".

REMARKS

The above-identified application was allowed in the Office Action mailed October 27, 1997. The issue fee has not been paid. Subsequent to the receipt of the Notice of

Applicant : Byron Hourmand
Appl. No. : 08/601,268
Page : 2

Allowance, Applicant noted a typographical error in claim 27. The requested amendment is submitted to correct this error. The requested amendment is fully supported by the specification and drawings, will not require an additional search, and does not raise new issues. Therefore, Applicant respectfully requests that this amendment be entered and the requested change made.

The reference for the application within the issue branch as indicated on the Notice of Allowance, is T51. If there are any fees due in connection with the filing of this amendment, please charge the fees to our deposit account No. 16 2463.

Respectfully submitted,

BYRON HOURMAND

By: Price, Heneveld, Cooper,
DeWitt & Litton

11-3-97
Date

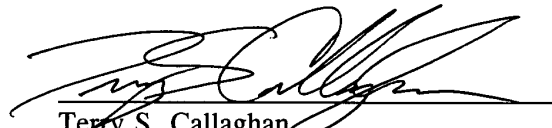
Terry S. Callaghan
Registration No. 34 559
695 Kenmoor, S.E.
Post Office Box 2567
Grand Rapids, Michigan 49501
(616) 949-9610

TSC/ras



UNITED STATES DEPARTMENT OF COMMERCE
Patent and Trademark Office

Address: Box ISSUE FEE
ASSISTANT COMMISSIONER FOR PATENTS
Washington, D.C. 20231

NOTICE OF ALLOWANCE AND ISSUE FEE DUE

21M1/1027

PRICE HENEVELD COOPER
DEWITT & LITTON
695 KENMOOR DRIVE SE
P O BOX 2567
GRAND RAPIDS MI 49501

12

APPLICATION NO.	FILING DATE	TOTAL CLAIMS	EXAMINER AND GROUP ART UNIT	DATE MAILED
08/601,268	01/31/96	032	KAPLAN, J	2107 10/27/97
First Named Applicant	HOURMAND, BYRON			

TITLE OF INVENTION CAPACITIVE RESPONSIVE ELECTRONIC SWITCHING CIRCUIT

ATTY'S DOCKET NO.	CLASS-SUBCLASS	BATCH NO.	APPLN. TYPE	SMALL ENTITY	FEE DUE	DATE DUE
2	NAR01-P-310	307-116.000	T51 UTILITY	YES	\$660.00	01/27/98

THE APPLICATION IDENTIFIED ABOVE HAS BEEN EXAMINED AND IS ALLOWED FOR ISSUANCE AS A PATENT. PROSECUTION ON THE MERITS IS CLOSED.

THE ISSUE FEE MUST BE PAID WITHIN THREE MONTHS FROM THE MAILING DATE OF THIS NOTICE OR THIS APPLICATION SHALL BE REGARDED AS ABANDONED. THIS STATUTORY PERIOD CANNOT BE EXTENDED.

HOW TO RESPOND TO THIS NOTICE:

- I. Review the SMALL ENTITY status shown above.
If the SMALL ENTITY is shown as YES, verify your current SMALL ENTITY status:
 - A. If the status is changed, pay twice the amount of the FEE DUE shown above and notify the Patent and Trademark Office of the change in status, or
 - B. If the status is the same, pay the FEE DUE shown above.

If the SMALL ENTITY is shown as NO:

- A. Pay FEE DUE shown above, or
- B. File verified statement of Small Entity Status before, or with, payment of 1/2 the FEE DUE shown above.

II. Part B of this notice should be completed and returned to the Patent and Trademark Office (PTO) with your ISSUE FEE. Even if the ISSUE FEE has already been paid by charge to deposit account, Part B should be completed and returned. If you are charging the ISSUE FEE to your deposit account, section "6b" of Part B should be completed.

III. All communications regarding this application must give application number and batch number. Please direct all communication prior to issuance to Box ISSUE FEE unless advised to the contrary.

IMPORTANT REMINDER: Patents issuing on applications filed on or after Dec. 12, 1980 may require payment of maintenance fees. It is patentee's responsibility to ensure timely payment of maintenance fees when due.

3. PATENT AND TRADEMARK OFFICE COPY

Notice of Allowability

Application No. 08/601,268	Applicant(s) Hourmand
Examiner Jonathan Kaplan	Group Art Unit 2107



All claims being allowable, PROSECUTION ON THE MERITS IS (OR REMAINS) CLOSED in this application. If not included herewith (or previously mailed), a Notice of Allowance and Issue Fee Due or other appropriate communication will be mailed in due course.

- This communication is responsive to the amendment filed 8/27/97.
- The allowed claim(s) is/are 1-32.
- The drawings filed on _____ are acceptable.
- Acknowledgement is made of a claim for foreign priority under 35 U.S.C. § 119(a)-(d).
 - All Some* None of the CERTIFIED copies of the priority documents have been received.
 - received in Application No. (Series Code/Serial Number) _____.
 - received in this national stage application from the International Bureau (PCT Rule 17.2(a)).
- *Certified copies not received: _____
- Acknowledgement is made of a claim for domestic priority under 35 U.S.C. § 119(e).

A SHORTENED STATUTORY PERIOD FOR RESPONSE to comply with the requirements noted below is set to EXPIRE **THREE MONTHS** FROM THE "DATE MAILED" of this Office action. Failure to timely comply will result in ABANDONMENT of this application. Extensions of time may be obtained under the provisions of 37 CFR 1.136(a).

- Note the attached EXAMINER'S AMENDMENT or NOTICE OF INFORMAL APPLICATION, PTO-152, which discloses that the oath or declaration is deficient. A SUBSTITUTE OATH OR DECLARATION IS REQUIRED.
- Applicant **MUST** submit **NEW FORMAL DRAWINGS**
 - because the originally filed drawings were declared by applicant to be informal.
 - including changes required by the Notice of Draftsperson's Patent Drawing Review, PTO-948, attached hereto or to Paper No. 8.
 - including changes required by the proposed drawing correction filed on 8/27/97, which has been approved by the examiner.
 - including changes required by the attached Examiner's Amendment/Comment.

Identifying indicia such as the application number (see 37 CFR 1.84(c)) should be written on the reverse side of the drawings. The drawings should be filed as a separate paper with a transmittal letter addressed to the Official Draftsperson.

- Note the attached Examiner's comment regarding REQUIREMENT FOR THE DEPOSIT OF BIOLOGICAL MATERIAL.

Any response to this letter should include, in the upper right hand corner, the APPLICATION NUMBER (SERIES CODE/SERIAL NUMBER). If applicant has received a Notice of Allowance and Issue Fee Due, the ISSUE BATCH NUMBER and DATE of the NOTICE OF ALLOWANCE should also be included.

Attachment(s)

- Notice of References Cited, PTO-892
- Information Disclosure Statement(s), PTO-1449, Paper No(s) 9
- Notice of Draftsperson's Patent Drawing Review, PTO-948
- Notice of Informal Patent Application, PTO-152
- Interview Summary, PTO-413
- Examiner's Amendment/Comment
- Examiner's Comment Regarding Requirement for Deposit of Biological Material
- Examiner's Statement of Reasons for Allowance

WILLIAM M. SHOOP, JR.
SUPERVISORY PATENT EXAMINER
ART UNIT 217



07/31/97

FORM PTO-1449 U.S. DEPARTMENT OF COMMERCE (Rev. 2-32) PATENT AND TRADEMARK OFFICE INFORMATION DISCLOSURE STATEMENT BY APPLICANT (Use several sheets if necessary)	ATTY. DOCKET NO. NAR01 P-310	SERIAL NO. 08/601,268
	APPLICANT(S) BYRON HOURMAND	
	FILING DATE 01/31/96	ART UNIT 2107

U.S. PATENT DOCUMENTS

EXAMINER INITIAL	DOCUMENT NUMBER	DATE	NAME	CLASS	SUB-CLASS	FILING DATE IF APPROPRIATE	
						Y	N
	5 5 7 2 2 0 5	11/05/96	Caldwell et al.	341	33		

FOREIGN PATENT DOCUMENTS

EXAMINER INITIAL	DOCUMENT NUMBER	DATE	COUNTRY	CLASS	SUB-CLASS	TRANSLATION	
						Y	N

OTHER DOCUMENTS (Including Author, Title, Date, Pertinent Pages, Etc.)

EXAMINER INITIAL	

EXAMINER <i>Jonathan Kaplan</i>	DATE CONSIDERED <i>10/24/97</i>
EXAMINER: Initial if citation considered, whether or not citation is in conformance with MPEP 609; Draw line through citation if not in conformance and not considered. Include copy of this form with next communication to applicant.	

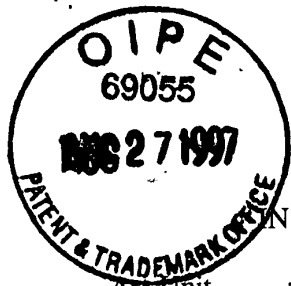

Atty. Docket No. NAR01 P-310

IN THE UNITED STATES PATENT AND TRADEMARK OFFICE

10

Art Unit : 2107
 Examiner : J. Kaplan
 Appln. No. : 08/601,268
 Filing Date : January 31, 1996
 Applicant : Byron Hourmand
 For : CAPACITIVE RESPONSIVE ELECTRONIC SWITCHING CIRCUIT

Assistant Commissioner for Patents
 Washington, D.C. 20231

RECEIVED
 SEP 22 1997
 GROUP 2100

Dear Sir:

AMENDMENT

This is a response to the Office Action mailed April 22, 1997. The time for filing a response to the Office Action has been extended by the petition for a one-month extension of time and payment of the appropriate fee filed concurrently with this amendment. Applicant requests that the Examiner amend the above-captioned application as follows.

In the Drawings:

Subject to the approval of the Examiner, please amend Figs. 1, 3, 4, 5, 11, 12, 13, 14, and 18 as shown in red on the attached sheets of drawings.

In the Specification:

Please amend the specification as follows:

- Page 1, line 9, change "movement" to --movements--.
- Page 2, line 17, after "is" insert --(are)--.
- Page 12, line 1, change "ground" to --common--.
- Page 12, line 5, change "approved" to --listed--.
- Page 12, line 9, change "ground" to --floating common--.
- Page 12, line 12, delete "true".

Applicant : Byron Hourmand
Appl. No. : 08/601,268
Page : 2

- ✓ Page 13, line 19, after "operator" insert --to--.
- ✓ Page 14, line 2, after "capacitance" insert --to ground--.
- ✓ Page 15, line 2, change "ground" to --common--.
- ✓ Page 17, line 9, change "an external" to --a--.
- ✓ Page 17, line 12, change "ZB" to --Z_B--.
- ✓ Page 18, line 11, change "ZW" to --Z_w--.
- ✓ Page 21, line 11, change "an external" to --a--.
- ✓ Page 21, line 16, change "it's" to --its--.
- ✓ Page 23, line 12, change "will" to --well--.
- ✓ Page 23, line 20, delete "preferably".
- ✓ Page 25, line 7, delete "relative to an external ground such as the earth".
- ✓ Page 26, line 4, change "ground" to --common--.
- ✓ Page 26, line 6, change "ground" to --common--.
- ✓ Page 26, line 7, change "ground" to --common--.
- ✓ Page 26, line 9, change "ground" to --common--.
- ✓ Page 26, line 10, change "ground" to --common-- (both occurrences).
- ✓ Page 26, line 12, change "ground" to --common--.
- ✓ Page 26, line 14, after "capacitance" insert --to ground--.
- ✓ Page 26, line 17, after "capacitance" insert --to ground--.
- ✓ Page 29, line 13, change "coupled" to --directly connected--.
- ✓ Page 29, line 14, change "coupled" to --directly connected--.

Applicant : Byron Hourmand
Appl. No. : 08/601,268
Page : 3

Page 29, line 14, delete "output of the".

Page 29, line 14, change "213" to --216--.

Page 30, line 8, after "between" insert --near to--.

Page 30, line 15, change "generate" to --the floating common generator 300 such that

a' together they supply a--.

Page 30, line 16, change "and powers up" to --to power--.

Page 30, line 16, change "circuits" to --circuit(s)--.

Page 31, line 4, change "must" to --can--.

Page 31, line 6, delete "and preferably".

Page 31, line 17, delete "between the".

Page 31, line 18, delete "collector of transistor 410 and floating ground line 301".

Page 32, line 11, after "includes" insert --resistor 412 and--.

Page 32, line 12, before "resistor" insert --to--.

Page 32, line 16, change "Resistor 413 is used to limit the base current." to --The

a2 base of transistor 410 is connected via resistor 413 to line 451 connected to touch pad 450.--.

Page 33, line 5, after "capacitance" insert --to ground--.

Page 33, line 11, after "capacitance" insert --to ground--.

Page 33, line 11, delete "earth".

Page 33, line 15, after "reverse" insert --bias--.

Page 33, line 15, change "thereby reducing" to --and also reduce--.

Page 40, line 11, after "length" insert --451--.

60

Applicant : Byron Hourmand
Appl. No. : 08/601,268
Page : 4

- ✓ Page 40, line 11, change "pad 451" to --pad 450--.
- ✓ Page 41, line 9, change "and an earth relative ground" to --with ground connection--.
- ✓ Page 41, line 10, after "1103," delete "and".
- ✓ Page 42, line 9, change "to relative earth ground 1103" to --via line 1103 to ground--.
- ✓ Page 42, line 17, change "power line" to --power common line--.
- ✓ Page 42, line 17, delete "relative".
- ✓ Page 44, line 8, change "a transistor" to --a bipolar PNP transistor--.
- ✓ Page 44, line 8, change "1420" to --1420a--.
- ✓ Page 44, line 9, change "power line" to --power common line--.
- ✓ Page 44, line 18, change "1424" to --1424a--.
- ✓ Page 45, line 2, change "power line" to --power common line--.
- ✓ Page 45, line 4, change "negative" to --inverting input--.
- ✓ Page 45, line 4, change "positive" to --non-inverting input--.
- ✓ Page 45, line 11, change "power line" to --power common line--.
- ✓ Page 45, line 12, after "base of" insert --bipolar PNP--.
- ✓ Page 45, line 13, change "power line" to --power common line--.
- ✓ Page 46, line 4, change "power line" to --power common line--.
- ✓ Page 46, line 5, change "negative" to --inverting input--.
- ✓ Page 46, line 6, change "positive" to --non-inverting input--.
- ✓ Page 46, line 7, change "positive" to --non-inverting input--.
- ✓ Page 46, line 8, change "power line" to --power common line--.

Applicant : Byron Hourmand
Appl. No. : 08/601,268
Page : 5

- Page 46, line 10, change "1639" to --1630--.
- Page 46, line 11, change "positive" to --non-inverting--.
- Page 46, line 12, change "invertor gate" to --invertor NAND gate--.
- Page 46, line 14, change "invertor gate" to --invertor NAND gate--.
- Page 46, line 15, change "invertor gate" to --invertor NAND gate-- (both occurrences).
- Page 46, line 15, change "power line" to --power common line--.
- Page 46, line 16, after "switching" insert --bipolar PNP--.
- Page 46, line 17, change "power line" to --power common line--.
- Page 47, line 15, change "(1628)" to --(invertor NAND gate 1628)--.
- Page 47, line 17, change "(1536)" to --(1636)--.
- Page 47, line 18, after "when" insert --the--.
- Page 47, line 19, change "button" to --touch terminal--.
- Page 48, line 15, after "one" insert --of the touch switch circuits--.
- Page 48, line 15, after "redundant" insert --relay driver--.
- Page 48, line 16, after "one" insert --of the driver circuits--.
- Page 48, line 20, change "2201" to --2205. Palm button 2201--.
- Page 49, line 1, delete "second" (first occurrence).
- Page 50, line 6, change "sid" to --side--.
- Page 51, line 4, after "smaller" insert --series--.
- Page 51, line 6, after "body" insert --to ground-- (both occurrences).

Applicant : Byron Hourmand
Appl. No. : 08/601,268
Page : 6

Page 51, line 8, after "capacitance" insert --to ground--.

Page 51, line 10, change "earth" to --ground--.

Page 53, line 1, change "decrease and increase" to --adjust--.

Page 53, line 2, delete "respectively".

Page 53, line 5, after "200" insert --(Fig. 6)-- (first occurrence).

Page 53, line 10, change "pulls" to --sources--.

In the Abstract:

Please amend the abstract as follows:

Line 6, before "touch" insert --proximity and--.

Line 9, after "capacitance" insert --to ground--.

Line 9, after "when" insert --in proximity or--.

In the Claims:

Please amend claims 1, 3, 5, 6, 12-18, and 20, and add new claims 21-32 as follows:

1. (Amended) A capacitive responsive electronic switching circuit comprising:

an oscillator providing a periodic output signal having a frequency of 50 kHz or greater;

an input touch terminal having a dielectric cover defining an area for an operator to provide an input by proximity and touch, an operator's body capacitance to ground as sensed through said input touch terminal varying as a function of the area of said input touch terminal that is proximate the operator's body; and

Applicant : Byron Hourmand
Appl. No. : 08/601,268
Page : 7

03
cmd

a detector circuit coupled to said oscillator for receiving said periodic output signal from said oscillator, and coupled to said input touch terminal, said detector circuit being responsive to signals from said oscillator and the presence of an operator's body capacitance to ground coupled to said touch terminal when proximal or touched by an operator to provide a control output signal, wherein said detector circuit includes means for generating said control signal when the sensed body capacitance to ground exceeds a threshold level in order to prevent unintended activation based upon an operator's inadvertent proximity and touch with said input touch terminal.

[\

Claim 3, line 2, delete "reference to an external".

04

9. ~~5~~ (Amended) A capacitive responsive electronic [The] switching circuit [as defined in claim 1 and further including] comprising:

an oscillator providing a periodic output signal having a frequency of 50 kHz or greater;

an input touch terminal defining an area for an operator to provide an input by proximity and touch;

a detector circuit coupled to said oscillator for receiving said periodic output signal from said oscillator, and coupled to said input touch terminal, said detector circuit being responsive to signals from said oscillator and the presence of an operator's body capacitance

Applicant : Byron Hourmand
Appl. No. : 08/601,268
Page : 8

to ground coupled to said touch terminal when proximal or touched by an operator to provide a control output signal; and

a floating [ground] common generator coupled to said oscillator for receiving said square wave output signal, said floating [ground] common generator generating a floating [ground] common reference for said detector circuit that is set at a fixed voltage below and tracks the square wave output signal.

10. ~~6.~~ (Amended) The switching circuit as defined in claim ~~5~~⁹, wherein said detector circuit is powered by said square wave output signal provided by said oscillator and by said floating [ground] common reference provided by said floating [ground] common generator [to increase] thereby increasing the sensitivity of said detector circuit to proximity and touching of said touch terminal by an operator's body.

12. (Amended) A proximity and touch controlled switching circuit comprising:

an oscillator providing a square wave output signal having a frequency of 50 kHz or greater;

a touch terminal having a dielectric cover defining an input terminal for coupling to an operator's body capacitance to ground; and

a charge pump circuit coupled to said oscillator for receiving said square wave output signal, and coupled to said touch terminal, said charge pump circuit having an output terminal that supplies an output signal having a voltage that varies when said touch terminal

Applicant : Byron Hourmand
Appl. No. : 08/601,268
Page : 9

is proximal or touched by an operator's body, the voltage of said output signal varies as a function of the area of said touch terminal that is proximal or touched by an operator,

wherein said charge pump circuit includes at least one high speed diode coupled between said oscillator and said touch terminal, for enhancing a sensitivity at which said charge pump responds to sensed body capacitance to ground at said touch terminal for higher frequencies.

A5
cond.

13. (Amended) The [touch control] proximity and touch controlled circuit as defined in claim 12 and further including a DC power supply for supplying power to said oscillator and a [reference to an external] ground.

[

Claim 14, line 1, change "touch control" to --proximity and touch controlled--.

16.

~~15.~~ (Amended) A proximity and [The] touch [control] controlled switching circuit [as defined in claim 12 and further including] comprising:

an oscillator providing a square wave output signal having a frequency of 50 kHz or greater;

a touch terminal defining an input terminal for coupling to an operator's body capacitance to ground;

a charge pump circuit coupled to said oscillator for receiving said square wave output signal, and coupled to said touch terminal, said charge pump circuit having an output

A6

64

Applicant : Byron Hourmand
Appl. No. : 08/601,268
Page : 10

terminal that supplies an output signal having a voltage that varies when said touch terminal is proximal or touched by an operator's body; and

a floating [ground] common generator coupled to said oscillator for receiving said square wave output signal, said floating [ground] common generator generating a floating [ground] common reference for said charge pump circuit that is set at a fixed voltage below and tracks said square wave output signal,

wherein said charge pump circuit includes at least one high speed diode coupled between said oscillator and said touch terminal, for enhancing a sensitivity at which said charge pump responds to sensed body capacitance to ground at said touch terminal for higher frequencies.

Ab
omit.

17.
~~16.~~ (Amended) The proximity and touch [control] controlled circuit as defined in claim ~~15~~¹⁶, wherein said charge pump circuit is powered by said square wave output signal provided by said oscillator and by said floating [ground] common reference provided by said floating [ground] common generator [to increase] thereby increasing the sensitivity of said charge pump circuit to proximity and touching of said touch terminal by an operator's body.

[

Claim 17, line 1, change " touch control" to --proximity and touch controlled--.

65

Applicant : Byron Hourmand
Appln. No. : 08/601,268
Page : 11

18. (Amended) A capacitive responsive electronic switching circuit comprising:

an oscillator providing a periodic output signal having a predefined frequency;

a plurality of input touch terminals defining adjacent areas on a dielectric substrate for an operator to provide inputs by proximity and touch; and

AS
a detector circuit coupled to said oscillator for receiving said periodic output signal from said oscillator, and coupled to said input touch terminals, said detector circuit being responsive to signals from said oscillator and the presence of an operator's body capacitance to ground coupled said touch terminals when proximal or touched by an operator to provide a control output signal,

wherein said predefined frequency of said oscillator is selected to decrease the impedance of said dielectric substrate relative to the impedance of any contaminate that may create an electrical on said dielectric substrate path between said adjacent areas, and wherein said detector circuit compares the sensed body capacitance to ground proximate an input touch terminal to a threshold level to prevent inadvertent generation of the control output signal.

20. (Amended) A capacitive responsive electronic switching circuit comprising:

AS
an oscillator providing a periodic output signal having a predefined frequency;

a dome-shaped touch terminal defining an area for an operator to provide an input by proximity and touch, wherein the dome shape of the touch terminal is constructed to ergonomically fit the palm of a human hand; and

Applicant : Byron Hourmand
Appl. No. : 08/601,268
Page : 12

AG
comment

a detector circuit coupled to said oscillator for receiving said periodic output signal from said oscillator, and coupled to said [input] touch terminal [terminals], said detector circuit being responsive to signals from said oscillator and the presence of an operator's body capacitance to ground coupled to said touch [terminals] terminal when proximal or touched by an operator to provide a control output signal, said detector circuit including means for discriminating between a proximity and touch of said dome-shaped touch terminal by the palm of a human hand and a proximity and touch by a human finger.

21. (New) A capacitive responsive electronic switching circuit comprising:

an oscillator providing a periodic output signal having a predefined frequency;

a touch terminal defining an area for an operator to provide an input by proximity and touch; and

a

a detector circuit coupled to said oscillator for receiving said periodic output signal from said oscillator, and coupled to said touch terminal, said detector circuit being responsive to signals from said oscillator and the presence of an operator's body capacitance to ground coupled to said touch terminal when proximal or touched by an operator to provide a control output signal, said detector circuit including discriminating means for discriminating between a proximity and touch of said touch terminal covering substantially all of said area of said touch terminal and a proximity and touch covering less than substantially all of said area of said touch terminal.

Applicant : Byron Hourmand
Appl. No. : 08/601,268
Page : 13

22. (New) The switching circuit as defined in claim 21, wherein said touch terminal includes a dome-shaped dielectric cover.

23. (New) The switching circuit as defined in claim 21, wherein said touch terminal includes a palm-sized dielectric cover.

24. (New) The switching circuit as defined in claim 23, wherein said discriminating means determines that a proximity and touch of said touch terminal covers substantially all of said area of said touch terminal when said dielectric cover is proximal or touched with the palm of an operator's hand and determines that a proximity or touch covers less than substantially all of said area of said touch terminal when said dielectric cover is proximal or touched with one of an operator's fingers.

25. (New) The switching circuit as defined in claim 21, wherein said discriminating means discriminates between a proximity and touch of said touch terminal covering substantially all of said area of said touch terminal and a proximity and touch covering less than substantially all of said area of said touch terminal based upon a sensed level of body capacitance to ground proximate said touch terminal.

CG
Comit.

W8

Applicant : Byron Hourmand
Appl. No. : 08/601,268
Page : 14

26. (New) The switching circuit as defined in claim 21, wherein said coupling of capacitance to ground occurs when an operator's body is proximate, but not touching, said touch terminal.

27. (New) A capacitive responsive electronic switching circuit for a controlled device comprising:

an oscillator providing a periodic output signal having a predefined frequency;
first and second touch terminals defining areas for an operator to provide an input by proximity and touch; and

a detector circuit coupled to said oscillator for receiving said periodic output signal from said oscillator, and coupled to said first and second touch terminals, said detector circuit being responsive to signals from said oscillator and the presence of an operator's body capacitance to ground coupled to said first and second touch terminals when proximal or touched by an operator to provide a control output signal for actuation of the controlled device, said detector circuit being configured to generate said control output signal when said an operator is proximal or touches said second touch terminal after the operator is proximal or touches said first touch terminal.

28. (New) The capacitive responsive electronic switching circuit as defined in claim 27, wherein said detector circuit generates said control signal only when an operator is proximal

69
Cont.

✓

69

Applicant : Byron Hourmand
Appl. No. : 08/601,268
Page : 15

or touches said second touch terminal within a predetermined time period after the operator is proximal or touches said first touch terminal.

29. (New) The capacitive responsive electronic switching circuit as defined in claim 27, wherein said first and second touch terminals are adapted to be mounted on different surfaces of the controlled device.

29
Cont.

30. (New) The capacitive responsive electronic switching circuit as defined in claim 27, wherein said first and second touch terminals are adapted to be mounted on non-parallel planar surfaces of the controlled device.

31. (New) The capacitive responsive electronic switching circuit as defined in claim 27, wherein said first and second touch terminals are adapted to be mounted on perpendicular planar surfaces of the controlled device.

32. (New) The capacitive responsive electronic switching circuit as defined in claim 27 and further including an indicator for indicating when said detector circuit determines that an operator is proximal or touches said first touch terminal.

Applicant : Byron Hourmand
Appl. No. : 08/601,268
Page : 16

REMARKS

In the Office Action, the Examiner indicated that claims 5 and 15 would be allowed if rewritten in independent form including all the limitations of the base claim and any intervening claims, and that claims 6, 7, and 16 would also be allowed if rewritten to overcome the rejection under 35 U.S.C. §112. Applicant wishes to thank the Examiner for the early indication of allowable subject matter. By this amendment, Applicant has amended claims 5 and 15 by rewriting them in independent form and by amending claims 6 and 16 to overcome the rejection under 35 U.S.C. §112. Therefore, claims 5-7, 15, and 16 are in condition for allowance.

In the Office Action, the Examiner rejected claims 6, 7, and 16 under 35 U.S.C. §112, second paragraph; rejected claims 1-4 and 12-14 under 35 U.S.C. §102(b) as being anticipated by U.S. Patent No. 4,352,141 issued to Kent; rejected claims 8-11, 18, and 19 under 35 U.S.C. §103 as being unpatentable over Kent in view of U.S. Patent No. 5,087,825 issued to Ingraham; and rejected claims 8-11, 18, and 19 under 35 U.S.C. §103 as being unpatentable over Kent in view of U.S. Patent No. 5,235,217 issued to Kirton.

By this amendment, Applicant has amended claims 1, 5, 6, 12-18, and 20 to more clearly define the present invention, and has added new claims 21-32 to define additional features of the present invention. Accordingly, claims 1-32 are now pending.

With respect to the rejection of claims 6, 7, and 16 under 35 U.S.C. §112, second paragraph, Applicant has amended claims 6 and 16 to more clearly recite the present

Applicant : Byron Hourmand
Appl. No. : 08/601,268
Page : 17

invention. Applicant submits that amended claims 6, 7, and 16 meet the requirements of 35 U.S.C. §112, second paragraph.

Applicant respectfully traverses the rejection of claims 1-4 and 12-14 under 35 U.S.C. §102(b) as being anticipated by Kent. As pointed out on page 51 of the present specification, the present invention provides a mechanism by which the touch control circuit can discriminate between an intentional touching of the touch terminal and an inadvertent contact by the operator. Specifically, when the touch terminal is palm-sized and includes a dielectric cover, users may intentionally touch the touch terminal by placing their palm over the entire surface of the touch terminal. When the operator touches the touch terminal in this manner, the touch control circuit of the present invention generates a control signal. On the other hand, if the operator inadvertently touches the touch terminal with one or two fingers, the touch control circuit of the present invention senses a lower body capacitance in the proximity of the touch terminal and thereby determines that the touch was unintentional and thus does not generate the control signal.

As amended, independent claim 1 recites a capacitive response electronic switching circuit comprising a combination of elements including at least "an input touch terminal having a dielectric cover defining an area for an operator to provide an input by touch, an operator's body capacitance as sensed through said input touch terminal varying as a function of the area of said input touch terminal that is proximate the operator's body," and a detector circuit that "includes means for generating said control signal when the sensed body

Applicant : Byron Hourmand
Appln. No. : 08/601,268
Page : 18

capacitance exceeds a threshold level in order to prevent unintended activation based upon an operator's inadvertent contact with said input touch terminal."

The Kent patent discloses a touch switch device that also generates the control signal in response to the touching of a touch terminal. The Kent patent, however, fails to teach or suggest a capacitive responsive electronic switching circuit having a detector circuit that includes means for generating a control signal when the sensed body capacitance exceeds a threshold level in order to prevent unintended activation based upon an operator's inadvertent contact with the input touch terminal. Thus, the Kent patent does not anticipate nor render obvious the invention as defined in independent claim 1. Clearly, the Kent patent does not disclose any way of discriminating between a partial touch and a full touch of the touch terminal.

With respect to independent claim 12, the Kent patent fails to teach or suggest a touch-controlled switching circuit comprising a charge pump circuit that supplies an output signal having a voltage that varies as a function of the area of the touch terminal that is touched by an operator. Therefore, the Kent patent fails to teach or suggest each and every element recited in independent claim 12.

For these reasons, independent claims 1 and 12, as well as claims 2-4, 13, and 14 which depend therefrom, are allowable over the Kent patent.

Applicant respectfully traverses the rejection of claims 8-11, 18, and 19 under 35 U.S.C. §103 as being unpatentable over Kent in view of Ingraham. Like the Kent patent, the Ingraham patent, which is assigned to the assignee of the present invention, fails to teach

Applicant : Byron Hourmand
Appl. No. : 08/601,268
Page : 19

or suggest a touch control circuit that discriminates between a full intentional contact with a touch terminal and an inadvertent partial contact of the same touch terminal. Therefore, the combination of the Kent and Ingraham patents fails to teach or suggest each and every element recited in independent claim 1. For this reason claims 8-11, which depend from independent claim 1, are allowable over the combination of the Kent and Ingraham patents.

With respect to independent claim 18, the Kent and Ingraham patents both fail to teach or suggest a capacitive responsive electronic switching circuit comprising a detector circuit that compares the sensed body capacitance proximate an input touch terminal to a threshold level in order to prevent inadvertent generation of a control output signal. For these reasons, Applicant submits that independent claims 1 and 18, as well as claims 8-11 and 19 which depend therefrom, are allowable over the Kent and Ingraham patents whether considered separately or in combination.

Applicant respectfully traverses the rejection of claims 8-11, 18, and 19 under 35 U.S.C. §103 as being unpatentable over Kent in view of Kirton. The Kirton patent, like the Kent and Ingraham patents, does not disclose a touch control circuit that is capable of discriminating between a full intentional touch of a touch terminal and an inadvertent touch of a portion of the surface of the touch terminal. For these reasons, independent claims 1 and 18, as well as claims 8-11 and 19 which depend therefrom, are allowable over the teachings of the Kent and Kirton patents whether considered separately or in combination.

It is noted that the Examiner has not rejected claims 17 and 20 in the Office Action. Claim 17 depends from independent claim 12 and is believed to be allowable for the reasons

Applicant : Byron Hourmand
Appln. No. : 08/601,268
Page : 20

discussed above with respect to claim 12. Independent claim 20 recites a dome-shaped touch terminal. By this amendment, Applicant has amended independent claim 20 to recite that the detector circuit includes means for discriminating between a touch of the dome-shaped touch terminal by the palm of a human hand and a touch by a human finger. For the reasons stated above with respect to independent claims 1, 12, and 18, Applicant submits that independent claim 20 is allowable over the combined teachings of the Kent, Ingraham, and Kirton patents.

In this amendment, Applicant has presented new independent claim 21, and claims 22-26 which depend therefrom. New independent claim 21 defines a capacitive responsive electronic switching circuit comprising at least a detector circuit "including discriminating means for discriminating between the touch of said touch terminal covering substantially all of said area of said touch terminal and a touch covering less than substantially all of said area of said touch terminal. For the reasons discussed above with respect to the other independent claims, Applicants submit that neither the Kent, Ingraham, nor Kirton patents teach or suggest the touch control circuit including a detector circuit having such discriminating means. Therefore, new independent claim 21 as well as claims 22-26 are allowable over the references cited of record.

New independent claim 27 recites a switching circuit for a control device that comprises at least first and second touch terminals and a detector circuit that generates a control output signal for actuation of the control device when an operator is proximal or touches the second touch terminal after the operator is proximal or touches the first touch

Applicant : Byron Hourmand
Appl. No. : 08/601,268
Page : 21

terminal. Dependent claim 28 recites that the detector circuit generates the control signal only when the second touch terminal is actuated within a predetermined time period after the actuation of the first touch terminal. Applicant submits that none of the cited references teaches or suggests such features. New claims 29-32 depend from new independent claim 27 and are believed to be allowable for the same reasons stated above with respect to independent claim 27.

In view of the foregoing amendments and remarks, Applicant submits that the present invention as defined in the pending claims, is allowable over the prior art of record. The Examiner's reconsideration and timely allowance of the claims are requested. A Notice of Allowance is therefore respectfully solicited.

Respectfully submitted,

BYRON HOURMAND

By: Price, Heneveld, Cooper,
DeWitt & Litton

8-22-97
Date

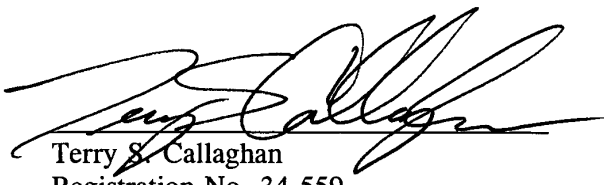
Terry S. Callaghan
Registration No. 34 559
695 Kenmoor, S.E.
Post Office Box 2567
Grand Rapids, Michigan 49501
(616) 949-9610

TSC/ras

Att #10

OK to enter
D/K 10/24/87

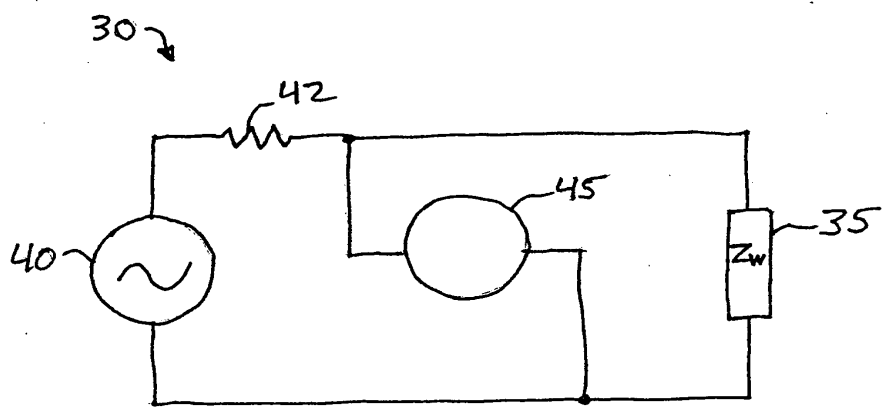
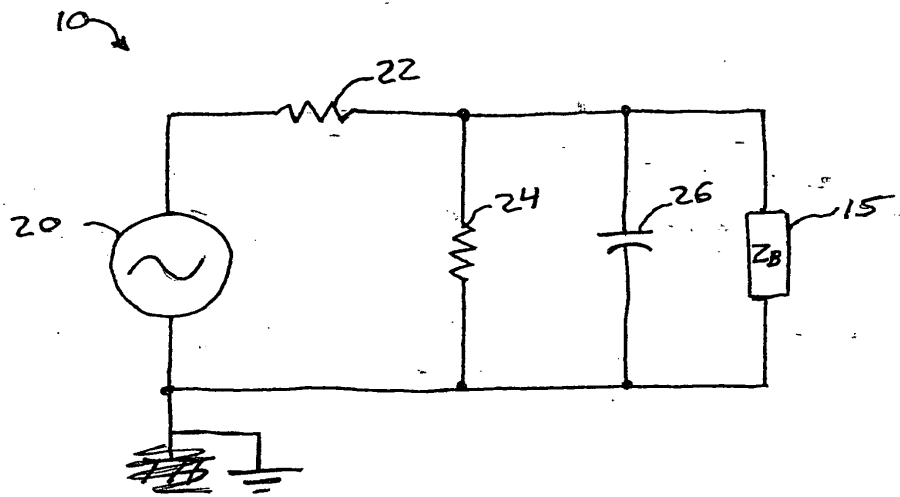

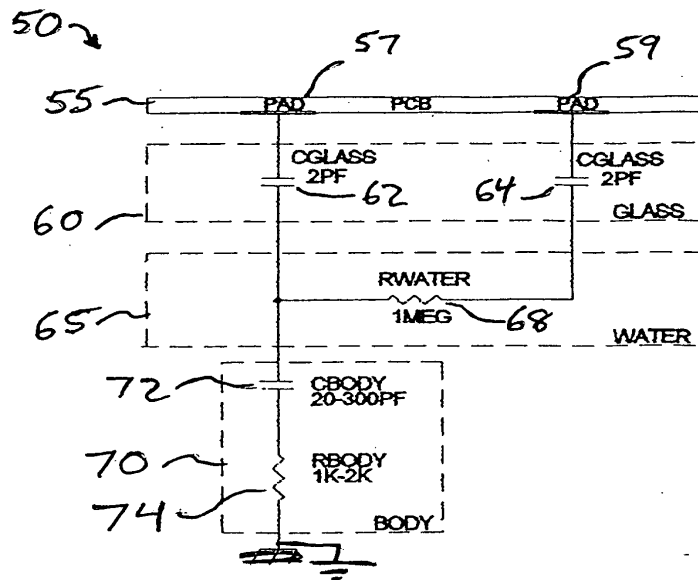

FIG. 3

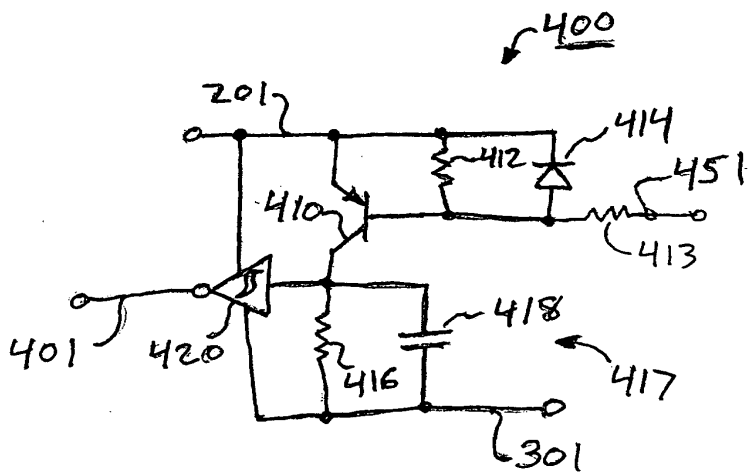

FIG. 8

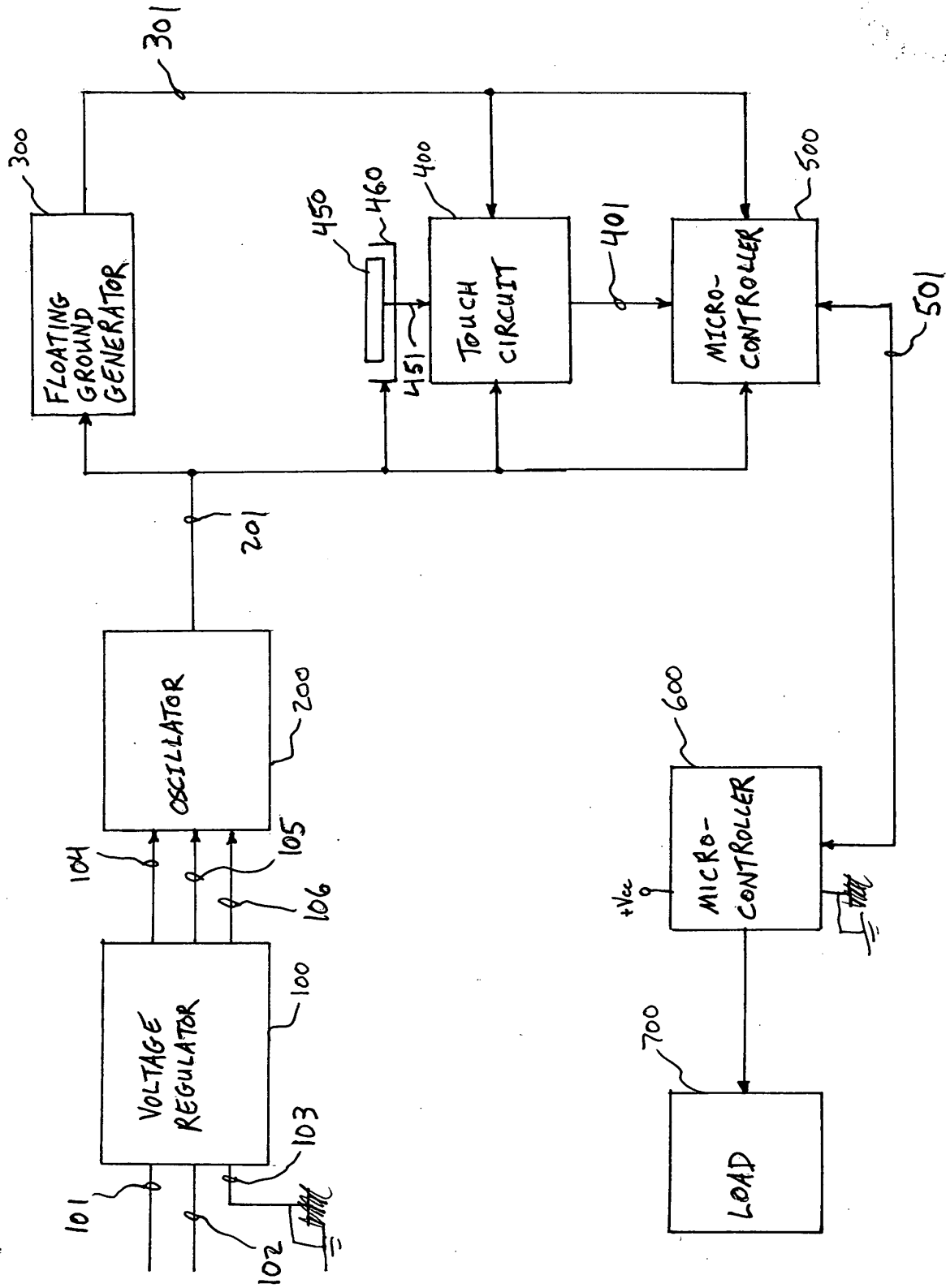

FIG. 4

FIG. 5

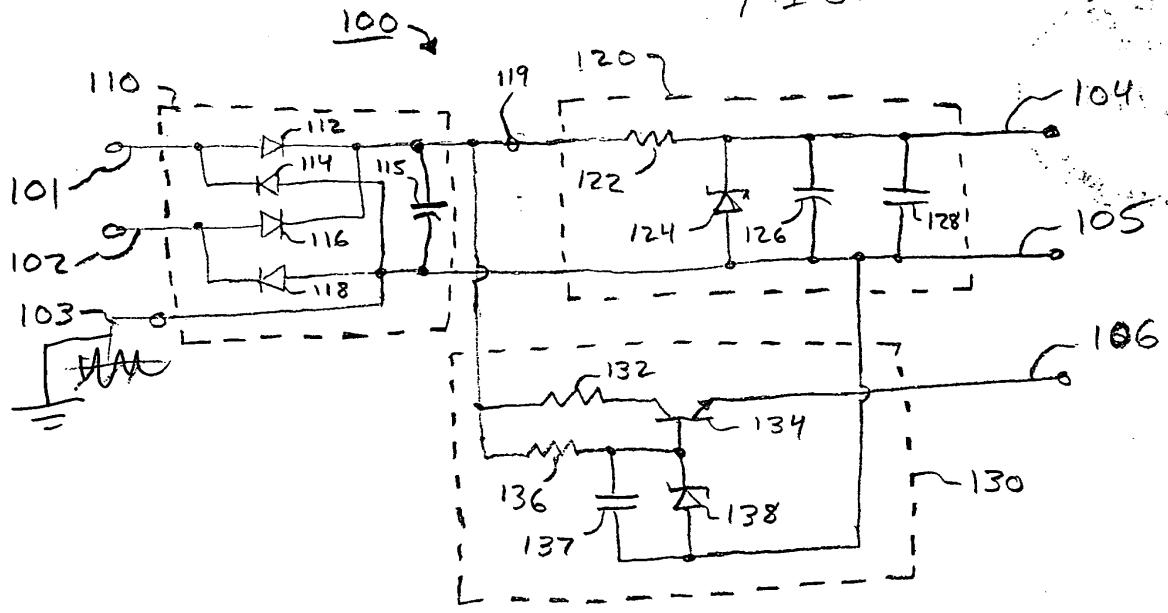

FIG. 6

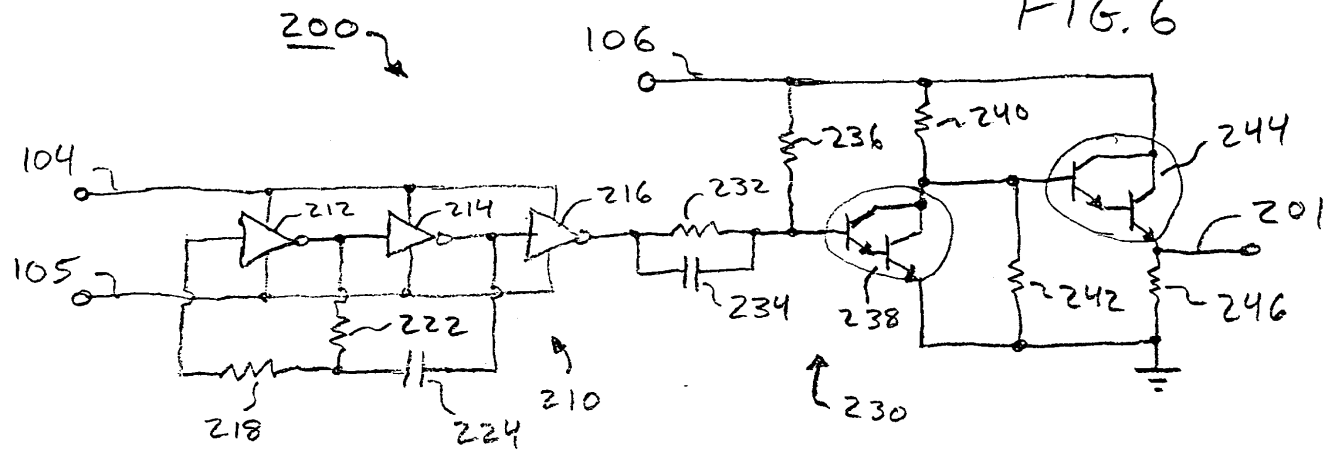
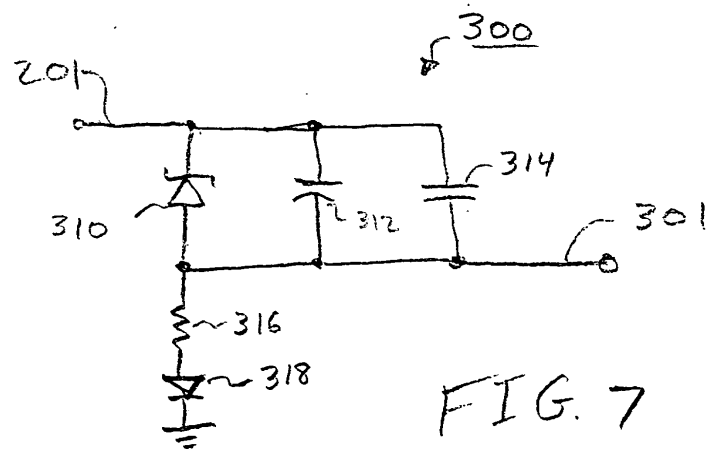

FIG. 7



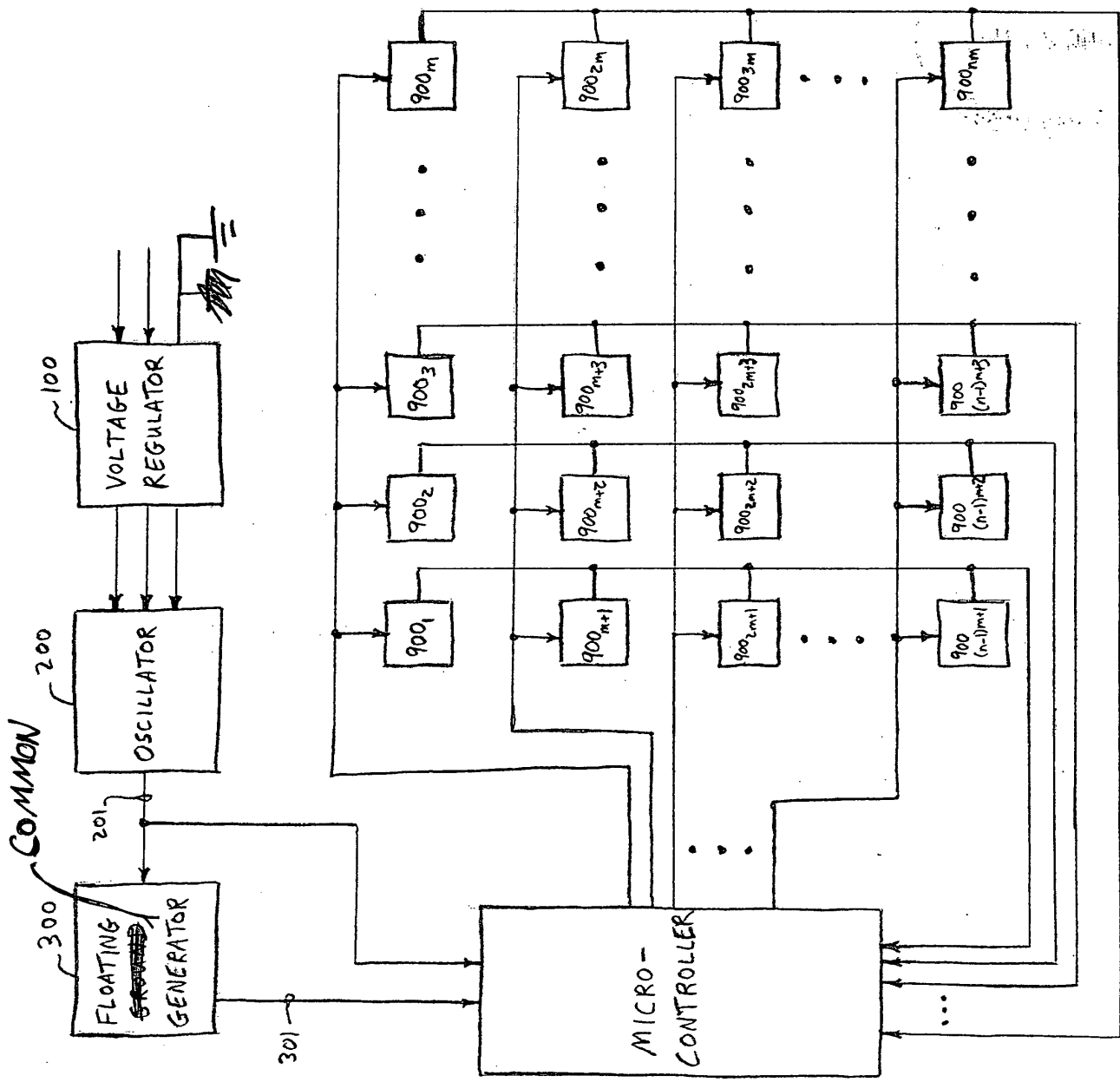

FIG. 11

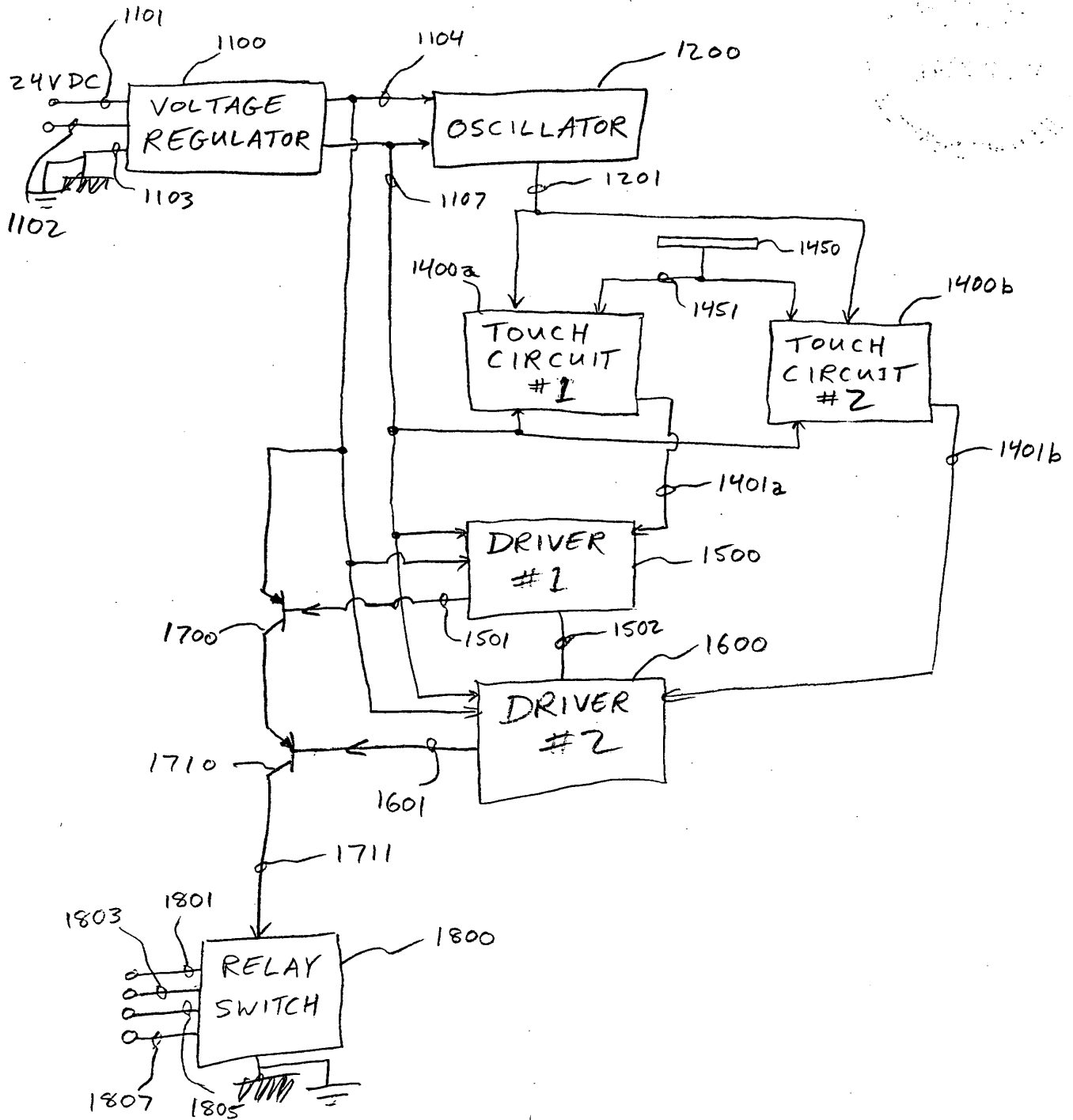

FIG. 12

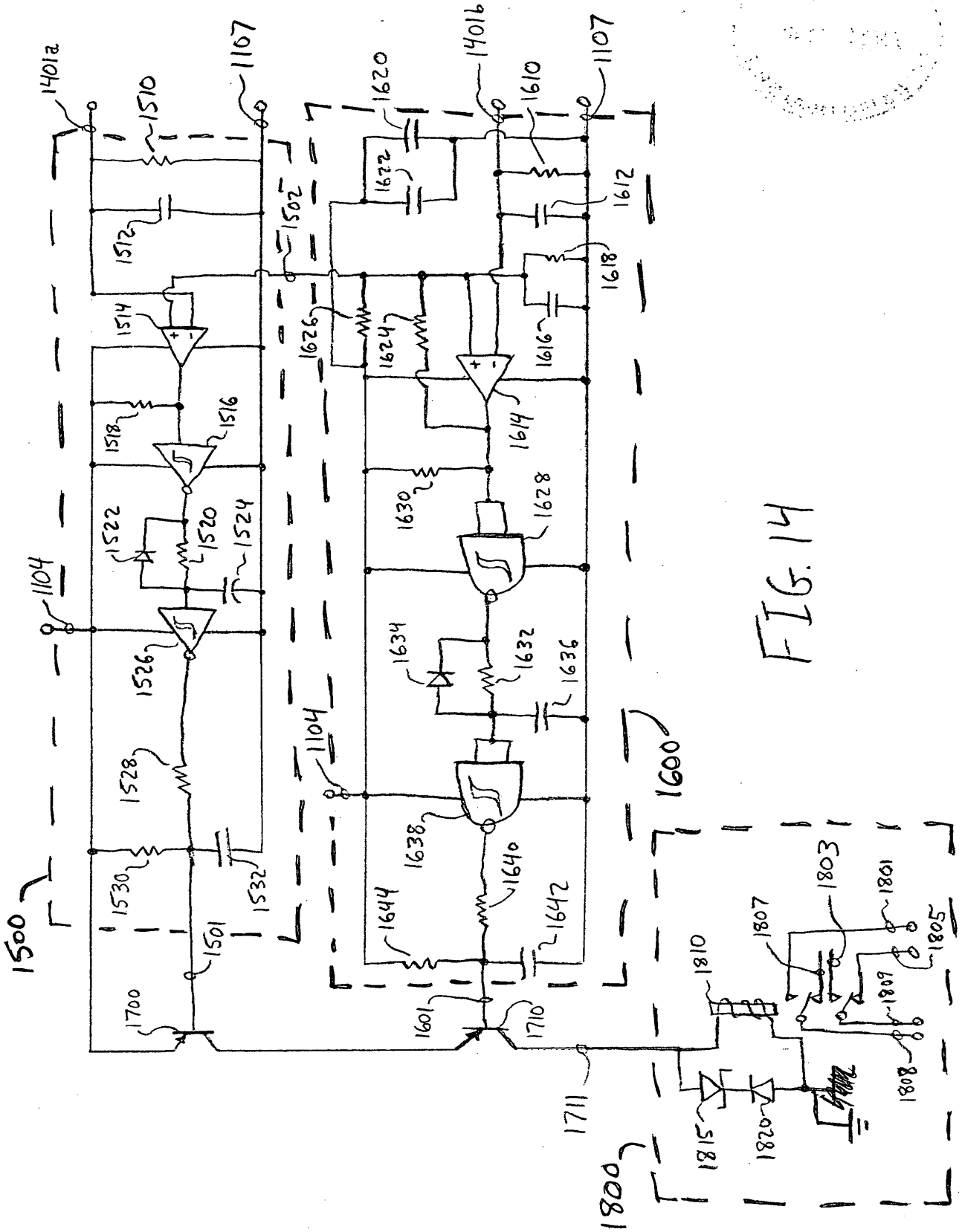

FIG. 14

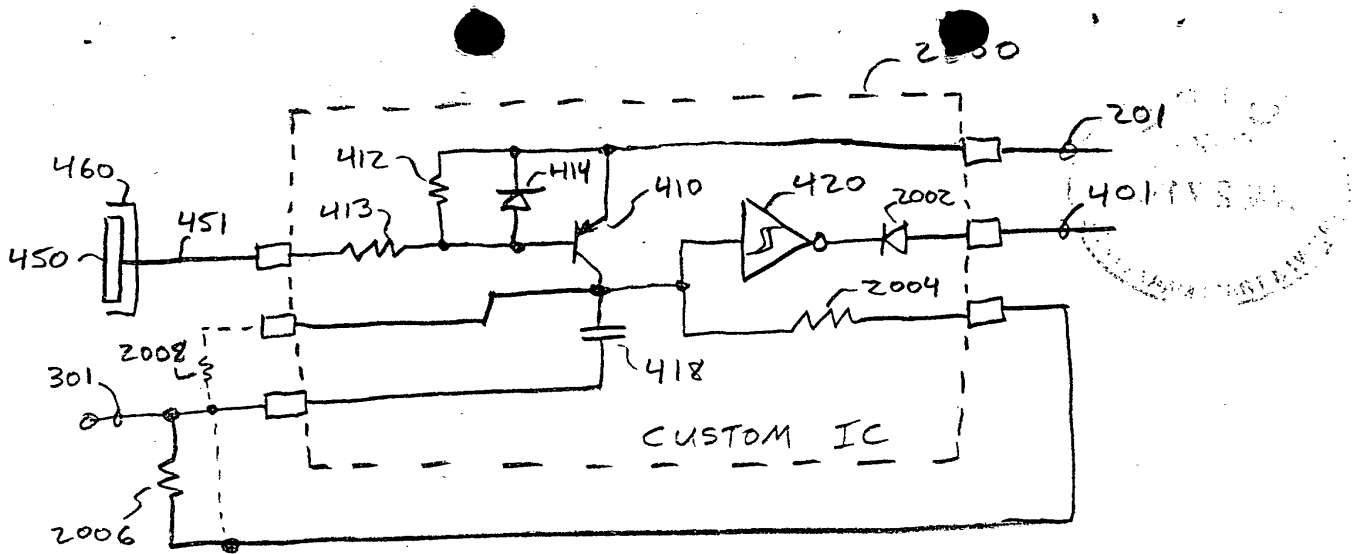

FIG. 17

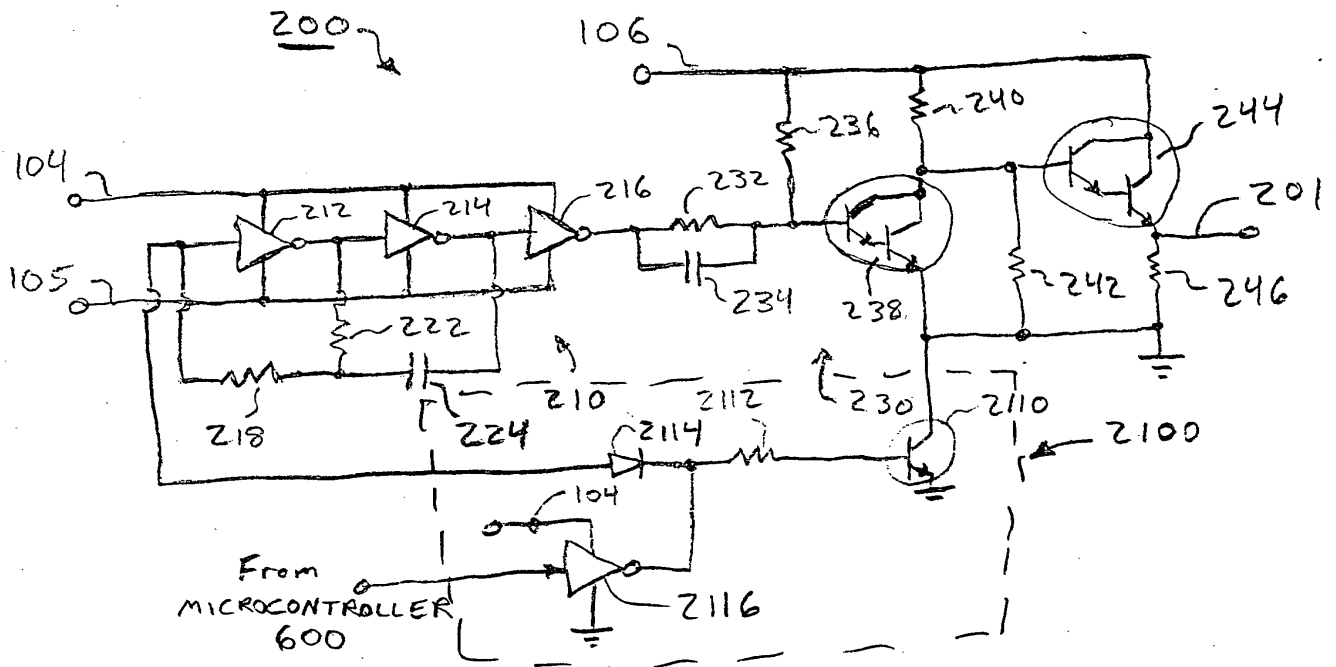

FIG. 18

GP 2107/A



Atty. Docket No. NAR01 P-310

CERTIFICATE OF MAILING

I hereby certify that this paper, together with all enclosures identified herein, are being deposited with the United States Postal Service as first class mail, addressed to the Assistant Commissioner for Patents, Washington D.C. 20231, on the date indicated below.

Date 8/22/97

Rebecca A. Schwartz
Rebecca A. Schwartz

IN THE UNITED STATES PATENT AND TRADEMARK OFFICE

RECEIVED

SEP 22 1997

GROUP 2100

10/A
w/ drug
case
Shuman
9-23-97
Shuman

Art Unit : 2107
Examiner : J. Kaplan
Appln. No. : 08/601,268
Filing Date : January 31, 1996
Applicant : Byron Hourmand
For : CAPACITIVE RESPONSIVE ELECTRONIC SWITCHING CIRCUIT

Assistant Commissioner for Patents
Washington, D.C. 20231

Dear Sir:

Enclosed is a response to the Office Action dated April 22, 1997. Also enclosed are nine sheets of corrected drawings. The items checked below are appropriate:

Applicants hereby petition for a one-month extension of time to respond to the above Office Action. The fee of \$55.00 for the Extension is enclosed.

Any fee for additional claims has been calculated as shown below:

CLAIMS AS AMENDED

	Col. 1		Col. 2		Col. 3		Small Entity		Other Than A Small Entity	
	Claims Remaining After Amendment		Highest No. Previously Paid For	Present Extra	Rate	Add'l Fee	Rate	Add'l Fee		
Total Claims	*32 160.00 OP 132.00 OP 55.00 OP	Minus	**20	=12	x \$11	\$132	x \$ 22	\$00		
Independent Claims	*08	Minus	***04	=04	x \$40	\$160	x \$ 80	\$00		
First Presentation of Multiple Dependent Claims						\$130	\$00	x \$260	\$00	
TOTAL ADDITIONAL FEE FOR THIS AMENDMENT							\$292		\$00	

09/16/1997 SEARCHED 00000062 06601263
01 FC:202
02 FC:203
03 FC:215

A

Applicant : Byron Hourmand
Appln. No. : 08/601,268
Page : 2

- * If the entry in Col. 1 is less than the entry in Col. 2, write "0" in Col. 3
- ** If the "Highest No. Previously Paid For" IN THIS SPACE is less than 20, write "20" in this space.
- *** If the "Highest No. Previously Paid For" IN THIS SPACE is less than 3, write "3" in this space.
The "Highest No. Previously Paid For" (Total or Independent) is the highest number found from the equivalent box in Col. 1 of a prior amendment or the number of claims originally filed.

Small entity status of this application under 37 C.F.R. §§ 1.9 and 1.27 has been established by a verified statement previously submitted.

No additional fee is required.

A fee of \$292.00 to cover the cost of the additional claims added by this response is enclosed.

Please charge any additional fees or credit overpayment to Deposit Account 16 2463. A duplicate copy of this sheet is attached.

PRICE, HENEVELD, COOPER,
DEWITT & LITTON

8-22-97

Date

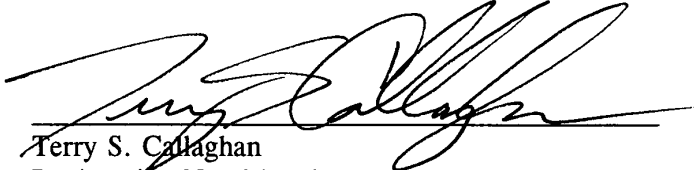
Terry S. Callaghan
Registration No. 34 559
695 Kenmoor, S.E.
Post Office Box 2567
Grand Rapids, Michigan 49501
(616) 949-9610

TSC/ras

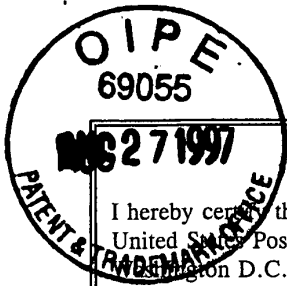

Atty. Docket No. NAR01 P-310

CERTIFICATE OF MAILING

I hereby certify that this paper, together with all enclosures identified herein, are being deposited with the United States Postal Service as first class mail, addressed to the Assistant Commissioner for Patents, Washington D.C. 20231, on the date indicated below.

8/22/97
Date

Rebecca A. Schwartz
Rebecca A. Schwartz

IN THE UNITED STATES PATENT AND TRADEMARK OFFICE

RECEIVED

SEP 22 1997

GROUP 2100

Art Unit : 2107
 Examiner : J. Kaplan
 Appln. No. : 08/601,268
 Filing Date : January 31, 1996
 Applicant : Byron Hourmand
 For : CAPACITIVE RESPONSIVE ELECTRONIC SWITCHING CIRCUIT

Assistant Commissioner for Patents
 Washington, D.C. 20231

Dear Sir:

Enclosed is a response to the Office Action dated April 22, 1997. Also enclosed are nine sheets of corrected drawings. The items checked below are appropriate:

Applicants hereby petition for a one-month extension of time to respond to the above Office Action. The fee of \$55.00 for the Extension is enclosed.

Any fee for additional claims has been calculated as shown below:

CLAIMS AS AMENDED

	Col. 1		Col. 2	Col. 3	Small Entity		Other Than A Small Entity	
	Claims Remaining After Amendment		Highest No. Previously Paid For	Present Extra	Rate	Add'l Fee	Rate	Add'l Fee
Total Claims	*32	Minus	**20	=12	x \$11	\$132	x \$ 22	\$00
Independent Claims	*08	Minus	***04	=04	x \$40	\$160	x \$ 80	\$00
First Presentation of Multiple Dependent Claims \$130						\$00	x \$260	\$00
TOTAL ADDITIONAL FEE FOR THIS AMENDMENT						\$292		\$00

Applicant : Byron Hourmand
Appln. No. : 08/601,268
Page : 2

- * If the entry in Col. 1 is less than the entry in Col. 2, write "0" in Col. 3
** If the "Highest No. Previously Paid For" IN THIS SPACE is less than 20, write "20" in this space.
*** If the "Highest No. Previously Paid For" IN THIS SPACE is less than 3, write "3" in this space.
The "Highest No. Previously Paid For" (Total or Independent) is the highest number found from the equivalent box in Col. 1 of a prior amendment or the number of claims originally filed.

- Small entity status of this application under 37 C.F.R. §§ 1.9 and 1.27 has been established by a verified statement previously submitted.
- No additional fee is required.
- A fee of \$292.00 to cover the cost of the additional claims added by this response is enclosed.
- Please charge any additional fees or credit overpayment to Deposit Account 16 2463. A duplicate copy of this sheet is attached.

PRICE, HENEVELD, COOPER,
DEWITT & LITTON

8-22-97
Date

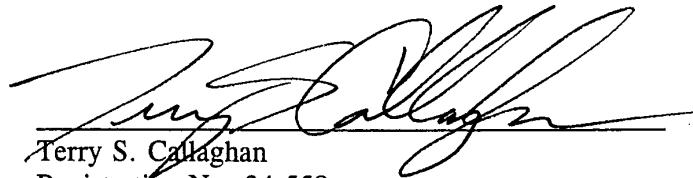
Terry S. Callaghan
Registration No. 34 559
695 Kenmoor, S.E.
Post Office Box 2567
Grand Rapids, Michigan 49501
(616) 949-9610

TSC/ras

65373 U.S. PTO
07/31/97

Atty. Docket No. NAR01 P-310 #9

CERTIFICATE OF MAILING

I hereby certify that this paper, together with all enclosures identified herein, are being deposited with the United States Postal Service as first class mail, addressed to the Assistant Commissioner for Patents, Washington D.C. 20231, on the date indicated below.

7/28/97
Date

Rebecca A. Schwartz
Rebecca A. Schwartz

IN THE UNITED STATES PATENT AND TRADEMARK OFFICE

RECEIVED

AUG 20 1997

GROUP 2100

Examiner : Jonathan S. Kaplan
 Art Unit : 2107
 Applicant : Byron Hourmand
 Appln. No. : 08/601,268
 Filed : January 31, 1996
 For : CAPACITIVE RESPONSIVE ELECTRONIC SWITCHING DEVICE

Assistant Commissioner for Patents
Washington, D.C. 20231

Dear Sir:

INFORMATION DISCLOSURE STATEMENT
UNDER 37 C.F.R. §1.97(c)

Pursuant to 37 C.F.R. §§1.56 and 1.97(c), Applicant brings to the attention of the Examiner the document listed on the attached Form PTO-1449. This Information Disclosure Statement is being filed after the events recited in §1.97(b) but, to the undersigned's knowledge, before the mailing date of either a Final Action or a Notice of Allowance. Under the provisions of 37 C.F.R. §1.97(c), this Information Disclosure Statement is accompanied by a certification as specified by §1.97(e).

Based on reasonable inquiry, no document listed in this Information Disclosure Statement was known to any individual designated in 37 C.F.R. §1.56(c) more than three months prior to the filing date of this Information Disclosure Statement.

A copy of the listed document is attached.

This submission does not represent that a search has been made or that no better art exists and does not constitute an admission that the listed document is material or constitutes "prior art." If it should be determined that the listed document does not constitute "prior art"

Applicant : Byron Hourmand
Appln. No. : 08/601,268
Page : 2

under United States law, Applicants reserve the right to present to the Office the relevant facts and law regarding the appropriate status of such document.

Applicant further reserves the right to take appropriate action to establish the patentability of the disclosed invention over the listed document, should the document be applied against the claims of the present application.

If there is any fee due in connection with the filing of this Statement, please charge the fee to our Deposit Account No. 16-2463.

Respectfully submitted,
BYRON HOURMAND

By: Price, Heneveld, Cooper,
DeWitt & Litton

7-28-97

Date

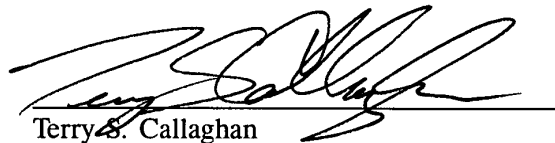

Terry S. Callaghan
Registration No. 34 559
695 Kenmoor, S.E.
Post Office Box 2567
Grand Rapids, MI 49501
(616) 949-9610

TSC/ras



**UNITED STATES DEPARTMENT OF COMMERCE
Patent and Trademark Office**

Address: COMMISSIONER OF PATENTS AND TRADEMARKS
Washington, D.C. 20231

APPLICATION NO.	FILING DATE	FIRST NAMED INVENTOR	ATTORNEY DOCKET NO.
08/601,268	01/31/96	HOURMAND	B NAR01-P-310

PRICE HENEVELD COOPER
DEWITT & LITTON
695 KENMOOR DRIVE SE
P O BOX 2567
GRAND RAPIDS MI 49501

21M1/0422

EXAMINER

KAPLAN, J

ART UNIT PAPER NUMBER

2107

8

DATE MAILED: 04/22/97

Please find below and/or attached an Office communication concerning this application or proceeding.

Commissioner of Patents and Trademarks

Office Action Summary

Application No. 08/601,268	Applicant(s) Hourmand
Examiner Jonathan S. Kaplan	Group Art Unit 2107



- Responsive to communication(s) filed on _____
- This action is **FINAL**.
- Since this application is in condition for allowance except for formal matters, **prosecution as to the merits is closed** in accordance with the practice under *Ex parte Quayle*, 1935 C.D. 11; 453 O.G. 213.

A shortened statutory period for response to this action is set to expire three month(s), or thirty days, whichever is longer, from the mailing date of this communication. Failure to respond within the period for response will cause the application to become abandoned. (35 U.S.C. § 133). Extensions of time may be obtained under the provisions of 37 CFR 1.136(a).

Disposition of Claims

- Claim(s) 1-20 is/are pending in the application.
Of the above, claim(s) _____ is/are withdrawn from consideration.
- Claim(s) _____ is/are allowed.
- Claim(s) 1-4, 6-14, and 16-20 is/are rejected.
- Claim(s) 5 and 15 is/are objected to.
- Claims _____ are subject to restriction or election requirement.

Application Papers

- See the attached Notice of Draftsperson's Patent Drawing Review, PTO-948.
- The drawing(s) filed on _____ is/are objected to by the Examiner.
- The proposed drawing correction, filed on _____ is approved disapproved.
- The specification is objected to by the Examiner.
- The oath or declaration is objected to by the Examiner.

Priority under 35 U.S.C. § 119

- Acknowledgement is made of a claim for foreign priority under 35 U.S.C. § 119(a)-(d).
 - All Some* None of the CERTIFIED copies of the priority documents have been
 - received.
 - received in Application No. (Series Code/Serial Number) _____
 - received in this national stage application from the International Bureau (PCT Rule 17.2(a)).
- *Certified copies not received: _____
- Acknowledgement is made of a claim for domestic priority under 35 U.S.C. § 119(e).

Attachment(s)

- Notice of References Cited, PTO-892
- Information Disclosure Statement(s), PTO-1449, Paper No(s). 5 and 6
- Interview Summary, PTO-413
- Notice of Draftsperson's Patent Drawing Review, PTO-948
- Notice of Informal Patent Application, PTO-152

--- SEE OFFICE ACTION ON THE FOLLOWING PAGES ---

Art Unit: 2107

DETAILED ACTION

Claim Rejections - 35 USC § 112

1. Claims 6, 7, and 16 are rejected under 35 U.S.C. 112, second paragraph, as being indefinite for failing to particularly point out and distinctly claim the subject matter which applicant regards as the invention.

Claims 6 and 16 are vague and indefinite because it is unclear what is meant by “to increase the sensitivity of said charge pump circuit to touching of said touch terminal by an operator’s body.”

Claim Rejections - 35 USC § 102

2. The following is a quotation of the appropriate paragraphs of 35 U.S.C. 102 that form the basis for the rejections under this section made in this Office action:

A person shall be entitled to a patent unless --

(b) the invention was patented or described in a printed publication in this or a foreign country or in public use or on sale in this country, more than one year prior to the date of application for patent in the United States.

3. Claims 1-4 and 12-14 are rejected under 35 U.S.C. 102(b) as being anticipated by Kent. (4,352,141)

Kent discloses a capacitive responsive switching comprising: an oscillator (N5, N6, R1, C1) having a frequency of 1 MHZ, an input touch terminal (3), a detector circuit (E) coupled to said oscillator and said touch input terminal, DC power supply (1), wherein said periodic input signal provided by said oscillator is a square wave see column 2, lines 9-12, and a plurality of

Art Unit: 2107

active elements coupled to an output of said oscillator to buffer and improve the shape of the square wave output therefrom (C3, C4, R2), and a charge pump (D1, N1, R4, and C6).

Claim Rejections - 35 USC § 103

4. The following is a quotation of 35 U.S.C. 103(a) which forms the basis for all obviousness rejections set forth in this Office action:

(a) A patent may not be obtained though the invention is not identically disclosed or described as set forth in section 102 of this title, if the differences between the subject matter sought to be patented and the prior art are such that the subject matter as a whole would have been obvious at the time the invention was made to a person having ordinary skill in the art to which said subject matter pertains. Patentability shall not be negated by the manner in which the invention was made.

5. Claims 8-11, 18, and 19 are rejected under 35 U.S.C. 103(a) as being unpatentable over Kent in view of Ingraham (5,087,825).

Claims 8 and 9 add the limitations of a microcontroller. Kent does not disclose the detector circuit including a microcontroller. However, Ingraham discloses a detector circuit including a microcontroller. (80) It would have been obvious to one of ordinary skill in the art to replace the detector circuit of Kent with the detector circuit of Ingraham in order to provide a computerized control circuit that can control a plurality of different load requirements sent by a plurality of touch sensors.

Claims 10 and 11 add the limitations of a plurality of input touch terminals and a plurality of touch circuits. Kent only teaches one touch input terminal and one touch circuitry. However, Ingraham discloses a plurality of input touch terminals (18) with corresponding touch circuits. It would have been obvious to one of ordinary skill in the art at the time the invention was made to

Art Unit: 2107

utilize the teachings of Ingraham into Kent's device for the purpose of providing a plurality of ways in which the load may be controlled see column 2, lines 36-40.

As to claims 18 and 19, Kent discloses a capacitive responsive switching comprising: an oscillator (N5, N6, R1, C1) having a frequency of 1 MHZ, an input touch terminal (3), and a detector circuit (E) coupled to said oscillator and said touch input terminal. Kent only teaches one touch input terminal and one touch circuitry. However, Ingraham discloses a plurality of input touch terminals (18) with corresponding touch circuits. It would have been obvious to one of ordinary skill in the art at the time the invention was made to utilize the teachings of Ingraham into Kent's device for the purpose of providing a plurality of ways in which the load may be controlled see column 2, lines 36-40. Kent also does not disclose the details of the touch input comprising a dielectric substrate. However, Ingraham does disclose a touch sensor comprising a dielectric layer substrate (26). It would have been obvious to one of ordinary skill in the art at the time the invention was made to utilize the teachings of Ingraham into Kent's device as this is a well known way to activate a capacitor switch input.

6. Claims 8-11, 18, and 19 are rejected under 35 U.S.C. 103(a) as being unpatentable over Kent in view of Kirton (5,235,217).

Kent discloses a capacitive responsive switching comprising: an oscillator (N5, N6, R1, C1) having a frequency of 1 MHZ, an input touch terminal (3), and a detector circuit (E) coupled to said oscillator and said touch input terminal.

Art Unit: 2107

Kent does not disclose the shape of the touch terminal. However, Kirton discloses a touch terminal (14) which is domed shaped. It would have been obvious to one of ordinary skill in the art at the time the invention was made to utilize the teachings of Kirton into Kent's device for the purpose of providing a touch sensor which is easy to operate.

7. Claims 5 and 15 are objected to as being dependent upon a rejected base claim, but would be allowable if rewritten in independent form including all of the limitations of the base claim and any intervening claims.

8. Claims 6, 7, and 16 would be allowable if rewritten to overcome the rejection(s) under 35 U.S.C. 112 set forth in this Office action and to include all of the limitations of the base claim and any intervening claims.

Any inquiry concerning this communication or earlier communications from the examiner should be directed to Jonathan S. Kaplan whose telephone number is (703) 308-1216.

Any inquiry of a general nature or relating to the status of this application should be directed to the Group receptionist whose telephone number is (703) 308-1782.

JSK
April 11, 1997

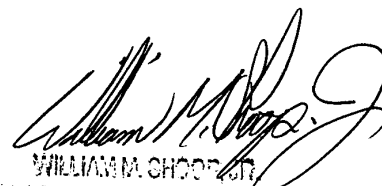
WILLIAM M. CHOOP, JR.
SUPERVISORY PATENT EXAMINER
ART UNIT 217

Notice of References Cited

Application No. 08/601,268	Applicant(s) Hourmand
Examiner Jonathan S. Kaplan	Group Art Unit 2107
Page 1 of 1	

U.S. PATENT DOCUMENTS

	DOCUMENT NO.	DATE	NAME	CLASS	SUBCLASS
A	599,523 4,352,141	8/1993	Kirton	307	326
B	4,352,141	9/1982	Kent	363	181
C					
D					
E					
F					
G					
H					
I					
J					
K					
L					
M					

FOREIGN PATENT DOCUMENTS

	DOCUMENT NO.	DATE	COUNTRY	NAME	CLASS	SUBCLASS
N						
O						
P						
Q						
R						
S						
T						

NON-PATENT DOCUMENTS

	DOCUMENT (Including Author, Title, Source, and Pertinent Pages)	DATE
U		
V		
W		
X		

NOTICE OF DRAFTSPERSON'S PATENT DRAWING REVIEW

PTO Draftpersons review all originally filed drawings regardless of whether they are designated as formal or informal. Additionally, patent Examiners will review the drawings for compliance with the regulations. Direct telephone inquiries concerning this review to the Drawing Review Branch, 703-305-8404.

The drawings filed (insert date) 1/31/96 are

A. not objected to by the Draftsperson under 37 CFR 1.84 or 1.152.

B. objected to by the Draftsperson under 37 CFR 1.84 or 1.152 as indicated below. The Examiner will require submission of new, corrected drawings when necessary. Corrected drawings must be submitted according to the instructions on the back of this Notice.

- DRAWINGS.** 37 CFR 1.84(a): Acceptable categories of drawings:
 - Black ink. Color.
 - Not black solid lines. Fig(s) _____
 - Color drawings are not acceptable until petition is granted. Fig(s) _____
- PHOTOGRAPHS.** 37 CFR 1.84(b)
 - Photographs are not acceptable until petition is granted. Fig(s) _____
 - Photographs not properly mounted (must use brylston board or photographic double-weight paper). Fig(s) _____
 - Poor quality (half-tone). Fig(s) _____
- GRAPHIC FORMS.** 37 CFR 1.84 (d)
 - Chemical or mathematical formula not labeled as separate figure. Fig(s) _____
 - Group of waveforms not presented as a single figure, using common vertical axis with time extending along horizontal axis. Fig(s) _____
 - Individuals waveform not identified with a separate letter designation adjacent to the vertical axis. Fig(s) _____
- TYPE OF PAPER.** 37 CFR 1.84(c)
 - Paper not flexible, strong, white, smooth, nonshiny, and durable. Sheet(s) _____
 - Creasures, alterations, overwritings, interlineations, cracks, creases, and folds copy machine marks not accepted. Fig(s) 1-200
 - Mylar, velum paper is not acceptable (too thin). Fig(s) _____
- SIZE OF PAPER.** 37 CFR 1.84(f): Acceptable sizes:
 - 21.6 cm. by 35.6 cm. (8 1/2 by 14 inches)
 - 21.6 cm. by 33.1 cm. (8 1/2 by 13 inches)
 - 21.6 cm. by 27.9 cm. (8 1/2 by 11 inches)
 - 21.0 cm. by 29.7 cm. (DIN size A4)
 - All drawing sheets not the same size. Sheet(s) _____
 - Drawing sheet not an acceptable size. Sheet(s) _____
- MARGINS.** 37 CFR 1.84(g): Acceptable margins:

Paper size			
21.6 cm. X 35.6 cm. (8 1/2 X 14 inches)	21.6 cm. X 33.1 cm. (8 1/2 X 13 inches)	21.6 cm. X 27.9 cm. (8 1/2 X 11 inches)	21.0 cm. X 29.7 cm. (DIN Size A4)
T 5.1 cm. (2")	2.5 cm. (1")	2.5 cm. (1")	2.5 cm.
L .64 cm. (1/4")	.64 cm. (1/4")	.64 cm. (1/4")	2.5 cm.
R .64 cm. (1/4")	.64 cm. (1/4")	.64 cm. (1/4")	1.5 cm.
B .64 cm. (1/4")	.64 cm. (1/4")	.64 cm. (1/4")	1.0 cm.

 - Margins do not conform to those above. Sheet(s) 5, 12, 13, 15A, 17
 - Top (T) _____ Left (L) _____ Right (R) _____ Bottom (B) _____
- VIEWS.** 37 CFR 1.84(h)
 - REMINDER: Specification may require revision to correspond to drawing changes.
 - All views not grouped together. Fig(s) _____
 - Views connected by projection lines or lead lines. Fig(s) _____
 - Partial views. 37 CFR 1.84(h) 2
- View and enlarged view not labeled separately or properly. Fig(s) _____
- Sectional views. 37 CFR 1.84 (h) 3
- Hatching not indicated for sectional portions of an object. Fig(s) _____
- Cross section not drawn same as view with parts in cross section with regularly spaced parallel oblique strokes. Fig(s) _____
- ARRANGEMENT OF VIEWS.** 37 CFR 1.84(i)
 - Words do not appear on a horizontal, left-to-right fashion when page is either upright or turned so that the top becomes the right side, except for graphs. Fig(s) _____
- SCALE.** 37 CFR 1.84(k)
 - Scale not large enough to show mechanism with crowding when drawing is reduced in size to two-thirds in reproduction. Fig(s) _____
 - Indication such as "actual size" or scale 1/2" not permitted. Fig(s) _____
- CHARACTER OF LINES, NUMBERS, & LETTERS.** 37 CFR 1.84(l)
 - Lines, numbers & letters not uniformly thick and well defined, clean, durable, and black (except for color drawings). Fig(s) 1-200
- SHADING.** 37 CFR 1.84(m)
 - Solid black shading areas not permitted. Fig(s) _____
 - Shade lines, pale, rough and blurred. Fig(s) _____
- NUMBERS, LETTERS, & REFERENCE CHARACTERS.** 37 CFR 1.84(p)
 - Numbers and reference characters not plain and legible. 37 CFR 1.84(p)(l) Fig(s) 1-200
 - Numbers and reference characters not oriented in same direction as the view. 37 CFR 1.84(p)(l) Fig(s) _____
 - English alphabet not used. 37 CFR 1.84(p)(2) Fig(s) _____
 - Numbers, letters, and reference characters do not measure at least .32 cm. (1/8 inch) in height. 37 CFR(p)(3) Fig(s) 3A
- LEAD LINES.** 37 CFR 1.84(q)
 - Lead lines cross each other. Fig(s) _____
 - Lead lines missing. Fig(s) _____
- NUMBERING OF SHEETS OF DRAWINGS.** 37 CFR 1.84(i)
 - Sheets not numbered consecutively, and in Arabic numerals, beginning with number 1. Sheet(s) _____
- NUMBER OF VIEWS.** 37 CFR 1.84(u)
 - Views not numbered consecutively, and in Arabic numerals, beginning with number 1. Fig(s) _____
 - View numbers not preceded by the abbreviation Fig. Fig(s) _____
- CORRECTIONS.** 37 CFR 1.84(w)
 - Corrections not made from prior PTO-948. Fig(s) _____
- DESIGN DRAWING.** 37 CFR 1.152
 - Surface shading shown not appropriate. Fig(s) _____
 - Solid black shading not used for color contrast. Fig(s) _____

COMMENTS:



Form PTO-1449

U.S. DEPARTMENT OF COMMERCE
PATENT AND TRADEMARK OFFICE

ATTY. DOCKET NO.

NAR01 P-310

SERIAL NO.

05/601,268

INFORMATION DISCLOSURE STATEMENT
BY APPLICANT

APPLICANTS

Byron Hourmand

FILING DATE

GROUP

U.S. PATENT DOCUMENTS

EXAMINER INITIAL	PATENT NUMBER								ISSUE DATE	NAME	CLASS	SUBCLASS	FILING DATE IF APPROPRIATE
OK	5	4	5	3	6	4	4	09/26/95	Yap et al.				
	5	3	8	6	2	1	9	01/31/95	Greanias et al.				
	5	2	3	5	2	1	7	08/10/93	Kirton				
	5	2	3	3	2	3	1	08/03/93	Wieth et al.				
	5	2	0	8	5	1	6	05/04/93	Saidian				
	5	0	8	7	8	2	5	02/11/92	Ingraham				
	5	0	6	6	8	9	8	11/19/91	Miller et al.				
	5	0	1	2	1	2	4	04/30/91	Hollaway				
	4	9	3	9	3	8	2	07/03/90	Gruodis				
	4	9	1	0	5	0	4	03/20/90	Eriksson				
	4	8	3	1	2	7	9	05/16/89	Ingraham				
	4	7	5	8	7	3	5	07/19/88	Ingraham				
	4	7	3	1	5	4	8	03/15/88	Ingraham				
	4	4	7	6	4	6	3	10/09/84	Ng et al.				
	4	3	7	4	3	8	1	02/15/83	Ng et al.				
	4	3	6	0	7	3	7	11/23/82	Leopold				
	4	3	2	3	8	2	9	04/06/82	Witney et al.				
	4	3	0	8	4	4	3	12/29/81	Tucker et al.				
4	2	8	9	9	8	0	09/15/81	McLaughlin					
4	2	8	9	9	7	2	09/15/81	Wern					
4	2	6	4	8	3	1	04/28/81	Wern					
4	2	5	7	1	1	7	03/17/81	Besson					

FOREIGN PATENT DOCUMENTS

DOCUMENT NUMBER	PUBLICATION DATE	COUNTRY	CLASS	SUBCLASS	TRANSLATION	
					YES	NO

OTHER DOCUMENTS (Including Author, Title, Date, Pertinent Pages, Etc.)

--	--

EXAMINER

Jonathan Kaplan

DATE CONSIDERED

4/11/97

EXAMINER: Initial if citation is considered, whether or not citation is in conformance with MPEP 609; Draw line through citation if not in conformance and not considered. Include copy of this form with next communication to applicant.



Form PTO-1449

U.S. DEPARTMENT OF COMMERCE
PATENT AND TRADEMARK OFFICE

ATTY. DOCKET NO.

NAR01 P-310

SERIAL NO.

08/601268

INFORMATION DISCLOSURE STATEMENT
BY APPLICANT

APPLICANTS

Byron Hourmand

FILING DATE

GROUP

U.S. PATENT DOCUMENTS

EXAMINER INITIAL	PATENT NUMBER								ISSUE DATE	NAME	CLASS	SUBCLASS	FILING DATE IF APPROPRIATE
	4	2	4	6	5	3	3						
OK	4	2	4	6	5	3	3	01/20/81	Chiang				
	4	2	3	7	4	2	1	12/02/80	Waldron				
	4	2	2	0	8	1	5	09/02/80	Gibson et al.				
	4	2	1	3	0	6	1	07/15/80	Conner				
	4	2	1	1	9	5	9	07/08/80	Deavenport et al.				
	4	2	1	0	8	2	2	07/01/80	Wern				
	4	1	5	9	4	7	3	06/26/79	Senk				
	4	1	5	2	6	2	9	05/01/79	Raupp				
	4	1	1	9	8	6	4	10/10/78	Petrizio				
	4	1	0	1	8	0	5	07/18/78	Stone				
	4	0	7	1	6	8	9	01/31/78	Talmage et al.				
	4	0	3	1	4	0	8	06/21/77	Holz				
	4	0	1	6	4	5	3	04/05/77	Moennig				
	3	9	8	4	7	5	7	10/05/76	Gott et al.				
	3	9	6	5	4	6	5	06/22/76	Alexander				
	3	9	1	9	5	9	6	11/11/75	Bellis				
	3	9	1	1	2	1	5	10/07/75	Hurst et al.				
	3	8	9	9	7	1	3	08/12/75	Barkan et al.				
	3	7	9	8	3	7	0	03/19/74	Hurst				
	3	6	6	6	9	8	8	05/30/72	Bellis				
3	6	5	1	3	9	1	03/21/72	Vogelsberg					
3	6	4	1	4	1	0	02/08/72	Vogelsberg					
3	5	4	9	9	0	9	08/25/69	Adelson et al.					

FOREIGN PATENT DOCUMENTS

DOCUMENT NUMBER	PUBLICATION DATE	COUNTRY	CLASS	SUBCLASS	TRANSLATION	
					YES	NO

OTHER DOCUMENTS (Including Author, Title, Date, Pertinent Pages, Etc.)

--

EXAMINER

Jonathan R. Kaplan

DATE CONSIDERED

4/11/97

EXAMINER: Initial if citation is considered, whether or not citation is in conformance with MPEP 609; Draw line through citation if not in conformance and not considered. Include copy of this form with next communication to applicant.

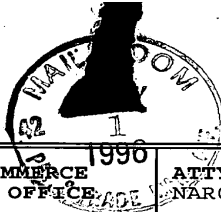

5/1/96

FORM PTO-1449 U.S. DEPARTMENT OF COMMERCE (Rev. 2-32) PATENT AND TRADEMARK OFFICE INFORMATION DISCLOSURE STATEMENT BY APPLICANT (Use several sheets if necessary)	ATTY. DOCKET NO. NAR01 P-310	SERIAL NO. 08/601,268 (unofficial)
	APPLICANT(S) Byron Hourmand	
	FILING DATE 01/31/96	GROUP

U.S. PATENT DOCUMENTS

EXAMINER INITIAL	DOCUMENT NUMBER								DATE	NAME	CLASS	SUB-CLASS	FILING DATE IF APPROPRIATE
[Handwritten initials]	3	8	7	9	6	1	8	04/22/75	Larson	367	116		
	4	5	0	3	2	9	4	03/05/85	Matsumaru	200	5A		
	4	9	4	2	6	3	1	07/24/90	Rosa	4	623		

FOREIGN PATENT DOCUMENTS

EXAMINER INITIAL	DOCUMENT NUMBER								DATE	COUNTRY	CLASS	SUB-CLASS	TRANSLATION	
													Y	N

OTHER DOCUMENTS (Including Author, Title, Date, Pertinent Pages, Etc.)

EXAMINER INITIAL	

EXAMINER <i>Jonathan Kaplan</i>	DATE CONSIDERED <i>4/11/97</i>
EXAMINER: Initial if citation considered, whether or not citation is in conformance with MPEP 609; Draw line through citation if not in conformance and not considered. Include copy of this form with next communication to applicant.	



UNITED STATES DEPARTMENT OF COMMERCE
 Patent and Trademark Office
 Address: COMMISSIONER OF PATENTS AND TRADEMARKS
 Washington, D.C. 20231

#3

APPLICATION NUMBER	FILING DATE	FIRST NAMED APPLICANT	ATTY. DOCKET NO./TITLE
--------------------	-------------	-----------------------	------------------------

08/601,268 01/31/96 HOURMAND B NAR01-P310

0232/0506

TERRY S CALLAGHAN
 PRICE HENEVELD COOPER
 DEWITT & BITTON
 695 KENMOOR SE P O BOX 2567
 GRAND RAPIDS MI 49501

DATE MAILED: 0000

NOTICE TO FILE MISSING PARTS OF APPLICATION 5/06/96
FILING DATE GRANTED

An Application Number and Filing Date have been assigned to this application. However, the items indicated below are missing. The required items and fees identified below must be timely submitted **ALONG WITH THE PAYMENT OF A SURCHARGE** for items 1 and 3-6 only of \$ 130 for large entities or \$ 65 for small entities who have filed a verified statement claiming such status. The surcharge is set forth in 37 CFR 1.16(e).

If all required items on this form are filed within the period set below, the total amount owed by applicant as a large entity, small entity (verified statement filed), is \$ 544.

Applicant is given **ONE MONTH FROM THE DATE OF THIS LETTER, OR TWO MONTHS FROM THE FILING DATE** of this application, **WHICHEVER IS LATER**, within which to file all required items and pay any fees required above to avoid abandonment. Extensions of time may be obtained by filing a petition accompanied by the extension fee under the provisions of 37 CFR 1.136(a).

1. The statutory basic filing fee is: missing insufficient. Applicant as a large entity small entity, must submit \$ 414 to complete the basic filing fee.
2. Additional claim fees of \$ _____ as a large entity, small entity, including any required multiple dependent claim fee, are required. Applicant must submit the additional claim fees or cancel the additional claims for which fees are due.
3. The oath or declaration:
 - is missing.
 - does not cover the newly submitted items.

An oath or declaration in compliance with 37 CFR 1.63, identifying the application by the above Application Number and Filing Date is required.
4. The oath or declaration does not identify the application to which it applies. An oath or declaration in compliance with 37 CFR 1.63, identifying the application by the above Application Number and Filing Date, is required.
5. The signature(s) to the oath or declaration is/are: missing; by a person other than the inventor or a person qualified under 37 CFR 1.42, 1.43, or 1.47. A properly signed oath or declaration in compliance with 37 CFR 1.63, identifying the application by the above Application Number and Filing Date, is required.
6. The signature of the following joint inventor(s) is missing from the oath or declaration:

_____ An oath or declaration listing the names of all inventors and signed by the omitted inventor(s), identifying this application by the above Application Number and Filing Date, is required.
7. The application was filed in a language other than English. Applicant must file a verified English translation of the application and a fee of \$ _____ under 37 CFR 1.17(k), unless this fee has already been paid.
8. A \$ _____ processing fee is required since your check was returned without payment. (37 CFR 1.21(m)).
9. Your filing receipt was mailed in error because your check was returned without payment.
10. The application does not comply with the Sequence Rules. See attached Notice to Comply with Sequence Rules 37 CFR 1.821-1.825.
11. Other.

Direct the response to Box Missing Part and refer any questions to the Customer Service Center at (703) 308-1202.

A copy of this notice *MUST* be returned with the response.

COPY TO BE RETURNED WITH RESPONSE

FORM PTO-1533 (REV. 11-94)

28-601268

Applicants or Patentees: Byron Hourmand

Serial or Patent No.: _____

Filed or Issued: _____

For: CAPACITIVE RESPONSIVE ELECTRONIC SWITCHING CIRCUIT



VERIFIED STATEMENT (DECLARATION) CLAIMING SMALL ENTITY STATUS (37 C.F.R. § 1.9(f) and 1.27(c)) - SMALL BUSINESS CONCERN

I hereby declare that I am

- () the owner of the small business concern identified below:
- an official of the small business concern empowered to act on behalf of the concern identified below.

NAME OF CONCERN Natron Corporation

ADDRESS OF CONCERN 5000 North U.S. 131

Reed City, Michigan 49677-0207

I hereby declare that the above identified small business concern qualifies as a small business concern as defined in 13 C.F.R. § 121.3-18, and reproduced in 37 C.F.R. § 1.9(d), for purposes of paying reduced fees under sections 41(a) and (b) of Title 35, United States Code, in that the number of employees of the concern, including those of its affiliates, does not exceed 500 persons. For purposes of this statement, (1) the number of employees of the business concern is the average over the previous fiscal year of the concern of the persons employed on a full-time, part-time or temporary basis during each of the pay periods of the fiscal year, and (2) concerns are affiliates of each other when either, directly or indirectly, one concern controls or has the power to control the other, or a third party or parties controls or has the power to control both.

I hereby declare that rights under contract or law have been conveyed to and remain with the small business concern identified above with regard to the invention, entitled CAPACITIVE RESPONSIVE ELECTRONIC SWITCHING CIRCUIT by inventor Byron Hourmand described in the specification filed herewith.

If the rights held by the above identified small business concern are not exclusive, each individual, concern or organization having rights to the invention is listed below* and no rights to the invention are held by any person, other than the inventor, who could not qualify as an independent inventor under 37 C.F.R. § 1.9(c) or by any concern which would not qualify as a small business concern under 37 C.F.R. § 1.9(d) or a nonprofit organization under 37 C.F.R. § 1.9(e). *NOTE: Separate verified statements are required from each named person, concern or organization having rights to the invention averring to their status as small entities (37 C.F.R. § 1.27).

NAME _____

ADDRESS _____

- INDIVIDUAL
- SMALL BUSINESS CONCERN
- NON-PROFIT ORGANIZATION

NAME _____

ADDRESS _____

- INDIVIDUAL
- SMALL BUSINESS CONCERN
- NON-PROFIT ORGANIZATION

I acknowledge the duty to file, in this application or patent, notification of any change in status resulting in loss of entitlement to small entity status prior to paying, or at the time of paying, the earliest of the issue fee or any maintenance fee due after the date on which status as a small entity is no longer appropriate. (37 C.F.R. § 1.28(b)).

I hereby declare that all statements made herein of my own knowledge are true and that all statements made on information and belief are believed to be true; and further that these statements were made with the knowledge that willful false statements and the like so made are punishable by fine or imprisonment, or both, under Section 1001 of Title 18 of the United States Code, and that such willful false statements may jeopardize the validity of the application, any patent issuing thereon, or any patent to which this verified statement is directed.

NAME OF PERSON SIGNING Dr. Terry Carrell

TITLE OF PERSON OTHER THAN OWNER President

ADDRESS OF PERSON SIGNING 5000 North U.S. 131, Reed City, Michigan 49677-0207

SIGNATURE [Signature]

DATE 31 JANUARY 1996

#3

DECLARATION AND POWER OF ATTORNEY

As a below named inventor, I hereby declare:

My residence, post office address and citizenship are as stated below next to my name.

I believe I am an original, first and sole inventor of the subject matter which is claimed and for which a patent is sought on the invention entitled **CAPACITIVE RESPONSIVE ELECTRONIC SWITCHING CIRCUIT**, the specification of which was filed on January 31, 1996, Application No. 08/601,268 (unofficial).

I have reviewed and understand the contents of the above-identified specification, including the claims, as amended by any amendment referred to above.

I acknowledge the duty to disclose to the United States Patent and Trademark Office (the Office), all information which is known by me to be material to patentability as defined in Title 37, Code of Federal Regulations (C.F.R.), Section 1.56.

POWER OF ATTORNEY

I hereby appoint the patent law firm of Price, Heneveld, Cooper, DeWitt and Litton, P.O. Box 2567, 695 Kenmoor Drive, S.E., Grand Rapids, Michigan 49501, telephone number 616-949-9610, facsimile number 616-957-8196, and the individual patent attorneys and patent agents at such patent law firm, namely, Lloyd A. Heneveld, Reg. No. 17 802; Richard C. Cooper, Reg. No. 19 164; William W. DeWitt, Reg. No. 22 300; Randall G. Litton, Reg. No. 24 013; James A. Mitchell, Reg. No. 25 120; Harold W. Reick, Reg. No. 25 438; Robert J. Carrier, Reg. No. 24 219; Carl S. Clark, Reg. No. 28 288; Daniel L. Girdwood, Reg. No. 34 827; Barry C. Kane, Reg. No. 32 036; Terry S. Callaghan, Reg. No. 34 559; Gunther J. Evanina, Reg. No. 35 502; and Steven C. Wichmann, Reg. No. 37 758, my attorney(s) or agent(s) with full power of substitution and revocation, to prosecute this application and to transact all business in and to receive all correspondence from the Patent and Trademark Office connected therewith.

13

All statements made herein of my own knowledge are true and all statements made on information and belief are believed to be true, and further, these statements are made with the knowledge that willful false statements and the like are punishable by fine or imprisonment, or both, under 18 U.S.C. § 1001, and that such willful false statements may jeopardize the validity of this application or any patent issued thereon.

Sole inventor:

100 B. Hourmand 5-14-96
B. Hourmand ~~5-14-96~~

Byron (NMI) Hourmand Date
Citizenship: United States of America
Residence: Hersey, Michigan MI
Post Office Address: 19009 23 Mile Rd.
Hersey, MI 49639



65-205

DBCO

PATENT
Atty. Docket No. NAR01 P-310

IN THE UNITED STATES PATENT AND TRADEMARK OFFICE

Applicant : B. Hourmand
Serial No. : 08/601,268
Filing Date : January 31, 1996
For : CAPACITIVE RESPONSIVE ELECTRONIC SWITCHING CIRCUIT

Hon. Commissioner of Patents and Trademarks
Box Missing Part
Washington, D.C. 20231

Dear Sir:

CERTIFICATE OF MAILING

I hereby certify that the attached Notice to File Missing Parts of Application Filing Date Granted, Declaration and Power of Attorney, Verified Statement Claiming Small Entity Status (Small Business Concern), Check in the amount of \$65 (surcharge fee), and Return Postcard are being deposited with the United States Postal Service as first class mail in an envelope addressed to:

Hon. Commissioner of Patents and Trademarks
Box Missing Part
Washington, D.C. 20231

on 5/16/96.

Rebecca A. Schwartz
Price, Heneveld, Cooper,
DeWitt & Litton
695 Kenmoor, S.E.
P.O. Box 2567
Grand Rapids, Michigan 49501
(616) 949-9610

310 80 05/23/96 08601266
1 505 65.00 CR



230-5-7-96 Receipts #7 928-961 J.W.H.

PATENT Atty. Docket No. NAR01 P-310

IN THE UNITED STATES PATENT AND TRADEMARK OFFICE

AUG 06 1996

Applicant : Byron Hourmand
Appln. No. : 08/601,268 (unofficial)
Filed : January 31, 1996 (unofficial)
For : CAPACITIVE RESPONSIVE ELECTRONIC SWITCHING CIRCUIT

GROUP 210

Hon. Commissioner of Patents and Trademarks
Washington, D.C. 20231

Dear Sir:

A check of our files indicates that the above-identified application has been filed more than three (3) months without a Filing Receipt being received by us. Therefore, would you please give us the status of the above application. This request is made to avoid any lack of diligence being attributed to the Applicant.

Respectfully submitted,

BYRON HOURMAND

By: Price, Heneveld, Cooper, DeWitt & Litton

[Handwritten signature of Terry S. Callaghan]

Terry S. Callaghan
Registration No. 34 559
695 Kenmoor S.E.
P.O. Box 2567
Grand Rapids, Michigan 49501
(616) 949-9610

5-9-96
Date

TSC/ras



PATENT
Atty. Docket No. NAR01 P-310

IN THE UNITED STATES PATENT AND TRADEMARK OFFICE

AUG 06 1996

Applicant : Byron Hourmand
Appl. No. : 08/601,268 (unofficial)
Filed : January 31, 1996 (unofficial)
For : CAPACITIVE RESPONSIVE ELECTRONIC SWITCHING CIRCUIT

GROUP 210

Hon. Commissioner of Patents and Trademarks
Washington, D.C. 20231

Dear Sir:

CERTIFICATE OF MAILING

I hereby certify that the attached Status Request Letter and Return Postcard are being deposited with the United States Postal Service as first class mail in an envelope addressed to:

Hon. Commissioner of Patents and Trademarks
Washington, D.C. 20231

on 5/9/96

Rebecca A. Schwartz
Price, Heneveld, Cooper,
DeWitt & Litton
695 Kenmoor, S.E.
P.O. Box 2567
Grand Rapids, Michigan 49501
(616) 949-9610



UNITED STATES DEPARTMENT OF COMMERCE
Patent and Trademark Office
 Address: COMMISSIONER OF PATENTS AND TRADEMARKS
 Washington, D.C. 20231

#12

ep

APPLICATION NUMBER	FILING DATE	FIRST NAMED APPLICANT	ATTY. DOCKET NO./TITLE
--------------------	-------------	-----------------------	------------------------

08/601,268 01/31/96 HOURMAND B NAR01-P310

0232/0506

TERRY S CALLAGHAN
 PRICE HENEVELD COOPER
 DEWITT & LITTON
 695 KENMOOR SE P O BOX 2567
 GRAND RAPIDS MI 49501

DATE MAILED: 05/06/96

NOTICE TO FILE MISSING PARTS OF APPLICATION
FILING DATE GRANTED

An Application Number and Filing Date have been assigned to this application. However, the items indicated below are missing. The required items and fees identified below must be timely submitted **ALONG WITH THE PAYMENT OF A SURCHARGE** for items 1 and 3-6 only of \$ 130 for large entities or \$ 45 for small entities who have filed a verified statement claiming such status. The surcharge is set forth in 37 CFR 1.16(e).

If all required items on this form are filed within the period set below, the total amount owed by applicant as a large entity, small entity (verified statement filed), is \$ 544.

Applicant is given **ONE MONTH FROM THE DATE OF THIS LETTER, OR TWO MONTHS FROM THE FILING DATE** of this application, **WHICHEVER IS LATER**, within which to file all required items and pay any fees required above to avoid abandonment. Extensions of time may be obtained by filing a petition accompanied by the extension fee under the provisions of 37 CFR 1.136(a).

1. The statutory basic filing fee is: missing insufficient. Applicant as a large entity small entity, must submit \$ 414 to complete the basic filing fee.
2. Additional claim fees of \$ _____ as a large entity, small entity, including any required multiple dependent claim fee, are required. Applicant must submit the additional claim fees or cancel the additional claims for which fees are due.
3. The oath or declaration:
 - is missing.
 - does not cover the newly submitted items.

An oath or declaration in compliance with 37 CFR 1.63, identifying the application by the above Application Number and Filing Date is required.
4. The oath or declaration does not identify the application to which it applies. An oath or declaration in compliance with 37 CFR 1.63, identifying the application by the above Application Number and Filing Date, is required.
5. The signature(s) to the oath or declaration is/are: missing; by a person other than the inventor or a person qualified under 37 CFR 1.42, 1.43, or 1.47. A properly signed oath or declaration in compliance with 37 CFR 1.63, identifying the application by the above Application Number and Filing Date, is required.
6. The signature of the following joint inventor(s) is missing from the oath or declaration: _____
 An oath or declaration listing the names of all inventors and signed by the omitted inventor(s), identifying this application by the above Application Number and Filing Date, is required.
7. The application was filed in a language other than English. Applicant must file a verified English translation of the application and a fee of \$ _____ under 37 CFR 1.17(k), unless this fee has already been paid.
8. A \$ _____ processing fee is required since your check was returned without payment. (37 CFR 1.21(m)).
9. Your filing receipt was mailed in error because your check was returned without payment.
10. The application does not comply with the Sequence Rules. See attached Notice to Comply with Sequence Rules 37 CFR 1.821-1.825.
11. Other.

Direct the response to Box Missing Part and refer any questions to the Customer Service Center at (703) 308-1202.

A copy of this notice MUST be returned with the response.

OFFICE COPY

5/1/96 #6
PATENT
NAR01 P-310

IN THE UNITED STATES PATENT AND TRADEMARK OFFICE

Applicant : Byron Hourmand
Serial No. : 08/601,268 (unofficial)
Filing Date : January 31, 1996 (unofficial)
For : CAPACITIVE RESPONSIVE ELECTRONIC SWITCHING CIRCUIT

Hon. Commissioner of Patents and Trademarks
Washington, D.C. 20231

Dear Sir:

INFORMATION DISCLOSURE STATEMENT UNDER 37 C.F.R. § 1.97(b)

Pursuant to 37 C.F.R. §§1.56 and 1.97(b), Applicant brings to the attention of the Examiner the documents listed on the attached Form PTO-1449. This Information Disclosure Statement is being filed within three months of the filing date of the above-referenced application.

Copies of the listed documents are submitted herewith along with Form PTO-1449. Applicant respectfully requests that the Examiner consider the listed documents and evidence that consideration of relevant portions thereof by making appropriate notations on the attached form.

This submission does not represent that a search has been made or that no better art exists and does not constitute an admission that each or all of the listed documents are material or constitute "prior art." If it should be determined that any of the listed documents do not constitute "prior art" under United States law, Applicant reserves the right to present to the Office the relevant facts and law regarding the appropriate status of such documents.

Applicant further reserves the right to take appropriate action to establish the patentability of the disclosed invention over the listed documents, should one or more of the documents be applied against the claims of the present application.



Applicant : Byron Hourmand
For : CAPACITIVE RESPONSIVE ELECTRONIC SWITCHING CIRCUIT
Page : 2

If there is any fee due in connection with the filing of this Statement, please charge the fee to our Deposit Account No. 16-2463.

Respectfully submitted,

BYRON HOURMAND

By: Price, Heneveld, Cooper,
DeWitt & Litton

4-25-96
Date

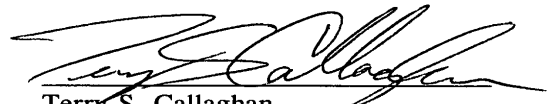
Terry S. Callaghan
Registration No. 34 559
695 Kenmoor, S.E.
P.O. Box 2567
Grand Rapids, MI 49501
(616) 949-9610

TSC/ras

0300

FILED
PATENT
NAR01 P-3109-28-96
J. Wind

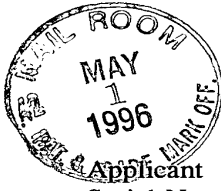

IN THE UNITED STATES PATENT AND TRADEMARK OFFICE

Applicant : Byron Hourmand
Serial No. : 08/601,268 (unofficial)
Filing Date : January 31, 1996 (unofficial)
For : CAPACITIVE RESPONSIVE ELECTRONIC SWITCHING CIRCUIT

Hon. Commissioner of Patents and Trademarks
Washington, D.C. 20231

Dear Sir:

CERTIFICATE OF MAILING

I hereby certify that the attached PTO Form 1449, Information Disclosure Statement Under 37 C.F.R. §1.97(b), Copies of Information Referenced, and Return Postcard are being deposited with the United States Postal Service as first class mail in an envelope addressed to:

Hon. Commissioner of Patents and Trademarks
Washington, D.C. 20231

on 4/25/96.

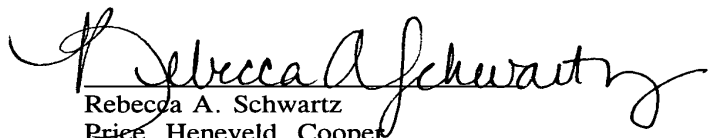
Rebecca A. Schwartz
Price, Heneveld, Cooper,
DeWitt & Litton
695 Kenmoor, S.E.
P.O. Box 2567
Grand Rapids, Michigan 49501
(616) 949-9610



08/601268

PATENT APPLICATION
Attorney Docket No. NAR01 P-310
Express Mail No. RB782578764US

IN THE UNITED STATES PATENT AND TRADEMARK OFFICE

Applicants : Byron Hourmand
For : CAPACITIVE RESPONSIVE ELECTRONIC
SWITCHING CIRCUIT

Box Patent Application
Hon. Commissioner of Patents and Trademarks
Washington, D.C. 20231

Dear Sir:

Enclosed herewith is the above-identified patent application comprising the

following parts:

- 1) Postcard
- 2) Assignment, Assignment Cover Sheet, and Assignment Recording Fee of \$40.00
- 3) Patent Application (60 Total Pages including 6 Pages of Claims (Claims 1-20), and 1 Page of Abstract
- 4) 13 Sheet of Drawings (in duplicate)
- 5) Certificate of Mailing by Express Mail
- 6) Declaration and Power of Attorney
- 7) Verified Statement Claiming Small Entity Status - Small Business
- 8) Information Disclosure Statement, PTO Form 1449 (2 Sheets) and copies of information referenced

Filing Fee:

Basic Fee	\$375.00	\$375.00
Additional Fees		
Each independent claim in excess of three, times \$39.00		\$ 39.00
Number of claims in excess of twenty, times \$11.00		\$000.00
Filing multiple dependent claims per application \$125.00		<u>\$000.00</u>
Total Filing Fee		\$414.00

Applicant : Byron Hourmand
For : CAPACITIVE RESPONSIVE ELECTRONIC
SWITCHING CIRCUIT
Page : 2

A check in the amount of \$414.00 is enclosed to cover the fees noted above.

The Commissioner is hereby authorized to charge payment of the following fees associated with this communication, and during the pendency of this application, or to credit any overpayment, to Deposit Account No. 16-2463. A duplicate copy of this sheet is enclosed.

- 1) Any additional filing fees required under 37 CFR 1.16 for which full payment has not been tendered.
- 2) Any patent application processing fees under 37 CFR 1.17 for which full payment has not been tendered.

Respectfully submitted,

BYRON HOURMAND

By: Price, Heneveld, Cooper,
DeWitt & Litton

1-31-96
Date

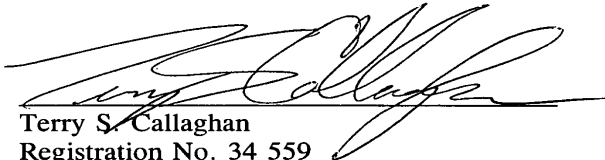
Terry S. Callaghan
Registration No. 34 559
695 Kenmoor, S.E.
P. O. Box 2567
Grand Rapids, MI 49501
(616) 949-9610

TSC/mam
NAR01 P-310



BY
9-28-96
J. Warr

PATENT APPLICATION
Attorney Docket No. NAR01 P-310
Express Mail No. RB782578764US

IN THE UNITED STATES PATENT AND TRADEMARK OFFICE

Applicants : Byron Hourmand *ETAL*
For : CAPACITIVE RESPONSIVE ELECTRONIC
SWITCHING CIRCUIT

Box Patent Application
Hon. Commissioner of Patents and Trademarks
Washington, D.C. 20231

Dear Sir:

Enclosed herewith is the above-identified patent application comprising the

following parts:

- 1) Postcard
- 2) Assignment, Assignment Cover Sheet, and Assignment Recording Fee of \$40.00
- 3) Patent Application (60 Total Pages including 6 Pages of Claims (Claims 1-20), and 1 Page of Abstract
- 4) 13 Sheet of Drawings (in duplicate)
- 5) Certificate of Mailing by Express Mail
- 6) Declaration and Power of Attorney
- 7) Verified Statement Claiming Small Entity Status - Small Business
- 8) Information Disclosure Statement, PTO Form 1449 (2 Sheets) and copies of information referenced

Filing Fee:

Basic Fee	\$375.00	\$375.00
Additional Fees		
Each independent claim in excess of three, times \$39.00		\$ 39.00
Number of claims in excess of twenty, times \$11.00		\$000.00
Filing multiple dependent claims per application \$125.00		<u>\$000.00</u>
Total Filing Fee		\$414.00

Applicant : Byron Hourmand
For : CAPACITIVE RESPONSIVE ELECTRONIC
SWITCHING CIRCUIT
Page : 2

A check in the amount of \$414.00 is enclosed to cover the fees noted above.

The Commissioner is hereby authorized to charge payment of the following fees associated with this communication, and during the pendency of this application, or to credit any overpayment, to Deposit Account No. 16-2463. A duplicate copy of this sheet is enclosed.

- 1) Any additional filing fees required under 37 CFR 1.16 for which full payment has not been tendered.
- 2) Any patent application processing fees under 37 CFR 1.17 for which full payment has not been tendered.

Respectfully submitted,

BYRON HOURMAND

By: Price, Heneveld, Cooper,
DeWitt & Litton

1-31-96
Date

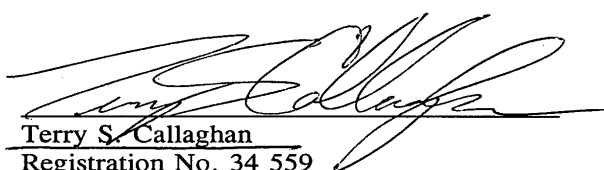
Terry S. Callaghan
Registration No. 34 559
695 Kenmoor, S.E.

P. O. Box 2567
Grand Rapids, MI 49501
(616) 949-9610

TSC/mam
NAR01 P-310

08/601268



PATENT APPLICATION
Attorney Docket No. NAR01 P-310
Express Mail No. RB782578764US

IN THE UNITED STATES PATENT AND TRADEMARK OFFICE

Applicants : Byron Hourmand
For : CAPACITIVE RESPONSIVE ELECTRONIC SWITCHING CIRCUIT

Box Patent Application
Hon. Commissioner of Patents and Trademarks
Washington, D.C. 20231

Dear Sir:

CERTIFICATE OF MAILING BY EXPRESS MAIL

I certify that the attached:

- (1) Return postcard;
- (2) Check in the amount of \$414.00 to cover the Filing Fee;
- (3) Transmittal Letter (in duplicate);
- (4) 60 Pages of Specification including 6 Pages of Claims (20 claims, including 4 independent claims), and 1 Page of Abstract;
- (5) 13 Sheets of Drawings, 25 Figures (in duplicate);
- (6) Information Disclosure Statement, Form PTO-1449 (2 Sheets), and copies of information referenced
- (7) Declaration and Power of Attorney;
- (8) Assignment, Assignment Cover Sheet, and Assignment Recording Fee of \$40.00; and
- (9) Verified Statement Claiming Small Entity Status - Small Business

are being deposited with the United States Postal Service as Express Mail in an envelope having Express Mail Mailing Label Number RB782578764US addressed to:

Box Patent Application
Hon. Commissioner of Patents and Trademarks
Washington, D.C. 20231

on January 31, 1996.

Melissa A. Mahaney
Price, Heneveld, Cooper,
DeWitt & Litton
695 Kenmoor, S.E.
P.O. Box 2567
Grand Rapids, Michigan 49501
(616) 949-9610

TSC/mam

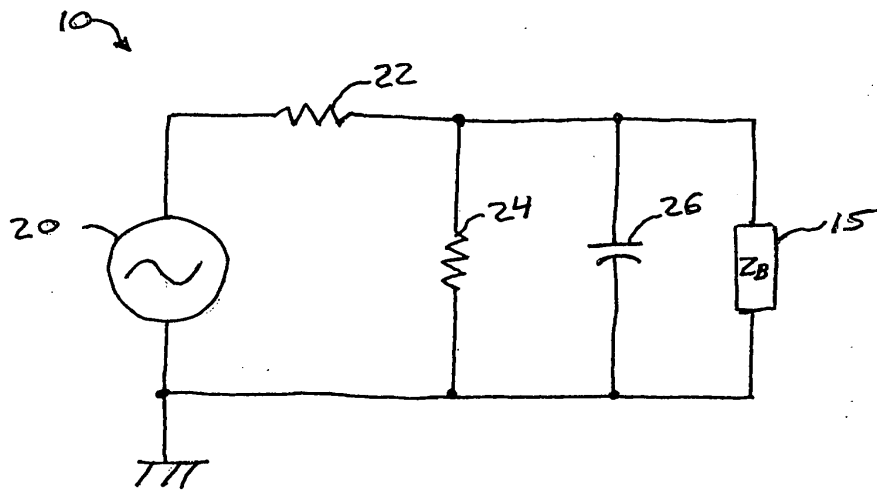

FIG. 1

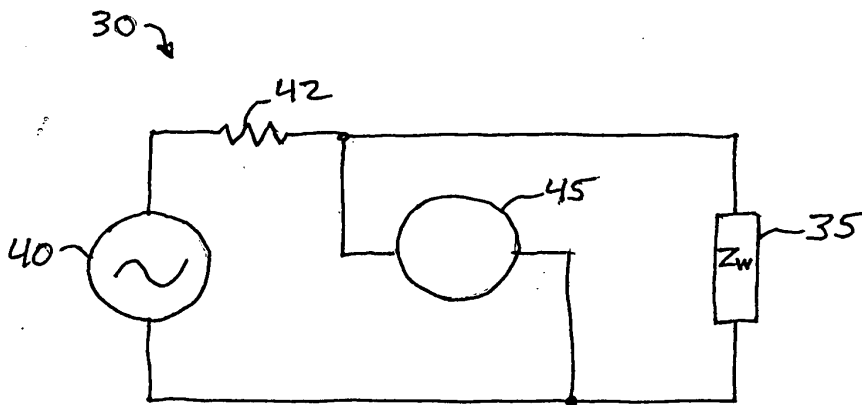

FIG. 2

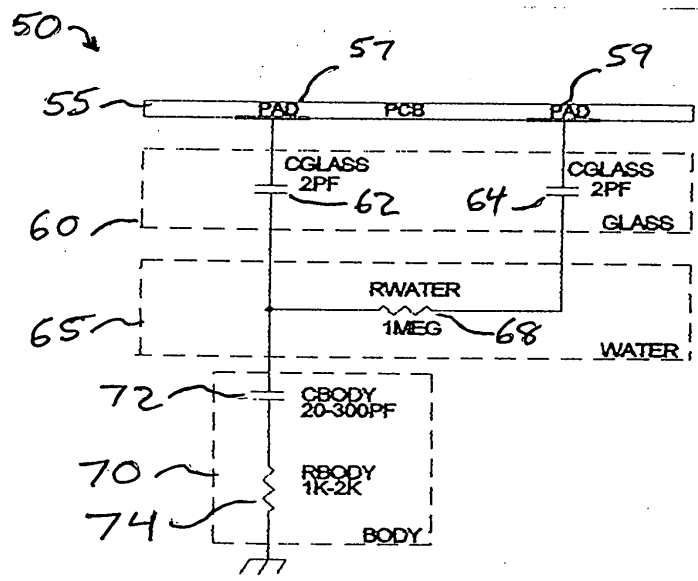

FIG. 3

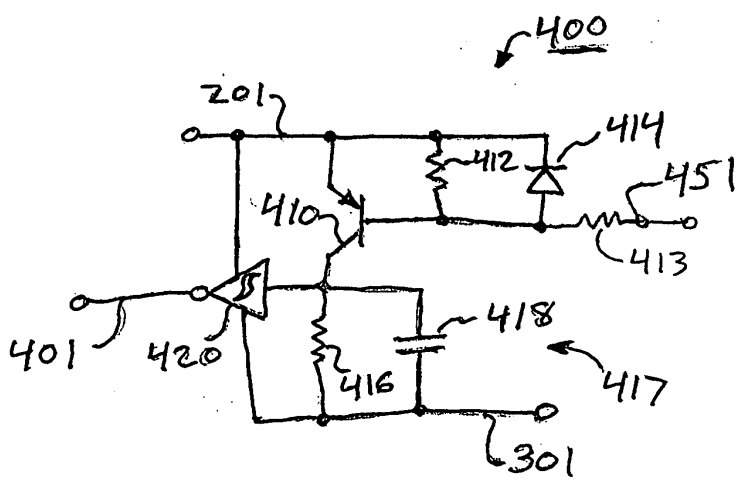

FIG. 8

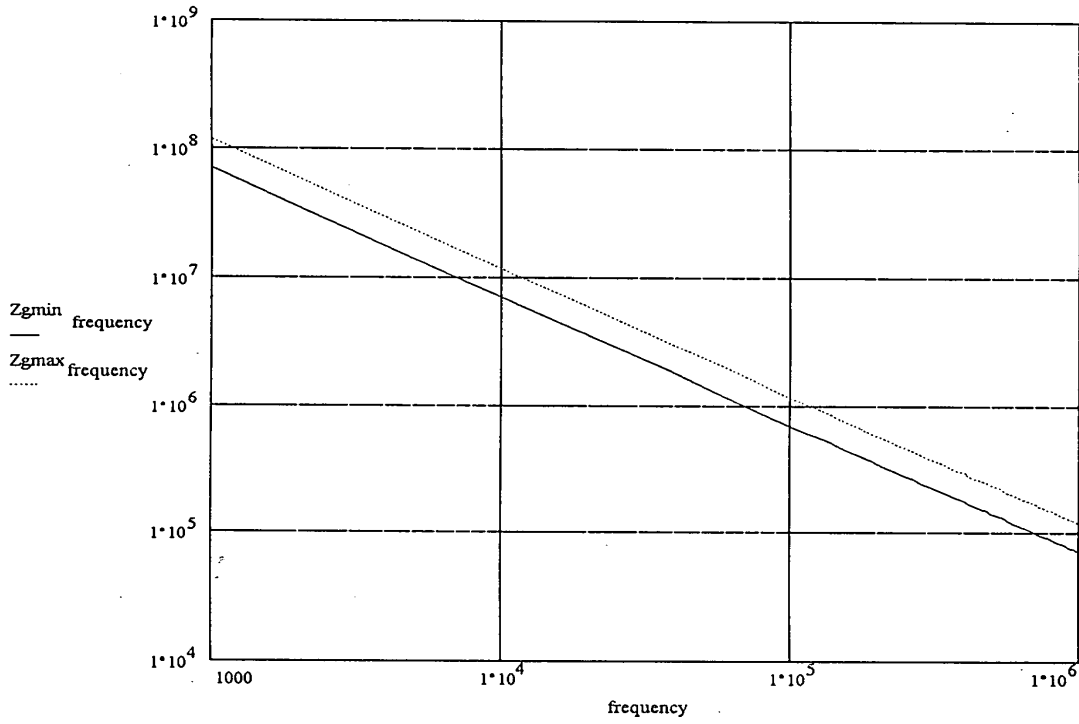

FIG. 3A

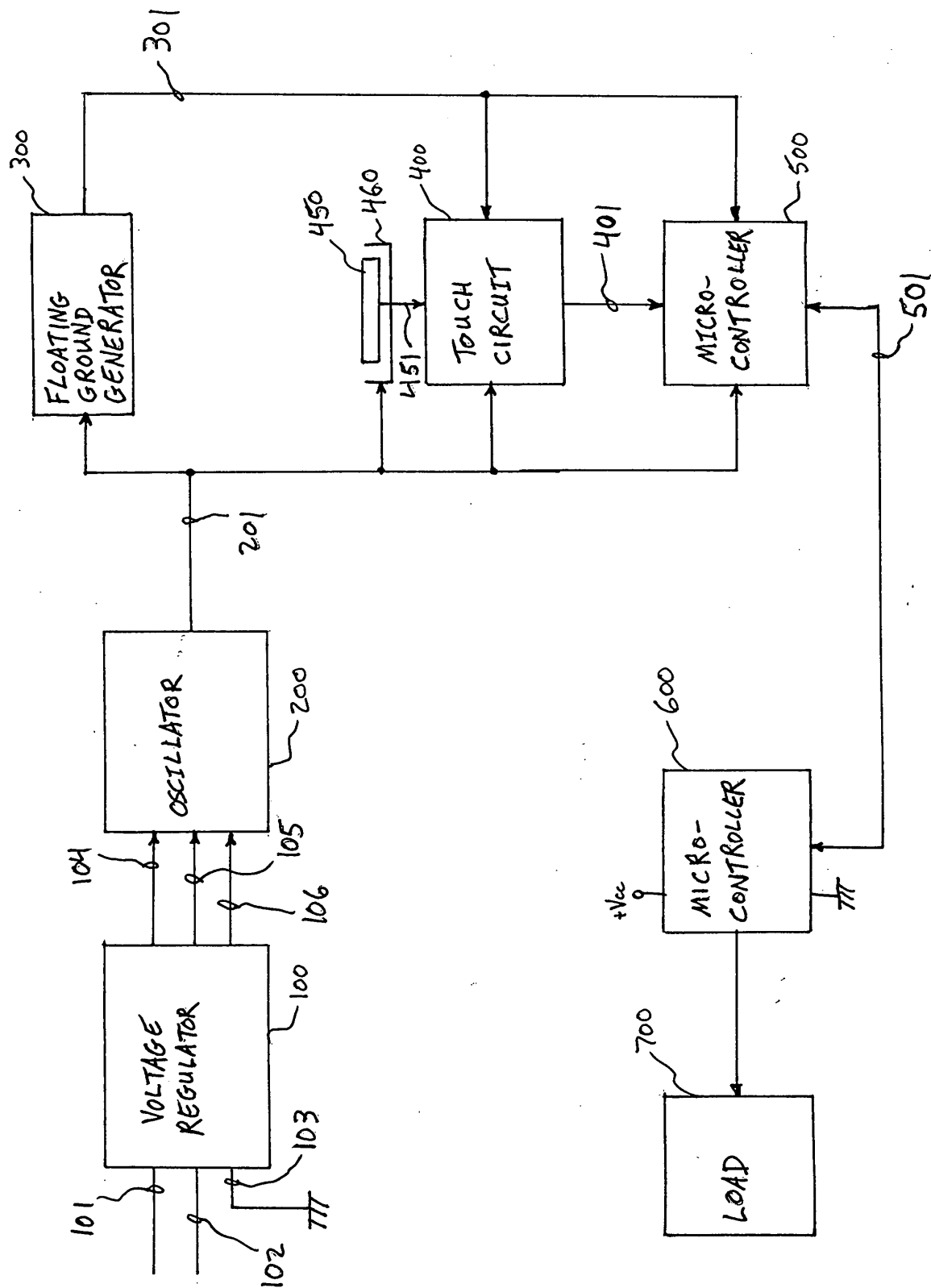

FIG. 4

FIG. 5

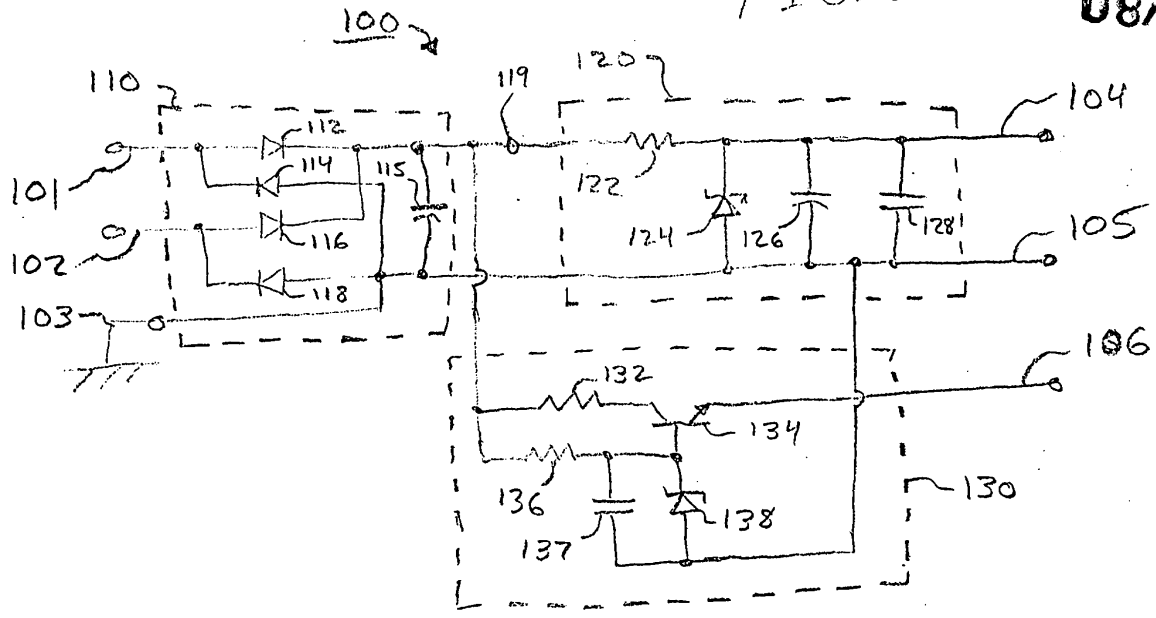

FIG. 6

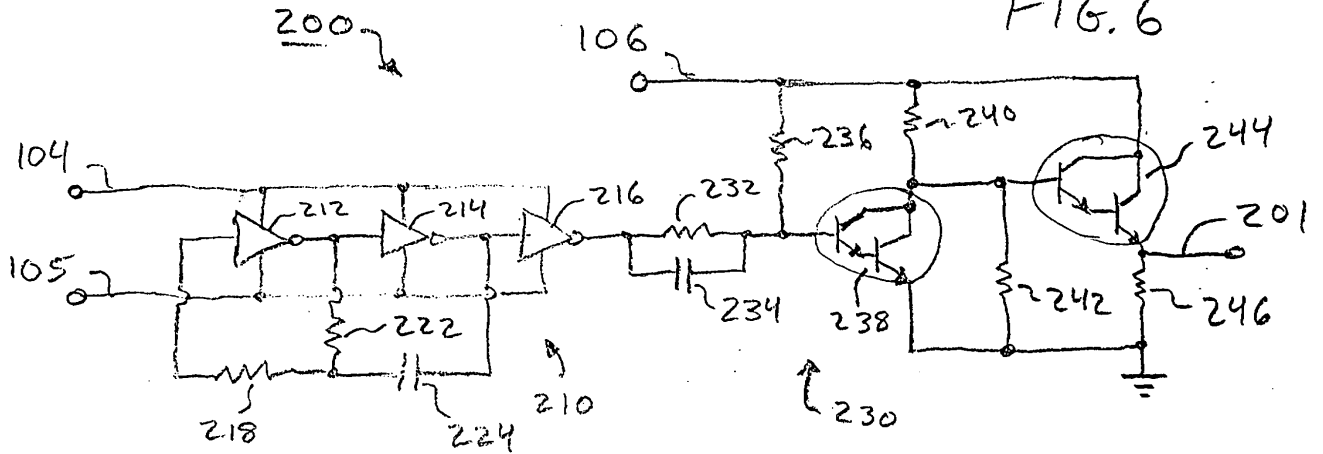
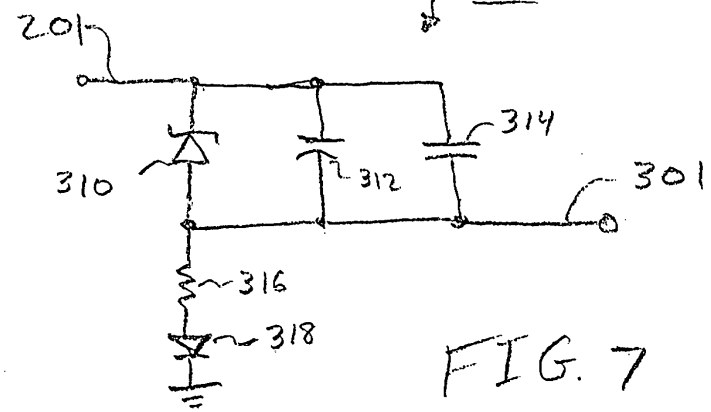

FIG. 7



S/N VS. BODY CAPACITANCE
TEMPERATURE = 105°C

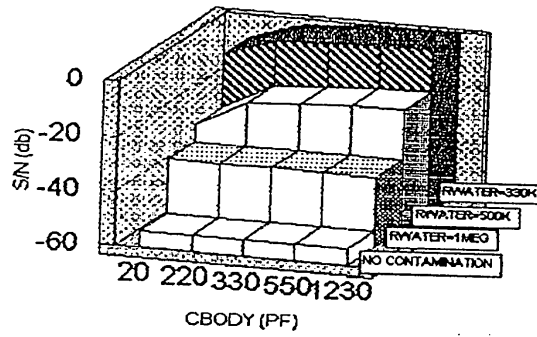

FIG. 9

S/N VS. BODY CAPACITANCE
TEMPERATURE = 25°C

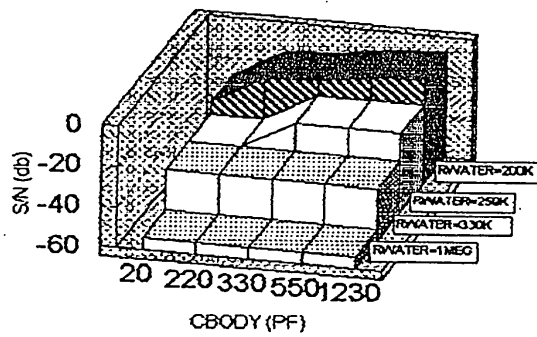

FIG. 10

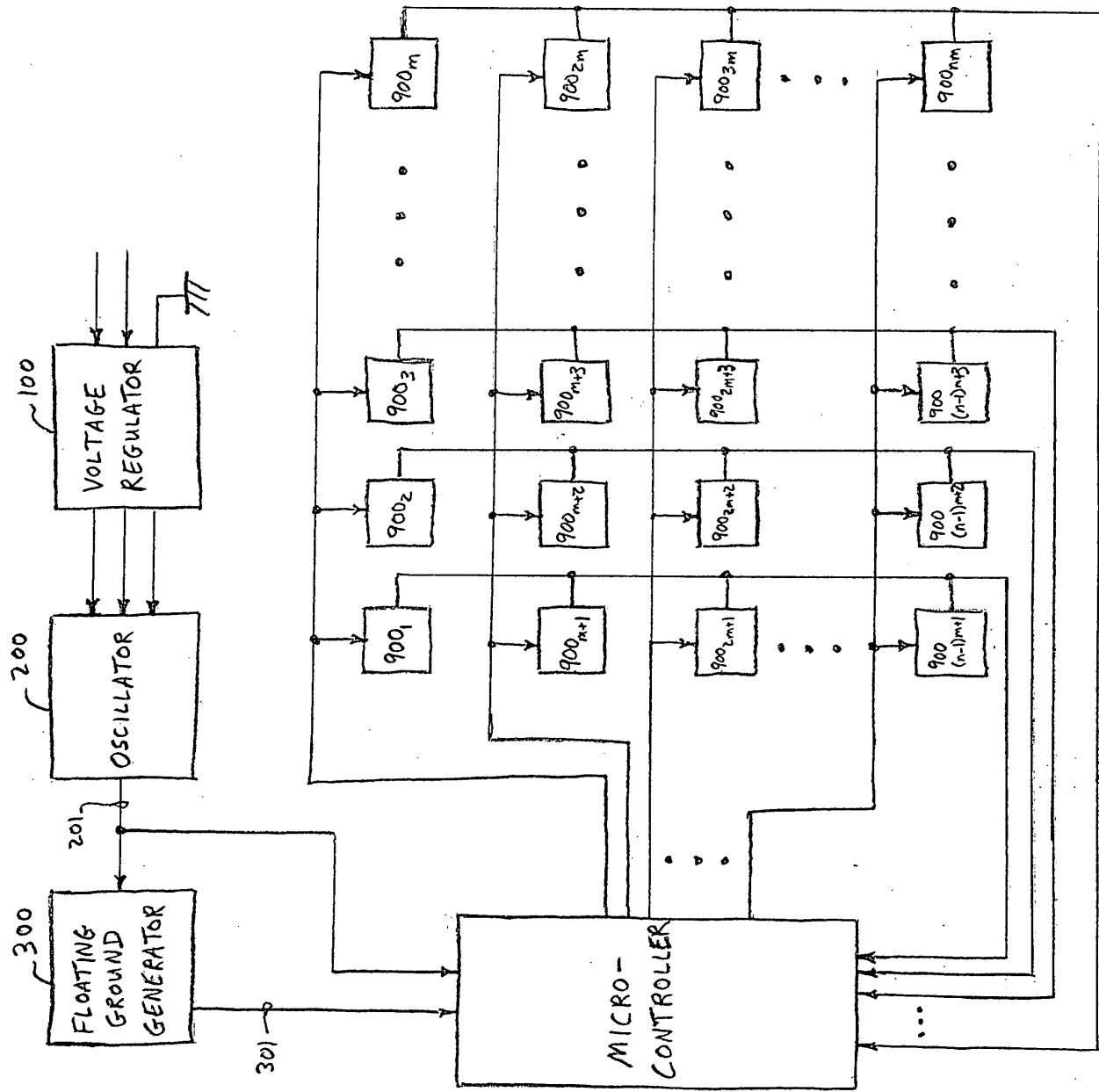

FIG. 11

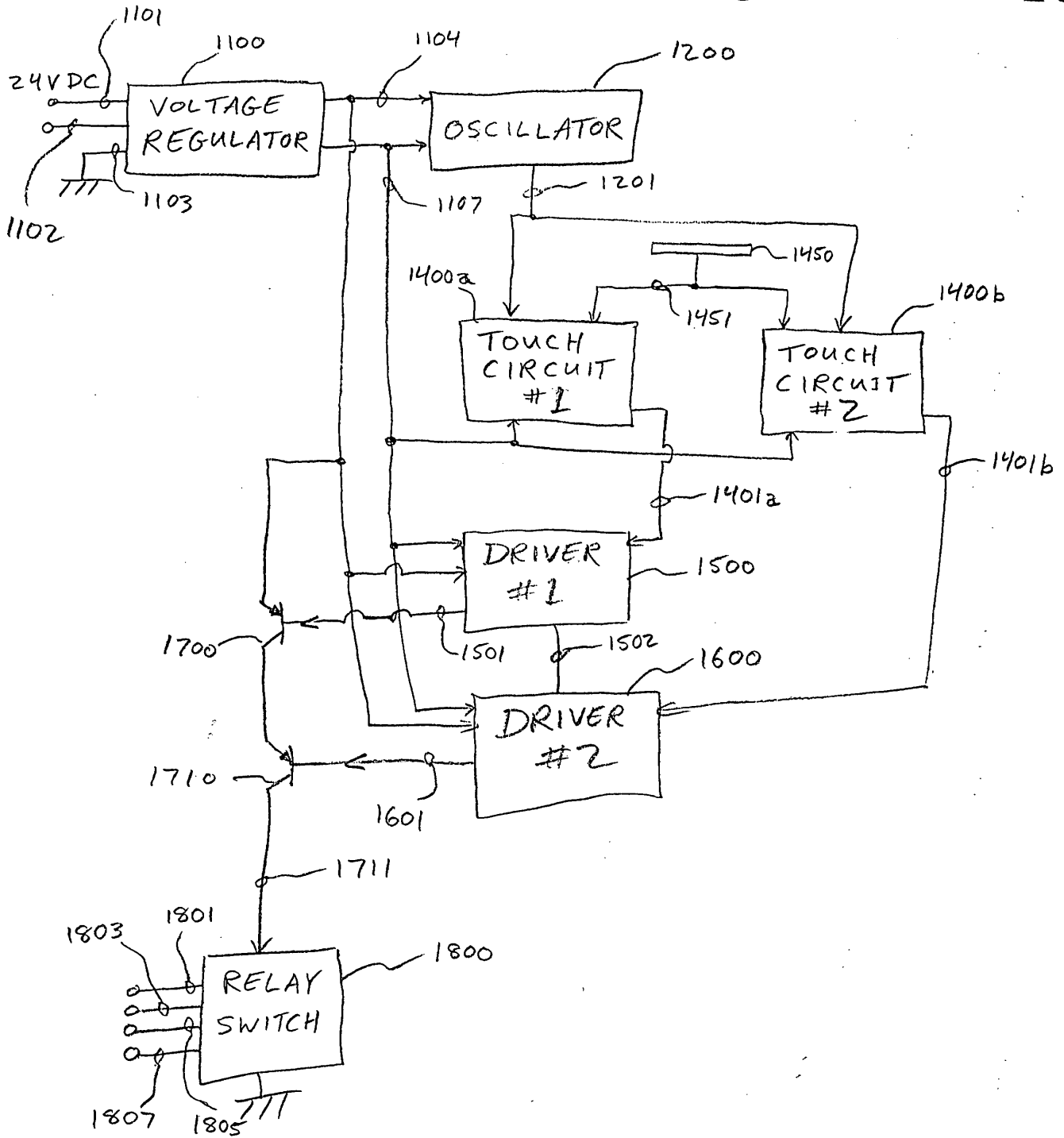

FIG. 12

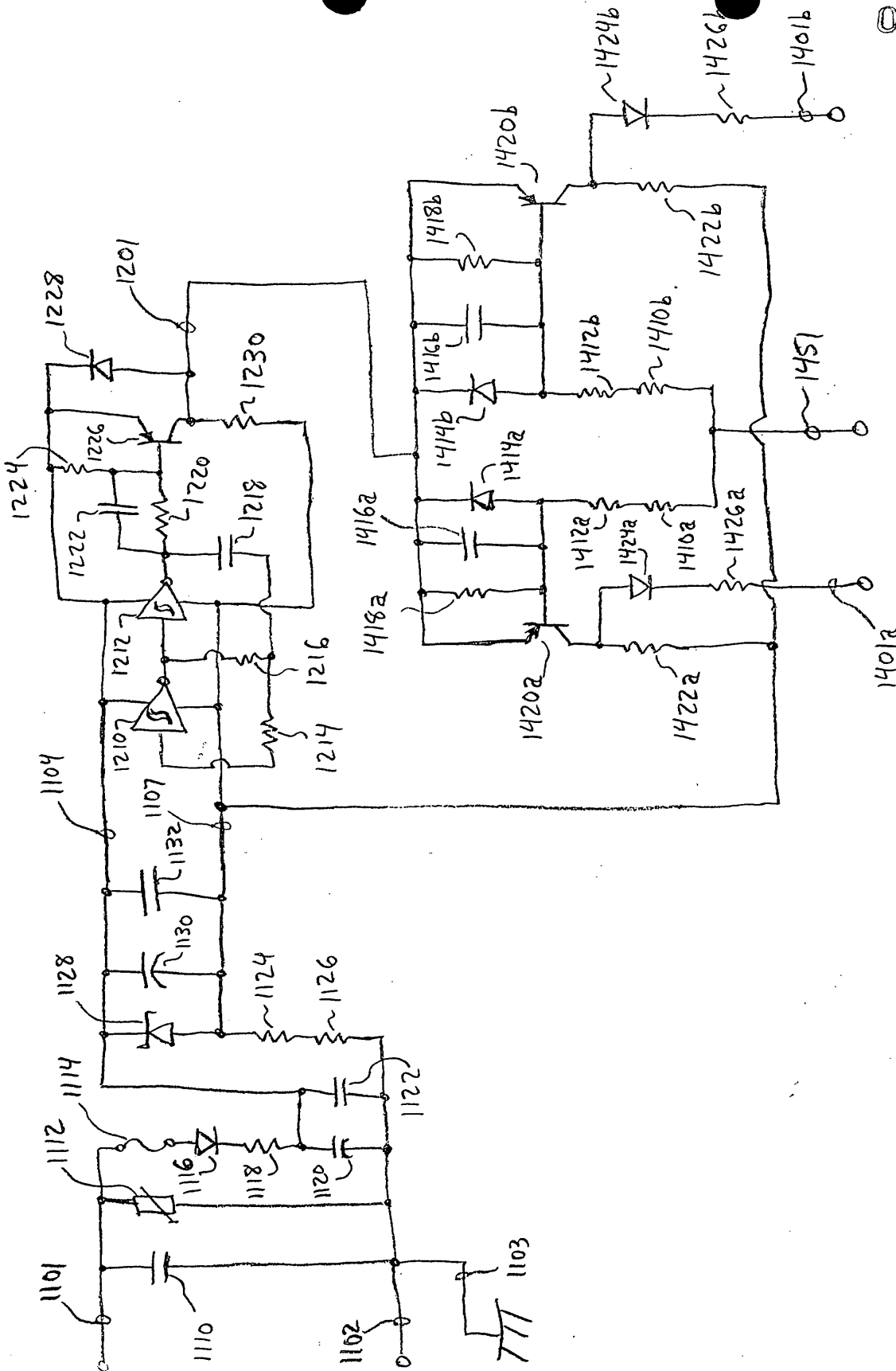

FIG. 13

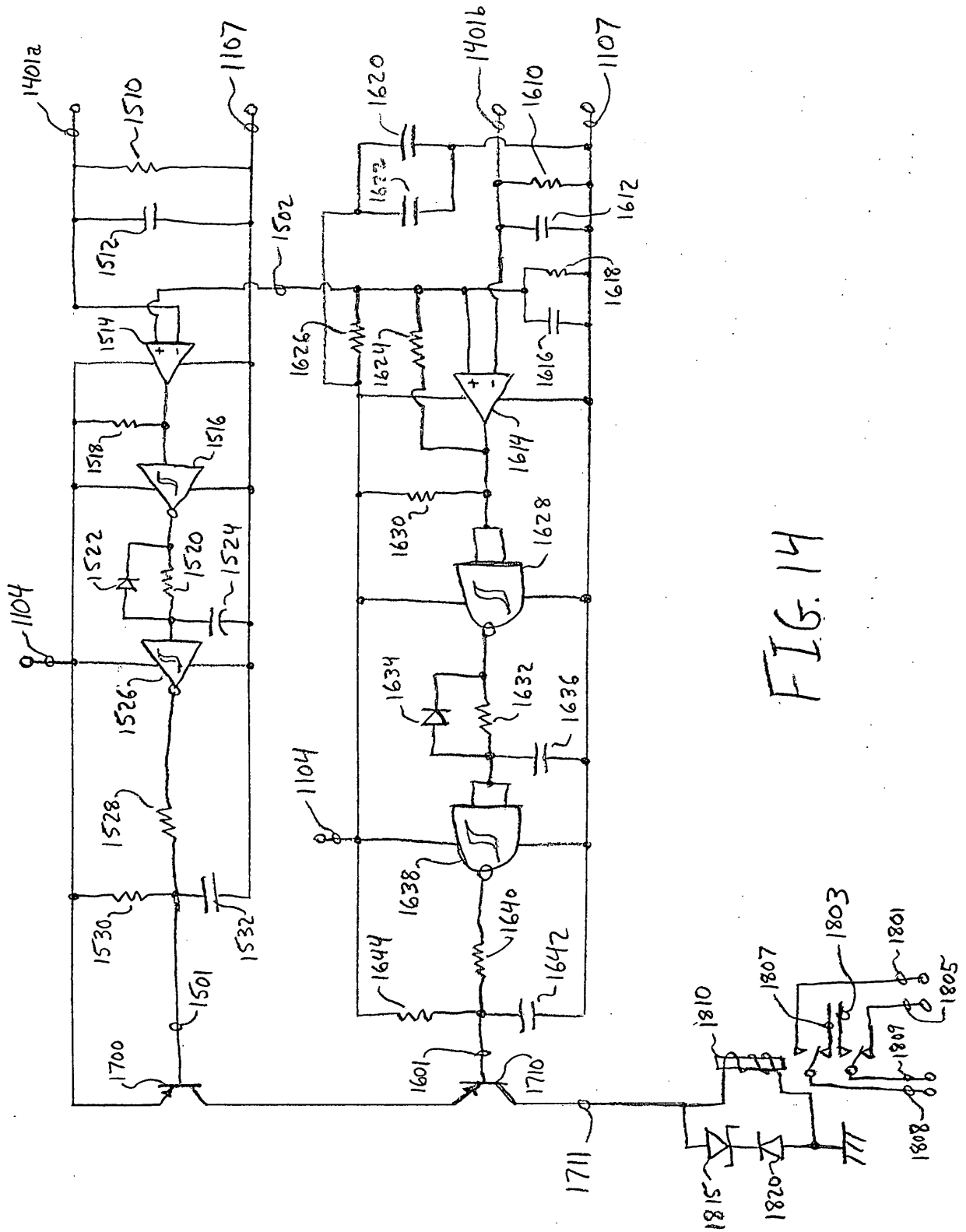

FIG. 14

FIG. 15A

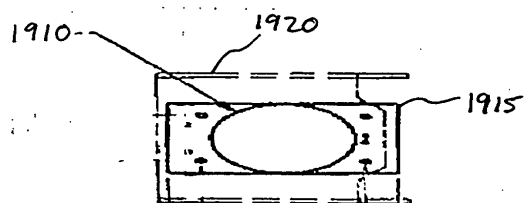

FIG. 15B

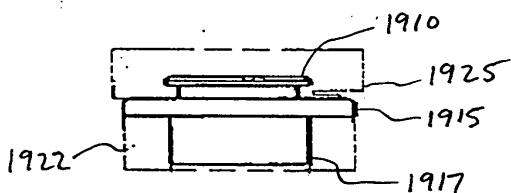
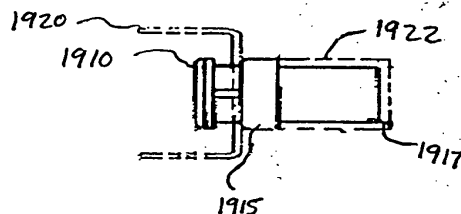

FIG. 15C

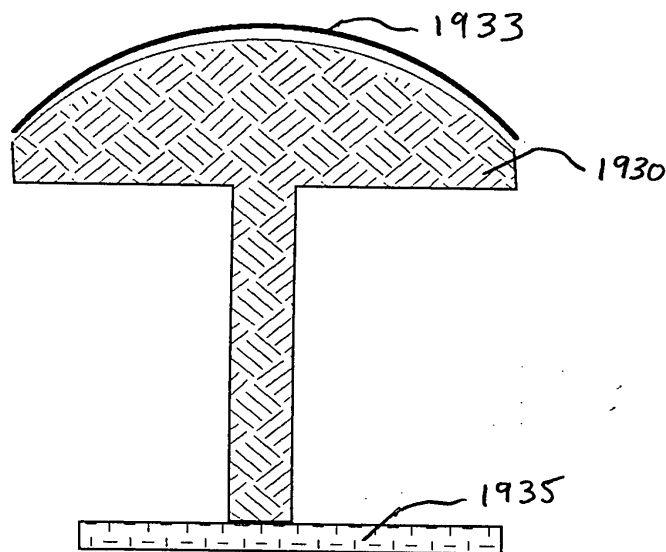

FIG. 16

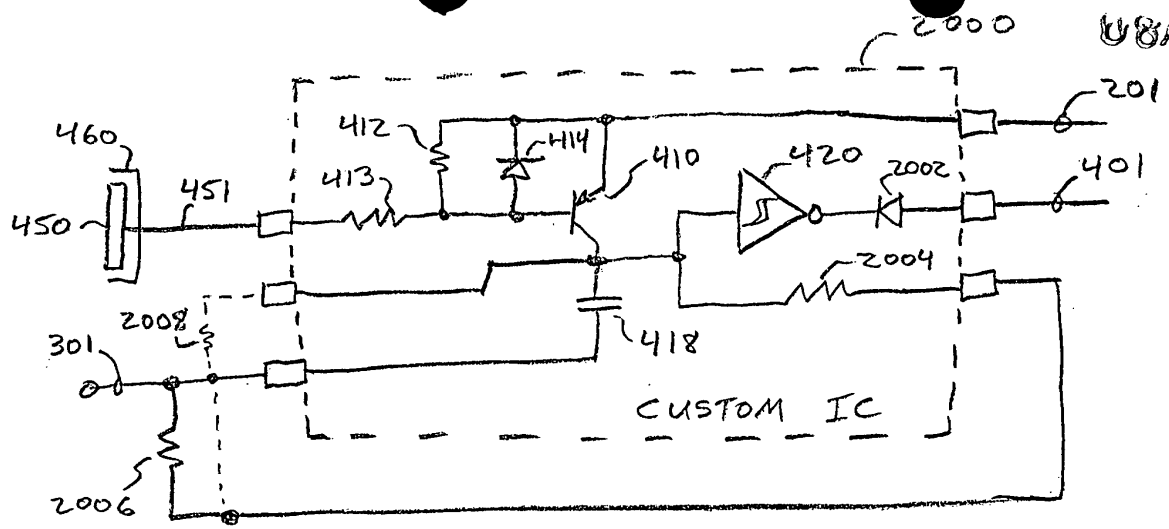

FIG. 17

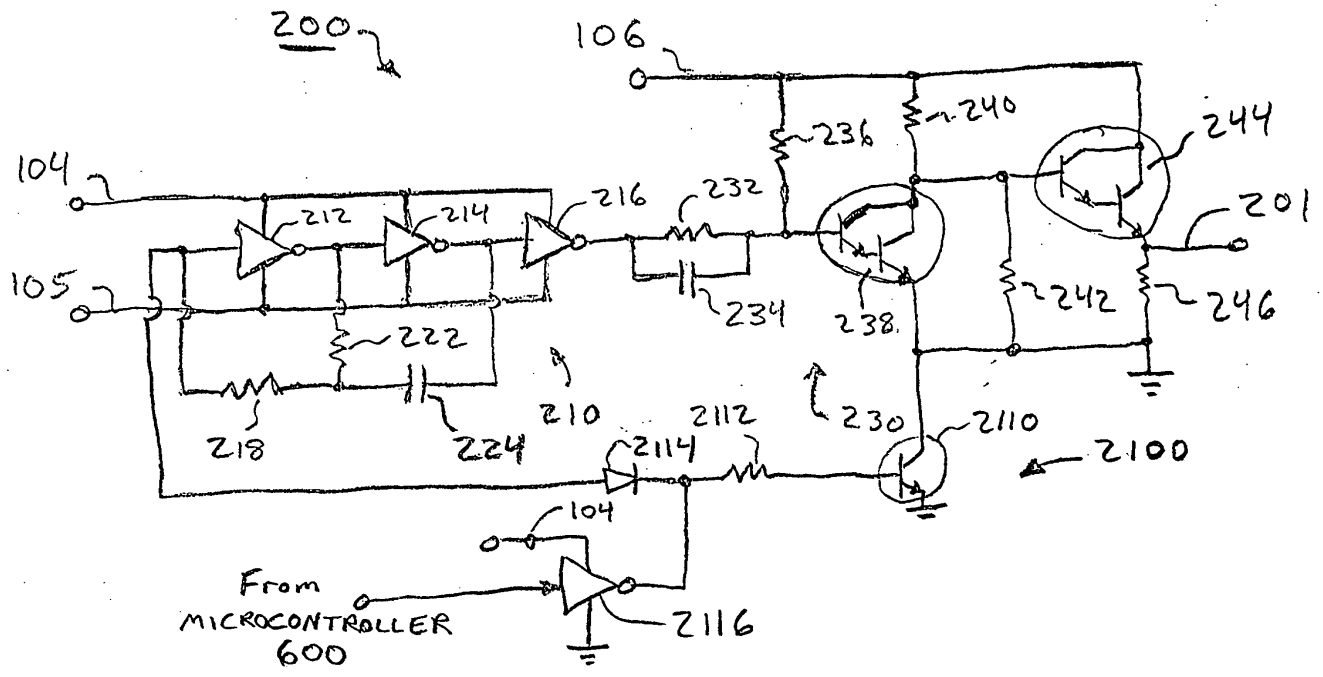

FIG. 18

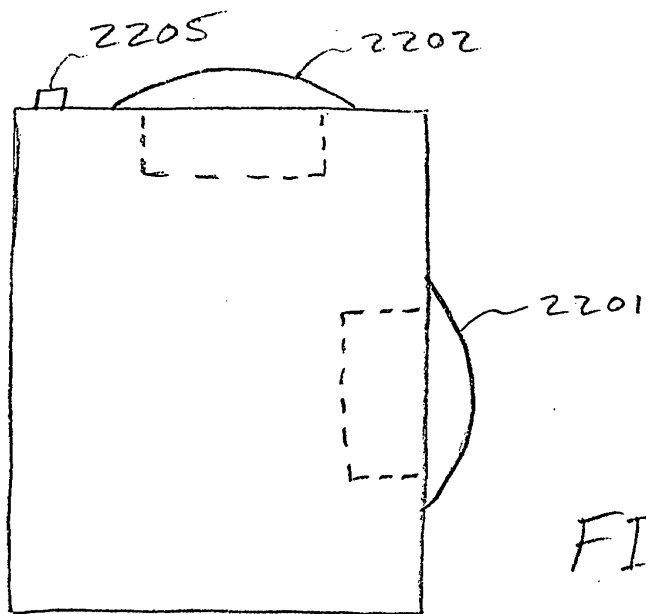

FIG. 19

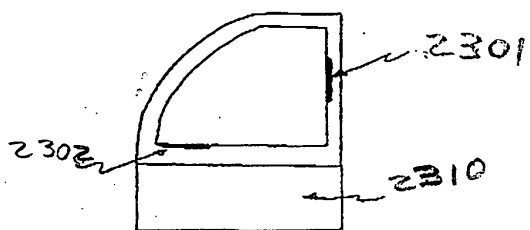

FIG. 20A

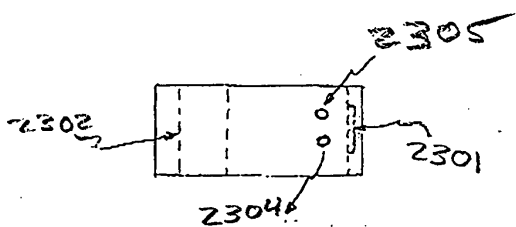

FIG. 20B

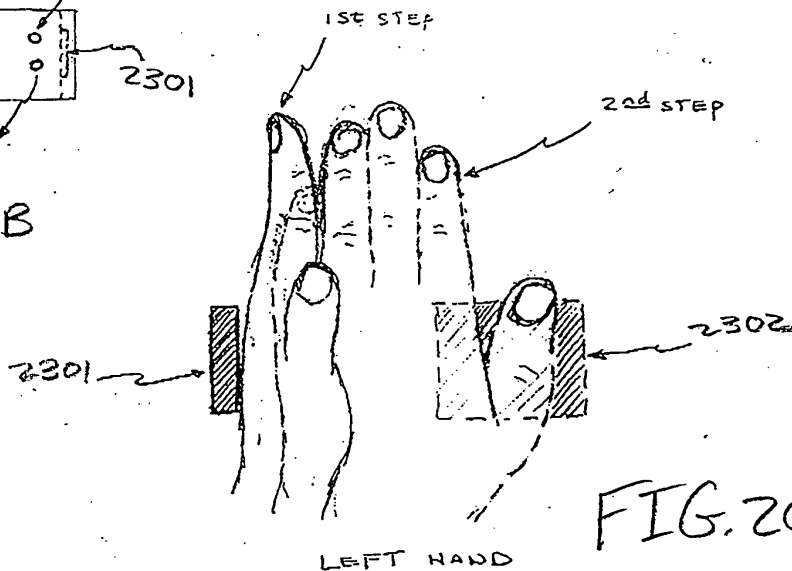

FIG. 20C

LEFT HAND



414-201

A
08/601268
✓

PATENT APPLICATION
Attorney Docket No. NAR01 P-310
Express Mail No. RB782578764US

CAPACITIVE RESPONSIVE ELECTRONIC
SWITCHING CIRCUIT

BACKGROUND OF THE INVENTION

The present invention relates to an electrical circuit and particularly a capacitive responsive electronic switching circuit used to make possible a "zero force" manual electronic switch.

5 Manual switches are well known in the art existing in the familiar forms of the common toggle light switch, pull cord switches, push button switches, and keyboard switches among others. The majority of such switches employ a mechanical contact that "makes" and "breaks" the circuit to be switched as the switch is moved to a closed or an open condition.

a 10 Switches that operate by a mechanical contact have a number of well known problems. First, mechanical movement^a of components within any mechanism make those components susceptible to wear, fatigue, and loosening. This is a progressive problem that occurs with use and leads to eventual failure when a sufficient amount of movement has occurred.

15 Second, a sudden "make" or "break" between conductive contacts typically produces an electrical arc as the contacts come into close proximity. This arcing action generates both radio frequency emissions and high frequency noise on the line that is switched.

Third, the separation between contacts that occurs on each break, exposes the

contact surfaces to corrosion and contamination. A particular problem occurs when the arc associated with a "make" or "break" occurs in an oxidizing atmosphere. The heat of the arc in the presence of oxygen facilitates the formation of oxides on the contact surfaces. Once exposed, the contact surfaces of mechanical switches are also vulnerable to contaminants. Water borne contaminants such as oils and salts can be a particular problem on the contact surfaces of switches. A related problem occurs in that the repeated arcing of mechanical contact can result in a migration of contact materials away from the area of the mechanical contact. Corrosion, contamination, and migration operating independently or in combination often lead to eventual switch failure where the switch seizes in a closed or opened condition.

An additional problem results from the mechanical force required in operating a mechanical switch. This problem occurs in systems where a human operator is required to repetitively operate a given switch or a number of switches. Such repetitive motions commonly occur in the operation of electronic keyboards such as those used with computers and in industrial switches such as used in forming and assembly equipment among other applications.

A common type of industrial switch is the palm button seen in pressing and insertion equipment. For safety purposes, the operator must press the switch before an insertion or pressing can occur. This ensures that the operators hand(s) ^(arc) is on the button(s) and not in the field of motion of the associated machinery. It also ensures that the mechanical motion occurs at a desired and controllable point in time. The difficulty arises from the motion and force required of the operator. In recent years, it has been noted that repeated human motions can result in

debilitating and painful wear on joints and soft tissues yielding arthritis like symptoms. Such repetitive motion may result in swelling and cramping in muscle tissues associated with conditions such as Carpal Tunnel Syndrome. Equipment designers combat these Repetitive Motion or Cumulative Trauma Disorders by adopting ergonomic designs that more favorably control the range, angle, number, and force of motions required of an operator as well as the number of the operator's muscle groups involved in the required motions. Prosthetics and tests are used as well to provide strain relief for the operator's muscles, joints, and tendons.

In mechanical switches, the force required to actuate the switch may be minimized by reducing spring forces and frictional forces between moving parts. However, reducing such forces makes such switches more vulnerable to failure. For instance, weaker springs typically lower the pressure between contacts in a "make" condition. This lower contact pressure increases the resistance in the switch which can lead to fatal heating in the switch and/or loss of voltage applied to the switched load. Reducing frictional forces in the switch by increasing the use of lubricants is undesirable because the lubricants can migrate and contaminate the contact surfaces. A switch designer may also reduce friction by providing looser fits between moving parts. However, looser fits tend to increase wear and contribute to earlier switch failure. A designer can also reduce friction by using higher quality, higher cost, surface finishes on the parts. Thus, as apparent from the foregoing description, measures taken to reduce actuator force in mechanical switch parts generally reduce the reliability and performance of the switch and/or increase the cost of the switch.

In applications such as computer keyboards or appliance controls, the electric load switched by a given switch can be quite low in terms of current and/or voltage. In such cases it is possible to use low force membrane switches such as described in U.S. Patent No. 4,503,294. Such switches can relieve operator strain and are not as susceptible to arcing
5 problems because they switch small loads. However, the flexible membrane remains susceptible to wear, corrosion, and contamination. Although such switches require very low actuation force, they are still mechanically based and thus suffer from the same problems as any other mechanical switch.

A more recent innovation is the development of "zero force" touch switches.
10 These switches have no moving parts and no contact surfaces that directly switch loads. Rather, these switches operate by detecting the operator's touch and then use solid state electronics to switch the loads or activate mechanical relays or triacs to switch even larger loads. Approaches include optical proximity or motion detectors to detect the presence or motion of a body part such as in the automatic controls used in urinals in some public rest rooms or as disclosed in
15 U.S. Patent No. 4,942,631. Although these non-contact switches are by their very nature truly zero force, they are not practical where a multiplicity of switches are required in a small area such as a keyboard. Among other problems, these non-contact switches suffer from the comparatively high cost of electro-optics and from false detections when the operator's hand or other body part unintentionally comes close to the switch's area of detection. Some optical touch
20 keyboards have been proposed, but none have enjoyed commercial success due to performance

and/or cost considerations.

A further solution has been to detect the operator's touch via the electrical conductivity of the operator's skin. Such a system is described in U.S. Patent No. 3,879,618. Problems with this system result from variations in the electrical conductivity of different operators due to variations in sweat, skin oils, or dryness, and from variable ambient conditions such as humidity. A further problem arises in that the touch surface of the switch that the operator touches must remain clean enough to provide an electrical conductivity path to the operator. Such surfaces can be susceptible to contamination, corrosion, and/or a wearing away of the conductive material. Also, these switches do not work if the operator is wearing a glove. Safety considerations also arise by virtue of the operators placing their body in electrical contact with the switch electronics. A further problem arises in that such systems are vulnerable to contact with materials that are equally or more conductive than human skin. For instance, water condensation can provide a conductive path as good as that of an operator's skin, resulting in a false activation.

A common solution used to achieve a zero force touch switch has been to make use of the capacitance of the human operator. Such switches, which are hereinafter referred to as capacitive touch switches, utilize one of at least three different methodologies. The first method involves detecting RF or other high frequency noise that a human operator can capacitively couple to a touch terminal when the operator makes contact such as is disclosed in U.S. Patent No. 5,066,898. One common source of noise is 60 Hz noise radiated from

commercial power lines. A drawback of this approach is that radiated electrical noise can vary in intensity from locale to locale and thereby cause variations in switch sensitivity. In some cases, devices implemented using this first method, rely on conductive contact between the operator and the touch terminal of the switch. As stated, such surfaces are subject to contamination, corrosion, and wear and will not work with gloved hands. An additional problem can arise in the presence of moisture when multiple switches are employed in a dense array such as a keyboard. In such instances, the operator may touch one touch terminal, but end up inadvertently activating others through the path of conduction caused by the moisture contamination.

A second method for implementing capacitive touch switches is to couple the capacitance of the operator into a variable oscillator circuit that outputs a signal having a frequency that varies with the capacitance seen at a touch terminal. An example of such a system is described in U.S. Patent No. 5,235,217. Problems with such a system can arise where conductive contact with the operator is required and where the frequency change caused by a touch is close to the frequency changes that would result from unintentionally coming into contact with the touch terminal.

Another method for implementing capacitive touch switches relies on the change in capacitive coupling between a touch terminal and ground. Systems utilizing such a method are described in U.S. Patent No. 4,758,735 and U.S. Patent No. 5,087,825. With this methodology the detection circuit consists of an oscillator (or AC line voltage derivative)

providing a signal to a touch terminal whose voltage is then monitored by a detector. The touch terminal is driven in electrical series with other components that function in part as a charge pump. The touch of an operator then provides a capacitive short to ground via the operator's own body capacitance that lowers the amplitude of oscillator voltage seen at the touch terminal.

5 A major advantage of this methodology is that the operator need not come in conductive contact with the touch terminal but rather only in close proximity to it. A further advantage arises in that the system does not rely upon radiated emissions picked up by the operator's body which can vary with locale, but relies instead upon the human body's capacitance, which can vary over an acceptable range of 20pF to 300pF.

10 An additional consideration in using zero force switches resides in the difficulties that arise in trying to employ dense arrays of such switches. Touch switches that do not require physical contact with the operator but rather rely on the operator's close proximity can result in unintended actuations as an operator's hand or other body part passes in close proximity to the touch terminals. Above-mentioned U.S. Patent No. 5,087,825 employs conductive guard
15 rings around the conductive pad of each touch terminal in an effort to decouple adjacent touch pads and prevent multiple actuations where only a single one is desired. In conjunction with the guard rings, it is also possible to adjust the detection sensitivity by adjusting the threshold voltage to which the sensed voltage is compared. The sensitivity may be adjusted in this manner to a point where the operator's body part, for instance, a finger, has to entirely overlap a touch
20 terminal and come into contact with its dielectric facing plate before actuation occurs. Although

these methods (guard rings and sensitivity adjustment) have gone a considerable way in allowing touch switches to be spaced in comparatively close proximity, a susceptibility to surface contamination remains as a problem. Skin oils, water, and other contaminants can form conductive films that overlay and capacitively couple adjacent or multiple touch pads. An operator making contact with the film can then couple multiple touch pads to his or her body capacitance and it's capacitive coupling to ground. This can result in multiple actuations where only one is desired. Small touch terminals placed in close proximity by necessity require sensitive detection circuits that in some cases are preferably isolated from interference with the associated load switching circuits that they activate.

As mentioned, in industrial controls, switches can be used to control actuation time and to ensure that the operator's hand(s) or other body part(s) are out of the field of motion of associated machinery. A common type of switch used in this application is the palm button. The button is large enough so that the operator can rapidly bring his or her hand into contact with the button without having to lose the time that would be taken in acquiring and lining up a finger with a smaller switch. Zero force touch switches are also desirable in this application as Repetitive Motion or Cumulative Trauma Disorders have been a problem with operator's utilizing palm buttons -- especially those palm buttons that must be actuated against a spring resistance. In this area capacitive touch switches have also been employed. U.S. Patent No. 5,233,231 is an example of such an implementation. Due to the proximity of machinery with the potential to cause injury, false actuations are a particular liability in such applications.

Capacitive touch switches that exhibit vulnerability to radiated electromagnetic noise or that operate off operator proximity have the potential to actuate when the operator's hand(s) is not at the desired location on the palm button(s). In general, this is addressed by the use of redundancies. In U.S. Patent No. 5,233,231, a separate detector is used to measure RF noise and disable the system to a safe state if excessive RF noise is present. Other systems such as UltraTouch vended by Pinnacle Systems, Inc. use redundant sensing methodologies. In UltraTouch, both optical and capacitive sensors are used and actuation occurs only when both sensor types detect the operator's hand at the desired location. These implementations have a number of disadvantages. In the case of the RF noise detection system, the system is unusable in the presence of RF noise. This forces the user to employ a backup mechanical switch system or accept the loss of function when RF noise is present. The second system is less reliable and more expensive because it requires two sensor systems to accomplish the same task, i.e., detect the operator. Such system may also suffer from problems inherent in any optical system, namely, susceptibility to blockages in the optical path and the need to achieve and maintain specific optical alignments. A further problem is that this system considerably constrains the angle and direction of motion that the operator must use in activating the switch.

Currently, there are several zero force palm buttons in the market. These products utilize optical and/or capacitive coupling to activate a normally closed (NC) or a normally open (NO) relay, and thereby switching 110 V AC, 220 V AC, or 24 V DC to machine controllers. The UltraTouch by Pinnacle Systems Inc. uses two sensors (infrared &

capacitive) with isolated circuits to activate a relay when a machine operator inserts his hand into a U-shaped sensor actuation tunnel. The company claims that by permitting the machine operator to activate the machine with no force or pressure and with the operator's hand and wrist in the ergonomic neutral position (i.e. 0° wrist joint angle and 100% hand power positions as shown in Figure 1.0-1), hand, wrist, and arm stresses are minimized and contributing elements to Carpal Tunnel Syndrome are negated. After a machine cycle is initiated, the operator must maintain an initial posture until the cycle is completed. A typical cycle time lasts approximately one to two seconds and is repeated about 3000 times daily. This adds up to about one hour to one hour and a half per day while the operator is in the posture. While this module reduces stress on wrist and hand, it strains the muscles in the forearm. Also, because of limited space permitted for the operator to insert his hand, it stresses the operator mentally and reduces productivity by causing fatigue. Furthermore, the infrared emitters and detectors rely on a clean path between the transmitter and receiver and will not operate properly if contaminants block the beam of light.

SUMMARY OF THE INVENTION

The present invention overcomes the above problems by using the method of sensing body capacitance to ground in conjunction with redundant detection circuits. Additional improvements are offered in the construction of the touch terminal (palm button) itself and in the regime of body capacitance to ground detection which minimizes sensitivity to skin oils and

other contaminants. The invention also allows the operator to utilize the system with or without gloves which is a particular advantage in the industrial setting.

The specific touch detection method of the present invention has similarities to the devices of U.S. Patent No. 4,758,735 and U.S. Patent No. 5,087,825. However, significant improvements are offered in the means of detection and in the development of an overall system to employ the touch switches in a dense array and in an improved zero force palm button. The touch detection circuit of the present invention features operation at frequencies at or above 50 kHz and preferably at or above 800 kHz to minimize the effects of surface contamination from materials such as skin oils and water. It also offers improvements in detection sensitivity that allow close control of the degree of proximity (ideally very close proximity) that is required for actuation and to enable employment of a multiplicity of small sized touch terminals in a physically close array such as a keyboard. The circuitry of the present invention minimizes the force required in human operator motions and eliminates awkward angles and other constraints required in those motions. The outer surface of the touch switch typically consists of a continuous dielectric layer such as glass or polycarbonate with no mechanical or electrical feed-throughs. The surface can be shaped to have no recesses that would trap or hold organic material. As a result it is easily cleaned and kept clean and so is ideal for hygienic applications such as medical or food processing equipment.

In a first preferred embodiment the circuit offers enhanced detection sensitivity to allow reliable operation with small (finger size) touch pads. Susceptibility to variations in

Common

a supply voltage and noise are minimized by use of a floating ~~ground~~ and supply that follow the oscillator signal to power the detection circuit. The enhanced sensitivity allows the use of a 26V or lower amplitude oscillator signal applied to the touch terminal and detection circuit. This lower voltage (as compared to the device of U.S. Patent No. 4,758,735) obviates the need for expensive UL ~~approved~~ ^{*listed*} higher voltage construction measures and testing to handle what would

a 5

otherwise be large enough voltages to cause safety concerns. A further advantage of the present invention is seen in the manner in which the touch terminal detection circuit is interfaced to the touch terminals and to external control systems. A dedicated microprocessor referenced to the

a

floating supply and ~~ground~~ ^{*floating common*} of the detection circuit maybe used to cost effectively multiplex a number of touch terminal detection circuits and multiplex the associated touch terminal output signals over a two line optical bus to a dedicated microprocessor referenced to a fixed supply

10

a

and ~~true~~ ground. An additional advantage of the microprocessor is an expanded ability to detect faults, i.e. a pad that is touched for an excessive amount of time that is known *a priori* to be an unlikely mode of operation or two or more pads touched at the same time or in an improper

15

order. Additionally, the microprocessor can be used to distinguish desired multiple pad touches in simultaneous or sequential modes, i.e. two or more switches touched in a given order within a given amount of time. The microprocessor can be used to perform system diagnostics as well.

The microprocessor also allows the use of visual indicators such as LEDs or annunciators such as a bell or tone generator to confirm the actuation of a given touch switch or switches. This

20

is particularly useful in cases where a sequence of actuations is required before an action occurs.

13

The feedback to the operator provided by a visual or audio indicator activated by the microprocessor in response to intermediate touches in a required sequence can minimize time lost and/or frustration on the part of the operator due to failed actuations from partial touches or wrong actuations from touching the wrong pad in a given required sequence or combination of touches. The second microprocessor may be used to communicate with the user's control system. Additional features include a "sleep mode" to minimize power consumption during periods of non-use or power brown outs, and redundant control circuits to facilitate "fail to safe" operation. Another improvement is offered in a means to move much of the cost of the system into simplified custom integrated circuits that allow ease of sensitivity adjustment and assembly.

5

In a second preferred embodiment, an improved palm button is featured. Through the use of a dielectric cover, a large metallic touch terminal can be used that differentiates between the touch of a finger or partial touch and the full touch of a palm. In this way the system avoids false triggers due to inadvertent finger touches or brushing contact with the palm prior or after an intended touch. The second embodiment also features redundant control circuits to facilitate "fail to safe" operation.

10

15

To achieve these and other advantages, and in accordance with the purpose of the invention as embodied and described herein, the capacitive responsive electronic switching circuit comprises an oscillator providing a periodic output signal having a frequency of 50 kHz or greater, an input touch terminal defining an area for an operator provide an input by touch, and a detector circuit coupled to the oscillator for receiving the periodic output signal from the

a

20

oscillator, and coupled to the input touch terminal. The detector circuit being responsive to signals from the oscillator and the presence of an operator's body capacitance ^{to ground} coupled to the touch terminal when touched by an operator to provide a control output signal. Preferably, the oscillator provides a periodic output signal having a frequency of 800 kHz or greater.

5 These and other features, objects, and advantages of the invention may be realized and obtained by means of the instrumentalities and combinations particularly pointed out in the written description and claims hereof, as well as by the appended drawings.

BRIEF DESCRIPTION OF THE DRAWINGS

10 \ Fig. 1 is an electrical schematic of a testing circuit used to measure the impedance of the human body;

 \ Fig. 2 is an electrical schematic of a testing circuit used to measure the impedance of water;

 \ Fig. 3 is an electrical schematic of an equivalent circuit model for analyzing a human body in contact with glass covered with water;

15 \ Fig. 4 is a block diagram of a capacitive responsive electronic switching circuit constructed in accordance with a first embodiment of the present invention;

 \ Fig. 5 is an electrical schematic of a preferred voltage regulator circuit for use in the capacitive responsive electronic switching circuit shown in Fig. 4;

 \ Fig. 6 is an electrical schematic of a preferred oscillator circuit for use in the

capacitive responsive electronic switching circuit shown in Fig. 4;

a \ Fig. 7 is an electrical schematic of a preferred floating ~~ground~~ ^{Common} generator circuit for use in the capacitive responsive electronic switching circuit shown in Fig. 4;

\ Fig. 8 is an electrical schematic of a preferred touch circuit for use in the
5 capacitive responsive electronic switching circuit shown in Fig. 4;

\ Fig. 9 is a three dimensional bar graph illustrating signal-to-noise ratio vs. body capacitance at $T = 105^{\circ}\text{C}$;

\ Fig. 10 is a three dimensional bar graph illustrating signal-to-noise ratio vs. body capacitance at $T = 22^{\circ}\text{C}$;

10 \ Fig. 11 is a block diagram of a capacitive responsive electronic switching circuit constructed in accordance with a second embodiment of the present invention;

\ Fig. 12 is a block diagram of a capacitive responsive electronic switching circuit constructed in accordance with a third embodiment of the present invention;

\ Fig. 13 is an electrical schematic of a preferred voltage regulator, oscillator, and
15 touch circuits for use in the capacitive responsive electronic switching circuit shown in Fig. 12;

\ Fig. 14 is an electrical schematic of preferred driver circuits for use in the capacitive responsive electronic switching circuit shown in Fig. 12;

\ Figs. 15A-C are top, side, and front views, respectively, of an example of a flat palm button constructed in accordance with the present invention;

20 \ Fig. 16 is a cross-sectional view of an example of a dome-shaped palm button

constructed in accordance with the present invention;

Fig. 17 is an electrical schematic of a touch circuit of the present invention implemented in a custom integrated circuit;

Fig. 18 is an electrical schematic of an oscillator having a sleeper circuit for use in the capacitive responsive electronic switching circuits of the present invention;

Fig. 19 is a pictorial view of a device having two palm buttons and an indicator light operated in accordance with the present invention; and

Fig. 20A-C are pictorial views of another embodiment of the device shown in Fig. 19.

DETAILED DESCRIPTION OF THE PREFERRED EMBODIMENTS

As apparent from the above summary, the touch circuit of present invention operates at a higher frequency than prior touch sensing circuits. A move to high frequency operation (> 50 to 800 kHz) is not a benign choice relative to the lower frequency (60 to 1000 Hz) operation seen in existing art such as U.S. Patent No. 4,758,735 and U.S. Patent No. 5,087,825. Higher frequencies require generally more costly, higher speed parts, and often results in the added cost of special design measures to minimize electronic emissions and the introduction of high frequency noise on power supply lines. The preference for using such higher frequencies is based on a study performed to determine if high frequency operation would allow a touch of an operator and conduction via surface contamination films, such as moisture, providing a conductive path from a non-touched area to the touched area. The study also

determined whether a high frequency touch circuit could operate over a sufficiently wide temperature range, an assortment of overlying dielectric layer thicknesses and materials, and in the presence of likely power supply fluctuations. The following calculations and measurements are the results of this study. The results summarize the investigation conducted to reduce crosstalk due to condensation of water on the dielectric member (glass). By increasing the frequency of operation, the impedance of the body-glass combination is reduced as compared to the impedance of water between the touch pads.

The equivalent circuit of body impedance was measured using the testing circuit 10 shown in Fig. 1. Testing circuit 10 includes an oscillator 20 coupled between an ~~external~~ ground plate and a 100 kΩ series resistor 22 and in parallel with a 10 MΩ resistor 24, a 20 pF capacitor 26, and contacts for connecting to a human body identified in the figure as an impedance load 15 having an impedance Z_B representing the body's impedance.

Two types of measurements were taken: one with the person under test standing on a large ground plane i.e., concrete slab; and another while standing on a subfloor. The subfloor was used to simulate a typical northern home, i.e., wood joists with plywood sheeting. Carpeting was used as an added insulation layer. Table 1 below shows the measured body resistance and capacitance for five individuals.

TABLE 1

CONCRETE SLAB	CONCRETE SLAB	SUBFLOOR	SUBFLOOR

T180X

18

1.4kΩ	100pF	1.7kΩ	73pF
1.4kΩ	217pF	1.9kΩ	78pF
1.3kΩ	174pF	1.9kΩ	93pF
1.2kΩ	160pF	1.6kΩ	85pF
1.0kΩ	107pF	1.4kΩ	75pF

5

As apparent from Table 1 above and the discussion to follow, a human body's impedance may be represented by the series combination of a 20-300 pF capacitor and a 1k-2kΩ resistor.

The impedance of water, which is mainly resistive, was measured using the testing circuit 30 shown in Fig. 2. Testing circuit 30 includes an oscillator 40 coupled in series with a 1 MΩ resistor 42 and contacts across which water is applied to define an impedance load 35 having an impedance Z_w , representing the impedance of water. A true RMS voltage meter 45 is connected across the contacts of the impedance load 35.

10

a

The resistance of tap water over a 1x1 inch area and 1/32 inch deep, was measured to be around 160 kΩ.

15

The following calculation is for resistance of rain water where c is the conductivity for rain:

T190X

Eq. 1

$$R = \left(\frac{1}{c \cdot in}\right) \times \left(\frac{L}{A}\right)$$

where,

T200X

$$c = 128 \times 10^{-6} (\Omega \cdot \text{cm})^{-1}$$

$$c_{in} = c \left(\frac{100 \text{cm}}{m} \right) \left(\frac{.0254 m}{in} \right)$$

$$L = 1.0 \text{in}$$

$$A = (1.0) \times \left(\frac{1}{32} \right) = \frac{1}{32} \text{in}^2$$

therefore,

$$R = \left(\frac{1}{325.12 \times 10^{-6}} \right) \times \left(\frac{1.0 \text{in}}{\frac{1}{32} \text{in}^2} \right) = 98.43 \text{k}\Omega$$

However, the thickness of a layer of water condensed on the surface of glass is much less than 1/32 inch and its resistance is higher than that of tap water. For design purposes, a resistance value of 1 M Ω was used to simulate condensed water.

5

The capacitance of a piece of glass measuring 1/2" x 1/2" x 1/4", is approximately 2 pF.

Eq. 2

where,

T210X

$$C = K_{glass} K_a \frac{A(cm^2)}{L(cm)} (\mu F)$$

$$K_a = 0.08842 \times 10^{-6} \text{ for vacuum}$$

$$6.0 < K_{glass} < 10$$

$$A = 0.25 \text{ in}^2$$

$$L = 0.25 \text{ in}$$

therefore,

$$C_{max} = 10 \times 0.08842 \times 10^{-6} \times 2.54 \times 10^{-6} = 2.25 \text{ pF}$$

$$C_{min} = 6 \times 0.08842 \times 10^{-6} \times 2.54 \times 10^{-6} = 1.35 \text{ pF}$$

Table 2 below shows the dielectric constant for several types of glass:

TABLE 2

TYPE OF GLASS	Dielectric Constant (K)
Corning 0010	6.32
Corning 0080	6.75
Corning 0120	6.65

5

Corning 8870	9.5
--------------	-----

The equivalent circuit 50 of body touching the glass with the presence of water is shown in Fig. 3. As shown, the equivalent circuit 50 includes a polycarbon (PCB) plate 55 having at least two pads 57 and 59 formed thereon, a glass plate 60 adjacent to PCB plate 55, water 65 on glass plate 60 spanning at least two touch pad areas, and a body 70 in contact with the water 65 and glass plate 60 at one touch pad area. The impedance of glass plate 60 is approximated by two 2 pF capacitors 62 and 64 connected to pads 57 and 59, respectively. The water 65 is approximated by a 1 M Ω resistor 68 connected between capacitors 62 and 64. The body is represented by a 20-300 pF capacitor 72 coupled at one end to water resistor 68 and glass plate capacitor 62, and by a 1-2 k Ω resistor 74 coupled between the other end of capacitor 72 and an external ground.

Referring to Fig. 3, it can be seen that a human touch opposite pad 57 will couple pad 57 to ground through the capacitance of glass 62 and the series contact with the human body impedance provided by the 20-300 pF capacitance and the 1k -2k Ω resistance of a typical human body. This will have the effect of pulling any voltage on the pad towards ground. Pad 59 will be similarly effected, however it's coupling to ground will not only be through capacitance 64, and the series capacitance and resistance of the human body, but will also be through the ohmic resistance of water on the glass cover between the proximate location of pad 59 and the touched pad 57. Because the human capacitance is considerably greater than the 2 pF capacitance of the

glass, the impedance of the path to ground for pads 57 and 59 will be dominated by the glass and water impedances. If the impedance of the water path is significant compared to that of the glass, then the effect of a touch will be more significant at pad 57 than at pad 59. To overcome the effect of condensation or possible water spills, the impedance of the glass is preferably made as small as is practical compared to the impedance of the water. This allows discrimination between touched and adjacent pads. As the water impedance is primarily resistive and the glass impedance is primarily capacitive, the impedance of the glass will drop with frequency.

Fig. 3A shows the maximum and minimum glass impedance as a function of frequency. The maximum and minimum glass impedances shown were computed as follows:

$$\epsilon_0 = 8.854 \times 10^{-12} \text{C}^2/(\text{nm}^2)$$

10

$$K_{g\min} = 6$$

$$K_{g\max} = 10$$

$$A = 0.25 \text{in}^2$$

$$L = 0.25 \text{in}$$

$$C_{\max} = K_{g\max} \epsilon_0 A / L \quad C_{\max} = 2.249 \text{ pF}$$

15

$$C_{\min} = K_{g\min} \epsilon_0 A / L \quad C_{\min} = 1.349 \text{ pF}$$

$$Z_{g\min\text{frequency}} = 1 / (2\pi C_{\max} \text{frequency})$$

$$Z_{g\max\text{frequency}} = 1 / (2\pi C_{\min} \text{frequency})$$

As can be seen, at 1 kHz, the capacitive impedance of the glass is much greater

than the nominal 1 M Ω of the water bridge between the pads. As a result, at 1 kHz, there would be little difference in the impedance paths to ground of the two adjacent pads when either is touched. This would result in the voltage on both pads being pulled towards ground by comparable amounts. Conversely, at 100 kHz, the glass impedance drops to approximately 1 M Ω resulting in the impedance of the path to ground for pad 59 being twice that of the touched pad 57. For cases where background noise and temperature drifts are comparatively small, a 100 kHz oscillator frequency would allow a sufficiently low detection threshold to be set to differentiate between the signal changes induced at both pads by a human touch opposite a single pad. At 800 kHz, the impedance of the glass drops to 200 k Ω or lower giving a ratio of a greater than 5 to 1 impedance difference between the paths to ground of the touched pad 57 and adjacent pads 59. In fact, the impedance ratio may exceed 10 to 1, as illustrated in the calculation below. This allows the detection threshold for the touched pad to be set ^{well} ~~with~~ below that of an adjacent pad resulting in a much lower incidence of inadvertent actuation of adjacent touch pads to that of the touched pad. Ideally, the frequency of operation would be kept at the 800 kHz of the preferred embodiment or even higher. However, as noted earlier, higher frequency operation forces the use of more expensive components and designs. For applications where thermal drift and electronic noise levels are low, operation at or near 100 kHz may be possible. However, at 10 kHz and below, the impedance of the glass becomes much greater than that of likely water bridges between pads resulting in adjacent pads being effected as much by a touch as the touched pad itself. Although the preferred frequency is ~~preferably~~ at or above

100 kHz, and more preferably at or above 800 kHz, it is conceivable that frequencies as low as 50 kHz could be used provided the frequency creates a difference in the impedance paths of adjacent pads that is sufficient enough to accurately distinguish between an intended touch and the touch of an adjacent pad. Use of frequencies as low as 50 kHz may also be possible
5 depending upon the type of glass or covering or the thickness thereof used for the touch pad. However, in cases where there is little or no surface contamination, the frequency of operation can go well below 50 kHz. Ultimately, the frequency chosen will be a tradeoff between the likelihood of surface contamination and the cost of going to higher frequencies to prevent cross talk due to such contamination. The following analysis illustrates one example of how a
10 frequency may be calculated based on the typical parameters used to construct a touch switch and the typical impedance of a contaminant, such as rain water. In the analysis below a 10 to 1 ratio of water to glass impedance is sought.

To eliminate crosstalk due to condensation of water on the glass, the impedance of body (Z_B) and glass (Z_g) combination must be much lower than impedance of water (Z_w).

15 Since the impedance of glass is much higher than body impedance, Z_g will be considered only.

Therefore,

Eq. 3

$$10 |Z_g| < |Z_w|$$

where,

$$C_{glass} = 2pF \quad Z_w = 1 M\Omega$$

Eq. 4

$$Z_g = \frac{1}{2\pi f C_g} = \frac{7.96 \times 10^{10}}{f}$$

$$10x \left(\frac{7.96 \times 10^{10}}{f} \right) < 1 M\Omega$$

Therefore,

$$f > 796 \text{ kHz}$$

Having provided a basis for the use of higher frequencies, the basic construction of the electronic switching circuit constructed in accordance with a first embodiment of the present invention is now described with reference to Fig. 4. The electronic switching circuit includes a voltage regulator 100 including input lines 101 and 102 for receiving a 24 V AC line voltage and a line 103 for grounding the circuit ~~relative to an external ground such as the earth.~~ Voltage regulator 100 converts the received AC voltage to a DC voltage and supplies a regulated 5 V DC power to an oscillator 200 via lines 104 and 105. Voltage regulator also supplies oscillator 200 with 26 V DC power via line 106. The details of voltage regulator 100 are discussed below with reference to Fig. 5.

Upon being powered by voltage regulator 100, oscillator 200 generates a square wave with a frequency of 50 kHz, and preferably greater than 800 kHz, and having an amplitude of 26 V peak. The square wave generated by oscillator 200 is supplied via line 201 to a floating ~~ground~~ ^{Common} generator 300, a touch pad shield plate 460, a touch circuit 400, and a microcontroller 500. Oscillator 200 is described below with reference to Fig. 6.

Floating ~~ground~~ ^{Common} generator 300 receives the 26 V peak square wave from oscillator 200 and outputs a regulated floating ~~ground~~ ^{Common} that is 5 volts below the square wave output from oscillator 200 and has the same phase and frequency as the received square wave. This floating ~~ground~~ ^{Common} output is supplied to touch circuit 400 and microcontroller 500 via line 301 such that the output square wave from oscillator 200 and floating ~~ground~~ ^{Common} output from floating ~~ground~~ ^{Common} generator 300 provide power to touch circuit 400 and microcontroller 500. Details of floating ~~ground~~ ^{Common} generator 300 are discussed below with reference to Fig. 7.

Touch circuit 400 senses capacitance from a touch pad 450 via line 451 and outputs a signal to microcontroller 500 via line 401 upon detecting a capacitance ^{to ground} at touch pad 450 that exceeds a threshold value. The details of touch circuit 400 are described below with reference to Fig. 8.

Upon receiving an indication from touch circuit 400 that a sufficient capacitance ^{to ground} (typically at least 20 pF) is present at touch pad 450, microcontroller 500 outputs a signal to a load-controlling microcontroller 600 via line 501, which is preferably a two way optical coupling bus. Microcontroller 600 then responds in a predetermined manner to control a load 700.

Having generally described the basic construction of the first embodiment, the preferred detailed construction of the depicted components will now be described with Figs. 5-8. In cases where the number of lines to be switched is low, microcontroller 600 can be replaced by additional optical coupling lines. The number of lines to be switched will dictate whether it is more cost effective to multiplex over a two line optical bus such as line 501 and use a microcontroller to demultiplex, or to use a multiplicity of optical coupling lines. Other considerations such as reliability and power consumption may also affect this choice. In this preferred embodiment, the use of a single pair of optical coupling paths (line 501) and a microcontroller 600, is shown to emphasize the capability to switch a large number of lines.

10 A preferred circuit for implementing a voltage regulator 100 is shown in Fig. 5. Voltage regulator 100 preferably includes an AC/DC convertor 110 for generating 29 V to 36 V unregulated DC on line 119. This unregulated DC power is supplied to a 5 V DC regulator 120 and to a 26 V DC regulator 130. AC/DC convertor 110 includes diodes 112, 114, 116, and 118, which rectify the supplied 24 V AC power provided on power lines 101 and 102. The anode of the first diode 112 is coupled to power line 101 and to the cathode of the second diode 114. The cathode of the first diode 112 is coupled to output line 119. The anode of the second diode 114 is coupled to ground via line 103 and to the anode of the fourth diode 118. The anode of the third diode 116 is coupled to the cathode of the fourth diode 118 and to power line 102. The cathode of the third diode 116 is coupled to line 119 and to the cathode of the first diode 112. The anode of the fourth diode 118 is coupled to ground via line 103. Diodes 112,

114, 116, and 118 are preferably diodes having part no. 1N4002 available from LITEON. AC/DC convertor 110 also preferably includes a capacitor 115 for filtering the rectified output of the diodes. Capacitor 115 is preferably a 1000 μF capacitor coupled between output line 119 and ground via line 103.

5 The 5 V regulator 120 preferably includes a 500 Ω resistor 122 coupled between line 119 and 5 V output line 104, and a zener diode 124, a first capacitor 126, and second capacitor 128 all connected and parallel between output power lines 104 and 105. Preferably, zener diode 124 is a 5.1 V zener diode having part no. 1N4733A available from LITEON, first capacitor 126 has a capacitance of 10 μF , and second capacitor 128 has a capacitance of 0.1 μF .

10 The 26 V regulator 130 preferably includes a transistor 134 having a collector connected to line 119 via a first resistor 132, a base connected to line 119 via a second resistor 136, and an emitter coupled to the regulated 26 V output power line 106. The 26 V regulator 130 also preferably includes a capacitor 137 and zener diode 138 connected in parallel between the base of transistor 134 and ground line 103. Preferably, first resistor 132 is a 20 Ω , 0.5 W resistor, second resistor 136 is a 1 k Ω , 0.5 W resistor, capacitor 137 is a 0.1 μF capacitor, and zener diode 138 is a 27 V, 0.5 W diode having part no. 1N5254B available from LITEON. It will be apparent to those skilled in the art, that various components of voltage regulator 100 may be added or excluded depending upon the source of power available to power the oscillator 200. For example, if the available power is a 110 V AC 60 Hz commercial power line, a transformer
15
20 may be added to convert the 110 V AC power to 24 V AC. Alternatively, if a DC battery is

used, the AC/DC convertor among other components may be eliminated.

A preferred example of an 800 kHz oscillator is shown in Fig. 6. Oscillator 200 preferably includes a square wave generator 210, which is powered by 5 V regulator 120 via lines 104 and 105, for generating a 5 V peak square wave having the desired frequency, and a
5 buffer circuit 230 powered by 26 V regulator 130 via line 106 for buffering the output of square wave generator 210 and boosting its peak from 5 V to 26 V while maintaining the preferred frequency. Square wave generator 210 is preferably an astable multivibrator constructed with at least two serially connected inverter gates 212 and 214, and optionally, a third serially connected inverter gate 216. Inverter gates 212, 214 and 216 are preferably provided in a single
10 integrated circuit designated as part 74HC04 available from National Semiconductor. The output of the first inverter gate 212 is coupled to its input via resistors 218 and 222 and is coupled to the output of the second inverter gate 214 via a capacitor 224. The input of the second inverter gate 214 is ~~coupled~~ ^{directly connected} to the output of the first inverter gate 212 and the output of the second inverter gate 214 is ~~coupled~~ ^{directly connected} to the ~~output of the~~ ^{input of the} optional third inverter gate 216.
15 To provide an 800 kHz output, resistor 218 preferably has a 10.0 kΩ value, resistor 222 preferably has a 1.78 kΩ value, and capacitor 224 is preferably a 220 pF capacitor.

The 5 V peak square wave generated by square wave generator 210 is supplied from either the output of inverter gate 214 or the output of optional inverter gate 216 to the base of a first transistor 238 via a first resistor 232 connected in parallel with a capacitor 234. The base
20 of first transistor 238 is connected to the 26 V regulated DC power line 106 via a second resistor

236. The collector of first transistor 238 is connected to 26 V power line 106 via a third resistor 240 and to the base of a second transistor 244. The emitter of first transistor 238 is coupled to ground and to it's own collector and the base of second transistor 244 via a fourth resistor 242.

The collector of the second transistor 244 is connected directly to 26 V power line 106 and the emitter of second transistor 244 is connected to ground via a fifth resistor 246. Second transistor 244 provides the 26 V peak square wave on output line 201, which is connected to it's emitter. In operation, the square wave signal applied to the base of transistor 238 causes the collector of transistor 238 to swing between ^{near to} the DC supply 106 voltage and the collector-emitter saturation voltage. Capacitor 234 is provided to improve the turning off of transistor 238.

Transistor 244 along with resistors 242 and 246 are used to buffer the square wave signal generated by transistor 238. In a preferred embodiment, the values of the resistors and capacitor are as follows: first resistor 232 is 5.1 kΩ, capacitor 234 is 0.0047 μF, second resistor 236 is 1 MΩ, third resistor 240 is 1.6 kΩ, fourth resistor 242 is 100 kΩ, and fifth resistor 246 is 4.7 kΩ. Preferably, transistors 238 and 244 are those identified as part no. ZTX600 available from

ZETEX. In this configuration, the oscillator 200 sources 80 mA to ~~generate~~ floating 5 V DC ^{to} and power ~~up~~ touch circuits ^(s) 400, microcontroller 500, and Schmitt triggered gates 420 (Fig. 8).

As will be apparent to those skilled in the art, the values of the resistors and capacitors utilized in oscillator 200 may be varied from those disclosed above to provide for different oscillator output frequencies. As discussed above, however, oscillator 200 is preferably constructed so as to output a square wave having a frequency of 50 kHz or greater, and more

preferably, of 800 kHz or greater. In some cases it may be necessary to use lower gain bandwidth product transistors or filtration to achieve a softer roll-off of the square edges to reduce high frequency noise emissions. When this is done the amplitude of the oscillator voltage ^{can} ~~must~~ be increased to compensate.

5 ↙ The preferred construction of floating ground generator 300 is shown in Fig. 7
a ~~and preferably~~ includes a zener diode 310 having a cathode connected to the oscillator output on line 201 and an anode connected to floating ground output line 301 and to ground via resistor 316 and diode 318. Floating ground generator 300 also preferably includes a first capacitor 312 and a second capacitor 314 connected in parallel with zener diode 310. In the preferred
10 embodiment, zener diode 310 is a 5.1 V zener diode identified by part no. 1N4733A available from LITEON, capacitor 312 is a 47 μ F tantalum capacitor, capacitor 314 is a 0.1 μ F capacitor, resistor 316 is a 270 Ω resistor, and diode 318 is a diode identified as part no. 1N914B available from LITEON.

 Touch circuit 400, as shown in Fig. 8, preferably includes a transistor 410 having
15 a base connected to touch pad 450 via resistor 413 and line 451, an emitter coupled to oscillator output line 201, and a collector coupled to floating ground line 301 via a pulse stretcher circuit
a 417, which includes a resistor 416 and a capacitor 418 connected in parallel ~~between the~~
a ~~collector of transistor 410 and floating ground line 301~~. To minimize susceptibility to noise, the
 physical length of the path between the touch pad 450 and the base of the transistor 410, must
20 be held to a minimum. Additionally, RC filters can be placed in line 401 between the output

of the touch circuit 400 and the input of the microcontroller 500 to give additional EMI/RFI immunity. Additionally, the higher the frequency, the higher the gain bandwidth product that is required in transistor 410. The gain bandwidth product must be sufficient to guarantee that the oscillator turns on during oscillator High pulses. A further trade-off is to use higher gain bandwidth product to allow lower oscillator voltages or higher oscillator voltages to all allow a lower gain bandwidth product transistor to be used. The combination of oscillator voltage, frequency and transistor gain bandwidth product that is used will necessarily vary with the cost, safety and reliability requirements of a given application. The present combination was chosen to keep the oscillator voltage down and allow operation at 800 kHz to minimize cross talk. At higher frequencies a higher gain bandwidth product transistor would be required in both the oscillator 200 and detection 400 circuits. Touch circuit 400 also preferably includes a diode 414 having an anode connected to the base of transistor 410 and resistor 413, and a cathode connected to the emitter of transistor 410 and to a resistor 412 connected in parallel with diode 414 between the base and emitter of transistor 410. The pulse stretcher circuit 417 is identified as such because the sensitivity of the touch circuit may be increased or decreased by varying the resistance of resistor 416. ~~Resistor 413 is used to limit the base current.~~

resistor 412 and

to

^

JWS
02/

to

Additionally, touch circuit 400 may include at least one Schmitt triggered gate 420 powered by the voltage difference existing between oscillator line 201 and 301, and having an input terminal coupled to the collector of transistor 410 and an output coupled to microcontroller 500 via output line 401. Schmitt triggered inverter gate 420 is optionally provided to improve

33

the rise time of the touch switch output and to buffer the output. Preferably, transistor 410 is part no. BC858CL available from Motorola, resistor 412 is a 12 M Ω resistor, diode 414 is part no. 1N914B available from Diodes, Inc., resistor 416 is a 470 k Ω resistor, capacitor 418 is a 0.001 μ F capacitor, and resistor 413 is a 10 k Ω resistor.

a 5

As stated above, the operator's body includes a capacitance, which may range in a typical person from between 20 to 300 pF. The base terminal of transistor 410 is coupled to its emitter by resistor 412 such that unless capacitance is present by the user touching the touch pad 450, transistor 410 will not be forward biased and will not conduct. Thus, when touch pad 450 is not touched, the output signal at the collector terminal of transistor 410 and across pulse stretcher circuit 417 will be zero volts. When, however, a person touches the touch pad 450,

to ground
^

10

that person's body capacitance, couples the base of transistor 410 to ~~earth~~ ground 103 through resistor 413, thereby forward biasing transistor 410 into conduction. This charges capacitor 418 providing a positive DC voltage with respect to the line 301 and causes the output of the Schmitt trigger 420 to go low. Diode 414 is coupled across the base to emitter junction of transistor 410

to ground
^

a

15 a

to clamp the base emitter reverse voltage to -0.7 V, ~~thereby reducing~~ the forward recovery and turn-on time.

bias
^ *and also reduce*
^

Touch pad 450 includes a substrate on which a plurality of electrically conductive plate members are mounted on one surface thereof. The substrate is an insulator and the plates are spaced apart in order to insulate the plates from one another and from ground. Also, positioned on the substrate is a guard band, generally shown as 460. Guard band 460 is a grid

20

34

of conductor segments extending between adjacent pairs of plate members. All conductor segments are physically interconnected to define a plurality of spaces with one plate member positioned centrally within each space. Components of the touch circuit may be positioned on the side of substrate opposite plate members and guard band 460.

5 A planar dielectric member is spaced from the substrate facing plate members. The dielectric member is made from a non-porous insulating material such as polycarbonate or glass. A plurality of electrically conductive spring contacts are sandwiched between the inner surface of the dielectric member and the substrate. An indicia layer may be adhered to the inner surface of the dielectric member to provide an indication of the function of each input portion.

10 As mentioned above, interface between the dielectric member and a conductive plate is a metallic spring contact that is attached to the back of the dielectric member. The spring contacts offer advantages at high temperature extremes. However, for sufficiently narrow temperature ranges, conductive polymer foam pads cut to the size of the touch pads are preferably used to fill the gap between conductive pad and dielectric layer. The function of the
15 spring contacts or conductive foam pads is to eliminate that capacitive contribution of the air filled gap between the conductive pads and the overlying dielectric layer.

 A problem with capacity responsive keyboards is the tendency of switches that are closely positioned in a keyboard system to inadvertently become actuated even though the user is touching an adjacent switch. Furthermore, this problem is greatly aggravated by the
20 presence of contamination on the outer surface of dielectric member. Contamination such as

skin oil or moisture causes erratic keyboard operation and multiple switches will turn on even though one switch is touched. By operating at a high frequency such as 100 kHz or 800 kHz, the impedance of the series combination of body and glass capacitance are lowered as compared to the impedance of contamination present on the glass thereby reducing crosstalk.

5 If glass thickness is smaller than 3/16 inch, the touch circuit becomes more sensitive to body capacitance. There are two ways to adjust the sensitivity so that crosstalk does not occur: remove diode 414 and/or reduce the resistance of resistor 416. Increasing the resistance of resistor 416 would allow usage of thicker glass. However, this resistance preferably should not go above 750 k Ω . This is because of the maximum low input voltage of
10 0.8 V and input leakage current of 1 μ A at the Schmitt trigger gate 420.

The oscillator circuitry shown in Fig. 6 is very stable over the temperature range of -40°C to 105°C. The output of the touch switch circuitry drops at a rate of approximately 40mV/°C when temperature falls below 0°C. If application requires operation at low temperatures (-40°C), the following three methods may be used to increase the output of the
15 switch: increase the oscillator's regulated supply voltage, increase the resistance of resistor 416, and use a higher gain transistor 410. All of these methods would increase sensitivity at high temperatures. Another way to correct this problem is to use a thermistor to vary the regulated supply voltage as a function of temperature.

Since the input power is regulated down to 26 V DC, variation of power (24 V
20 AC \pm 10% or 29 V DC to 36 V DC) does not affect circuit operation. Table 3 below shows

the measured output voltage of the switch for various supply voltages.

TABLE 3

SUPPLY VOLTAGE	SWITCH OUTPUT
36VDC	4.96V
35VDC	4.96V
34VDC	4.95V
33VDC	4.95V
32VDC	4.94V
31VDC	4.93V
30VDC	4.93V
29VDC	4.92V

$$\text{PSRR} = 6 \text{ mV/V} = -45\text{dB}$$

In order to determine the effect of body capacitance on circuit operation, the circuit of Fig. 3 was used to simulate glass, water resistance, and body capacitance. The following two conditions were simulated and tested:

1 - The maximum body capacitance that does not cause crosswalk when:

Temperature = 105°C
Supply Voltage = 36VDC
Glass Capacitance = 2pF
Water Resistance = 330k to 1MΩ

2 - The minimum capacitance to turn on a switch when:

Temperature = 0°C
Supply Voltage = 29VDC

T370X

5

10

15

20

37

Glass Capacitance = 2pF

3 - Operation at room temperature.

Table 4 below shows the signal and noise voltages at the switch output for different values of body capacitance and contamination resistance.

TABLE 4

CONTAMINATION RESISTANCE	BODY CAPACITANCE				
	20pF	220pF	330pF	550pF	1230pF
330 kΩ	S: 5.1V N: 2.0V	S: 5.1V N: 4.0V	S: 5.1V N: 4.5V	S: 5.1V N: 4.9V	S: 5.1V N: 5.0V
500 kΩ	S: 5.1V N: 0.2V	S: 5.1V N: 0.6V	S: 5.1V N: 0.7V	S: 5.1V N: 0.8V	S: 5.1V N: 0.8V
1 MΩ (Condensed Water)	S: 5.1V N: 0.1V	S: 5.1V N: 0.1V	S: 5.1V N: 0.1V	S: 5.1V N: 0.1V	S: 5.1V N: 0.1V
NONE	S: 5.1V N: 10mV	S: 5.1V N: 10mV	S: 5.1V N: 10mV	S: 5.1V N: 10mV	S: 5.1V N: 10mV

S = Signal (TOUCH)
N = Noise (NO TOUCH)
supply voltage = 36VDC
temperature = 105°C

With contamination resistance of 1 MΩ or more, the circuit is insensitive to body capacitance variations and has a minimum signal-to-noise ratio of -34dB. With no contamination, signal-to-noise ratio is approximately -54dB. The graph in Fig. 9 shows the

signal-to-noise ratio versus body capacitance, for different values of contamination resistance at 105°C. The minimum body capacitance to turn on a switch is 20 pF.

At room temperature, crosstalk decreases because of gain drop of transistor 410.

Table 5 below shows that at room temperature, the circuit rejects 250 kΩ of contamination, independent of body capacitance. Below 250 kΩ, body capacitance will affect crosstalk.

TABLE 5

CONTAMINATION RESISTANCE	BODY CAPACITANCE				
	20pF	220pF	330pF	550pF	1230pF
200kΩ	S: 5.1V N: 0.2V	S: 5.1V N: 1.0V	S: 5.1V N: 1.2V	S: 5.1V N: 1.8V	S: 5.1V N: 2.2V
250kΩ	S: 5.1V N: 0.1V	S: 5.1V N: 0.1V	S: 5.1V N: 0.5V	S: 5.1V N: 0.5V	S: 5.1V N: 0.5V
330kΩ	S: 5.1V N: 0.1V	S: 5.1V N: 0.1V	S: 5.1V N: 0.1V	S: 5.1V N: 0.1V	S: 5.1V N: 0.1V
1MΩ (Condensed Water)	S: 5.1V N: 0.1V	S: 5.1V N: 0.1V	S: 5.1V N: 0.1V	S: 5.1V N: 0.1V	S: 5.1V N: 0.1V

S=Signal(TOUCH)
N=Noise(NO TOUCH)
supply voltage = 36VDC
temperature = 25°C

The graph of Fig. 10 shows the measured signal-to-noise ratio versus body capacitance, for different contamination resistance values at room temperature.

The particular advantages of the preceding circuit over that of existing touch

detection circuits such as that disclosed in U.S. Patent No. 4,758,735, are the use of diode 414 (selected for high speed) to minimize forward recovery time rather than merely provide reverse polarity protection (as with the slower type of diode used in the existing circuits) and the omission of a capacitor coupled across the base to emitter junction of the detection transistor 410

5 to make the circuit more sensitive and operable with a lower oscillator amplitude and higher oscillator frequency. These features along with appropriate choices in component values make possible operation at significantly higher frequencies (> 50 to 800 kHz) than are seen in existing art (60 to 1000 Hz). At frequencies at or near 800 kHz, the 20 - 300 pF of capacitance to ground offered by the human body presents a considerably lower impedance than the primarily resistive

10 impedance of skin oil or water films that may appear on the dielectric layer overlying the conductive touch pads. This allows the peak voltage of a pad that is touched to come considerably closer to ground than adjacent pads which will have a voltage drop across any contaminating film layer that is providing a conductive path to the area that is touched. The enhanced sensitivity offered by the omission of any capacitor between the base and emitter of

15 the detection transistor 410, allows the threshold of detection to be set much closer to ground than would be the case otherwise. This allows discrimination between the pad that is touched and adjacent pads that might be pulled towards ground via the conductive path to the touch formed by a contaminating film. This high frequency regime of operation offers a considerable advantage relative to the existing art in terms of immunity to surface contaminants such as skin

20 oil and moisture.

A multiple touch pad circuit constructed in accordance with the second embodiment is shown in Fig. 11. In the second embodiment of Fig. 11, components similar to those in the first embodiment in Fig. 4 are designated with the same references numerals and will not be discussed in detail. The multiple touch pad circuit is a variation of the first embodiment in that it includes an array of touch circuits designated as 900₁ through 900_{nm}, which, as shown, include both the touch circuit 400 shown in Figs. 4 and 8 and the input touch terminal pad 451 (Fig. 4). Microcontroller 500 selects each row of the touch circuits 900₁ to 900_{nm} by providing the signal from oscillator 200 to selected rows of touch circuits. In this manner, microcontroller 500 can sequentially activate the touch circuit rows and associate the received inputs from the columns of the array with the activated touch circuit(s). To keep the path length between the touch pad ⁴⁵¹~~451~~ and the base to the detection transistor 410 to a minimum, the detection circuits 900 are physically located directly beneath the touch pads. To simplify assembly, a flexible circuit board such as vended by Sheldahl, Inc. or Circuit Etching Technics, Inc. can be used for this purpose. Ideally, the printed circuit will be fixed directly against the surface (typically glass) bearing the conductive touch pads to eliminate air gaps and the need for conductive foam pads and spring contacts which were used to fill air gaps.

For this second embodiment, the oscillator 200 of the first embodiment may be slightly modified from that shown in Fig. 6 to include a transistor (not shown) coupled between the oscillator output and ground with it's base connected to microcontroller 600 such that microcontroller 600 may selectively disable the output of oscillator 200.

The use of a high frequency in accordance with the present invention provides distinct advantages for circuits such as the multiple touch pad circuit of the present invention due to the manner in which crosstalk is substantially reduced without requiring any physical structure to isolate the touch terminals. Further, the reduction in crosstalk afforded by the present invention, allows the touch terminals in the array to be more closely spaced together.

A third embodiment of the present invention, which provides touch circuit redundancy, is described below with reference to Figs. 12-14. As shown in Fig. 12, the switching circuit according to the third embodiment includes a voltage regulator 1100 for regulating power supplied by 24 V DC power lines 1101 and 1102 ^{with ground connection} ~~and an earth relative ground~~ 1103, ^a ~~and~~ for supplying the regulated power to an oscillator 1200 via lines 1104 and 1107.

Oscillator 1200 supplies a continuous and periodic signal to touch circuits 1400a and 1400b via line 1201. Preferably, the frequency of the oscillator output signal is at least 100 kHz, and more preferably, at least 800 kHz. The two touch circuits 1400a and 1400b are identical in construction and both receive the output of touch terminal 1450 via line 1451. A detailed description of the preferred voltage regulator circuit 1100, oscillator 1200, and touch circuits 1400a and 1400b is provided below with reference to Fig. 13 following the description of the remaining portion of the third embodiment.

The output of the first touch circuit 1400a is supplied to a first driver circuit 1500 via line 1401a while the output of the second touch circuit 1400b is supplied to a second driver circuit 1600 via line 1401b. The two driver circuits 1500 and 1600 are provided to drive first

and second serially connected switching transistors 1700 and 1710. The switching transistors 1700 and 1710 must both be conducting to supply power to a relay switch 1800. Thus, if one of touch circuits 1400a and 1400b does not detect a touch of touch terminal 1450, one of switching transistors 1700 and 1710 will not conduct and power will not be supplied to relay switch 1800. The preferred construction of driver circuits 1500 and 1600 and relay switch 1800 are described below with reference to Fig. 14.

As shown in Fig. 13, voltage regulator 1100 may be constructed by providing a first capacitor 1110 and a varistor 1112 connected in parallel across input power terminals 1101 and 1102. Preferably, return power terminal 1102 is connected ^{via line 1103 to ground} ~~to relative earth ground 1103~~. Varistor 1112 is used to protect the circuit for over-voltage conditions. Also connected in parallel with first capacitor 1110 and varistor 1112, are the serially connected combination of a fuse 1114, a diode 1116, a resistor 1118 and two parallel connected capacitors 1120 and 1122. The voltage regulator 1100 is reverse polarity protected by diode 1116 and current limited by resistor 1118. Capacitors 1120 and 1122 provide filtering.

Voltage regulator 1100 further includes a zener diode 1128 having its cathode connected to a node between resistor 1118 and capacitors 1120 and 1122 and to output power line 1104. The anode of zener diode 1128 is coupled to output ^{power common line} ~~power line 1107~~ and to ~~relative~~ ground line 1103 via two serially connected resistors 1124 and 1126. Zener diode 1128 and resistors 1124 and 1126 generate regulated 15 V DC. Two capacitors 1130 and 1132 are connected in parallel with zener diode 1128 between power lines 1104 and 1107. Capacitors

43

1130 and 1132 provide filtering and decoupling, respectively. Preferably, capacitor 1110 has a capacitance of 1000pF, 1000V, varistor 1112 is part no. S14K25 available from Siemens, fuse 1114 is a ¼A fuse, diode 1116 is part no. 1N4002 available from LITEON, resistor 1118 has a resistance of 10Ω, ½W, capacitor 1120 has a capacitance of 22μF, 35V, capacitor 1122 has a capacitance of 0.1μF, zener diode 1128 is part no. 1N4744A available from LITEON, resistor 1124 has a resistance of 220Ω, resistor 1126 has a resistance of 220Ω, capacitor 1130 has a capacitance of 1μF, 25V, and capacitor 1132 has a capacitance of 0.1μF.

Oscillator 1200 is preferably comprised of a first inverter gate 1210 having its input coupled to its output via resistors 1214 and 1216, and a second inverter gate 1212 having its input coupled to the output of first inverter gate 1210 and its output coupled to its input via a capacitor 1218 and resistor 1216. The oscillating output of the second inverter gate 1212 is buffered via transistor 1226, which has its base connected to the output of second inverter gate 1212 via resistor 1220 and capacitor 1222, which are connected in parallel therebetween. The base of transistor 1226 is also coupled to power line 1104 via a resistor 1224. The emitter of transistor 1226 is connected to power line 1104 and the collector is connected to power line 1107 via a resistor 1230, to the anode of a diode 1228, and to the oscillator output line 1201. Diode 1228 has its cathode connected to power line 1104 and is used to protect transistor 1226.

Preferably, inverter gates 1210 and 1212 are provided by part no. CD40106B available from Harris, resistor 1214 has a resistance of 10kΩ, resistor 1216 has a resistance of 1.18kΩ, 1%, capacitor 1218 has a capacitance of 220pF, resistor 1220 has a resistance of 4.7kΩ,

capacitor 1222 has a capacitance of 220pF, resistor 1224 has a resistance of 100kΩ, transistor 1226 is part no. MMBTA70L available from Motorola, diode 1228 is part no. RLS4448 available from LITEON, and resistor 1230 has a resistance of 3.3kΩ.

Two touch circuits 1400a and 1400b are provided in parallel to provide
5 redundancy so that if one fails, the relay drivers are disabled. Because the touch circuits 1400a and 1400b are identical, only one of the touch circuits will now be described. Touch circuit 1400a preferably includes two resistors 1410a and 1412a coupled in series between touch
a terminal output line 1451 and the base of a bipolar PNP transistor 1420a. Transistor 1420 has its emitter
a connected to the oscillator output line 1201 and its collector connected to power line 1107 via
10 a resistor 1422a. Touch circuit 1400a further includes a diode 1414a, a capacitor 1416a, and a resistor 1418a all connected in parallel between the base of transistor 1420a and the emitter thereof, which is connected to oscillator output line 1201. Touch circuit 1400a also includes a diode 1424a having its anode connected to the collector of transistor 1420a and its cathode connected to touch circuit output line 1401a via a resistor 1426a.

15 Preferably, resistor 1410a has a resistance of 5.1kΩ, resistor 1412a has a resistance of 5.1kΩ, diode 1414a is part no. RLS4448 available from LITEON, capacitor 1416a has a capacitance of 240pF, resistor 1418a has a resistance of 12MΩ, transistor 1420a is part
a no. BC857CL available from Motorola, resistor 1422a has a resistance of 100kΩ, diode 1424a
is part no. RLS4448 available from LITEON, and resistor 1426a has a resistance of 100kΩ.

20 The preferred detailed construction of the first and second driver circuits 1500 and

45

1600 will now be described with reference to Fig. 14. In first driver circuit 1500, the output
a line 1401a of first touch circuit 1400a is connected to power line 1107 via a resistor 1510 and
also via a capacitor 1512 connected in parallel therewith. The output line 1401a is also
a connected to the ~~negative~~ ^{inverting input} terminal of an operational amplifier 1514. The ~~positive~~ ^{non-inverting input} terminal of
5 operational amplifier 1514 is connected to line 1502, which runs between first and second driver
circuits 1500 and 1600 and is connected to power line 1104 via a resistor 1626. The output of
op amp 1514 is connected to power line 1104 via a resistor 1518 and to the input of a Schmitt
trigger inverter gate 1516. The output of Schmitt trigger inverter gate 1516 is connected to the
input of a second Schmitt trigger inverter gate 1526 via a resistor 1520. A diode 1522 is
10 connected in parallel with resistor 1520 with its cathode connected to the output of inverter gate
1516 and its anode connected to the input of inverter gate 1526 and to power line 1107 via
a capacitor 1524. The output of inverter gate 1526 is connected to the base of switching transistor
a 1700 via a resistor 1528. The base of transistor 1700 is also connected to power line 1107 via
a capacitor 1532 and to power line 1104 and its emitter via a resistor 1530.

15 Preferably, resistor 1510 has a resistance of $10M\Omega$, capacitor 1512 has a
capacitance of $0.01\mu F$, op amp comparator 1514 is part no. LM393 available from National
Semiconductor, inverter gate 1516 is part no. CD40106B available from Harris, resistor 1518
has a resistance of $10k\Omega$, resistor 1520 has a resistance of $1M\Omega$, diode 1522 is part no. RLS4448
available from LITEON, capacitor 1524 has a capacitance of $0.22\mu F$, inverter gate 1526 is part
20 no. CD40106 available from Harris, resistor 1528 has a resistance of $12k\Omega$, resistor 1530 has

a resistance of 100kΩ, capacitor 1532 has a capacitance of 0.01μF, and transistor 1700 is part no. MMBTA56L available from Motorola.

In second driver circuit 1600, the output line 1401b of second touch circuit 1400b

a is connected to power line 1107 via a resistor 1610 and also via a capacitor 1612 connected in
5 a parallel therewith. The output line 1401b is also connected to the ^{Common} ~~negative~~ ^{inverting input} terminal of an
a operational amplifier 1614. The ^{non-inverting input} ~~positive~~ terminal of operational amplifier 1614 is connected to
a line 1502, which is connected to power line 1104 via resistor 1626. The ^{non-inverting input} ~~positive~~ terminal of
a op amp 1614 is also connected to power line 1107 via a capacitor 1616 and a resistor 1618,
which are connected in parallel. The output of op amp 1614 is connected to power line 1104
10 a via a resistor ¹⁶³⁰ ~~1639~~ and to the coupled inputs of a Schmitt trigger inverter gate 1628. The output
a of op amp 1614 is also connected to its ^{non-inverting} ~~positive~~ input terminal via a resistor 1624. The output
a of Schmitt trigger inverter gate 1628 is connected to the input of a second Schmitt trigger
inverter gate 1638 via a resistor 1632. A diode 1634 is connected in parallel with resistor 1632
a with its cathode connected to the output of inverter gate 1628 and its anode connected to the
15 a input of inverter gate 1638 and to power line 1107 via a capacitor 1636. The output of inverter
a gate 1638 is connected to the base of switching transistor 1710 via a resistor 1640. The base
a of transistor 1710 is also connected to power line 1107 via a capacitor 1642 and to power line
1104 via a resistor 1644. Second driver circuit 1600 also preferably includes capacitors 1620
and 1622 connected in parallel between its connections to power lines 1104 and 1107.

20

Preferably, resistor 1610 has a resistance of 10MΩ, capacitor 1612 has a

capacitance of $0.01\mu\text{F}$, op amp comparator 1614 is part no. LM393 available from National Semiconductor, capacitor 1616 has a capacitance of $0.01\mu\text{F}$, resistor 1618 has a resistance of $20\text{k}\Omega$, capacitor 1620 has a capacitance of $0.1\mu\text{F}$, capacitor 1622 has a capacitance of $0.1\mu\text{F}$, resistor 1624 has a resistance of $100\text{k}\Omega$, resistor 1626 has a resistance of $10\text{k}\Omega$, inverter NAND gate 1628 is part no. CD4093B available from Harris, resistor 1630 has a resistance of $10\text{k}\Omega$, resistor 1632 has a resistance of $1\text{M}\Omega$, diode 1634 is part no. RLS4448 available from LITEON, capacitor 1636 has a capacitance of $0.22\mu\text{F}$, inverter NAND gate 1638 is part no. CD4093B available from Harris, resistor 1640 has a resistance of $12\text{k}\Omega$, capacitor 1642 has a capacitance of $0.01\mu\text{F}$, resistor 1644 has a resistance of $100\text{k}\Omega$, and transistor 1710 is part no. MMBTA56L available from Motorola.

In operation, the output of transistor 1420a (Fig. 13) taken at its collector is rectified by diode 1424a and a DC level is generated by resistors 1426a and 1510 and capacitor 1512 (a DC level of the output of transistor 1420b is generated by resistors 1426b and 1610 and capacitor 1612). When this DC level exceeds the upper threshold voltage of op amp comparator 1514 (1614), the output of schmitt triggered inverter gate 1516 ^{inverter NAND gate 1628} goes high which charges capacitor 1524 (1636) through resistor 1520 (1632). Gates 1516 and 1526 (1628 and 1638), resistor 1520 (1632), and capacitor 1524 ^b (1536) provide debounce in a conventional manner. Diode 1522 (1634) is used to provide fast release when ^{the} palm of the hand is removed from the ^{touch terminal} ~~button~~ 1450. The output of the debounce circuitry drives transistor 1700 (1710). Resistor 1528 (1640) and capacitor 1532 (1642) are used to filter noise. Both touch circuits must be functional

in order to drive the relay switch 1800. Also, if one of the transistors 1700 or 1710 fails, the relay will not be activated.

Relay switch 1800 may be any conventional relay. An example of such a relay is shown in Fig. 14. Relay switch 1800 may include a relay coil 1810 coupled between the selective power supply 1711 of transistors 1700 and 1710 and ground, and a pair of magnetically responsive switches that switch from normally closed terminals 1805 and 1807 to normally open terminals 1801 and 1803 when the relay coil is energized. A zener diode 1815 may be placed in series with a diode 1820 to reduce stress on the relay coil 1810 and to protect transistor 1710 when transistors 1700 and 1710 switch off.

Although the touch circuits of the third embodiment are disclosed as operating a relay switch via driver circuits, it will be appreciated by those skilled in the art that the outputs of touch circuits 1400a and 1400b could be supplied to a microcontroller in the manner discussed above with respect to the first embodiment.

The palm button switch of the present invention uses two redundant touch switch circuits, such as shown in Fig. 12, to disable relay drivers if one fails and redundant circuitry to turn off a relay switch if one fails.

of the touch switch circuits relay driver
of the driver circuits

Alternatively, the circuitry shown in Fig. 4 could be used. In another embodiment a method to prevent inadvertent actuations is to require a multi-step process. Referring to Fig. 19, a device is shown having a first palm button 2201, a second palm button 2202, and an indicator light ~~2201~~ *2205. Palm button 2201* has to be activated first and then button 2202 has to be

activated ~~second~~ within a 2 second time window before a desired actuation can occur. The 90 degree orientation of the two buttons makes it extremely difficult to accidentally touch both with an arm and an elbow or other such physical combination. An added advantage is that the motion required to move the hand from button 2201 to button 2202 can provide some relief from fatigue in the forearm by the resulting muscle flexure that would otherwise not occur if the hand had to be kept near a single button for extended periods of time. A further redundancy can be achieved by requiring simultaneous operation of two such devices, one for each hand. This provides further safeguards against inadvertent actuations and forces the operator to have both hands in a desired safe location once a desired actuation occurs. A further option is to provide one or more LEDs 2205 or audible annunciators for visual or audible feedback to the operator. Specifically, in Fig. 19 the LED 2205 will come on when button 2201 has been successfully activated to cue the operator that it is time to move to button 2202. Where required a second LED with a different color than the first (yellow for the first LED and red for the second) can be provided to provide visual confirmation that the second button 2202 has been activated or that the required combination of the two buttons has been activated. Two different audible tone or sound generators could also be used in lieu of the LEDs to provide feedback to the operator. In industrial or other challenging settings, the housing is made of high strength polycarbonate (or other high strength non-metallic material) to meet high impact and vibration requirements, preferably NEMA 4. A further option is to provide lighting for the switches to allow operation in the dark.

50

In a variation of the multi-step process, two touch plates within a housing (one vertical and one horizontal) are used to provide a two-step turn-on. Referring to Figs. 20A-C, the first step to actuate the output relay 2310, is initiated when the operator inserts his hands and touches the vertical touch sensor 2301 with the dorsal side of the hands. A yellow LED 2304 on top of the device show the successful completion of the first step. The second step is to flip the hand over and touch the horizontal touch sensor 2302 with the palmar side of the hand. A red LED 2305 on top of the device shows the completion of the two step turn-on and activation of output relay 2310. The flipping action of the hand in the second step causes the forearm muscles to flex, thereby reducing stiffness and fatigue. Also, the hands, and arms can rest on the run bar until the machine cycle is complete. The second step of the two-step turn-on must occur within some predetermined time (for example 2 seconds) after the release of vertical touch sensor or the first step must be repeated. In this proposed embodiment, the second step provides an added stimulus and reduces operator errors due to mental and physical fatigue. The top cover prevents actuation of two devices by the use of one hand and elbow of the same arm, as required by ANSI Standard B11.19-1990. The enclosure must be a high strength polycarbonate module to meet the high impact and vibration requirements of the industry, preferably NEMA 4. In both embodiments, high frequency switching is used to desensitize the unit against moisture and contaminants that could generate a path between the button and grounded chassis. The palm button may be formed as the flat palm button shown in Figs. 15A-C or as a dome-shaped palm button shown in Fig. 16. The button is made of a brass plate 1910 (1930) and can be covered

with a plastic or glass 1925 (1933) cover or membrane to desensitize the unit even more against contaminants and other inadvertent actuation. The plastic cover 1925 (1933) acts as a dielectric and capacitance is varied as a function of the area of the plastic being touched. Therefore, if button is touched by finger, a much smaller ^{series} capacitance is generated as opposed to button being touched by the palm of a hand. This capacitance is placed in series with the capacitance of the body ^{to ground} when the button is touched. Since the capacitance of the body is ^{to ground} much larger than the capacitance generated by the button, the functionality of the unit is independent of the variations in body capacitance ^{to ground} from person to person. The other factor that needs to be considered here is body resistance. If the button is not covered with an insulator such as plastic, the unit would become sensitive to body resistance. Body resistance to ^{ground} ~~earth~~, changes as a function of moisture in the work area, skin dryness, floor structure, and shoes. By using a plastic cover, the unit is made insensitive to variations of body resistance and capacitance. The shape of the button is also a factor in sensitivity. If the button is flat, less of the button area would be covered by the palm of the hand as opposed to a dome shape button that matches the contour of the palm. Therefore, if the button is dome-shaped, the unit can be even more desensitized against inadvertent operation.

By providing a large space for hand insertion and switch activation and a flat or dome shape button where the palm of the hand rests while machine cycle is in process, stress on the forearms is ergonomically reduced. The palm button of the present invention can be activated with or without gloves. The zero force palm button of the present invention may be

used to activate electric, pneumatic, air clutch, and hydraulic equipment such as punch presses, molding machines, etc.

As shown in Figs. 15A-C, the flat palm button may include a plastic housing 1917 having an optional metallic enclosure 1922 for surface mounting. The button also may include
5 a flush mount surface 1915 and optional guarding 1920.

The circuit board 1935 used with the palm button of the present invention may be packaged on two printed circuit boards. One board for power and relay and the other for touch switches and relay drivers. The touch circuit on the touch switch board is interfaced to the button through a screw that also holds the button in place. The power/relay board is
10 interfaced to the touch switch board through a three pin right angle connector. Wiring to the unit is done through a seven position terminal block on the power/relay board. The power/relay board is designed for 24 V DC input power and provides two double-throw relay contacts. However, it can be modified to accommodate different power inputs and switch outputs. For example, a transformer may be added to the power board so that the unit is powered
15 110VAC/220VAC instead of 24 V DC. Also, the relays may be replaced with other outputs such as digital or 4-20 mA outputs.

The touch circuit components can be integrated in a custom IC 2000, as shown in Fig. 17, to facilitate manufacturing and to reduce cost. Components 413, 412, 414, 410, 418, and 420 are similar to those of circuit 400 shown in Fig. 8. Preferably, resistor 2004 has a
20 resistance of 470k Ω and diode 2002 has characteristics similar to part no. 1N4148 available from

a LITEON. Resistors 2008 and 2006 are used to ^{adjust} ~~decrease and increase~~ the sensitivity,
a ~~respectively~~. Diode 2002 at the output of 420, allows the IC to be used in applications where
several touch circuit IC's are multiplexed.

5 a (Fig. 6) As shown in Fig. 18, a sleep circuit 2100 may be added to the oscillator circuit
200 to allow microcontroller 600 to turn off the oscillator circuit 200. The disabling of
oscillator circuit 200 is done to reduce drainage of capacitor 126 in the regulator circuit 120
during brown outs. The circuit diagram shown in Fig. 18 is a modified version of circuit 200
in Fig. 6. During normal operation microcontroller 600 pulls the input of gate 2116 to ground
and causes the output of gate 2116 to go high (power line 104). Therefore, transistor 2110 is
10 a biased on and oscillator 200 is functional. When in a sleep mode, microcontroller 600 ^{sources} ~~pulls~~ the
input to gate 2116 high and causes the output of gate 2116 to go low which turns off transistor
2110 and pulls the input of gate 212 low. Therefore, the oscillator will stop oscillating and
drainage on capacitor 126 decreases considerably.

15 The above described embodiments were chosen for purposes of describing but one
application of the present invention. It will be understood by those who practice the invention
and by those skilled in the art, that various modifications and improvements may be made to the
invention without departing from the spirit or scope of the invention as defined by the appended
claims.

CLAIMS

The embodiments of the invention in which an exclusive property or privilege is claimed are defined as follows.

Sub. 1
A3

1. A capacitive responsive electronic switching circuit comprising:
an oscillator providing a periodic output signal having a frequency of 50 kHz or greater;
an input touch terminal defining an area for an operator to provide an input by touch; and
a detector circuit coupled to said oscillator for receiving said periodic output signal from said oscillator, and coupled to said input touch terminal, said detector circuit being responsive to signals from said oscillator and the presence of an operator's body capacitance coupled to said touch terminal when touched by an operator to provide a control output signal.

2. The switching circuit as defined in claim 1, wherein said oscillator provides a periodic output signal having a frequency of 800 kHz or greater.

a

3. The switching circuit as defined in claim 1 and further including a DC power supply for supplying power to said oscillator and a ~~reference to an external~~ ground.

4. The switching circuit as defined in claim 1, wherein said periodic output signal provided by said oscillator is a square wave output signal, said oscillator includes a square wave generator for generating a square wave, and a plurality of active elements coupled to an output

55

of said square wave generator to buffer and improve the shape of the square wave output therefrom.

Sub 104

5. The switching circuit as defined in claim 1 and further including a floating ground generator coupled to said oscillator for receiving said square wave output signal, said floating ground generator generating a floating ground reference for said detector circuit that is set at a fixed voltage below and tracks the square wave output signal.

6. The switching circuit as defined in claim 5, wherein said detector circuit is powered by said square wave output signal provided by said oscillator and said floating ground reference provided by said floating ground generator to increase the sensitivity of said detector circuit to touching of said touch terminal by an operator's body.

~~7.~~ ^{11.} The switching circuit as defined in claim ~~6~~ ¹⁰, wherein said detector circuit includes a microcontroller and a charge pump circuit coupled between said input touch terminal and said microcontroller.

~~8.~~ ^{5.} The switching circuit as defined in claim 1, wherein said detector circuit includes a microcontroller and a charge pump circuit coupled between said input touch terminal and said microcontroller.

56

^{6.}
~~9.~~ The switching circuit as defined in claim 1, wherein said detector circuit includes a microcontroller and a touch circuit coupled between said input touch terminal and said microcontroller.

^{7.}
~~10.~~ The switching circuit as defined in claim ⁶~~9~~ and further including a plurality of said input touch terminals and a plurality of said touch circuits respectively associated with said input touch terminals.

^{8.}
~~11.~~ The switching circuit as defined in claim ⁷~~10~~, wherein said microcontroller selectively applies said periodic output signals received from said oscillator to each of said touch circuits to separately activate each touch circuit.

12. A touch controlled switching circuit comprising:
an oscillator providing a square wave output signal having a frequency of 50 kHz or greater;
a touch terminal defining an input terminal for coupling to an operator's body capacitance; and
a charge pump circuit coupled to said oscillator for receiving said square wave output signal, and coupled to said touch terminal, said charge pump circuit having an output terminal that supplies an output signal having a voltage that varies when said touch terminal is touched

amb.
CS

a

57

by an operator's body,

wherein said charge pump circuit includes at least one high speed diode coupled between said oscillator and said touch terminal, for enhancing a sensitivity at which said charge pump responds to sensed body capacitance at said touch terminal for higher frequencies.

Pub.
13
Cond.

13. The touch control circuit as defined in claim 12 and further including a DC power supply for supplying power to said oscillator and a reference to an external ground.

a

proximity and touch controlled

14. ~~The touch control~~ circuit as defined in claim 12, wherein said oscillator includes a square wave generator for generating a square wave, and a plurality of active elements coupled to an output of said square wave generator to buffer and improve the shape of the square wave output therefrom.

Pub.
16

15. The touch control circuit as defined in claim 12 and further including a floating ground generator coupled to said oscillator for receiving said square wave output signal, said floating ground generator generating a floating ground reference for said charge pump circuit that is set at a fixed voltage below and tracks said square wave output signal.

16. The touch control circuit as defined in claim 15, wherein said charge pump circuit is powered by said square wave output signal provided by said oscillator and said floating

58

Pub. 1
66
Orid.
a
ground reference provided by said floating ground generator to increase the sensitivity of said charge pump circuit to touching of said touch terminal by an operator's body.

15.

proximity and touch controlled
47. The touch control circuit as defined in claim 12, wherein said oscillator provides a periodic output signal having a frequency of 800 kHz or greater.

Pub. 1
67
5
18. A capacitive responsive electronic switching circuit comprising:

an oscillator providing a periodic output signal having a predefined frequency;

a plurality of input touch terminals defining adjacent areas on a dielectric substrate for an operator to provide inputs by touch; and

a detector circuit coupled to said oscillator for receiving said periodic output signal from said oscillator, and coupled to said input touch terminals, said detector circuit being responsive to signals from said oscillator and the presence of an operator's body capacitance coupled said touch terminals when touched by an operator to provide a control output signal,

10

wherein said predefined frequency of said oscillator is selected to decrease the impedance of said dielectric substrate relative to the impedance of any contaminate that may create an electrical on said dielectric substrate path between said adjacent areas.

19. The switching circuit as defined in claim 18, wherein said oscillator provides a

15

periodic output signal having a frequency of 800 kHz or greater.

20. A capacitive responsive electronic switching circuit comprising:
an oscillator providing a periodic output signal having a predefined frequency;
a dome-shaped touch terminal defining an area for an operator to provide an input by touch, wherein the dome shape of the touch terminal is constructed to ergonomically fit the palm of a human hand; and
a detector circuit coupled to said oscillator for receiving said periodic output signal from said oscillator, and coupled to said input touch terminals, said detector circuit being responsive to signals from said oscillator and the presence of an operator's body capacitance coupled said touch terminals when touched by an operator to provide a control output signal.

a

sub. 5
PS

10

add
AG

Dr. 601268

CAPACITIVE RESPONSIVE ELECTRONIC SWITCHING CIRCUIT

ABSTRACT OF THE DISCLOSURE

5

A capacitive responsive electronic switching circuit comprises an oscillator

providing a periodic output signal having a frequency of 50 kHz or greater, an input touch

a

terminal defining an area for an operator provide an input by touch, and a detector circuit ^{proximity and} coupled to the oscillator for receiving the periodic output signal from the oscillator, and coupled

10

to the input touch terminal. The detector circuit being responsive to signals from the oscillator

a

and the presence of an operator's body capacitance ^{to ground} coupled to the touch terminal ^{in proximity or} when touched by an operator to provide a control output signal. Preferably, the oscillator provides a periodic

output signal having a frequency of 800 kHz or greater. An array of touch terminals may be

provided in close proximity due to the reduction in crosstalk that may result from contaminants

15

by utilizing an oscillator outputting a signal having a frequency of 50 kHz or greater.

BAR CODE LABEL



U.S. PATENT APPLICATION

SERIAL NUMBER

08/601,268

FILING DATE

01/31/96

CLASS

307

GROUP ART UNIT

2107

APPLICANT

BYRON HOURMAND, HERSEY, MI.

CONTINUING DATA***
VERIFIED

FOREIGN/PCT APPLICATIONS***
VERIFIED

FOREIGN FILING LICENSE GRANTED 07/24/96

***** SMALL ENTITY *****

STATE OR COUNTRY

MI

SHEETS DRAWING

13

TOTAL CLAIMS

20

INDEPENDENT CLAIMS

4

FILING FEE RECEIVED

\$479.00

ATTORNEY DOCKET NO.

NAR01-P-310

ADDRESS

PRICE HENEVELD COOPER
DEWITT & LITTON
695 KENMOOR DRIVE SE
P O BOX 2567
GRAND RAPIDS MI 49501

TITLE

CAPACITIVE RESPONSIVE ELECTRONIC SWITCHING CIRCUIT

This is to certify that annexed hereto is a true copy from the records of the United States Patent and Trademark Office of the application which is identified above.

By authority of the
COMMISSIONER OF PATENTS AND TRADEMARKS

Date

Certifying Officer

PATENT APPLICATION FEE DETERMINATION RECORD
Effective October 1, 1995

Application or Docket Number

601268

CLAIMS AS FILED - PART I

(Column 1) (Column 2)

FOR	NUMBER FILED	NUMBER EXTRA
BASIC FEE		
TOTAL CLAIMS	20 minus 20 = *	
INDEPENDENT CLAIMS	4 minus 3 = *	1
MULTIPLE DEPENDENT CLAIM PRESENT		

* If the difference in column 1 is less than zero, enter "0" in column 2

SMALL ENTITY

OR

OTHER THAN SMALL ENTITY

RATE	FEE
	375.00
x\$11=	
x39=	39
+125=	
TOTAL	414

OR

OR

OR

OR

OR

RATE	FEE
	750.00
x\$22=	
x78=	28
+250=	
TOTAL	828

CLAIMS AS AMENDED - PART II

(Column 1) (Column 2) (Column 3)

AMENDMENT A		CLAIMS REMAINING AFTER AMENDMENT		HIGHEST NUMBER PREVIOUSLY PAID FOR	PRESENT EXTRA
	Total	*	32	Minus	** 20
Independent	*	8	Minus	*** 4	= 4
FIRST PRESENTATION OF MULTIPLE DEPENDENT CLAIM					

SMALL ENTITY

OR

OTHER THAN SMALL ENTITY

RATE	ADDITIONAL FEE
x\$11=	132
x39=	160
+125=	
TOTAL ADDIT. FEE	292

OR

OR

OR

OR

RATE	ADDITIONAL FEE
x\$22=	
x78=	
+250=	
TOTAL ADDIT. FEE	

(Column 1) (Column 2) (Column 3)

AMENDMENT B		CLAIMS REMAINING AFTER AMENDMENT		HIGHEST NUMBER PREVIOUSLY PAID FOR	PRESENT EXTRA
	Total	*		Minus	**
Independent	*		Minus	***	=
FIRST PRESENTATION OF MULTIPLE DEPENDENT CLAIM					

TOTAL ADDIT. FEE

TOTAL ADDIT. FEE

(Column 1) (Column 2) (Column 3)

AMENDMENT C		CLAIMS REMAINING AFTER AMENDMENT		HIGHEST NUMBER PREVIOUSLY PAID FOR	PRESENT EXTRA
	Total	*		Minus	**
Independent	*		Minus	***	=
FIRST PRESENTATION OF MULTIPLE DEPENDENT CLAIM					

TOTAL ADDIT. FEE

TOTAL ADDIT. FEE

RATE	ADDITIONAL FEE
x\$11=	
x39=	
+125=	
TOTAL ADDIT. FEE	

OR

OR

OR

OR

RATE	ADDITIONAL FEE
x\$22=	
x78=	
+250=	
TOTAL ADDIT. FEE	

* If the entry in column 1 is less than the entry in column 2, write "0" in column 3.
 ** If the "Highest Number Previously Paid For" IN THIS SPACE is less than 20, enter "20."
 *** If the "Highest Number Previously Paid For" IN THIS SPACE is less than 3, enter "3."
 The "Highest Number Previously Paid For" (Total or Independent) is the highest number found in the appropriate box in column 1.



08/601268

PATENT APPLICATION
Attorney Docket No. NAR01 P-310
Express Mail No. RB782578764US

#5
9-28-96
J. Was.

IN THE UNITED STATES PATENT AND TRADEMARK OFFICE

Applicant : Byron Hourmand
For : CAPACITIVE RESPONSIVE ELECTRONIC SWITCHING CIRCUIT

Box Patent Application
Hon. Commissioner of Patents and Trademarks
Washington, D.C. 20231

Dear Sir:

INFORMATION DISCLOSURE STATEMENT UNDER 37 C.F.R. § 1.97(b)

Pursuant to 37 C.F.R. §§ 1.56 and 1.97(b), Applicant brings to the attention of the Examiner the documents listed on the attached Form PTO-1449 (2 sheets). This Information Disclosure Statement is being filed within three months of the filing date of the above-referenced application.

Copies of the listed documents are submitted herewith along with Form PTO-1449 (2 sheets). Applicant respectfully requests that the Examiner consider the listed documents and evidence that consideration of relevant portions thereof by making appropriate notations on the attached form.

This submission does not represent that a search has been made or that no better art exists and does not constitute an admission that each or all of the listed documents are material or constitute "prior art." If it should be determined that any of the listed documents do not constitute "prior art" under United States law, Applicant reserves the right to present to the Office the relevant facts and law regarding the appropriate status of such documents.

Applicant further reserves the right to take appropriate action to establish the patentability of the disclosed invention over the listed documents, should one or more of the documents be applied against the claims of the present application.

If there is any fee due in connection with the filing of this Statement, please charge the fee to our Deposit Account No. 16-2463.

Respectfully submitted,

BYRON HOURMAND

By: Price, Heneveld, Cooper,
DeWitt & Litton

Terry S. Callaghan
Registration No. 34 559
695 Kenmoor, S.E.
P.O. Box 2567
Grand Rapids, MI 49501
(616) 949-9610

Dated: January 31, 1996

TSC/mam
NAR01 P-310

SCORE Placeholder Sheet for IFW Content

Application Number: **08601268**

Document Date: **01/31/1996**

The presence of this form in the IFW record indicates that the following document type was received in paper and is scanned and stored in the SCORE database.

- Drawings

Images of the original documents are scanned in gray scale or color and stored in SCORE. Bi-tonal images are also stored in IFW. Defects visible in both IFW and SCORE are indicative of defects in the original paper documents.

To access the documents in the SCORE database, refer to instructions developed by SIRA.

At the time of document entry (noted above):

- Examiners may access SCORE content via the eDAN interface.
- Other USPTO employees can bookmark the current SCORE URL (<http://es/ScoreAccessWeb/>).
- External customers may access SCORE content via the Public and Private PAIR interfaces.

Form Revision Date: December 8, 2006

307 116
 Class Subclass
 ISSUE CLASSIFICATION

5796183
 5796183

UTILITY SERIAL NUMBER 08/601268 PATENT DATE AUG 18 1998 1st PATENT NUMBER

SERIAL NUMBER 08/601,268 FILING DATE 01/31/96 CLASS 307 SUBCLASS 116.000 GROUP ART UNIT 2107 EXAMINER KAPLAN

APPLICANTS BYRON, HOURMAND; HERSEY, MI.

CONTINUING DATA***
 VERIFIED

FOREIGN/PCT APPLICATIONS***
 VERIFIED

FOREIGN FILING LICENSE GRANTED 07/24/96 ***** SMALL ENTITY *****

Foreign priority claimed 35 USC 119 conditions met Yes No AS FILED STATE OR COUNTRY MI SHEETS DRWGS. 13 TOTAL CLAIMS 20 INDEP. CLAIMS 4 FILING FEE RECEIVED \$479.00 ATTORNEY'S DOCKET NO. NAR01-P-31

PRICE HENEVELD COOPER
 DEWITT & LITTON
 695 KENMOOR DRIVE SE
 P O BOX 2567
 GRAND RAPIDS MI 49501

TITLE CAPACITIVE RESPONSIVE ELECTRONIC SWITCHING CIRCUIT

U.S. DEPT. OF COMM. / PAT. & TM - PTO-436L (Rev. 12-94)

PARTS OF APPLICATION FILED SEPARATELY		DAWKINS Applications Examiner	
NOTICE OF ALLOWANCE MAILED		CLAIMS ALLOWED	
10/27/97		Total Claims	Print Claim
Jonathan Kaplan Assistant Examiner		32	1
ISSUE FEE		DRAWING	
Amount Due	Date Paid	Sheets Drwg.	Figs. Drwg.
660.00	1-29-98	13	25
Label Area		Print Fig.	4
WILLIAM M. SHOOK, JR. SUPERVISORY PATENT EXAMINER ART UNIT 217 Primary Examiner		ISSUE BATCH NUMBER T51	
PREPARED FOR ISSUE 10/28-97			
WARNING: The information disclosed herein may be restricted. Unauthorized disclosure may be prohibited by the United States Code Title 35, Sections 122, 181 and 368. Possession outside the U.S. Patent & Trademark Office is restricted to authorized employees and contractors only.			

ISSUE FEE IN FILE

Form PTO-436A (Rev. 9/92)

(FACE)

SEARCHED

Class	Sub.	Date	Exmr.
357	112, 113 116, 125 139, 140 157	4/12	AK
361	181	4/12	AK
U. [unclear]	Search	4/21/12	AK

SEARCH NOTES

	Date	Exmr.

INTERFERENCE SEARCHED

Class	Sub.	Date	Exmr.
357	112, 113 116, 125 139, 140 157	4/21/12	AK
361	181	10/21/12	AK

(RIGHT OUTSIDE)

Staple Issue Slip Here

POSITION	ID NO.	DATE
CLASSIFIER	35	3-10-66
EXAMINER	45	7-25-66
TYPIST	74	1-21-67
VERIFIER		
CORPS CORR.		
SPEC. HAND	45	6-15-66
FILE MAINT.		
DRAFTING		

INDEX OF CLAIMS

Claim	Date
1	
2	
3	
4	
5	
6	
7	
8	
9	
10	
11	
12	
13	
14	
15	
16	
17	
18	
19	
20	
21	
22	
23	
24	
25	
26	
27	
28	
29	
30	
31	
32	
33	
34	
35	
36	
37	
38	
39	
40	
41	
42	
43	
44	
45	
46	
47	
48	
49	
50	

Claim	Date
51	
52	
53	
54	
55	
56	
57	
58	
59	
60	
61	
62	
63	
64	
65	
66	
67	
68	
69	
70	
71	
72	
73	
74	
75	
76	
77	
78	
79	
80	
81	
82	
83	
84	
85	
86	
87	
88	
89	
90	
91	
92	
93	
94	
95	
96	
97	
98	
99	
100	

SYMBOLS
 ✓ Rejected
 √ Allowed
 (Through numbers) Cancelled
 R Restricted
 M Non-elected
 I Interference
 A Appeal
 O Objected

(LEFT INSIDE)