



[54] SYSTEM AND METHOD FOR A MULTI-APPLICATION SMART CARD WHICH CAN FACILITATE A POST-ISSUANCE DOWNLOAD OF AN APPLICATION ONTO THE SMART CARD

[75] Inventors: Alfred Chan, Daly City; Marc B. Kekicheff, Palo Alto; Joel M. Weise, Burlingame; David C. Wentker, San Francisco, all of Calif.

[73] Assignee: Visa International Service Association, Foster City, Calif.

[21] Appl. No.: 09/046,993

[22] Filed: Mar. 24, 1998

Related U.S. Application Data

[60] Provisional application No. 60/061,763, Oct. 14, 1997, and provisional application No. 60/041,468, Mar. 24, 1997.

[51] Int. Cl.⁶ H04L 9/00; H04L 9/08; G07F 7/08

[52] U.S. Cl. 380/25; 380/9; 380/21; 380/23; 380/24; 380/29; 380/30; 380/49; 380/50; 235/379; 235/380

[58] Field of Search 380/4, 23, 24, 380/25, 49, 50, 59, 9, 21, 29, 30; 235/379, 380, 382; 379/93.01, 93.05, 93.06, 93.12

[56] References Cited

U.S. PATENT DOCUMENTS

Table with 4 columns: Patent No., Date, Inventor, and Patent No. (e.g., 4,742,215 5/1988 Daughters et al. 235/487)

FOREIGN PATENT DOCUMENTS

Table with 4 columns: Patent No., Date, Country, and Office (e.g., E 100227 11/1994 Austria .)

OTHER PUBLICATIONS

- EPO, International Search Report, Jul. 3, 1998, International Application No. PCT/US 98/05674. Carol Hovenga Fancher, "In Your Pocket Smart Cards", Feb. 1997, IEEE. Chaum et al., "Smart Card 2000: The Future of IC Cards", Oct. 19, 1987, Elsevier Science Publishers B.V. Steven Levy, "E-Money (That's What I Want)", Dec. 1994, Wired Magazine. Carol H. Fancher, "Smart Cards as Potential Applications Grow, Computers in the Wallet are Making Unobtrusive Inroads", Aug. 1996, Scientific American Website. Jerome Svigals, "Smart Cards The New Bank Cards", 1985, MacMillan Publishing Company. Roy Bright, "Smart Cards: Principles, Practice, Applications", 1988, Ellis Horwood Limited. Jerome Svigals, "Smart Cards The Ultimate Personal Computer", 1985, MacMillan Publishing Company. Hawkes et al., "Integrated Circuit Cards, Tags and Tokens", 1990, BSP Professional Books.

Hiro Shogase, "The Very Smart Card: A Plastic Packet Bank", Oct. 1988, IEEE Spectrum.

David Naccache, "Cryptographic Smart Cards", Jun. 3, 1996, IEEE Micro 1996 Website.

Zoreda et al., "Smart Cards", 1994, Artech House.

"Identification Card Systems—Inter-Sector Electronic Purse Part 1: Concepts and Structures", 1994, European Standard, prEN 1546.

"Identification Card Systems—Inter-Sector Electronic Purse Part 2: Security Architecture", 1994, European Standard, prEN XXXXX-2.

"Identification Card Systems—Inter-Sector Electronic Purse Part 3: Data Elements and Interchanges", 1994, European Prestandard, prEN 1546-3.

"Identification Card Systems—Inter-Sector Electronic Purse Part 4: Devices", 1994, European Prestandard, prEN 1546-4.

"Identification Cards—Integrated Circuit(s) Cards With Contacts Part 1: Physical Characteristics", 1987, International Standard, ISO 7816-1, First Edition.

"Identification Cards—Integrated Circuit(s) Cards With Contacts Part 2: Dimensions and Location of the Contacts", 1988, International Standard, ISO 7816-2, First Edition.

"Identification Cards—Integrated Circuit(s) Cards With Contacts Part 3: Electronic Signals and Transmission Protocols", International Standard, ISO/IEC 7816-3, First Edition.

"Identification Cards—Integrated Circuit(s) Cards With Contacts Part 4: Inter-Industry Commands for Interchange", International Standard, ISO/IEC 7816-4, First Edition.

"Identification Cards—Integrated Circuit(s) Cards With Contacts Part 5: Numbering System and Registration Procedure for Application Identifiers", 1993, International Standard, ISO/IEC DIS 7816-5.

"Identification Cards—Physical Characteristics", 1995, International Standard, ISO/IEC 7810, Second Edition.

"Identification Cards—Recording Technique—Part 1: Embossing", 1995, International Standard, ISO/IEC 7811-1, Second Edition.

(List continued on next page.)

Primary Examiner—Bernarr E. Gregory
Attorney, Agent, or Firm—Beyer & Weaver, LLP

[57] ABSTRACT

A system and method allow card issuers to securely add applications during the lifetime of the card after the card has already been issued (post issuance). Loading of an application and/or objects from an application server via a card acceptance device (and its supporting system infrastructure delivery mechanism) onto a card post issuance is performed in a secure and confidential manner. A smart card includes a card domain application that manages the card. Any number of security domain applications on the card provide security for loaded applications by managing keys; each application is associated with a security domain. Each of the card domain and security domains has a command interface for off-card communication, and an API for internal card use. The card life cycle includes the states of masked, initialized, load secured and blocked. An application life cycle includes the states of not available, loaded, installed, registered, personalized, activated and blocked. An application can block the card.

24 Claims, 15 Drawing Sheets

OTHER PUBLICATIONS

“Identification Cards—Recording Technique—Part 2: Magnetic Stripe”, 1995, International Standard, ISO/IEC 7811-2, Second Edition.

“Identification Cards—Recording Technique—Part 3: Location of Embossed Characters on ID-1 Cards”, 1995, International Standard, ISO/IEC 7811-4, Second Edition.

“Identification Cards—Recording Technique—Part 5: Location of Read-Write Magnetic Track—Track 3”, 1995, International Standard, ISO/IEC 7811-5, Second Edition.

“Identification Cards—Recording Technique—Part 6: Magnetic Stripe—High Coercivity”, 1996, International Standard, ISO/IEC 7811-6, First Edition.

“Identification Cards—Financial Transaction Cards”, 1990, International Standard, ISO/IEC 7813, Fourth Edition.

“Identification Cards—Financial Transaction Cards Amendment 1”, 1996, International Standard, ISO/IEC 7813, Fourth Edition.

“Identification Cards—Contactless Integrated Circuit(s) Cards—Part 1: Physical Characteristics”, 1992, International Standard, ISO/IEC 10536-1, First Edition.

“Identification Cards—Contactless Integrated Circuit(s) Cards—Part 2: Dimensions and Location of Coupling Areas”, 1995, International Standard, ISO/IEC 10536-2, First Edition.

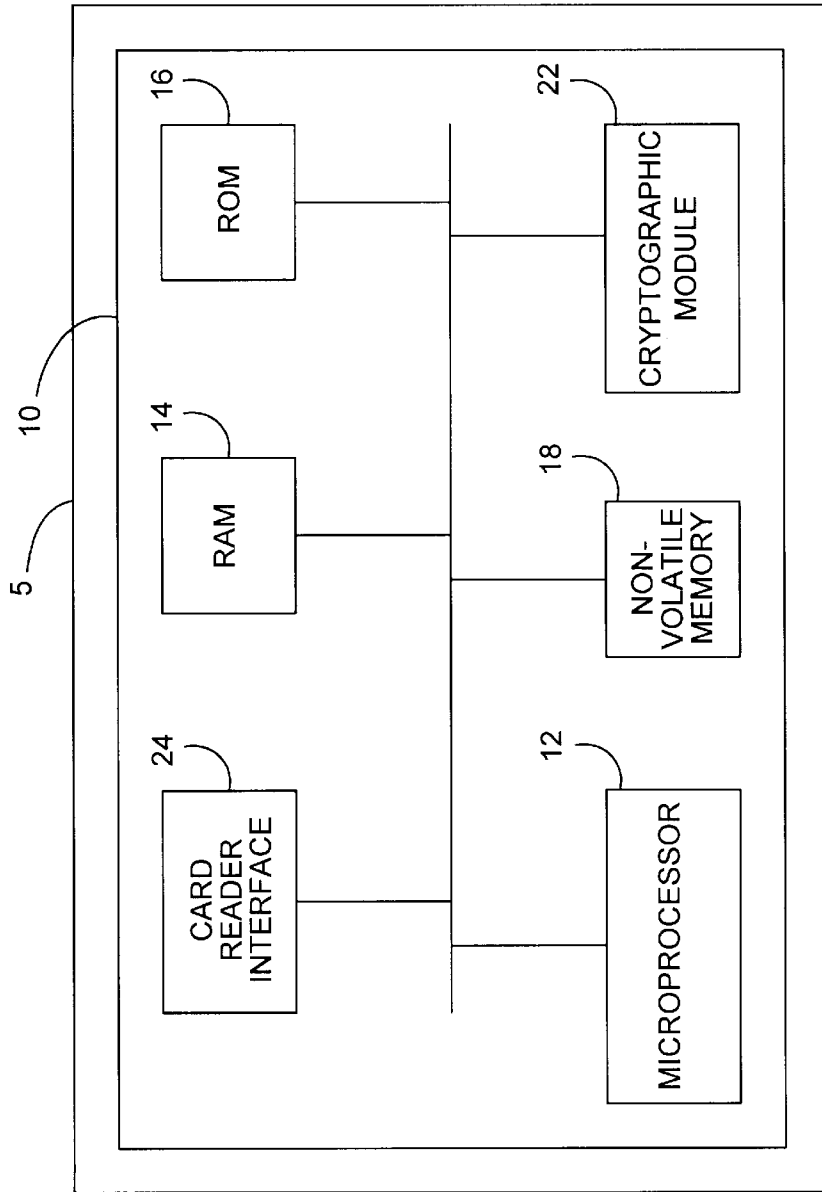

SMART CARD

FIG. 1
(PRIOR ART)

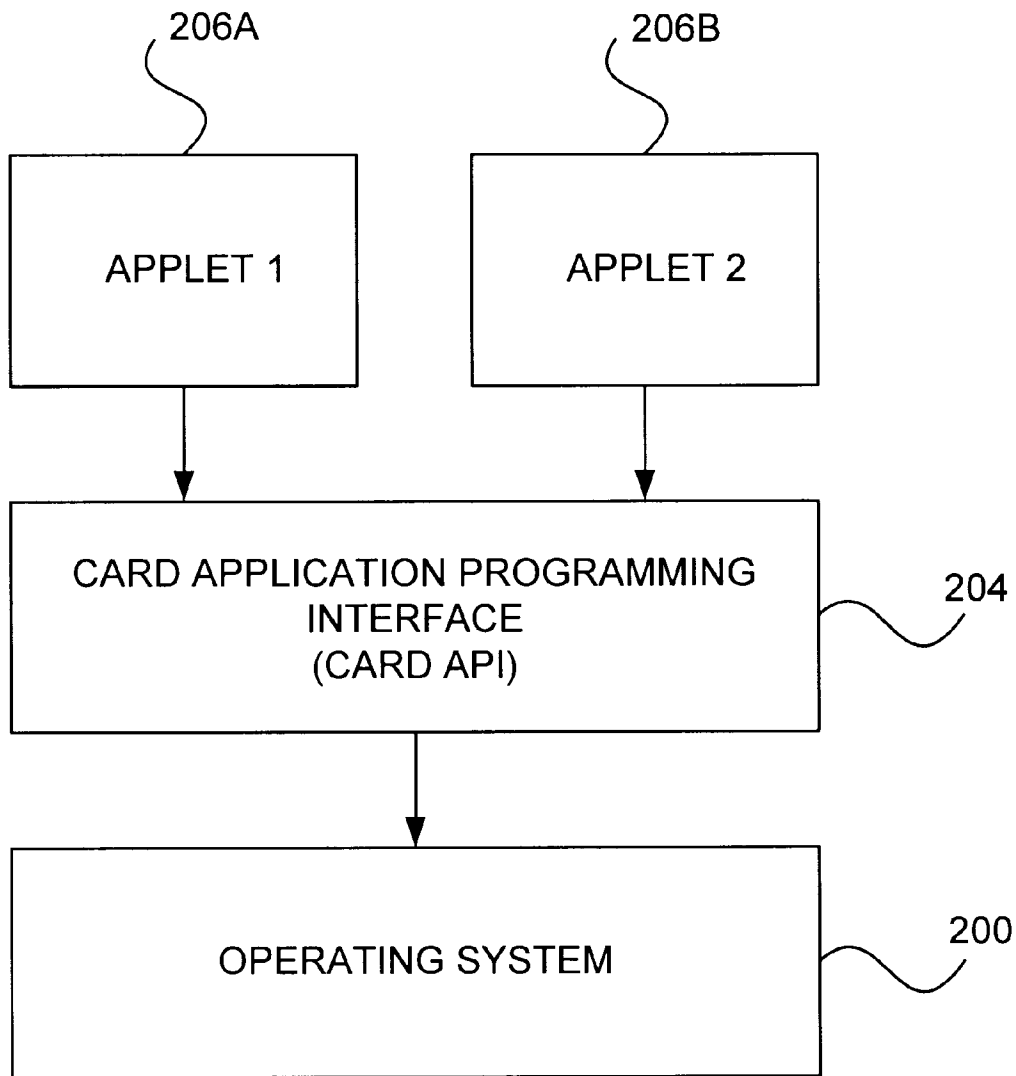

SMART CARD SOFTWARE LAYERS

FIG. 2
(PRIOR ART)

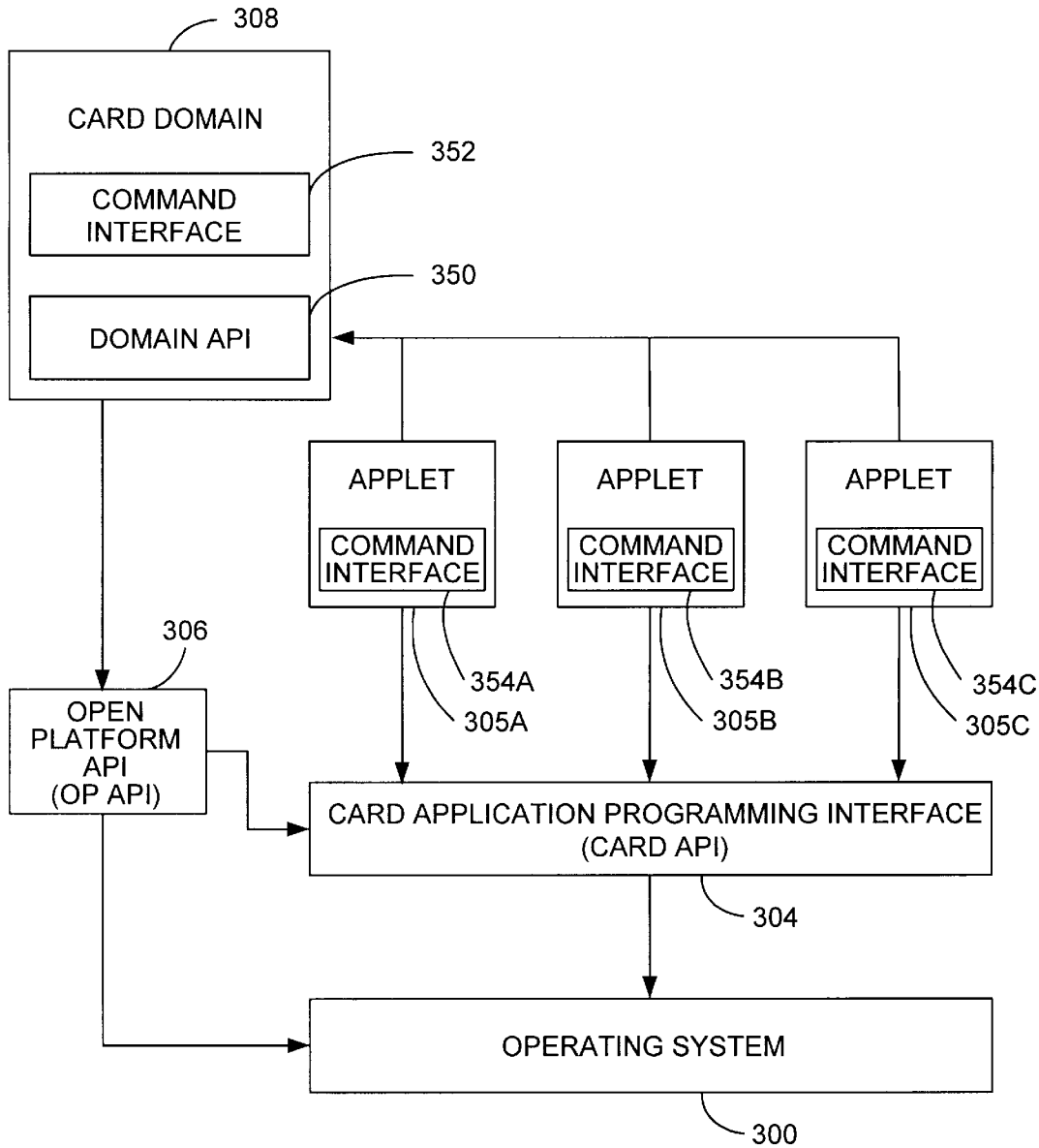

FIG. 3A

Explore Litigation Insights

Docket Alarm provides insights to develop a more informed litigation strategy and the peace of mind of knowing you're on top of things.

Real-Time Litigation Alerts



Keep your litigation team up-to-date with **real-time alerts** and advanced team management tools built for the enterprise, all while greatly reducing PACER spend.

Our comprehensive service means we can handle Federal, State, and Administrative courts across the country.

Advanced Docket Research



With over 230 million records, Docket Alarm's cloud-native docket research platform finds what other services can't. Coverage includes Federal, State, plus PTAB, TTAB, ITC and NLRB decisions, all in one place.

Identify arguments that have been successful in the past with full text, pinpoint searching. Link to case law cited within any court document via Fastcase.

Analytics At Your Fingertips



Learn what happened the last time a particular judge, opposing counsel or company faced cases similar to yours.

Advanced out-of-the-box PTAB and TTAB analytics are always at your fingertips.

API

Docket Alarm offers a powerful API (application programming interface) to developers that want to integrate case filings into their apps.

LAW FIRMS

Build custom dashboards for your attorneys and clients with live data direct from the court.

Automate many repetitive legal tasks like conflict checks, document management, and marketing.

FINANCIAL INSTITUTIONS

Litigation and bankruptcy checks for companies and debtors.

E-DISCOVERY AND LEGAL VENDORS

Sync your system to PACER to automate legal marketing.