



US006947748B2

(12) **United States Patent**
Li et al.

(10) **Patent No.:** **US 6,947,748 B2**
(45) **Date of Patent:** **Sep. 20, 2005**

(54) **OFDMA WITH ADAPTIVE SUBCARRIER-CLUSTER CONFIGURATION AND SELECTIVE LOADING**

(75) Inventors: **Xiaodong Li**, Bellevue, WA (US); **Hui Liu**, Sammamish, WA (US); **Kemin Li**, Bellevue, WA (US); **Wenzhong Zhang**, Bellevue, WA (US)

(73) Assignee: **Adaptix, Inc.**, Bothell, WA (US)

(*) Notice: Subject to any disclaimer, the term of this patent is extended or adjusted under 35 U.S.C. 154(b) by 765 days.

(21) Appl. No.: **09/738,086**

(22) Filed: **Dec. 15, 2000**

(65) **Prior Publication Data**

US 2002/0119781 A1 Aug. 29, 2002

(51) **Int. Cl.**⁷ **H04Q 7/20**; H04J 11/00

(52) **U.S. Cl.** **455/450**; 455/447; 455/453; 455/455; 455/464; 370/208

(58) **Field of Search** 455/447-453, 455/456.5, 456.6, 509, 512, 513, 524-526, 62, 63.1, 455, 463, 464, 168.1, 176.1, 179.1, 188.1, 550.1, 553; 370/311, 347, 480, 203-206, 208, 210, 329; 375/132

(56) **References Cited**

U.S. PATENT DOCUMENTS

5,280,630	A	1/1994	Wang	
5,479,447	A	12/1995	Chow et al.	
5,504,775	A	4/1996	Chouly et al.	
5,507,034	A *	4/1996	Bodin et al.	455/34.1
5,515,378	A	5/1996	Roy, III et al.	
5,555,268	A	9/1996	Fattouche et al.	
5,588,020	A	12/1996	Schilling	
5,708,973	A	1/1998	Ritter	
5,726,978	A *	3/1998	Frodigh et al.	370/252
5,734,967	A	3/1998	Kotzin et al.	
5,774,808	A *	6/1998	Sarkioja et al.	455/436
5,822,372	A	10/1998	Emami	

(Continued)

FOREIGN PATENT DOCUMENTS

DE	198 00 953 C1	7/1999	
DE	19800953 C1 *	7/1999 H04B/7/005
EP	0 869 647 A2	10/1998	
EP	0 926 912 A2	6/1999	
EP	0 929 202 A1	7/1999	
EP	0999658	5/2000	
FR	2 777 407 A1	10/1999	
GB	2 209 858 A	8/1997	
JP	06029922	2/1994	
WO	WO 98/16077 A2	4/1998	
WO	WO 98/30047 A1	7/1998	
WO	WO 02 49305 A2	6/2002	

OTHER PUBLICATIONS

Vittoria Mignone et al. "CD3-OFDM: A Novel Demodulation Scheme for Fixed and Mobile Receives," IEEE Transactions on Communications, Sep. 1996, vol. 44, No. 9.

Bender et al., CDMA/HDR: A Bandwidth-Efficient High-Speed Wireless Data Service for Nomadic Users, IEEE Communications Magazine, Jul. 2000, pp. 70-87.

(Continued)

Primary Examiner—William Trost

Assistant Examiner—Meless Zewdu

(74) *Attorney, Agent, or Firm*—Fulbright & Jaworski LLP

(57) **ABSTRACT**

A method and apparatus for subcarrier selection for systems is described. In one embodiment, the system employs orthogonal frequency division multiple access (OFDMA). In one embodiment, a method for subcarrier selection comprises each of multiple subscribers measuring channel and interference information for subcarriers based on pilot symbols received from a base station, at least one of subscribers selecting a set of candidate subcarriers, providing feedback information on the set of candidate subcarriers to the base station, and the one subscriber receiving an indication of subcarriers of the set of subcarriers selected by the base station for use by the one subscriber.

23 Claims, 7 Drawing Sheets

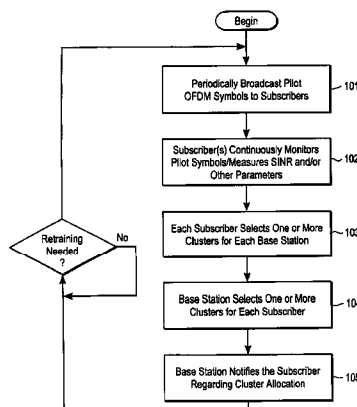

SPRINT 1117

U.S. PATENT DOCUMENTS

5,867,478	A	2/1999	Baum et al.	
5,886,988	A	3/1999	Yun et al.	
5,887,245	A	3/1999	Lindroth et al.	
5,909,436	A	6/1999	Engstrom et al.	
5,914,933	A	6/1999	Cimini et al.	
5,933,421	A	8/1999	Alamouti et al.	
5,956,642	A	9/1999	Larsson et al.	
5,973,642	A	10/1999	Li et al.	
5,991,273	A	11/1999	Abu-Dayya	
6,005,876	A	12/1999	Cimini, Jr. et al.	
6,009,553	A	12/1999	Martinez et al.	
6,026,123	A	2/2000	Williams	
6,041,237	A	3/2000	Farsakh	
6,052,594	A	4/2000	Chuang et al.	
6,061,568	A	5/2000	Dent	
6,064,692	A	5/2000	Chow	
6,064,694	A	5/2000	Clark et al.	
6,067,290	A	5/2000	Paulraj et al.	
6,108,374	A	8/2000	Balachandran et al.	
6,111,919	A	8/2000	Yonge, III	
6,131,016	A	10/2000	Greenstein et al.	
6,141,565	A	* 10/2000	Feuerstein et al.	455/560
6,144,696	A	11/2000	Shively et al.	
6,226,320	B1	5/2001	Hakkinen et al.	
6,298,092	B1	* 10/2001	Heath, Jr. et al.	375/267
6,307,851	B1	10/2001	Jung et al.	
6,327,472	B1	* 12/2001	Westroos et al.	455/450
6,330,460	B1	* 12/2001	Wong et al.	455/562
6,366,195	B1	4/2002	Harel et al.	
6,377,632	B1	4/2002	Paulraj et al.	
6,377,636	B1	* 4/2002	Paulraj et al.	375/346
6,449,246	B1	9/2002	Barton et al.	
6,473,467	B1	10/2002	Wallace et al.	
6,477,158	B1	11/2002	Take	
6,545,997	B1	4/2003	Bohnke et al.	
6,657,949	B1	12/2003	Jones, IV et al.	
2003/0067890	A1	4/2003	Goel et al.	
2003/0169681	A1	9/2003	Li et al.	
2003/0169824	A1	9/2003	Chayat	

OTHER PUBLICATIONS

Frullone et al., PRMA Performance in Cellular Environments with Self-Adaptive Channel Allocation Strategies, IEEE Transactions on Vehicular Technology, Nov. 1996, pp. 657-665 vol. 45, No. 4.

Xu, Guanghan and Li, San-Qi, Throughput Multiplication of Wireless Lans for Multimedia Services: SDMA Protocol Design, 1994 IEEE, pp. 1326-1332.

Ward, James and Compton, R. Ted, Jr., High Throughput Slotted ALOHA Packet Radio Networks with Adaptive Arrays, IEEE Transactions on Communications, Mar. 1993, pp. 460-470, vol. 41, No. 3.

Tsoulos, G.V., Smart antennas for mobile communication systems: benefits and challenges, Electronics & Communication Engineering Journal, Apr. 1999, pp. 84-94.

Shad et al., Indoor SDMA Capacity Using a Smart Antenna Basestation, 1997 IEEE, pp. 868-872.

Farsakh, Christof and Nosseck, Josef A., On the Mobile Radio Capacity Increase Through SDMA, no date (after 1997).

Bender, et al. "CDMA/HDR: A Bandwidth Efficient High-Speed Wireless Data Service for Nomadic Users," IEEE Communications Magazine, Jul. 2000, pp. 70-87.

Frullone, et al., "PRMA Performance in Cellular Environments with Self-Adaptive Channel Allocation Strategies," IEEE Transactions on Vehicular Technology, vol. 45, No. 4, Nov. 1996, pp. 657-665.

Farsakh, C. et al., "Maximizing the SDMA Mobile Radio Capacity Increase by DOA Sensitive Channel Allocation", Wireless Personal Communications, Kluwer Academic Publishers, NL, vol. 11, No. 1, Oct. 1999, pp. 63-76, XP000835062, ISSN: 0929-6212.

Wong, C.Y., et al., *Multiuser OFDM With Adaptive Subcarrier, Bit, and Power Allocation*, IEEE Journal on Selected Areas in Communications, Oct. 1999, IEEE Inc., New York, USA, vol. 17, Nr. 10, pp. 1747-1758, XP000854075, ISSN: 0733-8716 Sections I and II abstract.

Gruenheid, R. et al: "Adaptive Modulation and Multiple Access for the OFDM Transmission Technique", Wireless Personal Communications, Kluwer Academic Publishers, NL, vol. 13, NR. 1/2, Year 2000, pp. 5-13 XP000894156, ISSN: 0929-6212.

Motegi, M. et al.: "Optimum Band Allocation According to Subband Condition for BST-OFDM" 11th IEEE International Symposium on Personal Indoor and Mobile Radio Communications, vol. 2, Sep. 18-21, 2000, pp. 1236-1240, XP002213669, Piscataway, NJ, USA, ISBN: 0-7803-6463-5.

Kapoor, S. et al.: "Adaptive Interference Suppression in Multiuser Wireless OFDM Systems Using Antenna Arrays" IEEE Transactions on Signal Processing, vol. 47, No. 12, Dec. 1999, pp. 3381-3391, XP000935422, IEEE, New York, USA, ISSN: 1053-587X.

Ye Li, et al.: "Clustered OFDM with channel estimation for high rate wireless data", Mobile Multimedia Communications, 1999. (MOMUC '99). 1999 IEEE International Workshop on San Diego, CA, USA, IEEE, US, Nov. 15, 1999, pp. 43-50, XP010370695, ISBN: 0-7803-5904-6.

Nogueroles, R. et al.: "Improved Performance of a Random OFDMA Mobile Communication System" Vehicular Technology Conference, 1998. VTC 98. 48th IEEE Ottawa, Ontario, Canada, May 18-21, 1998, pp. 2502-2506, XP010288120, ISBN: 0-7803-4320-4.

Kinugawa, Y. et al.: "Frequency and Time Division Multiple Access with Demand-Assignment Using Multicarrier Modulation for Indoor Wireless Communications Systems", IEICE Transactions on Communications, Institute of Electronics Information and Comm. Eng. Tokyo, Japan, vol. E77-B, NR. 3, Mar. 1994, pp. 396-402, XP000451014, ISSN: 0916-8516.

* cited by examiner

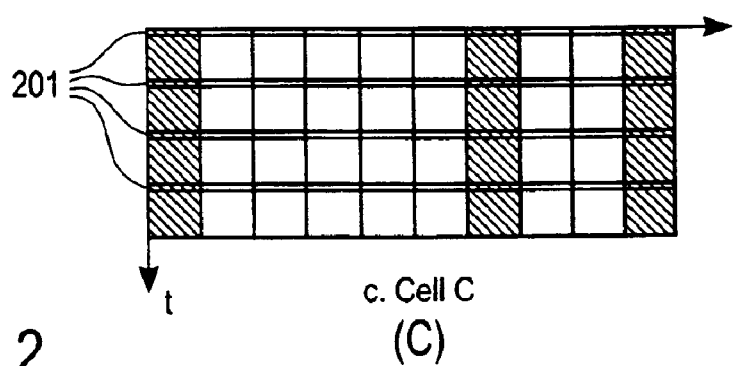
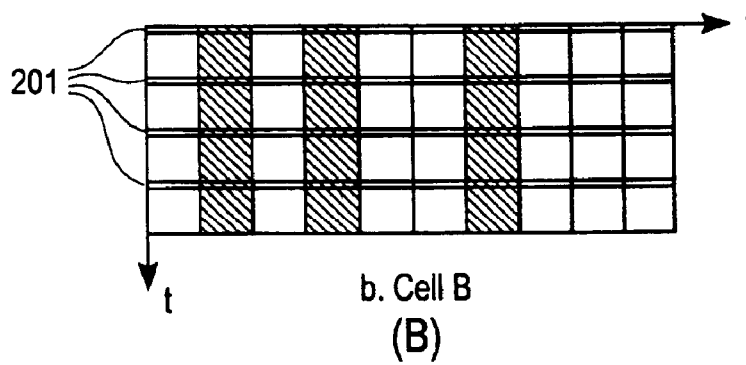
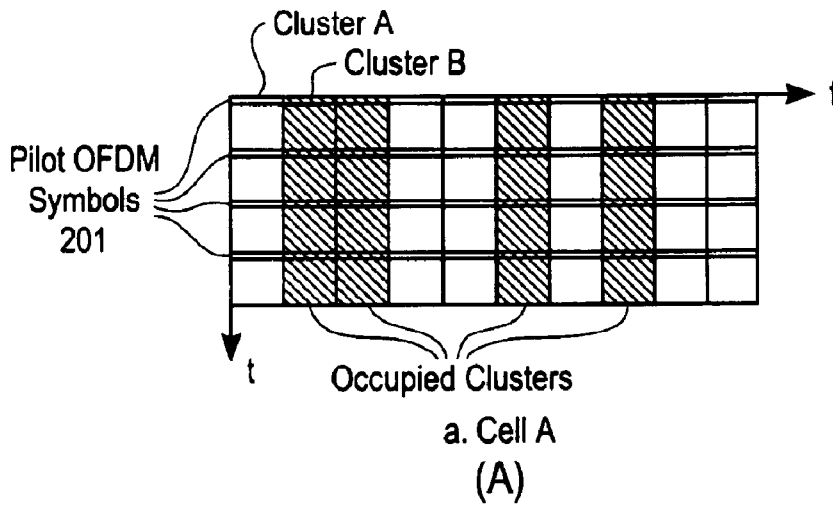
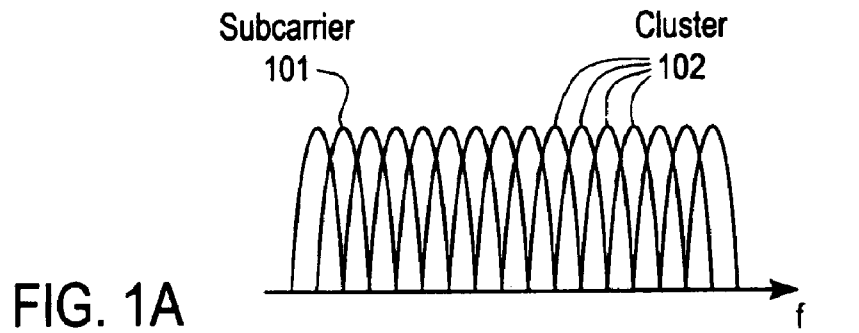

FIG. 2

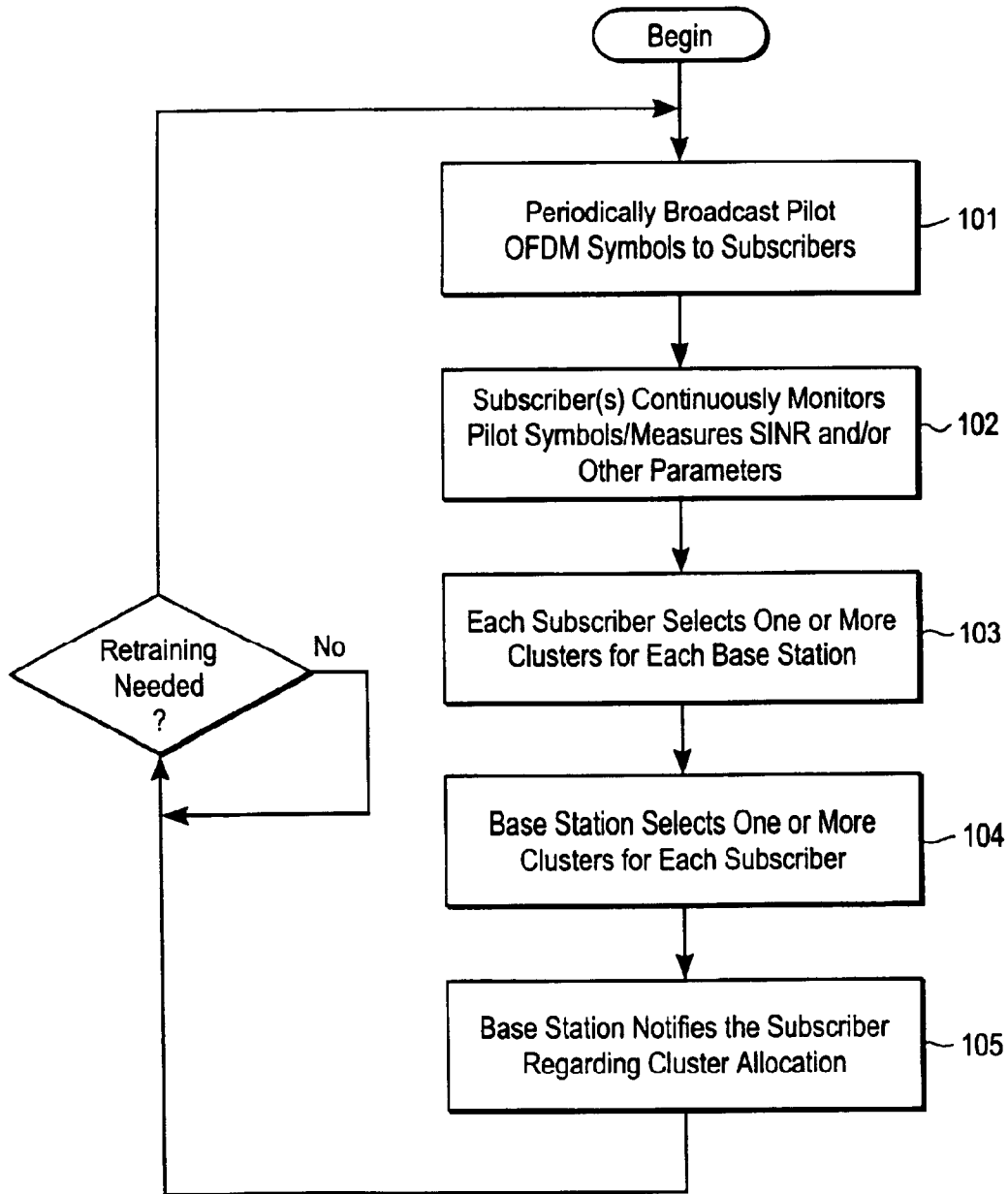

FIG. 1B

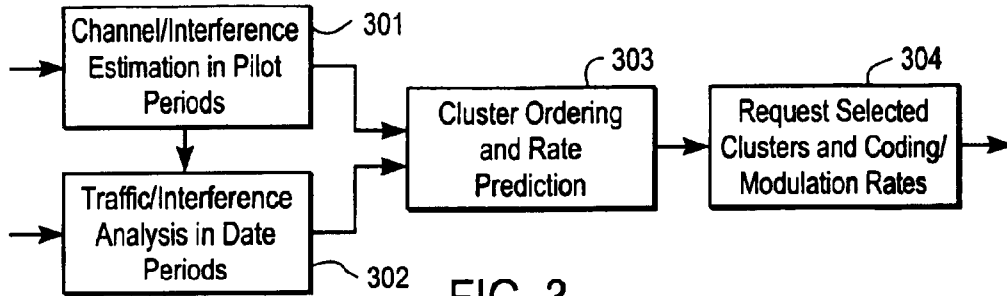

FIG. 3

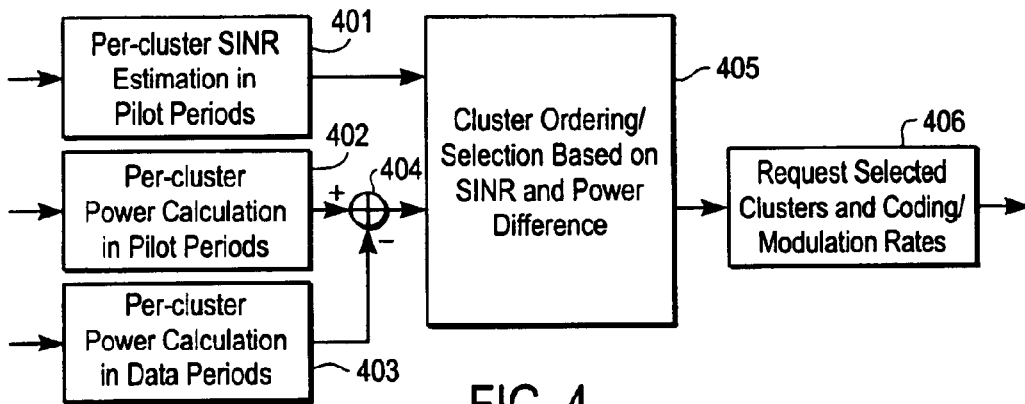

FIG. 4

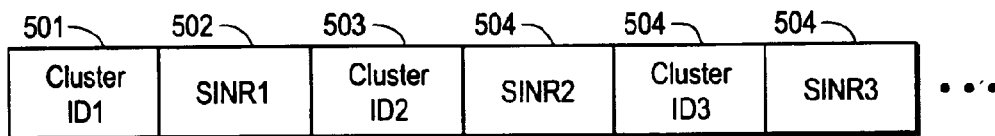

FIG. 5

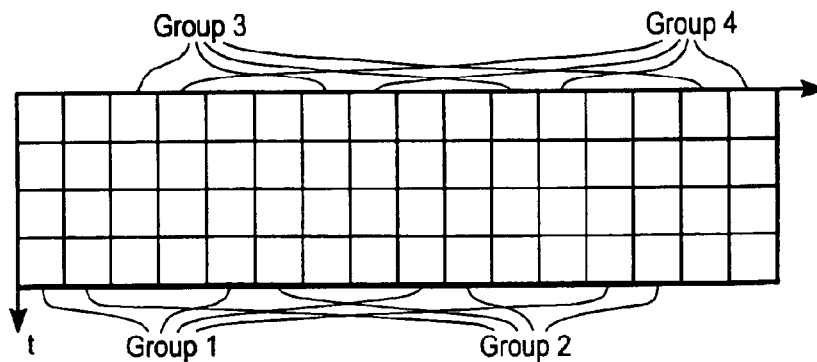

FIG. 6

Explore Litigation Insights

Docket Alarm provides insights to develop a more informed litigation strategy and the peace of mind of knowing you're on top of things.

Real-Time Litigation Alerts



Keep your litigation team up-to-date with **real-time alerts** and advanced team management tools built for the enterprise, all while greatly reducing PACER spend.

Our comprehensive service means we can handle Federal, State, and Administrative courts across the country.

Advanced Docket Research



With over 230 million records, Docket Alarm's cloud-native docket research platform finds what other services can't. Coverage includes Federal, State, plus PTAB, TTAB, ITC and NLRB decisions, all in one place.

Identify arguments that have been successful in the past with full text, pinpoint searching. Link to case law cited within any court document via Fastcase.

Analytics At Your Fingertips



Learn what happened the last time a particular judge, opposing counsel or company faced cases similar to yours.

Advanced out-of-the-box PTAB and TTAB analytics are always at your fingertips.

API

Docket Alarm offers a powerful API (application programming interface) to developers that want to integrate case filings into their apps.

LAW FIRMS

Build custom dashboards for your attorneys and clients with live data direct from the court.

Automate many repetitive legal tasks like conflict checks, document management, and marketing.

FINANCIAL INSTITUTIONS

Litigation and bankruptcy checks for companies and debtors.

E-DISCOVERY AND LEGAL VENDORS

Sync your system to PACER to automate legal marketing.