

ADAPTIVE CHANNEL ALLOCATION IN A FREQUENCY DIVISION MULTIPLEXED SYSTEM

Publication number: WO9701256
Publication date: 1997-01-09
Inventor: FRODIGH CARL MAGNUS; GUDMUNDSON PEROLS LEIF MIKAEL
Applicant: ERICSSON TELEFON AB L M (SE)
Classification:
 - international: H04J11/00; H04L5/02; H04L27/26; H04Q7/36; H04Q7/38; H04J11/00; H04L5/02; H04L27/26; H04Q7/36; H04Q7/38; (IPC1-7): H04Q7/38; H04L5/06
 - European: H04L5/02Q; H04L27/26M1P; H04Q7/38C4; H04W8/026
Application number: WO1996SE00814 19960620
Priority number(s): US19950493489 19950622

Also published as:

- EP0882377 (A1)
- US5726978 (A1)
- FI974555 (A)
- EP0882377 (A0)
- EP0882377 (B1)

more >>

Cited documents:

- WO9510144
- US5295138
- US5400322
- EP0637181
- EP0490509

more >>

Report a data error here

Abstract of WO9701256

A method and system of adaptive channel allocation in a frequency division multiplexed system is provided. In the method and system, a subset of M subcarriers is chosen from a larger set of N subcarriers available for communications on a link. As communications take place on the link, signal quality (C/I) measurements (342) on the subcarriers of the subset of M subcarriers and interference (I) measurements (344) on the subcarriers of the group of N subcarriers are periodically performed. The C/I and I measurements are then used to reconfigure (422) the subset of M subcarriers to reduce co-channel interference on the link.

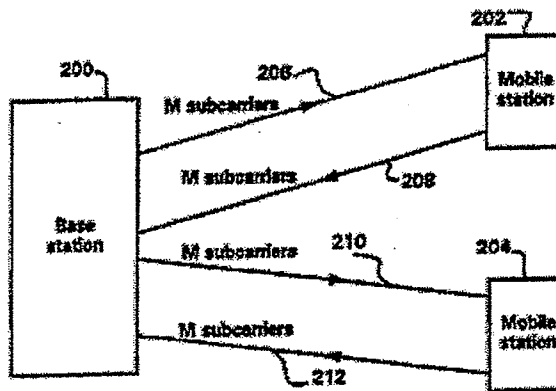

Data supplied from the esp@cenet database - Worldwide

SPRINT 1108
PART 2 OF 2

PATENT ABSTRACTS OF JAPAN

Ref. 2

(11)Publication number : 07-322219
 (43)Date of publication of application : 08.12.1995

(51)Int.Cl.

H04N 7/015
 H04N 7/20

(21)Application number : 06-079432

(71)Applicant : MATSUSHITA ELECTRIC IND CO LTD

(22)Date of filing : 25.03.1994

(72)Inventor : OSHIMA MITSUAKI

(30)Priority

Priority number : 05 66461	Priority date : 25.03.1993	Priority country : JP
05132984	10.05.1993	JP
05261612	24.09.1993	JP
05349972	27.12.1993	JP

(54) TRANSMITTER

(57)Abstract:

PURPOSE: To form the transmission/reception system in which much more information at the same frequency band is sent by solving it that the impossibility of transmission information quantity cannot be increased when a frequency band is limited in the transmitter sending a digital signal.

CONSTITUTION: A modulator 4 implementing m-value QAM modulation in a transmitter 1 assigns n-value data of a 1st data string to a signal point group formed by grouping signal points of n-value 1st data string and p-value 2nd and 3rd data strings on a space diagram and sends a modified m-value QAM modulation signal. A demodulator 25 of a 1st receiver 23 demodulates the n-value 1st data string, a 2nd receiver 33 demodulates the 1st and 2nd data strings, a 3rd receiver 43 demodulates the 1st, 2nd and 3rd data strings, and even in the case of the receiver having only n-value demodulation capability of $n < m$ demodulates data of the n-value 1st data string when the m-value modified multi-value modulation wave is received in the transmitter.

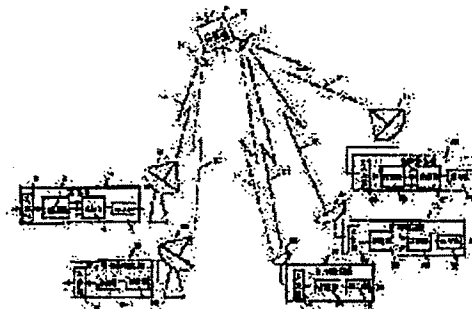

Partial English translation of Ref. 2:

----- (not translated) -----

[0334] As illustrated in a communication capacity traffic distribution chart of a conventional system in Fig. 117, in a conventional digital communication system such as QPSK, the transmission capacity at A ch of reception cells 768 and 770 is data 774 d which is a combination of data 774d and 774b of uniform frequency use efficiency of 2 bit/Hz shown in a chart of $d = A$ and data 774c in a chart of $d = B$, and the frequency use efficiency is uniform at 2 bit/Hz at any sites. Meanwhile, in an actual urban area, population density is high in areas where buildings are tightly packed as densely built-up areas 775a, 775b and 775c, and communication traffic volumes in these areas show peaks as shown in data 774e. The communication volume is small in areas surrounding the densely built-up areas. With respect to the data 774e of actual traffic volume TF, the capacity of conventional cellular phone is the same frequency efficiency of 2 bit/Hz in all areas as shown in the data 774d. That is, there is a problem of poor efficiency that the same frequency efficiency as that used in areas where the traffic volume is large is also used in areas where the traffic volume is small. The conventional system has dealt with the problem by allocating more frequencies to the areas where the traffic volume is large to increase the number of channels or reducing the size of the reception cell. However, the increase in the number of channels has a limitation of frequency spectrum. Further, multi-valuing such as 16QAM or 64QAM in the conventional system increases transmission power. Reducing the size of the reception cell and increasing the number of the cells cause an increase in the number of base stations and an increase in installation costs. The conventional system has the above problems.

[0335] Ideally, high frequency efficiency is used in areas where the traffic volume is large, high frequency efficiency is used in areas where the traffic volume is small, and low frequency efficiency is used in areas where the traffic volume is small, to increase the efficiency of the whole system. The above can be achieved by employing the hierarchical transmission system of the present invention. This will be described by use of a communication capacity traffic distribution chart in Example 8 of the present invention in Fig. 118. The distribution chart of Fig. 118 illustrates, from the top to the bottom, the communication capacities on the line A-A' of reception cells 770B, 768, 769, 770 and 770a. The reception cells 768 and 770 use frequencies of channels A, and the reception cells 770b, 769 and 770a use frequencies of channels B which are

not the same as those of the channels A. The numbers of these channels are increased or decreased by the base station controller 774 shown in Fig. 116 according to the traffic volume of each reception cell. In Fig. 118, $d = A$ illustrates the distribution of the communication capacity of the channel A, $d = B$ illustrates the communication capacity of the channel B, $d = A + B$ illustrates the total of the communication capacities of all channels, TF illustrates a communication traffic volume, and P illustrates distribution of buildings and populations. Since the reception cells 768, 769 and 770 use the multilayered transmission system such as SRQAM described in the above Example, 6 bit/Hz which is three times the frequency use efficiency 2 bit/Hz of QPSK is obtained around the base station as shown in data 776a, 776b and 776c. As the distance from the base station increases, the frequency use efficiency decreases to 4 bit/Hz and then to 2 bit/Hz. Although the areas of 2 bit/Hz become narrow as compared with the size of the reception cells of QPSK represented by dotted lines 777a, b and c without an increase in transmission power, the comparable size of the reception cells can be obtained by slightly increasing the transmission power of the base station. A mobile unit supporting 64SRQAM transmits or receives by modified QPSK resulting from setting the shift amount of SRQAM to $S = 1$ when it is distant from the base station, transmits or receives by 16SRQAM when close to the base station, and transmits or receives by 64SRQAM when closer to the base station. Therefore, the maximum transmission power never increases as compared with QPSK. Further, a transceiver of 4SRQAM having a simplified circuit as shown in a block diagram in Fig. 121 can communicate with other telephone while maintaining compatibility. The same applies to a unit of 16SRQAM shown in a block diagram in Fig. 122. Thus, mobile units of three modulation systems exist. In the case of a cellular phone, smallness in size and weight is important. In the case of 4SRQAM, although calling rate becomes higher since frequency use efficiency lowers, it is suited for users who desire smallness in the size and weight of cellular phone since the circuit is simplified. Thus, the present system can adapt to a wide variety of applications.

[0336] Thus, a transmission system having a distribution of different capacities as $d = A + B$ in Fig. 118 is obtained. Placing a base station according to the traffic volume of TF has a great effect that overall frequency use efficiency is improved. In particular, since a micro-cell system involving small cells allows many subbase stations to be installed, the subbase stations can be easily installed in areas with a large traffic volume, so that the effect of the present invention is significant.

FREQUENCY DIVISION MULTIPLEXING SYSTEM AND METHOD HAVING OPERATING PARAMETER CAPABLE OF DYNAMIC INCREASE AND DECREASE CONTROL

Publication number: JP10303849
 Publication date: 1998-11-13
 Inventor: VAN NEE RICHARD D J
 Applicant: LUCENT TECHNOLOGIES INC
 Classification:
 - international: H04J11/00; H04L27/26; H04L1/00; H04J11/00; H04L27/26; H04L1/00; (IPC1-7): H04J11/00
 - European: H04L27/26M2; H04L27/26M1; H04L27/26M1P
 Application number: JP19980088735 19980401
 Priority number(s): US19970834684 19970401

Also published as:

 EP0869647 (A2)
 US6175550 (B1)
 EP0869647 (A3)
 EP0869647 (B1)

Report a data error here

Abstract of JP10303849

PROBLEM TO BE SOLVED: To provide a flexible OFDM(orthogonal frequency division multiplexing) system which can provide the OFDM advantages to various types of communication environments by adding the increase/decrease control (scaling) to the OFDM system about its operating parameter or characteristic and accordingly improving the flexibility and adaptability of the OFDM system.
SOLUTION: A dynamic rate control circuit 15 responds to the optional one of conceivable inputs in order to set a coding block 14 at an appropriate coding rate. In an execution example of a transceiver, for example, the circuit 15 detects a transmission error through the feedback caused from a receiver and dynamically reduces the coding rate. In the same way, the circuit 15 controls the number of bits per symbol for each carrier wave to respond to various inputs. In such a constitution, an OFD system can work in various communication environments where various operating parameters or characteristics are required.

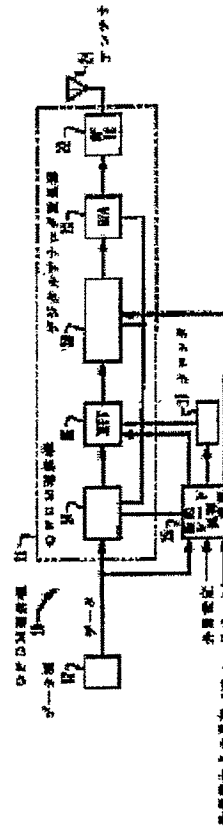

Data supplied from the esp@cenet database - Worldwide

Electronic Acknowledgement Receipt

EFS ID:	1917960
Application Number:	11199586
International Application Number:	
Confirmation Number:	1128
Title of Invention:	OFDMA with adaptive subcarrier-cluster configuration and selective loading
First Named Inventor/Applicant Name:	Xiaodong Li
Customer Number:	29053
Filer:	David H. Tannenbaum/Scott Matthews
Filer Authorized By:	David H. Tannenbaum
Attorney Docket Number:	68144/P014C1/10503148
Receipt Date:	27-JUN-2007
Filing Date:	08-AUG-2005
Time Stamp:	18:14:31
Application Type:	Utility

Payment information:

Submitted with Payment	yes
Payment was successfully received in RAM	\$ 180
RAM confirmation Number	2698
Deposit Account	

File Listing:

Document Number	Document Description	File Name	File Size(Bytes)	Multi Part /.zip	Pages (if appl.)
-----------------	----------------------	-----------	------------------	------------------	------------------

1		11199586IDS.pdf	163166	yes	4
Multipart Description/PDF files in .zip description					
	Document Description		Start	End	
	Miscellaneous Incoming Letter		1	1	
	Information Disclosure Statement (IDS) Filed		2	4	
Warnings:					
Information:					
2	NPL Documents	11199586IDSOAP014CP1J P.pdf	168196	no	4
Warnings:					
Information:					
3	Foreign Reference	11199586IDSJP11308153.p df	53344	no	1
Warnings:					
Information:					
4	Foreign Reference	11199586IDSJP1317035.pdf	60293	no	1
Warnings:					
Information:					
5	Foreign Reference	11199586IDSJP11088244.p df	53816	no	1
Warnings:					
Information:					
6	NPL Documents	11199586IDSOAP014JP.pdf	69799	no	2
Warnings:					
Information:					
7	Foreign Reference	11199586IDSWO9701256.p df	49858	no	1
Warnings:					
Information:					
8	Foreign Reference	11199586IDSJP07322219.p df	169253	no	3

Warnings:**Information:**

9	Foreign Reference	11199586IDSJP10303849.pdf	49602	no	1
---	-------------------	---------------------------	-------	----	---

Warnings:**Information:**

10	NPL Documents	11199586IDSOAP014EP.pdf	227247	no	5
----	---------------	-------------------------	--------	----	---

Warnings:**Information:**

11	Foreign Reference	11199586IDSEP0869647.pdf	821336	no	12
----	-------------------	--------------------------	--------	----	----

Warnings:**Information:**

12	Fee Worksheet (PTO-06)	fee-info.pdf	8215	no	2
----	------------------------	--------------	------	----	---

Warnings:**Information:**

Total Files Size (in bytes):	1894125
-------------------------------------	---------

This Acknowledgement Receipt evidences receipt on the noted date by the USPTO of the indicated documents, characterized by the applicant, and including page counts, where applicable. It serves as evidence of receipt similar to a Post Card, as described in MPEP 503.

New Applications Under 35 U.S.C. 111

If a new application is being filed and the application includes the necessary components for a filing date (see 37 CFR 1.53(b)-(d) and MPEP 506), a Filing Receipt (37 CFR 1.54) will be issued in due course and the date shown on this Acknowledgement Receipt will establish the filing date of the application.

National Stage of an International Application under 35 U.S.C. 371

If a timely submission to enter the national stage of an international application is compliant with the conditions of 35 U.S.C. 371 and other applicable requirements a Form PCT/DO/EO/903 indicating acceptance of the application as a national stage submission under 35 U.S.C. 371 will be issued in addition to the Filing Receipt, in due course.

New International Application Filed with the USPTO as a Receiving Office

If a new international application is being filed and the international application includes the necessary components for an international filing date (see PCT Article 11 and MPEP 1810), a Notification of the International Application Number and of the International Filing Date (Form PCT/RO/105) will be issued in due course, subject to prescriptions concerning national security, and the date shown on this Acknowledgement Receipt will establish the international filing date of the application.

Electronic Patent Application Fee Transmittal

Application Number:	11199586			
Filing Date:	08-Aug-2005			
Title of Invention:	OFDMA with adaptive subcarrier-cluster configuration and selective loading			
First Named Inventor/Applicant Name:	Xiaodong Li			
Filer:	David H. Tannenbaum/Scott Matthews			
Attorney Docket Number:	68144/P014C1/10503148			
Filed as Small Entity				
Utility Filing Fees				
Description	Fee Code	Quantity	Amount	Sub-Total in USD(\$)
Basic Filing:				
Pages:				
Claims:				
Miscellaneous-Filing:				
Petition:				
Patent-Appeals-and-Interference:				
Post-Allowance-and-Post-Issuance:				
Extension-of-Time:				

Description	Fee Code	Quantity	Amount	Sub-Total in USD(\$)
Miscellaneous:				
Submission- Information Disclosure Stmt	1806	1	180	180
Total in USD (\$)				180

Certificate of Electronic Filing Under 37 CFR 1.8

I hereby certify that this correspondence is being transmitted via the Office electronic filing system in accordance with 37 CFR 1.6(a)(4):

Commissioner for Patents
P.O. Box 1450
Alexandria, VA 22313-1450

on June 27, 2007
Date

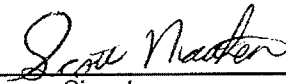

Signature

Scott Matthews

Typed or printed name of person signing Certificate

N/A
Registration Number, if applicable

(214) 855-7415
Telephone Number

Note: Each paper must have its own certificate of mailing.

Certificate of E-Filing (1 page)
Information Disclosure Statement (2 pages)
PTO Form SB-08 (1 page)
10 out of 14 References Submitted

Index of Claims



Application/Control No.

11/199,586

Examiner

Meless N. Zewdu

Applicant(s)/Patent under Reexamination

LI ET AL.

Art Unit

2617

√	Rejected
=	Allowed

-	(Through numeral) Cancelled
+	Restricted

N	Non-Elected
I	Interference

A	Appeal
O	Objected

Claim		Date									
Final	Original	6/26/07									
	1	√									
	2	√									
	3	√									
	4	√									
	5	-									
	6	-									
	7	√									
	8	√									
	9	-									
	10	-									
	11	-									
	12	√									
	13	√									
	14	√									
	15	√									
	16	√									
	17	√									
	18	√									
	19	√									
	20	√									
	21	-									
	22	-									
	23	√									
	24	-									
	25	-									
	26	√									
	27	√									
	28	-									
	29	√									
	30	√									
	31	√									
	32	√									
	33	√									
	34	-									
	35	-									
	36	√									
	37	√									
	38	-									
	39	-									
	40	-									
	41	-									
	42	-									
	43	√									
	44	√									
	45	√									
	46	√									
	47	√									
	48	√									
	49	√									
	50	-									

Claim		Date									
Final	Original	6/26/07									
	51	-									
	52	√									
	53	-									
	54	-									
	55	√									
	56	√									
	57	-									
	58	√									
	59	√									
	60	√									
	61	√									
	62	√									
	63										
	64										
	65										
	66										
	67										
	68										
	69										
	70										
	71										
	72										
	73										
	74										
	75										
	76										
	77										
	78										
	79										
	80										
	81										
	82										
	83										
	84										
	85										
	86										
	87										
	88										
	89										
	90										
	91										
	92										
	93										
	94										
	95										
	96										
	97										
	98										
	99										
	100										

Claim		Date									
Final	Original										
	101										
	102										
	103										
	104										
	105										
	106										
	107										
	108										
	109										
	110										
	111										
	112										
	113										
	114										
	115										
	116										
	117										
	118										
	119										
	120										
	121										
	122										
	123										
	124										
	125										
	126										
	127										
	128										
	129										
	130										
	131										
	132										
	133										
	134										
	135										
	136										
	137										
	138										
	139										
	140										
	141										
	142										
	143										
	144										
	145										
	146										
	147										
	148										
	149										
	150										



UNITED STATES PATENT AND TRADEMARK OFFICE

UNITED STATES DEPARTMENT OF COMMERCE
United States Patent and Trademark Office
Address: COMMISSIONER FOR PATENTS
P.O. Box 1450
Alexandria, Virginia 22313-1450
www.uspto.gov

APPLICATION NO.	FILING DATE	FIRST NAMED INVENTOR	ATTORNEY DOCKET NO.	CONFIRMATION NO.
11/199,586	08/08/2005	Xiaodong Li	68144/P014C1/10503148	1128

29053 7590 07/09/2007
FULBRIGHT & JAWORSKI L.L.P
2200 ROSS AVENUE
SUITE 2800
DALLAS, TX 75201-2784

EXAMINER

ZEWDU, MELESS NMN

ART UNIT PAPER NUMBER

2617

MAIL DATE DELIVERY MODE

07/09/2007

PAPER

Please find below and/or attached an Office communication concerning this application or proceeding.

The time period for reply, if any, is set in the attached communication.

Office Action Summary

Application No.	Applicant(s)	
11/199,586	LI ET AL.	
Examiner	Art Unit	
Meless N. Zewdu	2617	

-- The MAILING DATE of this communication appears on the cover sheet with the correspondence address --

Period for Reply

A SHORTENED STATUTORY PERIOD FOR REPLY IS SET TO EXPIRE 3 MONTH(S) OR THIRTY (30) DAYS, WHICHEVER IS LONGER, FROM THE MAILING DATE OF THIS COMMUNICATION.

- Extensions of time may be available under the provisions of 37 CFR 1.136(a). In no event, however, may a reply be timely filed after SIX (6) MONTHS from the mailing date of this communication.
- If NO period for reply is specified above, the maximum statutory period will apply and will expire SIX (6) MONTHS from the mailing date of this communication.
- Failure to reply within the set or extended period for reply will, by statute, cause the application to become ABANDONED (35 U.S.C. § 133). Any reply received by the Office later than three months after the mailing date of this communication, even if timely filed, may reduce any earned patent term adjustment. See 37 CFR 1.704(b).

Status

- 1) Responsive to communication(s) filed on 23 April 2007.
- 2a) This action is **FINAL**. 2b) This action is non-final.
- 3) Since this application is in condition for allowance except for formal matters, prosecution as to the merits is closed in accordance with the practice under *Ex parte Quayle*, 1935 C.D. 11, 453 O.G. 213.

Disposition of Claims

- 4) Claim(s) 1-4, 7, 8, 12-20, 23, 26, 27, 29-33, 36, 37, 43-49, 52, 55, 56 and 58-62 is/are pending in the application.
- 4a) Of the above claim(s) _____ is/are withdrawn from consideration.
- 5) Claim(s) _____ is/are allowed.
- 6) Claim(s) 1-4, 7, 8, 12-20, 23, 26, 27, 29-33, 36, 37, 43-49, 52, 55, 56 and 58-62 is/are rejected.
- 7) Claim(s) _____ is/are objected to.
- 8) Claim(s) _____ are subject to restriction and/or election requirement.

Application Papers

- 9) The specification is objected to by the Examiner.
- 10) The drawing(s) filed on _____ is/are: a) accepted or b) objected to by the Examiner.
Applicant may not request that any objection to the drawing(s) be held in abeyance. See 37 CFR 1.85(a).
Replacement drawing sheet(s) including the correction is required if the drawing(s) is objected to. See 37 CFR 1.121(d).
- 11) The oath or declaration is objected to by the Examiner. Note the attached Office Action or form PTO-152.

Priority under 35 U.S.C. § 119

- 12) Acknowledgment is made of a claim for foreign priority under 35 U.S.C. § 119(a)-(d) or (f).
- a) All b) Some * c) None of:
- Certified copies of the priority documents have been received.
 - Certified copies of the priority documents have been received in Application No. _____.
 - Copies of the certified copies of the priority documents have been received in this National Stage application from the International Bureau (PCT Rule 17.2(a)).

* See the attached detailed Office action for a list of the certified copies not received.

Attachment(s)

- 1) Notice of References Cited (PTO-892)
- 2) Notice of Draftsperson's Patent Drawing Review (PTO-948)
- 3) Information Disclosure Statement(s) (PTO/SB/08)
Paper No(s)/Mail Date _____
- 4) Interview Summary (PTO-413)
Paper No(s)/Mail Date. _____
- 5) Notice of Informal Patent Application
- 6) Other: _____

Art Unit: 2617

DETAILED ACTION

1. This action is in response to the communication filed on 4/23/07.
2. In reviewing applicant's request for Pre-appeal review request, some discrepancies were discovered in the final rejection. One is the use Schneller with regard to ODP. The other was that finality was made on a De abstract. A consensus was reached to **re-open prosecution** and to modify the rejection based on the now translated De document.
3. Claims 5-6, 9-11, 21-22, 24-25, 28, 34-35, 38-42, 50-51, 53-54 and 57 have been canceled.
4. Claims 1-4, 7-8, 12-20, 23, 26-27, 29-33, 36-37, 43-49, 52, 55-56 and 58-62 are pending in this action.

Claim Objections

Claim 59 is objected to because of the following informalities: the claim has been made dependant on a canceled claim 57. For examination purpose, examiner considered claim 59 as depending on claim 58. Appropriate correction is required.

Art Unit: 2617

Double Patenting

The nonstatutory double patenting rejection is based on a judicially created doctrine grounded in public policy (a policy reflected in the statute) so as to prevent the unjustified or improper timewise extension of the "right to exclude" granted by a patent and to prevent possible harassment by multiple assignees. A nonstatutory obviousness-type double patenting rejection is appropriate where the conflicting claims are not identical, but at least one examined application claim is not patentably distinct from the reference claim(s) because the examined application claim is either anticipated by, or would have been obvious over, the reference claim(s). See, e.g., *In re Berg*, 140 F.3d 1428, 46 USPQ2d 1226 (Fed. Cir. 1998); *In re Goodman*, 11 F.3d 1046, 29 USPQ2d 2010 (Fed. Cir. 1993); *In re Longi*, 759 F.2d 887, 225 USPQ 645 (Fed. Cir. 1985); *In re Van Ornum*, 686 F.2d 937, 214 USPQ 761 (CCPA 1982); *In re Vogel*, 422 F.2d 438, 164 USPQ 619 (CCPA 1970); and *In re Thorington*, 418 F.2d 528, 163 USPQ 644 (CCPA 1969).

A timely filed terminal disclaimer in compliance with 37 CFR 1.321(c) or 1.321(d) may be used to overcome an actual or provisional rejection based on a nonstatutory double patenting ground provided the conflicting application or patent either is shown to be commonly owned with this application, or claims an invention made as a result of activities undertaken within the scope of a joint research agreement.

Effective January 1, 1994, a registered attorney or agent of record may sign a terminal disclaimer. A terminal disclaimer signed by the assignee must fully comply with 37 CFR 3.73(b).

Claims 1-4, 7-8, 12-15, 17-20, 22, 26-27, 29-33, 36-37, 43-49, 52, 55-56 and 58-62 are rejected on the ground of nonstatutory obviousness-type double patenting as being unpatentable over claims 1-23 of U.S. Patent No. 6,947,748 B2. Although the conflicting claims are not identical, they are not patentably distinct from each other because the difference between the claims in the instant application and claims in the patent is that the claims in the instant application are broader than the claims in the patent. For example, consider the independent claims in the patent; each of these claims includes all or part of the features of independent claims in the instant application. But, considering the claims in the patent in general, one can find all the features claimed in the instant application present therein.

Art Unit: 2617

Claim Rejections - 35 USC § 103

The following is a quotation of 35 U.S.C. 103(a) which forms the basis for all obviousness rejections set forth in this Office action:

(a) A patent may not be obtained though the invention is not identically disclosed or described as set forth in section 102 of this title, if the differences between the subject matter sought to be patented and the prior art are such that the subject matter as a whole would have been obvious at the time the invention was made to a person having ordinary skill in the art to which said subject matter pertains. Patentability shall not be negated by the manner in which the invention was made.

Claims 1, 12, 14, 17-18, 30, 43 and 46-47 are rejected under 35 U.S.C. 103(a) as being unpatentable over Ritter (DE 19800953 C1) (translated version) in view of Larsson et al. (Larsson) (US 5,956,642).

As per claim 1: Ritter discloses a method for sub-carrier selection for a system employing orthogonal frequency division multiple access (OPDMA) (see abstract), comprising:

a subscriber unit measuring channel for a plurality of sub-carriers (page 5, lines 16-19) based on pilot symbols received from a base station (see page 7, lines 1-9; page 12, lines 12-17);

the subscriber unit selecting a set of candidate sub-carriers (see page 5, line 11- page 6, line 6);

the subscriber unit providing feedback information on the set of candidate sub-carriers to the base station (see page 5, lines 16-21);

the subscriber unit receiving an indication of sub-carriers of the set of sub-carriers selected by the base station for use by the subscriber (see page 5, line 22-page 6, line 6). Examiner considers the claimed plurality of measured sub-carriers as

Art Unit: 2617

subsets of the prior art's "various segments." Ritter also discloses that inter-cell and inter-symbol interferences are considered and compensated (see page 6, lines 19-23). But, Ritter does not explicitly teach about a subscriber unit measuring interference information, as claimed by applicant. However, in the same field of endeavor, Larsson teaches about an adaptive channel allocation wherein a mobile unit measures the interference level (I) of all N available channels (see col. 5, lines 6-21). Therefore, it would have been obvious for one of ordinary skill in the art at the time the invention was made to modify the teaching of Ritter with that of Larsson for the advantage of enabling Ritter's communication system to allocate resources adaptively with less dropped calls and better quality communication for each link (see col. 18, lines 20-39, particularly lines 28-29). 16-19).

As per claim 2: Ritter teaches a method further comprising the subscriber unit sending the indication to the base station (see page 5, lines 16-21).

As per claim 12: Ritter teaches a method wherein the pilot symbols occupy an entire OFDM frequency bandwidth (see page 3, lines 9-19).

As per claim 13: Ritter teaches a method wherein at least one other pilot symbol from a different cell transmitted at the same time as the pilot symbols received from the base station collide each other (see page 6, lines 19-23). Collision is a function of inter-cell interference.

As per claim 14: Ritter teaches a method further comprising the base station selecting the subcarriers from a set of candidate subcarriers based on additional information available to the base station (see (see page 5, line 11-page 6, line 6; page 6, lines 19-

Art Unit: 2617

23). For example, the inter-cell interference could be considered as additional information. Furthermore, examiner considers the claimed sub-carriers as being the subset of the prior art segment frequency spectrum.

As per claim 17: Ritter teaches a method wherein the indication of sub-carriers is received via a downlink control channel (see page 5, line 5-page 6, line 6; page 23, lines 8-19).

As per claim 18: Ritter teaches a method wherein the plurality of sub-carriers comprises all sub-carriers allocable by a base station (see page 5, line 11-page 6, line 6).

As per claim 30: the features of claim 30 are similar to the features of claim 1, except claim 30 is directed to an apparatus intended to perform the steps of method claim 1. Hence, since the method steps of claim 1 are taught and the apparatus of claim 30 is required to perform the steps of claim 1, claim 30 has been rejected on the same ground and motivation as claim 1.

As per claim 43: the feature of claim 43 is similar to the feature of claim 14. Hence, claim 43 is rejected on the same ground and motivation as claim 14.

As per claim 46: Ritter teaches an apparatus wherein the indication of sub-carriers is received via a downlink control channel between the base station and the at least one subscriber (see page 27, line 23-page 28, line 6). It is known to transmit/receive control information via a control channel and it is also known that a transmission from the base to the mobile unit is via a down link channel..

Art Unit: 2617

As per claim 47: Ritter teaches an apparatus wherein the plurality of sub-carriers comprises all sub-carriers allocable by a base station (see page 5, line 22-page 6, line 6; page 6, lines 7-18).

Claims 3-4, 19, 20, 23, 48, 49, 52 are rejected under 35 U.S.C. 103(a) as being unpatentable over the references applied to claim 1 above, and further in view Yan et al. (Yan) (US 6,553,011 B1).

As per claim 3: the references applied to claim 1 above do not explicitly teach about sending an indication of the group of clusters selected by the base station for use by the subscriber unit, as claimed by applicant. However, in the same field of endeavor, Yan teaches about a cellular multicarrier wireless communication system wherein mobile station is configured to receive signaling information on a common group of sub-carriers within a cluster of two or more cells, in which the base stations transmitting on the common channel are each identified from a multiple access preamble transmitted in each frame to identify the base station (see col. 2, lines 44-54; claim 6). Therefore, it would have been obvious for one of ordinary person skilled in the art at the time the invention was made to further modify the above references with the teaching of Yan for the advantage of identifying a base station from which a group of sub-carrier signals is transmitted (see col. 1, lines 48-55).

As per claim 4: Ritter teaches a method further comprising the base station selecting sub-carriers for the subscriber based on inter-cell interference avoidance (see page 6, lines 19-23).

Art Unit: 2617

As per claim 19: Ritter teaches a method wherein providing feedback information comprises arbitrary ordering the set of candidate of subcarrier (see page 19, lines 11-16; claim 4), wherein the cluster of base stations are as provided in Yan's reference, as discussed the rejection of claim 3 above. Motivation is same as provide therein (in the rejection of claim 3).

As per claim 20: the feature of claim 20 is same as that of claim 19, except listing most desirable candidate clusters first, which is taught by Ritter (see page 19, lines 4-10; claim 4).

As per claim 23: the feature of claim 23 is similar to the feature of claim 20, wherein the sequential order recited in claim 23 reads on the priority order provided in Ritter's reference, as recited and discussed in the rejection of claim 19 above. Hence, claim 23 is rejected on the same ground and motivation as claim 19.

As per claim 48: the feature of claim 48 is similar to the feature of claim 19. Hence, claim 48 is rejected on the same ground and motivation as claim 19.

As per claim 49: the feature of claim 49 is similar to the feature of claim 20. Hence, claim 49 is rejected on the same ground and motivation as claim 20.

As per claim 52: the feature of claim 52 is similar to the feature of claim 19, wherein the sequential order recited in claim 23 reads on the priority order provided in Ritter's reference, as recited in the rejection of claim 19. Hence, claim 52 is rejected on the same ground and motivation as claim 19.

Art Unit: 2617

Claims 15, 16, 44 and 45 are rejected under 35 U.S.C. 103(a) as being unpatentable over the references applied to the claims above, and further in view of Westroos et al. (Westroos) (US 6,327,472).

As per claim 15: but, the above mentioned references do not explicitly teach about a base station having additional information that comprises traffic load information on each cluster of sub-carriers, as claimed by applicant. However, in the same field of endeavor, Westroos teaches about the use of a load monitoring device that collects and holds traffic information on neighboring cells (see col. 2, line 44-col. 3, line 10; col.5, lines 19-65). Therefore, it would have been obvious for one of ordinary skill in the art at the time the invention was made to further modify the above references with the teaching of Westroos for the advantage of making load dependent channel allocation.

Note: although Westroos' traffic load information collector/holder is residing in the MSC, it is by choice of design. It could have been placed in, for example, the BSC or BS, as well.

As per claim 16:Westroos teaches a method wherein the traffic load information is provided by a data buffer in the base station (see col. 5, lines 45-65). Also, see the explanation above.

As per claim 44: but, the above mentioned references do not explicitly teach about a base station having additional information that comprises traffic load information on each cluster of sub-carriers, as claimed by applicant. However, in a related field of endeavor, Westroos teaches about the use of load monitoring device that collects and

Art Unit: 2617

holds traffic information on neighboring cells (see col. 2, line 44-col. 3, line 10; col.5, lines 19-65). Motivation is same as provided in the rejection of claim 15 above.

As per claim 45: Westroos teaches an apparatus wherein the traffic load information is provided by a data buffer in the base station (see col. 5, lines 45-65). Also, see the explanation above.

Claims 29 and 62 are rejected under 35 U.S.C. 103(a) as being unpatentable over Ritter. In view of Yan et al. and further in view of Feuerstein et al. (Feuerstein) (US 6,141,565).

As per claim 29: Ritter discloses an apparatus (see fig. 1; abstract), comprising:

a plurality of subscribers in a first cell (a cell) (see fig. 1) to generate feedback information indicating group of sub-carriers desired for use by the plurality of subscribers (see page 4, line 17-page 6, line 6). The mobile station of the prior art is in a cell.

a first base station (see fig. 1, element BS) in a first cell, the first base station performing subcarrier allocation for OFDMA to allocate OFDMA subcarriers to the plurality of subscriber units (see page 4, line 17-page 5, line 10) based on inter-cell interference avoidance in response to the feedback information (see page 6, line 19-page 7, line 9). Since there is no a second cell and a second base station mentioned, the prior art cell can be considered as a first cell and a first base station. But, Ritter does not explicitly teach about the use of a cluster of sub-carriers. However, in the same field of endeavor, Yan teaches about a cellular multi-carrier wireless communication system wherein mobile station is configured to receive signaling information on a common

Art Unit: 2617

group of sub-carriers within a cluster of two or more cells, in which the base stations transmitting on the common channel are each identified from a multiple access preamble transmitted in each frame to identify the base station (see col. 2, lines 44-54; claim 6). When the above references are modified as discussed hereinabove, the mobile feedback to the base station will include quality indication on the cluster of subcarriers. Therefore, it would have been obvious for one of ordinary person skilled in the art at the time the invention was made to further modify the above references with the teaching of Yan for the advantage of identifying a base station from which a group of sub-carrier signals is transmitted (see col. 1, lines 48-55).

But Ritter in view of Yan et al. does not explicitly teach about intra-cell traffic load balancing, as claimed by applicant. However, in a related field of endeavor, Feuerstein teaches about network optimization based on measured local interference and/or local traffic load conditions (see col. 2, lines 27-37). Therefore, it would have been obvious for one of ordinary skill in the art at the time the invention was made to modify Ritter in view of Yan with the teaching of Feuerstein's for the advantage of optimizing network parameters based on dynamic communication and network conditions such as traffic load and balancing conditions and/or changing interference conditions (see col. 1, lines 20-26).

As per claim 62: the features of claim 62 are similar to the features of claim 29. Hence, claim 62 is rejected on the same ground and motivation as claim 29.

Art Unit: 2617

Claims 58, 60 and 61 are rejected under 35 U.S.C. 103(a) as being unpatentable over Ritter in view of Frodigh et al. (Frodigh) (US 5,726,978). For examination purpose, claim 58 is considered first.

As per claim 58: Ritter discloses a method comprising:

the base station allocating sub-carriers to establish a data link between the base station and the subscriber reads on '953 (see abstract). But, Ritter does not explicitly teach about a base station allocating a first portion of the sub-carriers and allocating a second portion of the sub-carriers to the subscriber to increase communication bandwidth, as claimed by applicant. However, in the same field of endeavor, Frodigh advantageously teaches about a method of adaptively allocating selected sub-carriers to subscribers (see col. 4, lines 32-67, particularly lines 65-67). Therefore, it would have been obvious for one of ordinary skill in the art at the time the invention was made to modify Ritter's reference with the teaching of Frodigh for the advantage of lessening co-channel interference between cells of the system (see col. 4, lines 25-31). Note: adaptive allocation of sub-carriers can increase or decrease a communication bandwidth.

As per claim 59: Frodigh teaches an method wherein the base station allocates the second portion after allocating each subscriber in the cell sub-carriers to establish a data link between the base station and said each subscriber (see col. 4, lines 32-49). Adaptive allocation can allow the base station to perform this feature priority.

As per claim 60: Ritter discloses a base station (see abstract), comprising:

Art Unit: 2617

means for allocating sub-carriers to establish a data link between the base station and the subscriber (see abstract). But, Ritter does not explicitly teach about a means for allocating a first portion and a second portion of the sub-carriers to a subscriber to increase communication bandwidth, as claimed by applicant. However, in a related field of endeavor, Frodigh teaches that in an OFDMA system subcarriers can be selected and adaptively allocated based on set allocation criteria (see col. 4, lines 32-49). Therefore, it would have been obvious for one of ordinary skill in the art at the time the invention was made to modify the teaching of Ritter with that of Frodigh for the advantage of lessening co-channel interference between cells of the system (see col. 4, lines 25-31). Note: adaptive allocation of sub-carriers can increase or decrease a communication bandwidth.

As per claim 61: Frodigh teaches an apparatus defined in Claim 60 wherein the base station allocates the second portion after allocating each subscriber in the cell sub-carriers to establish a data link between the base station and said each subscriber (see col. 4, lines 32-49). When the references are combined as shown above, bandwidth will be allocated adaptively.

Art Unit: 2617

Response to Arguments

Applicant's arguments with respect to claims 1-4, 7-8, 12-15, 17-20, 22, 26-27, 29-33, 36-37, 43-49, 52, 55-56 have been considered but are moot in view of the new ground(s) of rejection.

Applicant's argument with respect to claims 58 and 60, have been fully considered; but they are not persuasive. Arguments and responses are provided in the following paragraphs.

Argument: with regard to claims 58 and 60, applicant argues by saying Frodigh is silent as to how merely selecting a portion of available subcarriers will be used to affect the communication between a base station and a subscriber unit; and as such, Frodigh falls short of disclosing allocating a second portion of subcarriers to increase communication bandwidth.

Response: examiner respectfully disagrees with the argument. In that Frodigh, in addition to selecting subcarriers, as an initial allocation, teaches about increasing communication bandwidth by reconfiguring the subset of M subcarriers (previously allocated, which can be considered as a first portion) to include unused subcarriers (second portion) (see col. 4, lines 65-67). Hence, the argument is not persuasive and the rejection is, thus, upheld.

Remark: all pending claims are rejected on the ground of nonstatutory obviousness-type double patenting but not under 35 U.S.C. 103(a). Those claims that are omitted in the later rejection are thought to have allowable subject matter in view of the prior art

Art Unit: 2617

applied therein. Such indication does not include, for example claims 32 and 33 which depend on claim 31, as having allowable subject matter.

Conclusion

Any inquiry concerning this communication or earlier communications from the examiner should be directed to Meless N. Zewdu whose telephone number is (571) 272-7873. The examiner can normally be reached on 8:30 am to 5:00 pm.

If attempts to reach the examiner by telephone are unsuccessful, the examiner's supervisor, Appiah Charles can be reached on (571) 272-7904. The fax phone number for the organization where this application or proceeding is assigned is 571-273-8300.

Information regarding the status of an application may be obtained from the Patent Application Information Retrieval (PAIR) system. Status information for published applications may be obtained from either Private PAIR or Public PAIR. Status information for unpublished applications is available through Private PAIR only. For more information about the PAIR system, see <http://pair-direct.uspto.gov>. Should you have questions on access to the Private PAIR system, contact the Electronic Business Center (EBC) at 866-217-9197 (toll-free). If you would like assistance from a USPTO Customer Service Representative or access to the automated information system, call 800-786-9199 (IN USA OR CANADA) or 571-272-1000.

Art Unit: 2617

Any inquiry of a general nature relating to the status of this application or proceeding should be directed to the receptionist whose telephone number is (571) 272-2600.

Meless zewdu

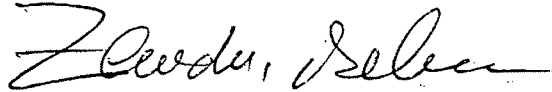

Primary examiner

26 June 2007.

Notice of References Cited

Application/Control No. 11/199,586	Applicant(s)/Patent Under Reexamination LI ET AL.	
Examiner Meless N. Zewdu	Art Unit 2617	Page 1 of 1

U.S. PATENT DOCUMENTS

*		Document Number Country Code-Number-Kind Code	Date MM-YYYY	Name	Classification
*	A	US-6,553,011 B1	04-2003	Yan et al.	370/328
	B	US-			
	C	US-			
	D	US-			
	E	US-			
	F	US-			
	G	US-			
	H	US-			
	I	US-			
	J	US-			
	K	US-			
	L	US-			
	M	US-			

FOREIGN PATENT DOCUMENTS

*		Document Number Country Code-Number-Kind Code	Date MM-YYYY	Country	Name	Classification
	N	19800953	07-1999	DE	Ritter	H04B 7/7005
	O					
	P					
	Q					
	R					
	S					
	T					

NON-PATENT DOCUMENTS

*		Include as applicable: Author, Title Date, Publisher, Edition or Volume, Pertinent Pages)
	U	
	V	
	W	
	X	

*A copy of this reference is not being furnished with this Office action. (See MPEP § 707.05(a).)
Dates in MM-YYYY format are publication dates. Classifications may be US or foreign.

PTO 07-4791

CC=DE
DATE=19990729
KIND=AN
PN=19800953

see pages 8-9 mark

Procedure and Radio Communication System to Allocate the
Radio Resources of a Radio Interface

Gerhard Ritter

UNITED STATES PATENT AND TRADEMARK OFFICE
WASHINGTON, DC June 2007
Translated by: "SCHREIBER TRANSLATIONS INC."

PUBLICATION COUNTRY (10): DE
 DOCUMENT NUMBER (11): 19800953
 DOCUMENT KIND (12): PS
 PUBLICATION DATE (43): 19990729
 APPLICATION NUMBER (21): 19800953.4-35
 APPLICATION DATE (22): 19980113
 INTERNATIONAL CLASSIFICATION (51): H04B 7/005, H04B 7/204,
 H04B 7/26, H04J 13/02, H04Q
 7/38, H04L 27/00
 PRIORITY COUNTRY (33):
 PRIORITY NUMBER (31):
 PRIORITY DATE (32):
 INVENTOR(S) (72): Gerhard Ritter
 PATENT HOLDER (73): Siemens Inc.
 DESIGNATED CONTRACTING STATES (81):
 TITLE (54): Procedure and Radio
 Communication System to
 Allocate the Radio Resources
 of a Radio Interface
 FOREIGN TITLE [54a]: Verfahren und Funk-
 Kommunikationssystem zur
 Zuteilung von Funkressourcen
 einer Funkschnittstelle

Description

The invention involves a procedure to allocate the radio resources of a radio interface of a radio communications system as well as a corresponding radio communication system.

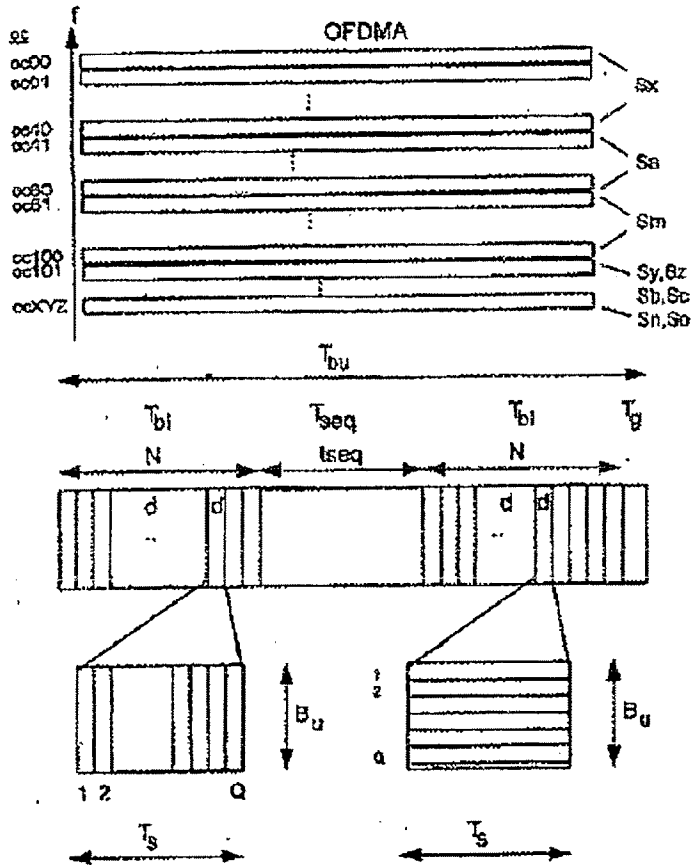

As is known radio communication systems manifest a radio interface across which data symbols can be transmitted between a fixed base station and usually several mobile station in a radio coverage area - e.g. a radio cell. In the process multiplex access procedures are

used, in order to be able to effectively use the radio resources of the radio interface. A classic multiple access procedure is the time multiplex (TDMA, Time Division Multiple Access) in which the data symbols are contained in bursts in a time slot. Another multiplex access procedure is the code multiplex (CDMA, Code Division Multiple Access) in which each data symbol is splayed with several code symbols on a certain bandwidth.

In addition, there is the OFDMA multi-carrier procedure (Orthogonal Frequency Division Multiple Access) which uses the OFDM principle to transmit the data symbols according to Chapter 15.3.2 of "Information Transmission", K. D. Kammeyer, Teubner Publishers, Stuttgart, 2nd Edition, 1996. Almost rectangular-shaped, transmission and reception filter impulse, responses enable a FFT (Fast Fourier Transformation) or an IFFT (Inverse Fast Fourier Transformation) based signal processing in the transmitter and receiver which allows for high data rates with relatively low complexity. It is also advantageous, that narrow band sub-carriers (OFDMA carriers) which, for example, can only be separated from each other by a few kilohertz enable a fine granularity of the data rates, depending on the actual application. Thus a number of sub-carriers and also a segment of a frequency spectrum can be

allocated for the communication link between the base station and the mobile station.

From German Patent DE 4441323A1 a procedure is known to transmit OFDM signals in a mobile communication system in which for high transmission rates dynamically reduced OFDM signals can be amplified by a transmission amplifier within a basically linear amplification range.

The invention has the goal of providing an improved procedure and radio communication system for allocating radio resources, when using a OFDMA multi-carrier procedure.

This goal is achieved in the invention by the procedure with the characteristics of Patent Claim 1 and by a radio communication system with the characteristics of Patent Claim 12. Further variations of the inventions can be taken from the sub-claims.

17 The procedure of the invention begins with the OFDMA multi-carrier procedure and the use of a number of sub-carriers which are assigned for the communication link between the base station and the mobile stations and includes the following steps:

- Measure the quality of various segments of the frequency spectrum through each mobile station,

- Determine at least one suitable segment preferred for its own communication link through each mobile station and the transmission of appropriate information to the base station,

5 - Evaluate the information received from the mobile stations through the base station and allocate a/2 segment for the respective communication link to each mobile station depending on the evaluation,

- Transmit information across the allocated segment to each mobile station through the base station.

11 The radio communication system of the invention also begins with the OFDMA multi-carrier procedure and the use of a number of sub-carriers which are allocated for the communication link between the base station and the mobile station and includes the following means:

16 - Control means in each mobile station to measure the quality of various segments of the frequency spectrum and to determine at least a suitable segment preferred for its own communication link,

21 - Control means in each mobile station to transmit appropriate information to the base station,

- Control means in each base station to evaluate the information received from the mobile stations and to

allocate a segment for the respective communication link to each mobile station depending on the evaluation, as well as

- Transmission means in each base station to transmit information across the assigned segment to each mobile station.

By means of the allocation system described the advantages of the OFDMA multi-carrier procedure can be used and possibly optimal frequency resources can be provided for all communication links operated by a base station with the help of a flexible allocation of several sub-carriers and a thereby defined segment of a frequency spectrum. In the process, the quality of the actual communication link plays a decisive role with respect to the frequency situation which according to the procedure of the invention can be individually changed after the determination of the best suitable segments in each mobile station overseen by a base station and can thereby be improved.

allocat

19 Another important advantage consists of the fact, that by means of the invention the interferences, especially the critical inter-cell interference in the radio communication systems and the inter-symbol interferences, are considered and compensated for.

*Inter-cell
Interfer*

23

By means of the procedure of the invention and the radio communication system a cost effective and more effective - primarily for higher frequencies in the MHz range - allocation of frequency resources is obtained using the OFDMA multi-carrier procedure, as compared to a wideband communication. The improved OFDMA multi-carrier procedure can be combined with other multiplex access procedures which transmit data symbols of a finite duration in time slot into a more effective radio system. Thus the improved OFDMA multi-carrier procedure according to an especially preferred variant can be integrated into a TDMS/CDMA radio system which for applications with less power requirements - e.g., micro-cell systems - or for TDD applications (Time Division Duplex) or for applications with higher data rates - e.g., for indoor systems, wireless systems or for applications with low movement speeds acts in an especially advantageous manner.

The flexibility of the procedure of the invention can be especially used in an advantageous manner, if segments of the frequency spectrum are allocated to the mobile /3 stations by the base station whose bandwidths vary or a /2 different number of time slots for the transmission of data symbols are assigned to the allocated segments. Thus the best suited segments for communication can be determined at

any time for individual communications links which differ from each other and they can be changed as needed.

According to another version of the invention a priority list is sent from the mobile station to the base station which contains information about the segment best suited for its communication link as well as other suitable segments preferred for its own communication link. As a result, the base station receives knowledge from the incoming lists of the desires of the mobile station with respect to the best suited segment for it and can make appropriate new assignments of the segments of the frequency spectrum for all mobile stations which are better adapted to their transmitted needs.

It has proven useful, that the number of assigned sub-carriers in a time slot be set variably by the base station for each mobile station, in order to not only change the segments when needed but to also be able to change their bandwidth.

Another advantageous model of the invention to measure the quality of segments of the frequency spectrum envisions, that the mobile station receives all sub-carriers in the time slot allocated to it, checks for each sub-carrier, whether an amplitude modulation of the data symbols transmitted in the time slot is present, and forms

an average value from the results of the test for all sub-carriers belonging to the respective segment. The advantage lies in the two-step procedure in which initially the quality is determined for the individual sub-carriers and then the quality of the sub-carriers can be ascertained to determine the quality of the segment that was examined in particular.

An especially simple method to measure quality consists of so determining the relative deviations of the amplitudes of the data symbols, that the absolute amplitude difference from data symbol to data symbol is added up and the addition result is normalized with the average amplitude of all data symbols transmitted on a given sub-carrier.

According to another variant of the invention the radio communication system manifests a mobile station with a control means to measure the quality of various segments of the frequency spectrum and to determine at least one suitable segment preferred for its communication link, as well as a transmission means to transmit suitable appropriate information to the base station.

In another variation of the invention the radio communication device manifests a device which in alternative configurations is characterized as a part of

the base station or the base station control with a control means to evaluate the information received by the mobile stations and to allocate to each mobile station a segment for the communication link depending on the evaluation, as well as a transmission means to transmit information across the allocated segment to each mobile station.

In the following section the device of the invention will be described using execution models and references to the drawings.

Shown thereby

Figure 1 is a block diagram of a mobile radio system with several mobile stations overseen by a base station, /4

Figure 2 is a schematic depiction of a structure of a radio block with data symbols in a time slot as well as the OFDMA sub-carrier to form the segments of a frequency spectrum,

Figure 3 is an information flow to allocate frequency resources to the mobile stations,

Figure 4 is a schematic depiction of the amplitude modulation of the transmitted data symbols on a OFDMA sub-carrier to measure the quality of the segments,

Figure 5 is a block diagram of a mobile station, and

Figure 6 is a block diagram of a base station / base station control.

The radio communication system shown in Figure 1 corresponds in its structure to a known mobile radio system; the network devices of a mobile radio net, like e.g., the mobile relay positions, MSC, which are networked to each other provide the access to a fixed network, PSTN, and manifest base stations, BS, connected to a base station control, BSC, and the base station controls, BSC, connected with the mobile relay positions, MSC. Such a base station, BS, is a fixed radio station which establishes and maintains communication links to the mobile stations, MS, via a radio interface. Shown in Figure 1, for example, are three radio connections between the mobile stations, MS, and a base station, BS. An Operation and Maintenance Center, OMC, performs control and maintenance functions for the mobile radio system or for parts of it. The Operation and Maintenance Center, OMC, and the base station control, BSC, usually perform the functions of regulating and adapting the allocation of radio resources within the radio cells of the base station, BS. The functionality of the radio communication system can also be conveyed to another radio communication system, if necessary, even with a fixed

mobile station, MS. The procedure of the invention can even be used in such a radio communication system.

The communication links between the base station, BS, and the mobile stations, MS, are subject to a multiple path expansion which can also be caused by reflections, for example, off buildings or vegetation, in addition to a direct expansion path. If one assumes a movement of the mobile stations, MS, then the multiple path expansion together with other interference results in the signal components of the various expansion paths of a participant's signal being overlaid in time at the

12 receiving base station, BS. It will also be assumed, that a OFDMA multi-carrier procedure is used to transmit data symbols in time slots which assigns the mobile stations a number of sub-carriers and thus a segment of a frequency spectrum for the communication link between the base station, BS, and a mobile station, MS.

17 According to the device of the invention every mobile station, MS, measures the quality of various segments of the frequency spectrum, whereby it receives all sub-carriers in the time slot assigned to it, checks the quality of each individual sub-carrier and then determines the quality of the sub-carriers. Then each mobile station determines at least a suitable segment preferred for its

own communication link and transmits appropriate information to the base station, BS. In this example the first mobile station determines a segment, Sx, with sub-carriers oc00 ... 0c40 as the best suitable segment for it. In addition, it determines the segments, Sy, Sz as additional suitable segments preferred for its own communication link. Information about segments Sx, Sy, Sz /5 is entered on a priority list, PL1, numbered according /3 to their suitability for the communication link and sent to the base station, BS.

In a similar manner, the second mobile station determines a segment, Sa, with sub-carriers oc41 ... oc60 as the suitable segment best for it. In addition, it determines segments, Sb, Sc, as additional suitable segments preferred for its own communication link. Information about segments Sa, Sb, Sc is entered on a priority list, PL2, numbered according to their suitability for the communication link and likewise is sent to the base station, BS.

Also the third mobile station, MS, overseen by the base station, BS, determines a segment, Sm, with sub-carriers, cc61 ... cc100 and the best suitable segment for its communication link. In addition, it provides in a

priority list, PL3, segments, S_n , S_o , as additional suitable segments preferred for its own communications link. The information about these three segments, S_m , S_n , S_o , which are numbered in the priority list, PL3, according to their suitability for the communication link, are also then sent to the base station, BS. It can be seen from the examples, that the number of sub-carriers $co \dots$ and thus the bandwidth of segments $S \dots$ can be variably selected.

The base station, BS, evaluates all information received from the mobile stations, MS, and assigns each mobile station a segment for the respective communication link depending on the evaluation. The base station sends the mobile station information about the assigned segment. It is assumed in this example, that each mobile station, MS, can be assigned the best suitable segment desired by it. That also depends on the transmission conditions and/or the capacity utilization of the radio cell overseen by the base station, BS, according to presets of the Operation and Maintenance Center, OMC, or the base station control, BSC, for radio resource management. Thus the first mobile station, MS, receives segment S_x , the second mobile station, MS, the segment S_a , and the third mobile station, MS, the segment S_m , accordingly with the appropriate OFDMA sub-carriers, $co \dots$, assigned by the base station, BS. A

different number of time slots to transmit data symbols in the allocated segments can also be assigned to the individual mobile stations, MS.

The flexibility of the procedure of the invention is used in an especially advantageous manner, when segments of the frequency spectrum are allocated to the mobile stations, MS, by the base station, BS, whose bandwidths are different or there are different numbers of time slots for the transmission of data symbols in the assigned segments. Thus the best suited segments for communications are determined at any time for individual communications links which differ from each other and can be changed, if needed.

Shown schematically in Figure 2 is the structure of a radio block with data symbols in a time slot, as well as the OFDMA sub-carriers to form the segments according to the examples in Figure 1. There are thus available, for example, several hundred sub-carriers, oc , - with a separation of several kilohertz between two adjacent carriers - in the radio cell of Figure 1 with three mobile stations, MS, linked to the base station, BS. Sub-carriers $oc00 \dots oc40$ define segment S_x , sub-carriers $oc41 \dots oc60$ define segment S_a , and sub-carriers $oc61 \dots oc100$ define segment S_m , appropriately distributed by the base station to the mobile stations. Other sub-carriers $oc101 \dots ocXYZ/6$

are available in the entire frequency band usable for the net operator which also contains the segments S_y , S_z and S_b , S_c , and S_n , S_o with a number of sub-carriers also categorized as suitable by the mobile stations. According to Figure 2 an identical bandwidth is assumed for segments S_x , S_m . That, however, is no prerequisite for a radio communication system in the sense of the invention.

The radio block shown as an example in Figure 2 is transmitted in a time slot of a TDMA frame structure. Provided in each frame is at least one time slot for one or more participant signals. A preset number of sub-carriers is used by the base station in each time slot on which a preset number of data symbols is transmitted. In addition, for each mobile station the number of assigned sub-carriers in a time slot can be variably adjusted by the base station.

The duration of the radio block is designated with T_{bu} . The radio block includes two blocks each with N data symbols, d , whereby each block has a length of T_{b1} . Both blocks are separated by a training sequence, t_{seq} , with a duration of T_{seq} . The end of the radio block forms a protective time, T_g , which is supposed to compensate for the running time variations because of the different distances of the mobile stations, MS, from the base station, BS. Also

shown in Figure 2 is how an individual data symbol, d , can be transmitted in a pure CDMA procedure - shown on left - or in a pure multi-carrier procedure - shown on the right. In the CDMA procedure each data symbol, d , is splayed with Q code symbols on the broadband, B_u . In the multi-carrier procedure each data symbol, d , is modulated on the Q carrier, whereby the total of the broadbands of the carrier gives the broadband, B_u . In both cases the duration the transmission of the data symbol provides the symbol duration, T_s . Thus the radio communication system is constructed as a TDMA/CDMA mobile radio system in which the data symbols, d , of several communication links can be transmitted in the frequency channels formed by the time slots, whereby the information from various links can be differentiated according to a fine structure individual for each link, for example by splaying the data symbols.

In a combination of the TDMA/CDMA mobile radio system with the OFDMA multi-carrier procedure, optimal frequency resources for all communication links overseen by a base station can be allocated according to the invention with the help of a flexible referral of several sub-carriers or a segment of the frequency spectrum defined thereby. That is especially advantageous for applications with low power requirements - e.g., micro-cell systems - or for TDD

applications (Time Division Duplex) or for applications with higher data rates - e.g., for indoor systems, wireless systems or for applications with low movement speeds. By means of the improved frequency resource referral procedure (smart frequency hopping approach) according to the invention, interferences, especially the critical inter-cell interference and the inter-symbol interferences, are considered and at least reduced or compensated for. That is therefore of significance, since for almost all radio communication systems it is a typical characteristic, that they are limited in power downlink which is even reinforced by interference.

Figure 3 shows the information flow across the radio interface for the allocation of the frequency resources to the mobile stations, MS, by the base station. Instead of a base station, BS, a base station control, BSC, can control the allocation but the base station, BS, always communicates through the air with the mobile stations, MS. In an initial step (1) the mobile stations, MS, receive in a parallel manner all sub-carriers, oc , in the time slot, ts , assigned to them. For each sub-carrier, oc , the mobile station checks as a second step (2), whether an amplitude modulation is present in the data symbols transmitted in

the time slot, t_s , and thus has a measurement result about the quality of the respective sub-carrier, o_c . It forms an average value from the results of the check for all sub-carriers belonging to a selected segment which results in a quality value for the entire segment. It can perform that for several segments - preferably in a parallel manner. Each mobile station, MS, determines in another step (3) according to the knowledge of the quality of the various segments at least one suitable, preferred segment, for example segment S_x or S_a or S_m .

16 | In another step (4) the mobile station, MS, sends via the radio interface to the base station, BS, its priority lists, $PL_1 \dots PL_3$, with the information about several preferred, suitable segments, i.e., about segments S_x, S_y, S_z or S_a, S_b, S_c or S_m, S_n, S_o for which a sequence of suitability is determined by the mobile station, MS.

In the next step (5) the base station, BS, evaluates the incoming priority lists, $PL_1 \dots PL_3$, with the information about the desired segments and decides - if necessary in a return conversation with the base station control, BSC - which segment was allocated to the respective mobile station, MS. In the example cited, the base station, BS, assigns the segments, S_x, S_a and S_m which were selected as the most suitable segments by the mobile

station to the three mobile stations, MS. For the case where the desired segment can not be allocated, one of the other segments is selected which were alternatively chosen by the mobile station, Ms. In a step (6) information about the allocated segments, S_x , S_a , and S_m is sent via the radio interface to the mobile stations, MS, which then use the received new frequency resources in the frequency spectrum for their individual communication links. To monitor as wide a frequency spectrum as possible the mobile stations, MS, each have a broadband receiver which is the case when using the OFDMA multi-carrier procedure. The point in time and thus the speed of the change of the allocation of radio resources and frequency resources can depend on the transmission conditions and/or the capacity utilization of a radio cell. It is basically possible per second in a relative frequency corresponding to the number of transmitted TDMA frames. In a mobile radio system based on a GSM standard, approximately 217 frames, for example, are transmitted per second.

Figure 4 shows a schematic depiction of the amplitude modulation of the transmitted data symbols on a OFDMA sub-carrier to measure the quality of the segments through each mobile station. By converting possibly appearing interferences or noises into an amplitude modulation from

data symbol to data symbol, the quality of the individual sub-carriers and thus the entire segment can be measured across all associated sub-carriers in a simple but effective manner. For every transmitted data symbol in a time slot an FFT signal processing is performed and the signal processing is continued in a carrier-selective

8

manner for the sub-carriers of the segment. There thus arises a resulting signal, r_s , from a wanted signal, s_s , by means of an interference signal or a noise signal, i_s , with a definite amplitude which lies between a maximum amplitude, A_{max} , and a minimum amplitude, A_{min} . If interference or noise is present, the amplitudes of the individual data symbols on a certain sub-carrier vary from data symbol to data symbol. If there is no interference or noise, the amplitudes of all data symbols manifest the same value. Relative deviations of the amplitudes of the data symbols can thereby be most easily determined, so that the absolute amplitude difference from data symbol to data symbol can be added up and the addition result can be normalized with the average amplitude of all data symbols transmitted to a predetermined sub-carrier. In this example the quality results of all 40 sub-carriers of the segment, S_x , are determined and an appropriate quality value is

determined for the segment, S_x . This is also done for a variety of other segments and a number of segments of the best quality for a communication link is determined.

A mobile station, MS, to support the procedure of the invention and the radio communication system is shown in Figure 5, while Figure 6 shows a corresponding base station, BS, or base station control, BSC. Only depicted are the means and devices essential for the object of the invention.

The mobile station, MS, manifests a control means, MSE, with a storage device, MSP, and an FFT device, FFT, a means of modulation, MOD, or a means of demodulation, DEM, and a transmitter/receiver, MHF.

Data symbols, d , of the participating signals are transmitted in both a down-link and up-link direction. For the transmission in an up-link direction they are processed by a control means, MSE, and are sent to the modulation means, MOD, for transmission. On the other hand, in the down-link direction data symbols, d , are received by the transmitter/receiver, MHF, are processed by the means of demodulation, DEM, and are sent on to the control means, MSE. Data modulation, error protection, packaging, etc. are performed in a part of the means of modulation, MOD. In addition, the data symbols, d , of a radio block are splayed

in a portion of the modulation means, MOD, corresponding to a combination of a TDMA and a CDMA procedure to achieve the fine structure specific to the individual link for the differentiation of the participating signals in a time slot. After an analog/digital conversion the radio blocks are amplified in the transmitter/receiver, MHF, and sent via the radio interface to the base station.

In the down-link direction the transmitter/receiver means, MHF, receives all sub-carriers, oc , from the air in the time slot allocated to the mobile station, MS, - see step (1) in Figure 3. The control means, MSE, is informed by the sub-carriers, oc , and conducts a measurement of the quality of various segments corresponding to the above variations. The control means, MSE, determines the suitable segments, $S \dots$, preferred for its own communication link, enters them in the priority list, and schedules the transmitter/receiver to transmit appropriate information through the air to the base station - see step (4) in Figure 3.

The transmitter/receiver, MHF, also receives the information in the down-link direction via the individual segment, $S \dots$, allocated by the base station - but at a later point in time after an evaluation of the transmitted

segments of all mobile station by the base station - see step (6) in Figure 3. In keeping with the allocated /9 frequency resources the control means, MSE, makes a /5 change of the radio parameters in the radio cell for the mobile station, MS.

At the same time because of the improved allocation procedure corresponding to the needs of the individual mobile stations, MS, the special transmission conditions (no CDMA or a multi-carrier procedure only within a certain bandwidth) and special data rates can be requested.

The device according to Figure 6 - designed as a base station, BS, or a base station control, BSC - manifests a control means, BSE, with a memory means, BSP, and an FFT device, FFT, a modulation means, MOD, or a demodulation means, DEM, and a transmitter/receiver, BHF. The transmitter/receiver, BHF, is scheduled by the control means, BSE, to transmit through the air the sub-carriers, ω_c , in the down-link direction to the mobile stations. In the opposite direction the transmitter/receiver, BHF, receives information via the segments, $S \dots$, determined by the mobile stations and sends it to the control means, BSE. Based on the evaluation of the totality of the incoming information, the control means, BSE, assigns a segment, $S \dots$, to each of its mobile stations and schedules the

transmitter/receiver, BHF, to transmit appropriate information through the air to the respective mobile station.

The change of the segments of the frequency spectrum also considers the transmission conditions (strong impediments and interference) and the utilization capacity of the radio resources (time slots, frequencies, splay code) in the radio cell. These conditions are signaled to the control means, BSE, by the base station controller, BSC, or the Operation and Maintenance Center, OMC. Then the control means, BSE, selects the sub-carriers for the definition of the segment according to the quality characteristics for each communication link.

The signal processing when using the OFDMA multi-carrier procedure by the FFT device as well as the modulation means, MOD, or the demodulation means, DEM, operates in the base station, BS, in the same manner as in the mobile station, MS, so that the above variants apply according to Figure 5. Stored in the memory device, BSP, are, among other things, the priority lists with the preferred suitable segments coming from the mobile stations.

To achieve as simple as possible a synchronization in relation to time and frequency, an initial synchronization

step is performed in which symbols with half transmission rates are sent, so that the transmitted symbols can be securely received in a time window, even with completely unsynchronized conditions. With the use of micro-cells only, a synchronization of the mobile stations to the base station is required.

A base station code can be formed to identify the base station, whereby the phases of the data symbols transmitted between at least two adjacent sub-carriers at a first position in the radio block are used. Preferably these are two sub-carriers which lie in the center of a data stream with several sub-carriers. Thus the phase 0 degrees is assigned to the first data symbol on the sub-carrier with the lower frequency. The phase of the first data symbol of the adjacent sub-carrier with the higher frequency forms the base station code, i.e., with the values 0 degrees, 90 degrees, 180 degrees and 270 degrees. The phases of the first symbols of both adjacent sub-carriers can also be used as a phase reference to detect information on all sub-carriers.

From the above remarks it can be seen, that the

10

procedure of the invention is especially suitable for use in future radio communications systems, like the UMTS

(Universal Mobile Communication System) or the FPLMTS
(Future Public Land Mobile Telecommunication System).

Patent Claims

1. Procedure to allocate the radio resources of a radio interface of a radio communications system, whereby

- data symbols (d) are transmitted in time slots (ts) across a radio interface between a base station (BS) and several mobile stations (MS) overseen by the base station (BS), and

- an OFDMA multi-carrier procedure is used to transmit the data symbols (d) which allocates to the mobile stations (MS) a number of sub-carriers (oc) and thus a segment (S ...) of a frequency spectrum for the communication link between the base station (BS) and the mobile station (MS),

with the following procedural steps: *cb*

- measurement of the quality of various segments (S ...) the frequency spectrum by each mobile station (MS),
- determination by each mobile station (MS) of at least one suitable segment (S_x ... S_a ... S_m...) preferred for its own communication link and transmission of appropriate information to the base station (BS),
- evaluation of the information received from the mobile stations (MS) by the base station (BS) and

23

assignment of a segment (Sx, Sa, Sm) for the respective communication link to each mobile station (MS) depending on the evaluation, as well as - transmission of information about the assigned segment (Sx, Sa, Sm) to each mobile station (MS) by the base station (BS).

Allegri

2. Procedure according to Claim 1 in which at least two mobile station (MS) are assigned segments (Sx, Sa) of the frequency spectrum by the base station whose bandwidths differ from each other.

3. Procedure according to Claim 1 or 2 in which the mobile station (MS) is assigned a different number of time slots (ts) by the base station (BS) for the transmission of data symbols (d) in the assigned segments.

Priority List

4. Procedure according to one of the previous claims in which a priority list (PL1, PL2, PL3) is sent from the mobile station (MS) to the base station (BS) which contains information about a best suited segment (Sx, Sa, Sm) for its own communication link, as well as other suitable segments (Sy, Sz; Sb, Sc; Sn, So) preferred for its own communication link.

5. Procedure according to one of the previous claims in which a predetermined number of sub-carriers (oc) is used

by the base station (BS) in each time slot on which a predetermined number of data symbols (d) is transmitted.

6. Procedure according to one of the previous claims in which the number of allocated sub-carriers (oc) in a time slot (ts) for each mobile station (MS) can be variably adjusted by the base station.

7. Procedure according to one of the previous claims in

which in order to measure the quality of the segments /6

(S ...) of the frequency spectrum by the mobile station

- all sub-carriers (oc) are received in the time slot allocated to it,

- a check is made for each sub-carrier (oc), whether an amplitude modulation of the data symbols (d)

transmitted in the time slot is present and an average value is formed from the results of the test for all sub-carriers (oc) belonging to the respective segment (S ...).

8. Procedure according to Claim 7 in which relative deviations of the amplitudes of the data symbols (d) are so determined, that the absolute amplitude difference from data symbol to data symbol is added up and the addition result is normalized with the average amplitude of all data symbols transmitted on a predetermined sub-carrier (oc).

9. Procedure according to Claim 7 or 8 in which several segments (e.g., Sx, Sy, Sz) of the best quality are determined by the mobile station (MS) and are numbered in a priority list (e.g., PL1) corresponding to increasing amplitude modulation.

10. Procedure according to one of Claims 7 to 9 in which an amplitude modulation is then determined, when the amplitudes of the data symbols (d) transmitted on a certain sub-carrier (oc) differ from data symbol to data symbol because of interferences or noises.

11. Procedure according to one of the previous claims in which the radio communication system is designed as a TDMA/CDMA mobile radio system in which data symbols (d) of several communication links can be simultaneously transmitted in frequency channels formed by time slots, whereby the information of various communication links can differ according to the fine structure of individual links.

12. Radio communication system to allocate radio resources of a radio interface, whereby

- data symbols (d) are transmitted in time slots (ts) across a radio interface between a base station (BS) and several mobile stations (MS) overseen by the base station,

- an OFDMA multi-carrier procedure is used to transmit the data symbols (d) which allocates to the mobile stations (MS) a number of sub-carriers (oc) and thus a segment (S ...) of a frequency spectrum for the communication link between the base station (BS) and the mobile station (MS),

with

- a control means (MSE) in each mobile station (MS) to measure the quality of various segments (S ...) of the frequency spectrum and to determine at least one suitable segment (Sx ... Sa ... Sm...) preferred for its own communication link,

- a transmitter (MHF) in each mobile station (MS) to transmit appropriate information to the base station (BS),

- a control means (BSE) in each base station (BS) to evaluate the information received from the mobile stations (MS) and to allocate a segment (Sx, Sa, Sm) for the respective communication link to each mobile

station (MS) depending on the evaluation, as well as

- a transmitter (HF) in each base station to transmit information about the allocated segments (Sx, Sa, Sm) to each base station.

13. Radio communication system according to Claim 12 with a mobile station which manifests

- a control means (MSE) to measure the quality of various segments (S ...) of the frequency spectrum and to determine at least one suitable segment (Sx, Sa, Sm) preferred for its own communication link, and
- a transmitter (MHF) to transmit appropriate information to the base station (BS).

14. Radio communication system according to Claim 12 or 13 with a device which manifests

- a control means (MSE) to evaluate the information received from the mobile stations (MS) and to allocate a segment (Sx, Sa, Sm) for the communication link to each mobile station (MS) depending on the evaluation, as well as
- a transmitter (BHF) to transmit information about the allocated segments (Sx, Sa, Sm) to each mobile station (MS).

15. Radio communication system according to Claim 14 in which the control means (BSE) performs the evaluation of the information received from the mobile stations and the allocation of the segments (Sx, Sa, Sm) for the respective communication links to the mobile stations (MS) corresponding to the transmission conditions and/or the

utilization capacity of a radio cell according to input data from a device (BSC, OMC) for radio resource management.

16. Radio communication system according to Claim 14 or 15 in which the device is constructed as a part of the base station (BS).

17. Radio communication system according to Claim 14 or 15 in which the device is constructed as a part of the base station control (BSC).

FIG 1

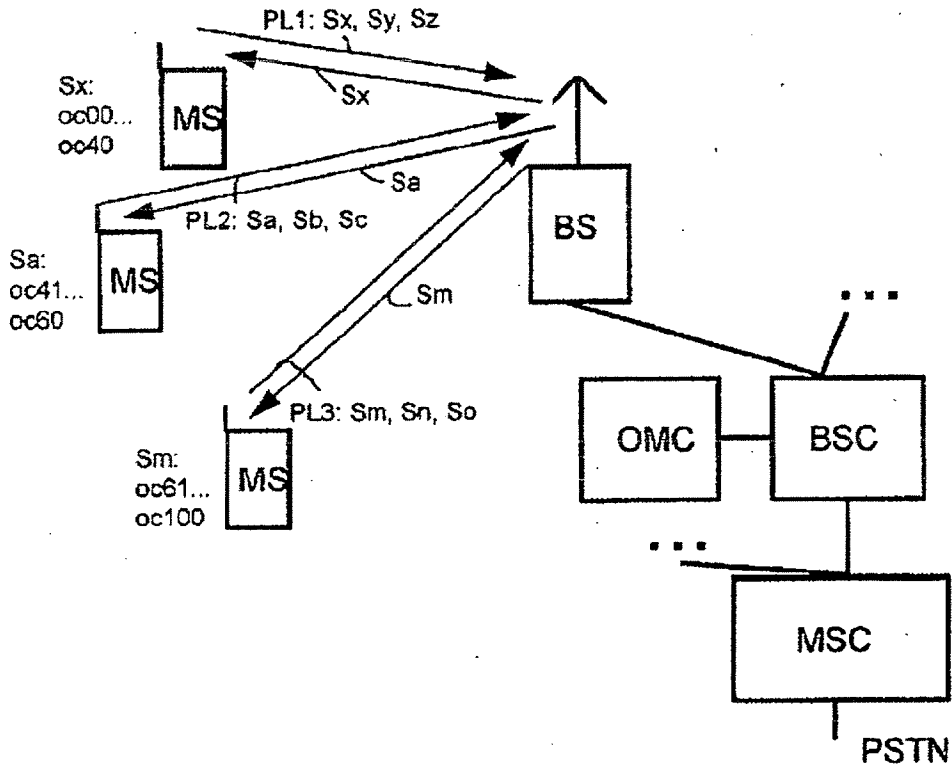

FIG 4

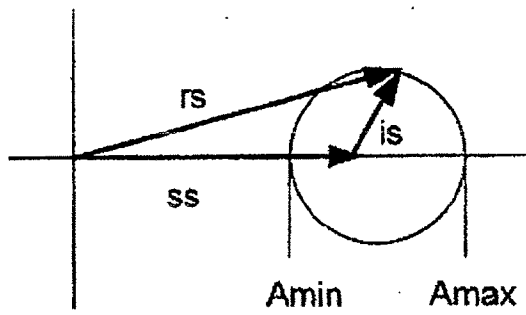
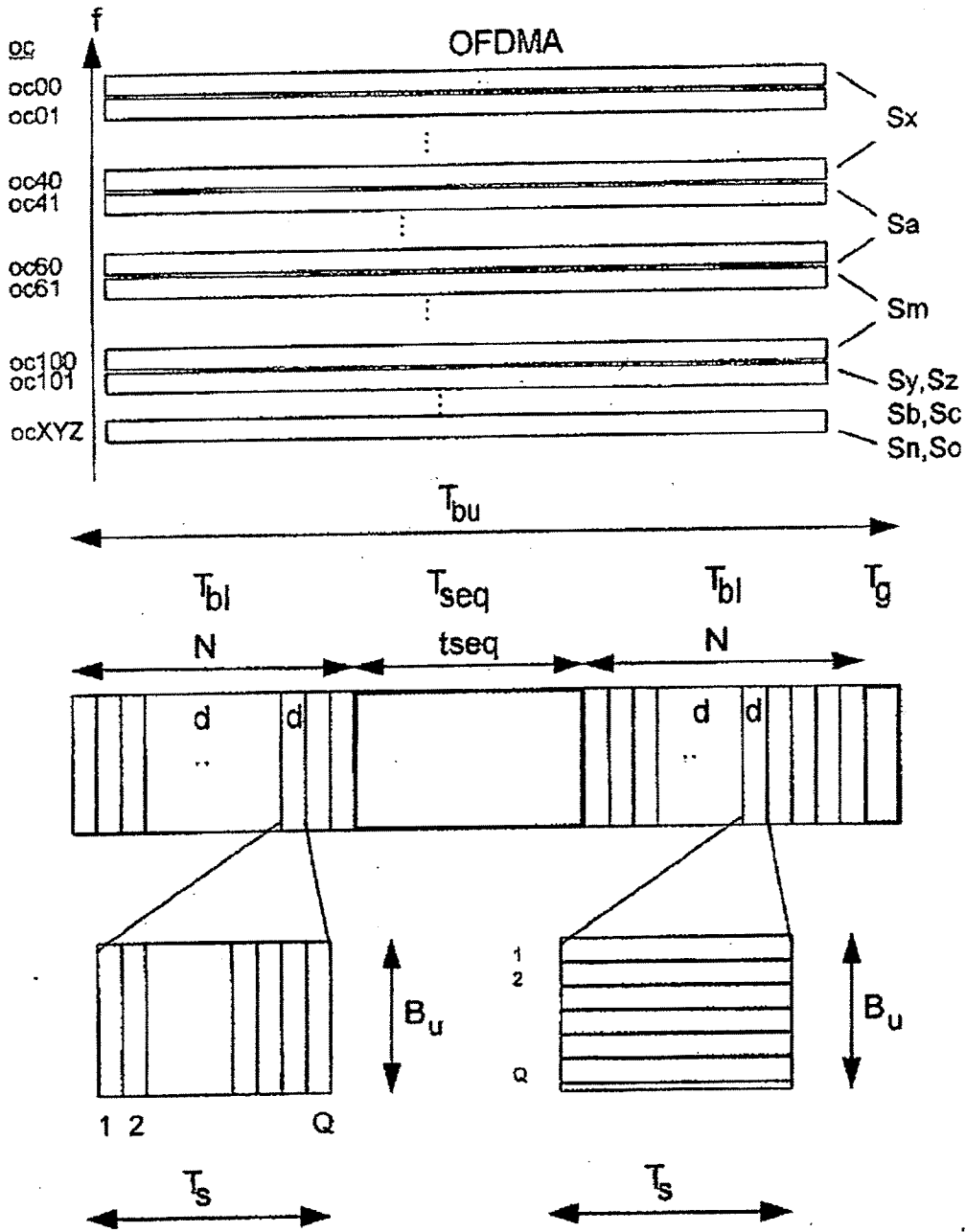

FIG 2



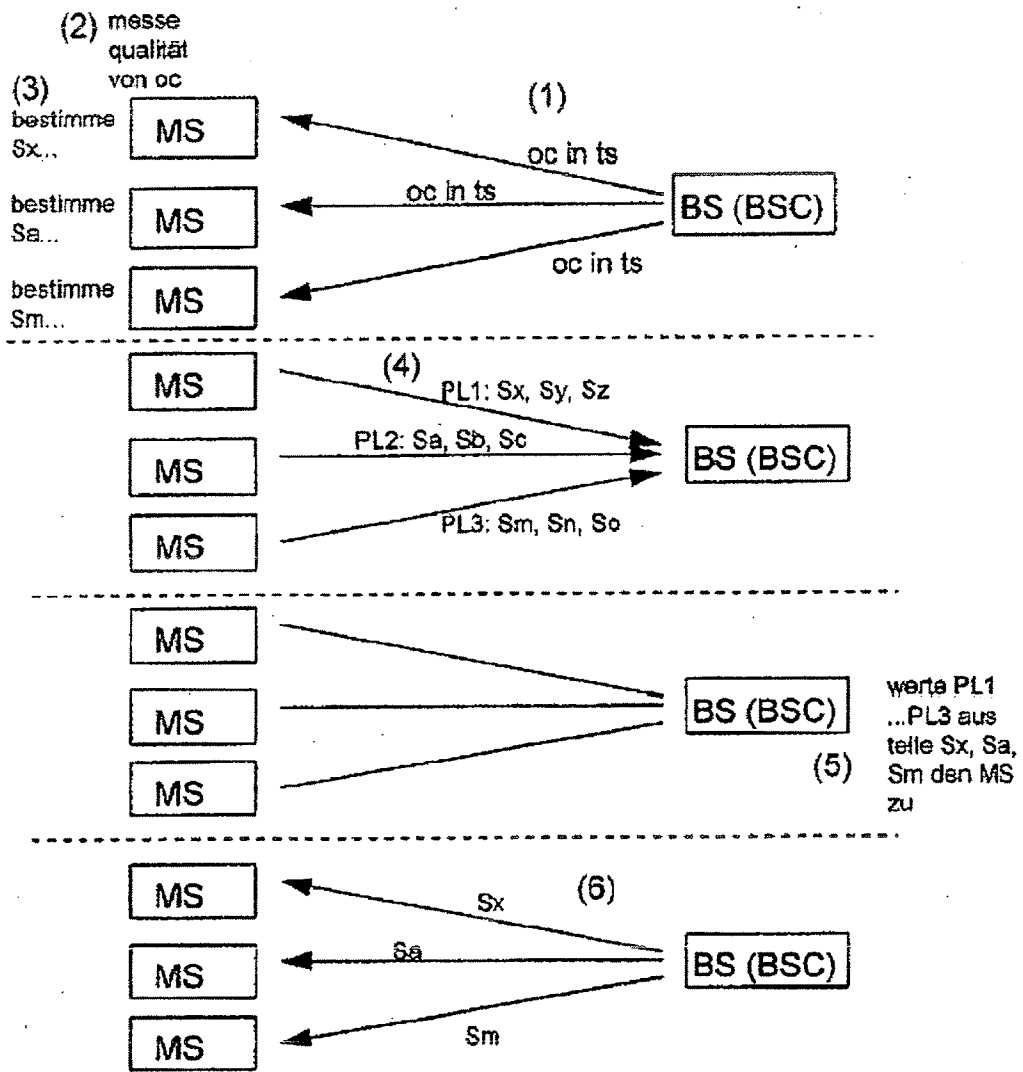

FIG 3

FIG 5

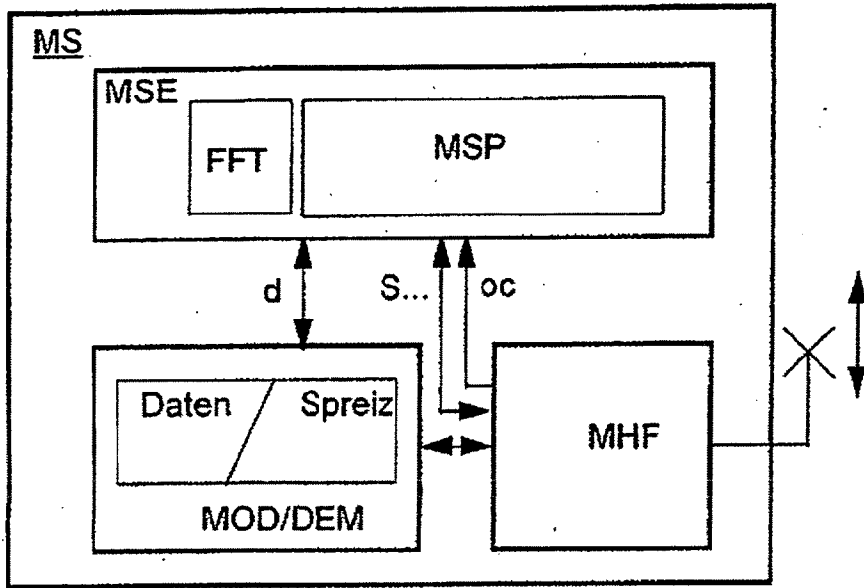
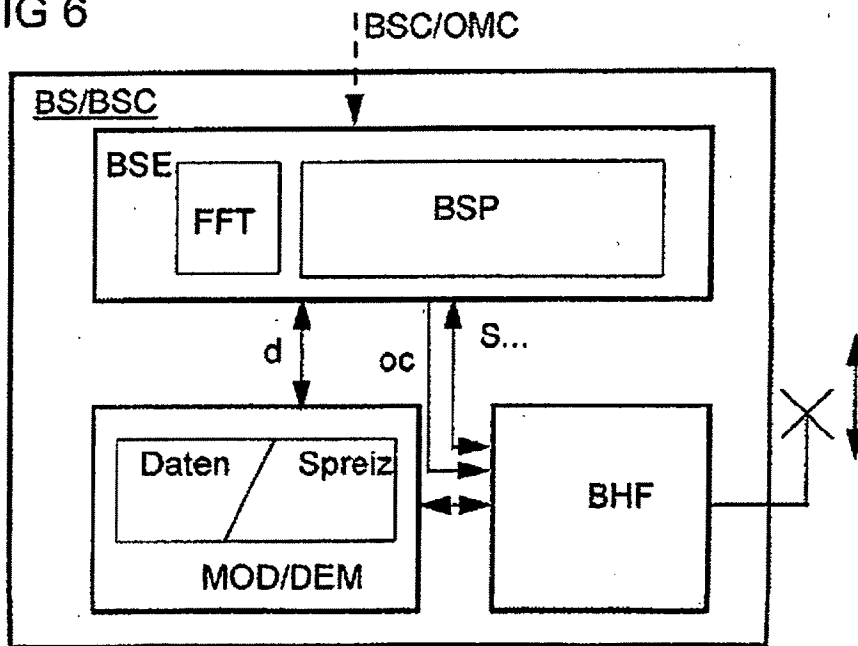

FIG 6



IN THE UNITED STATES PATENT AND TRADEMARK OFFICE

In re Patent Application of:
Xiaodong Li et al.

Application No.: 11/199,586

Confirmation No.: 1128

Filed: August 8, 2005

Art Unit: 2617

For: OFDMA WITH ADAPTIVE SUBCARRIER-
CLUSTER CONFIGURATION AND
SELECTIVE LOADING

Examiner: M. N. Zewdu

APPEAL BRIEF

MS Appeal Brief - Patents
Commissioner for Patents
P.O. Box 1450
Alexandria, VA 22313-1450

Dear Sir:

As required under 37 C.F.R. § 41.37(a), this brief is filed concurrently with a Notice of Appeal and in response to the Non-Final Office Action mailed on July 9, 2007.

The fees required under 37 C.F.R. § 41.20(b)(2) are dealt with in the accompanying TRANSMITTAL OF APPEAL BRIEF.

This brief contains items under the following headings as required by 37 C.F.R. § 41.37 and M.P.E.P. § 1206:

- I. Real Party In Interest
- II. Related Appeals and Interferences
- III. Status of Claims
- IV. Status of Amendments
- V. Summary of Claimed Subject Matter
- VI. Grounds of Rejection to be Reviewed on Appeal
- VII. Argument
- VIII. Claims Appendix
- IX. Evidence Appendix
- X. Related Proceedings Appendix

I. REAL PARTY IN INTEREST

The real party in interest for this appeal is:

Adaptix, Inc., located at 605 - 5th Avenue S., Suite 800, Seattle, WA 98104.

II. RELATED APPEALS, INTERFERENCES, AND JUDICIAL PROCEEDINGS

There are no other appeals, interferences, or judicial proceedings which will directly affect or be directly affected by or have a bearing on the Board's decision in this appeal.

III. STATUS OF CLAIMS

A. Total Number of Claims in Application

There are 40 claims pending in application.

B. Current Status of Claims

1. Claims canceled: 5, 6, 9-11, 21, 22, 24, 25, 34, 35, 38-42, 50, 51, 53, 54, and 57
2. Claims withdrawn from consideration but not canceled: None
3. Claims pending: 1-4, 7, 8, 12-20, 23, 26-33, 36, 37, 43-49, 52, 55, 56, and 58-62
4. Claims allowed: None
5. Claims objected: 59
6. Claims rejected: 1-4, 7, 8, 12-20, 23, 26-33, 36, 37, 43-49, 52, 55, 56, and 58-62
7. Claims considered to have allowable subject matter in view of the references cited by the Examiner: 7, 8, 26, 27, 31, 32, 33, 36, 37, 55, 56

C. Claims On Appeal

The claims on appeal are claims 1-4, 7, 8, 12-20, 23, 26-33, 36, 37, 43-49, 52, 55, 56, and 58-62.

IV. STATUS OF AMENDMENTS

Applicant did not file an Amendment After Final Rejection.

V. SUMMARY OF CLAIMED SUBJECT MATTER

According to claim 1, a method for subcarrier selection for a system employing orthogonal frequency division multiple access (OFDMA). The method includes a subscriber unit (Figure 1A) measuring channel and interference information for a plurality of subcarriers (page 8, lines 14-15) based on pilot symbols received from a base station (FIGURE 1B; page 15, lines 8-9, and lines 17-19). The method further includes the subscriber unit selecting a set of candidate subcarriers (page 8, lines 15-17), the subscriber unit providing feedback information on the set of candidate subcarriers to the base station (FIGURE 1B; page 8, lines 17-18), and the subscriber unit receiving an indication of subcarriers of the set of subcarriers (page 18, lines 1-2) selected by the base station for use by the subscriber unit (page 9, lines 6-7).

According to claim 2, the method defined in claim 1 further comprising the subscriber unit sending the indication to the base station (page 9, lines 1-5).

According to claim 3, the method defined in claim 2 further comprising sending an indication of the group of clusters (page 14, lines 12-14) selected by the base station for use by the subscriber unit (page 18, lines 1-3).

According to claim 4, the method defined in claim 3 further comprising the base station selecting subcarriers for the subscriber unit based on inter-cell interference avoidance (page 17, lines 18-19).

According to claim 7, the method defined in claim 1 further comprising the subscriber unit submitting new feedback information after being allocated the set of subscriber units to be allocated a new set of subcarriers (page 18, lines 7-8; page 19, lines 12-14) and thereafter the subscriber unit receiving another indication of the new set of subcarriers (page 19, line 15).

According to claim 8, the method defined in claim 1 further comprising the subscriber unit using information from pilot symbol periods and data periods to measure channel and interference information (page 24, lines 7-9).

According to claim 12, the method defined in claim 1 wherein the pilot symbols occupy an entire OFDM frequency bandwidth (FIGURES 2A-C; page 21, lines 7-8).

According to claim 13, the method defined in claim 12 wherein at least one other pilot symbol from a different cell transmitted at the same time as the pilot symbols received from the base station collide with each other (page 22, lines 18-19).

According to claim 14, the method defined in claim 1 further comprising the base station selecting the subcarriers from the set of candidate subcarriers based on additional information available to the base station (page 9, lines 6-8).

According to claim 15, the method defined in Claim 14 wherein the additional information comprises traffic load information on each cluster of subcarriers (page 9, lines 8-9).

According to claim 16, the method defined in claim 15 wherein the traffic load information is provided by a data buffer in the base station (FIGURE 14; page 32, lines 13-14).

According to claim 17, the method defined in claim 1 wherein the indication of subcarriers is received via a downlink control channel (page 18, line 2).

According to claim 18, the method defined in claim 1 wherein the plurality of subcarriers comprises all subcarriers allocable by a base station (page 8, lines 14-16).

According to claim 19, the method defined in claim 1 wherein providing feedback information comprises arbitrarily ordering the set of candidate of subcarriers as clusters of subcarriers (page 17, lines 3-6).

According to claim 20, the method defined in claim 19 wherein arbitrarily order candidate clusters comprise clusters in an order with most desirable candidate clusters being listed first (page 17, lines 6-8).

According to claim 23, the method defined in claim 1 wherein providing feedback information comprises sequentially ordering candidate clusters (page 9, lines 3-5).

According to claim 26, the method defined in claim 1 further includes the base station allocating a first portion of the subcarriers to establish a data link between the base station and the subscriber unit (page 18, lines 11-13); and then the base station allocating a second portion of the subcarriers to the subscriber unit to increase communication bandwidth (page 18, lines 13-16).

According to claim 27, the method defined in claim 26 wherein the base station allocates the second portion after allocating each subscriber unit in the cell subcarriers to establish a data link between the base station and said each subscriber unit (page 18, lines 17-19; page 19, line 1).

According to claim 29, an apparatus for subcarrier allocation is described. The apparatus includes a plurality of subscriber units in a first cell to generate feedback information indicating clusters of subcarriers desired for use by the plurality of subscriber units (page 9, lines 1-5); and a first base station in the first cell (page 8, line 18), the first base station performing subcarrier allocation for OFDMA to allocate (page 18, lines 10-11) OFDMA subcarriers in clusters to the plurality of subscriber units based on inter-cell interference avoidance and intra-cell traffic load balancing in response to the feedback information (page 25, lines 16-19).

According to claim 30, another apparatus for subcarrier allocation is described. The apparatus includes a plurality of subscriber units in a first cell operable to generate feedback information indicating clusters of subcarriers desired for use by the plurality of subscriber units (page 9, lines 1-5); and a first base station in the first cell (page 8, line 18), the first base station operable to allocate (page 18, lines 10-11) OFDMA subcarriers in clusters to the plurality of subscriber units. Each of said plurality of subscriber units to measure channel and interference information for the plurality of subcarriers (page 8, lines 14-15) based on

pilot symbols received from the first base station (FIGURE 1B; page 15, lines 8-9, and lines 17-19) and at least one of the plurality of subscriber units to select a set of candidate subcarriers from the plurality of subcarriers (page 8, lines 15-17), and said at least one subscriber unit to provide feedback information on the set of candidate subcarriers to the base station (FIGURE 1B; page 8, lines 17-18) and to receive an indication of subcarriers from the set of subcarriers selected by the first base station for use by the at least one subscriber unit (page 18, lines 1-2).

According to claim 31, the apparatus defined in claim 30 wherein each of the plurality of subscriber units continuously monitors reception of the pilot symbols known to the base station and the plurality of subscriber units and measures signal-plus-interference-to-noise ratio (SINR) of each cluster of subcarriers (page 15, lines 17-19).

According to claim 32, the apparatus defined in claim 31 wherein each of the plurality of subscriber units measures inter-cell interference (page 16, lines 11-12), wherein the at least one subscriber unit selects candidate subcarriers based on the inter-cell interference (page 16, lines 1-2).

According to claim 33, the apparatus defined in claim 32 wherein the base station selects subcarriers for the one subscriber unit based on inter-cell interference avoidance (page 17, lines 18-19).

According to claim 36, the apparatus defined in claim 30 wherein the subscriber unit submits new feedback information after being allocated the set of subscriber units to receive a new set of subcarriers (page 19, lines 12-14) and thereafter receives another indication of the new set of subcarriers (page 19, lines 14-15).

According to claim 37, the apparatus defined in claim 30 wherein the at least one subscriber unit uses information from pilot symbol periods and data periods to measure channel and interference information (page 24, lines 7-9).

According to claim 43, the apparatus defined in claim 30 wherein the base station selects the subcarriers from the set of candidate subcarriers based on additional information available to the base station (page 9, lines 6-8).

According to claim 44, the apparatus defined in claim 43 wherein the additional information comprises traffic load information on each cluster of subcarriers (page 9, lines 8-9).

According to claim 45, the apparatus defined in claim 44 wherein the traffic load information is provided by a data buffer in the base station (Figure 14; page 32, lines 13-14).

According to claim 46, the apparatus defined in claim 30 wherein the indication of subcarriers is received via a downlink control channel between the base station and the at least one subscriber unit (page 18, lines 1-3).

According to claim 47, the apparatus defined in claim 30 wherein the plurality of subcarriers comprises all subcarriers allocable by a base station (page 8, lines 14-16).

According to claim 48, the apparatus defined in claim 30 wherein the plurality of subscriber units provide feedback information that comprises an arbitrarily ordered set of candidate subcarriers as clusters of subcarriers (page 17, lines 3-6).

According to claim 49, the apparatus defined in claim 48 wherein arbitrarily order candidate clusters comprise clusters in an order with most desirable candidate clusters being listed first (page 17, lines 6-8).

According to claim 52, the apparatus defined in claim 30 wherein providing feedback information comprises sequentially ordering candidate clusters. (page 9, lines 3-5)

According to claim 55, the apparatus defined in claim 30 wherein the base station allocates a first portion of the subcarriers to establish a data link between the base station and the subscriber unit (page 18, lines 11-13); and then allocates a second portion of the subcarriers to the subscriber unit to increase communication bandwidth (page 18, lines 13-16).

According to claim 56, the apparatus defined in claim 55 wherein the base station allocates the second portion after allocating each subscriber unit in the cell subcarriers to establish a data link between the base station and said each subscriber unit (page 18, lines 17-19; page 19, line 1).

According to claim 58, a method for subcarrier allocation is described. The method includes a base station allocating a first portion of a plurality of subcarriers to establish a data link between the base station and a subscriber unit (page 18, lines 11-13); and the base station allocating a second portion of said plurality of subcarriers to the subscriber unit to increase communication bandwidth (page 18, lines 13-16).

According to claim 59, the method defined in claim 57 wherein the base station allocates the second portion after allocating each subscriber unit in the cell subcarriers to establish a data link between the base station and said each subscriber unit (page 18, lines 17-19; page 19, line 1).

According to claim 60, a base station is described. The base station includes means for allocating a first portion of a plurality of subcarriers to establish a data link between the base station and a subscriber unit (page 18, lines 11-13); and means for allocating a second portion of said plurality of subcarriers to the subscriber unit to increase communication bandwidth (page 18, lines 13-16).

According to claim 61, the apparatus defined in claim 60 wherein the base station allocates the second portion after allocating each subscriber unit in the cell subcarriers to establish a data link between the base station and said each subscriber unit (page 18, lines 17-19; page 19, line 1).

According to claim 62, an apparatus is described. This apparatus includes a plurality of subscriber units in a cell (FIGURES 1A, 2A-2C); and a base station in the cell (page 8, line 18), the base station to perform subcarrier allocation for OFDMA to allocate OFDMA subcarriers in clusters to the plurality of subscriber units based on inter-cell interference avoidance and intra-cell traffic load balancing (page 25, lines 16-19).

VI. GROUNDS OF REJECTION TO BE REVIEWED ON APPEAL

A. First Ground of Rejection

Claims 1-4, 7, 8, 12-15, 17-20, 22, 26-27, 29-33, 36-37, 43-49, 52, 55, 56, and 58-62 are rejected on the ground of nonstatutory obviousness-type double patenting as being unpatentable over claims 1-23 of U.S. Patent No. 6,947,748 B2.

B. Second Ground of Rejection

Claims 1, 2, 12-14, 17, 18, 30, 43, and 46-47 are rejected under 35 U.S.C. § 103(a) as being unpatentable over Ritter (DE 19800953 C1, translated version) (hereinafter Ritter) in view of Larsson et al. (U.S. Patent No. 5,956,642) (hereinafter Larsson). Although the Examiner did not include claims 2 and 13 in his summary of claims rejected under this ground, the Examiner addressed claims 2 and 13 in the discussion. Thus, as best Appellant understands, claims 2 and 13 are included in this section accordingly.

C. Third Ground of Rejection

Claims 3, 4, 19, 20, 23, 48, 49, and 52 are rejected under 35 U.S.C. § 103(a) as being unpatentable over the references applied to claim 1, and further in view of Yan et al. (U.S. Patent No. 6,553,011 B1) (hereinafter Yan).

D. Fourth Ground of Rejection

Claims 15, 16, 44, and 45 are rejected under 35 U.S.C. § 103(a) as being unpatentable over the references applied to the claims in the Third Ground of Rejection, and further in view of Westroos et al. (U.S. Patent No. 6,327,472) (hereinafter Westroos).

E. Fifth Ground of Rejection

Claims 29 and 62 are rejected under 35 U.S.C. § 103(a) as being unpatentable over Ritter in view of Yan and further in view of Feuerstein et al. (U.S. Patent No. 6,141,565) (hereinafter Feuerstein).

F. Sixth Ground of Rejection

Claims 58-61 are rejected under 35 U.S.C. § 103(a) as being unpatentable over Ritter in view of Frodigh et al. (U.S. Patent No. 5,726,978) (hereinafter Frodigh). Although the Examiner did not include claim 59 in his summary of claims rejected under this ground, the Examiner addressed claim 59 in the discussion. Thus, as best Appellant understands, claim 59 is included in this section accordingly.

VII. ARGUMENT

A. First Ground of Rejection

Claims 1-4, 7, 8, 12-15, 17-20, 22, 26-27, 29-33, 36-37, 43-49, 52, 55, 56, and 58-62 are rejected on the ground of nonstatutory obviousness-type double patenting as being unpatentable over claims 1-23 of U.S. Patent No. 6,947,748 B2.

In the Current Action, the Examiner bases the non statutory double patenting rejection upon the notion that “the difference between the claims in the instant application and the claims in the [issued] patent is that the claims in the instant application are broader than the claims in the [issued] patent.” *See* Current Action, page 3. Appellant submits the idea that the pending claims may be broader than the issued claims (which form the basis of the rejection) is not, by itself, an appropriate rationale for a double patenting rejection. Non-statutory double patenting requires rejection of an application claim “when the claimed subject matter is not patentably distinct from the subject matter claim in the commonly owned patent.” *See* M.P.E.P. 804(II)(B)(1). In the case at hand, the Examiner’s assertion that the pending claims are broader than the issued claims is not determinative as to whether or not the pending claims are patentably distinct in view of the issued claims. Appellant respectfully notes that the Examiner’s statement is immaterial with respect to double patenting. As the Manual of Patent Examining Procedure correctly explains, “[d]omination and double patenting should not be confused Domination by itself, i.e., in the absence of statutory or nonstatutory double patenting grounds, cannot support a double patenting rejection.” *In re Kaplan*, 789 F.2d 1574, 1577-78 (Fed. Cir. 1986), *cited in* M.P.E.P. § 804(II). As such, the Examiner has not provided a sufficient double patenting rejection. Therefore, Appellant requests reversal of the rejection of record.

B. Second Ground of Rejection

Claims 1, 2, 12-14, 17, 18, 30, 43, and 46-47 are rejected under 35 U.S.C. § 103(a) as being unpatentable over Ritter in view of Larsson.

In rejecting claims under 35 U.S.C. § 103, the Examiner bears the initial burden of establishing a prima facie case of obviousness. *In re Piasecki*, 745 F.2d 1468, 1472 (Fed. Cir. 1984). The Examiner can satisfy this burden by showing some articulated reasoning

with some rational underpinning to support the legal conclusion of obviousness. *KSR Int'l. v. Teleflex Inc.*, 127 S. Ct 1727, 1741 (2007) (citing *In re Kahn*, 441 F.3d 977, 988 (Fed. Cir. 2006)). Only if this initial burden is met does the burden of coming forward with evidence or argument shift to the Appellant. *Piasecki*, 745 F.2d at 1472. Thus, the Examiner must not only assure that the requisite findings are made, based on evidence of record, but must also explain the reasoning by which the findings are deemed to support the Examiner's conclusion. Without conceding Examiner explained the reasoning by which the findings are deemed to support his conclusion, Appellant respectfully asserts that the Examiner's rejection fails to satisfy the requisite findings.

Independent claim 1 recites "measuring channel and interference information for a plurality of subcarriers based on pilot symbols received from a base station." Independent claim 30 recites a similar limitation. In the Current Action, the Examiner relies on Ritter, at page 5, lines 16-19, as satisfying the recited "measuring channel" and Larsson, at col. 5, lines 6-21, as satisfying the recited "measuring interference." See Current Action, pages 4-5. Furthermore, the Examiner cites to Ritter, at page 7, lines 1-9; page 12, lines 12-17, as satisfying measuring "based on pilot symbols received from a base station." *Id.* at page 4. However, Appellant respectfully disagrees with Examiner's characterization of Ritter and Larsson. Appellant points out there is no suggestion in either reference of a subscriber unit measuring channel and interference information based on pilot symbols received from a base station. However, Ritter generally describes OFDM communication between a base station and subscriber, which the Examiner appears to equate to "data symbols" in the OFDM communication and to "pilot symbols" recited by claims 1 and 30. See Current Action, page 4; Ritter, page 7, lines 1-9; page 12, lines 12-7. The cited segments in Ritter merely discuss that the improved OFDMA multi-carrier procedure will transmit these "data symbols" more effectively. See Ritter, page 7, lines 1-9; page 12, lines 12-7. In any event, Appellant respectfully asserts that Ritter's data symbols are not the same as pilot symbols received from a base station, as set forth in the claims.

Appellant's argument is further supported by reference Ritter at page 9 lines 8-14, which discusses measuring the quality of various segments of the frequency spectrum by determining the relative deviations of the amplitudes of the data symbols. However, Appellant reemphasizes that this description is different than what is required in claims 1 and

30, which is “measuring channel and interference information for a plurality of subcarriers based on pilot symbols received from a base station.” Furthermore, Larsson is silent as to measuring interference based on pilot symbols received from a base station. As shown, the Examiner’s proposed combination fails to satisfy every claim limitation. Therefore, Appellant requests reversal of the rejection of record.

Claims 2, 12-14, 17, and 18 depend from claim 1 and claims 43, 46, and 47 depend from claim 30, respectively, and inherit every limitation of the claim from which they depend. As shown, the Examiner’s proposed combination fails to satisfy every limitation of claims 1 and 30. As such, claims 2, 12-14, 17, 18, 43, 46, and 47 set forth limitations not taught or suggested by the Examiner’s proposed combination and are patentable at least by virtue of their dependency on claims 1 and 30. In addition, these claims set forth limitations making them patentable in their own right.

For example, claim 12 recites “wherein the pilot symbols occupy an entire OFDM frequency bandwidth.” In the Current Action the Examiner points to Ritter, at page 3, lines 3-19, as satisfying this limitation. *See* Current Action, pg. 5. However, this citation merely describes background information regarding an OFDMA multi-carrier procedure which uses the OFDM Principle to transmit data symbols. However, Ritter is devoid of any suggestion of pilot symbols, much less pilot symbols that occupy an entire OFDM frequency bandwidth. It follows that Ritter does not satisfy pilot symbols occupying an entire OFDM frequency bandwidth, as set forth in the claim. Moreover, Larsson is not relied upon to satisfy this limitation, nor does it do so. As shown, the Examiner’s proposed combination fails to satisfy every claim limitation. Therefore, Appellant requests reversal of the rejection of record.

Similarly, claim 13 recites “ wherein at least one other pilot symbol from a different cell transmitted at the same time as the pilot symbols received from the base station collide with each other.” The Examiner relies on Ritter, at page 6, lines 19-23, as satisfying this limitation. Current Action, page 5. Additionally, the Examiner states that collision is a function of inter-cell interference. *Id.* Appellant initially notes, however, that Examiner fails to provide any support for his assertion. Moreover, as discussed above, Ritter does not even satisfy pilot symbols that occupy an entire OFDM frequency bandwidth. It follows that Ritter also fails to satisfy “at least one other pilot symbol from a different cell transmitted at

the same time as the pilot symbols received from the base station collide with each other,” as set forth in the claim. Moreover, Larsson is not relied upon to satisfy this limitation, nor does it do so. As shown, the Examiner’s proposed combination fails to satisfy every claim limitation. Therefore, Appellant requests reversal of the rejection of record.

Claim 14 recites “the base station selecting the subcarriers from the set of candidate subcarriers based on additional information available to the base station.” Claim 43 recites a similar limitation. The Examiner cites to Ritter, at page 5, line 11-page 6, line 6 and page 6, lines 19-23 as satisfying this limitation. *See* Current Action, page 5. In addition, the Examiner states in the Current Action that the inter-cell interference could be considered as additional information, and that the claimed subcarriers are considered as being the subset of the prior art segment frequency spectrum. *Id.* at page 6. Appellant respectfully disagrees with the Examiner’s characterization of Ritter regarding this limitation. First, the cited segments of Ritter discusses “control means in each base station to evaluate the information received from the mobile stations and to allocate a segment ...depending on the evaluation.” Clearly, this does not satisfy base station having access to additional information that it can use to perform the evaluation. Second, the cited passages also state “by means of the invention, the interferences, especially...inter-cell interference... and inter-symbol interferences, are considered and compensated for.” Even if it is conceded that inter-cell interference could be considered as additional information as the Examiner suggests, this does not satisfy the additional information is 1) available to the base station and 2) used by the base station in allocating radio resources to the mobile stations.

Furthermore, Ritter mentions the role of the base station in the mobile station assignment only one other time and simply states “the base station...evaluates all information received from the mobile stations...and assigns each mobile station a segment for the respective communication link depending on the evaluation.” Ritter, page 14, lines 9-12. It is evident that Ritter describes an evaluation process performed by the base station that consists of only the information provided by the mobile station and nothing else, no additional information is used in the process, and no additional information is available to the base station. Moreover, Larsson is not relied upon to satisfy this limitation, nor does it do so. As shown, the Examiner’s proposed combination fails to satisfy every claim limitation. Therefore, Appellant requests reversal of the rejection of record.

Claims 17 recites “wherein the indication of subcarriers is received via a downlink control channel.” Claim 46 recites a similar limitation. In the Current Action the Examiner points to Ritter, at page 5, line 5 – page 6, line 6; page 23, lines 8-19, as satisfying this limitation. *See* Current Action, page 6. As discussed above, Ritter mentions only the base station evaluating the information received from the mobile stations and allocating a segment to each mobile station based on the evaluation, and a transmission means in the base station to transmit information across the assigned segment to each mobile station. Ritter, page 5, line 5 – page 6, line 6. Although Ritter describes the transmitter means, MHF, to receive all subcarriers from the air in the down link direction (*Id.* at page 23, lines 8-9), there is no communication regarding the indication of subcarriers between the subscriber unit and the base station because the base station allocates the segment to each mobile station immediately once it has performed the evaluation process. Thus, Ritter does not satisfy the limitation of receipt of the indication of subcarriers, much less receiving the indication via a downlink control channel. Moreover, Larsson is not relied upon to satisfy this limitation, nor does it do so. As shown, the Examiner’s proposed combination fails to satisfy every claim limitation. Therefore, Appellant requests reversal of the rejection of record.

C. Third Ground of Rejection

Claims 3, 4, 19, 20, 23, 48, 49, and 52 are rejected under 35 U.S.C. § 103(a) as being unpatentable over the references applied to claim 1, and further in view of Yan.

In rejecting claims under 35 U.S.C. § 103, the Examiner bears the initial burden of establishing a prima facie case of obviousness. *In re Piasecki*, 745 F.2d 1468, 1472 (Fed. Cir. 1984). The Examiner can satisfy this burden by showing some articulated reasoning with some rational underpinning to support the legal conclusion of obviousness. *KSR Int’l. v. Teleflex Inc.*, 127 S. Ct 1727, 1741 (2007) (*citing In re Kahn*, 441 F.3d 977, 988 (Fed. Cir. 2006)). Only if this initial burden is met does the burden of coming forward with evidence or argument shift to the Appellant. *Piasecki*, 745 F.2d at 1472. Thus, the Examiner must not only assure that the requisite findings are made, based on evidence of record, but must also explain the reasoning by which the findings are deemed to support the Examiner’s conclusion. Without conceding Examiner explained the reasoning by which the findings are

deemed to support his conclusion, Appellant respectfully asserts that the Examiner's rejection fails to satisfy the requisite findings.

Claims 3, 4, 19, 20, and 23 depend from claim 1 and claims 48, 49, and 52 depend from claim 30, respectively, and inherit every limitation of the claim from which they depend. As shown above, Ritter does not satisfy every limitation of claims 1 and 30. Moreover, Yan is not relied upon to satisfy the missing limitations, nor does it do so. As such, claims 3, 4, 19, 20, 23, 48, 49, and 52 set forth limitations not satisfied by the Examiner's proposed combination and are patentable at least by virtue of their dependency from claims 1 and 30. In addition, these claims set forth limitations making them patentable in their own right.

For Example, claims 4 recites "the base station select[s] subcarriers for the subscriber unit based on inter-cell interference avoidance." The Examiner cites Ritter, at page 6, lines 19-23, as satisfying this limitation. *See Current Action*, page 7. The cited passages states "by means of the invention, the interferences, especially...inter-cell interference... and inter-symbol interferences, are considered and compensated for." As discussed above, there is nothing in this cited passage that suggests that the base station utilizes the inter-cell interference avoidance in allocating radio resources to the mobile stations. Instead, the cited portion merely states that interferences are considered and compensated for. However, Ritter does not disclose how interference is compensated for, much less that subcarriers are selected based on interference avoidance, as set forth in the claim. Moreover, Yan is not relied upon to satisfy this limitation, nor does it do so. As shown, the Examiner's proposed combination fails to satisfy every claim limitation. Therefore, Appellant requests reversal of the rejection of record.

Claims 19 recites "providing feedback information comprises arbitrarily ordering the set of candidate of subcarriers as clusters of subcarriers." Claim 48 recites a similar limitation. In the *Current Action*, the Examiner relies upon Ritter, at page 19, lines 11-16; claim 4, as satisfying "arbitrarily ordering the set of candidate of subcarrier." *See Current Action*, pg. 8. However, Ritter describes a priority list that the mobile station sends to the base station (page 19, lines 11-16; claim 4). Merriam-Webster's Collegiate Dictionary defines "priority" as something given or meriting attention before competing alternatives. It

follows that the definition of “priority” is not the equivalent of the definition of “arbitrary”. Clearly, Ritter teaches a priority list, which is not “arbitrarily ordering,” as required by the claims. Moreover, Yan is not relied upon to satisfy this limitation, nor does it do so. As shown, the Examiner’s proposed combination fails to satisfy every claim limitation. Therefore, Appellant requests reversal of the rejection of record.

D. Fourth Ground of Rejection

Claims 15, 16, 44, and 45 are rejected under 35 U.S.C. § 103(a) as being unpatentable over the references applied to the claims in the Third Ground of Rejection, and further in view of Westroos.

In rejecting claims under 35 U.S.C. § 103, the Examiner bears the initial burden of establishing a prima facie case of obviousness. *In re Piasecki*, 745 F.2d 1468, 1472 (Fed. Cir. 1984). The Examiner can satisfy this burden by showing some articulated reasoning with some rational underpinning to support the legal conclusion of obviousness. *KSR Int’l. v. Teleflex Inc.*, 127 S. Ct 1727, 1741 (2007) (citing *In re Kahn*, 441 F.3d 977, 988 (Fed. Cir. 2006)). Only if this initial burden is met does the burden of coming forward with evidence or argument shift to the Appellant. *Piasecki*, 745 F.2d at 1472. Thus, the Examiner must not only assure that the requisite findings are made, based on evidence of record, but must also explain the reasoning by which the findings are deemed to support the Examiner’s conclusion. Without conceding Examiner explained the reasoning by which the findings are deemed to support his conclusion, Appellant respectfully asserts that the Examiner’s rejection fails to satisfy the requisite findings.

Claims 15 and 16 depend from claim 1 and claims 44 and 45 depend from claim 30, respectively, and inherit every limitation of the claim from which they depend. As shown above, Ritter does not satisfy every limitation of claims 1 and 30. Moreover, Westroos is not relied upon to satisfy the missing limitations, nor does it do so. As such, claims 15, 16, 44, and 45 set forth limitations not satisfied by the Examiner’s proposed combination and are patentable at least by virtue of their dependency from claims 1 and 30. In addition, claims 15, 16, 44, and 45 set forth limitation making them patentable in their own right.

For example, claim 16 recites “wherein the traffic load information is provided by a data buffer in the base station.” Claim 45 recites a similar limitation. In the Current Action the Examiner relies upon Westroos, at col. 5 lines 45-65, as satisfying this limitation. However, Westroos merely describes assigning a traffic channel to a mobile station when a mobile station attempts to access a particular cell. The assignment may be a “load dependent traffic assignment.” But, Westroos does not describe what mechanism is used to make the traffic assignment, or even if the assignment is necessarily made at the base station. It follows that Westroos does not satisfy traffic information provided by a data buffer in the bases station, as set forth in the claim. Moreover, Ritter is not relied upon to satisfy this limitation, nor does it do so. As shown, the Examiner’s proposed combination fails to satisfy every claim limitation. Therefore, Appellant requests reversal of the rejection of record.

E. Fifth Ground of Rejection

Claims 29 and 62 are rejected under 35 U.S.C. § 103(a) as being unpatentable over Ritter in view of Yan and further in view of Feuerstein et al. (U.S. Patent No. 6,141,565) (hereinafter Feuerstein).

In rejecting claims under 35 U.S.C. § 103, the Examiner bears the initial burden of establishing a *prima facie* case of obviousness. *In re Piasecki*, 745 F.2d 1468, 1472 (Fed. Cir. 1984). The Examiner can satisfy this burden by showing some articulated reasoning with some rational underpinning to support the legal conclusion of obviousness. *KSR Int’l. v. Teleflex Inc.*, 127 S. Ct 1727, 1741 (2007) (citing *In re Kahn*, 441 F.3d 977, 988 (Fed. Cir. 2006)). Only if this initial burden is met does the burden of coming forward with evidence or argument shift to the Appellant. *Piasecki*, 745 F.2d at 1472. Thus, the Examiner must not only assure that the requisite findings are made, based on evidence of record, but must also explain the reasoning by which the findings are deemed to support the Examiner’s conclusion. Without conceding Examiner explained the reasoning by which the findings are deemed to support his conclusion, Appellant respectfully asserts that the Examiner’s rejection fails to satisfy the requisite findings.

Independent claims 29 and 62 recite “base station performing subcarrier allocation...based on inter-cell interference avoidance and intra-cell traffic load balancing.”

The Examiner cites Ritter, at page 6, line 19 – page 7, line 9, as satisfying “based on inter-cell interference avoidance.” *See* Current Action, page 7. However, as discussed above, the cited passages states “by means of the invention, the interferences, especially...inter-cell interference... and inter-symbol interferences, are considered and compensated for.” Nothing in the cited portion suggests the base station utilizes the inter-cell interference avoidance in allocating radio resources to the mobile stations. Instead, the cited portion merely states that interferences are considered and compensated for without disclosing how interference is compensated for, much less that subcarrier allocation is based on interference avoidance, as set forth in the claim. Moreover, Yan is not relied upon to satisfy this limitation, nor does it do so.

Furthermore, in the Current Action, at page 10, the Examiner acknowledges that Ritter does not satisfy subcarrier allocation based on intra-cell traffic load balancing. Instead, the Examiner points to Feuerstein, at col. 2, lines 27-37, as satisfying this limitation. *See* Current Action, pages 10-11. However, at the Examiner’s citation, Feuerstein describes changing network parameters according to “local interference and/or local traffic conditions” in order to optimize the network parameters. *See* Feuerstein at col. 2, lines 32-34. In discussing “local interference” Feuerstein contemplates traffic density distribution, etc. between cells. *Id.* at col. 2, lines 50-52. For example, according to Feuerstein, a mobile unit may request handoff based on the relative traffic loads between two cells. *Id.* at col. 6, lines 51-57. However, Appellant notes that merely evaluating relative traffic loads between two cells is not the same as allocating subcarriers based on traffic load balancing within a cell. Feuerstein does not contemplate evaluating load balancing within each cell. As such, Feuerstein does not satisfy performing subcarrier allocation based on intra-cell traffic load balancing, as set forth in the claim. As shown, the Examiner’s proposed combination fails to satisfy every claim limitation. Therefore, Appellant requests reversal of the rejection of record.

F. Sixth Ground of Rejection

Claims 58-61 are rejected under 35 U.S.C. § 103(a) as being unpatentable over Ritter in view of Frodigh

In rejecting claims under 35 U.S.C. § 103, the Examiner bears the initial burden of establishing a prima facie case of obviousness. *In re Piasecki*, 745 F.2d 1468, 1472 (Fed. Cir. 1984). The Examiner can satisfy this burden by showing some articulated reasoning with some rational underpinning to support the legal conclusion of obviousness. *KSR Int'l. v. Teleflex Inc.*, 127 S. Ct 1727, 1741 (2007) (citing *In re Kahn*, 441 F.3d 977, 988 (Fed. Cir. 2006)). Only if this initial burden is met does the burden of coming forward with evidence or argument shift to the Appellant. *Piasecki*, 745 F.2d at 1472. Thus, the Examiner must not only assure that the requisite findings are made, based on evidence of record, but must also explain the reasoning by which the findings are deemed to support the Examiner's conclusion. Without conceding Examiner explained the reasoning by which the findings are deemed to support his conclusion, Appellant respectfully asserts that the Examiner's rejection fails to satisfy the requisite findings.

Independent claim 58 recites "the base station allocating a second portion of said plurality of subcarriers to the subscriber unit to increase communication bandwidth." Independent claim 60 recites a similar limitation. In the Current Action the Examiner acknowledges that Ritter does not satisfy this limitation. *See* Current Action, pages 12-13. Instead, the Examiner relies upon Frodigh, at col. 4, lines 32-49, as satisfying this limitation. *Id.* at page 13. Generally, Frodigh "selectively chooses" a group of subcarriers to be adaptively allocated to avoid requiring that all OFDM subcarriers be adaptively allocated. *See* Frodigh at col. 4, lines 44-49. In doing so, the use of system resources is minimized. *Id.* As such, Frodigh merely describes minimizing the use of resources by adaptively allocating only a portion of (as opposed to all) subcarriers. In any event, Frodigh is silent as to how merely selecting a portion of available subcarriers will be used to affect communication between a base station and subscriber unit. As such, Frodigh falls short of disclosing allocating a second portion of subcarriers to increase communication bandwidth. As shown, the Examiner's proposed combination fails to satisfy every claim limitation. Therefore, Appellant requests reversal of the rejection of record.

Claim 59 depends from claim 58 and 61 depends from claim 60, respectively, and inherit every limitation of the claim from which they depend. As shown above, Ritter does not satisfy every limitation of claim 30. Moreover, Frodigh is not relied upon to satisfy the missing limitations, nor does it do so. As such, claims 59 and 61 set forth limitations not

satisfied by the Examiner's proposed combination and are patentable at least by virtue of their dependency from claim 30. Therefore, Appellant requests reversal of the rejection of record.

VIII. CLAIMS APPENDIX

A copy of the claims involved in the present appeal is attached hereto as Claims Appendix.

IX. EVIDENCE APPENDIX

No evidence pursuant to 37 C.F.R. §§ 1.130, 1.131, or 1.132 or entered by or relied upon by the Examiner is being submitted.

X. RELATED PROCEEDINGS APPENDIX

No related proceedings are referenced in II. above, hence copies of decisions in related proceedings are not provided.

Dated: October 9, 2007

Respectfully submitted,

I hereby certify that this paper (along with any paper referred to as being attached or enclosed) is being transmitted via the Office electronic filing system in accordance with § 1.6(a)(4).

Dated: October 9, 2007

Signature: Donna Dobson
Donna Dobson

By Robert Greeson
Robert L. Greeson
Registration No.: 52,966
FULBRIGHT & JAWORSKI L.L.P.
2200 Ross Avenue, Suite 2800
Dallas, Texas 75201-2784
(214) 855-8000
(214) 855-8200 (Fax)
Attorney for Applicant

CLAIMS APPENDIX**Claims Involved in the Appeal of Application Serial No. 11/199,586**

1. A method for subcarrier selection for a system employing orthogonal frequency division multiple access (OFDMA) comprising:
 - a subscriber unit measuring channel and interference information for a plurality of subcarriers based on pilot symbols received from a base station;
 - the subscriber unit selecting a set of candidate subcarriers;
 - the subscriber unit providing feedback information on the set of candidate subcarriers to the base station; and
 - the subscriber unit receiving an indication of subcarriers of the set of subcarriers selected by the base station for use by the subscriber unit.
2. The method defined in Claim 1 further comprising the subscriber unit sending the indication to the base station.
3. The method defined in Claim 2 further comprising sending an indication of the group of clusters selected by the base station for use by the subscriber unit.
4. The method defined in Claim 3 further comprising the base station selecting subcarriers for the subscriber unit based on inter-cell interference avoidance.
- 5.-6. (Canceled)
7. The method defined in Claim 1 further comprising the subscriber unit submitting new feedback information after being allocated the set of subscriber units to be allocated a new set of subcarriers and thereafter the subscriber unit receiving another indication of the new set of subcarriers.
8. The method defined in Claim 1 further comprising the subscriber unit using information from pilot symbol periods and data periods to measure channel and interference information.

9.-11. (Canceled)

12. The method defined in Claim 1 wherein the pilot symbols occupy an entire OFDM frequency bandwidth.

13. The method defined in Claim 12 wherein at least one other pilot symbol from a different cell transmitted at the same time as the pilot symbols received from the base station collide with each other.

14. The method defined in Claim 1 further comprising the base station selecting the subcarriers from the set of candidate subcarriers based on additional information available to the base station.

15. The method defined in Claim 14 wherein the additional information comprises traffic load information on each cluster of subcarriers.

16. The method defined in Claim 15 wherein the traffic load information is provided by a data buffer in the base station.

17. The method defined in Claim 1 wherein the indication of subcarriers is received via a downlink control channel.

18. The method defined in Claim 1 wherein the plurality of subcarriers comprises all subcarriers allocable by a base station.

19. The method defined in Claim 1 wherein providing feedback information comprises arbitrarily ordering the set of candidate of subcarriers as clusters of subcarriers.

20. The method defined in Claim 19 wherein arbitrarily order candidate clusters comprise clusters in an order with most desirable candidate clusters being listed first.

21.-22. (Canceled)

23. The method defined in Claim 1 wherein providing feedback information comprises sequentially ordering candidate clusters.

24.-25. (Canceled)

26. The method defined in Claim 1 further comprising:

the base station allocating a first portion of the subcarriers to establish a data link between the base station and the subscriber unit; and then

the base station allocating a second portion of the subcarriers to the subscriber unit to increase communication bandwidth.

27. The method defined in Claim 26 wherein the base station allocates the second portion after allocating each subscriber unit in the cell subcarriers to establish a data link between the base station and said each subscriber unit.

28. (Canceled)

29. An apparatus comprising:

a plurality of subscriber units in a first cell to generate feedback information indicating clusters of subcarriers desired for use by the plurality of subscriber units; and

a first base station in the first cell, the first base station performing subcarrier allocation for OFDMA to allocate OFDMA subcarriers in clusters to the plurality of subscriber units based on inter-cell interference avoidance and intra-cell traffic load balancing in response to the feedback information.

30. An apparatus comprising:

a plurality of subscriber units in a first cell operable to generate feedback information indicating clusters of subcarriers desired for use by the plurality of subscriber units; and

a first base station in the first cell, the first base station operable to allocate OFDMA subcarriers in clusters to the plurality of subscriber units;

each of said plurality of subscriber units to measure channel and interference information for the plurality of subcarriers based on pilot symbols received from the first base station and at least one of the plurality of subscriber units to select a set of candidate subcarriers from the plurality of subcarriers, and said at least one subscriber unit to provide feedback information on the set of candidate subcarriers to the base station and to receive an indication of subcarriers from the set of subcarriers selected by the first base station for use by the at least one subscriber unit.

31. The apparatus defined in Claim 30 wherein each of the plurality of subscriber units continuously monitors reception of the pilot symbols known to the base station and the plurality of subscriber units and measures signal-plus-interference-to-noise ratio (SINR) of each cluster of subcarriers.

32. The apparatus defined in Claim 31 wherein each of the plurality of subscriber units measures inter-cell interference, wherein the at least one subscriber unit selects candidate subcarriers based on the inter-cell interference.

33. The apparatus defined in Claim 32 wherein the base station selects subcarriers for the one subscriber unit based on inter-cell interference avoidance.

34.-35. (Canceled)

36. The apparatus defined in Claim 30 wherein the subscriber unit submits new feedback information after being allocated the set of subscriber units to receive a new set of subcarriers and thereafter receives another indication of the new set of subcarriers.

37. The apparatus defined in Claim 30 wherein the at least one subscriber unit uses information from pilot symbol periods and data periods to measure channel and interference information.

38.-42. (Canceled)

43. The apparatus defined in Claim 30 wherein the base station selects the subcarriers from the set of candidate subcarriers based on additional information available to the base station.

44. The apparatus defined in Claim 43 wherein the additional information comprises traffic load information on each cluster of subcarriers.

45. The apparatus defined in Claim 44 wherein the traffic load information is provided by a data buffer in the base station.

46. The apparatus defined in Claim 30 wherein the indication of subcarriers is received via a downlink control channel between the base station and the at least one subscriber unit.

47. The apparatus defined in Claim 30 wherein the plurality of subcarriers comprises all subcarriers allocable by a base station.

48. The apparatus defined in Claim 30 wherein the plurality of subscriber units provide feedback information that comprises an arbitrarily ordered set of candidate subcarriers as clusters of subcarriers.

49. The apparatus defined in Claim 48 wherein arbitrarily order candidate clusters comprise clusters in an order with most desirable candidate clusters being listed first.

50.-51. (Canceled)

52. The apparatus defined in Claim 30 wherein providing feedback information comprises sequentially ordering candidate clusters.

53.-54. (Canceled)

55. The apparatus defined in Claim 30 wherein the base station allocates a first portion of the subcarriers to establish a data link between the base station and the subscriber unit; and then allocates a second portion of the subcarriers to the subscriber unit to increase communication bandwidth.

56. The apparatus defined in Claim 55 wherein the base station allocates the second portion after allocating each subscriber unit in the cell subcarriers to establish a data link between the base station and said each subscriber unit.

57. (Canceled)

58. A method comprising:
a base station allocating a first portion of a plurality of subcarriers to establish a data link between the base station and a subscriber unit; and

the base station allocating a second portion of said plurality of subcarriers to the subscriber unit to increase communication bandwidth.

59. The method defined in Claim 57 wherein the base station allocates the second portion after allocating each subscriber unit in the cell subcarriers to establish a data link between the base station and said each subscriber unit.

60. A base station comprising:

means for allocating a first portion of a plurality of subcarriers to establish a data link between the base station and a subscriber unit; and

means for allocating a second portion of said plurality of subcarriers to the subscriber unit to increase communication bandwidth.

61. The apparatus defined in Claim 60 wherein the base station allocates the second portion after allocating each subscriber unit in the cell subcarriers to establish a data link between the base station and said each subscriber unit.

62. An apparatus comprising:

a plurality of subscriber units in a cell; and

a base station in the cell, the base station to perform subcarrier allocation for OFDMA to allocate OFDMA subcarriers in clusters to the plurality of subscriber units based on inter-cell interference avoidance and intra-cell traffic load balancing.

EVIDENCE APPENDIX

None

RELATED PROCEEDINGS APPENDIX

None

Electronic Patent Application Fee Transmittal

Application Number:	11199586			
Filing Date:	08-Aug-2005			
Title of Invention:	OFDMA with adaptive subcarrier-cluster configuration and selective loading			
First Named Inventor/Applicant Name:	Xiaodong Li			
Filer:	David H. Tannenbaum/Donna Dobson			
Attorney Docket Number:	68144/P014C1/10503148			
Filed as Small Entity				
Utility Filing Fees				
Description	Fee Code	Quantity	Amount	Sub-Total in USD(\$)
Basic Filing:				
Pages:				
Claims:				
Miscellaneous-Filing:				
Petition:				
Patent-Appeals-and-Interference:				
Filing a brief in support of an appeal	2402	1	255	255
Post-Allowance-and-Post-Issuance:				
Extension-of-Time:				

Description	Fee Code	Quantity	Amount	Sub-Total in USD(\$)
Miscellaneous:				
Total in USD (\$)				255

Electronic Acknowledgement Receipt

EFS ID:	2297349
Application Number:	11199586
International Application Number:	
Confirmation Number:	1128
Title of Invention:	OFDMA with adaptive subcarrier-cluster configuration and selective loading
First Named Inventor/Applicant Name:	Xiaodong Li
Customer Number:	29053
Filer:	David H. Tannenbaum/Donna Dobson
Filer Authorized By:	David H. Tannenbaum
Attorney Docket Number:	68144/P014C1/10503148
Receipt Date:	09-OCT-2007
Filing Date:	08-AUG-2005
Time Stamp:	17:13:12
Application Type:	Utility under 35 USC 111(a)

Payment information:

Submitted with Payment	yes
Payment was successfully received in RAM	\$255
RAM confirmation Number	2318
Deposit Account	

File Listing:

Document Number	Document Description	File Name	File Size(Bytes) /Message Digest	Multi Part /.zip	Pages (if appl.)
-----------------	----------------------	-----------	-------------------------------------	------------------	------------------

1		P014C1.pdf	915521	yes	30
			a6904e3d6fcc90b3c51fd6e98b017a49 54f07ff4		
Multipart Description/PDF files in .zip description					
		Document Description	Start	End	
		Notice of Appeal Filed	1	1	
		Miscellaneous Incoming Letter	2	2	
		Appeal Brief Filed	3	30	
Warnings:					
Information:					
2	Fee Worksheet (PTO-06)	fee-info.pdf	8195	no	2
			ctc41d3aeb4dfe4f415ce7e361106e785 3b81975		
Warnings:					
Information:					
Total Files Size (in bytes):			923716		
<p>This Acknowledgement Receipt evidences receipt on the noted date by the USPTO of the indicated documents, characterized by the applicant, and including page counts, where applicable. It serves as evidence of receipt similar to a Post Card, as described in MPEP 503.</p> <p><u>New Applications Under 35 U.S.C. 111</u> If a new application is being filed and the application includes the necessary components for a filing date (see 37 CFR 1.53(b)-(d) and MPEP 506), a Filing Receipt (37 CFR 1.54) will be issued in due course and the date shown on this Acknowledgement Receipt will establish the filing date of the application.</p> <p><u>National Stage of an International Application under 35 U.S.C. 371</u> If a timely submission to enter the national stage of an international application is compliant with the conditions of 35 U.S.C. 371 and other applicable requirements a Form PCT/DO/EO/903 indicating acceptance of the application as a national stage submission under 35 U.S.C. 371 will be issued in addition to the Filing Receipt, in due course.</p> <p><u>New International Application Filed with the USPTO as a Receiving Office</u> If a new international application is being filed and the international application includes the necessary components for an international filing date (see PCT Article 11 and MPEP 1810), a Notification of the International Application Number and of the International Filing Date (Form PCT/RO/105) will be issued in due course, subject to prescriptions concerning national security, and the date shown on this Acknowledgement Receipt will establish the international filing date of the application.</p>					

Under the Paperwork Reduction Act of 1995, no persons are required to respond to a collection of information unless it displays a valid OMB control number

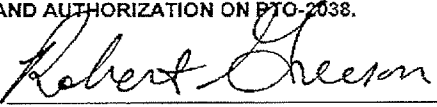
NOTICE OF APPEAL FROM THE EXAMINER TO THE BOARD OF PATENT APPEALS AND INTERFERENCES		Docket Number (Optional) 68144/P014C1/10503148	
In re Application of Xiaodong Li et al.			
Application Number 11/199,586-Conf. #1128	Filed August 8, 2005		
For OFDMA WITH ADAPTIVE SUBCARRIER-CLUSTER CONFIGURATION AND SELECTIVE LOADING			
Art Unit 2617	Examiner M. N. Zewdu		
Applicant hereby appeals to the Board of Patent Appeals and Interferences from the last decision of the examiner.			
The fee for this Notice of Appeal is (37 CFR 41.20(b)(1))		\$ -0-	
<input type="checkbox"/> Applicant claims small entity status. See 37 CFR 1.27. Therefore, the fee shown above is reduced by half, and the resulting fee is:		\$	
<input type="checkbox"/> A check in the amount of the fee is enclosed.			
<input type="checkbox"/> Payment by credit card.			
<input type="checkbox"/> The Director has already been authorized to charge fees in this application to a Deposit Account. I have enclosed a duplicate copy of this sheet.			
<input checked="" type="checkbox"/> The Director is hereby authorized to charge any fees which may be required, or credit any overpayment to Deposit Account No. <u>06-2380</u> .			
<input type="checkbox"/> A petition for an extension of time under 37 CFR 1.136(a) (PTO/SB/22) is enclosed.			
WARNING: INFORMATION ON THIS FORM MAY BECOME PUBLIC. CREDIT CARD INFORMATION SHOULD NOT BE INCLUDED ON THIS FORM. PROVIDE CREDIT CARD INFORMATION AND AUTHORIZATION ON PTO-2038.			
I am the		 Signature Robert L. Greeson Typed or printed name (214) 855-7430 Telephone number October 9, 2007 Date	
<input type="checkbox"/> applicant /inventor.			
<input type="checkbox"/> assignee of record of the entire interest. See 37 CFR 3.71. Statement under 37 CFR 3.73(b) is enclosed. (Form PTO/SB/96)			
<input checked="" type="checkbox"/> attorney or agent of record. Registration number <u>52,966</u>			
<input type="checkbox"/> attorney or agent acting under 37 CFR 1.34. Registration number if acting under 37 CFR 1.34. _____			
NOTE: Signatures of all the inventors or assignees of record of the entire interest or their representative(s) are required. Submit multiple forms if more than one signature is required, see below*.			

<input type="checkbox"/> *Total of <u>1</u> forms are submitted.
--

TRANSMITTAL OF APPEAL BRIEF

Docket No.
68144/P014C1/10503148

In re Application of: Xiaodong Li et al.

Application No.
11/199,586-Conf. #1128

Filing Date
August 8, 2005

Examiner
M. N. Zewdu

Group Art Unit
2617

Invention: OFDMA WITH ADAPTIVE SUBCARRIER-CLUSTER CONFIGURATION AND SELECTIVE LOADING

TO THE COMMISSIONER OF PATENTS:

Transmitted herewith is the Appeal Brief in this application, with respect to the Notice of Appeal filed: October 9, 2007

The fee for filing this Appeal Brief is \$ 255.00

Large Entity Small Entity

A petition for extension of time is also enclosed.

The fee for the extension of time is _____

A check in the amount of _____ is enclosed.

Charge the amount of the fee to Deposit Account No. _____

Payment by credit card.

The Director is hereby authorized to charge any additional fees that may be required or credit any overpayment to Deposit Account No. 06-2380



Dated: October 9, 2007

Robert L. Greeson
Attorney Reg. No. : 52,966
FULBRIGHT & JAWORSKI L.L.P.
2200 Ross Avenue, Suite 2800
Dallas, Texas 75201-2784
(214) 855-7430

Sun, 30 Dec 2007, 11:22:22 AM EST

Edit an existing query or compose a new query in the Search Query Display.

Search Query Display



Select a search number (#) to:

- Add a query to the Search Query Display
- Combine search queries using AND, OR, or NOT
- Delete a search
- Run a search

Recent Search Queries

- #1 (((allocation or assignment or selection) and (subchannel or subcarrier or subband) and (reporting or feedback)))<in>metadata
- #2 (((allocation or assignment or selection) and (subchannel or subcarrier or subband) and (reporting or feedback)))<in>metadata
- #3 (((allocation or assignment or selection) and (subchannel or subcarrier or subband) and (reporting or feedback)))<in>metadata
- #4 (((allocation or assignment or selection) and (subchannel or subcarrier or subband) and (reporting or feedback)))<in>metadata
- #5 (((allocation or assignment or selection) and (subchannel or subcarrier or subband) and (reporting or feedback)))<in>metadata
- #6 (((allocation or assignment or selection) and (subchannel or subcarrier or subband) and (reporting or feedback)))<in>metadata
- #7 (((adaptive or dynamic) and (subchannel or subband or subcarrier or slot) and (allocation or assignment or selection) and (ofdma or ofdm)))<in>metadata
- #8 (((adaptive or dynamic) and (subchannel or subband or subcarrier or slot) and (allocation or assignment or selection) and (ofdma or ofdm)))<in>metadata
- #9 (((adaptive or dynamic) and (subchannel or subband or subcarrier or slot) and (allocation or assignment or selection) and (ofdma or ofdm)))<in>metadata
- #10 (((adaptive or dynamic) and (subchannel or subband or subcarrier or slot) and (allocation or assignment or selection) and (ofdma or ofdm)))<in>metadata
- #11 (((adaptive or dynamic) and (subchannel or subband or subcarrier or slot) and (allocation or assignment or selection) and (ofdma or ofdm)))<in>metadata
- #12 (((adaptive or dynamic) and (subchannel or subband or subcarrier or slot) and (allocation or assignment or selection) and (ofdma or ofdm)))<in>metadata

and (ofdma or ofdm)))<in>metadata)

#13 (((adaptive or dynamic) and (subchannel or subband or subcarrier or slot) and (allocation or assignment or selection) and (ofdma or ofdm)))<in>metadata)



[Help](#) [Contact Us](#) [Privacy &](#)

© Copyright 2007 IEEE -

Indexed by
 Inspect[®]

[Search Session History](#)

[BROWSE](#)

[SEARCH](#)

[IEEE XPLORE GUIDE](#)

Sun, 30 Dec 2007, 12:10:20 PM EST

Edit an existing query or compose a new query in the Search Query Display.

Search Query Display

Select a search number (#) to:

- Add a query to the Search Query Display
- Combine search queries using AND, OR, or NOT
- Delete a search
- Run a search

Recent Search Queries

- #1 (((subscriber or user) and (increasing or adding or additional) and (bandwidth or subband or subchannel or subcarrier)))
<in>metadata)

- #2 (((subscriber or user) and (increasing or adding or additional) and (bandwidth or subband or subchannel or subcarrier)) and (ofdma or ofdm))<in>metadata)

- #3 (((subscriber or user) and (increasing or adding or additional) and (bandwidth or subband or subchannel or subcarrier)) and (ofdma or ofdm))<in>metadata)

- #4 (((subscriber or user) and (increasing or adding or additional) and (bandwidth or subband or subchannel or subcarrier)) and (ofdma or ofdm))<in>metadata)

- #5 (((subscriber or user) and (increasing or adding or additional) and (bandwidth or subband or subchannel or subcarrier)))
<in>metadata)

[Help](#) [Contact Us](#) [Privacy &](#)

© Copyright 2007 IEEE -

Indexed by
 Inspec

Notice of References Cited

Application/Control No. 11/199,586	Applicant(s)/Patent Under Reexamination LI ET AL.	
Examiner Meless N. Zewdu	Art Unit 2617	Page 1 of 1

U.S. PATENT DOCUMENTS

*		Document Number Country Code-Number-Kind Code	Date MM-YYYY	Name	Classification
*	A	US-6,052,594	04-2000	Chuang et al.	455/450
*	B	US-6,526,281 B1	02-2003	Gorsuch et al.	455/452.1
*	C	US-6,985,432 B1	01-2006	Hadad, Zion	370/203
	D	US-			
	E	US-			
	F	US-			
	G	US-			
	H	US-			
	I	US-			
	J	US-			
	K	US-			
	L	US-			
	M	US-			

FOREIGN PATENT DOCUMENTS

*		Document Number Country Code-Number-Kind Code	Date MM-YYYY	Country	Name	Classification
	N					
	O					
	P					
	Q					
	R					
	S					
	T					

NON-PATENT DOCUMENTS

*		Include as applicable: Author, Title Date, Publisher, Edition or Volume, Pertinent Pages)
	U	
	V	
	W	
	X	

*A copy of this reference is not being furnished with this Office action. (See MPEP § 707.05(a).) Dates in MM-YYYY format are publication dates. Classifications may be US or foreign.

Index of Claims



Application/Control No.

11/199,586

Examiner

Meless N. Zewdu

Applicant(s)/Patent under Reexamination

LI ET AL.

Art Unit

2617

√	Rejected
=	Allowed

—	(Through numeral) Cancelled
÷	Restricted

N	Non-Elected
I	Interference

A	Appeal
O	Objected

Claim		Date									
Final	Original	12/31/07									
	1	√									
	2	√									
	3	√									
	4	√									
	5	-									
	6	-									
	7	O									
	8	√									
	9	-									
	10	-									
	11	-									
	12	√									
	13	√									
	14	√									
	15	√									
	16	√									
	17	√									
	18	√									
	19	√									
	20	√									
	21	-									
	22	-									
	23	√									
	24	-									
	25	-									
	26	O									
	27	O									
	28	-									
	29	√									
	30	√									
	31	√									
	32	O									
	33	O									
	34	-									
	35	-									
	36	O									
	37	√									
	38	-									
	39	-									
	40	-									
	41	-									
	42	-									
	43	√									
	44	√									
	45	√									
	46	√									
	47	√									
	48	-									
	49	√									
	50	-									

Claim		Date									
Final	Original	12/31/07									
	51	-									
	52	√									
	53	-									
	54	-									
	55	O									
	56	O									
	57	-									
	58	-									
	59	O									
	60	√									
	61	O									
	62	√									
	63										
	64										
	65										
	66										
	67										
	68										
	69										
	70										
	71										
	72										
	73										
	74										
	75										
	76										
	77										
	78										
	79										
	80										
	81										
	82										
	83										
	84										
	85										
	86										
	87										
	88										
	89										
	90										
	91										
	92										
	93										
	94										
	95										
	96										
	97										
	98										
	99										
	100										

Claim		Date									
Final	Original										
	101										
	102										
	103										
	104										
	105										
	106										
	107										
	108										
	109										
	110										
	111										
	112										
	113										
	114										
	115										
	116										
	117										
	118										
	119										
	120										
	121										
	122										
	123										
	124										
	125										
	126										
	127										
	128										
	129										
	130										
	131										
	132										
	133										
	134										
	135										
	136										
	137										
	138										
	139										
	140										
	141										
	142										
	143										
	144										
	145										
	146										
	147										
	148										
	149										
	150										



UNITED STATES PATENT AND TRADEMARK OFFICE

UNITED STATES DEPARTMENT OF COMMERCE
United States Patent and Trademark Office
Address: COMMISSIONER FOR PATENTS
P.O. Box 1450
Alexandria, Virginia 22313-1450
www.uspto.gov

APPLICATION NO.	FILING DATE	FIRST NAMED INVENTOR	ATTORNEY DOCKET NO.	CONFIRMATION NO.
11/199,586	08/08/2005	Xiaodong Li	68144/P014C1/I0503148	1128

29053 7590 01/10/2008
FULBRIGHT & JAWORSKI L.L.P
2200 ROSS AVENUE
SUITE 2800
DALLAS, TX 75201-2784

EXAMINER

ZEWDU, MELESS NMN

ART UNIT	PAPER NUMBER
2617	

MAIL DATE	DELIVERY MODE
01/10/2008	PAPER

Please find below and/or attached an Office communication concerning this application or proceeding.

The time period for reply, if any, is set in the attached communication.

Office Action Summary

Application No.

11/199,586

Applicant(s)

LI ET AL.

Examiner

Meless N. Zewdu

Art Unit

2617

-- The MAILING DATE of this communication appears on the cover sheet with the correspondence address --

Period for Reply

A SHORTENED STATUTORY PERIOD FOR REPLY IS SET TO EXPIRE 3 MONTH(S) OR THIRTY (30) DAYS, WHICHEVER IS LONGER, FROM THE MAILING DATE OF THIS COMMUNICATION.

- Extensions of time may be available under the provisions of 37 CFR 1.136(a). In no event, however, may a reply be timely filed after SIX (6) MONTHS from the mailing date of this communication.
- If NO period for reply is specified above, the maximum statutory period will apply and will expire SIX (6) MONTHS from the mailing date of this communication.
- Failure to reply within the set or extended period for reply will, by statute, cause the application to become ABANDONED (35 U.S.C. § 133). Any reply received by the Office later than three months after the mailing date of this communication, even if timely filed, may reduce any earned patent term adjustment. See 37 CFR 1.704(b).

Status

- 1) Responsive to communication(s) filed on 09 October 2007.
- 2a) This action is FINAL. 2b) This action is non-final.
- 3) Since this application is in condition for allowance except for formal matters, prosecution as to the merits is closed in accordance with the practice under *Ex parte Quayle*, 1935 C.D. 11, 453 O.G. 213.

Disposition of Claims

- 4) Claim(s) 1-4, 7, 8, 12-20, 23, 26, 27, 29-33, 36, 37, 43-49, 52, 55, 56 and 58-61 is/are pending in the application.
- 4a) Of the above claim(s) _____ is/are withdrawn from consideration.
- 5) Claim(s) _____ is/are allowed.
- 6) Claim(s) 1-4, 8, 12-20, 23, 29-31, 37, 43-49 and 52 is/are rejected.
- 7) Claim(s) 7, 26, 27, 32, 33, 36, 55, 56, 59 and 61 is/are objected to.
- 8) Claim(s) _____ are subject to restriction and/or election requirement.

Application Papers

- 9) The specification is objected to by the Examiner.
- 10) The drawing(s) filed on _____ is/are: a) accepted or b) objected to by the Examiner.
Applicant may not request that any objection to the drawing(s) be held in abeyance. See 37 CFR 1.85(a).
Replacement drawing sheet(s) including the correction is required if the drawing(s) is objected to. See 37 CFR 1.121(d).
- 11) The oath or declaration is objected to by the Examiner. Note the attached Office Action or form PTO-152.

Priority under 35 U.S.C. § 119

- 12) Acknowledgment is made of a claim for foreign priority under 35 U.S.C. § 119(a)-(d) or (f).
- a) All b) Some * c) None of:
- Certified copies of the priority documents have been received.
 - Certified copies of the priority documents have been received in Application No. _____.
 - Copies of the certified copies of the priority documents have been received in this National Stage application from the International Bureau (PCT Rule 17.2(a)).

* See the attached detailed Office action for a list of the certified copies not received.

Attachment(s)

- 1) Notice of References Cited (PTO-892)
- 2) Notice of Draftsperson's Patent Drawing Review (PTO-948)
- 3) Information Disclosure Statement(s) (PTO/SB/08)
Paper No(s)/Mail Date _____.
- 4) Interview Summary (PTO-413)
Paper No(s)/Mail Date. _____.
- 5) Notice of Informal Patent Application
- 6) Other: _____.

DETAILED ACTION

1. This action is in response to the communication filed on 10/9/07.
2. Claims 5-6, 9-11, 21-22, 24-25, 28, 34-35, 38-42, 50-51, 53-54 and 57 were previously canceled.
3. Claims 1-4, 7-8, 12-20, 23, 26-27, 29-33, 36-37, 43-49, 52, 55-56 and 58-62 are pending in this action.
4. Applicant's request for reconsideration of the finality of the rejection of the last Office action is persuasive and, therefore, the finality of that action is withdrawn.

Claim Objections

Claim 7 is objected to because of the following informalities: "the set of subscriber units", in lines 2-3 should be changed into --- the set of sub-carriers ---. Appropriate correction is required.

Claim 19 is objected to because of the following informalities: "candidate of sub-carriers" in line 2 should be modified into – candidate sub-carriers ---. Appropriate correction is required.

Claim 59 is objected to because of the following informalities: the claim has been made dependant on a canceled claim 57. For examination purpose, examiner considered claim 59 as depending on claim 58. Appropriate correction is required.

Claim 49 is objected to because of the following informalities: examiner need clarification on how an "**arbitrarily ordered candidate clusters comprise clusters in an order with most desirable candidate clusters being listed first**". Appropriate correction is required.

Claim Rejections - 35 USC § 112

The following is a quotation of the second paragraph of 35 U.S.C. 112:

The specification shall conclude with one or more claims particularly pointing out and distinctly claiming the subject matter which the applicant regards as his invention.

Claim 3 recites the limitation "the group of clusters" in line 2. There is insufficient antecedent basis for this limitation in the claim.

Double Patenting

The nonstatutory double patenting rejection is based on a judicially created doctrine grounded in public policy (a policy reflected in the statute) so as to prevent the unjustified or improper timewise extension of the "right to exclude" granted by a patent and to prevent possible harassment by multiple assignees. A nonstatutory obviousness-type double patenting rejection is appropriate where the conflicting claims are not identical, but at least one examined application claim is not patentably distinct from the reference claim(s) because the examined application claim is either anticipated by, or would have been obvious over, the reference claim(s). See, e.g., *In re Berg*, 140 F.3d 1428, 46 USPQ2d 1226 (Fed. Cir. 1998); *In re Goodman*, 11 F.3d 1046, 29 USPQ2d 2010 (Fed. Cir. 1993); *In re Longi*, 759 F.2d 887, 225 USPQ 645 (Fed. Cir. 1985); *In re Van Ornum*, 686 F.2d 937, 214 USPQ 761 (CCPA 1982); *In re Vogel*, 422 F.2d 438, 164 USPQ 619 (CCPA 1970); and *In re Thorington*, 418 F.2d 528, 163 USPQ 644 (CCPA 1969).

A timely filed terminal disclaimer in compliance with 37 CFR 1.321(c) or 1.321(d) may be used to overcome an actual or provisional rejection based on a nonstatutory double patenting ground provided the conflicting application or patent either is shown to be commonly owned with this application, or claims an invention made as a result of activities undertaken within the scope of a joint research agreement.

Effective January 1, 1994, a registered attorney or agent of record may sign a terminal disclaimer. A terminal disclaimer signed by the assignee must fully comply with 37 CFR 3.73(b).

Claims 1-4, 7-8, 12-15, 17-20, 22, 26-27, 29-33, 36-37, 43-49, 52, 55-56 and 58-62 are rejected on the ground of nonstatutory obviousness-type double patenting as being unpatentable over claims 1-23 of U.S. Patent No. 6,947,748 B2. Although the conflicting claims are not identical, they are not patentably distinct from each other because the difference between the claims in the instant application and claims in the patent is that the claims in the instant application are broader than the claims in the patent. For example, consider the following.

Claims 1-3 in the application read on at least claim 1 in the patent.

Claims 29 in the application reads on claims 12 and 16 in the patent.

Claims 7, 30, 36, 31 and 61 in the application read on claim 23 in the patent. In the case of claims 7 and 36, the new feedback information could be associated with a new request, i.e., when the subscriber access the base station a second time.

Claims 4, 32 and 33 in the application read on claims 2 and 16 in the patent.

Claims 8 and 37 in the application read on claim 5 in the patent.

Claim 12 in the application reads on claim 17 in the patent.

Claims 13 in the application reads on claim 18 in the patent.

Claims 14-15 and 43-44 in the application read on claims 12-13 and 16, wherein the traffic-load information could be interpreted as an additional information to the channel and interference information recited in claim 1 (in the application).

Claims 16 and 45 in the application read on claims 12-13 in the patent. In claims 12-13, particularly in claim 13, it is described that base station balances intra-cell traffic load. Hence, the base station must inherently have a buffer or an equivalent memory to store the traffic-load data.

Claim 17 in the application reads on claim 5 of the patent. An 'indication' is a control signal that must be transmitted via a control channel and a 'downlink' is a transmitting direction from a base station to a mobile station, all of which are discernable from claim 5 of the patent.

Claims 18 and 47 in the application read on claim 17 in the patent.

Claims 19, 20, 23, 46, 48, 49 and 52 in the application read on claims 6 and 19 in the patent. Orderly list in claim 20 and sequential order in claims 23 and 52 (in the application) reads on indexing in claims 6 and 19 in the patent.

Claims 26, 58 and 60 in the patent read on claim 10 of the patent.

Claims 27 and 56 in the application read on claim 10 of the patent.

Claims 29 and 62 in the application read on claim 11 of the patent.

Claims 55 and 59 in the application read on claims 10-12, 14, 19, 21 and 23 of the patent. In the indicated claims of the patent, it is shown that the base station allocates sub-carriers to a plurality of subscribers in a cell. In claims 10 and 23, it is indicated that a particular subscriber is allocated with a first and second portions of sub-carriers due to a priority. In the final analysis, the scope of the claims in the issued patent covers the entire scope of the claims in the instant application. The difference

between the claims in the instant application and the claims in the patent is that the claims in the instant application are broader than the claims in the patent.

Claim Rejections - 35 USC § 102

The following is a quotation of the appropriate paragraphs of 35 U.S.C. 102 that form the basis for the rejections under this section made in this Office action:

A person shall be entitled to a patent unless –

(b) the invention was patented or described in a printed publication in this or a foreign country or in public use or on sale in this country, more than one year prior to the date of application for patent in the United States.

Claims 1-4, 8, 12-18, 30-31, 37 and 43-47 are rejected under 35 U.S.C. 102(b) as being anticipated by Ritter (DE 19800953).

As per claim 1: while **OFDMA** in claim 1 is considered as an intended use (for lacking to enhance the body of the claims), Ritter discloses a method for sub-carrier selection for a system employing orthogonal frequency division multiple access (OFDMA) (see fig. in page 2), comprising:

a subscriber unit measuring channel and interference information (see page 6, lines 19-23) for a plurality of sub-carriers (page 5, lines 11-19) based on pilot symbols received from a base station (see page 7, lines 1-9; page 12, lines 12-17);

the subscriber unit selecting a set of candidate sub-carriers (see page 5, line 11- page 6, line 6). The prior art shows a subscriber selecting a suitable segment (sub-carriers). It is to be noted, that selection requires candidacy (in this case candidate sub-carrier selection).

the subscriber unit providing feedback information on the set of candidate sub-carriers to the base station (see page 5, lines 16-21);

the subscriber unit receiving an indication of sub-carriers of the set of sub-carriers selected by the base station for use by the subscriber (see page 5, line 22-page 6, line 6).

As per claim 2: Ritter teaches a method further comprising the subscriber unit sending the indication to the base station (see page 5, lines 16-21).

As per claim 3: Ritter discloses a method, further comprising sending an indication of the group cluster (sub-carriers) unit (see page 5, line 11-page 6, line 23).

As per claim 4: Ritter discloses a method, further comprising the base station selecting sub-carriers for the subscriber unit based on inter-cell interference avoidance (inter-cell consideration) (see page 6, lines 7-23).

As per claim 8: Ritter teaches a method, further comprising the subscriber unit using information from pilot periods and data to measure channel and interference information (see page 2, line 9-page 4, line 2; claim 11).

As per claim 12: Ritter teaches a method wherein the pilot symbols occupy an entire OFDM frequency bandwidth (see page 3, lines 9-19; page 6, lines 7-23; claim 1).

As per claim 13: Ritter teaches a method wherein at least one other pilot symbol from a different cell transmitted at the same time as the pilot symbols received from the base station collide each other (see page 6, lines 19-23). Collision is a function of inter-cell interference.

As per claim 14: Ritter teaches a method further comprising the base station selecting the sub-carriers from a set of candidate sub-carriers based on additional information available to the base station (see (see page 5, line 11-page 6, line 6; page 6, lines 19-23; page 14, line 9-page 13, line 3). For example, the inter-cell interference could be considered as additional information. Furthermore, examiner considers the claimed sub-carriers as being the subset of the prior art segment frequency spectrum.

As per claim 15: Ritter discloses a method, wherein the additional information comprises traffic load information (system capacity) on each cluster of sub-carriers (see page 14, line 9-page 15, line 3).

As per claim 16: Ritter discloses a method wherein, the traffic load information (system capacity information) is provided by a data buffer in the base station (see page 14, line 9-page 15, line 3). According to Ritter, the base station considers transmission condition and/or the capacity utilization of the radio cell overseen by the base station (see page 145, particularly lines 16-20), which indicates that the base station has knowledge of the cell's traffic load/capacity, which in turn indicates a storage of this information within the base station.

As per claim 17: Ritter teaches a method wherein the indication of sub-carriers is received via a downlink control channel (see page 5, line 5-page 6, line 6; page 23, lines 8-19).

As per claim 18: Ritter teaches a method wherein the plurality of sub-carriers comprises all sub-carriers allocable by a base station (see page 3, lines 9-19; page 5, line 11-page 6, line 23; claim 1).

As per claim 30: the features of claim 30 are similar to the features of claim 1, except claim 30 is directed to an apparatus intended to perform the steps of method claim 1. Hence, since the method steps of claim 1 are taught and the apparatus of claim 30 is required to perform the steps of claim 1, claim 30 has been rejected on the same ground and motivation as claim 1.

As per claim 31: Ritter discloses an apparatus, wherein each of the plurality of subscriber units continuously monitors reception of the pilot symbols known to the base station and the plurality of subscriber units (see page 20, lines 8-19; page 2, line 1-page 3, line 14) and measures signal-plus-noise (SINR) of each cluster of sub-carriers (see page 23, lines 8-19; page 5, line 16-21). A measure of signal quality includes a measure of SINR.

As per claim 37: the feature of claim 37 is similar to the feature of claim 8. Hence, claim 37 is rejected on the same ground as claim 8.

As per claim 43: the feature of claim 43 is similar to the feature of claim 14. Hence, claim 43 is rejected on the same ground and motivation as claim 14.

As per claim 44: the feature of claim 44 is similar to the feature of claim 15. Hence, claim 44 is rejected on the same ground as claim 15.

As per claim 45: the feature of claim 45 is similar to the feature of claim 16. Hence, claim 45 is rejected on the same ground as claim 16.

As per claim 46: Ritter teaches an apparatus wherein the indication of sub-carriers is received via a downlink control channel between the base station and the at least one subscriber (see page 27, line 23-page 28, line 6). It is known to transmit/receive control

information via a control channel and it is also know that a transmission from the base to the mobile unit is via a down link channel.

As per claim 47: Ritter teaches an apparatus wherein the plurality of sub-carriers comprises all sub-carriers allocable by a base station (see page 5, line 22-page 6, line 6; page 6, lines 7-18).

Claims 19, 20, 23, 48, 49 and 52 are rejected under 35 U.S.C. 103(a) as being unpatentable over Ritter as applied to claims 1 and 30 above, and further in view of Chuang et al. (Chuang) (US 6,052,594).

As per claim 19: Ritter does not explicitly teach about providing information comprising arbitrarily ordering the set of candidate of sub-carriers of sub-carriers. But, in the same field of endeavor, Chuang teaches about dynamically assigning channels wherein a wireless station selects the first L acceptable channels and sends a feedback message to the base station (see col. 8, lines 40-64; claim 1). Note: the wireless station arbitrarily orders the L acceptable channels into the list of L acceptable channels. Therefore, it would have been obvious for one of ordinary skill in the art at the time the invention was made to modify the teaching of Ritter with that of Chuang for the advantage of enabling a base station to deliver packet data to wireless stations using the channels that are listed as acceptable by the wireless stations.

As per claim 20: Chuang teaches a method wherein the arbitrary candidate clusters comprise clusters in an order with most desirable candidate cluster being listed first (see claim 1). Preferred traffic channel list according to priority order includes listing the most desirable channels listing first.

As per claim 23: the feature of claim 23 is similar to the feature of claim 20. Priority list includes or is a sequential order. Hence, claim 23 is rejected on the same ground and motivation as claim 20.

As per claim 48: the feature of claim 48 is similar to the feature of claim 19. Hence, claim 48 is rejected on the same ground and motivation as claim 19.

As per claim 49: the feature of claim 49 is similar to the feature of claim 20. Hence, claim 49 is rejected on the same ground and motivation as claim 20.

As per claim 52: the feature of claim 52 is similar to the feature of claim 23. Hence, claim 52 is rejected on the same ground and motivation as claim 23.

Claims 29 and 62 are rejected under 35 U.S.C. 103(a) as being unpatentable over Ritter and further in view of Feuerstein et al. (Feuerstein) (US 6,141,565).

As per claim 29: Ritter discloses an apparatus (see fig. 1; abstract), comprising:

a plurality of subscribers in a first cell (a cell) (see fig. 1) to generate feedback information indicating clusters of (group of sub-carriers) desired for use by the plurality of subscribers (see page 4, line 17-page 6, line 6). The base station and the mobile station of the prior art are in a cell.

a first base station (see fig. 1, element BS) in a first cell, the first base station performing sub-carrier allocation for OFDMA to allocate OFDMA sub-carriers in clusters (groups or numbers) to the plurality of subscriber units (see page 4, line 17-page 5, line 10) based on inter-cell interference avoidance (considered) in response to the feedback information (see page 6, line 19-page 7, line 9). Since there is no a second cell and a second base station mentioned, the prior art cell can be considered as a first cell and a

first base station. But Ritter does not explicitly teach about intra-cell traffic load balancing, as claimed by applicant. However, in a related field of endeavor, Feuerstein teaches about network optimization based on measured local interference and/or local traffic load conditions (see col. 2, lines 27-37). Therefore, it would have been obvious for one of ordinary skill in the art at the time the invention was made to modify Ritter with the teaching of Feuerstein for the advantage of optimizing network parameters based on dynamic communication and network conditions such as traffic load and balancing conditions and/or changing interference conditions (see col. 1, lines 20-26).

As per claim 62: the features of claim 62 are similar to the features of claim 29. Hence, claim 62 is rejected on the same ground and motivation as claim 29.

Claims 58 and 60 are rejected under 35 U.S.C. 103(a) as being unpatentable over Ritter In view of Hadad (US 6,985,432). For examination purpose, claim 58 is considered first.

As per claim 58: Ritter discloses a method comprising:

the base station allocating a plurality of sub-carriers (which could be labeled as a first portion) to establish a data link between the base station and the subscriber (see fig. 1; page 4, line 17-page 5, line 19); and . But, Ritter does not explicitly teach about a base station allocating a second portion of the sub-carriers to the subscriber to increase communication bandwidth, as claimed by applicant. However, in the same field of endeavor, Hadad teaches about OFDM communication channel wherein a group of sub-channels (sub-carriers) are allocated to different subscriber units by bandwidth On Demand (as needed), and can be managed using QoS and bandwidth requirements

(see col. 16, lines 45-59; col. 15, lines 30-42, lines 57-67). Therefore, it would have been obvious for one of ordinary skill in the art at the time the invention was made to modify the teaching of Ritter with that of Hadad for the advantage of allocating a set (group) of sub-channels (sub-carrier) to subscriber/s based on QoS and bandwidth considerations, as taught by Hadad.

.As per claim 60: the features of claim 60 are similar to the features of claim 58 except claim 60 is directed to a means which is required to perform the steps of method claim 58. Hence, since claim 58 is obviated, as discussed in the rejection of claim 58 above, claim 60 is rejected on the same ground and motivation as claim 58.

Allowable Subject Matter

Claims 7, 26, 27, 32, 33, 36, 55, 56, 59, 61 are objected to as being dependent upon a rejected base claim, but would be allowable if rewritten in independent form including all of the limitations of the base claim and any intervening claims. Claim 26 is objected in view of claim 1; claim 33 is objected because of its dependency on claim 32.

Response to Arguments

Applicant's arguments with respect to claims 1-4, 8, 12-20, 23, 29-31, 37, 43-49, 52 and 62 have been considered but are moot in view of the new ground(s) of rejection.

Conclusion

Any inquiry concerning this communication or earlier communications from the examiner should be directed to Meless N. Zewdu whose telephone number is (571) 272-7873. The examiner can normally be reached on 8:30 am to 5:00 pm..

If attempts to reach the examiner by telephone are unsuccessful, the examiner's supervisor, Appiah Charles can be reached on (571) 272-7904. The fax phone number for the organization where this application or proceeding is assigned is 571-273-8300.

Information regarding the status of an application may be obtained from the Patent Application Information Retrieval (PAIR) system. Status information for published applications may be obtained from either Private PAIR or Public PAIR. Status information for unpublished applications is available through Private PAIR only. For more information about the PAIR system, see <http://pair-direct.uspto.gov>. Should you have questions on access to the Private PAIR system, contact the Electronic Business Center (EBC) at 866-217-9197 (toll-free). If you would like assistance from a USPTO Customer Service Representative or access to the automated information system, call 800-786-9199 (IN USA OR CANADA) or 571-272-1000.

Application/Control Number:
11/199,586
Art Unit: 2617

Page 15

Any inquiry of a general nature relating to the status of this application or proceeding should be directed to the receptionist whose telephone number is (571) 272-2600.

Meless zewdu

Patent examiner

31 December 2007

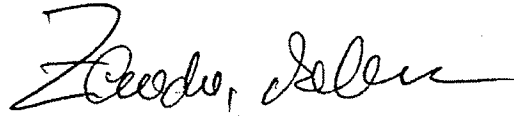
A handwritten signature in black ink, appearing to read "Zewdu, Meless". The signature is written in a cursive style with a large initial "Z".

REMARKS

Claims 1-4, 7-8, 12-20, 23, 26-27, 29-33, 36-37, 43-49, 52, 55-56, 58, 60, and 62 are pending. Claims 3, 7, 19, and 49 have been amended. Claims 59 and 61 has been cancelled. No new matter has been added. Applicant respectfully requests favorable reconsideration and allowance in light of the remarks contained herein.

Allowable Subject Matter

Claims 7, 26, 27, 32, 33, 36, 55, 56, 59, and 61 have been indicated as containing allowable subject matter. Applicant notes that claims 58 and 60 have been amended to contain the limitations of claims 59 and 61. Thus, independent claims 58 and 60 are in condition for allowance.

Claim Objections

Claims 7, 19, 49, and 59 have been objected to as containing informalities. Claims 7, 19, 49, and 59 have been amended to correct the informalities. As such, Applicant submits that the objections are overcome.

Claim Rejections 35 U.S.C. §112

Claim 3 is rejected under 35 U.S.C. §112 second paragraph, as being indefinite. More specifically, the Examiner takes issue with the term “the group of clusters” in line 2 as lacking antecedent basis. Claim 3 has been amended simply to provide antecedent basis for the limitation at issue. Therefore, Applicant submits that the rejection is overcome.

Double Patenting

Claims 1-4, 7, 8, 12-15, 17-20, 22, 26-27, 29-33, 36-37, 43-49, 52, 55, 56, and 58-62 are rejected on the ground of nonstatutory obviousness-type double patenting as being unpatentable

over claims 1-23 of U.S. Patent No. 6,947,748 B2.

The Examiner bases the non statutory double patenting rejection upon the notion that “the difference between the claims in the instant application and the claims in the [issued] patent is that the claims in the instant application are broader than the claims in the [issued] patent.” See Current Action, page 4. Applicant submits the idea that the pending claims may be broader than the issued claims (which form the basis of the rejection) is not, by itself, an appropriate rationale for a double patenting rejection. Non-statutory double patenting requires rejection of an application claim “when the claimed subject matter is not patentably distinct from the subject matter claim in the commonly owned patent.” See M.P.E.P. 804(II)(B)(1). In the case at hand, the Examiner’s assertion that the pending claims are broader than the issued claims is not determinative as to whether or not the pending claims are patentably distinct in view of the issued claims. Applicant respectfully notes that the Examiner’s statement is immaterial with respect to double patenting. As the Manual of Patent Examining Procedure correctly explains, “[d]omination and double patenting should not be confused Domination by itself, i.e., in the absence of statutory or nonstatutory double patenting grounds, cannot support a double patenting rejection.” *In re Kaplan*, 789 F.2d 1574, 1577-78 (Fed. Cir. 1986), cited in M.P.E.P. § 804(II). As such, there has not been provided a sufficient double patenting rejection. Therefore, Applicant requests reversal of the rejection of record.

Claim Rejections 35 U.S.C. §102

Claims 1-4, 8, 12-18, 30-31, 37, and 43-47 are rejected under 35 U.S.C. §102 as being anticipated by Ritter (DE 19800953, hereinafter “Ritter”). “A claim is anticipated only if each and every element as set forth in the claim is found, either expressly or inherently described, in a single prior art reference,” *Verdegaal Bros. v. Union Oil Co. of Cal.*, 814 F.2d 628, 631, 2 U.S.P.Q.2d 1051, 1053 (Fed. Cir. 1987). Because Ritter fails to teach each and every claim element in the present application, Applicant respectfully submits that the above rejections are improper.

Claim 1 recites “measuring channel and interference information for a plurality of subcarriers based on pilot symbols received from a base station.” Independent claim 30 recites a similar limitation. The Examiner cites to Ritter, at page 7, lines 1-9; page 12, lines 12-17, as satisfying measuring “based on pilot symbols received from a base station.” However, Applicant respectfully disagrees with the Examiner’s characterization of Ritter. Applicant points out there is no teaching in Ritter of a subscriber unit measuring channel and interference information *based on pilot symbols* received from a base station. Ritter generally describes OFDM communication between a base station and subscriber. The Examiner appears to equate to “data symbols” in OFDM communications to “pilot symbols.” However, these types of symbols are very different (*see, for example*, pending application at pg. 15 lns. 10-16). In any case, Applicant submits that there is no teaching in Ritter of a subscriber unit measuring channel and interference information based on pilot symbols received from a base station. The cited portions in Ritter merely discuss that the improved OFDMA multi-carrier procedure will transmit these “data symbols” more effectively. *See* Ritter, page 7, lines 1-9; page 12, lines 12-7. In any event, Applicant respectfully asserts that Ritter’s data symbols are not the same as pilot symbols received from a base station, as set forth in the claims.

Applicant’s argument is further supported by reference Ritter to at page 9 lines 8-14, which discusses measuring the quality of various segments of the frequency spectrum by determining the relative deviations of the amplitudes of the data symbols. However, Applicant reemphasizes that this description is different than what is required in claims 1 and 30, which is “measuring channel and interference information for a plurality of subcarriers based on pilot symbols.” Accordingly, Applicant requests reversal of the rejection of record.

Claims 2-4, 8, and 12-18 depend from claim 1 and claims 31, 37, and 43-47 depend from claim 30, respectively, and inherit every limitation of the claim from which they depend. As shown, the Examiner’s proposed combination fails to satisfy every limitation of claims 1 and 30. As such, claims 2-4, 8, 12-18, 31, 37, and 43-47 set forth limitations not taught or suggested by the Examiner’s proposed combination and are patentable at least by virtue of their dependency

on claims 1 and 30. In addition, these claims set forth limitations making them patentable in their own right.

For example, claim 13 recites “ wherein at least one other pilot symbol from a different cell transmitted at the same time as the pilot symbols received from the base station collide with each other.” The Examiner relies on Ritter, at page 6, lines 19-23, as satisfying this limitation. Current Action, page 7. Additionally, the Examiner states that collision is a function of inter-cell interference. *Id.* Applicant initially notes, however, that the Examiner fails to provide any support for his assertion. Most importantly, however, as discussed above, Ritter does not teach pilot symbols as set forth in the claims. It follows that Ritter also fails to satisfy “at least one other pilot symbol from a different cell transmitted at the same time as the pilot symbols received from the base station collide with each other,” as set forth in the claim. Hence, Applicant respectfully submits that the rejection of claim 13 is improper.

Claims 17 recites “wherein the indication of subcarriers is received via a downlink control channel.” Claim 46 recites a similar limitation. The Examiner points to Ritter, at page 5, line 5 -- page 6, line 6; page 23, lines 8-19, as satisfying this limitation. *See* Current Action, page 8. As discussed above, Ritter mentions only the base station evaluating the information received from the mobile stations and allocating a segment to each mobile station based on the evaluation, and a transmission means in the base station to transmit information across the assigned segment to each mobile station. Ritter, page 5, line 5 – page 6, line 6. There is no teaching in Ritter where the allocated segment information is received via a downlink control channel. Thus, Ritter does not satisfy this limitation of claim 17.

Claim Rejections 35 U.S.C. §103

Claims 19, 20, 23, 48, 49, and 52 are rejected under 35 U.S.C. § 103(a) as being unpatentable over the references applied to claim 1, and further in view Chuang et al. (U.S. Pat. No. 6,052,594, hereinafter Chuang). To establish prima facie obviousness of a claimed invention, all the claim limitations must be shown by the prior art. *In re Royka*, 490 F.2d 981,

180 U.S.P.Q. 580 (C.C.P.A. 1974). Because the proposed combination fails to teach multiple claim limitations as asserted by the Examiner, Applicant respectfully submits that the present rejections are improper.

Claims 19, 20, and 23 depend from claim 1 and claims 48, 49, and 52 depend from claim 30, respectively, and inherit every limitation of the claim from which they depend. As shown above, Ritter does not satisfy every limitation of claims 1 and 30. Moreover, Chuang is not relied upon to satisfy the missing limitations, nor does it do so. As such, claims 19, 20, 23, 48, 49, and 52 set forth limitations not satisfied by the proposed combination and are patentable at least by virtue of their dependency from claims 1 and 30.

Claims 29 and 62 are rejected under 35 U.S.C. § 103(a) as being unpatentable over Ritter in view of Feuerstein et al. (U.S. Patent No. 6,141,565, hereinafter Feuerstein).

In rejecting claims under 35 U.S.C. § 103, the Examiner bears the initial burden of establishing a *prima facie* case of obviousness. *In re Piasecki*, 745 F.2d 1468, 1472 (Fed. Cir. 1984). The Examiner can satisfy this burden by showing some articulated reasoning with some rational underpinning to support the legal conclusion of obviousness. *KSR Int'l. v. Teleflex Inc.*, 127 S. Ct 1727, 1741 (2007) (*citing In re Kahn*, 441 F.3d 977, 988 (Fed. Cir. 2006)). Only if this initial burden is met does the burden of coming forward with evidence or argument shift to the Applicant. *Piasecki*, 745 F.2d at 1472. Thus, the Examiner must not only assure that the requisite findings are made, based on evidence of record, but must also explain the reasoning by which the findings are deemed to support the Examiner's conclusion. Without conceding Examiner explained the reasoning by which the findings are deemed to support his conclusion, Applicant respectfully asserts that the present rejection fails to satisfy the requisite findings.

Independent claims 29 and 62 recite "base station performing subcarrier allocation...based on inter-cell interference avoidance and intra-cell traffic load balancing." The Examiner cites Ritter, at page 6, line 19 – page 7, line 9, as satisfying "based on inter-cell interference avoidance." *See Current Action*, page 11-12. However, the cited passages states

“by means of the invention, the interferences, especially...inter-cell interference... and inter-symbol interferences, are considered and compensated for.” Nothing in the cited portion suggests the base station utilizes the inter-cell interference avoidance in allocating radio resources to the mobile stations. Instead, the cited portion merely states that interferences are considered and compensated for without disclosing how interference is compensated for, much less that subcarrier allocation is based on interference avoidance, as set forth in the claim.

Furthermore, in the Current Action, at page 12, the Examiner acknowledges that Ritter does not satisfy subcarrier allocation based on intra-cell traffic load balancing. Instead, the Examiner points to Feuerstein, at col. 2, lines 27-37, as satisfying this limitation. *See* Current Action, pages 11-12. However, at the Examiner’s citation, Feuerstein describes changing network parameters according to “local interference and/or local traffic conditions” in order to optimize the network parameters. *See* Feuerstein at col. 2, lines 32-34. In discussing “local interference” Feuerstein contemplates traffic density distribution, etc. between cells. *Id.* at col. 2, lines 50-52. For example, according to Feuerstein, a mobile unit may request handoff based on the relative traffic loads between two cells. *Id.* at col. 6, lines 51-57. However, Applicant notes that merely evaluating relative traffic loads between two cells is not the same as allocating subcarriers based on traffic load balancing within a cell. Feuerstein does not contemplate evaluating load balancing within each cell. As such, Feuerstein does not satisfy performing subcarrier allocation based on intra-cell traffic load balancing, as set forth in the claim. As shown, the proposed combination fails to satisfy every claim limitation. Therefore, Applicant respectfully requests withdrawal of the rejection.

Claims 58 and 60 are rejected under 35 U.S.C. § 103(a) as being unpatentable over Ritter in view of Hadad (U.S. Pat. No. 6,985,432, hereinafter Hadad). Claims 58 and 60 have been amended to contain the limitations of claims 59 and 61 respectively. Hence, Applicant submits that this rejection is overcome.

Conclusion

In view of the above, Applicant believes the pending application is in condition for allowance. Applicant believes no fee is due with this response. However, if a fee is due, please charge Deposit Account No. 06-2380, under Order No. 68144/P014C1/10503148 from which the undersigned is authorized to draw.

Dated: April 10, 2008

Respectfully submitted,

By 

Robert L. Greeson

Registration No.: 52,966

FULBRIGHT & JAWORSKI L.L.P.

2200 Ross Avenue, Suite 2800

Dallas, Texas 75201-2784

(214) 855-7430

(214) 855-8200 (Fax)

Attorney for Applicant

I hereby certify that this paper (along with any paper referred to as being attached or enclosed) is being transmitted via the Office electronic filing system in accordance with § 1.6(a)(4).

Dated: April 10, 2008

Signature: 
Carol Martin

AMENDMENTS TO THE CLAIMS

1. (Previously Presented) A method for subcarrier selection for a system employing orthogonal frequency division multiple access (OFDMA) comprising:

a subscriber unit measuring channel and interference information for a plurality of subcarriers based on pilot symbols received from a base station;

the subscriber unit selecting a set of candidate subcarriers;

the subscriber unit providing feedback information on the set of candidate subcarriers to the base station; and

the subscriber unit receiving an indication of subcarriers of the set of subcarriers selected by the base station for use by the subscriber unit.

2. (Previously Presented) The method defined in Claim 1 further comprising the subscriber unit sending the indication to the base station.

3. (Currently Amended) The method defined in Claim 2 further comprising sending an indication of the set of subcarriers ~~group of clusters~~ selected by the base station for use by the subscriber unit.

4. (Previously Presented) The method defined in Claim 3 further comprising the base station selecting subcarriers for the subscriber unit based on inter-cell interference avoidance.

5. (Canceled)

6. (Canceled)

7. (Currently Amended) The method defined in Claim 1 further comprising the subscriber unit submitting new feedback information after being allocated the set of subcarriers ~~subscriber units~~ to be allocated a new set of subcarriers and thereafter the subscriber unit receiving another indication of the new set of subcarriers.

8. (Previously Presented) The method defined in Claim 1 further comprising the subscriber unit using information from pilot symbol periods and data periods to measure channel and interference information.

9. (Canceled)

10. (Canceled)

11. (Canceled)

12. (Original) The method defined in Claim 1 wherein the pilot symbols occupy an entire OFDM frequency bandwidth.

13. (Original) The method defined in Claim 12 wherein at least one other pilot symbol from a different cell transmitted at the same time as the pilot symbols received from the base station collide with each other.

14. (Original) The method defined in Claim 1 further comprising the base station selecting the subcarriers from the set of candidate subcarriers based on additional information available to the base station.

15. (Original) The method defined in Claim 14 wherein the additional information comprises traffic load information on each cluster of subcarriers.

16. (Original) The method defined in Claim 15 wherein the traffic load information is provided by a data buffer in the base station.

17. (Original) The method defined in Claim 1 wherein the indication of subcarriers is received via a downlink control channel.

18. (Original) The method defined in Claim 1 wherein the plurality of subcarriers comprises all subcarriers allocable by a base station.

19. (Currently Amended) The method defined in Claim 1 wherein providing feedback information comprises arbitrarily ordering the set of candidate [[of]] subcarriers as clusters of subcarriers.

20. (Original) The method defined in Claim 19 wherein arbitrarily order candidate clusters comprise clusters in an order with most desirable candidate clusters being listed first.

21. (Canceled)

22. (Canceled)

23. (Original) The method defined in Claim 1 wherein providing feedback information comprises sequentially ordering candidate clusters.

24. (Canceled)

25. (Canceled)

26. (Previously Presented) The method defined in Claim 1 further comprising:
the base station allocating a first portion of the subcarriers to establish a data link between the base station and the subscriber unit; and then
the base station allocating a second portion of the subcarriers to the subscriber unit to increase communication bandwidth.

27. (Previously Presented) The method defined in Claim 26 wherein the base station allocates the second portion after allocating each subscriber unit in the cell subcarriers to establish a data link between the base station and said each subscriber unit.

28. (Canceled)

29. (Presently Presented) An apparatus comprising:

a plurality of subscriber units in a first cell to generate feedback information indicating clusters of subcarriers desired for use by the plurality of subscriber units; and
a first base station in the first cell, the first base station performing subcarrier allocation for OFDMA to allocate OFDMA subcarriers in clusters to the plurality of subscriber units based on inter-cell interference avoidance and intra-cell traffic load balancing in response to the feedback information.

30. (Previously Presented) An apparatus comprising:

a plurality of subscriber units in a first cell operable to generate feedback information indicating clusters of subcarriers desired for use by the plurality of subscriber units; and
a first base station in the first cell, the first base station operable to allocate OFDMA subcarriers in clusters to the plurality of subscriber units;
each of said plurality of subscriber units to measure channel and interference information for the plurality of subcarriers based on pilot symbols received from the first base station and at least one of the plurality of subscriber units to select a set of candidate subcarriers from the plurality of subcarriers, and said at least one subscriber unit to provide feedback information on the set of candidate subcarriers to the base station and to receive an indication of subcarriers from the set of subcarriers selected by the first base station for use by the at least one subscriber unit.

31. (Previously Presented) The apparatus defined in Claim 30 wherein each of the plurality of subscriber units continuously monitors reception of the pilot symbols known to the base station and the plurality of subscriber units and measures signal-plus-interference-to-noise ratio (SINR) of each cluster of subcarriers.

32. (Previously Presented) The apparatus defined in Claim 31 wherein each of the plurality of subscriber units measures inter-cell interference, wherein the at least one subscriber unit selects candidate subcarriers based on the inter-cell interference.

33. (Previously Presented) The apparatus defined in Claim 32 wherein the base station selects subcarriers for the one subscriber unit based on inter-cell interference avoidance.

34. (Canceled)

35. (Canceled)

36. (Previously Presented) The apparatus defined in Claim 30 wherein the subscriber unit submits new feedback information after being allocated the set of subscriber units to receive a new set of subcarriers and thereafter receives another indication of the new set of subcarriers.

37. (Previously Presented) The apparatus defined in Claim 30 wherein the at least one subscriber unit uses information from pilot symbol periods and data periods to measure channel and interference information.

38-42. (Canceled)

43. (Original) The apparatus defined in Claim 30 wherein the base station selects the subcarriers from the set of candidate subcarriers based on additional information available to the base station.

44. (Original) The apparatus defined in Claim 43 wherein the additional information comprises traffic load information on each cluster of subcarriers.

45. (Original) The apparatus defined in Claim 44 wherein the traffic load information is provided by a data buffer in the base station.

46. (Previously Presented) The apparatus defined in Claim 30 wherein the indication of subcarriers is received via a downlink control channel between the base station and the at least one subscriber unit.

47. (Original) The apparatus defined in Claim 30 wherein the plurality of subcarriers comprises all subcarriers allocable by a base station.

48. (Previously Presented) The apparatus defined in Claim 30 wherein the plurality of subscriber units provide feedback information that comprises an arbitrarily ordered set of candidate subcarriers as clusters of subcarriers.

49. (Currently Amended) The apparatus defined in Claim 48 wherein arbitrarily ~~order~~ ordered candidate clusters comprise clusters in an order with most desirable candidate clusters being listed first.

50-51. (Canceled)

52. (Original) The apparatus defined in Claim 30 wherein providing feedback information comprises sequentially ordering candidate clusters.

53-54. (Canceled)

55. (Previously Presented) The apparatus defined in Claim 30 wherein the base station allocates a first portion of the subcarriers to establish a data link between the base station and the subscriber unit; and then allocates a second portion of the subcarriers to the subscriber unit to increase communication bandwidth.

56. (Previously Presented) The apparatus defined in Claim 55 wherein the base station allocates the second portion after allocating each subscriber unit in the cell subcarriers to establish a data link between the base station and said each subscriber unit.

57. (Canceled)

58. (Currently Amended) A method comprising:

a base station allocating a first portion of a plurality of subcarriers to establish a data link between the base station and a subscriber unit; and

the base station allocating a second portion of said plurality of subcarriers to the subscriber unit to increase communication bandwidth, wherein the base station allocates the second portion after allocating each subscriber unit in the cell subcarriers to establish a data link between the base station and said each subscriber unit.

59. (Canceled)

60. (Currently Amended) A base station comprising:

means for allocating a first portion of a plurality of subcarriers to establish a data link between the base station and a subscriber unit; and

means for allocating a second portion of said plurality of subcarriers to the subscriber unit to increase communication bandwidth, wherein the base station allocates the second portion after allocating each subscriber unit in the cell subcarriers to establish a data link between the base station and said each subscriber unit.

61. (Canceled)

62. (Previously Presented) An apparatus comprising:

a plurality of subscriber units in a cell; and

a base station in the cell, the base station to perform subcarrier allocation for OFDMA to allocate OFDMA subcarriers in clusters to the plurality of subscriber units based on inter-cell interference avoidance and intra-cell traffic load balancing.

IN THE UNITED STATES PATENT AND TRADEMARK OFFICE

In re Patent Application of:
Xiaodong Li et al.

Application No.: 11/199,586

Confirmation No.: 1128

Filed: August 8, 2005

Art Unit: 2617

For: OFDMA WITH ADAPTIVE SUBCARRIER-
CLUSTER CONFIGURATION AND
SELECTIVE LOADING

Examiner: M. N. Zewdu

RESPONSE TO NON-FINAL OFFICE ACTION

MS Amendment
Commissioner for Patents
P.O. Box 1450
Alexandria, VA 22313-1450

Dear Sir:

INTRODUCTORY COMMENTS

In response to the Office Action dated January 10, 2008 (hereinafter the "Current Action"), please consider the following:

Amendments to the Claims begin on page 2 of this paper.

Remarks/Arguments begin on page 9 of this paper.

Electronic Acknowledgement Receipt

EFS ID:	3136119
Application Number:	11199586
International Application Number:	
Confirmation Number:	1128
Title of Invention:	OFDMA with adaptive subcarrier-cluster configuration and selective loading
First Named Inventor/Applicant Name:	Xiaodong Li
Customer Number:	29053
Filer:	David H. Tannenbaum/Carol Martin
Filer Authorized By:	David H. Tannenbaum
Attorney Docket Number:	68144/P014C1/10503148
Receipt Date:	10-APR-2008
Filing Date:	08-AUG-2005
Time Stamp:	17:50:57
Application Type:	Utility under 35 USC 111(a)

Payment information:

Submitted with Payment	no
------------------------	----

File Listing:

Document Number	Document Description	File Name	File Size(Bytes) /Message Digest	Multi Part /.zip	Pages (if appl.)
1		AdaptixP014C110503148RN FOA.pdf	430245 <small>083bbcc318e7b711082d32d606bd3d5 4f1d70e9b</small>	yes	15

Multipart Description/PDF files in .zip description

Document Description	Start	End
Amendment - After Non-Final Rejection	1	1
Claims	2	8
Applicant Arguments/Remarks Made in an Amendment	9	15

Warnings:

Information:

Total Files Size (in bytes):	430245
-------------------------------------	--------

This Acknowledgement Receipt evidences receipt on the noted date by the USPTO of the indicated documents, characterized by the applicant, and including page counts, where applicable. It serves as evidence of receipt similar to a Post Card, as described in MPEP 503.

New Applications Under 35 U.S.C. 111

If a new application is being filed and the application includes the necessary components for a filing date (see 37 CFR 1.53(b)-(d) and MPEP 506), a Filing Receipt (37 CFR 1.54) will be issued in due course and the date shown on this Acknowledgement Receipt will establish the filing date of the application.

National Stage of an International Application under 35 U.S.C. 371

If a timely submission to enter the national stage of an international application is compliant with the conditions of 35 U.S.C. 371 and other applicable requirements a Form PCT/DO/EO/903 indicating acceptance of the application as a national stage submission under 35 U.S.C. 371 will be issued in addition to the Filing Receipt, in due course.

New International Application Filed with the USPTO as a Receiving Office

If a new international application is being filed and the international application includes the necessary components for an international filing date (see PCT Article 11 and MPEP 1810), a Notification of the International Application Number and of the international Filing Date (Form PCT/RO/105) will be issued in due course, subject to prescriptions concerning national security, and the date shown on this Acknowledgement Receipt will establish the international filing date of the application.

Under the Paperwork Reduction Act of 1995, no persons are required to respond to a collection of information unless it displays a valid OMB control number.

PATENT APPLICATION FEE DETERMINATION RECORD Substitute for Form PTO-875	Application or Docket Number 11/199,586	Filing Date 08/08/2005	<input type="checkbox"/> To be Mailed
---	---	----------------------------------	---------------------------------------

APPLICATION AS FILED – PART I			OTHER THAN SMALL ENTITY				
FOR	NUMBER FILED (Column 1)	NUMBER EXTRA (Column 2)	SMALL ENTITY <input checked="" type="checkbox"/>	OR	OTHER THAN SMALL ENTITY		
			RATE (\$)	FEE (\$)		RATE (\$)	FEE (\$)
<input type="checkbox"/> BASIC FEE <small>(37 CFR 1.16(a), (b), or (c))</small>	N/A	N/A	N/A			N/A	
<input type="checkbox"/> SEARCH FEE <small>(37 CFR 1.16(k), (j), or (m))</small>	N/A	N/A	N/A			N/A	
<input type="checkbox"/> EXAMINATION FEE <small>(37 CFR 1.16(o), (p), or (q))</small>	N/A	N/A	N/A			N/A	
TOTAL CLAIMS <small>(37 CFR 1.16(j))</small>	minus 20 =	*	X \$ =		OR	X \$ =	
INDEPENDENT CLAIMS <small>(37 CFR 1.16(h))</small>	minus 3 =	*	X \$ =			X \$ =	
<input type="checkbox"/> APPLICATION SIZE FEE <small>(37 CFR 1.16(s))</small>	If the specification and drawings exceed 100 sheets of paper, the application size fee due is \$250 (\$125 for small entity) for each additional 50 sheets or fraction thereof. See 35 U.S.C. 41(a)(1)(G) and 37 CFR 1.16(s).						
<input type="checkbox"/> MULTIPLE DEPENDENT CLAIM PRESENT <small>(37 CFR 1.16(j))</small>							
* If the difference in column 1 is less than zero, enter "0" in column 2.			TOTAL			TOTAL	

APPLICATION AS AMENDED – PART II					OTHER THAN SMALL ENTITY					
	(Column 1)	(Column 2)	(Column 3)	(Column 3)	SMALL ENTITY	OR	OTHER THAN SMALL ENTITY			
AMENDMENT	04/10/2008	CLAIMS REMAINING AFTER AMENDMENT	HIGHEST NUMBER PREVIOUSLY PAID FOR	PRESENT EXTRA	RATE (\$)	ADDITIONAL FEE (\$)		RATE (\$)	ADDITIONAL FEE (\$)	
	Total <small>(37 CFR 1.16(i))</small>	* 38	Minus	** 40	= 0	X \$25 =	0	OR	X \$ =	
	Independent <small>(37 CFR 1.16(h))</small>	* 6	Minus	*** 6	= 0	X \$105 =	0	OR	X \$ =	
	<input type="checkbox"/> Application Size Fee <small>(37 CFR 1.16(s))</small>									
	<input type="checkbox"/> FIRST PRESENTATION OF MULTIPLE DEPENDENT CLAIM <small>(37 CFR 1.16(j))</small>									
					TOTAL ADD'L FEE	0		TOTAL ADD'L FEE		

	(Column 1)	(Column 2)	(Column 3)	(Column 3)	SMALL ENTITY	OR	OTHER THAN SMALL ENTITY		
AMENDMENT		CLAIMS REMAINING AFTER AMENDMENT	HIGHEST NUMBER PREVIOUSLY PAID FOR	PRESENT EXTRA	RATE (\$)	ADDITIONAL FEE (\$)		RATE (\$)	ADDITIONAL FEE (\$)
	Total <small>(37 CFR 1.16(i))</small>	*	Minus	**	=	X \$ =		X \$ =	
	Independent <small>(37 CFR 1.16(h))</small>	*	Minus	***	=	X \$ =		X \$ =	
	<input type="checkbox"/> Application Size Fee <small>(37 CFR 1.16(s))</small>								
	<input type="checkbox"/> FIRST PRESENTATION OF MULTIPLE DEPENDENT CLAIM <small>(37 CFR 1.16(j))</small>								
					TOTAL ADD'L FEE		TOTAL ADD'L FEE		

* If the entry in column 1 is less than the entry in column 2, write "0" in column 3.
 ** If the "Highest Number Previously Paid For" IN THIS SPACE is less than 20, enter "20".
 *** If the "Highest Number Previously Paid For" IN THIS SPACE is less than 3, enter "3".
 The "Highest Number Previously Paid For" (Total or Independent) is the highest number found in the appropriate box in column 1.

Legal Instrument Examiner:
/BRENDA HINES/

This collection of information is required by 37 CFR 1.16. The information is required to obtain or retain a benefit by the public which is to file (and by the USPTO to process) an application. Confidentiality is governed by 35 U.S.C. 122 and 37 CFR 1.14. This collection is estimated to take 12 minutes to complete, including gathering, preparing, and submitting the completed application form to the USPTO. Time will vary depending upon the individual case. Any comments on the amount of time you require to complete this form and/or suggestions for reducing this burden, should be sent to the Chief Information Officer, U.S. Patent and Trademark Office, U.S. Department of Commerce, P.O. Box 1450, Alexandria, VA 22313-1450. DO NOT SEND FEES OR COMPLETED FORMS TO THIS ADDRESS. **SEND TO: Commissioner for Patents, P.O. Box 1450, Alexandria, VA 22313-1450.**

If you need assistance in completing the form, call 1-800-PTO-9199 and select option 2.



UNITED STATES PATENT AND TRADEMARK OFFICE

UNITED STATES DEPARTMENT OF COMMERCE
United States Patent and Trademark Office
Address: COMMISSIONER FOR PATENTS
P.O. Box 1450
Alexandria, Virginia 22313-1450
www.uspto.gov

APPLICATION NO.	FILING DATE	FIRST NAMED INVENTOR	ATTORNEY DOCKET NO.	CONFIRMATION NO.
11/199,586	08/08/2005	Xiaodong Li	68144/P014C1/10503148	1128

29053 7590 06/03/2008
FULBRIGHT & JAWORSKI L.L.P
2200 ROSS AVENUE
SUITE 2800
DALLAS, TX 75201-2784

EXAMINER
ZEWDU, MELESS NMN

ART UNIT 2617
PAPER NUMBER

MAIL DATE 06/03/2008
DELIVERY MODE PAPER

Please find below and/or attached an Office communication concerning this application or proceeding.

The time period for reply, if any, is set in the attached communication.

Office Action Summary

Application No.

11/199,586

Applicant(s)

LI ET AL.

Examiner

Meless N. Zewdu

Art Unit

2617

-- The MAILING DATE of this communication appears on the cover sheet with the correspondence address --

Period for Reply

A SHORTENED STATUTORY PERIOD FOR REPLY IS SET TO EXPIRE 3 MONTH(S) OR THIRTY (30) DAYS, WHICHEVER IS LONGER, FROM THE MAILING DATE OF THIS COMMUNICATION.

- Extensions of time may be available under the provisions of 37 CFR 1.136(a). In no event, however, may a reply be timely filed after SIX (6) MONTHS from the mailing date of this communication.
- If NO period for reply is specified above, the maximum statutory period will apply and will expire SIX (6) MONTHS from the mailing date of this communication.
- Failure to reply within the set or extended period for reply will, by statute, cause the application to become ABANDONED (35 U.S.C. § 133). Any reply received by the Office later than three months after the mailing date of this communication, even if timely filed, may reduce any earned patent term adjustment. See 37 CFR 1.704(b).

Status

- 1) Responsive to communication(s) filed on 10 April 2008.
- 2a) This action is **FINAL**. 2b) This action is non-final.
- 3) Since this application is in condition for allowance except for formal matters, prosecution as to the merits is closed in accordance with the practice under *Ex parte Quayle*, 1935 C.D. 11, 453 O.G. 213.

Disposition of Claims

- 4) Claim(s) See Continuation Sheet is/are pending in the application.
- 4a) Of the above claim(s) _____ is/are withdrawn from consideration.
- 5) Claim(s) 58 and 60 is/are allowed.
- 6) Claim(s) 1-4, 7-8, 12-20, 23, 29-31, 36-37, 43-49, 52 and 62 is/are rejected.
- 7) Claim(s) 26,27,32,33,55 and 56 is/are objected to.
- 8) Claim(s) _____ are subject to restriction and/or election requirement.

Application Papers

- 9) The specification is objected to by the Examiner.
- 10) The drawing(s) filed on _____ is/are: a) accepted or b) objected to by the Examiner.
Applicant may not request that any objection to the drawing(s) be held in abeyance. See 37 CFR 1.85(a).
Replacement drawing sheet(s) including the correction is required if the drawing(s) is objected to. See 37 CFR 1.121(d).
- 11) The oath or declaration is objected to by the Examiner. Note the attached Office Action or form PTO-152.

Priority under 35 U.S.C. § 119

- 12) Acknowledgment is made of a claim for foreign priority under 35 U.S.C. § 119(a)-(d) or (f).
- a) All b) Some * c) None of:
1. Certified copies of the priority documents have been received.
 2. Certified copies of the priority documents have been received in Application No. _____.
 3. Copies of the certified copies of the priority documents have been received in this National Stage application from the International Bureau (PCT Rule 17.2(a)).

* See the attached detailed Office action for a list of the certified copies not received.

Attachment(s)

- 1) Notice of References Cited (PTO-892)
- 2) Notice of Draftsperson's Patent Drawing Review (PTO-948)
- 3) Information Disclosure Statement(s) (PTO/SB/08)
Paper No(s)/Mail Date _____
- 4) Interview Summary (PTO-413)
Paper No(s)/Mail Date. _____
- 5) Notice of Informal Patent Application
- 6) Other: _____

Continuation of Disposition of Claims: Claims pending in the application are 1-4, 7-8, 12-20, 23, 26-27, 29-33, 36-37, 43-49, 52, 55-56, 58, 60 and 62.

DETAILED ACTION

Response to Amendment

1. This action is in response to the communication filed on 4/10/08.
2. Claims 5-6, 9-11, 21-22, 24-25, 28, 34-35, 38-42, 50-51, 53-54, 57, 59 and 61 have been cancelled.
3. Claims 1-4, 7-8, 12-20, 23, 26-27, 29-33, 36-37, 43-49, 52, 55-56, 58, 60 and 62 are pending in this action.
4. This action is final.

Claim Objections

Claim 49 is objected to because of the following informalities: the claim recites “**wherein arbitrarily ordered candidate clusters comprise clusters in an order with most desirable candidate cluster being listed first” (emphasis added). An arbitrarily ordered cluster may by chance include or exclude an ordered cluster. Appropriate correction is required.**

Claim 29 objected to because of the following informalities: the status indicator “**presently presented**” should be --- previously presented. Appropriate correction is required.

Claim Rejections - 35 USC § 112

The following is a quotation of the first paragraph of 35 U.S.C. 112:

The specification shall contain a written description of the invention, and of the manner and process of making and using it, in such full, clear, concise, and exact terms as to enable any person skilled in the art to which it pertains, or with which it is most nearly connected, to make and use the same and shall set forth the best mode contemplated by the inventor of carrying out his invention.

Claims 7 and 36 are rejected under 35 U.S.C. 112, first paragraph, as failing to comply with the written description requirement. The claim(s) contains subject matter which was not described in the specification in such a way as to reasonably convey to one skilled in the relevant art that the inventor(s), at the time the application was filed, had possession of the claimed invention. "New feedback information" is not disclosed in the specification in a manner as claimed in the claims in question.

Double Patenting

The nonstatutory double patenting rejection is based on a judicially created doctrine grounded in public policy (a policy reflected in the statute) so as to prevent the unjustified or improper timewise extension of the "right to exclude" granted by a patent and to prevent possible harassment by multiple assignees. A nonstatutory obviousness-type double patenting rejection is appropriate where the conflicting claims are not identical, but at least one examined application claim is not patentably distinct from the reference claim(s) because the examined application claim is either anticipated by, or would have been obvious over, the reference claim(s). See, e.g., *In re Berg*, 140 F.3d 1428, 46 USPQ2d 1226 (Fed. Cir. 1998); *In re Goodman*, 11 F.3d 1046, 29 USPQ2d 2010 (Fed. Cir. 1993); *In re Longi*, 759 F.2d 887, 225 USPQ 645 (Fed. Cir. 1985); *In re Van Ornum*, 686 F.2d 937, 214 USPQ 761 (CCPA 1982); *In re Vogel*, 422 F.2d 438, 164 USPQ 619 (CCPA 1970); and *In re Thorington*, 418 F.2d 528, 163 USPQ 644 (CCPA 1969).

A timely filed terminal disclaimer in compliance with 37 CFR 1.321(c) or 1.321(d) may be used to overcome an actual or provisional rejection based on a

Art Unit: 2617

nonstatutory double patenting ground provided the conflicting application or patent either is shown to be commonly owned with this application, or claims an invention made as a result of activities undertaken within the scope of a joint research agreement.

Effective January 1, 1994, a registered attorney or agent of record may sign a terminal disclaimer. A terminal disclaimer signed by the assignee must fully comply with 37 CFR 3.73(b).

Claims 1-4, 7-8, 12-15, 17-20, 22, 26-27, 29-33, 36-37, 43-49, 52, 55-56 and 58-62 are rejected on the ground of nonstatutory obviousness-type double patenting as being unpatentable over claims 1-23 of U.S. Patent No. 6,947,748 B2. Although the conflicting claims are not identical, they are not patentably distinct from each other because the difference between the claims in the instant application and claims in the patent is that the claims in the instant claims are broader than the claims in the patent. In other words, the features omitted in the instant claims are inherent. For example, consider the following.

Claims 1-3 in the application read on at least claim 1 in the patent.

Claim 29 in the application reads on claim 11 in the patent.

Claims 7, 30, 36, 31 and 61 in the application read on claim 23 in the patent. In the case of claims 7 and 36, the new feedback information could be associated with a new request, i.e., when the subscriber access the base station a second time.

Claims 4, 32 and 33 in the application read on claims 2 and 16 in the patent.

Claims 8 and 37 in the application read on claims 5 and 16 in the patent.

Claim 12 in the application reads on claim 17 in the patent.

Claim 13 in the application reads on claim 18 in the patent.

Art Unit: 2617

Claims 14-15 and 43 -44 in the application read on claims 12-13, 16 and or 23, wherein the traffic-load information could be interpreted as an additional information to the channel and interference information recited in claim 1 (in the application).

Claims 16 and 45 in the application read on claims 11-13 in the patent. In claims 12-13, particularly in claim 13, it is described that base station balances intra-cell traffic load. Hence, the base station must inherently have a buffer or an equivalent memory to store the traffic-load data.

Claim 17 in the application reads on claims 5 and/or 6 of the patent. An 'indication' is a control signal that must be transmitted via a control channel and a 'downlink' is a transmitting direction from a base station to a mobile station, all of which are discernable from claim 5 of the patent.

Claims 18 and 47 in the application read on claim 17 in the patent.

Claims 19, 20, 23, 46, 48, 49 and 52 in the application read on claims 6 and 19 in the patent. Orderly list in claim 20 and sequential order in claims 23 and 52 (in the application) reads on indexing in claims 6 and 19 in the patent.

Claims 26, 58 and 60 in the patent read on claim 10 and/or 23 of the patent.

Claims 27 and 56 in the application read on claim 10 of the patent.

Claims 29 and 62 in the application read on claim 11 of the patent.

Claim 55 in the application read on claims 10-12, 14, 19, 21 and 23 of the patent. In the indicated claims of the patent, it is shown that the base station allocates sub-carriers to a plurality of subscribers in a cell. In claims 10 and 23, it

is indicated that a particular subscriber is allocated with a first and second portions of sub-carriers due to a priority. In the final analysis, the scope of the claims in the issued patent covers the entire scope of the claims in the instant application. The difference between the claims in the instant application and the claims in the patent is that the claims in the instant application are broader than the claims in the patent.

Claim Rejections - 35 USC § 102

The following is a quotation of the appropriate paragraphs of 35 U.S.C. 102 that form the basis for the rejections under this section made in this Office action:

A person shall be entitled to a patent unless –

(b) the invention was patented or described in a printed publication in this or a foreign country or in public use or on sale in this country, more than one year prior to the date of application for patent in the United States.

Claims 1-4, 8, 12-18, 30-31, 37 and 43-47 are rejected under 35

U.S.C. 102(b) as being anticipated by Ritter (DE 19800953).

As per claim 1: while **OFDMA** in claim 1 is considered as an intended use (for lacking to enhance the body of the claims), Ritter discloses a method for sub-carrier selection for a system employing orthogonal frequency division multiple access (OFDMA) (see fig. in page 2), comprising:

a subscriber unit measuring channel and interference information (see page 6, lines 19-23) for a plurality of sub-carriers (page 5, lines 11-19) based on

Art Unit: 2617

pilot symbols received from a base station (see page 7, lines 1-9; page 12, lines 12-17);

the subscriber unit selecting a set of candidate sub-carriers (see page 5, line 11-page 6, line 6). The prior art shows a subscriber selecting a suitable segment (sub-carriers). It is to be noted, that selection requires candidacy (in this case candidate sub-carrier selection).

the subscriber unit providing feedback information on the set of candidate sub-carriers to the base station (see page 5, lines 16-21);

the subscriber unit receiving an indication of sub-carriers of the set of sub-carriers selected by the base station for use by the subscriber (see page 5, line 22-page 6, line 6).

As per claim 2: Ritter teaches a method further comprising the subscriber unit sending the indication to the base station (see page 5, lines 16-21).

As per claim 3: Ritter discloses a method, further comprising sending an indication of the group cluster (sub-carriers) unit (see page 5, line 11-page 6, line 23).

As per claim 4: Ritter discloses a method, further comprising the base station selecting sub-carriers for the subscriber unit based on inter-cell interference avoidance (inter-cell consideration) (see page 6, lines 7-23).

As per claim 8: Ritter teaches a method, further comprising the subscriber unit using information from pilot periods and data to measure channel and interference information (see page 2, line 9-page 4, line 2; claim 11).

Art Unit: 2617

As per claim 12: Ritter teaches a method wherein the pilot symbols occupy an entire OFDM frequency bandwidth (see page 3, lines 9-19; page 6, lines 7-23; claim 1).

As per claim 13: Ritter teaches a method wherein at least one other pilot symbol from a different cell transmitted at the same time as the pilot symbols received from the base station collide each other (see page 6, lines 19-23). Collision is a function of inter-cell interference.

As per claim 14: Ritter teaches a method further comprising the base station selecting the sub-carriers from a set of candidate sub-carriers based on additional information available to the base station (see (see page 5, line 11- page 6, line 6; page 6, lines 19-23; page 14, line 9-page 13, line 3). For example, the inter-cell interference could be considered as additional information. Furthermore, examiner considers the claimed sub-carriers as being the subset of the prior art segment frequency spectrum.

As per claim 15: Ritter discloses a method, wherein the additional information comprises traffic load information (system capacity) on each cluster of sub-carriers (see page 14, line 9-page 15, line 3).

As per claim 16: Ritter discloses a method wherein, the traffic load information (system capacity information) is provided by a data buffer in the base station (see page 14, line 9-page 15, line 3). According to Ritter, the base station considers transmission condition and/or the capacity utilization of the radio cell overseen by the base station (see page 145, particularly lines 16-20), which indicates that the

Art Unit: 2617

base station has knowledge of the cell's traffic load/capacity, which in turn indicates a storage of this information within the base station.

As per claim 17: Ritter teaches a method wherein the indication of sub-carriers is received via a downlink control channel (see page 5, line 5-page 6, line 6; page 23, lines 8-19).

As per claim 18: Ritter teaches a method wherein the plurality of sub-carriers comprises all sub-carriers allocable by a base station (see page 3, lines 9-19; page 5, line 11-page 6, line 23; claim 1).

As per claim 30: the features of claim 30 are similar to the features of claim 1, except claim 30 is directed to an apparatus intended to perform the steps of method claim 1. Hence, since the method steps of claim 1 are taught and the apparatus of claim 30 is required to perform the steps of claim 1, claim 30 has been rejected on the same ground and motivation as claim 1.

As per claim 31: Ritter discloses an apparatus, wherein each of the plurality of subscriber units continuously monitors reception of the pilot symbols known to the base station and the plurality of subscriber units (see page 20, lines 8-19; page 2, line 1-page 3, line 14) and measures signal-plus-noise (SINR) of each cluster of sub-carriers (see page 23, lines 8-19; page 5, line 16-21). A measure of signal quality includes a measure of SINR.

As per claim 37: the feature of claim 37 is similar to the feature of claim 8. Hence, claim 37 is rejected on the same ground as claim 8.

As per claim 43: the feature of claim 43 is similar to the feature of claim 14. Hence, claim 43 is rejected on the same ground and motivation as claim 14.

Art Unit: 2617

As per claim 44: the feature of claim 44 is similar to the feature of claim 15.

Hence, claim 44 is rejected on the same ground as claim 15.

As per claim 45: the feature of claim 45 is similar to the feature of claim 16.

Hence, claim 45 is rejected on the same ground as claim 16.

As per claim 46: Ritter teaches an apparatus wherein the indication of sub-carriers is received via a downlink control channel between the base station and the at least one subscriber (see page 27, line 23-page 28, line 6). It is known to transmit/receive control information via a control channel and it is also known that a transmission from the base to the mobile unit is via a down link channel.

As per claim 47: Ritter teaches an apparatus wherein the plurality of sub-carriers comprises all sub-carriers allocable by a base station (see page 5, line 22-page 6, line 6; page 6, lines 7-18).

Claims 19, 20, 23, 48, 49 and 52 are rejected under 35 U.S.C. 103(a) as being unpatentable over Ritter as applied to claims 1 and 30 above, and further in view of Chuang et al. (Chuang) (US 6,052,594).

As per claim 19: Ritter does not explicitly teach about providing information comprising arbitrarily ordering the set of candidate of sub-carriers of sub-carriers. But, in the same field of endeavor, Chuang teaches about dynamically assigning channels wherein a wireless station selects the first L acceptable channels and sends a feedback message to the base station (see col. 8, lines 40-64; claim 1). Note: the wireless station arbitrarily orders the L acceptable channels into the list of L acceptable channels. Therefore, it would have been obvious for one of ordinary skill in the art at the time the invention was made to modify the teaching

Art Unit: 2617

of Ritter with that of Chuang for the advantage of enabling a base station to deliver packet data to wireless stations using the channels that are listed as acceptable by the wireless stations.

As per claim 20: Chuang teaches a method wherein the arbitrary candidate clusters comprise clusters in an order with most desirable candidate cluster being listed first (see claim 1). Preferred traffic channel list according to priority order includes listing the most desirable channels listing first.

As per claim 23: the feature of claim 23 is similar to the feature of claim 20. Priority list includes or is a sequential order. Hence, claim 23 is rejected on the same ground and motivation as claim 20.

As per claim 48: the feature of claim 48 is similar to the feature of claim 19. Hence, claim 48 is rejected on the same ground and motivation as claim 19.

As per claim 49: the feature of claim 49 is similar to the feature of claim 20. Hence, claim 49 is rejected on the same ground and motivation as claim 20.

As per claim 52: the feature of claim 52 is similar to the feature of claim 23. Hence, claim 52 is rejected on the same ground and motivation as claim 23.

Claims 29 and 62 are rejected under 35 U.S.C. 103(a) as being unpatentable over Ritter and further in view of Feuerstein et al. (Feuerstein) (US 6,141,565).

As per claim 29: Ritter discloses an apparatus (see fig. 1; abstract), comprising:
a plurality of subscribers in a first cell (a cell) (see fig. 1) to generate feedback information indicating clusters of (group of sub-carriers) desired for use

Art Unit: 2617

by the plurality of subscribers (see page 4, line 17-page 6, line 6). The base station and the mobile station of the prior art are in a cell.

a first base station (see fig. 1, element BS) in a first cell, the first base station performing sub-carrier allocation for OFDMA to allocate OFDMA sub-carriers in clusters (groups or numbers) to the plurality of subscriber units (see page 4, line 17-page 5, line 10) based on inter-cell interference avoidance (considered) in response to the feedback information (see page 6, line 19-page 7, line 9). Since there is no a second cell and a second base station mentioned, the prior art cell can be considered as a first cell and a first base station. But, within the contest of claim 29, Ritter does not explicitly teach about intra-cell traffic load balancing, as claimed by applicant. However, in a related field of endeavor, Feuerstein teaches about network optimization based on measured local interference and/or local traffic load conditions (see col. 2, lines 27-37). Therefore, it would have been obvious for one of ordinary skill in the art at the time the invention was made to modify Ritter with the teaching of Feuerstein for the advantage of optimizing network parameters based on dynamic communication and network conditions such as traffic load and balancing conditions and/or changing interference conditions (see col. 1, lines 20-26).

As per claim 62: the features of claim 62 are similar to the features of claim 29. Hence, claim 62 is rejected on the same ground and motivation as claim 29.

Claims 58 and 60 are rejected under 35 U.S.C. 103(a) as being unpatentable over Ritter In view of Hadad (US 6,985,432). For examination purpose, claim 58 is considered first.

As per claim 58: Ritter discloses a method comprising:

the base station allocating a plurality of sub-carriers (which could be labeled as a first portion) to establish a data link between the base station and the subscriber (see fig. 1; page 4, line 17-page 5, line 19); and . But, Ritter does not explicitly teach about a base station allocating a second portion of the sub-carriers to the subscriber to increase communication bandwidth, as claimed by applicant. However, in the same field of endeavor, Hadad teaches about OFDM communication channel wherein a group of sub-channels (sub-carriers) are allocated to different subscriber units by bandwidth On Demand (as needed), and can be managed using QoS and bandwidth requirements (see col. 16, lines 45-59; col. 15, lines 30-42, lines 57-67). Therefore, it would have been obvious for one of ordinary skill in the art at the time the invention was made to modify the teaching of Ritter with that of Hadad for the advantage of allocating a set (group) of sub-channels (sub-carrier) to subscriber/s based on QoS and bandwidth considerations, as taught by Hadad.

.As per claim 60: the features of claim 60 are similar to the features of claim 58 except claim 60 is directed to a means which is required to perform the steps of method claim 58. Hence, since claim 58 is obviated, as discussed in the rejection of claim 58 above, claim 60 is rejected on the same ground and motivation as claim 58.

Allowable Subject Matter

Claims 58 and 60 are allowed.

The following is an examiner's statement of reasons for allowance: the prior art of record does not teach or fairly suggest --- a base station allocating a second portion of sub-carriers to a subscriber, in addition to a first portion allocated before, after allocating each subscriber unit in a cell sub-carriers to establish a data link between the base station and each subscriber unit, as recited to the claims mentioned.

Claims 7 and 36 would be allowable if rewritten to overcome the rejection(s) under 35 U.S.C. 112, 2nd paragraph, set forth in this Office action and to include all of the limitations of the base claim and any intervening claims.

Claims 26, 27, 32, 33, 55 and 56 are objected to as being dependent upon a rejected base claim, but would be allowable if rewritten in independent form including all of the limitations of the base claim and any intervening claims. Claim 26 is objected in view of claim 1; claim 33 is objected because of its dependency on claim 32.

Any comments considered necessary by applicant must be submitted no later than the payment of the issue fee and, to avoid processing delays, should preferably accompany the issue fee. Such submissions should be clearly labeled "Comments on Statement of Reasons for Allowance."

Response to Arguments

Applicant's arguments filed 4/10/08 have been fully considered but they are not persuasive. Applicant's arguments and corresponding examiner's response follow.

Argument I: with regard to all live/pending claims as they relate to the non statutory double patenting rejection, applicant argues by saying “**applicant submits the idea that the pending claims may be broader than the issued claims (which form the basis of the rejection) is not, by itself, an appropriate rationale for double patenting rejection**”, (emphasis added).

Response I: examiner respectfully disagrees with the argument. As applicant correctly pointed out though, examiner agrees that a non statutory double patenting requires rejection of an application claim “when the claimed subject matter is not patentably distinct from the subject matter claimed in the commonly owned patent.” That is what, in essence, the examiner is maintaining. In words, the pending claims, except being broader than the claims in the commonly owned issued patent, are not patentably distinct from the claims of the patent in question. Or differently stated, the features of the narrow claims are inherent within the scope of the broader claims. Further yet, examiner does not begin and end with the statement mentioned above. Which pending claim corresponds/reads on/ to which claim in the issued patent is clearly shown laid out. Thus, the argument regarding the non statutory double patenting rejection is found to be unconvincing.

Argument II: with regard to claims 1 and 30, applicant asserts, there is not teaching in Ritter of a subscriber unit, "measuring channel and interference information based on pilot symbols received from a base station."

Response II: examiner respectfully disagrees with the argument. In that, while noting that a reference must be considered as a whole, Ritter's reference teaches about OFDMA sub-carrier allocation (page 6) wherein a mobile station receives data symbols from its base station and measures quality of various segments (group of channels) (see pages 6, 9, 18; claim 1) . As can be seen, the mobile /measures inter-cell interferences and inter-symbol interferences (see pages 5-6). Furthermore, applicant alleges that the claimed "pilot symbol" is different from Ritter's "data symbol" without pointing out the difference. Even one agrees with the argument, the pilot symbol must be an inherent feature or there exists an equivalent mechanism in Ritter, since Ritter's mobile station measures a suitable quality segment of a frequency spectrum. It is to be noted quality measurement can include measuring channel interference. Thus, the argument is not found to be convincing.

Argument III: with regard to claim 13, applicant argues Ritter does not teach " wherein at least one other pilot from a different cell transmitted at the same time as the pilot symbols received from the base station collides with each other."

Response III: examiner disagrees with the argument. First, the collision of two pilot symbols does not produce or provide an inventive feature; or applicant does not provide or say what the resulting inventive feature of the

collision. Differently stated, the collision of signals does not provide a positive result. Second, it is apparent in Ritter that if inter-cell signals are allowed to collide, they will. In other words, interference is or at least includes signals' collision. The argument is not convincing.

Argument IV: regarding claim 17, applicant argues Ritter does not teach "wherein the indication of sub-carriers is received via a downlink control channel."

Response IV: examiner respectfully disagrees with the argument. Ritter clearly teaches or at least includes teaching about sub-carriers allocation. In Ritter, a base station communicates with a mobile station using signaling/control channel (which is undoubtedly a downlink) (see page 25).

Argument V: regarding claims 29 and 62, applicant asserts that "base station performing sub-carrier allocation --- based on inter-cell interference avoidance and intra-cell traffic load balancing" is not taught by Ritter.

Response V: Ritter discloses or teaches the features of claim 29 except, not explicitly teaching about intra-cell traffic load balancing. As indicated in the body of the rejection of claim 29, Feuerstein teaches about network optimization based on measured local interference and/or local traffic load conditions (see col. 2, lines 27-37). It is to be noted that optimization can include balancing in the sense of Feuerstein's teaching. Thus, the argument is not convincing.

Conclusion

THIS ACTION IS MADE FINAL. Applicant is reminded of the extension of time policy as set forth in 37 CFR 1.136(a).

A shortened statutory period for reply to this final action is set to expire **THREE MONTHS** from the mailing date of this action. In the event a first reply is filed within **TWO MONTHS** of the mailing date of this final action and the advisory action is not mailed until after the end of the **THREE-MONTH** shortened statutory period, then the shortened statutory period will expire on the date the advisory action is mailed, and any extension fee pursuant to 37 CFR 1.136(a) will be calculated from the mailing date of the advisory action. In no event, however, will the statutory period for reply expire later than **SIX MONTHS** from the mailing date of this final action.

Any inquiry concerning this communication or earlier communications from the examiner should be directed to Meless N. Zewdu whose telephone number is (571) 272-7873. The examiner can normally be reached on 8:30 am to 5:00 pm..

If attempts to reach the examiner by telephone are unsuccessful, the examiner's supervisor, Bost Dwayne D can be reached on (571) 272-7023. The fax phone number for the organization where this application or proceeding is assigned is 571-273-8300.

Art Unit: 2617

Information regarding the status of an application may be obtained from the Patent Application Information Retrieval (PAIR) system. Status information for published applications may be obtained from either Private PAIR or Public PAIR. Status information for unpublished applications is available through Private PAIR only. For more information about the PAIR system, see <http://pair-direct.uspto.gov>. Should you have questions on access to the Private PAIR system, contact the Electronic Business Center (EBC) at 866-217-9197 (toll-free). If you would like assistance from a USPTO Customer Service Representative or access to the automated information system, call 800-786-9199 (IN USA OR CANADA) or 571-272-1000.

Any inquiry of a general nature relating to the status of this application or proceeding should be directed to the receptionist whose telephone number is (571) 272-2600.

/Meless N Zewdu/

Primary Examiner, Art Unit 2617

6/3/2008

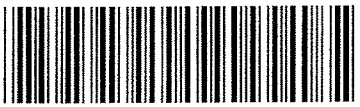
Search Notes 	Application/Control No. 11199586	Applicant(s)/Patent Under Reexamination LI ET AL.
	Examiner Meless N Zewdu	Art Unit 2617

SEARCHED			
Class	Subclass	Date	Examiner

SEARCH NOTES		
Search Notes	Date	Examiner
Search has been updated.	5/29/08	M.Z.

INTERFERENCE SEARCH			
Class	Subclass	Date	Examiner

<i>Index of Claims</i> 	Application/Control No. 11199586	Applicant(s)/Patent Under Reexamination LI ET AL.
	Examiner Meless N Zewdu	Art Unit 2617

✓	Rejected
=	Allowed

-	Cancelled
÷	Restricted

N	Non-Elected
I	Interference

A	Appeal
O	Objected

Claims renumbered in the same order as presented by applicant
 CPA
 T.D.
 R.1.47

CLAIM		DATE									
Final	Original	05/29/2008									
	1	✓									
	2	✓									
	3	✓									
	4	✓									
	5	-									
	6	-									
	7	✓									
	8	✓									
	9	-									
	10	-									
	11	-									
	12	✓									
	13	✓									
	14	✓									
	15	✓									
	16	✓									
	17	✓									
	18	✓									
	19	✓									
	20	✓									
	21	-									
	22	-									
	23	✓									
	24	-									
	25	-									
	26	O									
	27	O									
	28	-									
	29	✓									
	30	✓									
	31	✓									
	32	O									
	33	O									
	34	-									
	35	-									
	36	✓									

Index of Claims 	Application/Control No. 11199586	Applicant(s)/Patent Under Reexamination LI ET AL.
	Examiner Meless N Zewdu	Art Unit 2617

✓	Rejected
=	Allowed

-	Cancelled
÷	Restricted

N	Non-Elected
I	Interference

A	Appeal
O	Objected

Claims renumbered in the same order as presented by applicant
 CPA
 T.D.
 R.1.47

CLAIM		DATE									
Final	Original	05/29/2008									
	37	✓									
	38	-									
	39	-									
	40	-									
	41	-									
	42	-									
	43	✓									
	44	✓									
	45	✓									
	46	✓									
	47	✓									
	48	✓									
	49	✓									
	50	-									
	51	-									
	52	✓									
	53	-									
	54	-									
	55	O									
	56	O									
	57	-									
	58	=									
	59	-									
	60	=									
	61	-									
	62	✓									

Electronic Acknowledgement Receipt

EFS ID:	3724350
Application Number:	11199586
International Application Number:	
Confirmation Number:	1128
Title of Invention:	OFDMA with adaptive subcarrier-cluster configuration and selective loading
First Named Inventor/Applicant Name:	Xiaodong Li
Customer Number:	29053
Filer:	Robert L. Greeson/Carol Martin
Filer Authorized By:	Robert L. Greeson
Attorney Docket Number:	68144/P014C1/10503148
Receipt Date:	04-AUG-2008
Filing Date:	08-AUG-2005
Time Stamp:	15:41:38
Application Type:	Utility under 35 USC 111(a)

Payment information:

Submitted with Payment	no
------------------------	----

File Listing:

Document Number	Document Description	File Name	File Size(Bytes) /Message Digest	Multi Part /.zip	Pages (if appl.)
1		AdaptixP014C1Amdt080408.pdf	461151 <small>a794b806cf97cc8345d9f729ce8486b3585294c4</small>	yes	12

Multipart Description/PDF files in .zip description

Document Description	Start	End
Miscellaneous Incoming Letter	1	1
Amendment After Final	2	2
Claims	3	8
Applicant Arguments/Remarks Made in an Amendment	9	12

Warnings:

Information:

Total Files Size (in bytes):	461151
-------------------------------------	--------

This Acknowledgement Receipt evidences receipt on the noted date by the USPTO of the indicated documents, characterized by the applicant, and including page counts, where applicable. It serves as evidence of receipt similar to a Post Card, as described in MPEP 503.

New Applications Under 35 U.S.C. 111

If a new application is being filed and the application includes the necessary components for a filing date (see 37 CFR 1.53(b)-(d) and MPEP 506), a Filing Receipt (37 CFR 1.54) will be issued in due course and the date shown on this Acknowledgement Receipt will establish the filing date of the application.

National Stage of an International Application under 35 U.S.C. 371

If a timely submission to enter the national stage of an international application is compliant with the conditions of 35 U.S.C. 371 and other applicable requirements a Form PCT/DO/EO/903 indicating acceptance of the application as a national stage submission under 35 U.S.C. 371 will be issued in addition to the Filing Receipt, in due course.

New International Application Filed with the USPTO as a Receiving Office

If a new international application is being filed and the international application includes the necessary components for an international filing date (see PCT Article 11 and MPEP 1810), a Notification of the International Application Number and of the International Filing Date (Form PCT/RO/105) will be issued in due course, subject to prescriptions concerning national security, and the date shown on this Acknowledgement Receipt will establish the international filing date of the application.

IN THE UNITED STATES PATENT AND TRADEMARK OFFICE

In re Patent Application of:
Xiaodong Li et al.

Application No.: 11/199,586

Confirmation No.: 1128

Filed: August 8, 2005

Art Unit: 2617

For: OFDMA WITH ADAPTIVE SUBCARRIER-
CLUSTER CONFIGURATION AND
SELECTIVE LOADING

Examiner: M. N. Zewdu

AMENDMENT AFTER FINAL ACTION UNDER 37 C.F.R. 1.116

MS AF
Commissioner for Patents
P.O. Box 1450
Alexandria, VA 22313-1450

Dear Sir:

INTRODUCTORY COMMENTS

In response to the Office Action dated June 3, 2008, finally rejecting claims 1-4, 7-8, 12-20, 23, 29-31, 36-37, 43-49, 52, and 62, please amend the above-identified U.S. patent application as follows:

Amendments to the Claims are reflected in the listing of claims which begins on page 2 of this paper.

Remarks/Arguments begin on page 8 of this paper.

REMARKS

Claims 1-4, 7, 12-20, 23, 26-27, 30-33, 37, 43-48, 52, 55-56, 58 and 60 remain pending. Independent claims 58 and 60, among others, are indicated as allowable. To that end, independent claims 1 and 30 have been amended to recite the subject matter of claims 7 and 36, respectively, which were each indicated as allowable in the Final Action. As such, these amendments do not add new matter or raise grounds for a new search. Claims 7, 29, 36, 49, and 62 have been canceled. Applicant respectfully requests favorable reconsideration and allowance of the claims in light of the remarks contained herein.

Applicant's Record Under M.P.E.P. § 713.04 of Interview with the Examiner

Applicant's attorney appreciates the Examiner's time and consideration in conducting the telephone interview of July 24, 2008. Applicant respectfully submits the following record of the telephone interview under M.P.E.P. § 713.04.

The following persons participated in the interview: Examiner Meless Zewdu and Applicant's Attorney Robert Greeson (Reg. #52,966).

The 35 U.S.C. §112, first paragraph, rejection of claims 7 and 36 were discussed. Applicant indicated to Examiner portions where the respective limitations are supported in the specification. In view of the discussion, the Examiner and Applicant agreed that a minor amendment would be appropriate to clarify the claim language and make each limitation consistent with the specification. As Applicant understands, Examiner agreed that Applicant's proposed amendment would not raise new issues or support grounds for a new search. As Applicant further understands, amending claim 1 to include subject matter of claim 7 and amending claim 30 to include subject matter of claim 36 would prompt allowance of those claims and their dependents.

Allowable Subject Matter

Claims 7, 26, 27, 32, 33, 36, 55, 56, 58, and 60 have been indicated as containing allowable subject matter. The Examiner indicates that claims 7 and 36 would be allowable if rewritten to overcome the 35 U.S.C. §112, first paragraph rejection and if rewritten in independent form to include all the limitations of the base claim and any intervening claims. *See* Final Action, pg. 2. The Examiner also indicates that claims 26, 27, 32, 33, 55, and 56 are objected to as being dependent upon a rejected base claim, but would be allowable if rewritten in independent form including all of the limitations of the base claim and any intervening claims. As such, claim 1 has been amended to include the subject matter of claim 7, and claim 30 has been amended to include the subject matter of claim 36. Accordingly, each of the independent claims of the present application are in condition for allowance. Moreover, Applicant believes the claims, as drafted, overcome the §112 first paragraph of record.

Claim Objections

Claim 29 has been objected to as containing informalities, i.e., because the status indicator “presently presented” should be “previously presented.” This minor error has been corrected.

Claim 49 has been objected to as containing informalities. Claim 12 has been canceled in order to expedite prosecution.

Claim Rejections 35 U.S.C. § 112

Claims 7 and 36 are rejected under 35 U.S.C. § 112 first paragraph, for failing to comply with the written description requirement. More specifically, the Examiner takes issue with “new feedback information” not being disclosed in the specification. Applicant has amended these claims to recite “updated feedback information.” The amendments are supported at, *e.g.*, pgs 17-19 in the specification as originally filed, and are made for the sake of clarity only.

Double Patenting

Claims 1-4, 7-8, 12-15, 17-20, 22, 26-27, 29-33, 36-37, 43-49, 52, 55-56, and 58-62 are rejected on the ground of nonstatutory obviousness-type double patent as being unpatentable over claims 1-23 of Li et al. (U.S. Patent 6,947,748, hereinafter "Li"). However, in light of the amendments to the independent claims, this rejection is now moot.

Claim Rejections 35 U.S.C. § 102

Claims 1-4, 8, 12-18, 30-31, 37, and 43-47 are rejected under 35 U.S.C. § 102 as being anticipated by Ritter (German Patent DE 19800953, hereinafter "Ritter"). "A claim is anticipated only if each and every element as set forth in the claim is found, either expressly or inherently described, in a single prior art reference," *Verdegaal Bros. v. Union Oil Co. of Cal.*, 814 F.2d 628, 631, 2 U.S.P.Q.2d 1051, 1053 (Fed. Cir. 1987). Applicant notes that in light of the above amendments to the independent claims, the present rejection under 35 U.S.C. §102 is now moot.

Claim Rejections 35 U.S.C. § 103

Claims 19-20, 23, 48, 49, and 52 are rejected under 35 U.S.C. § 103 as being unpatentable over Ritter in view of Chuang et al. (U.S. Pat. 6,052,594, hereinafter "Chuang"). Claims 29 and 62 are rejected under 35 U.S.C. § 103 as being unpatentable over Ritter in view of Feuerstein et al. (U.S. Pat. 6,141,565, hereinafter "Feuerstein"). To establish *prima facie* obviousness of a claimed invention, all the claim limitations must be shown by the prior art. *In re Royka*, 490 F.2d 981, 180 U.S.P.Q. 580 (C.C.P.A. 1974). Applicant notes that in light of the above amendments to the independent claims, the present rejection under 35 U.S.C. §103 is now moot.

Conclusion

In view of the above, Applicant believes the pending application is in condition for allowance. Applicant believes no fee is due with this response. However, if any additional fee is due, or at any time during the pendency of this application, please charge any additional fees required or credit any overpayment to Deposit Account No. 06-2380, under Order No. 68144/P014C1/10503148, from which the undersigned is authorized to draw.

Dated: August 4, 2008

Respectfully submitted,

By Robert L. Greeson

Robert L. Greeson
Registration No.: 52,966
FULBRIGHT & JAWORSKI L.L.P.
2200 Ross Avenue, Suite 2800
Dallas, Texas 75201-2784
214-855-7430
214-855-8200 (Fax)
Attorney for Applicant

Amendment After Final Action Under 37 C.F.R. 1.116

I hereby certify that this paper (along with any paper referred to as being attached or enclosed) is being transmitted via the Office electronic filing system in accordance with § 1.6(a)(4).

Dated: August 4, 2008

Signature: Carol Marth

(Carol Marth)

AMENDMENTS TO THE CLAIMS

1. (Currently Amended) A method for subcarrier selection for a system employing orthogonal frequency division multiple access (OFDMA) comprising:
a subscriber unit measuring channel and interference information for a plurality of subcarriers based on pilot symbols received from a base station;
the subscriber unit selecting a set of candidate subcarriers;
the subscriber unit providing feedback information on the set of candidate subcarriers to the base station; ~~and~~
the subscriber unit receiving an indication of subcarriers of the set of subcarriers selected by the base station for use by the subscriber unit; and
the subscriber unit submitting updated feedback information after being allocated the set of subcarriers to be allocated an updated set of subcarriers and thereafter the subscriber unit receiving another indication of the updated set of subcarriers.

2. (Previously Presented) The method defined in Claim 1 further comprising the subscriber unit sending the indication to the base station.

3. (Previously Presented) The method defined in Claim 2 further comprising sending an indication of the set of subcarriers selected by the base station for use by the subscriber unit.

4. (Previously Presented) The method defined in Claim 3 further comprising the base station selecting subcarriers for the subscriber unit based on inter-cell interference avoidance.

5. (Canceled)

6. (Canceled)

7. (Canceled)

8. (Previously Presented) The method defined in Claim 1 further comprising the subscriber unit using information from pilot symbol periods and data periods to measure channel and interference information.

9. (Canceled)

10. (Canceled)

11. (Canceled)

12. (Original) The method defined in Claim 1 wherein the pilot symbols occupy an entire OFDM frequency bandwidth.

13. (Original) The method defined in Claim 12 wherein at least one other pilot symbol from a different cell transmitted at the same time as the pilot symbols received from the base station collide with each other.

14. (Original) The method defined in Claim 1 further comprising the base station selecting the subcarriers from the set of candidate subcarriers based on additional information available to the base station.

15. (Original) The method defined in Claim 14 wherein the additional information comprises traffic load information on each cluster of subcarriers.

16. (Original) The method defined in Claim 15 wherein the traffic load information is provided by a data buffer in the base station.

17. (Original) The method defined in Claim 1 wherein the indication of subcarriers is received via a downlink control channel.

18. (Original) The method defined in Claim 1 wherein the plurality of subcarriers comprises all subcarriers allocable by a base station.

19. (Previously Presented) The method defined in Claim 1 wherein providing feedback information comprises arbitrarily ordering the set of candidate subcarriers as clusters of subcarriers.

20. (Original) The method defined in Claim 19 wherein arbitrarily order candidate clusters comprise clusters in an order with most desirable candidate clusters being listed first.

21. (Canceled)

22. (Canceled)

23. (Original) The method defined in Claim 1 wherein providing feedback information comprises sequentially ordering candidate clusters.

24. (Canceled)

25. (Canceled)

26. (Previously Presented) The method defined in Claim 1 further comprising:
the base station allocating a first portion of the subcarriers to establish a data link between the base station and the subscriber unit; and then
the base station allocating a second portion of the subcarriers to the subscriber unit to increase communication bandwidth.

27. (Previously Presented) The method defined in Claim 26 wherein the base station allocates the second portion after allocating each subscriber unit in the cell subcarriers to establish a data link between the base station and said each subscriber unit.

28. (Canceled)

29. (Canceled)

30. (Currently Amended) An apparatus comprising:
a plurality of subscriber units in a first cell operable to generate feedback information indicating clusters of subcarriers desired for use by the plurality of subscriber units; and

a first base station in the first cell, the first base station operable to allocate OFDMA subcarriers in clusters to the plurality of subscriber units;

each of said plurality of subscriber units to measure channel and interference information for the plurality of subcarriers based on pilot symbols received from the first base station and at least one of the plurality of subscriber units to select a set of candidate subcarriers from the plurality of subcarriers, and said at least one subscriber unit to provide feedback information on the set of candidate subcarriers to the base station and to receive an indication of subcarriers from the set of subcarriers selected by the first base station for use by the at least one subscriber unit, and wherein the subscriber unit submits updated feedback information after being allocated the set of subscriber units to receive an updated set of subcarriers and thereafter receives another indication of the updated set of subcarriers.

31. (Previously Presented) The apparatus defined in Claim 30 wherein each of the plurality of subscriber units continuously monitors reception of the pilot symbols known to the base station and the plurality of subscriber units and measures signal-plus-interference-to-noise ratio (SINR) of each cluster of subcarriers.

32. (Previously Presented) The apparatus defined in Claim 31 wherein each of the plurality of subscriber units measures inter-cell interference, wherein the at least one subscriber unit selects candidate subcarriers based on the inter-cell interference.

33. (Previously Presented) The apparatus defined in Claim 32 wherein the base station selects subcarriers for the one subscriber unit based on inter-cell interference avoidance.

34. (Canceled)

35. (Canceled)

36. (Canceled)

37. (Previously Presented) The apparatus defined in Claim 30 wherein the at least one subscriber unit uses information from pilot symbol periods and data periods to measure channel and interference information.

38-42. (Canceled)

43. (Original) The apparatus defined in Claim 30 wherein the base station selects the subcarriers from the set of candidate subcarriers based on additional information available to the base station.

44. (Original) The apparatus defined in Claim 43 wherein the additional information comprises traffic load information on each cluster of subcarriers.

45. (Original) The apparatus defined in Claim 44 wherein the traffic load information is provided by a data buffer in the base station.

46. (Previously Presented) The apparatus defined in Claim 30 wherein the indication of subcarriers is received via a downlink control channel between the base station and the at least one subscriber unit.

47. (Original) The apparatus defined in Claim 30 wherein the plurality of subcarriers comprises all subcarriers allocable by a base station.

48. (Previously Presented) The apparatus defined in Claim 30 wherein the plurality of subscriber units provide feedback information that comprises an arbitrarily ordered set of candidate subcarriers as clusters of subcarriers.

49-51. (Canceled)

52. (Original) The apparatus defined in Claim 30 wherein providing feedback information comprises sequentially ordering candidate clusters.

53-54. (Canceled)

55. (Previously Presented) The apparatus defined in Claim 30 wherein the base station allocates a first portion of the subcarriers to establish a data link between the base station and the subscriber unit; and then allocates a second portion of the subcarriers to the subscriber unit to increase communication bandwidth.

56. (Previously Presented) The apparatus defined in Claim 55 wherein the base station allocates the second portion after allocating each subscriber unit in the cell subcarriers to establish a data link between the base station and said each subscriber unit.

57. (Canceled)

58. (Previously Presented) A method comprising:
a base station allocating a first portion of a plurality of subcarriers to establish a data link between the base station and a subscriber unit; and
the base station allocating a second portion of said plurality of subcarriers to the subscriber unit to increase communication bandwidth, wherein the base station allocates the second portion after allocating each subscriber unit in the cell subcarriers to establish a data link between the base station and said each subscriber unit.

59. (Canceled)

60. (Previously Presented) A base station comprising:
means for allocating a first portion of a plurality of subcarriers to establish a data link between the base station and a subscriber unit; and
means for allocating a second portion of said plurality of subcarriers to the subscriber unit to increase communication bandwidth, wherein the base station allocates the second portion after allocating each subscriber unit in the cell subcarriers to establish a data link between the base station and said each subscriber unit.

61. (Canceled)

62. (Canceled)

AMENDMENT TRANSMITTAL LETTER

Docket No.
68144/P014C1/10503148

Application No. 11/199,586-Conf. #1128	Filing Date August 8, 2005	Examiner M. N. Zewdu	Art Unit 2617
---	-------------------------------	-------------------------	------------------

Applicant(s): Xiaodong Li et al.

Invention: OFDMA WITH ADAPTIVE SUBCARRIER-CLUSTER CONFIGURATION AND SELECTIVE LOADING

TO THE COMMISSIONER FOR PATENTS

Transmitted herewith is an amendment in the above-identified application.
The fee has been calculated and is transmitted as shown below.

CLAIMS AS AMENDED						
	Claims Remaining After Amendment	Highest Number Previously Paid	Number Extra Claims Present		Rate	
Total Claims	62	- 82 =	0	x	25.00	0.00
Independent Claims	10	- 10 =	0	x	105.00	0.00
Multiple Dependent Claims (check if applicable) <input type="checkbox"/>						
Other fee (please specify):						
TOTAL ADDITIONAL FEE FOR THIS AMENDMENT:						0.00

- Large Entity Small Entity
- No additional fee is required for this amendment.
- Please charge Deposit Account No. _____ in the amount of \$ _____.
A duplicate copy of this sheet is enclosed.
- A check in the amount of \$ _____ to cover the filing fee is enclosed.
- Payment by credit card. Form PTO-2038 is attached.
- The Director is hereby authorized to charge and credit Deposit Account No. 06-2380
as described below. A duplicate copy of this sheet is enclosed.
- Credit any overpayment.
- Charge any additional filing or application processing fees required under 37 CFR 1.16 and 1.17.



Dated: August 4, 2008

Robert L. Greeson
Attorney/Agent Reg. No.: 52,966

FULBRIGHT & JAWORSKI L.L.P.
2200 Ross Avenue, Suite 2800
Dallas, Texas 75201-2784
(214) 855-7430

Amendment Transmittal

I hereby certify that this paper (along with any paper referred to as being attached or enclosed) is being transmitted via the Office electronic filing system in accordance with § 1.6(a)(4).

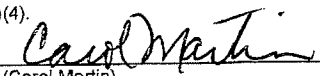
Dated: August 4, 2008 Signature: 
(Carol Martin)

Under the Paperwork Reduction Act of 1995, no persons are required to respond to a collection of information unless it displays a valid OMB control number.

PATENT APPLICATION FEE DETERMINATION RECORD Substitute for Form PTO-875	Application or Docket Number 11/199,586	Filing Date 08/08/2005	<input type="checkbox"/> To be Mailed
---	---	----------------------------------	---------------------------------------

APPLICATION AS FILED – PART I			OTHER THAN				
(Column 1)		(Column 2)	SMALL ENTITY <input checked="" type="checkbox"/>		OR	SMALL ENTITY	
FOR	NUMBER FILED	NUMBER EXTRA	RATE (\$)	FEE (\$)		RATE (\$)	FEE (\$)
<input type="checkbox"/> BASIC FEE <small>(37 CFR 1.16(a), (b), or (c))</small>	N/A	N/A	N/A			N/A	
<input type="checkbox"/> SEARCH FEE <small>(37 CFR 1.16(k), (l), or (m))</small>	N/A	N/A	N/A			N/A	
<input type="checkbox"/> EXAMINATION FEE <small>(37 CFR 1.16(o), (p), or (q))</small>	N/A	N/A	N/A			N/A	
TOTAL CLAIMS <small>(37 CFR 1.16(i))</small>	minus 20 = *	*	X \$ =		OR	X \$ =	
INDEPENDENT CLAIMS <small>(37 CFR 1.16(h))</small>	minus 3 = *	*	X \$ =			X \$ =	
<input type="checkbox"/> APPLICATION SIZE FEE <small>(37 CFR 1.16(s))</small>	If the specification and drawings exceed 100 sheets of paper, the application size fee due is \$250 (\$125 for small entity) for each additional 50 sheets or fraction thereof. See 35 U.S.C. 41(a)(1)(G) and 37 CFR 1.16(s).						
<input type="checkbox"/> MULTIPLE DEPENDENT CLAIM PRESENT <small>(37 CFR 1.16(j))</small>							
* If the difference in column 1 is less than zero, enter "0" in column 2.			TOTAL			TOTAL	

APPLICATION AS AMENDED – PART II					OTHER THAN				
(Column 1)		(Column 2)	(Column 3)	SMALL ENTITY		OR	SMALL ENTITY		
AMENDMENT	08/04/2008	CLAIMS REMAINING AFTER AMENDMENT	HIGHEST NUMBER PREVIOUSLY PAID FOR	PRESENT EXTRA	RATE (\$)	ADDITIONAL FEE (\$)		RATE (\$)	ADDITIONAL FEE (\$)
	Total (37 CFR 1.16(i))	* 62	Minus	** 82	= 0	X \$25 =	0	OR	X \$ =
	Independent (37 CFR 1.16(h))	* 10	Minus	*** 10	= 0	X \$105 =	0	OR	X \$ =
	<input type="checkbox"/> Application Size Fee (37 CFR 1.16(s))								
	<input type="checkbox"/> FIRST PRESENTATION OF MULTIPLE DEPENDENT CLAIM (37 CFR 1.16(j))								
					TOTAL ADD'L FEE	0	OR	TOTAL ADD'L FEE	

APPLICATION AS AMENDED – PART II					OTHER THAN			
(Column 1)		(Column 2)	(Column 3)	SMALL ENTITY		OR	SMALL ENTITY	
AMENDMENT	CLAIMS REMAINING AFTER AMENDMENT	HIGHEST NUMBER PREVIOUSLY PAID FOR	PRESENT EXTRA	RATE (\$)	ADDITIONAL FEE (\$)		RATE (\$)	ADDITIONAL FEE (\$)
	Total (37 CFR 1.16(i))	*	Minus	**	=	X \$ =	OR	X \$ =
	Independent (37 CFR 1.16(h))	*	Minus	***	=	X \$ =	OR	X \$ =
	<input type="checkbox"/> Application Size Fee (37 CFR 1.16(s))							
	<input type="checkbox"/> FIRST PRESENTATION OF MULTIPLE DEPENDENT CLAIM (37 CFR 1.16(j))							
					TOTAL ADD'L FEE		OR	TOTAL ADD'L FEE

* If the entry in column 1 is less than the entry in column 2, write "0" in column 3.
 ** If the "Highest Number Previously Paid For" IN THIS SPACE is less than 20, enter "20".
 *** If the "Highest Number Previously Paid For" IN THIS SPACE is less than 3, enter "3".
 The "Highest Number Previously Paid For" (Total or Independent) is the highest number found in the appropriate box in column 1.

Legal Instrument Examiner:
 /ANTHONY WILLIAMS/

This collection of information is required by 37 CFR 1.16. The information is required to obtain or retain a benefit by the public which is to file (and by the USPTO to process) an application. Confidentiality is governed by 35 U.S.C. 122 and 37 CFR 1.14. This collection is estimated to take 12 minutes to complete, including gathering, preparing, and submitting the completed application form to the USPTO. Time will vary depending upon the individual case. Any comments on the amount of time you require to complete this form and/or suggestions for reducing this burden, should be sent to the Chief Information Officer, U.S. Patent and Trademark Office, U.S. Department of Commerce, P.O. Box 1450, Alexandria, VA 22313-1450. DO NOT SEND FEES OR COMPLETED FORMS TO THIS ADDRESS. **SEND TO: Commissioner for Patents, P.O. Box 1450, Alexandria, VA 22313-1450.**
 If you need assistance in completing the form, call 1-800-PTO-9199 and select option 2.

Docket No.: 68144/P014C1/10503148
(PATENT)

IN THE UNITED STATES PATENT AND TRADEMARK OFFICE

In re Patent Application of:
Xiaodong Li et al.

Application No.: 11/199,586

Confirmation No.: 1128

Filed: August 8, 2005

Art Unit: 2617

For: OFDMA WITH ADAPTIVE SUBCARRIER-
CLUSTER CONFIGURATION AND
SELECTIVE LOADING

Examiner: M. N. Zewdu

AMENDMENT AFTER FINAL ACTION UNDER 37 C.F.R. 1.116

MS AF
Commissioner for Patents
P.O. Box 1450
Alexandria, VA 22313-1450

Dear Sir:

INTRODUCTORY COMMENTS

In response to the Office Action dated June 3, 2008, finally rejecting claims 1-4, 7-8, 12-20, 23, 29-31, 36-37, 43-49, 52, and 62, please amend the above-identified U.S. patent application as follows:

Amendments to the Claims are reflected in the listing of claims which begins on page 2 of this paper.

Remarks/Arguments begin on page 8 of this paper.

EAST Search History

Ref #	Hits	Search Query	DBs	Default Operator	Plurals	Time Stamp
L1	6322213	((("455"/("41.2", 44-45, "63.1-63.2", "67.11", "69", "70" "266", "403", "422.1", 423-425, "443", 446-450, "452.1-452.2", "453", "455", "464", "500", 509-510, "517", 524-526, "550.1", "556.2", "561", "562.1").ccls.) or ("370"/(203-210, 312-314, 319-322, 328-330, "338", 341-344, 346-347, "395.21", "395.41", "430", "437", "447", "449", "458", 461-462, 465-480, "913"). ccls.) oe ("375"/("240", "240.07", "240.11").ccls.)))	US-PGPUB; USPAT; USOCR; EPO; JPO; DERWENT; IBM_TDB	OR	ON	2008/08/18 19:46
L2	78	((XIAODONG) near2 (LI)).INV.	US-PGPUB; USPAT; USOCR	OR	ON	2008/08/18 19:47
L3	2	((HUI) near2 (LUI)).INV.	US-PGPUB; USPAT; USOCR	OR	ON	2008/08/18 19:47
L4	14	((KEMIN) near2 (LI)).INV.	US-PGPUB; USPAT; USOCR	OR	ON	2008/08/18 19:47
L5	56	((WENZHONG) near2 (ZHANG)).INV.	US-PGPUB; USPAT; USOCR	OR	ON	2008/08/18 19:47
L6	0	(Baker adj Communications). AS.	US-PGPUB; USPAT; USOCR; EPO; JPO; DERWENT; IBM_TDB	OR	ON	2008/08/18 19:48
L7	1	(Kaon adj Systems).AS.	US-PGPUB; USPAT; USOCR; EPO; JPO; DERWENT; IBM_TDB	OR	ON	2008/08/18 19:49
L8	0	(SDR adj Holdings).AS.	US-PGPUB; USPAT; USOCR; EPO; JPO; DERWENT; IBM_TDB	OR	ON	2008/08/18 19:50
L9	0	(J&K adj Services).AS.	US-PGPUB; USPAT; USOCR; EPO; JPO; DERWENT; IBM_TDB	OR	ON	2008/08/18 19:51

L10	0	(Adaptix adj "INc.").AS.	US-PGPUB; USPAT; USOCR; EPO; JPO; DERWENT; IBM_TDB	OR	ON	2008/08/18 19:51
L11	0	(Broadstrom adj Telecommunications).AS.	US-PGPUB; USPAT; USOCR; EPO; JPO; DERWENT; IBM_TDB	OR	ON	2008/08/18 19:52
L12	122	2 or 13 or 14 or 15	US-PGPUB; USPAT; USOCR; EPO; JPO; DERWENT; IBM_TDB	OR	ON	2008/08/18 19:52
L13	353	(((report\$3 or feedback) with (new or updat\$3 or second\$3 or periodic\$4)) and (measur\$5 with interference) and (sub- channel or subchannel or sub- carrier or subcarrier) and (allocat\$3 or assign\$4 or request\$3 or select\$3))	US-PGPUB; USPAT; USOCR; EPO; JPO; DERWENT; IBM_TDB	OR	ON	2008/08/18 20:07
L14	223	(((report\$3 or feedback) with (new or updat\$3 or second\$3 or periodic\$4)) and (measur\$5 with interference) and ((plural \$3 or multiple or set or group or cluster) with (sub-channel or subchannel or sub-carrier or subcarrier)) and (allocat\$3 or assign\$4 or request\$3 or select \$3))	US-PGPUB; USPAT; USOCR; EPO; JPO; DERWENT; IBM_TDB	OR	ON	2008/08/18 20:09
L15	223	(((report\$3 or feedback) with (new or another or updat\$3 or second\$3 or periodic\$4)) and (measur\$5 with interference) and ((plural\$3 or multiple or set or group or cluster) with (sub-channel or subchannel or sub-carrier or subcarrier)) and (allocat\$3 or assign\$4 or request\$3 or select\$3))	US-PGPUB; USPAT; USOCR; EPO; JPO; DERWENT; IBM_TDB	OR	ON	2008/08/18 20:09

L16	32	(((report\$3 or feedback) with (new or another or updat\$3 or second\$3 or periodic\$4)) and (measur\$5 with interference) and ((plural\$3 or multiple or set or group or cluster) with (sub-channel or subchannel or sub-carrier or subcarrier)) and (allocat\$3 or assign\$4 or request\$3 or select\$3) and ((pilot near5 symbol) with (base near3 station)))	US-PGPUB; USPAT; USOCR; EPO; JPO; DERWENT; IBM_TDB	OR	ON	2008/08/18 20:10
L17	21	I12 and I16	US-PGPUB; USPAT; USOCR; EPO; JPO; DERWENT; IBM_TDB	OR	ON	2008/08/18 20:21
L18	17	I1 and I16	US-PGPUB; USPAT; USOCR; EPO; JPO; DERWENT; IBM_TDB	OR	ON	2008/08/18 20:22
L19	2	(((report\$3 or feedback) with (new or another or updat\$3 or second\$3 or periodic\$4)) and (measur\$5 with interference) and ((plural\$3 or multiple or set or group or cluster) with (sub-channel or subchannel or sub-carrier or subcarrier)) and (allocat\$3 or assign\$4 or request\$3 or select\$3) and ((pilot near5 symbol) with (base near3 station))).clm.	US-PGPUB; USPAT; USOCR; EPO; JPO; DERWENT; IBM_TDB	OR	ON	2008/08/18 20:23
L21	0	(((("455"/("67.11", "69", "450", "452.2", "464", "509", "550.1", "556.2", "561").ccls.) or ("370"/("328", "329", "338", "341", "344").ccls.)) and ((report\$3 or feedback) with (new or another or updat\$3 or second \$3 or periodic\$4)) and (measur \$5 with interference) and ((plural\$3 or multiple or set or group or cluster) with (sub-channel or subchannel or sub-carrier or subcarrier)) and (allocat\$3 or assign\$4 or request\$3 or select\$3) and ((pilot near5 symbol) with (base near3 station))).clm.	US-PGPUB; USPAT; USOCR; EPO; JPO; DERWENT; IBM_TDB	OR	ON	2008/08/18 20:31

8/18/2008 8:32:16 PM

C:\Documents and Settings\mzewdu\My Documents\EAST\Workspaces\workstation 1.wsp

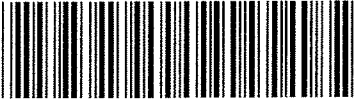
Search Notes 	Application/Control No. 11199586	Applicant(s)/Patent Under Reexamination LI ET AL.
	Examiner Meless N Zewdu	Art Unit 2617

SEARCHED			
Class	Subclass	Date	Examiner
455	41.2, 44-45, 63.1-63.2, 67.11, 69, 70, 266, 403, 422.1, 423-425, 443, 446-450, 452.1-452.2, 453, 455, 464, 500, 509-510, 517, 524-526, 550.1, 556.2, 561, 562.1	8/18/08	M.Z.
370	203-210, 312-314, 319-322, 328-330, 338, 341-344, 346-347, 395.21, 395.41, 430, 437, 447, 449, 458, 461-462, 465-480, 913	8/18/08	M.Z.
375	240, 240.07, 240.11	8/18/08	M.Z.

SEARCH NOTES		
Search Notes	Date	Examiner
Search has been updated.	5/29/08	M.Z.
Searched in EAST: US-PGPUB; USPAT; USOCR; EPO; JPO; DERWENT & IBM_TDB	8/18/08	M.Z.
Searched by: Inventors; Assignee; Class-subclass; Claims (Interference)	8/18/08	M.Z.
For more detail: Please refer to the attached search history.	8/19/08	M.Z.

INTERFERENCE SEARCH			
Class	Subclass	Date	Examiner
455	67.11, 69, 450, 452.2, 464, 509, 550.1, 556.2, 561	8/18/08	M.Z.
370	328, 329, 338, 341, 344	8/18/08	M.Z.

	/Meless N Zewdu/ Primary Examiner.Art Unit 2617
--	--

Issue Classification



Application/Control No.

11199586

Applicant(s)/Patent Under Reexamination

LI ET AL.

Examiner

Meless N Zewdu

Art Unit

2617

ORIGINAL

INTERNATIONAL CLASSIFICATION

CLASS

SUBCLASS

CLAIMED

NON-CLAIMED

455

450

H 0 4 B 17 / 00 (2006.01.01)

CROSS REFERENCE(S)

H 0 4 B 7 / 00 (2006.01.01)

H 0 4 Q 7 / 20 (2006.01.01)

CLASS SUBCLASS (ONE SUBCLASS PER BLOCK)

H 0 4 M 1 / 00 (2006.01.01)

455 67.11 69 452.2 464 509 H 0 4 M 1 / 38 (2006.01.01)

455 550.1 556.2 561 H 0 4 Q 7 / 00 (2006.01.01)

370 329 341 H 0 4 Q 7 / 28 (2006.01.01)

Claims renumbered in the same order as presented by applicant CPA T.D. R.1.47

Final	Original	Final	Original	Final	Original	Final	Original	Final	Original	Final	Original	Final	Original	Final	Original
1	1	11	17	21	33		49								
2	2	12	18		34		50								
3	3	13	19		35		51								
4	4	14	20		36	29	52								
	5		21	22	37		53								
	6		22		38		54								
	7	15	23		39	30	55								
5	8		24		40	31	56								
	9		25		41		57								
	10	16	26		42	32	58								
	11	17	27	23	43		59								
6	12		28	24	44	33	60								
7	13		29	25	45		61								
8	14	18	30	26	46		62								
9	15	19	31	27	47										
10	16	20	32	28	48										

NONE

Total Claims Allowed:

33

(Assistant Examiner)

(Date)

/Meless N Zewdu/
Primary Examiner.Art Unit 2617

08/19/2008

O.G. Print Claim(s)

O.G. Print Figure

(Primary Examiner)

(Date)

1

1B

Index of Claims 	Application/Control No. 11199586	Applicant(s)/Patent Under Reexamination LI ET AL.
	Examiner Meless N Zewdu	Art Unit 2617

✓	Rejected
=	Allowed

-	Cancelled
÷	Restricted

N	Non-Elected
I	Interference

A	Appeal
O	Objected

Claims renumbered in the same order as presented by applicant
 CPA
 T.D.
 R.1.47

CLAIM		DATE							
Final	Original	05/29/2008	08/19/2008						
1	1	✓	=						
2	2	✓	=						
3	3	✓	=						
4	4	✓	=						
	5	-	-						
	6	-	-						
	7	✓	-						
5	8	✓	=						
	9	-	-						
	10	-	-						
	11	-	-						
6	12	✓	=						
7	13	✓	=						
8	14	✓	=						
9	15	✓	=						
10	16	✓	=						
11	17	✓	=						
12	18	✓	=						
13	19	✓	=						
14	20	✓	=						
	21	-	-						
	22	-	-						
15	23	✓	=						
	24	-	-						
	25	-	-						
16	26	O	=						
17	27	O	=						
	28	-	-						
	29	✓	-						
18	30	✓	=						
19	31	✓	=						
20	32	O	=						
21	33	O	=						
	34	-	-						
	35	-	-						
	36	✓	-						

Index of Claims 	Application/Control No. 11199586	Applicant(s)/Patent Under Reexamination LI ET AL.
	Examiner Meless N Zewdu	Art Unit 2617

✓	Rejected
=	Allowed

-	Cancelled
÷	Restricted

N	Non-Elected
I	Interference

A	Appeal
O	Objected

Claims renumbered in the same order as presented by applicant
 CPA
 T.D.
 R.1.47

CLAIM		DATE							
Final	Original	05/29/2008	08/19/2008						
22	37	✓	=						
	38	-	-						
	39	-	-						
	40	-	-						
	41	-	-						
	42	-	-						
23	43	✓	=						
24	44	✓	=						
25	45	✓	=						
26	46	✓	=						
27	47	✓	=						
28	48	✓	=						
	49	✓	-						
	50	-	-						
	51	-	-						
29	52	✓	=						
	53	-	-						
	54	-	-						
30	55	O	=						
31	56	O	=						
	57	-	-						
32	58	=	=						
	59	-	-						
33	60	=	=						
	61	-	-						
	62	✓	-						

Notice of References Cited

Application/Control No. 11/199,586	Applicant(s)/Patent Under Reexamination LI ET AL.	
Examiner Meless N. Zewdu	Art Unit 2617	Page 1 of 1

U.S. PATENT DOCUMENTS

*		Document Number Country Code-Number-Kind Code	Date MM-YYYY	Name	Classification
*	A	US-6,473,467 B1	10-2002	Wallace et al.	375/267
	B	US-			
	C	US-			
	D	US-			
	E	US-			
	F	US-			
	G	US-			
	H	US-			
	I	US-			
	J	US-			
	K	US-			
	L	US-			
	M	US-			

FOREIGN PATENT DOCUMENTS

*		Document Number Country Code-Number-Kind Code	Date MM-YYYY	Country	Name	Classification
	N					
	O					
	P					
	Q					
	R					
	S					
	T					

NON-PATENT DOCUMENTS

*		Include as applicable: Author, Title Date, Publisher, Edition or Volume, Pertinent Pages)
	U	
	V	
	W	
	X	

*A copy of this reference is not being furnished with this Office action. (See MPEP § 707.05(a).)
Dates in MM-YYYY format are publication dates. Classifications may be US or foreign.



NOTICE OF ALLOWANCE AND FEE(S) DUE

29053 7590 08/22/2008

FULBRIGHT & JAWORSKI L.L.P
2200 ROSS AVENUE
SUITE 2800
DALLAS, TX 75201-2784

EXAMINER
ZEWDU, MELESS NMN
ART UNIT PAPER NUMBER
2617

DATE MAILED: 08/22/2008

Table with 5 columns: APPLICATION NO., FILING DATE, FIRST NAMED INVENTOR, ATTORNEY DOCKET NO., CONFIRMATION NO.

11/199,586 08/08/2005 Xiaodong Li 68144/P014C1/10503148 1128

TITLE OF INVENTION: OFDMA WITH ADAPTIVE SUBCARRIER-CLUSTER CONFIGURATION AND SELECTIVE LOADING

Table with 7 columns: APPLN. TYPE, SMALL ENTITY, ISSUE FEE DUE, PUBLICATION FEE DUE, PREV. PAID ISSUE FEE, TOTAL FEE(S) DUE, DATE DUE

nonprovisional YES \$720 \$300 \$0 \$1020 11/24/2008

THE APPLICATION IDENTIFIED ABOVE HAS BEEN EXAMINED AND IS ALLOWED FOR ISSUANCE AS A PATENT. PROSECUTION ON THE MERITS IS CLOSED. THIS NOTICE OF ALLOWANCE IS NOT A GRANT OF PATENT RIGHTS. THIS APPLICATION IS SUBJECT TO WITHDRAWAL FROM ISSUE AT THE INITIATIVE OF THE OFFICE OR UPON PETITION BY THE APPLICANT. SEE 37 CFR 1.313 AND MPEP 1308.

THE ISSUE FEE AND PUBLICATION FEE (IF REQUIRED) MUST BE PAID WITHIN THREE MONTHS FROM THE MAILING DATE OF THIS NOTICE OR THIS APPLICATION SHALL BE REGARDED AS ABANDONED. THIS STATUTORY PERIOD CANNOT BE EXTENDED. SEE 35 U.S.C. 151. THE ISSUE FEE DUE INDICATED ABOVE DOES NOT REFLECT A CREDIT FOR ANY PREVIOUSLY PAID ISSUE FEE IN THIS APPLICATION. IF AN ISSUE FEE HAS PREVIOUSLY BEEN PAID IN THIS APPLICATION (AS SHOWN ABOVE), THE RETURN OF PART B OF THIS FORM WILL BE CONSIDERED A REQUEST TO REAPPLY THE PREVIOUSLY PAID ISSUE FEE TOWARD THE ISSUE FEE NOW DUE.

HOW TO REPLY TO THIS NOTICE:

I. Review the SMALL ENTITY status shown above.

If the SMALL ENTITY is shown as YES, verify your current SMALL ENTITY status:

- A. If the status is the same, pay the TOTAL FEE(S) DUE shown above.
B. If the status above is to be removed, check box 5b on Part B - Fee(s) Transmittal and pay the PUBLICATION FEE (if required) and twice the amount of the ISSUE FEE shown above, or

If the SMALL ENTITY is shown as NO:

- A. Pay TOTAL FEE(S) DUE shown above, or
B. If applicant claimed SMALL ENTITY status before, or is now claiming SMALL ENTITY status, check box 5a on Part B - Fee(s) Transmittal and pay the PUBLICATION FEE (if required) and 1/2 the ISSUE FEE shown above.

II. PART B - FEE(S) TRANSMITTAL, or its equivalent, must be completed and returned to the United States Patent and Trademark Office (USPTO) with your ISSUE FEE and PUBLICATION FEE (if required). If you are charging the fee(s) to your deposit account, section "4b" of Part B - Fee(s) Transmittal should be completed and an extra copy of the form should be submitted. If an equivalent of Part B is filed, a request to reapply a previously paid issue fee must be clearly made, and delays in processing may occur due to the difficulty in recognizing the paper as an equivalent of Part B.

III. All communications regarding this application must give the application number. Please direct all communications prior to issuance to Mail Stop ISSUE FEE unless advised to the contrary.

IMPORTANT REMINDER: Utility patents issuing on applications filed on or after Dec. 12, 1980 may require payment of maintenance fees. It is patentee's responsibility to ensure timely payment of maintenance fees when due.

Complete and send this form, together with applicable fee(s), to: **Mail Stop ISSUE FEE**
Commissioner for Patents
P.O. Box 1450
Alexandria, Virginia 22313-1450
 or **Fax (571)-273-2885**

INSTRUCTIONS: This form should be used for transmitting the ISSUE FEE and PUBLICATION FEE (if required). Blocks 1 through 5 should be completed where appropriate. All further correspondence including the Patent, advance orders and notification of maintenance fees will be mailed to the current correspondence address as indicated unless corrected below or directed otherwise in Block 1. by (a) specifying a new correspondence address; and/or (b) indicating a separate "FEE ADDRESS" for maintenance fee notifications.

CURRENT CORRESPONDENCE ADDRESS (Note: Use Block 1 for any change of address)

29053 7590 08/22/2008

FULBRIGHT & JAWORSKI L.L.P.
 2200 ROSS AVENUE
 SUITE 2800
 DALLAS, TX 75201-2784

Note: A certificate of mailing can only be used for domestic mailings of the Fee(s) Transmittal. This certificate cannot be used for any other accompanying papers. Each additional paper, such as an assignment or formal drawing, must have its own certificate of mailing or transmission.

Certificate of Mailing or Transmission

I hereby certify that this Fee(s) Transmittal is being deposited with the United States Postal Service with sufficient postage for first class mail in an envelope addressed to the Mail Stop ISSUE FEE address above, or being facsimile transmitted to the USPTO (571) 273-2885, on the date indicated below.

(Depositor's name)
(Signature)
(Date)

APPLICATION NO.	FILING DATE	FIRST NAMED INVENTOR	ATTORNEY DOCKET NO.	CONFIRMATION NO.
-----------------	-------------	----------------------	---------------------	------------------

11/199,586 08/08/2005 Xiaodong Li 68144/P014C1/10503148 1128

TITLE OF INVENTION: OFDMA WITH ADAPTIVE SUBCARRIER-CLUSTER CONFIGURATION AND SELECTIVE LOADING

APPLN. TYPE	SMALL ENTITY	ISSUE FEE DUE	PUBLICATION FEE DUE	PREV. PAID ISSUE FEE	TOTAL FEE(S) DUE	DATE DUE
-------------	--------------	---------------	---------------------	----------------------	------------------	----------

nonprovisional YES \$720 \$300 \$0 \$1020 11/24/2008

EXAMINER	ART UNIT	CLASS-SUBCLASS
----------	----------	----------------

ZEWDU, MELESS NMN 2617 455-447000

1. Change of correspondence address or indication of "Fee Address" (37 CFR 1.363).

- Change of correspondence address (or Change of Correspondence Address form PTO/SB/122) attached.
- "Fee Address" indication (or "Fee Address" Indication form PTO/SB/47; Rev 03-02 or more recent) attached. **Use of a Customer Number is required.**

2. For printing on the patent front page, list

- (1) the names of up to 3 registered patent attorneys or agents OR, alternatively, 1 _____
- (2) the name of a single firm (having as a member a registered attorney or agent) and the names of up to 2 registered patent attorneys or agents. If no name is listed, no name will be printed. 2 _____
- 3 _____

3. ASSIGNEE NAME AND RESIDENCE DATA TO BE PRINTED ON THE PATENT (print or type)

PLEASE NOTE: Unless an assignee is identified below, no assignee data will appear on the patent. If an assignee is identified below, the document has been filed for recordation as set forth in 37 CFR 3.11. Completion of this form is NOT a substitute for filing an assignment.

(A) NAME OF ASSIGNEE (B) RESIDENCE: (CITY and STATE OR COUNTRY)

Please check the appropriate assignee category or categories (will not be printed on the patent): Individual Corporation or other private group entity Government

4a. The following fee(s) are submitted:

- Issue Fee
- Publication Fee (No small entity discount permitted)
- Advance Order - # of Copies _____

4b. Payment of Fee(s): (Please first reapply any previously paid issue fee shown above)

- A check is enclosed.
- Payment by credit card. Form PTO-2038 is attached.
- The Director is hereby authorized to charge the required fee(s), any deficiency, or credit any overpayment, to Deposit Account Number _____ (enclose an extra copy of this form).

5. Change in Entity Status (from status indicated above)

- a. Applicant claims SMALL ENTITY status. See 37 CFR 1.27.
- b. Applicant is no longer claiming SMALL ENTITY status. See 37 CFR 1.27(g)(2).

NOTE: The Issue Fee and Publication Fee (if required) will not be accepted from anyone other than the applicant; a registered attorney or agent; or the assignee or other party in interest as shown by the records of the United States Patent and Trademark Office.

Authorized Signature _____

Date _____

Typed or printed name _____

Registration No. _____

This collection of information is required by 37 CFR 1.311. The information is required to obtain or retain a benefit by the public which is to file (and by the USPTO to process) an application. Confidentiality is governed by 35 U.S.C. 122 and 37 CFR 1.14. This collection is estimated to take 12 minutes to complete, including gathering, preparing, and submitting the completed application form to the USPTO. Time will vary depending upon the individual case. Any comments on the amount of time you require to complete this form and/or suggestions for reducing this burden, should be sent to the Chief Information Officer, U.S. Patent and Trademark Office, U.S. Department of Commerce, P.O. Box 1450, Alexandria, Virginia 22313-1450. DO NOT SEND FEES OR COMPLETED FORMS TO THIS ADDRESS. SEND TO: Commissioner for Patents, P.O. Box 1450, Alexandria, Virginia 22313-1450.

Under the Paperwork Reduction Act of 1995, no persons are required to respond to a collection of information unless it displays a valid OMB control number.



UNITED STATES PATENT AND TRADEMARK OFFICE

UNITED STATES DEPARTMENT OF COMMERCE
United States Patent and Trademark Office
Address: COMMISSIONER FOR PATENTS
P.O. Box 1450
Alexandria, Virginia 22313-1450
www.uspto.gov

Table with 5 columns: APPLICATION NO., FILING DATE, FIRST NAMED INVENTOR, ATTORNEY DOCKET NO., CONFIRMATION NO.
11/199,586 08/08/2005 Xiaodong Li 68144/P014C1/10503148 1128

EXAMINER

ZEWDU, MELESS NMN

ART UNIT PAPER NUMBER

2617

DATE MAILED: 08/22/2008

FULBRIGHT & JAWORSKI L.L.P
2200 ROSS AVENUE
SUITE 2800
DALLAS, TX 75201-2784

Determination of Patent Term Adjustment under 35 U.S.C. 154 (b)
(application filed on or after May 29, 2000)

The Patent Term Adjustment to date is 0 day(s). If the issue fee is paid on the date that is three months after the mailing date of this notice and the patent issues on the Tuesday before the date that is 28 weeks (six and a half months) after the mailing date of this notice, the Patent Term Adjustment will be 0 day(s).

If a Continued Prosecution Application (CPA) was filed in the above-identified application, the filing date that determines Patent Term Adjustment is the filing date of the most recent CPA.

Applicant will be able to obtain more detailed information by accessing the Patent Application Information Retrieval (PAIR) WEB site (http://pair.uspto.gov).

Any questions regarding the Patent Term Extension or Adjustment determination should be directed to the Office of Patent Legal Administration at (571)-272-7702. Questions relating to issue and publication fee payments should be directed to the Customer Service Center of the Office of Patent Publication at 1-(888)-786-0101 or (571)-272-4200.

Notice of Allowability

Application No.

11/199,586

Applicant(s)

LI ET AL.

Examiner

Meless N. Zewdu

Art Unit

2617

-- The MAILING DATE of this communication appears on the cover sheet with the correspondence address--

All claims being allowable, PROSECUTION ON THE MERITS IS (OR REMAINS) CLOSED in this application. If not included herewith (or previously mailed), a Notice of Allowance (PTOL-85) or other appropriate communication will be mailed in due course. **THIS NOTICE OF ALLOWABILITY IS NOT A GRANT OF PATENT RIGHTS.** This application is subject to withdrawal from issue at the initiative of the Office or upon petition by the applicant. See 37 CFR 1.313 and MPEP 1308.

- 1. This communication is responsive to 8/4/08.
- 2. The allowed claim(s) is/are 1-4, 8, 12-20, 23, 26-27, 30-33, 37, 43-48, 52, 55-56, 58 and 60.
- 3. Acknowledgment is made of a claim for foreign priority under 35 U.S.C. § 119(a)-(d) or (f).
 - a) All b) Some* c) None of the:
 - 1. Certified copies of the priority documents have been received.
 - 2. Certified copies of the priority documents have been received in Application No. _____.
 - 3. Copies of the certified copies of the priority documents have been received in this national stage application from the International Bureau (PCT Rule 17.2(a)).

* Certified copies not received: _____.

Applicant has THREE MONTHS FROM THE "MAILING DATE" of this communication to file a reply complying with the requirements noted below. Failure to timely comply will result in ABANDONMENT of this application.

THIS THREE-MONTH PERIOD IS NOT EXTENDABLE.

- 4. A SUBSTITUTE OATH OR DECLARATION must be submitted. Note the attached EXAMINER'S AMENDMENT or NOTICE OF INFORMAL PATENT APPLICATION (PTO-152) which gives reason(s) why the oath or declaration is deficient.
 - 5. CORRECTED DRAWINGS (as "replacement sheets") must be submitted.
 - (a) including changes required by the Notice of Draftsperson's Patent Drawing Review (PTO-948) attached
 - 1) hereto or 2) to Paper No./Mail Date _____.
 - (b) including changes required by the attached Examiner's Amendment / Comment or in the Office action of Paper No./Mail Date _____.
- Identifying indicia such as the application number (see 37 CFR 1.84(c)) should be written on the drawings in the front (not the back) of each sheet. Replacement sheet(s) should be labeled as such in the header according to 37 CFR 1.121(d).
- 6. DEPOSIT OF and/or INFORMATION about the deposit of BIOLOGICAL MATERIAL must be submitted. Note the attached Examiner's comment regarding REQUIREMENT FOR THE DEPOSIT OF BIOLOGICAL MATERIAL.

Attachment(s)

- 1. Notice of References Cited (PTO-892)
- 2. Notice of Draftsperson's Patent Drawing Review (PTO-948)
- 3. Information Disclosure Statements (PTO/SB/08), Paper No./Mail Date _____
- 4. Examiner's Comment Regarding Requirement for Deposit of Biological Material
- 5. Notice of Informal Patent Application
- 6. Interview Summary (PTO-413), Paper No./Mail Date _____.
- 7. Examiner's Amendment/Comment
- 8. Examiner's Statement of Reasons for Allowance
- 9. Other _____.

DETAILED ACTION

Response to Amendment

1. This action is in response to the communication filed on 8/4/08.
2. Claims 5-6, 9-11, 21-22, 24-25, 28, 34-35, 38-42, 50-51, 57, 59 and 61 were previously cancelled.
3. Claims 7, 29, 35, 49 and 62 have been canceled in the current amendment.
4. Thus, claims 5-7, 9-11, 21-22, 24-25, 28-29, 34-36, 38-42, 49-51, 53-54, 57, 59 and 61-62 have been cancelled.
5. Claims 1-4, 8, 12-20, 23, 26-27, 30-33, 37, 43-48, 52, 55-56, 58 and 60 are pending in this action and are allowed.
6. In response to the instant amendment all previous claim objections and rejections under 35 U.S.C 35 have been withdrawn.
7. In response to the instant amendment, all nonstatutory double patenting rejections henceforth provided have been withdrawn.

Examiner's Remark/s

On page 8, in the **REMARKS** section of the current response, applicant has indicated that claim 7 is one of the pending claims and left out claim 8 unaccounted. However, the index of the claims shows claim 7 as canceled and claim 8 as pending. Examiner considers this discrepancy as a typographical error and thus considers claim

Art Unit: 2617

7 as has been canceled and claim 8 as pending. In other words, the index of the claims is considered and taken as the overriding presentation of the pending claims.

EXAMINER'S AMENDMENT

An examiner's amendment to the record appears below. Should the changes and/or additions be unacceptable to applicant, an amendment may be filed as provided by 37 CFR 1.312. To ensure consideration of such an amendment, it MUST be submitted no later than the payment of the issue fee.

The application has been amended as follows:

Please amend the claims as follows:

In claim 1, insert a first comma or (,) after the word 'information' on line 10, and a second comma or (,) after the word 'subcarriers' on line 11.

Allowable Subject Matter

Claims 1-4, 8, 12-20, 23, 26-27, 30-33, 37, 43-48, 52, 55-56, 58 and 60 are allowed.

The following is an examiner's statement of reasons for allowance:

As per claim 1-4, 8, 12-20, 23, 26-27, 30-33, 37, 43-48, 52, 55-56, 58 and 60:
the claims are directed to the known area of sub-carrier/sub-channel allocation and/or selection. The prior art of record does not teach or fairly suggest, a base station

Art Unit: 2617

selecting a set of candidate sub-carriers for use by a subscriber unit and sending to the subscriber unit an indication of the selection, and the subscriber unit, after receiving the selected sub-carriers and the selection indication, submitting updated feedback information to be allocated an updated set of sub-carriers and thereafter the subscriber unit receiving another indication of the updated set of sub-carriers, as recited, particularly, in claims 1 and 30; and a base station allocating a first portion of a plurality of sub-carriers to a subscriber unit and allocating a second portion of sub-carriers to the same subscriber unit, after allocating to each subscriber unit in the cell, so as to increase the bandwidth allocated to the same subscriber unit, as recited in claims 58 and 60.

A US patent (US 6,473,467 B1) issued to Wallace et al. and discovered during the update search has been made of the record.

Any comments considered necessary by applicant must be submitted no later than the payment of the issue fee and, to avoid processing delays, should preferably accompany the issue fee. Such submissions should be clearly labeled "Comments on Statement of Reasons for Allowance."

Conclusion

Any inquiry concerning this communication or earlier communications from the examiner should be directed to Meless N. Zewdu whose telephone number is (571) 272-7873. The examiner can normally be reached on 8:30 am to 5:00 pm..

Art Unit: 2617

If attempts to reach the examiner by telephone are unsuccessful, the examiner's supervisor, Bost Dwayne D can be reached on (571) 272-7023. The fax phone number for the organization where this application or proceeding is assigned is 571-273-8300.

Information regarding the status of an application may be obtained from the Patent Application Information Retrieval (PAIR) system. Status information for published applications may be obtained from either Private PAIR or Public PAIR. Status information for unpublished applications is available through Private PAIR only. For more information about the PAIR system, see <http://pair-direct.uspto.gov>. Should you have questions on access to the Private PAIR system, contact the Electronic Business Center (EBC) at 866-217-9197 (toll-free). If you would like assistance from a USPTO Customer Service Representative or access to the automated information system, call 800-786-9199 (IN USA OR CANADA) or 571-272-1000.

Any inquiry of a general nature relating to the status of this application or proceeding should be directed to the receptionist whose telephone number is (571) 272-2600.

/Meless N Zewdu/
Primary Examiner, Art Unit 2617
8/23/2008

IN THE UNITED STATES PATENT AND TRADEMARK OFFICE

In re Patent Application of:
Xiaodong Li et al.

Application No.: 11/199,586

Confirmation No.: 1128

Filed: August 8, 2005

Art Unit: 2617

For: OFDMA WITH ADAPTIVE SUBCARRIER-
CLUSTER CONFIGURATION AND
SELECTIVE LOADING

Examiner: M. N. Zewdu

INFORMATION DISCLOSURE STATEMENT (IDS)

Commissioner for Patents
P.O. Box 1450
Alexandria, VA 22313-1450

Dear Sir:

Pursuant to 37 CFR 1.56, 1.97 and 1.98, the attention of the Patent and Trademark Office is hereby directed to the references listed on the attached PTO/SB/08. It is respectfully requested that the information be expressly considered during the prosecution of this application, and that the references be made of record therein and appear among the "References Cited" on any patent to issue therefrom.

This Information Disclosure Statement is filed after the mailing date of a Final Office Action or Notice of Allowance, whichever occurred first, but on or before payment of the Issue Fee (37 CFR 1.97(d)). Applicant(s) hereby petition(s) that the Information Disclosure Statement be considered.

I hereby certify, pursuant to 37 CFR 1.97(e)(1), that each item of information contained in this Information Disclosure Statement was first cited in any communication from a foreign patent office in a counterpart foreign application not more than three months prior to the filing of this Information Disclosure Statement.

In accordance with 37 CFR 1.98(a)(2)(ii), Applicant has not submitted copies of U.S. patents and U.S. patent applications. Applicant submits herewith copies of foreign patents and non-patent literature in accordance with 37 CFR 1.98(a)(2).

A concise explanation of relevance of the items listed on form PTO/SB/08 is given for only non-English language listed items.

In accordance with 37 CFR 1.97(g), the filing of this Information Disclosure Statement shall not be construed to mean that a search has been made or that no other material information as defined in 37 CFR 1.56(a) exists. In accordance with 37 CFR 1.97(h), the filing of this Information Disclosure Statement shall not be construed to be an admission that any patent, publication or other information referred to therein is "prior art" for this invention unless specifically designated as such.

It is submitted that the Information Disclosure Statement is in compliance with 37 CFR 1.98 and the Examiner is respectfully requested to consider the listed references.

Please charge our Credit Card in the amount of \$180.00 covering the fee set forth in 37 CFR 1.17(p). Credit Card Payment Form SB-2038, with a signature from an authorized cardholder, is enclosed. The Director is hereby authorized to charge any deficiency in the fees filed, asserted to be filed or which should have been filed herewith (or with any paper hereafter filed in this application by this firm) to our Deposit Account No. 06-2380, under Order No. 68144/P014C1/10503148.

Dated: August 26, 2008

Respectfully submitted,

By 

Robert L. Greeson

Registration No.: 52,966

FULBRIGHT & JAWORSKI L.L.P.

2200 Ross Avenue, Suite 2800

Dallas, Texas 75201-2784

(214) 855-7430

(214) 855-8200 (Fax)

Attorney for Applicant

Information Disclosure Statement

I hereby certify that this paper (along with any paper referred to as being attached or enclosed) is being transmitted via the Office electronic filing system in accordance with § 1.6(a)(4).

Dated: August 26, 2008

Signature: 

(Carol Martin)

Electronic Patent Application Fee Transmittal

Application Number:	11199586			
Filing Date:	08-Aug-2005			
Title of Invention:	OFDMA WITH ADAPTIVE SUBCARRIER-CLUSTER CONFIGURATION AND SELECTIVE LOADING			
First Named Inventor/Applicant Name:	Xiaodong Li			
Filer:	Robert L. Greeson/Carol Martin			
Attorney Docket Number:	68144/P014C1/10503148			
Filed as Small Entity				
Utility under 35 USC 111(a) Filing Fees				
Description	Fee Code	Quantity	Amount	Sub-Total in USD(\$)
Basic Filing:				
Pages:				
Claims:				
Miscellaneous-Filing:				
Petition:				
Patent-Appeals-and-Interference:				
Post-Allowance-and-Post-Issuance:				
Extension-of-Time:				

Description	Fee Code	Quantity	Amount	Sub-Total in USD(\$)
Miscellaneous:				
Submission- Information Disclosure Stmt	1806	1	180	180
Total in USD (\$)				180

Electronic Acknowledgement Receipt

EFS ID:	3840226
Application Number:	11199586
International Application Number:	
Confirmation Number:	1128
Title of Invention:	OFDMA WITH ADAPTIVE SUBCARRIER-CLUSTER CONFIGURATION AND SELECTIVE LOADING
First Named Inventor/Applicant Name:	Xiaodong Li
Customer Number:	29053
Filer:	Robert L. Greeson/Carol Martin
Filer Authorized By:	Robert L. Greeson
Attorney Docket Number:	68144/P014C1/10503148
Receipt Date:	26-AUG-2008
Filing Date:	08-AUG-2005
Time Stamp:	14:27:35
Application Type:	Utility under 35 USC 111(a)

Payment information:

Submitted with Payment	yes
Payment Type	Credit Card
Payment was successfully received in RAM	\$ 180
RAM confirmation Number	8163
Deposit Account	
Authorized User	

File Listing:

Document Number	Document Description	File Name Page 586	File Size(Bytes)/ Message Digest	Multi Part /.zip	Pages (if appl.)
-----------------	----------------------	-----------------------	-------------------------------------	------------------	------------------

1		Adap10503148.pdf	149562 67a3f70b13f126bfe880839bb0b5574ce0557b44	yes	3
Multipart Description/PDF files in .zip description					
		Document Description	Start	End	
		Information Disclosure Statement Letter	1	2	
		Information Disclosure Statement (IDS) Filed (SB/08)	3	3	
Warnings:					
Information:					
2	Fee Worksheet (PTO-06)	fee-info.pdf	30572 beab3343499fc1d1ba993ddb6fda1830d3b4e2794	no	2
Warnings:					
Information:					
Total Files Size (in bytes):			180134		
<p>This Acknowledgement Receipt evidences receipt on the noted date by the USPTO of the indicated documents, characterized by the applicant, and including page counts, where applicable. It serves as evidence of receipt similar to a Post Card, as described in MPEP 503.</p> <p><u>New Applications Under 35 U.S.C. 111</u> If a new application is being filed and the application includes the necessary components for a filing date (see 37 CFR 1.53(b)-(d) and MPEP 506), a Filing Receipt (37 CFR 1.54) will be issued in due course and the date shown on this Acknowledgement Receipt will establish the filing date of the application.</p> <p><u>National Stage of an International Application under 35 U.S.C. 371</u> If a timely submission to enter the national stage of an international application is compliant with the conditions of 35 U.S.C. 371 and other applicable requirements a Form PCT/DO/EO/903 indicating acceptance of the application as a national stage submission under 35 U.S.C. 371 will be issued in addition to the Filing Receipt, in due course.</p> <p><u>New International Application Filed with the USPTO as a Receiving Office</u> If a new international application is being filed and the international application includes the necessary components for an international filing date (see PCT Article 11 and MPEP 1810), a Notification of the International Application Number and of the International Filing Date (Form PCT/RO/105) will be issued in due course, subject to prescriptions concerning national security, and the date shown on this Acknowledgement Receipt will establish the international filing date of the application.</p>					

Under the Paperwork Reduction Act of 1995, no persons are required to respond to a collection of information unless it contains a valid OMB control number.

Substitute for form 1449/PTO INFORMATION DISCLOSURE STATEMENT BY APPLICANT (Use as many sheets as necessary)				Complete if Known		
				Application Number	11/199,586-Conf. #1128	
Sheet		1	of	1	Attorney Docket Number	68144/P014C1/10503148

U.S. PATENT DOCUMENTS						
Examiner Initials*	Cite No. ¹	Document Number		Publication Date MM-DD-YYYY	Name of Patentee or Applicant of Cited Document	Pages, Columns, Lines, Where Relevant Passages or Relevant Figures Appear
		Number-Kind Code ² (if known)				
	AA*	US-6,052,594		04-18-2000	Chuang et al.	
	AB*	US-6,526,281		02-25-2003	Gorsuch et al.	
	AC*	US-6,985,432		01-10-2006	Hadad et al.	
	AD*	US-7,373,151		05-13-2008	Ahmed	
	AE*	US-7,047,011		05-16-2006	Wikman et al.	
	AF*	US-6,411,186		06-25-2002	Lilleberg et al.	
	AG*	US-4,670,889		06-02-1987	Hewitt et al.	
	AH*	US-5,839,074		11-17-1998	Plehn et al.	
	AI*	US-6,415,153		07-02-2002	Liew	
	AJ*	US-6,920,122		07-19-2005	Hanaoka et al.	
	AK	US-5,437,054		07-25-1995	Rappaport et al.	
	AL	US-6,023,622		02-08-2000	Plaschke et al.	

FOREIGN PATENT DOCUMENTS							
Examiner Initials*	Cite No. ¹	Foreign Patent Document		Publication Date MM-DD-YYYY	Name of Patentee or Applicant of Cited Document	Pages, Columns, Lines, Where Relevant Passages Or Relevant Figures Appear	T ⁶
		Country Code ³ -Number ⁴ -Kind Code ⁵ (if known)					

Examiner Signature	Date Considered
--------------------	-----------------

*EXAMINER: Initial if reference considered, whether or not citation is in conformance with MPEP 609. Draw line through citation if not in conformance and not considered. Include copy of this form with next communication to applicant. * CITE NO.: Those application(s) which are marked with an asterisk (*) next to the Cite No. are not supplied (under 37 CFR 1.98(a)(2)(iii)) because that application was filed after June 30, 2003 or is available in the IFW. ¹ Applicant's unique citation designation number (optional). ² See Kinds Codes of USPTO Patent Documents at www.uspto.gov or MPEP 901.04. ³ Enter Office that issued the document, by the two-letter code (WIPO Standard ST.3). ⁴ For Japanese patent documents, the indication of the year of the reign of the Emperor must precede the serial number of the patent document. ⁵ Kind of document by the appropriate symbols as indicated on the document under WIPO Standard ST.16 if possible. ⁶ Applicant is to place a check mark here if English language Translation is attached.

IDS (Citation) by Applicant (12 References) I hereby certify that this paper (along with any paper referred to as being attached or enclosed) is being transmitted via the Office electronic filing system in accordance with § 1.6(a)(4). Dated: August 26, 2008 Signature: <u>Carol Martin</u> (Carol Martin)	
---	--

EAST Search History

Ref #	Hits	Search Query	DBs	Default Operator	Plurals	Time Stamp
L1	24	("6052594", "6526281", "6985432", "7373151", "7047011", "6411186", "4670889", "5839074", "6415153", "6920122", "5437054", "6023622"). pn.	US-PGPUB; USPAT; USOCR; EPO; JPO; DERWENT; IBM_TDB	OR	ON	2008/09/03 17:17
L2	4224	((assign\$3 or allocat\$3 or select\$3 or receiv\$3 or reception or request \$3) with ((subcarrier? or subchannel? or sub-channel? or sub-carrier?) with (candidate or set or multiple or plural\$3 or cluster or group)))	US-PGPUB; USPAT; USOCR; EPO; JPO; DERWENT; IBM_TDB	OR	ON	2008/09/03 17:20
L3	846	l2 and (indicat\$3 near7 (select\$3 or assign\$5 or allocat\$3))	US-PGPUB; USPAT; USOCR; EPO; JPO; DERWENT; IBM_TDB	OR	ON	2008/09/03 17:21
L4	266	l3 and ((feedback or report\$3) with (allocat\$3 or assign\$5 or select\$3))	US-PGPUB; USPAT; USOCR; EPO; JPO; DERWENT; IBM_TDB	OR	ON	2008/09/03 17:23
L5	0	l1 and l4	US-PGPUB; USPAT; USOCR; EPO; JPO; DERWENT; IBM_TDB	OR	ON	2008/09/03 17:23
L6	338967	((("370"/\$.ccls.) or ("375"/\$.ccls.) or ("455"/\$.ccls.))	US-PGPUB; USPAT; USOCR; EPO; JPO; DERWENT; IBM_TDB	OR	ON	2008/09/03 17:24
L7	259	l4 and l6	US-PGPUB; USPAT; USOCR; EPO; JPO; DERWENT; IBM_TDB	OR	ON	2008/09/03 17:24
L8	24	l7 and ((pilot near5 symbol) with (interference near7 (measur\$5 or determin \$5)))	US-PGPUB; USPAT; USOCR; EPO; JPO; DERWENT; IBM_TDB	OR	ON	2008/09/03 17:27

L9	0	l1 and l8	US-PGPUB; USPAT; USOCR; EPO; JPO; DERWENT; IBM_TDB	OR	ON	2008/09/03 17:27
L10	24	l8 and (OFDMA or orthognal or OFDM)	US-PGPUB; USPAT; USOCR; EPO; JPO; DERWENT; IBM_TDB	OR	ON	2008/09/03 17:28
L11	1633	((assign\$3 or allocat\$3 or select\$3 or receiv\$3 or reception or request \$3) with ((subcarrier? or subchannel? or sub- channel? or sub- carrier?) with (candidate or set or multiple or plural\$3 or cluster or group))).clm.	US-PGPUB; USPAT; USOCR; EPO; JPO; DERWENT; IBM_TDB	OR	ON	2008/09/03 17:29
L12	1	l1 and l11	US-PGPUB; USPAT; USOCR; EPO; JPO; DERWENT; IBM_TDB	OR	ON	2008/09/03 17:29
S1	39	("5440542", "5991285", "6266321", "6341125", "6707859", "6747963", "6813506", "6816507", "6868075", "6985471", "6987778", "7088700", "7177345", "7180874", "7200126", "7324565", "20020141436", "20030103473", "20040100918").pn.	US-PGPUB; USPAT; USOCR; EPO; JPO; DERWENT; IBM_TDB	OR	ON	2008/05/21 12:02
S2	463	((combin\$5 or multiplex \$3 or aggregat\$3) with (information near6 (data adj rate)))	US-PGPUB; USPAT; USOCR; EPO; JPO; DERWENT; IBM_TDB	OR	ON	2008/05/21 12:10
S3	4	((combin\$5 or multiplex \$3 or aggregat\$3) with (set near9 (bit near8 (indicat\$3 near7 (data adj rate))))))	US-PGPUB; USPAT; USOCR; EPO; JPO; DERWENT; IBM_TDB	OR	ON	2008/05/21 12:13
S4	833	((combin\$5 or multiplex \$3 or aggregat\$3) with ((bit or indicat\$3) near6 (data adj rate)))	US-PGPUB; USPAT; USOCR; EPO; JPO; DERWENT; IBM_TDB	OR	ON	2008/05/21 12:21

S5	1207	S2 or S3 or S4	US-PGPUB; USPAT; USOCR; EPO; JPO; DERWENT; IBM_TDB	OR	ON	2008/05/21 12:22
S6	156573	((single or one) near9 ((signal\$3 or control\$4) near5 (frame or slot or channel)))	US-PGPUB; USPAT; USOCR; EPO; JPO; DERWENT; IBM_TDB	OR	ON	2008/05/21 12:24
S7	5164	S6 same ((parallel or multiple or plural\$3 or two or three or several) near9 (data near5 channel))	US-PGPUB; USPAT; USOCR; EPO; JPO; DERWENT; IBM_TDB	OR	ON	2008/05/21 12:25
S8	11	S5 same S7	US-PGPUB; USPAT; USOCR; EPO; JPO; DERWENT; IBM_TDB	OR	ON	2008/05/21 12:26
S9	69	S5 and S7	US-PGPUB; USPAT; USOCR; EPO; JPO; DERWENT; IBM_TDB	OR	ON	2008/05/21 12:26
S10	0	S1 and S9	US-PGPUB; USPAT; USOCR; EPO; JPO; DERWENT; IBM_TDB	OR	ON	2008/05/21 12:26
S11	346738	"370"/("211", "235", "265", "310", 313-314, "321", 326-327, 335- 338, "345", "347", "349", "389", "391", 393- 394, "436", "442", "458", "471", "474", "477", 521-522, "535", "537").ccls.	US-PGPUB; USPAT; USOCR; EPO; JPO; DERWENT; IBM_TDB	OR	ON	2008/05/21 12:36
S12	241754	"455"/("59", "61", "403", "414.4", 424-425, "434", "450", "452.2", "464", "466", "509", 515-517, "550.1", "556.2", "561"). ccls.	US-PGPUB; USPAT; USOCR; EPO; JPO; DERWENT; IBM_TDB	OR	ON	2008/05/21 12:37
S13	531187	S11 or S12	US-PGPUB; USPAT; USOCR; EPO; JPO; DERWENT; IBM_TDB	OR	ON	2008/05/21 12:38

S14	2539	(Qualcomm adj Incorporated).AS.	US-PGPUB; USPAT; USOCR; EPO; JPO; DERWENT; IBM_TDB	OR	ON	2008/05/21 12:38
S15	9	(Malladi-Durga).in.	US-PGPUB; USPAT; USOCR; EPO; JPO; DERWENT; IBM_TDB	OR	ON	2008/05/21 12:39
S16	114	(Willenegger-Serge).IN.	US-PGPUB; USPAT; USOCR; EPO; JPO; DERWENT; IBM_TDB	OR	ON	2008/05/21 12:39
S17	11	(Zhang-Xiaoxia).IN.	US-PGPUB; USPAT; USOCR; EPO; JPO; DERWENT; IBM_TDB	OR	ON	2008/05/21 12:40
S18	130	S15 or S16 or S17	US-PGPUB; USPAT; USOCR; EPO; JPO; DERWENT; IBM_TDB	OR	ON	2008/05/21 12:41
S19	34	S9 and S13	US-PGPUB; USPAT; USOCR; EPO; JPO; DERWENT; IBM_TDB	OR	ON	2008/05/21 12:41
S20	3	S9 and S14	US-PGPUB; USPAT; USOCR; EPO; JPO; DERWENT; IBM_TDB	OR	ON	2008/05/21 12:57
S21	3	S9 and S18	US-PGPUB; USPAT; USOCR; EPO; JPO; DERWENT; IBM_TDB	OR	ON	2008/05/21 12:58
S22	531187	((("370"/("314", "328", 337-338, 334-345).ccls.) or ("455"/("434", "450", "509", "550.1", "556.2", "561").ccls.)))	US-PGPUB; USPAT; USOCR; EPO; JPO; DERWENT; IBM_TDB	OR	ON	2008/05/21 13:06

S23	12701	((single or one) and (control or signal\$3) and (channel or frame or slot) and (combin\$5 or aggregat\$3 or multiplex \$3) and ((data near3 rate) near7 (TFCI or indicat\$3 or information or bit)) and ((multiple or plural\$3 or first or second or supplement \$3) with (data near7 (frame or channel))))	US-PGPUB; USPAT; USOCR; EPO; JPO; DERWENT; IBM_TDB	OR	ON	2008/05/21 13:12
S24	10356	((single or one) and (control or signal\$3) and (channel or frame or slot) and (combin\$5 or aggregat\$3 or multiplex \$3) and ((data near3 rate) near7 (TFCI or indicat\$3 or information or bit)) and (encod\$3 or decod\$3) and ((multiple or plural\$3 or first or second or supplement \$3) with (data near7 (frame or channel))))	US-PGPUB; USPAT; USOCR; EPO; JPO; DERWENT; IBM_TDB	OR	ON	2008/05/21 13:14
S25	244	((single or one) and (control or signal\$3) and (channel or frame or slot) and (combin\$5 or aggregat\$3 or multiplex \$3) and ((data near3 rate) near7 (TFCI or indicat\$3 or information or bit)) and (encod\$3 or decod\$3) and ((multiple or plural\$3 or first or second or supplement \$3) with (data near7 (frame or channel))))). clm.	US-PGPUB; USPAT; USOCR; EPO; JPO; DERWENT; IBM_TDB	OR	ON	2008/05/21 13:15
S26	0	(S22 and (single or one) and (control or signal\$3) and (channel or frame or slot) and (combin\$5 or aggregat\$3 or multiplex\$3) and ((data near3 rate) near7 (TFCI or indicat\$3 or information or bit)) and (encod\$3 or decod\$3) and ((multiple or plural \$3 or first or second or supplement\$3) with	US-PGPUB; USPAT; USOCR; EPO; JPO; DERWENT; IBM_TDB	OR	ON	2008/05/21 13:16

		((data near7 (frame or channel))))).clm.				
S27	212	((single or one) and ((control or signal\$3) with (channel or frame or slot)) and ((combin\$5 or aggregat\$3 or multiplex\$3) and ((data near3 rate) near7 (TFCl or indicat\$3 or informati or bit)) and (encod\$3 or decod\$3) and ((multiple or plural \$3 or first or second or supplement\$3) with (data near7 (frame or channel))))).clm.	US-PGPUB; USPAT; USOCR; EPO; JPO; DERWENT; IBM_TDB	OR	ON	2008/05/21 13:17
S28	73	((single or one) and ((control or signal\$3) with (channel or frame or slot)) and ((combin\$5 or aggregat\$3 or multiplex\$3) same ((data near3 rate) near7 (TFCl or indicat\$3 or informati or bit))) and (encod\$3 or decod\$3) and ((multiple or plural \$3 or first or second or supplement\$3) with (data near7 (frame or channel))))).clm.	US-PGPUB; USPAT; USOCR; EPO; JPO; DERWENT; IBM_TDB	OR	ON	2008/05/21 13:18
S29	41	((single or one) and ((control or signal\$3) with (channel or frame or slot)) and ((combin\$5 or aggregat\$3 or multiplex\$3) same ((data near3 rate) near7 (TFCl or indicat\$3 or informati or bit))) and ((encod\$3 or decod\$3) same ((multiple or plural \$3 or first or second or supplement\$3) with (data near7 (frame or channel))))).clm.	US-PGPUB; USPAT; USOCR; EPO; JPO; DERWENT; IBM_TDB	OR	ON	2008/05/21 13:20
S30	2	"20050169211"	US-PGPUB; USPAT; USOCR; EPO; JPO; DERWENT; IBM_TDB	OR	ON	2008/05/21 13:50

S31	0	S30 and (computer near3 (product or program))	US-PGPUB; USPAT; USOCR; EPO; JPO; DERWENT; IBM_TDB	OR	ON	2008/05/21 13:50
S32	0	S30 and (computer near3 (product or program\$4))	US-PGPUB; USPAT; USOCR; EPO; JPO; DERWENT; IBM_TDB	OR	ON	2008/05/21 13:50
S33	1	S30 and (product or program\$4)	US-PGPUB; USPAT; USOCR; EPO; JPO; DERWENT; IBM_TDB	OR	ON	2008/05/21 13:52
S34	0	S30 and product	US-PGPUB; USPAT; USOCR; EPO; JPO; DERWENT; IBM_TDB	OR	ON	2008/05/21 13:53
S35	15556	list\$3 near9 (priority or prioritized)	US-PGPUB; USPAT; USOCR; EPO; JPO; DERWENT; IBM_TDB	OR	ON	2008/07/01 17:46
S36	7	WiFi with S35	US-PGPUB; USPAT; USOCR; EPO; JPO; DERWENT; IBM_TDB	OR	ON	2008/07/01 17:46
S37	20087	wireless near5 (access adj point)	US-PGPUB; USPAT; USOCR; EPO; JPO; DERWENT; IBM_TDB	OR	ON	2008/07/01 18:01
S38	1549	fixed near5 (access adj point)	US-PGPUB; USPAT; USOCR; EPO; JPO; DERWENT; IBM_TDB	OR	ON	2008/07/01 18:01
S39	912	S37 and S38	US-PGPUB; USPAT; USOCR; EPO; JPO; DERWENT; IBM_TDB	OR	ON	2008/07/01 18:01
S40	5	S39 and (access\$3 near7 ((list\$3 or table near6 (priority or prioritized)))	US-PGPUB; USPAT; USOCR; EPO; JPO; DERWENT; IBM_TDB	OR	ON	2008/07/01 18:02

S41	7318	(access adj point) near5 (mobile or portable)	US-PGPUB; USPAT; USOCR; EPO; JPO; DERWENT; IBM_TDB	OR	ON	2008/07/01 18:09
S42	1858	(access adj point) near5 (fixed or stationary)	US-PGPUB; USPAT; USOCR; EPO; JPO; DERWENT; IBM_TDB	OR	ON	2008/07/01 18:10
S43	909	S41 and S42	US-PGPUB; USPAT; USOCR; EPO; JPO; DERWENT; IBM_TDB	OR	ON	2008/07/01 18:10
S44	128	S43 and (terminal near5 (LAN or WLAN))	US-PGPUB; USPAT; USOCR; EPO; JPO; DERWENT; IBM_TDB	OR	ON	2008/07/01 18:10
S45	6	S44 and ((list or table) near7 (priority or prioritized))	US-PGPUB; USPAT; USOCR; EPO; JPO; DERWENT; IBM_TDB	OR	ON	2008/07/01 18:11
S46	369553	(\$4phone near3 (mobile or cellular))	US-PGPUB; USPAT; USOCR; EPO; JPO; DERWENT; IBM_TDB	OR	ON	2008/07/01 18:14
S47	0	S46 with ("operate as access point")	US-PGPUB; USPAT; USOCR; EPO; JPO; DERWENT; IBM_TDB	OR	ON	2008/07/01 18:15
S48	0	S46 with ("operates as access point")	US-PGPUB; USPAT; USOCR; EPO; JPO; DERWENT; IBM_TDB	OR	ON	2008/07/01 18:15
S49	0	S46 with ("operating as access point")	US-PGPUB; USPAT; USOCR; EPO; JPO; DERWENT; IBM_TDB	OR	ON	2008/07/01 18:15
S50	0	("operating as access point")	US-PGPUB; USPAT; USOCR; EPO; JPO; DERWENT; IBM_TDB	OR	ON	2008/07/01 18:16

S51	0	("operates as access point")	US-PGPUB; USPAT; USOCR; EPO; JPO; DERWENT; IBM_TDB	OR	ON	2008/07/01 18:16
S52	0	("functions as access point")	US-PGPUB; USPAT; USOCR; EPO; JPO; DERWENT; IBM_TDB	OR	ON	2008/07/01 18:16
S53	572	("functions access point")	US-PGPUB; USPAT; USOCR; EPO; JPO; DERWENT; IBM_TDB	OR	ON	2008/07/01 18:17
S54	1	S46 with S53	US-PGPUB; USPAT; USOCR; EPO; JPO; DERWENT; IBM_TDB	OR	ON	2008/07/01 18:17
S55	393	((personal adj computer) or laptop or pda) and ((mobile or portable) near3 (access adj point)) and ((fixed or stationary) near4 (access adj point))	US-PGPUB; USPAT; USOCR; EPO; JPO; DERWENT; IBM_TDB	OR	ON	2008/07/01 18:20
S56	6	((personal adj computer) or laptop or pda) and ((mobile or portable) near3 (access adj point)) and ((fixed or stationary) near4 (access adj point)) and ((list\$3 or table) near5 (prioritized or priority)) and (access near7 internet)	US-PGPUB; USPAT; USOCR; EPO; JPO; DERWENT; IBM_TDB	OR	ON	2008/07/01 18:21
S57	6	(private near5 network) near6 (higher near3 priority)	US-PGPUB; USPAT; USOCR; EPO; JPO; DERWENT; IBM_TDB	OR	ON	2008/07/01 18:36
S58	371	gprs near3 modem	US-PGPUB; USPAT; USOCR; EPO; JPO; DERWENT; IBM_TDB	OR	ON	2008/07/01 18:51
S59	144	S46 with S58	US-PGPUB; USPAT; USOCR; EPO; JPO; DERWENT; IBM_TDB	OR	ON	2008/07/01 18:52

S60	9	S59 same (cellular near5 modem)	US-PGPUB; USPAT; USOCR; EPO; JPO; DERWENT; IBM_TDB	OR	ON	2008/07/01 18:52
S61	3644	(plural\$3 or multiple) near7 ((wireless or mobile) near5 (access adj point))	US-PGPUB; USPAT; USOCR; EPO; JPO; DERWENT; IBM_TDB	OR	ON	2008/07/01 18:56
S62	1	S61 same (difference near5 priorit\$3)	US-PGPUB; USPAT; USOCR; EPO; JPO; DERWENT; IBM_TDB	OR	ON	2008/07/01 18:56
S63	0	(comput\$3 near5 device) near9 ((priority or prioritized) near7 (access adj point))	US-PGPUB; USPAT; USOCR; EPO; JPO; DERWENT; IBM_TDB	OR	ON	2008/07/01 19:07
S64	3	(comput\$3 near5 device) near9 ((priority or prioritized) near7 (access adj point))	US-PGPUB; USPAT; USOCR; EPO; JPO; DERWENT; IBM_TDB	OR	ON	2008/07/01 19:08
S65	218	(control near3 frame) with (slot? near4 (multiple or plural\$3 or two))	US-PGPUB; USPAT; USOCR; EPO; JPO; DERWENT; IBM_TDB	OR	ON	2008/07/06 12:34
S66	155	different near5 (slot near3 format)	US-PGPUB; USPAT; USOCR; EPO; JPO; DERWENT; IBM_TDB	OR	ON	2008/07/06 12:35
S67	11204	different near7 (number near3 bit)	US-PGPUB; USPAT; USOCR; EPO; JPO; DERWENT; IBM_TDB	OR	ON	2008/07/06 12:36
S68	16	S66 and S67	US-PGPUB; USPAT; USOCR; EPO; JPO; DERWENT; IBM_TDB	OR	ON	2008/07/06 12:36
S69	1	S65 and S68	US-PGPUB; USPAT; USOCR; EPO; JPO; DERWENT; IBM_TDB	OR	ON	2008/07/06 12:37

S70	1	S65 and S66 and S67	US-PGPUB; USPAT; USOCR; EPO; JPO; DERWENT; IBM_TDB	OR	ON	2008/07/06 12:37
S71	3	S65 and S67	US-PGPUB; USPAT; USOCR; EPO; JPO; DERWENT; IBM_TDB	OR	ON	2008/07/06 12:37
S72	14	TFCI with (different near7 (number near3 bit))	US-PGPUB; USPAT; USOCR; EPO; JPO; DERWENT; IBM_TDB	OR	ON	2008/07/06 12:39
S73	1	S65 and S72	US-PGPUB; USPAT; USOCR; EPO; JPO; DERWENT; IBM_TDB	OR	ON	2008/07/06 12:46
S74	3	S72 and (control near5 frame)	US-PGPUB; USPAT; USOCR; EPO; JPO; DERWENT; IBM_TDB	OR	ON	2008/07/06 12:46
S75	5807	dedicated near5 (control near3 channel)	US-PGPUB; USPAT; USOCR; EPO; JPO; DERWENT; IBM_TDB	OR	ON	2008/07/06 13:10
S76	141	(control near3 frame) near9 S75	US-PGPUB; USPAT; USOCR; EPO; JPO; DERWENT; IBM_TDB	OR	ON	2008/07/06 13:10
S77	0	S76 same (different near7 (slot near3 format))	US-PGPUB; USPAT; USOCR; EPO; JPO; DERWENT; IBM_TDB	OR	ON	2008/07/06 13:11
S78	1	S76 and (different near7 (slot near3 format))	US-PGPUB; USPAT; USOCR; EPO; JPO; DERWENT; IBM_TDB	OR	ON	2008/07/06 13:11
S79	10	((control near5 frame) and (dedicated near7 (control near3 channel)) and (different near7 (slot near3 format)))	US-PGPUB; USPAT; USOCR; EPO; JPO; DERWENT; IBM_TDB	OR	ON	2008/07/06 13:12

S80	45	((control adj frame) and (slot? near3 (plural\$3 or multiple or two)) and (dedicated near5 (control near3 channel)))	US-PGPUB; USPAT; USOCR; EPO; JPO; DERWENT; IBM_TDB	OR	ON	2008/07/06 13:23
S81	62698	((control adj frame) and (slot? near3 (plural\$3 or multiple or two)) and (dedicated near5 (control near3 channel)) (different near4 format))	US-PGPUB; USPAT; USOCR; EPO; JPO; DERWENT; IBM_TDB	OR	ON	2008/07/06 13:24
S82	6	((control adj frame) and (slot? near3 (plural\$3 or multiple or two)) and (dedicated near5 (control near3 channel)) and (different near4 format))	US-PGPUB; USPAT; USOCR; EPO; JPO; DERWENT; IBM_TDB	OR	ON	2008/07/06 13:24
S83	187	((control near3 frame) with (dedicated near3 channel))	US-PGPUB; USPAT; USOCR; EPO; JPO; DERWENT; IBM_TDB	OR	ON	2008/07/06 13:33
S84	0	S83 same (different near7 (slot near3 format))	US-PGPUB; USPAT; USOCR; EPO; JPO; DERWENT; IBM_TDB	OR	ON	2008/07/06 13:34
S85	2	S83 and (different near7 (slot near3 format))	US-PGPUB; USPAT; USOCR; EPO; JPO; DERWENT; IBM_TDB	OR	ON	2008/07/06 13:34
S86	30	("5440542", "5859840", "6266321", "6522638", "6707859", "6813323", "6816507", "6985471", "6987778", "7088697", "7088700", "7120131", "7177345", "7324568", "00005829", "03015310").pn.	US-PGPUB; USPAT; USOCR; EPO; JPO; DERWENT; IBM_TDB	OR	ON	2008/07/06 13:41
S87	0	S86 and ((control adj frame) with (channel near7 (control near5 channel)))	US-PGPUB; USPAT; USOCR; EPO; JPO; DERWENT; IBM_TDB	OR	ON	2008/07/06 13:42
S88	0	S86 and ((control adj frame) with (dedicated near7 (control near5 channel)))	US-PGPUB; USPAT; USOCR; EPO; JPO; DERWENT; IBM_TDB	OR	ON	2008/07/06 13:43

S89	0	S86 and ((control adj frame) same (dedicated near7 (control near5 channel)))	US-PGPUB; USPAT; USOCR; EPO; JPO; DERWENT; IBM_TDB	OR	ON	2008/07/06 13:43
S90	0	S86 and ((control adj frame) same (dedicated with (control near5 channel)))	US-PGPUB; USPAT; USOCR; EPO; JPO; DERWENT; IBM_TDB	OR	ON	2008/07/06 13:44
S91	1	S86 and ((control near5 frame) same (dedicated with (control near5 channel)))	US-PGPUB; USPAT; USOCR; EPO; JPO; DERWENT; IBM_TDB	OR	ON	2008/07/06 13:44
S92	8	(control near3 information) with (different near7 (slot near3 format))	US-PGPUB; USPAT; USOCR; EPO; JPO; DERWENT; IBM_TDB	OR	ON	2008/07/06 13:51
S93	0	((slot near5 (multiple or multiple)) and (control adj frame) and (dedicated near5 (control near3 channel))).clm.	US-PGPUB; USPAT; USOCR; EPO; JPO; DERWENT; IBM_TDB	OR	ON	2008/07/06 15:27
S94	14	((slot near5 (multiple or multiple)) and (control adj frame) and (dedicated near5 (control near3 channel)))	US-PGPUB; USPAT; USOCR; EPO; JPO; DERWENT; IBM_TDB	OR	ON	2008/07/06 15:28
S95	14	((slot near4 (multiple or multiple)) and (control adj frame) and (dedicated near4 (control near3 channel)))	US-PGPUB; USPAT; USOCR; EPO; JPO; DERWENT; IBM_TDB	OR	ON	2008/07/06 15:28
S96	6	("2002014136", "6747963").pn.	US-PGPUB; USPAT; USOCR; EPO; JPO; DERWENT; IBM_TDB	OR	ON	2008/07/06 16:10
S97	4	("20020141436", "6747963").pn.	US-PGPUB; USPAT; USOCR; EPO; JPO; DERWENT; IBM_TDB	OR	ON	2008/07/06 16:12
S98	2	"5987518".pn.	US-PGPUB; USPAT; USOCR; EPO; JPO; DERWENT; IBM_TDB	OR	ON	2008/07/06 16:34

S99	0	S98 and (transport near5 format)	US-PGPUB; USPAT; USOCR; EPO; JPO; DERWENT; IBM_TDB	OR	ON	2008/07/06 16:36
S100	0	S98 and (control adj frame)	US-PGPUB; USPAT; USOCR; EPO; JPO; DERWENT; IBM_TDB	OR	ON	2008/07/06 16:36
S101	2	"6868075".pn.	US-PGPUB; USPAT; USOCR; EPO; JPO; DERWENT; IBM_TDB	OR	ON	2008/08/27 12:05
S102	0	S101 and extract\$3	US-PGPUB; USPAT; USOCR; EPO; JPO; DERWENT; IBM_TDB	OR	ON	2008/08/27 12:05
S103	1	S101 and decod\$3	US-PGPUB; USPAT; USOCR; EPO; JPO; DERWENT; IBM_TDB	OR	ON	2008/08/27 12:06
S104	2	"20040100918"	US-PGPUB; USPAT; USOCR; EPO; JPO; DERWENT; IBM_TDB	OR	ON	2008/08/27 13:02
S105	1	S104 and extract\$3	US-PGPUB; USPAT; USOCR; EPO; JPO; DERWENT; IBM_TDB	OR	ON	2008/08/27 13:02
S106	0	((differnt near7 (number near3 bit?) and (control near5 (data or information or message or command)) and (slot near6 (multiple or plural or two or three)) and (control near3 frame))	US-PGPUB; USPAT; USOCR; EPO; JPO; DERWENT; IBM_TDB	OR	ON	2008/08/27 13:45
S107	139	((different near7 (number near3 bit?) and (control near5 (data or information or message or command)) and (slot near6 (multiple or plural or two or three)) and (control near3 frame))	US-PGPUB; USPAT; USOCR; EPO; JPO; DERWENT; IBM_TDB	OR	ON	2008/08/27 13:46

S108	126	((different near4 (number near3 bit?)) and (control near5 (data or information or message or command)) and (slot near6 (multiple or plural or two or three)) and (control near3 frame))	US-PGPUB; USPAT; USOCR; EPO; JPO; DERWENT; IBM_TDB	OR	ON	2008/08/27 13:46
S109	2	((different near4 (number near3 bit?)) and (control near5 (data or information or message or command)) and (slot near6 (multiple or plural or two or three)) and (control near3 frame) and (different near5 (slot near3 format)))	US-PGPUB; USPAT; USOCR; EPO; JPO; DERWENT; IBM_TDB	OR	ON	2008/08/27 13:46

9/ 3/ 2008 5:31:22 PM

C:\Documents and Settings\mzewdu\My Documents\EAST\Workspaces\workstation 1.wsp



APPLICATION NO. /CONTROL NO. 11199586	FILING DATE 8/8/2005	FIRST NAMED INVENTOR / PATENT IN REEXAMINATION LI ET AL.	ATTORNEY DOCKET NO. 68144/P014C1/1050 3148
--	-------------------------	---	--

EXAMINER Meless N. Zewdu

ART UNIT 2617	PAPER 20080903
------------------	-------------------

DATE MAILED:

Please find below and/or attached an Office communication concerning this application or proceeding.

Commissioner of Patents

This application contains sequence disclosures that are encompassed by the definitions for nucleotide and/or amino acid sequences set forth in 37 C.F.R. § 1.821(a)(1) and (a)(2). However, this application fails to comply with the requirements of 37 C.F.R. §§ 1.821-1.825 for the reason(s) set forth on the attached Notice To Comply With Requirements For Patent Applications Containing Nucleotide Sequence And/Or Amino Acid Sequence Disclosures. Applicant must comply with the requirements of the sequence rules (37 CFR 1.821 - 1.825) before the application can be examined under 35 U.S.C. §§ 131 and 132.

APPLICANT IS GIVEN ONE MONTH FROM THE DATE OF THIS LETTER WITHIN WHICH TO COMPLY WITH THE SEQUENCE RULES, 37 C.F.R. §§ 1.821-1.825. Failure to comply with these requirements will result in ABANDONMENT of the application under 37 C.F.R. § 1.821(g). Extensions of time may be obtained by filing a petition accompanied by the extension fee under the provisions of 37 C.F.R. § 1.136. In no case may an applicant extend the period for response beyond the six month statutory period. Direct the response to the undersigned. Applicant is requested to return a copy of the attached Notice to Comply with the response.

The addresses below are effective 5 June 2004. Please direct all replies to the United States Patent and Trademark Office via one (1) of the following:

1. Electronically submitted through EFS-Web (<<http://www.uspto.gov/efc/efs/downloads/documents.htm>>, EFS Submission User Manual - ePAVE)
2. Mailed to:
Mail Stop Sequence
Commissioner for Patents
P.O. Box 22313 1450
Alexandria, VA 22313 1450
3. Hand Carry, Federal Express, United Parcel Service or other delivery service to:
U.S. Patent and Trademark Office
Mail Stop Sequence
Customer Window
Randolph Building
401 Dulaney Street
Alexandria, VA 22314

Any inquiry concerning this communication should be directed to _____ at telephone number (571) 272-7873. If attempts to reach the examiner by telephone are unsuccessful, the examiner's supervisor, Bost Dwayne D, can be reached on _____



UNITED STATES PATENT AND TRADEMARK OFFICE

UNITED STATES DEPARTMENT OF COMMERCE
United States Patent and Trademark Office
Address: COMMISSIONER FOR PATENTS
P.O. Box 1450
Alexandria, Virginia 22313-1450
www.uspto.gov

APPLICATION NO.	FILING DATE	FIRST NAMED INVENTOR	ATTORNEY DOCKET NO.	CONFIRMATION NO.
11/199,586	08/08/2005	Xiaodong Li	68144/P014C1/10503148	1128

29053 7590 09/08/2008
FULBRIGHT & JAWORSKI L.L.P
2200 ROSS AVENUE
SUITE 2800
DALLAS, TX 75201-2784

EXAMINER

ZEWDU, MELESS NMN

ART UNIT	PAPER NUMBER
2617	

MAIL DATE	DELIVERY MODE
09/08/2008	PAPER

Please find below and/or attached an Office communication concerning this application or proceeding.

The time period for reply, if any, is set in the attached communication.

**Supplemental
Notice of Allowability**

Application No. 11/199,586	Applicant(s) LI ET AL.	
Examiner Meless N. Zewdu	Art Unit 2617	

-- The MAILING DATE of this communication appears on the cover sheet with the correspondence address--

All claims being allowable, PROSECUTION ON THE MERITS IS (OR REMAINS) CLOSED in this application. If not included herewith (or previously mailed), a Notice of Allowance (PTOL-85) or other appropriate communication will be mailed in due course. **THIS NOTICE OF ALLOWABILITY IS NOT A GRANT OF PATENT RIGHTS.** This application is subject to withdrawal from issue at the initiative of the Office or upon petition by the applicant. See 37 CFR 1.313 and MPEP 1308.

1. This communication is responsive to 8/4/08.
2. The allowed claim(s) is/are 1-4, 8, 12-20, 23, 26-27, 30-33, 37, 43-48, 52, 55-56, 58 and 60.
3. Acknowledgment is made of a claim for foreign priority under 35 U.S.C. § 119(a)-(d) or (f).
 - a) All b) Some* c) None of the:
 1. Certified copies of the priority documents have been received.
 2. Certified copies of the priority documents have been received in Application No. _____.
 3. Copies of the certified copies of the priority documents have been received in this national stage application from the International Bureau (PCT Rule 17.2(a)).

* Certified copies not received: _____.

Applicant has THREE MONTHS FROM THE "MAILING DATE" of this communication to file a reply complying with the requirements noted below. Failure to timely comply will result in ABANDONMENT of this application. **THIS THREE-MONTH PERIOD IS NOT EXTENDABLE.**

4. A SUBSTITUTE OATH OR DECLARATION must be submitted. Note the attached EXAMINER'S AMENDMENT or NOTICE OF INFORMAL PATENT APPLICATION (PTO-152) which gives reason(s) why the oath or declaration is deficient.
 5. CORRECTED DRAWINGS (as "replacement sheets") must be submitted.
 - (a) including changes required by the Notice of Draftsperson's Patent Drawing Review (PTO-948) attached
 - 1) hereto or 2) to Paper No./Mail Date _____.
 - (b) including changes required by the attached Examiner's Amendment / Comment or in the Office action of Paper No./Mail Date _____.
- Identifying indicia such as the application number (see 37 CFR 1.84(c)) should be written on the drawings in the front (not the back) of each sheet. Replacement sheet(s) should be labeled as such in the header according to 37 CFR 1.121(d).**
6. DEPOSIT OF and/or INFORMATION about the deposit of BIOLOGICAL MATERIAL must be submitted. Note the attached Examiner's comment regarding REQUIREMENT FOR THE DEPOSIT OF BIOLOGICAL MATERIAL.

Attachment(s)

- | | |
|---|---|
| <ol style="list-style-type: none"> 1. <input type="checkbox"/> Notice of References Cited (PTO-892) 2. <input type="checkbox"/> Notice of Draftsperson's Patent Drawing Review (PTO-948) 3. <input checked="" type="checkbox"/> Information Disclosure Statements (PTO/SB/08),
Paper No./Mail Date <u>8/26/08</u> 4. <input type="checkbox"/> Examiner's Comment Regarding Requirement for Deposit of Biological Material | <ol style="list-style-type: none"> 5. <input type="checkbox"/> Notice of Informal Patent Application 6. <input type="checkbox"/> Interview Summary (PTO-413),
Paper No./Mail Date _____. 7. <input type="checkbox"/> Examiner's Amendment/Comment 8. <input type="checkbox"/> Examiner's Statement of Reasons for Allowance 9. <input type="checkbox"/> Other _____. |
|---|---|



U.S. Patent and Trademark Office

Address : COMMISSIONER FOR PATENTS
P.O. Box 1450
Alexandria, Virginia 22313-1450

APPLICATION NO./ CONTROL NO.	FILING DATE	FIRST NAMED INVENTOR / PATENT IN REEXAMINATION	ATTORNEY DOCKET NO.
11199586	8/8/2005	LI ET AL.	68144/P014C1/10503148

FULBRIGHT & JAWORSKI L.L.P
2200 ROSS AVENUE
SUITE 2800
DALLAS, TX 75201-2784

EXAMINER

Meless N. Zewdu

ART UNIT	PAPER
-----------------	--------------

2617 20080903

DATE MAILED:

Please find below and/or attached an Office communication concerning this application or proceeding.

Commissioner for Patents

The references listed in the substitute IDS form 1449/PTO and submitted on 8/26/08 have been considered by examiner of the record.

/Meless N Zewdu/
Primary Examiner, Art Unit 2617

Under the Paperwork Reduction Act of 1995, no persons are required to respond to a collection of information unless it contains a valid OMB control number.

Substitute for form 1449/PTO			Complete if Known	
			Application Number	11/199,586-Conf. #1128
INFORMATION DISCLOSURE STATEMENT BY APPLICANT			Filing Date	August 8, 2005
			First Named Inventor	Xiaodong Li
			Art Unit	2617
			Examiner Name	M. N. Zewdu
			Attorney Docket Number	68144/P014C1/10503148
Sheet	1	of	1	

U.S. PATENT DOCUMENTS						
Examiner Initials*	Cite No. ¹	Document Number		Publication Date MM-DD-YYYY	Name of Patentee or Applicant of Cited Document	Pages, Columns, Lines, Where Relevant Passages or Relevant Figures Appear
		Number-Kind Code ² (if known)				
/MZ/	AA*	US-6,052,594		04-18-2000	Chuang et al.	/
	AB*	US-6,526,281		02-25-2003	Gorsuch et al.	
	AC*	US-6,985,432		01-10-2006	Hadad et al.	
	AD*	US-7,373,151		05-13-2008	Ahmed	
	AE*	US-7,047,011		05-16-2006	Wikman et al.	
	AF*	US-6,411,186		06-25-2002	Lilleberg et al.	
	AG*	US-4,670,889		06-02-1987	Hewitt et al.	
	AH*	US-5,839,074		11-17-1998	Plehn et al.	
	AI*	US-6,415,153		07-02-2002	Liew	
	AJ*	US-6,920,122		07-19-2005	Hanaoka et al.	
	AK	US-5,437,054		07-25-1995	Rappaport et al.	
/MZ/	AL	US-6,023,622		02-08-2000	Plaschke et al.	

FOREIGN PATENT DOCUMENTS							
Examiner Initials*	Cite No. ¹	Foreign Patent Document		Publication Date MM-DD-YYYY	Name of Patentee or Applicant of Cited Document	Pages, Columns, Lines, Where Relevant Passages Or Relevant Figures Appear	T ⁶
		Country Code ³ -Number ⁴ -Kind Code ⁵ (if known)					

Examiner Signature	/Meless Zewdu/ (09/03/2008)	Date Considered	
--------------------	-----------------------------	-----------------	--

*EXAMINER: Initial if reference considered, whether or not citation is in conformance with MPEP 609. Draw line through citation if not in conformance and not considered. Include copy of this form with next communication to applicant. * CITE NO.: Those application(s) which are marked with an asterisk (*) next to the Cite No. are not supplied (under 37 CFR 1.98(a)(2)(iii)) because that application was filed after June 30, 2003 or is available in the IFW. ¹ Applicant's unique citation designation number (optional). ² See Kinds Codes of USPTO Patent Documents at www.uspto.gov or MPEP 901.04. ³ Enter Office that issued the document, by the two-letter code (WIPO Standard ST.3). ⁴ For Japanese patent documents, the indication of the year of the reign of the Emperor must precede the serial number of the patent document. ⁵ Kind of document by the appropriate symbols as indicated on the document under WIPO Standard ST.16 if possible. ⁶ Applicant is to place a check mark here if English language Translation is attached.

IDS (Citation) by Applicant (12 References)	
I hereby certify that this paper (along with any paper referred to as being attached or enclosed) is being transmitted via the Office electronic filing system in accordance with § 1.6(a)(4).	
Dated: August 26, 2008	Signature: <u>Carol Martin</u> (Carol Martin)



UNITED STATES PATENT AND TRADEMARK OFFICE

UNITED STATES DEPARTMENT OF COMMERCE
United States Patent and Trademark Office
Address: COMMISSIONER FOR PATENTS
P.O. Box 1450
Alexandria, Virginia 22313-1450
www.uspto.gov

APPLICATION NO.	FILING DATE	FIRST NAMED INVENTOR	ATTORNEY DOCKET NO.	CONFIRMATION NO.
11/199,586	08/08/2005	Xiaodong Li	68144/P014C1/10503148	1128

29053 7590 09/26/2008
FULBRIGHT & JAWORSKI L.L.P
2200 ROSS AVENUE
SUITE 2800
DALLAS, TX 75201-2784

EXAMINER

ZEWDU, MELESS NMN

ART UNIT PAPER NUMBER

2617

MAIL DATE DELIVERY MODE

09/26/2008

PAPER

Please find below and/or attached an Office communication concerning this application or proceeding.

The time period for reply, if any, is set in the attached communication.

Examiner-Initiated Interview Summary	Application No.	Applicant(s)	
	11/199,586	LI ET AL.	
	Examiner	Art Unit	
	Meless N. Zewdu	2617	

All Participants:

- (1) Meless N. Zewdu.
- (2) Robert L. Green (Reg. NO. 52.966).

Status of Application: _____

- (3) _____.
- (4) _____.

Date of Interview: 23 September 2008

Time: _____

Type of Interview:

- Telephonic
- Video Conference
- Personal (Copy given to: Applicant Applicant's representative)

Exhibit Shown or Demonstrated: Yes No
 If Yes, provide a brief description:

Part I.

Rejection(s) discussed:
N/A

Claims discussed:
N/A

Prior art documents discussed:
N/A

Part II.

SUBSTANCE OF INTERVIEW DESCRIBING THE GENERAL NATURE OF WHAT WAS DISCUSSED:

In a communication mailed out to applicant on 9/8/08, a PTO 90C Sequence Compliance Form, requiring applicant to comply with requirements for patent applications containing Nucleotide Sequences and/or Amino Acid Sequence Disclosures, was inadvertently included. Applicant has previously brought this matter to examiner's attention. After going through the files, examiner has determined it was an inadvertent error. Examiner, on 9/23/08, informed applicant that the requirement mentioned above will be removed from the record via the venue of this examiner's amendment. Consequently, the PTO 90C Sequence compliance form mailed to applicant on 9/8/08 has been hereby removed from the record and applicant has no time period to respond/comply to the said requirement.

Part III.

- It is not necessary for applicant to provide a separate record of the substance of the interview, since the interview directly resulted in the allowance of the application. The examiner will provide a written summary of the substance of the interview in the Notice of Allowability.
- It is not necessary for applicant to provide a separate record of the substance of the interview, since the interview did not result in resolution of all issues. A brief summary by the examiner appears in Part II above.

/Meless N Zewdu/
 Primary Examiner, Art Unit 2617

(Applicant/Applicant's Representative Signature – if appropriate)

Certificate of Electronic Filing Under 37 CFR 1.8

I hereby certify that this correspondence is being transmitted via the Office electronic filing system in accordance with 37 CFR 1.6(a)(4):

Mail Stop Issue Fee
Commissioner for Patents
P.O. Box 1450
Alexandria, VA 22313-1450

on October 13, 2008
Date



Signature

Scott Matthews

Typed or printed name of person signing Certificate

N/A

Registration Number, if applicable

(214) 855-7415

Telephone Number

Note: Each paper must have its own certificate of mailing.

Certificate of E-filing (1 page)
Part B-Issue Fee Transmittal (1 page)

Electronic Acknowledgement Receipt

EFS ID:	4103954
Application Number:	11199586
International Application Number:	
Confirmation Number:	1128
Title of Invention:	OFDMA WITH ADAPTIVE SUBCARRIER-CLUSTER CONFIGURATION AND SELECTIVE LOADING
First Named Inventor/Applicant Name:	Xiaodong Li
Customer Number:	29053
Filer:	David H. Tannenbaum/Scott Matthews
Filer Authorized By:	David H. Tannenbaum
Attorney Docket Number:	68144/P014C1/10503148
Receipt Date:	13-OCT-2008
Filing Date:	08-AUG-2005
Time Stamp:	16:45:23
Application Type:	Utility under 35 USC 111(a)

Payment information:

Submitted with Payment	yes
Payment Type	Deposit Account
Payment was successfully received in RAM	\$ 1055
RAM confirmation Number	8996
Deposit Account	062380
Authorized User	

The Director of the USPTO is hereby authorized to charge indicated fees and credit any overpayment as follows:

Charge any Additional Fees required under 37 C.F.R. Section 1.16 (National application filing, search, and examination fees)

Charge any Additional Fees required under 37 C.F.R. Section 1.17 (Patent application and reexamination processing fees)

Charge any Additional Fees required under 37 C.F.R. Section 1.19 (Document supply fees)

Charge any Additional Fees required under 37 C.F.R. Section 1.20 (Post Issuance fees)

Charge any Additional Fees required under 37 C.F.R. Section 1.21 (Miscellaneous fees and charges)

File Listing:

Document Number	Document Description	File Name	File Size(Bytes)/ Message Digest	Multi Part /.zip	Pages (if appl.)
1		11199586IssueFee.pdf	122373 aedf16624497eae21f9a48697f6d0511f58f e0f	yes	2
Multipart Description/PDF files in .zip description					
	Document Description		Start		End
	Miscellaneous Incoming Letter		1		1
	Issue Fee Payment (PTO-85B)		2		2

Warnings:

Information:

2	Fee Worksheet (PTO-06)	fee-info.pdf	32291 e48adbbb3541bf66f2370becab1f3677936c 8ced	no	2
---	------------------------	--------------	---	----	---

Warnings:

Information:

Total Files Size (in bytes): 154664

This Acknowledgement Receipt evidences receipt on the noted date by the USPTO of the indicated documents, characterized by the applicant, and including page counts, where applicable. It serves as evidence of receipt similar to a Post Card, as described in MPEP 503.

New Applications Under 35 U.S.C. 111

If a new application is being filed and the application includes the necessary components for a filing date (see 37 CFR 1.53(b)-(d) and MPEP 506), a Filing Receipt (37 CFR 1.54) will be issued in due course and the date shown on this Acknowledgement Receipt will establish the filing date of the application.

National Stage of an International Application under 35 U.S.C. 371

If a timely submission to enter the national stage of an international application is compliant with the conditions of 35 U.S.C. 371 and other applicable requirements a Form PCT/DO/EO/903 indicating acceptance of the application as a national stage submission under 35 U.S.C. 371 will be issued in addition to the Filing Receipt, in due course.

New International Application Filed with the USPTO as a Receiving Office

If a new international application is being filed and the international application includes the necessary components for an international filing date (see PCT Article 11 and MPEP 1810), a Notification of the International Application Number and of the International Filing Date (Form PCT/RO/105) will be issued in due course, subject to prescriptions concerning national security, and the date shown on this Acknowledgement Receipt will establish the international filing date of the application.

Electronic Patent Application Fee Transmittal

Application Number:	11199586
Filing Date:	08-Aug-2005
Title of Invention:	OFDMA WITH ADAPTIVE SUBCARRIER-CLUSTER CONFIGURATION AND SELECTIVE LOADING
First Named Inventor/Applicant Name:	Xiaodong Li
Filer:	David H. Tannenbaum/Scott Matthews
Attorney Docket Number:	68144/P014C1/10503148

Filed as Small Entity

Utility under 35 USC 111(a) Filing Fees

Description	Fee Code	Quantity	Amount	Sub-Total in USD(\$)
Basic Filing:				
Pages:				
Claims:				
Miscellaneous-Filing:				
Petition:				
Patent-Appeals-and-Interference:				
Post-Allowance-and-Post-Issuance:				
Utility Appl issue fee	2501	1	755	755
Publ. Fee- early, voluntary, or normal	1504	1	300	300

Description	Fee Code	Quantity	Amount	Sub-Total in USD(\$)
Extension-of-Time:				
Miscellaneous:				
Total in USD (\$)				1055

PART B - FEE(S) TRANSMITTAL

Complete and send this form, together with applicable fee(s), to: **Mail** Mail Stop **ISSUE FEE**
Commissioner for Patents
P.O. Box 1450
Alexandria, Virginia 22313-1450
 or **Fax** (571)-273-2885

INSTRUCTIONS: This form should be used for transmitting the **ISSUE FEE** and **PUBLICATION FEE** (if required). Blocks 1 through 5 should be completed where appropriate. All further correspondence including the Patent, advance orders and notification of maintenance fees will be mailed to the current correspondence address as indicated unless corrected below or directed otherwise in Block 1, by (a) specifying a new correspondence address; and/or (b) indicating a separate "FEE ADDRESS" for maintenance fee notifications.

CURRENT CORRESPONDENCE ADDRESS (Note: Use Block 1 for any change of address)

29053 7590 08/22/2008
FULBRIGHT & JAWORSKI L.L.P.
 2200 ROSS AVENUE
 SUITE 2800
 DALLAS, TX 75201-2784

Note: A certificate of mailing can only be used for domestic mailings of the Fee(s) Transmittal. This certificate cannot be used for any other accompanying papers. Each additional paper, such as an assignment or formal drawing, must have its own certificate of mailing or transmission.

Certificate of Mailing or Transmission

I hereby certify that this Fee(s) Transmittal is being deposited with the United States Postal Service with sufficient postage for first class mail in an envelope addressed to the Mail Stop **ISSUE FEE** address above, or being facsimile transmitted to the USPTO (571) 273-2885, on the date indicated below.

(Depositor's name)
(Signature)
(Date)

APPLICATION NO.	FILING DATE	FIRST NAMED INVENTOR	ATTORNEY DOCKET NO.	CONFIRMATION NO.
11/199,586	08/08/2005	Xiaodong Li	68144/P014C1/10503148	1128

TITLE OF INVENTION: OFDMA WITH ADAPTIVE SUBCARRIER-CLUSTER CONFIGURATION AND SELECTIVE LOADING

APPLN. TYPE	SMALL ENTITY	ISSUE FEE DUE	PUBLICATION FEE DUE	PREV. PAID ISSUE FEE	TOTAL FEE(S) DUE	DATE DUE
nonprovisional	YES	\$720	\$300	\$0	\$1020	11/24/2008

EXAMINER	ART UNIT	CLASS-SUBCLASS
ZEWDU, MELESS NMN	2617	455-447000

1. Change of correspondence address or indication of "Fee Address" (37 CFR 1.363). <input type="checkbox"/> Change of correspondence address (or Change of Correspondence Address form PTO/SB/122) attached. <input type="checkbox"/> "Fee Address" indication (or "Fee Address" Indication form PTO/SB/47; Rev 03-02 or more recent) attached. Use of a Customer Number is required.	2. For printing on the patent front page, list (1) the names of up to 3 registered patent attorneys or agents OR, alternatively, (2) the name of a single firm (having as a member a registered attorney or agent) and the names of up to 2 registered patent attorneys or agents. If no name is listed, no name will be printed.	1 _____ 2 <u>Fulbright & Jaworski L.L.P.</u> 3 _____
---	---	--

3. ASSIGNEE NAME AND RESIDENCE DATA TO BE PRINTED ON THE PATENT (print or type)

PLEASE NOTE: Unless an assignee is identified below, no assignee data will appear on the patent. If an assignee is identified below, the document has been filed for recordation as set forth in 37 CFR 3.11. Completion of this form is NOT a substitute for filing an assignment.

(A) NAME OF ASSIGNEE: Adaptix, Inc. (B) RESIDENCE: (CITY and STATE OR COUNTRY) Bellevue, WA

Please check the appropriate assignee category or categories (will not be printed on the patent): Individual Corporation or other private group entity Government

4a. The following fee(s) are submitted: <input checked="" type="checkbox"/> Issue Fee <input checked="" type="checkbox"/> Publication Fee (No small entity discount permitted) <input type="checkbox"/> Advance Order - # of Copies _____	4b. Payment of Fee(s): (Please first reapply any previously paid issue fee shown above) <input type="checkbox"/> A check is enclosed. <input type="checkbox"/> Payment by credit card. Form PTO-2038 is attached. <input checked="" type="checkbox"/> The Director is hereby authorized to charge the required fee(s), any deficiency, or credit any overpayment, to Deposit Account Number <u>06-2380</u> (enclose an extra copy of this form).
--	---

5. Change in Entity Status (from status indicated above)

a. Applicant claims SMALL ENTITY status. See 37 CFR 1.27. b. Applicant is no longer claiming SMALL ENTITY status. See 37 CFR 1.27(g)(2).

NOTE: The Issue Fee and Publication Fee (if required) will not be accepted from anyone other than the applicant; a registered attorney or agent; or the assignee or other party in interest as shown by the records of the United States Patent and Trademark Office.

Authorized Signature: Robert L. Greeson Date: October 13, 2008
 Typed or printed name: Robert L. Greeson Registration No. 52,966

This collection of information is required by 37 CFR 1.311. The information is required to obtain or retain a benefit by the public which is to file (and by the USPTO to process) an application. Confidentiality is governed by 35 U.S.C. 122 and 37 CFR 1.14. This collection is estimated to take 12 minutes to complete, including gathering, preparing, and submitting the completed application form to the USPTO. Time will vary depending upon the individual case. Any comments on the amount of time you require to complete this form and/or suggestions for reducing this burden, should be sent to the Chief Information Officer, U.S. Patent and Trademark Office, U.S. Department of Commerce, P.O. Box 1450, Alexandria, Virginia 22313-1450. DO NOT SEND FEES OR COMPLETED FORMS TO THIS ADDRESS. SEND TO: Commissioner for Patents, P.O. Box 1450, Alexandria, Virginia 22313-1450.

Under the Paperwork Reduction Act of 1995, no persons are required to respond to a collection of information unless it displays a valid OMB control number.



PTO/SB/08A (10-01)

Approved for use through 10/31/2002. OMB 0651-0031

U. S. Patent and Trademark Office: U. S. DEPARTMENT OF COMMERCE

Under the Paperwork Reduction Act of 1995, no persons are required to respond to a collection of information unless it contains a valid OMB control number.

Substitute for form 1449A/PTO		Complete if Known	
INFORMATION DISCLOSURE STATEMENT BY APPLICANT (use as many sheets as necessary)		Application Number	11/199,586
		Filing Date	August 8, 2005
		First Named Inventor	Xiaodong Li
		Art Unit	2661
		Examiner Name	Not Yet Assigned
		Attorney Docket Number	68144/P014C1/10503148
Sheet	2	of	4

MZ	AT1	US-6,377,636 B1**	04-23-2002	Paulraj et al.	
MZ	AU1	US-6,330,460 B1**	12-11-2001	Wong et al.	
MZ	AV1	US-6,327,472 B1**	12-04-2001	Westroos et al.	
MZ	AW1	US-5,507,034**	04-09-1996	Bodin et al.	
MZ	AX1	US-6,141,565**	10-31-2000	Feuerstein et al.	
MZ	AY1	US-6,298,092 B1**	10-02-2001	Heath, Jr.	
MZ	AZ1	US-5,774,808**	06-30-1998	Sarkioja et al.	
MZ	AA2	US-6,726,297**	04/2004	Uesugi, Mitsuru	
MZ	AB2	US-2005/0025099**	02/2005	Heath et al.	
MZ	AC2	US-2002/0114269 A1**	08/2002	Onggosanusi et al.	
MZ	AD2	US-6,567,383 B1**	05/2003	Bohnke	
MZ	AE2	US-5,726,978**	03/10/1998	Frodigh et al.	
MZ	AF2	US-5,280,630**	01/18/1994	Wang	

AP 12/15/05

FOREIGN PATENT DOCUMENTS						
Examiner Initials*	Cite No.	Foreign Patent Document		Publication Date MM-DD-YYYY	Name of Patentee or Applicant of Cited Document	Pages, Columns, Lines, Where Relevant, Passages or Relevant Figures Appear
		Country Code ¹	Number ² -Kind Code ³ (if known)			
MZ	BA	-GB	2 209 858 A**	08-06-1997	Motorola Limited	
MZ	BB	-WO	98/30047 A1**	07-09-1998	Array-Comm, Inc.	
MZ	BC	-WO	98/16077 A2**	04-16-1998	Teratech Corporation	
MZ	BD	-EP	0 926 912 A2**	08-30-1999	CSELT Centro Studie Lab	
MZ	BE	-198	00 953 C1**	07-29-1999	Siemens AG	
MZ	BF	-EP	0 869 847 A2**	10-07-1998	Lucent Technologies, Inc.	
MZ	BG	-FR	2 777 407 A1**	10-15-1999	Wavecom SA	
MZ	BH	-EP	0 929 202 A1**	07-14-1999	Lucent Technologies, Inc.	
MZ	BI	-WO	02 48305 A2**	08-20-2002	Broadstorm Telecommunications	
MZ	BJ	-JP	05029922**	02-04-1994	Mitsuru et al.	
MZ	BK	-EP	0899858**	05-10-2000	Farrokh Rashid-Farrokhi	
MZ	BL	-DE	198 00 953**	07-29-1999	Siemens AG	
MZ	BM	-EP	0 999 658**	0510-2000	Lucent Technologies, Inc.	

*EXAMINER: Initial if reference considered, whether or not citation is in conformance with MPEP 609. Draw line through citation if not in conformance and not considered. Include copy of this form with next communication to applicant.

¹ Applicant's unique citation designation number (optional). ² See attached Kinds Codes of USPTO Patent Documents at www.uspto.gov or MPEP 901.04. ³ Enter Office that issued the document, by the two-letter code (WIPO Standard ST.3). ⁴ For Japanese patent documents, the indication of the year of the reign of the Emperor must precede the application number of the patent document. ⁵ Kind of document by the appropriate symbols as indicated on the document under WIPO Standard ST. 16 if possible. ⁶ Applicant is to place a check mark here if English language Translation is attached.

NON PATENT LITERATURE DOCUMENTS			
Examiner Initials	Cite No.	Include name of the author (in CAPITAL LETTERS), title of the article (when appropriate), title of the item (book, magazine, journal, serial, symposium, catalog, etc), date, page(s), volume-issue number(s), publisher, city and/or country where published.	T ²
MZ	CA	BENDER et al., CDMA/HDR: A Bandwidth-Efficient High-Speed Wireless Data Service for Nomadic Users, IEEE Communications Magazine, July 2000, pp. 70-87.**	
MZ	CB	FRULLONE et al., PRMA Performance in Cellular Environments with Self-Adaptive Channel Allocation Strategies, IEEE Transactions on Vehicular Technology, November 1998, pp. 657-665, Vol. 45, No. 4.**	
MZ	CC	XU, GUANGHAN and LI, SAN-QI, Throughput Multiplication of Wireless Lans for Multimedia Services: SDMA Protocol Design, 1994 IEEE, pp. 1326-1332.**	
Examiner Signature	/Meless Zewdu/		Date Considered 08/18/2006

25678792.1



APPLICATION NO.	ISSUE DATE	PATENT NO.	ATTORNEY DOCKET NO.	CONFIRMATION NO.
11/199.586	11/18/2008	7454212	68144/P014C1/10503148	1128

29053 7590 10/29/2008
FULBRIGHT & JAWORSKI L.L.P
2200 ROSS AVENUE
SUITE 2800
DALLAS, TX 75201-2784

ISSUE NOTIFICATION

The projected patent number and issue date are specified above.

Determination of Patent Term Adjustment under 35 U.S.C. 154 (b) (application filed on or after May 29, 2000)

The Patent Term Adjustment is 0 day(s). Any patent to issue from the above-identified application will include an indication of the adjustment on the front page.

If a Continued Prosecution Application (CPA) was filed in the above-identified application, the filing date that determines Patent Term Adjustment is the filing date of the most recent CPA.

Applicant will be able to obtain more detailed information by accessing the Patent Application Information Retrieval (PAIR) WEB site (<http://pair.uspto.gov>).

Any questions regarding the Patent Term Extension or Adjustment determination should be directed to the Office of Patent Legal Administration at (571)-272-7702. Questions relating to issue and publication fee payments should be directed to the Customer Service Center of the Office of Patent Publication at (571)-272-4200.

APPLICANT(s) (Please see PAIR WEB site <http://pair.uspto.gov> for additional applicants):

- Xiaodong Li, Bellevue, WA;
- Hui Lui, Sammamish, WA;
- Kemin Li, Bellevue, WA;
- Wenzhong Zhang, Bellevue, WA;

AO 120 (Rev. 08/10)

TO: Mail Stop 8 Director of the U.S. Patent and Trademark Office P.O. Box 1450 Alexandria, VA 22313-1450	REPORT ON THE FILING OR DETERMINATION OF AN ACTION REGARDING A PATENT OR TRADEMARK
---	--

In Compliance with 35 U.S.C. § 290 and/or 15 U.S.C. § 1116 you are hereby advised that a court action has been filed in the U.S. District Court Eastern District of Texas on the following

Trademarks or Patents. (the patent action involves 35 U.S.C. § 292.):

DOCKET NO. 6:12cv016	DATE FILED 1/13/2012	U.S. DISTRICT COURT Eastern District of Texas
PLAINTIFF Adaptix, Inc.		DEFENDANT Motorola Mobility, Inc. and Cellco Partnership d/b/a Verizon Wireless ("Verizon")
PATENT OR TRADEMARK NO.	DATE OF PATENT OR TRADEMARK	HOLDER OF PATENT OR TRADEMARK
1 7,454,212	11/18/2008	Adaptix, Inc.
2 6,947,748	9/20/2005	Adaptix, Inc.
3		
4		
5		

In the above—entitled case, the following patent(s)/ trademark(s) have been included:

DATE INCLUDED	INCLUDED BY <input type="checkbox"/> Amendment <input type="checkbox"/> Answer <input type="checkbox"/> Cross Bill <input type="checkbox"/> Other Pleading	
PATENT OR TRADEMARK NO.	DATE OF PATENT OR TRADEMARK	HOLDER OF PATENT OR TRADEMARK
1		
2		
3		
4		
5		

In the above—entitled case, the following decision has been rendered or judgement issued:

DECISION/JUDGEMENT

CLERK	(BY) DEPUTY CLERK	DATE
-------	-------------------	------

Copy 1—Upon initiation of action, mail this copy to Director Copy 3—Upon termination of action, mail this copy to Director
 Copy 2—Upon filing document adding patent(s), mail this copy to Director Copy 4—Case file copy

AO 120 (Rev. 08/10)

TO: Mail Stop 8 Director of the U.S. Patent and Trademark Office P.O. Box 1450 Alexandria, VA 22313-1450	REPORT ON THE FILING OR DETERMINATION OF AN ACTION REGARDING A PATENT OR TRADEMARK
---	---

In Compliance with 35 U.S.C. § 290 and/or 15 U.S.C. § 1116 you are hereby advised that a court action has been filed in the U.S. District Court Eastern District of Texas on the following
 Trademarks or Patents. (the patent action involves 35 U.S.C. § 292.);

DOCKET NO. 6:12cv019	DATE FILED 1/13/2012	U.S. DISTRICT COURT Eastern District of Texas
PLAINTIFF Adaptix, Inc.		DEFENDANT AT&T, Inc., AT&T Mobility LLC, Cellco Partnership d/b/a Verizon Wireless, HTC Corporation and HTC America, Inc.
PATENT OR TRADEMARK NO.	DATE OF PATENT OR TRADEMARK	HOLDER OF PATENT OR TRADEMARK
1 7,454,212	11/18/2008	Adaptix, Inc.
2 6,947,748	9/20/2005	Adaptix, Inc.
3		
4		
5		

In the above—entitled case, the following patent(s)/ trademark(s) have been included:

DATE INCLUDED	INCLUDED BY	
	<input type="checkbox"/> Amendment <input type="checkbox"/> Answer <input type="checkbox"/> Cross Bill <input type="checkbox"/> Other Pleading	
PATENT OR TRADEMARK NO.	DATE OF PATENT OR TRADEMARK	HOLDER OF PATENT OR TRADEMARK
1		
2		
3		
4		
5		

In the above—entitled case, the following decision has been rendered or judgement issued:

DECISION/JUDGEMENT

CLERK	(BY) DEPUTY CLERK	DATE
-------	-------------------	------

Copy 1—Upon initiation of action, mail this copy to Director Copy 3—Upon termination of action, mail this copy to Director
 Copy 2—Upon filing document adding patent(s), mail this copy to Director Copy 4—Case file copy

AO 120 (Rev. 08/10)

TO: Mail Stop 8 Director of the U.S. Patent and Trademark Office P.O. Box 1450 Alexandria, VA 22313-1450	REPORT ON THE FILING OR DETERMINATION OF AN ACTION REGARDING A PATENT OR TRADEMARK
---	---

In Compliance with 35 U.S.C. § 290 and/or 15 U.S.C. § 1116 you are hereby advised that a court action has been filed in the U.S. District Court Eastern District of Texas on the following

Trademarks or Patents. (the patent action involves 35 U.S.C. § 292.);

DOCKET NO. 6:12cv017	DATE FILED 1/13/2012	U.S. DISTRICT COURT Eastern District of Texas
PLAINTIFF Adaptix, Inc.		DEFENDANT AT&T, Inc., AT&T Mobility LLC, Cellco Partnership d/b/a Verizon Wireless, LG Electronics, Inc. and LG Electronics USA, Inc.
PATENT OR TRADEMARK NO.	DATE OF PATENT OR TRADEMARK	HOLDER OF PATENT OR TRADEMARK
1 7,454,212	11/18/2008	Adaptix, Inc.
2 6,947,748	9/20/2005	Adaptix, Inc.
3		
4		
5		

In the above—entitled case, the following patent(s)/ trademark(s) have been included:

DATE INCLUDED	INCLUDED BY	
	<input type="checkbox"/> Amendment <input type="checkbox"/> Answer <input type="checkbox"/> Cross Bill <input type="checkbox"/> Other Pleading	
PATENT OR TRADEMARK NO.	DATE OF PATENT OR TRADEMARK	HOLDER OF PATENT OR TRADEMARK
1		
2		
3		
4		
5		

In the above—entitled case, the following decision has been rendered or judgement issued:

DECISION/JUDGEMENT

CLERK	(BY) DEPUTY CLERK	DATE
-------	-------------------	------

Copy 1—Upon initiation of action, mail this copy to Director Copy 3—Upon termination of action, mail this copy to Director
 Copy 2—Upon filing document adding patent(s), mail this copy to Director Copy 4—Case file copy

Under the Paperwork Reduction Act of 1995, no persons are required to respond to a collection of information unless it displays a valid OMB control number.

POWER OF ATTORNEY TO PROSECUTE APPLICATIONS BEFORE THE USPTO

I hereby revoke all previous powers of attorney given in the application identified in the attached statement under 37 CFR 3.73(b).

I hereby appoint:

 Practitioners associated with the Customer Number:

22882

OR

 Practitioner(s) named below (if more than ten patent practitioners are to be named, then a customer number must be used):

Name	Registration Number	Name	Registration Number

as attorney(s) or agent(s) to represent the undersigned before the United States Patent and Trademark Office (USPTO) in connection with any and all patent applications assigned only to the undersigned according to the USPTO assignment records or assignment documents attached to this form in accordance with 37 CFR 3.73(b).

Please change the correspondence address for the application identified in the attached statement under 37 CFR 3.73(b) to:

 The address associated with Customer Number:

22882

OR

<input type="checkbox"/> Firm or Individual Name			
Address			
City	State	Zip	
Country			
Telephone	Email		

Assignee Name and Address:

ADAPTIX, Inc.
4100 Midway Road, Suite 2010
Carrollton, TX 75007 USA

A copy of this form, together with a statement under 37 CFR 3.73(b) (Form PTO/SB/96 or equivalent) is required to be filed in each application in which this form is used. The statement under 37 CFR 3.73(b) may be completed by one of the practitioners appointed in this form if the appointed practitioner is authorized to act on behalf of the assignee, and must identify the application in which this Power of Attorney is to be filed.

SIGNATURE of Assignee of Record

The individual whose signature and title is supplied below is authorized to act on behalf of the assignee

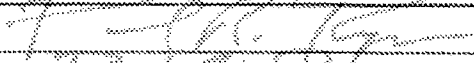
Signature		Date	Feb 16, 2012
Name	Paul R. Kohn	Telephone	714 480 360
Title	CEO		

This collection of information is required by 37 CFR 1.31, 1.32 and 1.33. The information is required to obtain or retain a benefit by the public which is to file (and by the USPTO to process) an application. Confidentiality is governed by 35 U.S.C. 122 and 37 CFR 1.11 and 1.14. This collection is estimated to take 3 minutes to complete, including gathering, preparing, and submitting the completed application form to the USPTO. Time will vary depending upon the individual case. Any comments on the amount of time you require to complete this form and/or suggestions for reducing this burden, should be sent to the Chief Information Officer, U.S. Patent and Trademark Office, U.S. Department of Commerce, P.O. Box 1450, Alexandria, VA 22313-1450. DO NOT SEND FEES OR COMPLETED FORMS TO THIS ADDRESS. SEND TO: Commissioner for Patents, P.O. Box 1450, Alexandria, VA 22313-1450.

If you need assistance in completing the form, call 1-800-PTO-8198 and select option 2.

Electronic Acknowledgement Receipt

EFS ID:	12131122
Application Number:	11199586
International Application Number:	
Confirmation Number:	1128
Title of Invention:	OFDMA WITH ADAPTIVE SUBCARRIER-CLUSTER CONFIGURATION AND SELECTIVE LOADING
First Named Inventor/Applicant Name:	Xiaodong Li
Customer Number:	29053
Filer:	Amedeo F. Ferraro
Filer Authorized By:	
Attorney Docket Number:	68144/P014C1/10503148
Receipt Date:	28-FEB-2012
Filing Date:	08-AUG-2005
Time Stamp:	14:13:03
Application Type:	Utility under 35 USC 111(a)

Payment information:

Submitted with Payment	no
------------------------	----

File Listing:

Document Number	Document Description	File Name	File Size(Bytes)/ Message Digest	Multi Part /.zip	Pages (if appl.)
1	Power of Attorney	PowerofAttorney.pdf	406522 <small>537ab39bf629d7ed1bbbe33c923915c46927dd7cd</small>	no	1

Warnings:

Information:

2	Assignee showing of ownership per 37 CFR 3.73(b).	373b.pdf	594021 a5de11c1c94b68a6a518dbec4f760961a456a6d	no	2
---	---	----------	---	----	---

Warnings:

Information:

Total Files Size (in bytes):	1000543
-------------------------------------	---------

This Acknowledgement Receipt evidences receipt on the noted date by the USPTO of the indicated documents, characterized by the applicant, and including page counts, where applicable. It serves as evidence of receipt similar to a Post Card, as described in MPEP 503.

New Applications Under 35 U.S.C. 111

If a new application is being filed and the application includes the necessary components for a filing date (see 37 CFR 1.53(b)-(d) and MPEP 506), a Filing Receipt (37 CFR 1.54) will be issued in due course and the date shown on this Acknowledgement Receipt will establish the filing date of the application.

National Stage of an International Application under 35 U.S.C. 371

If a timely submission to enter the national stage of an international application is compliant with the conditions of 35 U.S.C. 371 and other applicable requirements a Form PCT/DO/EO/903 indicating acceptance of the application as a national stage submission under 35 U.S.C. 371 will be issued in addition to the Filing Receipt, in due course.

New International Application Filed with the USPTO as a Receiving Office

If a new international application is being filed and the international application includes the necessary components for an international filing date (see PCT Article 11 and MPEP 1810), a Notification of the International Application Number and of the International Filing Date (Form PCT/RO/105) will be issued in due course, subject to prescriptions concerning national security, and the date shown on this Acknowledgement Receipt will establish the international filing date of the application.



Under the Paperwork Reduction Act of 1995, no persons are required to respond to a collection of information unless it displays a valid OMB control number.

STATEMENT UNDER 37 CFR 3.73(b)

Applicant/Patent Owner: Xiaodong Li, et al.

Application No./Patent No./Control No.: 11/199,588 Filed/Issue Date: August 8, 2005

Entitled: OFDMA WITH ADAPTIVE SUBCARRIER-CLUSTER CONFIGURATION AND SELECTIVE LOADING

Adaptix, Inc., a Corporation
(Name of Assignee) (Type of Assignee, e.g., corporation, partnership, university, government agency, etc.)

states that it is:

- 1. the assignee of the entire right, title, and interest; or
- 2. an assignee of less than the entire right, title and interest.
(The extent (by percentage) of its ownership interest is _____ %)

In the patent application/patent identified above by virtue of either:

A. An assignment from the inventor(s) of the patent application/patent identified above. The assignment was recorded in the United States Patent and Trademark Office at Reel _____, Frame _____, or a true copy of the original assignment is attached.

OR

B. A chain of title from the inventor(s), of the patent application/patent identified above, to the current assignee as follows:

- 1. From: Xiaodong Li et al. To: Broadstorm Telecommunications, inc.
The document was recorded in the United States Patent and Trademark Office at Reel 017118, Frame 0553, or for which a copy thereof is attached.
- 2. From: Broadstorm Telecommunications, Inc. To: J & K Services L.L.C.
The document was recorded in the United States Patent and Trademark Office at Reel 017116, Frame 0568, or for which a copy thereof is attached.
- 3. From: J & K Services L.L.C. To: SDR Holdings, L.L.C.
The document was recorded in the United States Patent and Trademark Office at Reel 017115, Frame 0693, or for which a copy thereof is attached.

Additional documents in the chain of title are listed on a supplemental sheet.

As required by 37 CFR 3.73(b)(1)(i), the documentary evidence of the chain of title from the original owner to the assignee was, or concurrently is being, submitted for recordation pursuant to 37 CFR 3.11. (NOTE: A separate copy (i.e., a true copy of the original assignment document(s)) must be submitted to Assignment Division in accordance with 37 CFR Part 3, to record the assignment in the records of the USPTO. See MPEP 302.08)

The undersigned (whose title is supplied below) is authorized to act on behalf of the assignee.

[Signature]

Signature
Byron Young

Printed or Typed Name
Vice President Marketing & Product Management

Title

3/8/06

Date
(205) 384-2580

Telephone Number

STATEMENT UNDER 37 CFR 3.73(b) - Supplemental Sheet

Continuation of chain of title from the inventor(s) to the current assignee.

4. From: SDR Holdings, L.L.C. To: Kaon Systems, Inc.
The document was recorded in the United States Patent and Trademark Office at
Reel 017116 , Frame 0723 , or for which a copy thereof is attached.

5. From: SDR Holdings, L.L.C. To: Kaon Systems, Inc.
The document was recorded in the United States Patent and Trademark Office at
Reel 017116 , Frame 0790 , or for which a copy thereof is attached.

6. From: Kaon Systems, Inc. To: Adaptix, Inc.
The document was recorded in the United States Patent and Trademark Office at
Reel 017117 , Frame 0030 , or for which a copy thereof is attached.

7. From: _____ To: _____
The document was recorded in the United States Patent and Trademark Office at
Reel _____ , Frame _____ , or for which a copy thereof is attached.

8. From: _____ To: _____
The document was recorded in the United States Patent and Trademark Office at
Reel _____ , Frame _____ , or for which a copy thereof is attached.

9. From: _____ To: _____
The document was recorded in the United States Patent and Trademark Office at
Reel _____ , Frame _____ , or for which a copy thereof is attached.



UNITED STATES PATENT AND TRADEMARK OFFICE

UNITED STATES DEPARTMENT OF COMMERCE
United States Patent and Trademark Office
Address: COMMISSIONER FOR PATENTS
P.O. Box 1450
Alexandria, Virginia 22313-1450
www.uspto.gov

APPLICATION NUMBER	FILING OR 371(C) DATE	FIRST NAMED APPLICANT	ATTY. DOCKET NO./TITLE
11/199,586	08/08/2005	Xiaodong Li	68144/P014C1/10503148

CONFIRMATION NO. 1128

POA ACCEPTANCE LETTER

22882
MARTIN & FERRARO, LLP
1557 LAKE O'PINES STREET, NE
HARTVILLE, OH 44632



Date Mailed: 03/06/2012

NOTICE OF ACCEPTANCE OF POWER OF ATTORNEY

This is in response to the Power of Attorney filed 02/28/2012.

The Power of Attorney in this application is accepted. Correspondence in this application will be mailed to the above address as provided by 37 CFR 1.33.

/snguyen/

Office of Data Management, Application Assistance Unit (571) 272-4000, or (571) 272-4200, or 1-888-786-0101



UNITED STATES PATENT AND TRADEMARK OFFICE

UNITED STATES DEPARTMENT OF COMMERCE
United States Patent and Trademark Office
Address: COMMISSIONER FOR PATENTS
P.O. Box 1450
Alexandria, Virginia 22313-1450
www.uspto.gov

APPLICATION NUMBER	FILING OR 371(C) DATE	FIRST NAMED APPLICANT	ATTY. DOCKET NO./TITLE
11/199,586	08/08/2005	Xiaodong Li	68144/P014C1/10503148

29053
FULBRIGHT & JAWORSKI L.L.P
2200 ROSS AVENUE
SUITE 2800
DALLAS, TX 75201-2784

CONFIRMATION NO. 1128
POWER OF ATTORNEY NOTICE



Date Mailed: 03/06/2012

NOTICE REGARDING CHANGE OF POWER OF ATTORNEY

This is in response to the Power of Attorney filed 02/28/2012.

- The Power of Attorney to you in this application has been revoked by the assignee who has intervened as provided by 37 CFR 3.71. Future correspondence will be mailed to the new address of record(37 CFR 1.33).

/snguyen/

Office of Data Management, Application Assistance Unit (571) 272-4000, or (571) 272-4200, or 1-888-786-0101

AO 120 (Rev. 08/10)

TO: Mail Stop 8 Director of the U.S. Patent and Trademark Office P.O. Box 1450 Alexandria, VA 22313-1450	REPORT ON THE FILING OR DETERMINATION OF AN ACTION REGARDING A PATENT OR TRADEMARK
---	--

In Compliance with 35 U.S.C. § 290 and/or 15 U.S.C. § 1116 you are hereby advised that a court action has been filed in the U.S. District Court Eastern District of Texas on the following

Trademarks or Patents. (the patent action involves 35 U.S.C. § 292.);

DOCKET NO. 6:12cv20	DATE FILED 1/13/2012	U.S. DISTRICT COURT Eastern District of Texas
PLAINTIFF Adaptix, Inc.		DEFENDANT Pantech Wireless, Inc. and Celco Partnership d/b/a Verizon Wireless
PATENT OR TRADEMARK NO.	DATE OF PATENT OR TRADEMARK	HOLDER OF PATENT OR TRADEMARK
1 7,454,212	11/18/2008	Adaptix, Inc.
2 6,947,748	9/20/2005	Adaptix, Inc.
3		
4		
5		

In the above—entitled case, the following patent(s)/ trademark(s) have been included:

DATE INCLUDED	INCLUDED BY <input type="checkbox"/> Amendment <input type="checkbox"/> Answer <input type="checkbox"/> Cross Bill <input type="checkbox"/> Other Pleading		
PATENT OR TRADEMARK NO.	DATE OF PATENT OR TRADEMARK	HOLDER OF PATENT OR TRADEMARK	
1			
2			
3			
4			
5			

In the above—entitled case, the following decision has been rendered or judgement issued:

DECISION/JUDGEMENT

CLERK	(BY) DEPUTY CLERK	DATE
-------	-------------------	------

Copy 1—Upon initiation of action, mail this copy to Director Copy 3—Upon termination of action, mail this copy to Director
 Copy 2—Upon filing document adding patent(s), mail this copy to Director Copy 4—Case file copy

AO 120 (Rev. 08/10)

TO: Mail Stop 8 Director of the U.S. Patent and Trademark Office P.O. Box 1450 Alexandria, VA 22313-1450	REPORT ON THE FILING OR DETERMINATION OF AN ACTION REGARDING A PATENT OR TRADEMARK
---	---

In Compliance with 35 U.S.C. § 290 and/or 15 U.S.C. § 1116 you are hereby advised that a court action has been filed in the U.S. District Court Eastern District of Texas on the following

Trademarks or Patents. (the patent action involves 35 U.S.C. § 292.):

DOCKET NO. 6:12cv124	DATE FILED 3/9/2012	U.S. DISTRICT COURT Eastern District of Texas
PLAINTIFF Adaptix, Inc.		DEFENDANT Apple, Inc. and Cellco Partnership d/b/a Verizon Wireless
PATENT OR TRADEMARK NO.	DATE OF PATENT OR TRADEMARK	HOLDER OF PATENT OR TRADEMARK
1 7,454,212	11/18/2008	Adaptix, Inc.
2 6,947,748	9/20/2005	Adaptix, Inc.
3		
4		
5		

In the above—entitled case, the following patent(s)/ trademark(s) have been included:

DATE INCLUDED	INCLUDED BY <input type="checkbox"/> Amendment <input type="checkbox"/> Answer <input type="checkbox"/> Cross Bill <input type="checkbox"/> Other Pleading	
PATENT OR TRADEMARK NO.	DATE OF PATENT OR TRADEMARK	HOLDER OF PATENT OR TRADEMARK
1		
2		
3		
4		
5		

In the above—entitled case, the following decision has been rendered or judgement issued:

DECISION/JUDGEMENT

CLERK	(BY) DEPUTY CLERK	DATE
-------	-------------------	------

Copy 1—Upon initiation of action, mail this copy to Director Copy 3—Upon termination of action, mail this copy to Director
 Copy 2—Upon filing document adding patent(s), mail this copy to Director Copy 4—Case file copy

AO 120 (Rev. 08/10)

TO: Mail Stop 8 Director of the U.S. Patent and Trademark Office P.O. Box 1450 Alexandria, VA 22313-1450	REPORT ON THE FILING OR DETERMINATION OF AN ACTION REGARDING A PATENT OR TRADEMARK
---	---

In Compliance with 35 U.S.C. § 290 and/or 15 U.S.C. § 1116 you are hereby advised that a court action has been filed in the U.S. District Court Eastern District of Texas on the following

Trademarks or Patents. (the patent action involves 35 U.S.C. § 292.):

DOCKET NO. 6:12cv125	DATE FILED 3/9/2012	U.S. DISTRICT COURT Eastern District of Texas
PLAINTIFF Adaptix, Inc.		DEFENDANT Apple, Inc., AT&T, Inc. and AT&T Mobility LLC
PATENT OR TRADEMARK NO.	DATE OF PATENT OR TRADEMARK	HOLDER OF PATENT OR TRADEMARK
1 7,454,212	11/18/2008	Adaptix, Inc.
2 6,947,748	9/20/2005	Adaptix, Inc.
3		
4		
5		

In the above—entitled case, the following patent(s)/ trademark(s) have been included:

DATE INCLUDED	INCLUDED BY <input type="checkbox"/> Amendment <input type="checkbox"/> Answer <input type="checkbox"/> Cross Bill <input type="checkbox"/> Other Pleading	
PATENT OR TRADEMARK NO.	DATE OF PATENT OR TRADEMARK	HOLDER OF PATENT OR TRADEMARK
1		
2		
3		
4		
5		

In the above—entitled case, the following decision has been rendered or judgement issued:

DECISION/JUDGEMENT

CLERK	(BY) DEPUTY CLERK	DATE

Copy 1—Upon initiation of action, mail this copy to Director Copy 3—Upon termination of action, mail this copy to Director
 Copy 2—Upon filing document adding patent(s), mail this copy to Director Copy 4—Case file copy

AO 120 (Rev. 08/10)

TO: Mail Stop 8 Director of the U.S. Patent and Trademark Office P.O. Box 1450 Alexandria, VA 22313-1450	REPORT ON THE FILING OR DETERMINATION OF AN ACTION REGARDING A PATENT OR TRADEMARK
---	---

In Compliance with 35 U.S.C. § 290 and/or 15 U.S.C. § 1116 you are hereby advised that a court action has been filed in the U.S. District Court Eastern District of Texas on the following

Trademarks or Patents. (the patent action involves 35 U.S.C. § 292.):

DOCKET NO. 6:12cv120	DATE FILED 3/9/2012	U.S. DISTRICT COURT Eastern District of Texas
PLAINTIFF Adaptix, Inc.		DEFENDANT Cellco Partnership d/b/a Verizon Wireless, LG Electronics, Inc. and LG Electronics USA, Inc.
PATENT OR TRADEMARK NO.	DATE OF PATENT OR TRADEMARK	HOLDER OF PATENT OR TRADEMARK
1 7,454,212	11/18/2008	Adaptix, Inc.
2 6,947,748	9/20/2005	Adaptix, Inc.
3		
4		
5		

In the above—entitled case, the following patent(s)/ trademark(s) have been included:

DATE INCLUDED	INCLUDED BY <input type="checkbox"/> Amendment <input type="checkbox"/> Answer <input type="checkbox"/> Cross Bill <input type="checkbox"/> Other Pleading		
PATENT OR TRADEMARK NO.	DATE OF PATENT OR TRADEMARK	HOLDER OF PATENT OR TRADEMARK	
1			
2			
3			
4			
5			

In the above—entitled case, the following decision has been rendered or judgement issued:

DECISION/JUDGEMENT

CLERK	(BY) DEPUTY CLERK	DATE
-------	-------------------	------

Copy 1—Upon initiation of action, mail this copy to Director Copy 3—Upon termination of action, mail this copy to Director
 Copy 2—Upon filing document adding patent(s), mail this copy to Director Copy 4—Case file copy

AO 120 (Rev. 08/10)

TO: Mail Stop 8 Director of the U.S. Patent and Trademark Office P.O. Box 1450 Alexandria, VA 22313-1450	REPORT ON THE FILING OR DETERMINATION OF AN ACTION REGARDING A PATENT OR TRADEMARK
---	---

In Compliance with 35 U.S.C. § 290 and/or 15 U.S.C. § 1116 you are hereby advised that a court action has been filed in the U.S. District Court Eastern District of Texas on the following

Trademarks or Patents. (the patent action involves 35 U.S.C. § 292.);

DOCKET NO. 6:12cv121	DATE FILED 3/9/2012	U.S. DISTRICT COURT Eastern District of Texas
PLAINTIFF Adaptix, Inc.		DEFENDANT Cellco Partnership d/b/a Verizon Wireless, HTC Corporation, and HTC America, Inc.
PATENT OR TRADEMARK NO.	DATE OF PATENT OR TRADEMARK	HOLDER OF PATENT OR TRADEMARK
1 7,454,212	11/18/2008	Adaptix, Inc.
2 6,947,748	9/20/2005	Adaptix, Inc.
3		
4		
5		

In the above—entitled case, the following patent(s)/ trademark(s) have been included:

DATE INCLUDED	INCLUDED BY <input type="checkbox"/> Amendment <input type="checkbox"/> Answer <input type="checkbox"/> Cross Bill <input type="checkbox"/> Other Pleading	
PATENT OR TRADEMARK NO.	DATE OF PATENT OR TRADEMARK	HOLDER OF PATENT OR TRADEMARK
1		
2		
3		
4		
5		

In the above—entitled case, the following decision has been rendered or judgement issued:

DECISION/JUDGEMENT

CLERK	(BY) DEPUTY CLERK	DATE
-------	-------------------	------

Copy 1—Upon initiation of action, mail this copy to Director Copy 3—Upon termination of action, mail this copy to Director
 Copy 2—Upon filing document adding patent(s), mail this copy to Director Copy 4—Case file copy

AO 120 (Rev. 08/10)

TO: Mail Stop 8 Director of the U.S. Patent and Trademark Office P.O. Box 1450 Alexandria, VA 22313-1450	REPORT ON THE FILING OR DETERMINATION OF AN ACTION REGARDING A PATENT OR TRADEMARK
---	--

In Compliance with 35 U.S.C. § 290 and/or 15 U.S.C. § 1116 you are hereby advised that a court action has been filed in the U.S. District Court Eastern District of Texas on the following

Trademarks or Patents. (the patent action involves 35 U.S.C. § 292.):

DOCKET NO. 6:13-cv-28	DATE FILED 1/4/2013	U.S. DISTRICT COURT Eastern District of Texas
PLAINTIFF Adaptix, Inc.		DEFENDANT Apple, Inc., AT&T, Inc. and AT&T Mobility LLC
PATENT OR TRADEMARK NO.	DATE OF PATENT OR TRADEMARK	HOLDER OF PATENT OR TRADEMARK
1 7,454,212	11/18/2008	Adaptix, Inc.
2 6,947,748	9/20/2005	Adaptix, Inc.
3		
4		
5		

In the above—entitled case, the following patent(s)/ trademark(s) have been included:

DATE INCLUDED	INCLUDED BY <input type="checkbox"/> Amendment <input type="checkbox"/> Answer <input type="checkbox"/> Cross Bill <input type="checkbox"/> Other Pleading		
PATENT OR TRADEMARK NO.	DATE OF PATENT OR TRADEMARK	HOLDER OF PATENT OR TRADEMARK	
1			
2			
3			
4			
5			

In the above—entitled case, the following decision has been rendered or judgement issued:

DECISION/JUDGEMENT

CLERK	(BY) DEPUTY CLERK	DATE
-------	-------------------	------

Copy 1—Upon initiation of action, mail this copy to Director Copy 3—Upon termination of action, mail this copy to Director
 Copy 2—Upon filing document adding patent(s), mail this copy to Director Copy 4—Case file copy

IN THE UNITED STATES PATENT AND TRADEMARK OFFICE

In re Patent of:)	Confirmation No.: 1128
Xiaodong Li)	
Patent No.: 7,454,212)	(Serial No.: 11/199,586)
Issued: November 18, 2008)	(Filed: August 8, 2005)
For: OFDMA WITH ADAPTIVE)	
SUBCARRIER-CLUSTER)	08/01/2013 DALLEN 00000005 501068 7454212
CONFIGURATION AND)	01 FC:1599 1035.00 DA
SELECTIVE LOADING)	

Mail Stop M Correspondence
Commissioner for Patents
P.O. Box 1450
Alexandria, VA 22313-1450

Sir:

**CHANGE OF STATUS FROM SMALL ENTITY TO
LARGE ENTITY UNDER 37 C.F.R. § 1.28**

In the above-identified application, small entity status was established in good faith, although through error the Office was not notified of a loss of entitlement to small entity status. The present submission serves to correct this error. The itemization of the total amount of the deficiency is provided below:

<u>Fees Paid (Small Entity)</u>	<u>Date Paid</u>	<u>Large Entity Fee</u>	<u>Difference</u>
\$565	5/17/12	\$1,600	\$1,035
Total Amount of Deficiency = \$1,035			

Accordingly, please update the Office records to indicate the loss of small entity status and charge the total amount of the deficiency (\$1,035) to Deposit Account No. 50-1068.

Please charge any additional fees required to enter this paper to our Deposit Account No. 50-1068.

Respectfully submitted,
MARTIN & FERRARO, LLP

Dated: July 25, 2013

By: /Amedeo F. Ferraro/
Amedeo F. Ferraro
Registration No. 37,129

17383 Sunset Boulevard, Suite 250
Los Angeles, California 90272
Telephone: (310) 286-9800
Facsimile: (310) 286-2795

IN THE UNITED STATES PATENT AND TRADEMARK OFFICE

In re Patent of:) Confirmation No.: 1128
Xiaodong Li)
Patent No.: 7,454,212) (Serial No.: 11/199,586)
Issued: November 18, 2008) (Filed: August 8, 2005)
For: OFDMA WITH ADAPTIVE)
SUBCARRIER-CLUSTER)
CONFIGURATION AND)
SELECTIVE LOADING)

Mail Stop M Correspondence
Commissioner for Patents
P.O. Box 1450
Alexandria, VA 22313-1450

Sir:

**CHANGE OF STATUS FROM SMALL ENTITY TO
LARGE ENTITY UNDER 37 C.F.R. § 1.28**

In the above-identified application, small entity status was established in good faith, although through error the Office was not notified of a loss of entitlement to small entity status. The present submission serves to correct this error. The itemization of the total amount of the deficiency is provided below:

<u>Fees Paid (Small Entity)</u>	<u>Date Paid</u>	<u>Large Entity Fee</u>	<u>Difference</u>
\$565	5/17/12	\$1,600	\$1,035

Total Amount of Deficiency = \$1,035

Accordingly, please update the Office records to indicate the loss of small entity status and charge the total amount of the deficiency (\$1,035) to Deposit Account No. 50-1068.

Please charge any additional fees required to enter this paper to our Deposit Account No. 50-1068.

Respectfully submitted,
MARTIN & FERRARO, LLP

Dated: July 25, 2013

By: /Amedeo F. Ferraro/
Amedeo F. Ferraro
Registration No. 37,129

17383 Sunset Boulevard, Suite 250
Los Angeles, California 90272
Telephone: (310) 286-9800
Facsimile: (310) 286-2795

Electronic Acknowledgement Receipt

EFS ID:	16442403
Application Number:	11199586
International Application Number:	
Confirmation Number:	1128
Title of Invention:	OFDMA WITH ADAPTIVE SUBCARRIER-CLUSTER CONFIGURATION AND SELECTIVE LOADING
First Named Inventor/Applicant Name:	Xiaodong Li
Customer Number:	22882
Filer:	Amedeo F. Ferraro/Adrienne Krauss
Filer Authorized By:	Amedeo F. Ferraro
Attorney Docket Number:	176.0003-01000
Receipt Date:	29-JUL-2013
Filing Date:	08-AUG-2005
Time Stamp:	15:45:12
Application Type:	Utility under 35 USC 111(a)

Payment information:

Submitted with Payment	no
------------------------	----

File Listing:

Document Number	Document Description	File Name	File Size(Bytes)/ Message Digest	Multi Part /.zip	Pages (if appl.)
1	Notification of loss of entitlement to small entity status	Change_to_Large_Entity_Statu s.pdf	58961 <small>061bd233b6fce51d5d72a6f5cc462b1f32058042</small>	no	1

Warnings:

Information:

This Acknowledgement Receipt evidences receipt on the noted date by the USPTO of the indicated documents, characterized by the applicant, and including page counts, where applicable. It serves as evidence of receipt similar to a Post Card, as described in MPEP 503.

New Applications Under 35 U.S.C. 111

If a new application is being filed and the application includes the necessary components for a filing date (see 37 CFR 1.53(b)-(d) and MPEP 506), a Filing Receipt (37 CFR 1.54) will be issued in due course and the date shown on this Acknowledgement Receipt will establish the filing date of the application.

National Stage of an International Application under 35 U.S.C. 371

If a timely submission to enter the national stage of an international application is compliant with the conditions of 35 U.S.C. 371 and other applicable requirements a Form PCT/DO/EO/903 indicating acceptance of the application as a national stage submission under 35 U.S.C. 371 will be issued in addition to the Filing Receipt, in due course.

New International Application Filed with the USPTO as a Receiving Office

If a new international application is being filed and the international application includes the necessary components for an international filing date (see PCT Article 11 and MPEP 1810), a Notification of the International Application Number and of the International Filing Date (Form PCT/RO/105) will be issued in due course, subject to prescriptions concerning national security, and the date shown on this Acknowledgement Receipt will establish the international filing date of the application.

<p style="text-align: center;">Mail Stop 8 Director of the U.S. Patent and Trademark Office P.O. Box 1450 Alexandria, VA 22313-1450</p>	<p>REPORT ON THE FILING OR DETERMINATION OF AN ACTION REGARDING A PATENT OR TRADEMARK</p>
--	--

In Compliance with 35 U.S.C. § 290 and/or 15 U.S.C. § 1116 you are hereby advised that a court action has been filed in the U.S. District Court Eastern District of Texas, Tyler Division on the following

Trademarks or Patents. (the patent action involves 35 U.S.C. § 292.);

DOCKET NO. 6:13-cv-00424	DATE FILED 5/24/2013	U.S. DISTRICT COURT Eastern District of Texas, Tyler Division
PLAINTIFF ADAPTIX, Inc.		DEFENDANT PANTECH COMPANY LIMITED, PANTECH INC. d/b/a PANTECH USA and CELLCO PARTNERSHIP d/b/a VERIZON WIRELESS
PATENT OR TRADEMARK NO.	DATE OF PATENT OR TRADEMARK	HOLDER OF PATENT OR TRADEMARK
1 7,454,212	11/18/2008	ADAPTIX, Inc.
2 6,947,748	9/20/2005	ADAPTIX, Inc.
3		
4		
5		

In the above—entitled case, the following patent(s)/ trademark(s) have been included:

DATE INCLUDED	INCLUDED BY <input type="checkbox"/> Amendment <input type="checkbox"/> Answer <input type="checkbox"/> Cross Bill <input type="checkbox"/> Other Pleading	
PATENT OR TRADEMARK NO.	DATE OF PATENT OR TRADEMARK	HOLDER OF PATENT OR TRADEMARK
1		
2		
3		
4		
5		

In the above—entitled case, the following decision has been rendered or judgement issued:

CLERK	(BY) DEPUTY CLERK	DATE
-------	-------------------	------

Copy 1—Upon initiation of action, mail this copy to Director Copy 3—Upon termination of action, mail this copy to Director
 Copy 2—Upon filing document adding patent(s), mail this copy to Director Copy 4—Case file copy

TO: Mail Stop 8 Director of the U.S. Patent and Trademark Office P.O. Box 1450 Alexandria, VA 22313-1450	REPORT ON THE FILING OR DETERMINATION OF AN ACTION REGARDING A PATENT OR TRADEMARK
---	---

In Compliance with 35 U.S.C. § 290 and/or 15 U.S.C. § 1116 you are hereby advised that a court action has been filed in the U.S. District Court Eastern District of Texas, Tyler Division on the following

Trademarks or Patents. (the patent action involves 35 U.S.C. § 292.):

DOCKET NO. 6:13-cv-444	DATE FILED 5/28/2013	U.S. DISTRICT COURT Eastern District of Texas, Tyler Division
PLAINTIFF ADAPTIX, Inc.		DEFENDANT ZTE Corporation, ZTE USA, Inc., ZTE Solutions, Inc. and Sprint Spectrum L.P.
PATENT OR TRADEMARK NO.	DATE OF PATENT OR TRADEMARK	HOLDER OF PATENT OR TRADEMARK
1 7,454,212	11/18/2008	ADAPTIX, Inc.
2 6,947,748	9/20/2005	ADAPTIX, Inc.
3		
4		
5		

In the above—entitled case, the following patent(s)/ trademark(s) have been included:

DATE INCLUDED	INCLUDED BY <input type="checkbox"/> Amendment <input type="checkbox"/> Answer <input type="checkbox"/> Cross Bill <input type="checkbox"/> Other Pleading	
PATENT OR TRADEMARK NO.	DATE OF PATENT OR TRADEMARK	HOLDER OF PATENT OR TRADEMARK
1		
2		
3		
4		
5		

In the above—entitled case, the following decision has been rendered or judgement issued:

DECISION/JUDGEMENT

CLERK	(BY) DEPUTY CLERK	DATE
-------	-------------------	------

Copy 1—Upon initiation of action, mail this copy to Director Copy 3—Upon termination of action, mail this copy to Director
 Copy 2—Upon filing document adding patent(s), mail this copy to Director Copy 4—Case file copy

TO: Mail Stop 8 Director of the U.S. Patent and Trademark Office P.O. Box 1450 Alexandria, VA 22313-1450	REPORT ON THE FILING OR DETERMINATION OF AN ACTION REGARDING A PATENT OR TRADEMARK
---	---

In Compliance with 35 U.S.C. § 290 and/or 15 U.S.C. § 1116 you are hereby advised that a court action has been filed in the U.S. District Court Eastern District of Texas, Tyler Division on the following

Trademarks or Patents. (the patent action involves 35 U.S.C. § 292.):

DOCKET NO. 6:13-cv-441	DATE FILED 5/28/2013	U.S. DISTRICT COURT Eastern District of Texas, Tyler Division
PLAINTIFF ADAPTIX, Inc.		DEFENDANT Huawei Technologies Co., Ltd., Huawei Technologies USA, Inc., Huawei Devices USA, Inc. and U.S. Cellular Corporation d/b/a U.S. Cellular
PATENT OR TRADEMARK NO.	DATE OF PATENT OR TRADEMARK	HOLDER OF PATENT OR TRADEMARK
1 7,454,212	11/18/2008	ADAPTIX, Inc.
2 6,947,748	9/20/2005	ADAPTIX, Inc.
3		
4		
5		

In the above—entitled case, the following patent(s)/ trademark(s) have been included:

DATE INCLUDED	INCLUDED BY <input type="checkbox"/> Amendment <input type="checkbox"/> Answer <input type="checkbox"/> Cross Bill <input type="checkbox"/> Other Pleading	
PATENT OR TRADEMARK NO.	DATE OF PATENT OR TRADEMARK	HOLDER OF PATENT OR TRADEMARK
1		
2		
3		
4		
5		

In the above—entitled case, the following decision has been rendered or judgement issued:

DECISION/JUDGEMENT

CLERK	(BY) DEPUTY CLERK	DATE
-------	-------------------	------

Copy 1—Upon initiation of action, mail this copy to Director Copy 3—Upon termination of action, mail this copy to Director
 Copy 2—Upon filing document adding patent(s), mail this copy to Director Copy 4—Case file copy

TO: Mail Stop 8 Director of the U.S. Patent and Trademark Office P.O. Box 1450 Alexandria, VA 22313-1450	REPORT ON THE FILING OR DETERMINATION OF AN ACTION REGARDING A PATENT OR TRADEMARK
--	---

In Compliance with 35 U.S.C. § 290 and/or 15 U.S.C. § 1116 you are hereby advised that a court action has been filed in the U.S. District Court Eastern District of Texas, Tyler Division on the following

Trademarks or Patents. (the patent action involves 35 U.S.C. § 292.):

DOCKET NO. 6:13-cv-434	DATE FILED 5/28/2013	U.S. DISTRICT COURT Eastern District of Texas, Tyler Division
PLAINTIFF ADAPTIX, Inc.		DEFENDANT Research In Motion Limited, Research In Motion Corporation, and Blackberry USA f/k/a Research In Motion Limited, and AT&T, Inc. and AT&T Mobility LLC
PATENT OR TRADEMARK NO.	DATE OF PATENT OR TRADEMARK	HOLDER OF PATENT OR TRADEMARK
1 7,454,212	11/18/2008	ADAPTIX, Inc.
2 6,947,748	9/20/2005	ADAPTIX, Inc.
3		
4		
5		

In the above—entitled case, the following patent(s)/ trademark(s) have been included:

DATE INCLUDED	INCLUDED BY <input type="checkbox"/> Amendment <input type="checkbox"/> Answer <input type="checkbox"/> Cross Bill <input type="checkbox"/> Other Pleading	
PATENT OR TRADEMARK NO.	DATE OF PATENT OR TRADEMARK	HOLDER OF PATENT OR TRADEMARK
1		
2		
3		
4		
5		

In the above—entitled case, the following decision has been rendered or judgement issued:

DECISION/JUDGEMENT

CLERK	(BY) DEPUTY CLERK	DATE
-------	-------------------	------

Copy 1—Upon initiation of action, mail this copy to Director Copy 3—Upon termination of action, mail this copy to Director
 Copy 2—Upon filing document adding patent(s), mail this copy to Director Copy 4—Case file copy

<p>TO: Mail Stop 8 Director of the U.S. Patent and Trademark Office P.O. Box 1450 Alexandria, VA 22313-1450</p>	<p>REPORT ON THE FILING OR DETERMINATION OF AN ACTION REGARDING A PATENT OR TRADEMARK</p>
---	--

In Compliance with 35 U.S.C. § 290 and/or 15 U.S.C. § 1116 you are hereby advised that a court action has been filed in the U.S. District Court Eastern District of Texas, Tyler Division on the following

Trademarks or Patents. (the patent action involves 35 U.S.C. § 292.);

DOCKET NO. 6:13-cv-435	DATE FILED 5/28/2013	U.S. DISTRICT COURT Eastern District of Texas, Tyler Division
PLAINTIFF ADAPTIX, Inc.		DEFENDANT Research In Motion Limited, Research In Motion Corporation, Blackberry USA f/k/a Research In Motion Limited, T-Mobile USA, Inc. f/k/a MetroPCS Wireless, Inc. and MetroPCS USA Communications, Inc.
PATENT OR TRADEMARK NO.	DATE OF PATENT OR TRADEMARK	HOLDER OF PATENT OR TRADEMARK
1 7,454,212	11/18/2008	ADAPTIX, Inc.
2 6,947,748	9/20/2005	ADAPTIX, Inc.
3		
4		
5		

In the above—entitled case, the following patent(s)/ trademark(s) have been included:

DATE INCLUDED	INCLUDED BY <input type="checkbox"/> Amendment <input type="checkbox"/> Answer <input type="checkbox"/> Cross Bill <input type="checkbox"/> Other Pleading	
PATENT OR TRADEMARK NO.	DATE OF PATENT OR TRADEMARK	HOLDER OF PATENT OR TRADEMARK
1		
2		
3		
4		
5		

In the above—entitled case, the following decision has been rendered or judgement issued:

DECISION/JUDGEMENT

CLERK	(BY) DEPUTY CLERK	DATE
-------	-------------------	------

Copy 1—Upon initiation of action, mail this copy to Director Copy 3—Upon termination of action, mail this copy to Director
 Copy 2—Upon filing document adding patent(s), mail this copy to Director Copy 4—Case file copy

TO: Mail Stop 8 Director of the U.S. Patent and Trademark Office P.O. Box 1450 Alexandria, VA 22313-1450	REPORT ON THE FILING OR DETERMINATION OF AN ACTION REGARDING A PATENT OR TRADEMARK
--	---

In Compliance with 35 U.S.C. § 290 and/or 15 U.S.C. § 1116 you are hereby advised that a court action has been filed in the U.S. District Court Eastern District of Texas, Tyler Division on the following

Trademarks or Patents. (the patent action involves 35 U.S.C. § 292.):

DOCKET NO. 6:13-cv-442	DATE FILED 5/28/2013	U.S. DISTRICT COURT Eastern District of Texas, Tyler Division
PLAINTIFF ADAPTIX, Inc.		DEFENDANT Sony Mobile Communications, Inc., Sony Corporation of America, and Sony Mobile Communications (USA), Inc., AT&T, Inc., and AT&T Mobility LLC
PATENT OR TRADEMARK NO.	DATE OF PATENT OR TRADEMARK	HOLDER OF PATENT OR TRADEMARK
1 7,454,212	11/18/2008	ADAPTIX, Inc.
2 6,947,748	9/20/2005	ADAPTIX, Inc.
3		
4		
5		

In the above—entitled case, the following patent(s)/ trademark(s) have been included:

DATE INCLUDED	INCLUDED BY <input type="checkbox"/> Amendment <input type="checkbox"/> Answer <input type="checkbox"/> Cross Bill <input type="checkbox"/> Other Pleading	
PATENT OR TRADEMARK NO.	DATE OF PATENT OR TRADEMARK	HOLDER OF PATENT OR TRADEMARK
1		
2		
3		
4		
5		

In the above—entitled case, the following decision has been rendered or judgement issued:

DECISION/JUDGEMENT

CLERK	(BY) DEPUTY CLERK	DATE
-------	-------------------	------

Copy 1—Upon initiation of action, mail this copy to Director Copy 3—Upon termination of action, mail this copy to Director
 Copy 2—Upon filing document adding patent(s), mail this copy to Director Copy 4—Case file copy

TO: Mail Stop 8 Director of the U.S. Patent and Trademark Office P.O. Box 1450 Alexandria, VA 22313-1450	REPORT ON THE FILING OR DETERMINATION OF AN ACTION REGARDING A PATENT OR TRADEMARK
---	---

In Compliance with 35 U.S.C. § 290 and/or 15 U.S.C. § 1116 you are hereby advised that a court action has been filed in the U.S. District Court Eastern District of Texas, Tyler Division on the following

Trademarks or Patents. (the patent action involves 35 U.S.C. § 292.):

DOCKET NO. 6:13-cv-438	DATE FILED 5/28/2013	U.S. DISTRICT COURT Eastern District of Texas, Tyler Division
PLAINTIFF ADAPTIX, Inc.		DEFENDANT Huawei Technologies Co., Ltd., Huawei Technologies USA, Inc., Huawei Devices USA, Inc. and Cricket Communications, Inc. d/b/a Cricket Wireless
PATENT OR TRADEMARK NO.	DATE OF PATENT OR TRADEMARK	HOLDER OF PATENT OR TRADEMARK
1 7,454,212	11/18/2008	ADAPTIX, Inc.
2 6,947,748	9/20/2005	ADAPTIX, Inc.
3		
4		
5		

In the above—entitled case, the following patent(s)/ trademark(s) have been included:

DATE INCLUDED	INCLUDED BY <input type="checkbox"/> Amendment <input type="checkbox"/> Answer <input type="checkbox"/> Cross Bill <input type="checkbox"/> Other Pleading	
PATENT OR TRADEMARK NO.	DATE OF PATENT OR TRADEMARK	HOLDER OF PATENT OR TRADEMARK
1		
2		
3		
4		
5		

In the above—entitled case, the following decision has been rendered or judgement issued:

DECISION/JUDGEMENT

CLERK	(BY) DEPUTY CLERK	DATE
-------	-------------------	------

Copy 1—Upon initiation of action, mail this copy to Director Copy 3—Upon termination of action, mail this copy to Director
 Copy 2—Upon filing document adding patent(s), mail this copy to Director Copy 4—Case file copy

TO: Mail Stop 8 Director of the U.S. Patent and Trademark Office P.O. Box 1450 Alexandria, VA 22313-1450	REPORT ON THE FILING OR DETERMINATION OF AN ACTION REGARDING A PATENT OR TRADEMARK
---	---

In Compliance with 35 U.S.C. § 290 and/or 15 U.S.C. § 1116 you are hereby advised that a court action has been filed in the U.S. District Court Eastern District of Texas, Tyler Division on the following

Trademarks or Patents. (the patent action involves 35 U.S.C. § 292.):

DOCKET NO. 6:13-cv-432	DATE FILED 5/28/2013	U.S. DISTRICT COURT Eastern District of Texas, Tyler Division
PLAINTIFF ADAPTIX, Inc.		DEFENDANT Amazon.com, Inc., AT&T, Inc. and AT&T Mobility LLC
PATENT OR TRADEMARK NO.	DATE OF PATENT OR TRADEMARK	HOLDER OF PATENT OR TRADEMARK
1 7,454,212	11/18/2008	ADAPTIX, Inc.
2 6,947,748	9/20/2005	ADAPTIX, Inc.
3		
4		
5		

In the above—entitled case, the following patent(s)/ trademark(s) have been included:

DATE INCLUDED	INCLUDED BY	
	<input type="checkbox"/> Amendment <input type="checkbox"/> Answer <input type="checkbox"/> Cross Bill <input type="checkbox"/> Other Pleading	
PATENT OR TRADEMARK NO.	DATE OF PATENT OR TRADEMARK	HOLDER OF PATENT OR TRADEMARK
1		
2		
3		
4		
5		

In the above—entitled case, the following decision has been rendered or judgement issued:

DECISION/JUDGEMENT

CLERK	(BY) DEPUTY CLERK	DATE
-------	-------------------	------

Copy 1—Upon initiation of action, mail this copy to Director Copy 3—Upon termination of action, mail this copy to Director
Copy 2—Upon filing document adding patent(s), mail this copy to Director Copy 4—Case file copy

TO: Mail Stop 8 Director of the U.S. Patent and Trademark Office P.O. Box 1450 Alexandria, VA 22313-1450	REPORT ON THE FILING OR DETERMINATION OF AN ACTION REGARDING A PATENT OR TRADEMARK
--	---

In Compliance with 35 U.S.C. § 290 and/or 15 U.S.C. § 1116 you are hereby advised that a court action has been filed in the U.S. District Court Eastern District of Texas, Tyler Division on the following

Trademarks or Patents. (the patent action involves 35 U.S.C. § 292.):

DOCKET NO. 6:13-cv-436	DATE FILED 5/28/2013	U.S. DISTRICT COURT Eastern District of Texas, Tyler Division
PLAINTIFF ADAPTIX, Inc.		DEFENDANT Research In Motion Limited, Research In Motion Corporation, Blackberry USA f/k/a Research In Motion Limited and Cellco Partnership d/b/a Verizon Wireless
PATENT OR TRADEMARK NO.	DATE OF PATENT OR TRADEMARK	HOLDER OF PATENT OR TRADEMARK
1 7,454,212	11/18/2008	ADAPTIX, Inc.
2 6,947,748	9/20/2005	ADAPTIX, Inc.
3		
4		
5		

In the above—entitled case, the following patent(s)/ trademark(s) have been included:

DATE INCLUDED	INCLUDED BY <input type="checkbox"/> Amendment <input type="checkbox"/> Answer <input type="checkbox"/> Cross Bill <input type="checkbox"/> Other Pleading	
PATENT OR TRADEMARK NO.	DATE OF PATENT OR TRADEMARK	HOLDER OF PATENT OR TRADEMARK
1		
2		
3		
4		
5		

In the above—entitled case, the following decision has been rendered or judgement issued:

DECISION/JUDGEMENT

CLERK	(BY) DEPUTY CLERK	DATE
-------	-------------------	------

Copy 1—Upon initiation of action, mail this copy to Director Copy 3—Upon termination of action, mail this copy to Director
 Copy 2—Upon filing document adding patent(s), mail this copy to Director Copy 4—Case file copy

TO: Mail Stop 8 Director of the U.S. Patent and Trademark Office P.O. Box 1450 Alexandria, VA 22313-1450	REPORT ON THE FILING OR DETERMINATION OF AN ACTION REGARDING A PATENT OR TRADEMARK
---	---

In Compliance with 35 U.S.C. § 290 and/or 15 U.S.C. § 1116 you are hereby advised that a court action has been filed in the U.S. District Court Eastern District of Texas, Tyler Division on the following

Trademarks or Patents. (the patent action involves 35 U.S.C. § 292.):

DOCKET NO. 6:13-cv-437	DATE FILED 5/28/2013	U.S. DISTRICT COURT Eastern District of Texas, Tyler Division
PLAINTIFF ADAPTIX, Inc.		DEFENDANT Dell, Inc. and Cellco Partnership d/b/a Verizon Wireless
PATENT OR TRADEMARK NO.	DATE OF PATENT OR TRADEMARK	HOLDER OF PATENT OR TRADEMARK
1 7,454,212	11/18/2008	ADAPTIX, Inc.
2 6,947,748	9/20/2005	ADAPTIX, Inc.
3		
4		
5		

In the above—entitled case, the following patent(s)/ trademark(s) have been included:

DATE INCLUDED	INCLUDED BY <input type="checkbox"/> Amendment <input type="checkbox"/> Answer <input type="checkbox"/> Cross Bill <input type="checkbox"/> Other Pleading	
PATENT OR TRADEMARK NO.	DATE OF PATENT OR TRADEMARK	HOLDER OF PATENT OR TRADEMARK
1		
2		
3		
4		
5		

In the above—entitled case, the following decision has been rendered or judgement issued:

DECISION/JUDGEMENT

CLERK	(BY) DEPUTY CLERK	DATE
-------	-------------------	------

Copy 1—Upon initiation of action, mail this copy to Director Copy 3—Upon termination of action, mail this copy to Director
 Copy 2—Upon filing document adding patent(s), mail this copy to Director Copy 4—Case file copy

TO: Mail Stop 8 Director of the U.S. Patent and Trademark Office P.O. Box 1450 Alexandria, VA 22313-1450	REPORT ON THE FILING OR DETERMINATION OF AN ACTION REGARDING A PATENT OR TRADEMARK
--	---

In Compliance with 35 U.S.C. § 290 and/or 15 U.S.C. § 1116 you are hereby advised that a court action has been filed in the U.S. District Court Eastern District of Texas, Tyler Division on the following

Trademarks or Patents. (the patent action involves 35 U.S.C. § 292.):

DOCKET NO. 6:13-cv-443	DATE FILED 5/28/2013	U.S. DISTRICT COURT Eastern District of Texas, Tyler Division
PLAINTIFF ADAPTIX, Inc.		DEFENDANT ZTE Corporation, ZTE USA, Inc., ZTE Solutions, Inc. and Boost Mobile, LLC
PATENT OR TRADEMARK NO.	DATE OF PATENT OR TRADEMARK	HOLDER OF PATENT OR TRADEMARK
1 7,454,212	11/18/2008	ADAPTIX, Inc.
2 6,947,748	9/20/2005	ADAPTIX, Inc.
3		
4		
5		

In the above—entitled case, the following patent(s)/ trademark(s) have been included:

DATE INCLUDED	INCLUDED BY	
	<input type="checkbox"/> Amendment <input type="checkbox"/> Answer <input type="checkbox"/> Cross Bill <input type="checkbox"/> Other Pleading	
PATENT OR TRADEMARK NO.	DATE OF PATENT OR TRADEMARK	HOLDER OF PATENT OR TRADEMARK
1		
2		
3		
4		
5		

In the above—entitled case, the following decision has been rendered or judgement issued:

DECISION/JUDGEMENT

CLERK	(BY) DEPUTY CLERK	DATE

Copy 1—Upon initiation of action, mail this copy to Director Copy 3—Upon termination of action, mail this copy to Director
 Copy 2—Upon filing document adding patent(s), mail this copy to Director Copy 4—Case file copy

<p>TO: Mail Stop 8 Director of the U.S. Patent and Trademark Office P.O. Box 1450 Alexandria, VA 22313-1450</p>	<p>REPORT ON THE FILING OR DETERMINATION OF AN ACTION REGARDING A PATENT OR TRADEMARK</p>
---	--

In Compliance with 35 U.S.C. § 290 and/or 15 U.S.C. § 1116 you are hereby advised that a court action has been filed in the U.S. District Court Eastern District of Texas, Tyler Division on the following

Trademarks or Patents. (the patent action involves 35 U.S.C. § 292.):

DOCKET NO. 6:13-cv-439	DATE FILED 5/28/2013	U.S. DISTRICT COURT Eastern District of Texas, Tyler Division
PLAINTIFF ADAPTIX, Inc.		DEFENDANT Huawei Technologies Co., Ltd., Huawei Technologies USA, Inc., Huawei Devices USA, Inc. and Mosaic Telecommunications, LLC a/k/a Mosaic Telecom, f/k/a Chibardun Telephone Cooperative and CTC Teleco
PATENT OR TRADEMARK NO.	DATE OF PATENT OR TRADEMARK	HOLDER OF PATENT OR TRADEMARK
1 7,454,212	11/18/2008	ADAPTIX, Inc.
2 6,947,748	9/20/2005	ADAPTIX, Inc.
3		
4		
5		

In the above—entitled case, the following patent(s)/ trademark(s) have been included:

DATE INCLUDED	INCLUDED BY	
	<input type="checkbox"/> Amendment <input type="checkbox"/> Answer <input type="checkbox"/> Cross Bill <input type="checkbox"/> Other Pleading	
PATENT OR TRADEMARK NO.	DATE OF PATENT OR TRADEMARK	HOLDER OF PATENT OR TRADEMARK
1		
2		
3		
4		
5		

In the above—entitled case, the following decision has been rendered or judgement issued:

DECISION/JUDGEMENT

CLERK	(BY) DEPUTY CLERK	DATE
-------	-------------------	------

Copy 1—Upon initiation of action, mail this copy to Director Copy 3—Upon termination of action, mail this copy to Director
 Copy 2—Upon filing document adding patent(s), mail this copy to Director Copy 4—Case file copy

TO: Mail Stop 8 Director of the U.S. Patent and Trademark Office P.O. Box 1450 Alexandria, VA 22313-1450	REPORT ON THE FILING OR DETERMINATION OF AN ACTION REGARDING A PATENT OR TRADEMARK
---	---

In Compliance with 35 U.S.C. § 290 and/or 15 U.S.C. § 1116 you are hereby advised that a court action has been filed in the U.S. District Court Eastern District of Texas, Tyler Division on the following

Trademarks or Patents. (the patent action involves 35 U.S.C. § 292.):

DOCKET NO. 6:13-cv-445	DATE FILED 5/28/2013	U.S. DISTRICT COURT Eastern District of Texas, Tyler Division
PLAINTIFF ADAPTIX, Inc.		DEFENDANT ZTE Corporation, ZTE USA, Inc., and ZTE Solutions, Inc., T-Mobile USA, Inc. f/k/a MetroPCS Wireless, Inc., MetroPCS USA Communications, Inc.
PATENT OR TRADEMARK NO.	DATE OF PATENT OR TRADEMARK	HOLDER OF PATENT OR TRADEMARK
1 7,454,212	11/18/2008	ADAPTIX, Inc.
2 6,947,748	9/20/2005	ADAPTIX, Inc.
3		
4		
5		

In the above—entitled case, the following patent(s)/ trademark(s) have been included:

DATE INCLUDED	INCLUDED BY <input type="checkbox"/> Amendment <input type="checkbox"/> Answer <input type="checkbox"/> Cross Bill <input type="checkbox"/> Other Pleading	
PATENT OR TRADEMARK NO.	DATE OF PATENT OR TRADEMARK	HOLDER OF PATENT OR TRADEMARK
1		
2		
3		
4		
5		

In the above—entitled case, the following decision has been rendered or judgement issued:

DECISION/JUDGEMENT

CLERK	(BY) DEPUTY CLERK	DATE
-------	-------------------	------

Copy 1—Upon initiation of action, mail this copy to Director Copy 3—Upon termination of action, mail this copy to Director
 Copy 2—Upon filing document adding patent(s), mail this copy to Director Copy 4—Case file copy

TO: Mail Stop 8 Director of the U.S. Patent and Trademark Office P.O. Box 1450 Alexandria, VA 22313-1450	REPORT ON THE FILING OR DETERMINATION OF AN ACTION REGARDING A PATENT OR TRADEMARK
---	---

In Compliance with 35 U.S.C. § 290 and/or 15 U.S.C. § 1116 you are hereby advised that a court action has been filed in the U.S. District Court Eastern District of Texas, Tyler Division on the following

Trademarks or Patents. (the patent action involves 35 U.S.C. § 292.):

DOCKET NO. 6:13-cv-446	DATE FILED 5/28/2013	U.S. DISTRICT COURT Eastern District of Texas, Tyler Division
PLAINTIFF ADAPTIX, Inc.		DEFENDANT ZTE Corporation, ZTE USA, Inc., ZTE Solutions, Inc., and U.S. Cellular Corporation d/b/a U.S. Cellular
PATENT OR TRADEMARK NO.	DATE OF PATENT OR TRADEMARK	HOLDER OF PATENT OR TRADEMARK
1 7,454,212	11/18/2008	ADAPTIX, Inc.
2 6,947,748	9/20/2005	ADAPTIX, Inc.
3		
4		
5		

In the above—entitled case, the following patent(s)/ trademark(s) have been included:

DATE INCLUDED	INCLUDED BY <input type="checkbox"/> Amendment <input type="checkbox"/> Answer <input type="checkbox"/> Cross Bill <input type="checkbox"/> Other Pleading	
PATENT OR TRADEMARK NO.	DATE OF PATENT OR TRADEMARK	HOLDER OF PATENT OR TRADEMARK
1		
2		
3		
4		
5		

In the above—entitled case, the following decision has been rendered or judgement issued:

DECISION/JUDGEMENT

CLERK	(BY) DEPUTY CLERK	DATE
-------	-------------------	------

Copy 1—Upon initiation of action, mail this copy to Director Copy 3—Upon termination of action, mail this copy to Director
Copy 2—Upon filing document adding patent(s), mail this copy to Director Copy 4—Case file copy

TO: Mail Stop 8 Director of the U.S. Patent and Trademark Office P.O. Box 1450 Alexandria, VA 22313-1450	REPORT ON THE FILING OR DETERMINATION OF AN ACTION REGARDING A PATENT OR TRADEMARK
--	---

In Compliance with 35 U.S.C. § 290 and/or 15 U.S.C. § 1116 you are hereby advised that a court action has been filed in the U.S. District Court Eastern District of Texas, Tyler Division on the following

Trademarks or Patents. (the patent action involves 35 U.S.C. § 292.):

DOCKET NO. 6:13-cv-440	DATE FILED 5/28/2013	U.S. DISTRICT COURT Eastern District of Texas, Tyler Division
PLAINTIFF ADAPTIX, Inc.		DEFENDANT Huawei Technologies Co., Ltd., Huawei Technologies USA, Inc., Huawei Devices USA, Inc., T-Mobile USA, Inc. f/k/a MetroPCS Wireless, Inc. and MetroPCS USA Communications, Inc.
PATENT OR TRADEMARK NO.	DATE OF PATENT OR TRADEMARK	HOLDER OF PATENT OR TRADEMARK
1 7,454,212	11/18/2008	ADAPTIX, Inc.
2 6,947,748	9/20/2005	ADAPTIX, Inc.
3		
4		
5		

In the above—entitled case, the following patent(s)/ trademark(s) have been included:

DATE INCLUDED	INCLUDED BY <input type="checkbox"/> Amendment <input type="checkbox"/> Answer <input type="checkbox"/> Cross Bill <input type="checkbox"/> Other Pleading	
PATENT OR TRADEMARK NO.	DATE OF PATENT OR TRADEMARK	HOLDER OF PATENT OR TRADEMARK
1		
2		
3		
4		
5		

In the above—entitled case, the following decision has been rendered or judgement issued:

DECISION/JUDGEMENT

CLERK	(BY) DEPUTY CLERK	DATE
-------	-------------------	------

Copy 1—Upon initiation of action, mail this copy to Director Copy 3—Upon termination of action, mail this copy to Director
 Copy 2—Upon filing document adding patent(s), mail this copy to Director Copy 4—Case file copy

TO: Mail Stop 8 Director of the U.S. Patent and Trademark Office P.O. Box 1450 Alexandria, VA 22313-1450	REPORT ON THE FILING OR DETERMINATION OF AN ACTION REGARDING A PATENT OR TRADEMARK
---	---

In Compliance with 35 U.S.C. § 290 and/or 15 U.S.C. § 1116 you are hereby advised that a court action has been filed in the U.S. District Court Eastern District of Texas, Tyler Division on the following

Trademarks or Patents. (the patent action involves 35 U.S.C. § 292.):

DOCKET NO. 6:13-cv-433	DATE FILED 5/28/2013	U.S. DISTRICT COURT Eastern District of Texas, Tyler Division
PLAINTIFF ADAPTIX, Inc.		DEFENDANT ASUSTek and ASUS Computer International AT&T, Inc. and AT&T Mobility LLC
PATENT OR TRADEMARK NO.	DATE OF PATENT OR TRADEMARK	HOLDER OF PATENT OR TRADEMARK
1 7,454,212	11/18/2008	ADAPTIX, Inc.
2 6,947,748	9/20/2005	ADAPTIX, Inc.
3		
4		
5		

In the above—entitled case, the following patent(s)/ trademark(s) have been included:

DATE INCLUDED	INCLUDED BY	
	<input type="checkbox"/> Amendment <input type="checkbox"/> Answer <input type="checkbox"/> Cross Bill <input type="checkbox"/> Other Pleading	
PATENT OR TRADEMARK NO.	DATE OF PATENT OR TRADEMARK	HOLDER OF PATENT OR TRADEMARK
1		
2		
3		
4		
5		

In the above—entitled case, the following decision has been rendered or judgement issued:

DECISION/JUDGEMENT

CLERK	(BY) DEPUTY CLERK	DATE
-------	-------------------	------

TO: Mail Stop 8 Director of the U.S. Patent and Trademark Office P.O. Box 1450 Alexandria, VA 22313-1450	REPORT ON THE FILING OR DETERMINATION OF AN ACTION REGARDING A PATENT OR TRADEMARK
---	--

In Compliance with 35 U.S.C. § 290 and/or 15 U.S.C. § 1116 you are hereby advised that a court action has been filed in the U.S. District Court Eastern District of Texas, Tyler Division on the following

Trademarks or Patents. (the patent action involves 35 U.S.C. § 292.);

DOCKET NO. 6:13-cv-00585	DATE FILED 8/7/2013	U.S. DISTRICT COURT Eastern District of Texas, Tyler Division
PLAINTIFF ADAPTIX, Inc.		DEFENDANT NEC CASIO MOBILE COMMUNICATIONS, LTD., NEC CORPORATION OF AMERICA, T&T MOBILITY LLC, CELLCO PARTNERSHIP d/b/a VERIZON WIRELESS
PATENT OR TRADEMARK NO.	DATE OF PATENT OR TRADEMARK	HOLDER OF PATENT OR TRADEMARK
1 7,454,212	11/18/2008	ADAPTIX, Inc.
2 6,947,748	9/20/2005	ADAPTIX, Inc.
3		
4		
5		

In the above—entitled case, the following patent(s)/ trademark(s) have been included:

DATE INCLUDED	INCLUDED BY
	<input type="checkbox"/> Amendment <input type="checkbox"/> Answer <input type="checkbox"/> Cross Bill <input type="checkbox"/> Other Pleading
PATENT OR TRADEMARK NO.	DATE OF PATENT OR TRADEMARK
1	
2	
3	
4	
5	

In the above—entitled case, the following decision has been rendered or judgement issued:

DECISION/JUDGEMENT

CLERK	(BY) DEPUTY CLERK	DATE
-------	-------------------	------

Copy 1—Upon initiation of action, mail this copy to Director Copy 3—Upon termination of action, mail this copy to Director
 Copy 2—Upon filing document adding patent(s), mail this copy to Director Copy 4—Case file copy



MARTIN & FERRARO, LLP
1557 LAKE O'PINES STREET, NE
HARTVILLE, OH 44632

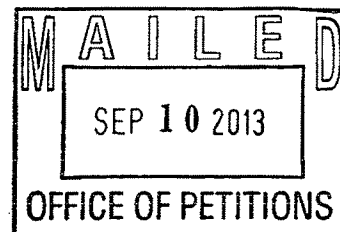

In re Patent No. 7,454,212
Issue Date: November 18, 2008
Application No. 11/199,586
Filed: August 8, 2005
Patentee(s): Xiaodong Li, et. al.

NOTICE

This is a Notice regarding the request for acceptance of a fee deficiency submission under 37 CFR 1.28(c) filed July 25, 2013.

The Office no longer investigates or rejects original or reissue applications under 37 CFR 1.56. 1098 Off. Gaz. Pat. Office 502 (January 3, 1989). Therefore, nothing in this Notice is intended to imply that an investigation was done.

Petitioner should note that 37 CFR 1.28(c) states in part: If status as a small entity is established in good faith, and fees as a small entity are paid in good faith, in any application or patent, and it is later discovered that such status as a small entity was established in error, or that through error the Office was not notified of a loss of entitlement to small entity status as required by § 1.27(g)(2), the error will be excused upon compliance with the separate submission and itemization. See 37 CFR 1.28(c)(2)(ii).

The itemization must include the following information:

- (A) Each particular type of fee that was erroneously paid as a small entity, (e.g., basic statutory filing fee, two-month extension of time fee) along with the current fee amount for a non-small entity;
- (B) The small entity fee actually paid, and when. This will permit the Office to differentiate, for example, between two one-month extension of time fees erroneously paid as a small entity but on different dates;
- (C) The deficiency owed amount (for each fee erroneously paid); and
- (D) The total deficiency payment owed, which is the sum or total of the individual deficiency owed amounts set forth in paragraph (c)(2)(ii)(C) of this section.

In the present request, applicant does not state the type of fee that was erroneously paid as a small entity. Therefore, the fee deficiency submission under 37 CFR 1.28(c) is **NOT ACCEPTED.**

Petitioner should submit the itemization within **TWO (2) MONTHS** from the mail date of this Notice. Failure to timely respond may result in the return of the fee deficiency paper, at the option of the Office.

Further correspondence with respect to this matter should be addressed as follows:

By Mail: Mail Stop PETITION
 Commissioner for Patents
 P. O. Box 1450
 Alexandria, VA 22313-1450

By FAX: (571) 273-8300
 ATTN: Office of Petitions

By Hand: U. S. Patent and Trademark Office
 Customer Service Window, Mail Stop Petitions
 Randolph Building
 401 Dulany Street
 Alexandria, VA 22314

Additionally, since the correspondence address of record differs from the address given in the present request, a courtesy copy of this decision is being mailed to the address in the request. Thereafter, all future communications from the Office will be mailed solely to the fee address of record unless otherwise instructed.

Inquiries related to this communication should be directed to the undersigned at (571) 272-3226.

/Andrea Smith/
Andrea Smith
Paralegal Specialist
Office of Petitions

cc: Amedeo F. Ferraro
 17383 Sunset Boulevard, Suite 250
 Los Angeles, CA 90272

IN THE UNITED STATES PATENT AND TRADEMARK OFFICE

In re Patent of:)	Confirmation No.: 1128
Xiaodong Li)	
Patent No.: 7,454,212)	(Serial No.: 11/199,586)
Issued: November 18, 2008)	(Filed: August 8, 2005)
For: OFDMA WITH ADAPTIVE)	
SUBCARRIER-CLUSTER)	
CONFIGURATION AND)	
SELECTIVE LOADING)	

Mail Stop M Correspondence
Commissioner for Patents
P.O. Box 1450
Alexandria, VA 22313-1450

Sir:

**RESPONSE TO NOTICE REGARDING REQUEST
FOR ACCEPTANCE OF FEE DEFICIENCY**

In response to the Notice issued September 10, 2013 with respect to the above-identified application, small entity status was established in good faith, although through error the Office was not notified of a loss of entitlement to small entity status. The present submission serves to correct this error. The itemization of the total amount of the deficiency is provided below:

<u>Fees Paid (Small Entity)</u>	<u>Date Paid</u>	<u>Large Entity Fee</u>	<u>Difference</u>
\$565 (4 th Yr. Maint. Fee)	5/17/12	\$1,600	\$1,035
Total Amount of Deficiency = \$1,035			

Applicant respectfully requests the Office to update the records to indicate the loss of small entity status and accept the fee deficiency in the total amount of \$1,035 which was previously charged to Deposit Account No. 50-1068 on August 1, 2013.

Please charge any additional fees required to enter this paper to our Deposit Account No. 50-1068.

Respectfully submitted,
MARTIN & FERRARO, LLP

Dated: September 16, 2013

By: /Amedeo F. Ferraro/
Amedeo F. Ferraro
Registration No. 37,129

17383 Sunset Boulevard, Suite 250
Los Angeles, California 90272
Telephone: (310) 286-9800
Facsimile: (310) 286-2795

Electronic Acknowledgement Receipt

EFS ID:	16866910
Application Number:	11199586
International Application Number:	
Confirmation Number:	1128
Title of Invention:	OFDMA WITH ADAPTIVE SUBCARRIER-CLUSTER CONFIGURATION AND SELECTIVE LOADING
First Named Inventor/Applicant Name:	Xiaodong Li
Customer Number:	22882
Filer:	Amedeo F. Ferraro/Adrienne Krauss
Filer Authorized By:	Amedeo F. Ferraro
Attorney Docket Number:	176.0003-01000
Receipt Date:	16-SEP-2013
Filing Date:	08-AUG-2005
Time Stamp:	17:38:50
Application Type:	Utility under 35 USC 111(a)

Payment information:

Submitted with Payment	no
------------------------	----

File Listing:

Document Number	Document Description	File Name	File Size(Bytes)/ Message Digest	Multi Part /.zip	Pages (if appl.)
1	Notification of loss of entitlement to small entity status	Response_to_Notice_Re_Req est_for_Acceptance_of_Fee_D eficiency.pdf	61822 <small>09133189101164246f1bcd531bc13a394d7 92435</small>	no	1

Warnings:

Information:

This Acknowledgement Receipt evidences receipt on the noted date by the USPTO of the indicated documents, characterized by the applicant, and including page counts, where applicable. It serves as evidence of receipt similar to a Post Card, as described in MPEP 503.

New Applications Under 35 U.S.C. 111

If a new application is being filed and the application includes the necessary components for a filing date (see 37 CFR 1.53(b)-(d) and MPEP 506), a Filing Receipt (37 CFR 1.54) will be issued in due course and the date shown on this Acknowledgement Receipt will establish the filing date of the application.

National Stage of an International Application under 35 U.S.C. 371

If a timely submission to enter the national stage of an international application is compliant with the conditions of 35 U.S.C. 371 and other applicable requirements a Form PCT/DO/EO/903 indicating acceptance of the application as a national stage submission under 35 U.S.C. 371 will be issued in addition to the Filing Receipt, in due course.

New International Application Filed with the USPTO as a Receiving Office

If a new international application is being filed and the international application includes the necessary components for an international filing date (see PCT Article 11 and MPEP 1810), a Notification of the International Application Number and of the International Filing Date (Form PCT/RO/105) will be issued in due course, subject to prescriptions concerning national security, and the date shown on this Acknowledgement Receipt will establish the international filing date of the application.

TO: Mail Stop 8 Director of the U.S. Patent & Trademark Office P.O. Box 1450 Alexandria, VA 22313-1450	REPORT ON THE FILING OR DETERMINATION OF AN ACTION REGARDING A PATENT OR TRADEMARK
---	--

In Compliance with 35 § 290 and/or 15 U.S.C. § 1116 you are hereby advised that a court action has been filed in the U.S. District Court Northern District of California on the following Patents or Trademarks:

DOCKET NO. CV 13-04468 LB	DATE FILED 9/26/13	U.S. DISTRICT COURT CLERK U.S. DISTRICT COURT 450 GOLDEN GATE AVE., BOX 36060 SAN FRANCISCO, CA 94102
PLAINTIFF ADAPTIX INC		DEFENDANT APPLE INC AND AT&T MOBILITY
PATENT OR TRADEMARK NO.	DATE OF PATENT OR TRADEMARK	HOLDER OF PATENT OR TRADEMARK
1 7,454,212		SEE COMPLAINT
2 6,947,748		
3		
4		
5		

In the above—entitled case, the following patent(s) have been included:

DATE INCLUDED	INCLUDED BY <input type="checkbox"/> Amendment <input type="checkbox"/> Answer <input type="checkbox"/> Cross Bill <input type="checkbox"/> Other Pleading		
PATENT OR TRADEMARK NO.	DATE OF PATENT OR TRADEMARK	HOLDER OF PATENT OR TRADEMARK	
1			
2			
3			
4			
5			

In the above—entitled case, the following decision has been rendered or judgement issued:

DECISION/JUDGEMENT

CLERK Richard W. Wiekling	(BY) DEPUTY CLERK Felicia Reloba	DATE October 2, 2013
------------------------------	-------------------------------------	-------------------------

1 Christopher D. Banys (CA Sate Bar: 230038)
Richard C. Lin (CA State Bar: 209233)
2 Daniel M. Shafer (CA State Bar: 244839)
cdb@banyspc.com
3 rcl@banyspc.com
dms@banyspc.com
4 BANYS, P.C.
1032 Elwell Court, Suite 100
5 Palo Alto, CA 94303
6 Telephone: (650) 308-8505
Facsimile: (650) 353-2202

7
8 Attorneys for Plaintiff,
ADAPTIX. INC.

9
10 **UNITED STATES DISTRICT COURT**
11 **NORTHERN DISTRICT OF CALIFORNIA**

12
13 ADAPTIX, INC.

14 Plaintiff,

15 v.

16 APPLE, INC., and AT&T MOBILITY
17 LLC

18 Defendants.

Case No. _____

**COMPLAINT FOR PATENT
INFRINGEMENT**

JURY TRIAL DEMANDED

19 **ORIGINAL COMPLAINT FOR PATENT INFRINGEMENT**

20
21 This is an action for patent infringement in which plaintiff, ADAPTIX, Inc. (“ADAPTIX”),
22 complains against defendants, Apple, Inc. (“Apple”) and AT&T Mobility LLC (“AT&T”)
23 (collectively “the Defendants”), as follows:

24 **THE PARTIES**

25 1. ADAPTIX is a Delaware corporation with its principal place of business at 4100
26 Midway Road, Suite 2010, Carrollton, Texas 75007.

27 2. On information and belief, Apple is a California corporation with a principal place of
28 business at 1 Infinite Loop, Cupertino, California 95014.

1 3. On information and belief, AT&T Mobility LLC (“AT&T”) is a Delaware corporation
2 with its principal place of business at 675 W. Peachtree St. Suite 42-090, Atlanta, Georgia 30375.

3 **JURISDICTION AND VENUE**

4 4. This action arises under the patent laws of the United States, Title 35 of the United
5 States Code. This Court has subject matter jurisdiction pursuant to 28 U.S.C. §§ 1331 and 1338(a).

6 5. Venue is proper in this judicial district pursuant to 28 U.S.C. §§ 1391(b)-(c) and
7 1400(b) because Defendants have committed acts within this judicial district giving rise to this action,
8 and continue to conduct business in this District, and/or have committed acts of patent infringement
9 within this District giving rise to this action.

10 6. On information and belief, each defendant is subject to this Court’s specific and/or
11 general personal jurisdiction pursuant to due process because they have committed acts giving rise to
12 this action within this judicial district and/or have established minimum contacts within California and
13 within this judicial district such that the exercise of jurisdiction over Defendants would not offend
14 traditional notions of fair play and substantial justice.

15 **BACKGROUND**

16
17 7. On March 9, 2012 ADAPTIX filed a patent infringement suit against APPLE, AT&T,
18 and AT&T, Inc. in the United States District Court for the Eastern District of Texas, Tyler Division,
19 Case No. 6:12-cv-0125 (“the first-filed case”).

20 8. The first-filed case alleged infringement by those defendants of U.S. Patent Nos.
21 7,454,212 and 6,947,748, the same two patents alleged against APPLE and AT&T in this Complaint,
22 as set forth in detail *infra*. (For convenience, these two patents may be referred to as “the Suit
23 Patents.”)

24 9. On information and belief, APPLE and AT&T were aware of each of the Suit Patents at
25 least as early as the March 9, 2012 filing date of the first-filed case.

26 10. On January 4, 2013, ADAPTIX filed a patent infringement suit against APPLE,
27 AT&T, and AT&T, Inc. in the United States District Court for the Eastern District of Texas, Tyler
28 Division, Case No. 6:13-cv-0028 (“the second-filed case”).

1 11. The second-filed case alleged infringement by those defendants of the Suit Patents, the
2 same two patents alleged against APPLE and AT&T in this Complaint, as set forth in detail *infra.*;

3 12. On information and belief, APPLE and AT&T were again made aware of each of the
4 Suit Patents at least as early as the January 4, 2013 filing date of the second-filed case.

5 13. On or about March 28, 2013, motions to transfer the first- and second-filed cases to this
6 District filed by APPLE and AT&T were granted. Eventually, the cases ended up in this Division and
7 were given Case Nos. 5:13-cv-1774 PSG and 5:13-cv-2023 PSG, respectfully, and assigned to the
8 Honorable Paul S. Grewal.

9 14. On or about September 20, 2013, an in-person and telephone hearing was held before
10 Judge Grewal in a case related to the first- and second-filed cases, i.e., Case No. 5:13-cv-1774,
11 concerning an ADAPTIX request for leave to supplement its Infringement Contentions in the
12 aforesaid -1774 Case (the "September 20th Hearing").

13 15. On information and belief, counsel-of-record for APPLE and AT&T, among others,
14 were either present at the September 20th Hearing or on the telephone during the Hearing.

15 16. Towards the end of the September 20th Hearing, ADAPTIX's counsel stated to the
16 Court, in words or effect, that ADAPTIX is in the process of supplementing its Infringement
17 Contentions in at least both the first- and second-filed cases to add as accused products APPLE's just-
18 newly-publicly-released-that-day products known as the Apple iPhone 5s and Apple iPhone 5c. At
19 the time of the filing of this Complaint, ADAPTIX had not yet received its September 25th electronic
20 Transcript Order request for the September 20th Hearing.

21 17. On September 26, 2013, ADAPTIX sent separate emails to APPLE and AT&T counsel
22 that stated the following: "As a follow-up to our concerns made apparent by our verbal comments
23 during last Friday's (September 20, 2013) hearing in front of Judge Grewal, Adaptix is in the process
24 of supplementing its Infringement Contentions to add the Apple iPhone 5s and Apple iPhone 5c. We
25 understand that these products were publicly released ... on or about September 20, 2013. Please
26 advise whether you will oppose Adaptix's supplementation, and if so, please provide a time you will
27 be available to meet and confer regarding the supplementation."
28

1 18. On information and belief, APPLE and AT&T were aware at least as early as
2 September 20, 2013 that ADAPTIX had formed a belief that the Apple iPhone 5s and Apple iPhone 5c
3 devices infringed one or more claims of the Suit Patents, and that ADAPTIX was seeking to
4 supplement its Infringement Contentions in at least both the first- and second-filed cases to add as
5 accused products APPLE's just-newly-publicly-released-that-day products known as the Apple iPhone
6 5s and Apple iPhone 5c.

7 **COUNT I**
8 **(INFRINGEMENT OF U.S. PATENT NO. 7,454,212)**

9 19. ADAPTIX is the owner by assignment of United States patent number 7,454,212,
10 entitled "OFDMA WITH ADAPTIVE SUBCARRIER-CLUSTER CONFIGURATION AND
11 SELECTIVE LOADING" ("the '212 Patent") with ownership of all substantial rights in the '212
12 Patent, including the right to exclude others and to sue and recover damages for the past and future
13 infringement thereof. A true and correct copy of the '212 Patent is attached as Exhibit A.

14 20. On information and belief, Apple is directly and/or indirectly infringing at least one or
15 more claims of the '212 Patent in this judicial district and elsewhere in California and the United
16 States by, among other things, making, using, offering for sale, selling and/or importing computerized
17 devices, including without limitation the iPhone 5s and iPhone 5c, which, at a minimum, directly
18 infringe the '212 Patent. Apple is thereby liable for infringement of the '212 Patent pursuant to 35
19 U.S.C. § 271. Apple's infringement has caused damage to ADAPTIX, which infringement by the
20 Defendants and damage to ADAPTIX will continue unless and until Apple is enjoined.

21 21. On information and belief, AT&T is directly and/or indirectly infringing at least one or
22 more claims of the '212 Patent in this judicial district and elsewhere in California and the United
23 States by, among other things, making, using, offering for sale, selling and/or importing computerized
24 devices, including without limitation the iPhone 5s and iPhone 5c which, at a minimum, directly
25 infringe the '212 Patent. AT&T is thereby liable for infringement of the '212 Patent pursuant to 35
26 U.S.C. § 271. AT&T's infringement has caused damage to ADAPTIX, which infringement and
27 damage will continue unless and until AT&T is enjoined.

1 U.S.C. § 271. AT&T's infringement has caused damage to ADAPTIX, which infringement and
2 damage will continue unless and until AT&T is enjoined.

3 27. Defendants directly contribute to and induce infringement through supplying infringing
4 systems and components to customers. Defendants' customers who purchase systems and components
5 thereof and operate such systems and components thereof in accordance with Defendants' instructions
6 directly infringe one or more claims of the '748 patent in violation of 35 U.S.C. § 271.

7 28. The infringement by each defendant identified in this Count has caused irreparable
8 injury to ADAPTIX for which remedies at law are inadequate. Considering the balance of the
9 hardships between the parties, a remedy in equity, such as a permanent injunction is warranted and
10 such a remedy would be in the public interest.

11 **PRAYER FOR RELIEF**

12 Wherefore, ADAPTIX respectfully requests that this Court enter:

- 13 A. Judgment in favor of ADAPTIX that each defendant has infringed the '212 and '748
- 14 patents as aforesaid;
- 15 B. A permanent injunction enjoining each defendant, its officers, directors, agents,
- 16 servants, affiliates, employees, divisions, branches, subsidiaries, parents and all others acting in active
- 17 concert or privity therewith from direct, indirect and/or joint infringement of the '212 and '748 patents
- 18 pursuant to 35 U.S.C. § 283;
- 19 C. Judgment and order requiring each defendant to pay ADAPTIX its damages with pre-
- 20 and post-judgment interest thereon pursuant to 35 U.S.C. § 284; and
- 21 D. Any and all further relief to which the Court may deem ADAPTIX entitled.

22 **DEMAND FOR JURY TRIAL**

23 ADAPTIX requests a trial by jury on all issues so triable by right pursuant to Fed. R. Civ. P.

24 38.

1 Date: September 26, 2013

ADAPTIX, INC.

2 By: /s/ Daniel M. Shafer

3 Christopher D. Banys (CA State Bar: 230038)

4 Richard C. Lin (CA State Bar: 209233)

5 Daniel M. Shafer (CA State Bar: 244839)

6 cdb@banyspc.com

7 rcl@banyspc.com

8 dms@banyspc.com

9 BANYS, P.C.

10 1032 Elwell Court, Suite 100

11 Palo Alto, CA 94303

12 Telephone: (650) 308-8505

13 Facsimile: (650) 353-2202

14 Paul J. Hayes

15 Steven E. Lipman

16 HAYES MESSINA GILMAN & HAYES, LLC

17 300 Brickstone Square, 9th Floor

18 Andover, MA 01810

19 phayes@hayesmessina.com

20 slipman@hayesmessina.com

21 Telephone: (978) 809-3850

22 Facsimile: (978) 809-3869

ATTORNEYS FOR THE PLAINTIFF

ADAPTIX, INC.

23
24
25
26
27
28

AO 120 (Rev. 08/10)

TO: Mail Stop 8 Director of the U.S. Patent and Trademark Office P.O. Box 1450 Alexandria, VA 22313-1450	REPORT ON THE FILING OR DETERMINATION OF AN ACTION REGARDING A PATENT OR TRADEMARK
---	---

In Compliance with 35 U.S.C. § 290 and/or 15 U.S.C. § 1116 you are hereby advised that a court action has been filed in the U.S. District Court Eastern District of Texas, Tyler Division on the following

Trademarks or Patents. (the patent action involves 35 U.S.C. § 292.):

DOCKET NO. 6:13-cv-853	DATE FILED 11/1/2013	U.S. DISTRICT COURT Eastern District of Texas, Tyler Division
PLAINTIFF ADAPTIX, Inc.		DEFENDANT Kyocera Corporation, Kyocera Communications, Inc., Kyocera International, Inc., Kyocera America, Inc. & Sprint Spectrum, L.P.
PATENT OR TRADEMARK NO.	DATE OF PATENT OR TRADEMARK	HOLDER OF PATENT OR TRADEMARK
1 7,454,212	11/18/2008	ADAPTIX, Inc.
2 6,947,748	9/20/2005	ADAPTIX, Inc.
3		
4		
5		

In the above—entitled case, the following patent(s)/ trademark(s) have been included:

DATE INCLUDED	INCLUDED BY	
	<input type="checkbox"/> Amendment <input type="checkbox"/> Answer <input type="checkbox"/> Cross Bill <input type="checkbox"/> Other Pleading	
PATENT OR TRADEMARK NO.	DATE OF PATENT OR TRADEMARK	HOLDER OF PATENT OR TRADEMARK
1		
2		
3		
4		
5		

In the above—entitled case, the following decision has been rendered or judgement issued:

DECISION/JUDGEMENT

CLERK	(BY) DEPUTY CLERK	DATE
-------	-------------------	------

Copy 1—Upon initiation of action, mail this copy to Director Copy 3—Upon termination of action, mail this copy to Director
 Copy 2—Upon filing document adding patent(s), mail this copy to Director Copy 4—Case file copy

AO 120 (Rev. 08/10)

TO: Mail Stop 8 Director of the U.S. Patent and Trademark Office P.O. Box 1450 Alexandria, VA 22313-1450	REPORT ON THE FILING OR DETERMINATION OF AN ACTION REGARDING A PATENT OR TRADEMARK
---	---

In Compliance with 35 U.S.C. § 290 and/or 15 U.S.C. § 1116 you are hereby advised that a court action has been filed in the U.S. District Court Eastern District of Texas, Tyler Division on the following

Trademarks or Patents. (the patent action involves 35 U.S.C. § 292.);

DOCKET NO. 6:13-cv-854	DATE FILED 11/1/2013	U.S. DISTRICT COURT Eastern District of Texas, Tyler Division
PLAINTIFF ADAPTIX, Inc.		DEFENDANT Kyocera Corporation, Kyocera Communications, Inc., Kyocera International, Inc., Kyocera America, Inc. & Cellco Partnership d/b/a Verizon Wireless
PATENT OR TRADEMARK NO.	DATE OF PATENT OR TRADEMARK	HOLDER OF PATENT OR TRADEMARK
1 7,454,212	11/18/2008	ADAPTIX, Inc.
2 6,947,748	9/20/2005	ADAPTIX, Inc.
3		
4		
5		

In the above—entitled case, the following patent(s)/ trademark(s) have been included:

DATE INCLUDED	INCLUDED BY <input type="checkbox"/> Amendment <input type="checkbox"/> Answer <input type="checkbox"/> Cross Bill <input type="checkbox"/> Other Pleading		
PATENT OR TRADEMARK NO.	DATE OF PATENT OR TRADEMARK	HOLDER OF PATENT OR TRADEMARK	
1			
2			
3			
4			
5			

In the above—entitled case, the following decision has been rendered or judgement issued:

DECISION/JUDGEMENT

CLERK	(BY) DEPUTY CLERK	DATE
-------	-------------------	------

Copy 1—Upon initiation of action, mail this copy to Director Copy 3—Upon termination of action, mail this copy to Director
 Copy 2—Upon filing document adding patent(s), mail this copy to Director Copy 4—Case file copy

AO 120 (Rev. 08/10)

TO: Mail Stop 8 Director of the U.S. Patent and Trademark Office P.O. Box 1450 Alexandria, VA 22313-1450	REPORT ON THE FILING OR DETERMINATION OF AN ACTION REGARDING A PATENT OR TRADEMARK
---	---

In Compliance with 35 U.S.C. § 290 and/or 15 U.S.C. § 1116 you are hereby advised that a court action has been filed in the U.S. District Court Eastern District of Texas, Tyler Division on the following

Trademarks or Patents. (the patent action involves 35 U.S.C. § 292.):

DOCKET NO. 6:13-cv-00778	DATE FILED 10/15/2013	U.S. DISTRICT COURT Eastern District of Texas, Tyler Division
PLAINTIFF ADAPTIX, Inc.		DEFENDANT Pantech Wireless, Inc., Pantech Co. LTD., AT&T, Inc. and AT&T Mobility LLC
PATENT OR TRADEMARK NO.	DATE OF PATENT OR TRADEMARK	HOLDER OF PATENT OR TRADEMARK
1 7,454,212	11/18/2008	ADAPTIX, Inc.
2 6,947,748	9/20/2005	ADAPTIX, Inc.
3		
4		
5		

In the above—entitled case, the following patent(s)/ trademark(s) have been included:

DATE INCLUDED	INCLUDED BY <input type="checkbox"/> Amendment <input type="checkbox"/> Answer <input type="checkbox"/> Cross Bill <input type="checkbox"/> Other Pleading		
PATENT OR TRADEMARK NO.	DATE OF PATENT OR TRADEMARK	HOLDER OF PATENT OR TRADEMARK	
1			
2			
3			
4			
5			

In the above—entitled case, the following decision has been rendered or judgement issued:

DECISION/JUDGEMENT

CLERK	(BY) DEPUTY CLERK	DATE
-------	-------------------	------

Copy 1—Upon initiation of action, mail this copy to Director Copy 3—Upon termination of action, mail this copy to Director
 Copy 2—Upon filing document adding patent(s), mail this copy to Director Copy 4—Case file copy

TO: Mail Stop 8 Director of the U.S. Patent and Trademark Office P.O. Box 1450 Alexandria, VA 22313-1450	REPORT ON THE FILING OR DETERMINATION OF AN ACTION REGARDING A PATENT OR TRADEMARK
---	---

In Compliance with 35 U.S.C. § 290 and/or 15 U.S.C. § 1116 you are hereby advised that a court action has been filed in the U.S. District Court Eastern District of Texas, Tyler Division on the following

Trademarks or Patents. (the patent action involves 35 U.S.C. § 292.):

DOCKET NO. 6:13-cv-922	DATE FILED 11/27/2013	U.S. DISTRICT COURT Eastern District of Texas, Tyler Division
PLAINTIFF ADAPTIX, Inc.		DEFENDANT NEC CASIO MOBILE COMMUNICATION LTD., NEC CORPORATION OF AMERICA, and CELLCO PARTNERSHIP (d/b/a) VERIZON WIRELESS
PATENT OR TRADEMARK NO.	DATE OF PATENT OR TRADEMARK	HOLDER OF PATENT OR TRADEMARK
1 7,454,212	11/18/2008	ADAPTIX, Inc.
2 6,947,748	9/20/2005	ADAPTIX, Inc.
3		
4		
5		

In the above—entitled case, the following patent(s)/ trademark(s) have been included:

DATE INCLUDED	INCLUDED BY <input type="checkbox"/> Amendment <input type="checkbox"/> Answer <input type="checkbox"/> Cross Bill <input type="checkbox"/> Other Pleading		
PATENT OR TRADEMARK NO.	DATE OF PATENT OR TRADEMARK	HOLDER OF PATENT OR TRADEMARK	
1			
2			
3			
4			
5			

In the above—entitled case, the following decision has been rendered or judgement issued:

DECISION/JUDGEMENT

CLERK	(BY) DEPUTY CLERK	DATE
-------	-------------------	------

Copy 1—Upon initiation of action, mail this copy to Director Copy 3—Upon termination of action, mail this copy to Director
 Copy 2—Upon filing document adding patent(s), mail this copy to Director Copy 4—Case file copy

AO 120 (Rev. 2/99)

TO: Mail Stop 8 Director of the U.S. Patent & Trademark Office P.O. Box 1450 Alexandria, VA 22313-1450	REPORT ON THE FILING OR DETERMINATION OF AN ACTION REGARDING A PATENT OR TRADEMARK
---	--

In Compliance with 35 § 290 and/or 15 U.S.C. § 1116 you are hereby advised that a court action has been filed in the U.S. District Court Northern District California on the Patents or Trademarks:

DOCKET NO. CV 14-02360 JCS	DATE FILED May 21, 2014	U.S. DISTRICT COURT 450 Golden Gate Avenue, 16 th Floor, San Francisco CA 94102
PLAINTIFF ADAPTIX INC		DEFENDANT HTC CORPORATION, ET AL
PATENT OR TRADEMARK NO.	DATE OF PATENT OR TRADEMARK	HOLDER OF PATENT OR TRADEMARK
17,754,212		***see Attach complaint***
26,947,748		
3		
4		
5		

In the above—entitled case, the following patent(s) have been included:

DATE INCLUDED	INCLUDED BY		
	<input type="checkbox"/> Amendment <input type="checkbox"/> Answer <input type="checkbox"/> Cross Bill <input type="checkbox"/> Other Pleading		
PATENT OR TRADEMARK NO.	DATE OF PATENT OR TRADEMARK	HOLDER OF PATENT OR TRADEMARK	
1			
2			
3			
4			
5			

In the above—entitled case, the following decision has been rendered or judgement issued:

DECISION/JUDGEMENT

CLERK Richard W. Wicking	(BY) DEPUTY CLERK Gina Augustine	DATE May 22, 2014
-----------------------------	-------------------------------------	----------------------

AO 120 (Rev. 2/99)

TO: Mail Stop 8 Director of the U.S. Patent & Trademark Office P.O. Box 1450 Alexandria, VA 22313-1450	REPORT ON THE FILING OR DETERMINATION OF AN ACTION REGARDING A PATENT OR TRADEMARK
---	--

In Compliance with 35 § 290 and/or 15 U.S.C. § 1116 you are hereby advised that a court action has been filed in the U.S. District Court Northern District of California on the following Patents or Trademarks:

DOCKET NO. CV 14-02359 KAW	DATE FILED May 21, 2014	U.S. DISTRICT COURT Northern District of California, 1301 Clay Street, RM 400S, Oakland, CA 94612
PLAINTIFF ADAPTIX INC		DEFENDANT HTC CORPORATION
PATENT OR TRADEMARK NO.	DATE OF PATENT OR TRADEMARK	HOLDER OF PATENT OR TRADEMARK
1 7,454,212		SEE ATTACHED COMPLAINT
2 6,947,748		
3		
4		
5		

In the above—entitled case, the following patent(s) have been included:

DATE INCLUDED	INCLUDED BY <input type="checkbox"/> Amendment <input type="checkbox"/> Answer <input type="checkbox"/> Cross Bill <input type="checkbox"/> Other Pleading		
PATENT OR TRADEMARK NO.	DATE OF PATENT OR TRADEMARK	HOLDER OF PATENT OR TRADEMARK	
1			
2		SEE ATTACHED COMPLAINT	
3			
4			
5			

In the above—entitled case, the following decision has been rendered or judgement issued:

DECISION/JUDGEMENT

CLERK Richard W. Wiekling	(BY) DEPUTY CLERK	DATE
----------------------------------	-------------------	------

Copy 1—Upon initiation of action, mail this copy to Commissioner Copy 3—Upon termination of action, mail this copy to Commissioner
 Copy 2—Upon filing document adding patent(s), mail this copy to Commissioner Copy 4—Case file copy

TO: Mail Stop 8 Director of the U.S. Patent & Trademark Office P.O. Box 1450 Alexandria, VA 22313-1450	REPORT ON THE FILING OR DETERMINATION OF AN ACTION REGARDING A PATENT OR TRADEMARK
--	--

In Compliance with 35 § 290 and/or 15 U.S.C. § 1116 you are hereby advised that a court action has been
 filed in the U.S. District Court Northern California on the following Patents or Trademarks:

DOCKET NO. CV 14-02894 MEJ	DATE FILED June 24, 2014	U.S. DISTRICT COURT 450 Golden Gate Avenue 16 th Floor, San Francisco, CA 94102
PLAINTIFF ADAPTIX INC.		DEFENDANT KYOCERA CORP ET AL
PATENT OR TRADEMARK NO.	DATE OF PATENT OR TRADEMARK	HOLDER OF PATENT OR TRADEMARK
1 7,454,212		
2 6,977,748		See Attached
3		
4		
5		

In the above—entitled case, the following patent(s) have been included:

DATE INCLUDED	INCLUDED BY <input type="checkbox"/> Amendment <input type="checkbox"/> Answer <input type="checkbox"/> Cross Bill <input type="checkbox"/> Other Pleading		
PATENT OR TRADEMARK NO.	DATE OF PATENT OR TRADEMARK	HOLDER OF PATENT OR TRADEMARK	
1			
2			
3			
4			
5			

In the above—entitled case, the following decision has been rendered or judgement issued:

DECISION/JUDGEMENT

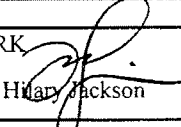
CLERK Richard W. Wicking	(BY) DEPUTY CLERK  Hilary Jackson	DATE June 26, 2014
-----------------------------	---	-----------------------

Copy 1—Upon initiation of action, mail this copy to Commissioner Copy 3—Upon termination of action, mail this copy to Commissioner
 Copy 2—Upon filing document adding patent(s), mail this copy to Commissioner Copy 4—Case file copy