

Handbook of
Laser Technology
and Applications

Volume III:
Applications

Edited by
COLIN VINE
JULIAN JONES



Handbook of Laser Technology and Applications

Volume III: Applications

Edited by

Colin E Webb

University of Oxford

and

Julian D C Jones

Heriot-Watt University

IoP

Institute of Physics Publishing
Bristol and Philadelphia

© IOP Publishing Ltd 2004

All rights reserved. No part of this publication may be reproduced, stored in a retrieval system or transmitted in any form or by any means, electronic, mechanical, photocopying, recording or otherwise, without the prior permission of the publisher. Multiple copying is permitted in accordance with the terms of licences issued by the Copyright Licensing Agency under the terms of its agreement with Universities UK (UUK).

The publisher has attempted to trace the copyright holders of all the figures reproduced in this publication and apologizes to them if permission to publish in this form has not been obtained.

British Library Cataloguing-in-Publication Data

A catalogue record for this book is available from the British Library.

ISBN 0 7503 0960 1 (Vol. I)
0 7503 0963 6 (Vol. II)
0 7503 0966 0 (Vol. III)
0 7503 0607 6 (3 Vol. set)

Library of Congress Cataloging-in-Publication Data are available



Development Editor: David Morris
Production Editor: Simon Laurenson
Production Control: Sarah Plenty
Cover Design: Victoria Le Billon
Marketing: Nicola Newey and Verity Cooke

Published by Institute of Physics Publishing, wholly owned by The Institute of Physics, London
Institute of Physics Publishing, Dirac House, Temple Back, Bristol BS1 6BE, UK
US Office: Institute of Physics Publishing, The Public Ledger Building, Suite 929, 150 South Independence
Mall West, Philadelphia, PA 19106, USA

Typeset in L^AT_EX 2_ε by Text 2 Text Limited, Torquay, Devon
Index by Indexing Specialists (UK) Ltd, Hove, East Sussex
Printed in the UK by MPG Books Ltd, Bodmin, Cornwall

VOLUME III: APPLICATIONS

PART D	APPLICATIONS: CASE STUDIES	1557
D1	Materials processing <i>Clive Ireland</i>	1559
D1.1	Welding <i>H Hügel and C Schinzel</i>	1561
D1.2	Cutting <i>John Powell and Claes Magnusson</i>	1587
D1.3	Laser marking <i>Terry J McKee</i>	1613
D1.4	Drilling <i>S Williams</i>	1633
D1.5	Photolithography <i>Shinji Okazaki</i>	1653
D1.6	Laser micromachining <i>Malcolm Gower</i>	1661
D1.7	Rapid manufacturing <i>Gary K Lewis</i>	1693
D1.8	Pulsed laser deposition of thin films <i>Ian Boyd and D B Chrisey</i>	1705
D2	Optical measurement techniques <i>Julian Jones</i>	1721
D2.1	Fundamental length metrology <i>J Flügge, F Riehle and H Kunzmann</i>	1723
D2.2	Laser velocimetry <i>C Tropea</i>	1749
D2.3	Laser vibrometers <i>Neil A Halliwell</i>	1779
D2.4	Electronic speckle pattern interferometry (ESPI) <i>Dave Towers and Clive Buckberry</i>	1805
D2.5	Optical fibre hydrophones <i>Geoffrey A Cranch and Philip J Nash</i>	1839
D2.6	Optical fibre Bragg grating sensors for strain measurement <i>David A Jackson and David J Webb</i>	1881
D2.7	High-speed imaging <i>Adam Whybrew</i>	1919
D2.8	Particle sizing <i>Nils Damaschke, Maurice Wedd, Adam Whybrew and Damien Blondel</i>	1931
D3	Medical <i>Terence A King and Brian C Wilson</i>	1951
D3.1	Light-tissue interactions <i>Steven Jacques and Michael Patterson</i>	1955
D3.2	Therapeutic applications: introduction <i>Reginald Birngruber</i>	1995
D3.2.1	Therapeutic applications: ophthalmology <i>Reginald Birngruber</i>	1999

D3.2.2	Therapeutic applications: refractive surgery <i>Giovanni Cennamo and Raimondo Forte</i>	2009
D3.2.3	Therapeutic applications: photodynamic therapy <i>Brian C Wilson and Stephen G Bown</i>	2019
D3.2.4	Therapeutic applications: thermal treatment of tumours <i>Stephen G Bown</i>	2037
D3.2.5	Therapeutic applications: dermatology—selective photothermolysis <i>Sean Lanigan</i>	2045
D3.2.6	Therapeutic applications: lasers in vascular surgery <i>Mahesh Pai</i>	2055
D3.2.7	Therapeutic applications: hardtissue/dentistry <i>Raimund Hibst</i>	2065
D3.2.8	Therapeutic applications: free-electron laser <i>E Duco Jansen, Michael Copeland, Glenn S Edwards, William Gabella, Karen Joos, Mark A Mackanos, Jin H Shen and Stephen R Uhlhorn</i>	2075
D3.3	Medical diagnostics <i>Brian C Wilson</i>	2087
D3.4	Laser applications in biology and biotechnology <i>Sebastian Wachsmann-Hogiu, Alexander J Annala and Daniel L Farkas</i>	2123
D3.5	Biomedical laser safety <i>Harry Moseley and Bill Davies</i>	2155
D4	Communications <i>John Marsh</i>	2181
D4.1	The basic point-to-point communications system <i>John Gowar</i>	2183
D4.2	High-capacity optical transmission systems <i>Paul Urquhart</i>	2231
D4.3	Local area networks <i>J Lehman and K L Johnson</i>	2289
D4.4	Fibre-to-the-chip: development of vertical cavity surface emitting laser arrays designed for integration with VLSI circuits <i>A V Krishnamoorthy, L M F Chirovsky, K W Goosen, J Lopata and W S Hobson</i>	2321
D4.5	Optical satellite communications <i>A Coello-Vera and M Maignan</i>	2345
D4.6	Smart pixel technologies and optical interconnects <i>Marc P Y Desmulliez and Brian S Wherrett</i>	2363
D5	Optical information storage <i>John Marsh</i>	2389
D5.1	Optical data storage <i>Tom D Milster</i>	2391
D5.2	Lasers in printing <i>Atsushi Kawamura, Seizo Suzuki and Yoshinori Hayashi</i>	2421
D6	Spectroscopy <i>Colin Webb</i>	2463
D6.1	Laser cooling and trapping <i>C S Adams and I G Hughes</i>	2465

D6.2	Ion trapping and laser applications to length and time metrology <i>P Gill and G P Barwood</i>	2485
D6.3	Time-resolved spectroscopy <i>Gavin D Reid and Klaas Wynne</i>	2507
D7	Earth and environmental sciences <i>Lance Thomas</i>	2529
D7.1	Satellite laser ranging <i>Roger Wood and Graham Appleby</i>	2531
D7.2	Lidar for atmospheric ozone remote sensing <i>G�rard Ancellet</i>	2563
D8	Lasers in astronomy <i>R C Powell</i>	2579
D8.1	Lasers in astronomy <i>Renaud Foy and Jean-Paul Pique</i>	2581
D9	Holography: holographic optical elements and computer-generated holography <i>Mohammad R Taghizadeh</i>	2625
D9.1	Holography: holographic optical elements—computer-generated holography—diffractive optics <i>Hans Peter Herzig</i>	2627
D10	High-intensity lasers for plasma studies <i>Colin Webb</i>	2643
D10.1	High-power lasers for plasma physics <i>M H R Hutchinson</i>	2645
D10.2	High-power lasers and the extreme conditions that they can produce <i>S J Rose</i>	2657
	Index	2665

D1.2 Cutting

John Powell and Claes Magnusson

D1.2.1 Introduction

Most laser cutting is carried out using CO₂ or Nd:YAG lasers. The general principles of cutting are similar for both types of laser although CO₂ lasers (see chapter B3.1) dominate the market. For this reason the following sections will concentrate on CO₂ laser cutting and compare this with Nd:YAG laser cutting in section D1.2.5. (however, readers interested solely in Nd:YAG laser cutting need to read the following sections first). Most of the following information is paraphrased from two books: *CO₂ Laser Cutting* by J Powell [1] and *Laser Institute of America Guide to Laser Cutting* by J Powell [2].

The basic mechanism of laser cutting is extremely simple and can be summarized as follows:

- (1) A high intensity beam of infrared light is generated by a laser.
- (2) This beam is focused onto the surface of the workpiece by means of a lens.
- (3) The focused beam heats the material and establishes a very localized melt (generally smaller than 0.5 mm diameter) throughout the depth of the sheet.
- (4) The molten material is ejected from the area by a pressurized gas jet acting coaxially with the laser beam as shown in figure D1.2.1. (*NB:* With certain materials this gas jet can accelerate the cutting process by doing chemical as well as physical work. For example, carbon or mild steels are generally cut in a jet of pure oxygen. The oxidation process initiated by the laser heating generates its own heat and this greatly adds to the efficiency of the process.)
- (5) This localized area of material removal is moved across the surface of the sheet thus generating a cut. Movement is achieved by manipulation of the focused laser spot (by CNC mirrors) or by mechanically moving the sheet on a CNC X–Y table. ‘Hybrid’ systems are also available where the material is moved in one axis and the laser spot moved in the other. Fully robotic systems are available for profiling three-dimensional shapes. Nd:YAG lasers can utilize optical fibres rather than mirrors (see section D1.2.5) but this option is not available for the longer wavelength CO₂ laser.

Before moving on to a more detailed description of the cutting process, now is a good time to summarize the benefits of laser cutting:

- The process cuts at high speed compared to other profiling methods. For example, a 1500 W CO₂ laser will cut 2 mm thick mild steel at 7.5 m min⁻¹. The same machine will cut 5 mm thick acrylic sheet at ~12 m min⁻¹.
- In most cases (e.g. the two previous examples) the cut components will be ready for service immediately after cutting without any subsequent cleaning operation.
- The cut width (kerf width) is extremely narrow (typically 0.1–1.0 mm). Very detailed work can be carried out without the restriction of a minimum internal radius imposed by milling machines and similar mechanical methods.

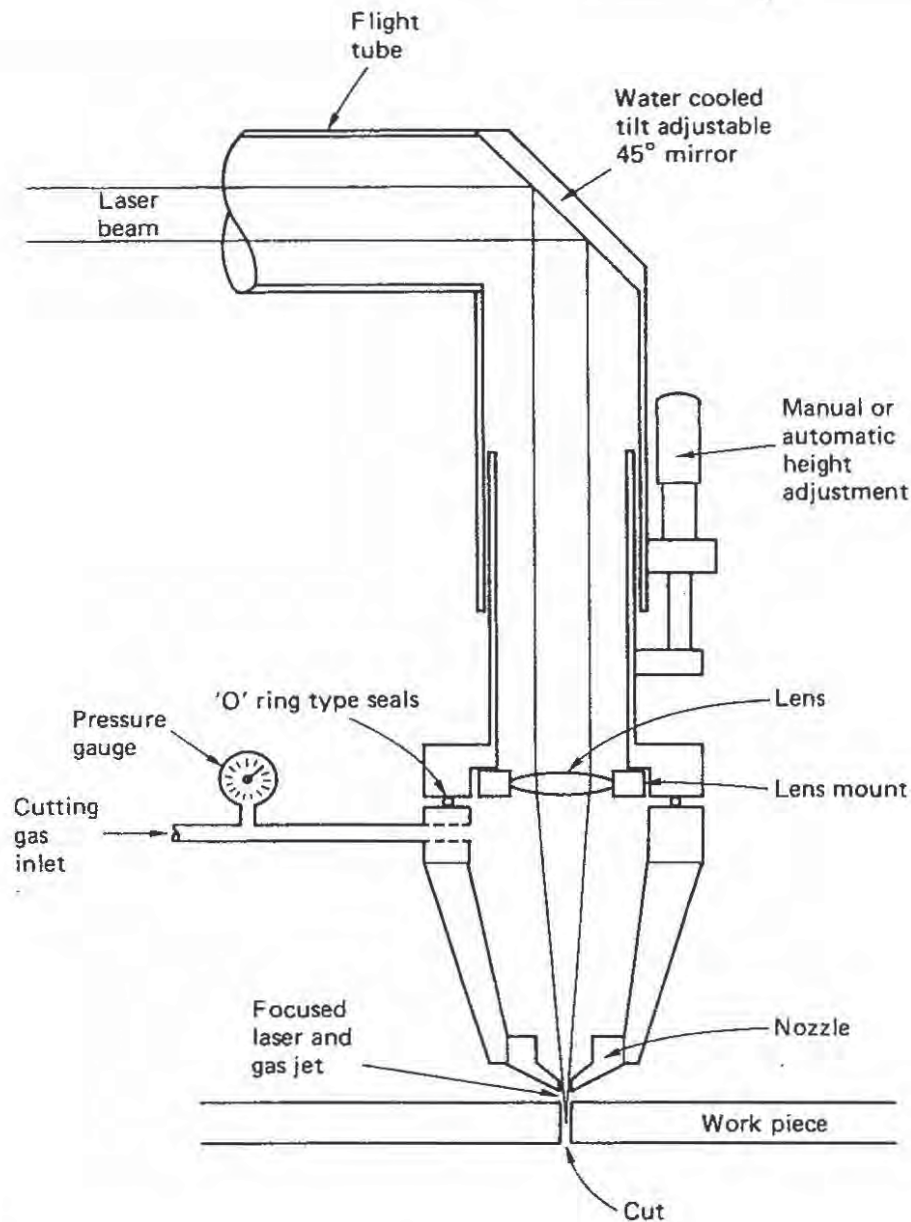

Figure D1.2.1. A schematic diagram of laser cutting. The lens mount or nozzle (or both) can be adjusted from left to right or into and out of the plane of the sketch. This allows for centralization of the focused beam with the nozzle. The vertical distance between the nozzle and lens can also be adjusted.

- The process can be fully CNC controlled. This, combined with the lack of necessity for complex jiggling arrangements, means that a change of job from cutting component 'A' out of steel to cutting component 'B' out of a polymer can be carried out in seconds. (*Note: Nd:YAG lasers cannot cut most plastics because they are transparent to Nd:YAG laser light—see section D1.2.5.*)
- Although laser cutting is a thermal process, the actual area heated by the laser is very small and most of this heated material is removed during cutting. Thus, the thermal input to the bulk of the material is very low, heat affected zones are minimized and thermal distortion is generally avoided.
- It is a non-contact process which means that material needs only to be lightly clamped or merely

positioned under the beam. Flexible or flimsy materials can be cut with great precision and do not distort during cutting as they would when cut by mechanical methods.

- Owing to the CNC nature of the process, the narrowness of the kerf width and the lack of mechanical force on the sheet being cut, components can be arranged to 'nest' very close together. Hence, material waste can be reduced to a minimum. In some cases this principle can be extended until there is no waste material at all between similar edges of adjacent components.
- Although the capital cost of a laser cutting machine is substantial, the running costs are generally low. Many industrial cases exist where a large installation has paid for itself in under a year.
- The process is extremely quiet compared to competing techniques, a factor which improves the working environment and the efficiency of the operating staff.
- Laser cutting machines are extremely safe to use in comparison with many of their mechanical counterparts.

D1.2.2 Cutting non-metals (CO₂ laser)

D1.2.2.1 General notes

There are three groups of non-metallic materials which are commonly cut by CO₂ lasers: polymers, wood-based products and ceramics. These will be discussed separately in the following sections. Although figure D1.2.2 is a good starting point for a description of laser cutting, it does not give a complete picture. Lasers are capable of cutting by mechanisms other than simple melting. In some cases (acrylic, polyacetal) the material is vaporized rather than melted in the cut zone and in others (epoxy resins, wood products) the material cannot melt and must be locally burnt away. These different cutting mechanisms affect the quality of the eventual cut edge in ways which are described later.

D1.2.2.2 Polymers

Polymers can be divided up into two main groups:

- (1) *Thermoplastics*: These are polymers that can be repeatedly melted down and cast into new shapes. They include polypropylene, polystyrene, polyethylene (polythene), polyamide (nylon) and others.
- (2) *Thermosets*: These materials cannot be remelted once they have been made into their initial shape. They sometimes involve the mixing of two liquids which then set hard. This group includes epoxy and phenolic resins, fibreglass, kevlar and most natural rubber products.

D1.2.2.2.1 Cutting thermoplastics

Figure D1.2.2 is a good description of how most thermoplastics are cut by a CO₂ laser. The laser produces a melt which is then blown out of the cut zone by a gas jet (usually air). This type of cutting is known as 'melt shearing' for obvious reasons (some workers also call it 'fusion cutting'). The resulting cut edge is of good quality but covered in microscopic ripples.

Not all the liquid is blown out of the cut zone and it is common to have a residue of resolidified melt or 'dross' on the lower edge of the cut. Thermoplastics can be cut at high speed and relatively thick sections can be profiled (See table D1.2.1).

There are two important thermoplastics that do not cut by the melt shearing mechanism:

- (1) Polyvinyl chloride (PVC): this material degrades chemically when heated by the laser. The fumes given off contain high levels of hydrogen chloride which is extremely corrosive and very toxic. For this reason *PVC must never be cut by laser unless suitable ventilation is arranged.*

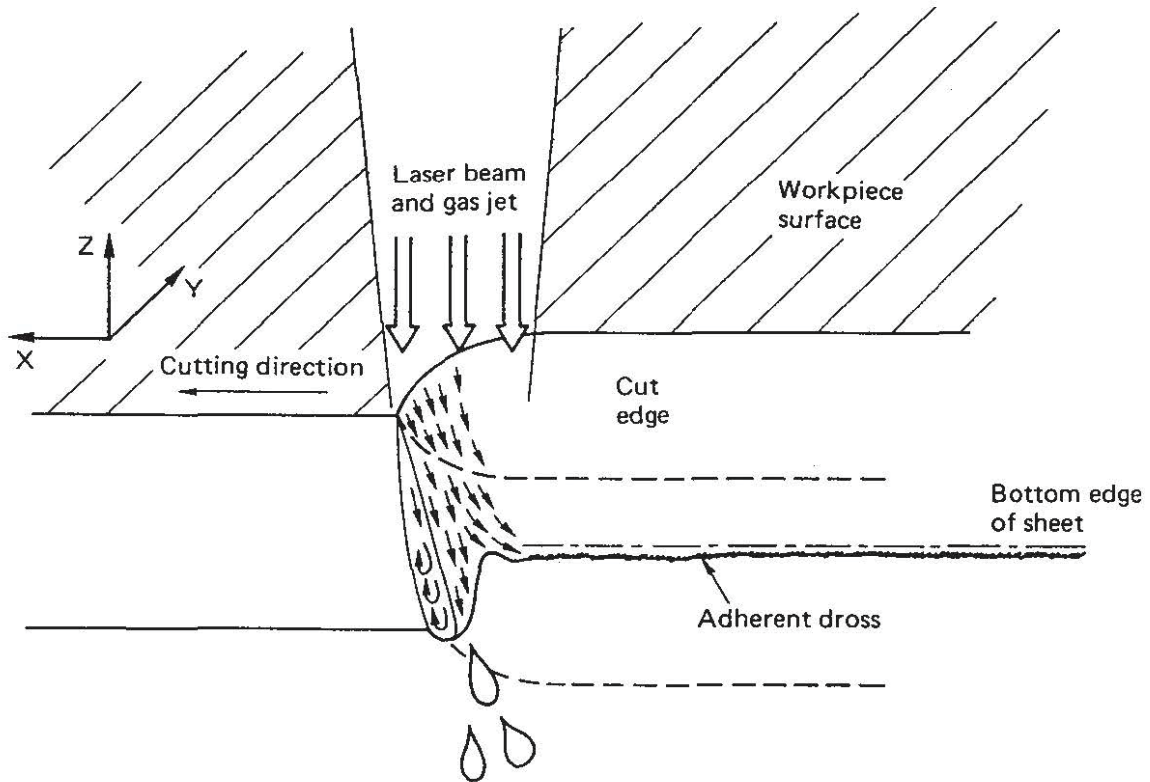

Figure D1.2.2. Laser cutting by melt shearing. The incident focused laser melts through the material and the gas jet acting with the laser removes the melt from the cut zone. Thermoplastics are cut in this way using air as the cutting gas jet. Metals are also cut by this mechanism if gases other than oxygen are used (e.g. argon for titanium or nitrogen for stainless steel).

- (2) Polymethyl methacrylate (acrylic, plexiglass etc): this material boils¹ rather than melts during the cutting process and, under the correct conditions can produce a polished cut edge. This process is known as cutting by vaporization. As the boiling vapour is blown away from the cut zone, it leaves a thin liquid layer on the cut edges. If the gas jet blowing the vapour away flows gently over this liquid layer, it will dry like paint to produce a glossy edged cut. If, however, the gas jet is above a minimum velocity, the solidifying liquid will become frosted.

D1.2.2.2.2 Cutting thermoset plastics

Thermoset plastics are not cut by the melt shearing mechanism shown in figure D1.2.2 for the simple reason that they cannot melt. In this case the laser burns the workpiece, reducing the plastic to a smoke made up of carbon and the other constituents of the original material. This process is known as cutting by chemical degradation. Because this process takes more energy than simple melting, cut speeds and maximum thicknesses for thermosets are lower than for thermoplastics (see table D1.2.2). The cut edge of such materials is generally flat, smooth and covered with a thin layer of carbon.

¹ To be accurate it should be mentioned that this is not really a boiling process. The laser heats up the solid polymer until it becomes a liquid which then depolymerizes giving off a vapour of the monomer (methyl methacrylate).

D1.2.2.3 Wood-based products

Wood and wood-based products are cut by a similar mechanism to thermoset plastics. The laser burns through the material to produce a cut and the carbon-based smoke is blown out of the cut zone by a gas jet, which is usually air. The top and bottom surfaces of the workpiece retain their original appearance but the cut edge is covered in a layer of carbon which darkens it. Low density woods such as pine cut faster than high density material such as teak (see table D1.2.3). The cut edge also becomes darker as the density is increased.

D1.2.2.4 Ceramics and glasses

D1.2.2.4.1 Ceramics

The ceramic of most interest to laser cutting is alumina which is used to produce micro-electronic substrates. This high-melting-point material cuts very slowly if full penetration cutting by the melt shearing (figure D1.2.2) method is employed (see table D1.2.4). Fortunately, most applications merely require cutting sheets of the material into rectangles and another faster technique called scribing can be used. Scribing involves the drilling of lines of small blind holes in the material surface using a single pulse of energy for each hole. The lines of holes are mechanically weak and can be used to accurately snap the workpiece into the rectangles required. Scribing speeds in excess of 20 m min⁻¹ are common, which is a factor of ten faster than full penetration cutting. Full penetration cutting is useful, however, if curves or circles need to be cut.

D1.2.2.4.2 Glasses

Most glasses have a high absorptivity to CO₂ laser light and can be cut by the melt shearing process (figure D1.2.2). However, the problem with these materials is that of cracking along the cut edge as a result of the rapid thermal cycle associated with laser cutting. Most glasses are not laser cut but quartz and heat-resistant glasses can be cut effectively. Scribing (see previous section) can also be used to produce lines for subsequent snapping.

D1.2.2.5 Other non-metals

The range of non-metals which can be cut by CO₂ laser is enormous. Cutting speeds exist in the literature for materials as diverse as boron epoxy composites and leather.

Trial and error is really the only way to investigate a new material but a literature search or contact with a laser supplier may help. It is necessary to be cautious of the fumes given off from any unknown material, particularly if it might contain PVC (see section D1.2.2.2).

One final note of interest: CO₂ laser cutting of foodstuffs is generally pointless. Good cut speeds and cut qualities may be achievable but the charred nature of the cut edge makes it taste unpleasant.

Table D1.2.1. Typical cutting speeds for thermoplastic polymers using a 500 W CO₂ laser [1]. *Notes:* (1) Cutting speeds can be changed dramatically by changes in molecular weight, degrees of crystallinity, and porosity. (2) As a first approximation, cutting speeds and maximum material thickness can be assumed to vary in a linear manner with laser power (between 100 and 1500 W). Maximum material thickness for 500 W = 15–30 mm depending on material type. (3) The cutting gas is usually air at moderate pressures (1–4 bar). Nozzle diameters are 1–2 mm. If a glossy edge is required on acrylic, gas pressures may be dropped to below 0.25 bar and nozzle diameters increased.

Thickness (mm)	Acrylic (PMMA) (m min ⁻¹)	Polyethylene (m min ⁻¹)	Polypropylene (m min ⁻¹)	Nylon (m min ⁻¹)	ABS (m min ⁻¹)	Polycarbonate (m min ⁻¹)
1	35.0	11.0	17.0	20.0	21.0	21.0
2	15.0	4.0	7.0	8.0	8.2	8.2
3	8.0	2.2	4.0	4.8	5.0	5.0
4	5.5	1.5	2.8	3.5	3.6	3.6
5	4.5	1.2	2.0	2.6	2.7	2.7
6	3.5	1.0	1.6	2.0	2.1	2.1
7	3.0	0.8	1.3	1.6	1.7	1.7
8	2.3	0.6	1.1	1.2	1.3	1.3
9	1.9	0.5	0.9	1.0	1.1	1.1
10	1.5	0.4	0.7	0.8	0.9	0.9
12	1.2	0.3	0.4	0.5	0.6	0.6

Table D1.2.2. Cutting speeds for selected thermoset plastics, rubbers and fibre-reinforced materials with a CO₂ laser [1]. *Notes:* (1) Cutting speeds for materials such as fibreglass depend on the relative proportion of glass, resin and trapped air in the material. (2) Cutting gas is usually high pressure air (3–10 bar), nozzle diameters 1–2 mm. (3) Cutting speeds will increase dramatically if porous grades of rubber are cut—figures given here are for fully dense material.

Material	Laser power (W)	Thickness (mm)	Cutting speed (m min ⁻¹)
Formica	400	1.6	7.8
	1200	1.6	14.0
Phenolic resin	400	3.0	2.8
	400	6.0	1.1
Rubber	400	3.0	4.0
	400	6.0	1.6
	400	9.0	0.9
Rubber (carbon filled, black)	400	3.0	3.0
	400	6.0	1.2
	400	9.0	0.7
	400	12.0	0.4
Fibreglass (glass fibre reinforced epoxy resin)	450	1.6	5.2
	1200	1.6	15.0
	400	3.2	2.4
Glass filled nylon	400	3.0	2.6

Table D1.2.3. Cutting results for wood and wood-based products using a CO₂ laser [1]. *Note:* Generally use high pressure air as assist gas (3–10 bar, nozzle diameter 1–2 mm).

Material	Laser power (W)	Thickness (mm)	Cutting speed (m min ⁻¹)
Poplar	500	10	5.0
Scotch Pine	500	10	3.3
Teak	500	10	3.5
Oak	500	10	2.9
Ebony	500	10	1.2
Pine	1000	6	8.0
Pine	1000	12	3.2
Pine	1000	20	1.6
Plywood	1000	6	7.0
Plywood	1000	12	3.0
Plywood	1000	20	1.5
MDF ^a	1000	6	9.0
MDF ^a	1000	12	4.0
MDF ^a	1000	20	2.0
Hardboard	500	3	10.0
Hardboard	500	4	7.0
Corrugated card	500	3	25.0
Paper	500	0.1	500.0+

Medium density fibreboard.

Table D1.2.4. Cutting data for full-penetration profiling of ceramic materials using a CO₂ laser [1].

Material	Laser power (W)	Thickness (mm)	Cutting speed (m min ⁻¹)
Glass	500	1	1.5
	500	2	1.0
	500	3	0.5
Alumina	500	1	1.4
	500	2	0.6
	1000	2	2.0
Silica	1200	1	0.6
Ceramic tile	1200	6.3	0.6

D1.2.3 Cutting mild and carbon steels

D1.2.3.1 General

In the previous section we have seen that CO₂ lasers can cut non-metallic materials by one of three mechanisms:

- (1) melt shearing (melting),
- (2) vaporization (boiling) and
- (3) chemical degradation (burning)

Some materials are cut by a combination of these mechanisms: for example, polycarbonate involves all three and a microscopically rippled, slightly charred cut edge is the result.

Mild and carbon steels are cut by a combination of melt shearing (see figure D1.2.2) and a chemical reaction with the cutting gas jet, which in this case is pure oxygen. The cutting mechanism is, for obvious reasons, known as oxidation cutting. Inside the cut zone the oxygen jet reacts with the iron in the steel to produce iron oxides. The reaction has two beneficial effects on the cutting process:

- (1) The chemical reaction produces heat which speeds up the cutting process. Typical cutting speeds are given in table D1.2.5.
- (2) chemical reaction produces an oxidized liquid with a lower melting point than steel, which does not adhere well to the solid steel and is easily blown away by the oxygen jet. This results in a dross-free cut edge and cut components which are ready for immediate use.

D1.2.3.2 Oxidation cutting

When cutting mild steel with oxygen, research has demonstrated that approximately half the energy supplied to the cut zone comes from the laser and the other half is produced by the chemical reaction [3]:

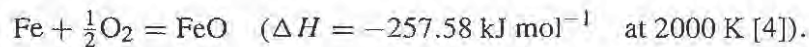

The oxidation cutting reaction produces regularly spaced striations on the cut edge even if the laser is used in its non-pulsed mode (i.e. cw or 'continuous wave'). An example of a typical mild steel cut edge is shown in figure D1.2.3 and these striations are clearly visible. Much research has been expended on the cyclic nature of the oxidation reaction which gives rise to these striations [5–8]), but no clear answer has emerged. The use of pulsed or modulated laser beams can reduce cut-edge roughness or the burning of small details. This replaces the naturally generated striation pattern with a finer one produced by the overlapping laser pulses.

Although the physics of striation generation is unclear the overall cutting mechanism is straightforward: the laser pre-heats the steel to a temperature at which iron burns spontaneously in an oxygen jet. The burning reaction is continuously extinguished by the surrounding cold metal and perpetuated by the encroachment of the moving laser beam.

In areas where a lot of detail is to be cut (e.g. when cutting saw teeth), the cutting of one area can overheat the next area to be cut. If this happens the burning reaction can possibly cover a larger area than usual and the shape of the final product can be affected as well as the cut-edge quality. Reducing the laser power or increasing the cut speed can minimize this problem.

D1.2.3.3 The importance of axial symmetry of the energy input to the cutting zone

It is clear that during the cutting of mild steel a delicately balanced dynamic equilibrium is established, rather than a steady state, where a continuous input of energy is matched by a continuous flow of material out of the cut zone. The striation-generation reactions take place in a circular manner around the centre line of the

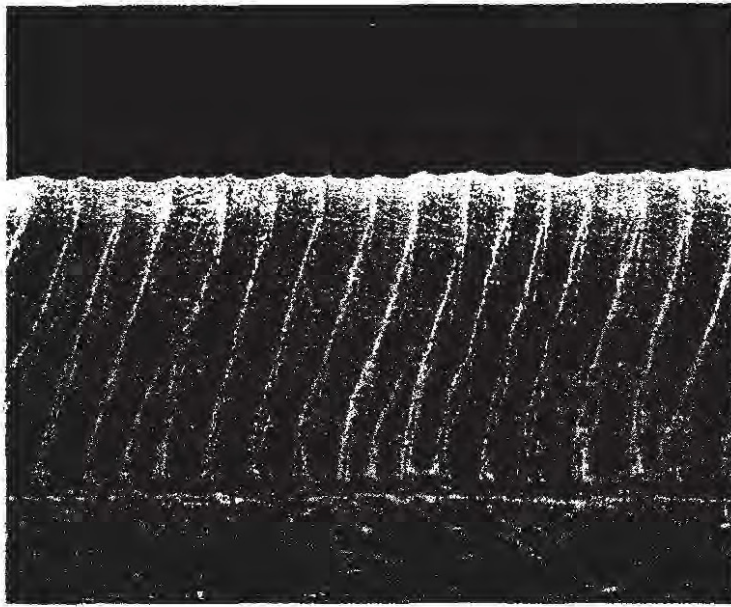

Figure D1.2.3. A typical mild steel cut edge which clearly shows the regularly spaced striations caused by the intrinsically cyclic oxidation reaction.

movement of the laser across the workpiece. It is therefore very important that the energy input to the area is axially symmetric (i.e. identical in cross section in all directions). The axial symmetry of the energy input can be affected in any of four ways:

- (1) The symmetry of the laser mode can be imperfect due to poor tuning or damaged optics.
- (2) Any linear polarization of the beam can be considered as asymmetry as the beam will cut better in certain directions than others (see section D1.2.4.2).
- (3) The symmetry of the oxygen jet can be disturbed by nozzle damage or contamination.
- (4) If the symmetry of the oxygen jet and the laser mode are individually very good, the symmetry of their combination can be upset if the two are not coaxial, due to incorrect centring of the nozzle with the beam.

Any lack of symmetry will result in inferior cutting in certain directions. Symptoms of this inferior cutting will take the form of increased cut edge roughness, adherent dross on the lower lip of the cut edge, material burning at corners and reduced cutting speeds.

D1.2.4 Cutting stainless steel and non-ferrous metals (CO₂ laser)

D1.2.4.1 General

Most metals can be laser cut although for any alloy there will be a limiting maximum thickness. For example, a high-power laser cutting machine of 3 or 4 kW power will commercially cut mild steel in thicknesses up to approximately 20 mm, stainless steel up to 15 mm, aluminium up to 8 mm and copper up to 6 mm. Relative cutting speeds for these different materials will decrease with maximum thickness (i.e. copper will cut slower than stainless steel etc).

The physical properties of materials which affect the laser cutting speed are:

- thermal conductivity,

Table D1.2.5. Approximate cutting speeds for mild and carbon steels. *Notes:* (1) Powers shown here and on other tables are measured at the workpiece. (2) When cutting the highest thickness for each power, cut-edge quality is reduced. (3). Results can be improved if the focal length of the lens is increased with material thickness (e.g. 63.5 mm (2.5 in) focal length up to 3 mm thick, 127 mm (5 in) from 3–8 mm, 190.5 mm (7.5 in) above 8 mm). (4) Many higher-power (e.g. 3 kW+) machines cut at lower speeds than expected at thinner sections (e.g. a commercially available 3.5 kW machine may only cut 1 mm thick mild steel at 9 m min⁻¹). This is because these machines are programmed to reduce their output power for thin sections in order to increase accuracy. At thicker sections full power is used and so, for example, the same 3.5 kW machine will cut 15 mm thick mild steel at 1.1 m min⁻¹.

Thickness (mm)	Cutting speed at 500 W (m min ⁻¹)	Cutting speed at 1000 W (m min ⁻¹)	Cutting speed at 1500 W (m min ⁻¹)	Oxygen pressure (bar)	Nozzle diameter (mm)
1	5.0	8.0	11.0	2–4	1.1–1.5
2	2.8	5.0	7.5	2–3	1.1–1.5
3	1.7	3.2	5.0	2–3	1.1–1.5
4	1.2	2.2	3.5	1.5–2.5	1.2–1.6
5	0.5	1.5	2.5	1.5–2.5	1.2–1.6
6	—	1.2	1.8	1–2	1.3–1.8
7	—	0.8	1.5	1–2	1.3–1.8
8	—	0.6	1.2	0.5–1.5	1.3–1.8
9	—	0.5	1.0	0.5–1.5	1.3–1.8
10	—	0.4	0.8	0.5–1.5	1.5–2.0
11	—	—	0.7	0.4–1.2	1.5–2.0
12	—	—	0.6	0.4–1.2	1.5–2.0
13	—	—	0.5	0.3–1.0	1.5–2.0
14	—	—	0.5	0.3–1.0	1.5–2.0
15	—	—	0.4	0.3–1.0	1.5–2.0

- reflectivity,
- melting point,
- density,
- specific heat and
- latent heat of fusion.

As any or all of these properties rise, the cutting speeds decrease as does the maximum thickness which can be cut.

The main process parameters which influence cutting speed are:

- laser power density and
- type of cutting gas.

Laser power density is obviously a function of the laser power and the focused spot diameter. If this density is low, cutting speeds will be low. As power is increased and/or the spot size decreased, the cutting speed will increase until an optimum is reached. If, however, the spot size is reduced down to a few tens of micrometres in diameter the cutting process may suffer because the kerf width will be too small to allow the passage of enough cutting gas. Sufficient gas must be allowed to travel through the cut zone to remove the melt. Also, if the power density is allowed to rise above an optimum range, the metal may boil rather than

melt. Boiling requires considerably more energy than melting and, in addition to this, the vapour generated absorbs the incoming laser beam. For this reason it is important to keep the power density of the laser high but below that level at which boiling becomes the preferred material response.

The type of cutting gas used basically falls into two categories: reactive and non-reactive (or inert). Metals generally experience exothermic oxidation reactions which can benefit cutting speeds. However, an oxidized cut edge is of inferior quality to a non-oxidized edge. In the early 1990s stainless steel was usually cut using oxygen because standard laser cutting machines had powers of between 1 and 2 kW and extra energy from the oxidation reactions was needed to increase cutting speeds. However, the melt generated when using oxygen for stainless steel had a high surface tension and this resulted in resolidified melt or dross on the bottom edge of the cut. Higher laser powers were available but these machines had poor quality modes which were not axially symmetrical (see section D1.2.3.3). Towards the end of the 1990s 3 and 4 kW machines of cutting mode quality became available. These machines could cut stainless steel quickly and at sections up to 12 mm thick using high-pressure nitrogen rather than oxygen. The resulting cuts were of higher quality and nitrogen cutting of stainless steel became the norm.

Most nickel alloys are also cut with nitrogen but many copper alloys have to be cut using oxygen because of the material's high reflectivity. An oxide layer is continuously created in and around the cut zone and this helps absorb the incident laser light.

Titanium alloys react uncontrollably when laser heated in an oxygen jet and, in any case, the mechanical properties are ruined by the presence of oxygen. The material even reacts with nitrogen and must therefore be cut in a stream of genuinely inert gas such as argon or helium.

D1.2.4.2 Polarization

CO₂ lasers generate a beam which is polarized and this can have a deleterious effect on the cutting process when cutting electrically conductive materials such as metals.

The symptom of cutting metals with a polarized beam is that the beam is deflected in different directions depending on the cutting direction. If such a beam is used to cut a 100 mm square in 10 mm thick metal, the top of the cut product may be correctly 100 mm × 100 mm but the bottom could be 99 mm × 101 mm.

For this reason laser cutting machines have a phase shifting mirror incorporated into them which delivers the beam to the workpiece in a random or circularly polarized condition. The cut front then remains perpendicular to the material surface at all times and the laser cuts equally well in all directions.

D1.2.4.3 Cutting speeds

Tables D1.2.5–D1.2.11 present a series of cutting speed results to be expected in a job shop environment, i.e. where a general-purpose laser cutting machine is expected to change materials and thicknesses regularly. Higher speeds can be achieved on machines dedicated to thin section slitting and profiling (e.g. 1 mm sheet aluminium; 40–50 m min⁻¹, 1 mm stainless steel; 30–40 m min⁻¹, 1 mm mild steel; 30 m min⁻¹, all at a laser power of 2.5 kW [12]). These high-speed, thin-sheet machines are starting to replace some of the traditional stamping methods employed by the automobile industry.

Table D1.2.6. Approximate cutting speeds for stainless steel cut with oxygen. *Notes:* (1) Cuts produced with oxygen are oxidized and dark grey in appearance. Some dross may be present on the bottom of the cut edge. (2) Nitrogen can be used instead of oxygen to produce a clear shiny cut edge. Cut speeds and maximum thickness will generally be lower than for oxygen cutting at the powers shown here. At higher powers (e.g. 3 kW), nitrogen can be faster than oxygen cutting.

Thickness (mm)	Cutting speed at 500 W (m min ⁻¹)	Cutting speed at 1000 W (m min ⁻¹)	Cutting speed at 1500 W (m min ⁻¹)	Oxygen pressure (bar)	Nozzle diameter (mm)
1	4.0	6.5	8.5	2-3	1.1-1.5
2	2.3	4.2	5.7	2-4	1.1-1.5
3	1.2	2.7	3.7	2-4	1.1-1.5
4	—	1.6	2.4	3-6	1.2-1.5
5	—	1.0	1.5	3-6	1.2-1.5
6	—	0.5	1.0	4-8	1.2-1.8
7	—	0.3	0.7	6-10	1.5-2.0
8	—	—	0.6	6-10	1.5-2.0
9	—	—	0.4	6-10	1.5-2.0

Table D1.2.7. Approximate cutting speeds for stainless steel cut with nitrogen at high laser power.

Thickness (mm)	Approximate maximum cutting speed at 3.5 kW (m min ⁻¹)	Nitrogen pressure (bar)	Nozzle diameter (mm)
1	10.0	12.0	1.5
2	6.6	13.0	1.7
3	4.1	14.0	2.0
4	3.0	14.0	2.0
6	1.8	14.0	2.5
8	1.2	14.0	2.5
10	0.8	14.0	3.0
12	0.4	14.0	3.0

Table D1.2.8. Approximate cutting speeds for titanium alloys at a laser power of 1000 W. *Notes:* (1) If the fatigue life and strength of titanium is important to the cut product argon or helium must be used as the cutting gas. The cut edge must be shiny silver in appearance, if it is discoloured (yellow, blue, etc) then it has become contaminated with oxygen or nitrogen. (2) Oxygen can be used to cut titanium at much higher speeds than air but the reaction is almost uncontrollable and the cut-edge quality is very poor. Fatigue life and strength are also badly affected.

Thickness (mm)	Cutting speed using	
	argon or helium (m min ⁻¹)	air (m min ⁻¹)
1.0	3.8	6.7
1.5	2.5	5.0
2.0	1.7	3.8
2.5	1.2	2.8
3.0	0.6	2.1
3.5	—	1.5
4.0	—	1.2

Table D1.2.9. Approximate cutting speeds for aluminium alloys using oxygen as the cutting gas. *Notes:* (1) Anodised aluminium cuts approximately 30% faster. (2) Different alloys cut at different speeds. (3) Piercing is more difficult than cutting. (4) Nitrogen can be used instead of oxygen. Cut quality improves but speeds are reduced by up to 50% at these powers. See table D1.2.10 for higher power nitrogen assisted cutting.

Thickness (mm)	Cutting speed	
	1000 W (m min ⁻¹)	1500 W (m min ⁻¹)
1.0	5.0	7.0
1.5	3.0	4.3
2.0	2.1	3.1
2.5	1.4	2.4
3.0	1.0	1.9
3.5	—	1.3
4.0	—	1.0

Table D1.2.10. Approximate cutting speeds for aluminium alloys cut with nitrogen at high laser power.

Thickness (mm)	Approximate maximum cutting speed at 3.5 kW (m min ⁻¹)	Nitrogen pressure (bar)	Nozzle diameter (mm)
1	10.0	10.0	1.5
2	7.0	10.0	1.7
3	4.0	10.0	2.0
4	3.0	10.0	2.0
5	2.0	10.0	2.0
6	1.0	10.0	2.5

Table D1.2.11. Laser oxygen cutting speeds for copper alloys. *Note:* Cutting speeds and laser piercing ability are highly dependent on surface condition and alloy content.

	Thickness (mm)	Laser power (W)	Cutting speed (m min ⁻¹)
Copper	1	1500	3.0
Copper	2	1500	1.0
Copper	1	1000	1.5
Brass	1	1500	5.0
Brass	2	1500	2.0
Brass	1	1000	3.0

D1.2.5 Nd:YAG laser cutting

D1.2.5.1 General

Far fewer Nd:YAG lasers are sold as cutting machines compared with CO₂ lasers. This is because, for general cutting applications, CO₂ lasers are most cost effective.

Nd:YAG lasers (see chapter B1.3) are preferred for the following purposes:

- if very fine detailed work is required in thin section material;
- if highly reflective materials such as copper or silver alloys are to be cut on a regular basis; *or*
- if an optical fibre is to be used to transport the laser beam to the workpiece.

Although both CO₂ and Nd:YAG lasers generate infrared light, the wavelength of the CO₂ laser light is ten times that of the Nd:YAG machines (10.6 and 1.06 μm respectively). Because the Nd:YAG laser light has a shorter wavelength, it has three advantages over CO₂ laser light:

- (1) Nd:YAG laser light can be focused down to a smaller spot than CO₂ laser light. This means that finer, more detailed work can be achieved (e.g. ornamental clock hands). This ability to be focused down to a very small spot is only possible at powers up to several hundred watts. Multi-kilowatt Nd:YAG lasers do not generally have the high beam quality necessary for fine focusing. The situation is worsened if optical fibres are employed and the power limit for fine focusing drops to below 100 W.

- (2) Nd:YAG laser light is less easily reflected by metal surfaces. For this reason Nd:YAG lasers are well suited for work on highly reflective materials.
- (3) Nd:YAG light can travel through glass (CO₂ light cannot). This means that high-quality glass lenses can be used to focus the beam down to a minimum spot size (see note earlier). Also, quartz optical fibres can be employed to carry the beam relatively long distances (hundreds of metres) to the workpiece.

The shorter wavelength light also has one major disadvantage:

- Most organic materials (e.g. plastics, wood-based products, leather, natural rubbers, etc) are transparent to Nd:YAG laser light. For this reason they cannot be cut by Nd:YAG lasers. If the laser power is low or the focused spot size is large, the light passes through the material without heating it enough to cut it. If the intensity of the laser beam is increased by increasing the power or reducing the spot size, the material will eventually respond with a localized explosion which may produce a tear or hole.

The situation with inorganic non-metals (ceramics, glasses, carbon, etc) is rather complex. Glass and quartz are not cut by Nd:YAG lasers because they are transparent at this wavelength. However, some inorganic materials can be cut very successfully. For example, industrial sapphire or diamond sheet can be cut into drill tips and cutting blades. Ceramic substrates for the electronics industry are also profiled in large quantities by Nd:YAG machines. The addition of carbon dust to rubber (to make tyres, etc) makes the material suitable for Nd:YAG laser cutting. Inorganic fillers (e.g. marble dust) are also added to plastics to colour or harden them. Once again this can make the material cut well. In these cases, however, the 'cutability' of the workpiece is heavily dependent on the type and amount of filler used. Adjustments to the mix can have catastrophic effects on the cutting process. (Plastic which has been dyed rather than filled may not cut at all.)

In summary, Nd:YAG lasers can be used to cut fine detail or they can be used with an optical fibre, in which case fine detail will not be possible (except when cutting foils or thin masks at low power). They are particularly suited to cutting high reflectivity alloys but cannot cut many non-metals.

D1.2.5.2 Cutting speeds and cut quality

Table D1.2.12 is a list of typical cutting speeds for Nd:YAG lasers. The list must be used only as a general guideline and, as usual with laser cutting, specific production trials will be needed to confirm the performance of a machine.

CO₂ lasers can be used close to their maximum power in either the cw or pulsed mode. For this reason a machine's cutting speeds are easy to identify. In the case of Nd:YAG lasers, the situation is not so straightforward. Nd:YAG machines can be used in the cw mode, but pulsing is more common (see chapters C2.1 and C2.2). The design of Nd:YAG lasers means that the pulse rates of these machines are much lower than for CO₂ lasers. CO₂ lasers can, for example, pulse at frequencies greater than 10 000 Hz. Nd:YAGs, in contrast, are usually limited to hundreds of Hz. This can be a limit on the cutting speed because the pulses must overlap on the workpiece to be able to cut through it. If the pulses do not overlap, the laser will generate a series of unconnected holes. For example, if the laser has a focused spot size of 0.3 mm and a maximum pulsing rate of 500 Hz then the maximum cutting speed of the machine will be less than $0.3 \times 500 \times 60 \text{ m min}^{-1}$ (9 m min^{-1}). The actual maximum cutting speed may be as low as half this value to ensure a good amount of overlap between pulses.

Cut edges produced by a pulsed laser will have parallel ripples on them which show where one pulse started and the next one finished. At lower speeds the pulses get closer together, the ripples become shallower and the cut edge becomes smoother.

If high-quality lenses are used without optical fibres, Nd:YAG lasers can cut finer detail than CO₂ machines. Cut widths smaller than 0.1 mm can be achieved. Cuts on this scale have a minimal amount of dross on the lower edge of the cut. Fine cutting of this type is generally restricted to low average-power pulses with a high level of pulse overlap. For this reason cutting speeds and workpiece thickness will generally be low.

Table D1.2.12. Typical cutting speeds for Nd:YAG lasers. Many of these speeds have been taken directly from manufacturers and should be taken only as a general guide. Best quality cuts may be obtained at lower speeds than those shown here.

Material	Thickness (mm)	Av. power (W)	Cutting speed (m min ⁻¹)	Gas
Mild steel	2.5	350	0.559	Oxygen
	5.0	350	0.127	Oxygen
	10.0	350	0.010	Oxygen
	10.0	500	0.10	Oxygen
	1.0	1000	4.5	Oxygen
	2.0	1000	2.5	Oxygen
	3.0	1000	1.5	Oxygen
	1.0	3000	20.0	Oxygen
	2.0	3000	11.0	Oxygen
	4.0	3000	5.0	Oxygen
	6.0	3000	2.0	Oxygen
	8.0	3000	1.0	Oxygen
	10.0	3000	0.8	Oxygen
	12.0	3000	0.5	Oxygen
Stainless steel	0.5	120	1.0	Oxygen
	2.0	120	0.45	Oxygen
	4.0	120	0.1	Oxygen
	1.0	400	0.9	Oxygen
	3.0	400	0.5	Oxygen
	5.0	400	0.25	Oxygen
	10.0	400	0.1	Oxygen
	1.0	500	3.0	Oxygen
	2.5	500	0.8	Oxygen
	10.0	500	0.16	Oxygen
	15.0	500	0.07	Oxygen
	2.0	3000	9.0	Oxygen
	4.0	3000	4.4	Oxygen
	6.0	3000	2.5	Oxygen
	8.0	3000	1.0	Oxygen
	10.0	3000	0.6	Oxygen
	2.0	3000	5.0	Nitrogen
	4.0	3000	2.8	Nitrogen
	6.0	3000	1.5	Nitrogen
8.0	3000	0.5	Nitrogen	
10.0	3000	0.2	Nitrogen	
Aluminium	1.0	120	0.5	Oxygen
	3.0	120	0.05	Oxygen
	2.0	500	0.75	Oxygen
	6.3	400	0.1	Oxygen
	2.0	3000	13.0	Oxygen
	3.0	3000	6.5	Oxygen
	4.0	3000	3.5	Oxygen

Table D1.2.12. (Continued.)

Material	Thickness (mm)	Av. power (W)	Cutting speed (m min^{-1})	Gas
	6.0	3000	1.5	Oxygen
	2.0	3000	7.0	Nitrogen
	3.0	3000	4.0	Nitrogen
	4.0	3000	1.8	Nitrogen
	6.0	3000	1.0	Nitrogen
Copper	1.0	120	0.5	Oxygen
	3.0	120	0.05	Oxygen
Titanium	1.0	120	1.0	Argon
	3.0	120	0.3	Argon
	4.0	400	0.25	Argon
Alumina (Al_2O_3)	2.0	100	0.18	Air
Silicon carbide	2.0	100	0.10	Air

D1.2.5.3 The use of optical fibres

Optical fibres can be used to transport Nd:YAG laser light to the workpiece as shown in figure D1.2.4 (see also chapter C4.3). Inside the focus module, the beam from the fibre is expanded before being re-focused onto the workpiece. The cutting head also includes a nozzle and pressurized gas system to remove melt from the cut zone. Optical fibre cutting systems of this type have a number of advantages and one main disadvantage:

D1.2.5.3.1 Advantages

- The laser can be situated metres (or hundreds of metres) from the workstation. This can be of great benefit in automobile production-line situations where space near the line is very limited.
- One laser can time share between a number of fibres and cutting heads. Although this is possible with mirror-controlled systems, it is much easier when using fibres.
- A number of cutting heads can work simultaneously in a confined area.
- Robots which control the movement of an optical fibre head are less specialized and vibration sensitive than multiple-mirror systems. This makes them cheaper and more reliable.

D1.2.5.3.2 Disadvantage

- Except at the lowest powers (less than 100 W), optical fibres corrupt the laser beam and reduce its ability to be focused to a very small spot. Focused spot sizes after an optical fibre are generally in the range 0.3–0.6 mm. At these larger spot sizes, cutting speeds are reduced and, more importantly, the machine cannot cut fine detail.

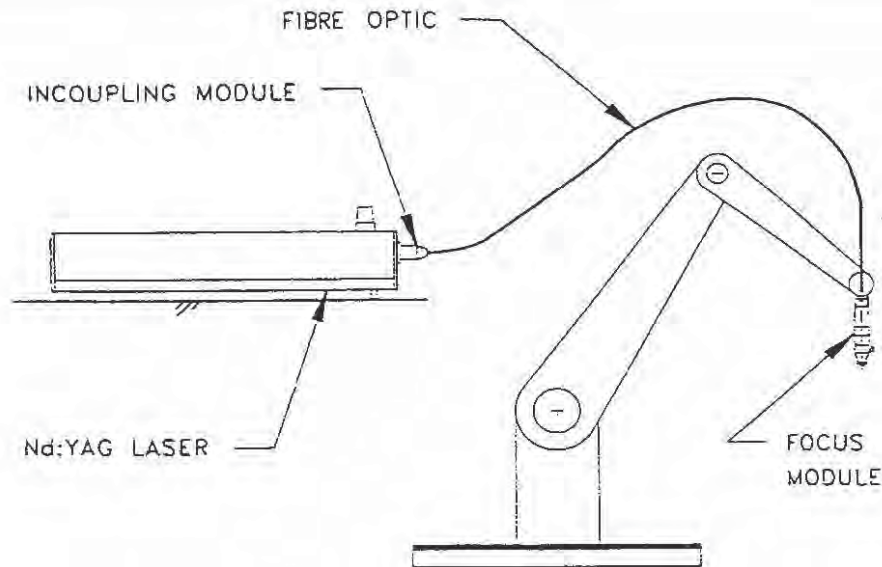

Figure D1.2.4. A schematic diagram of a robot-operated Nd:YAG laser cutting machine using an optical fibre to transport the laser beam to the cutting head [2].

D1.2.6 The energy balance in the cut zone and its relationship to the efficiency of the process

During laser cutting a dynamic equilibrium exists in the cut zone which balances the 'incoming' energy and material with the 'outgoing' energy and material.

Inputs to the cut zone are usually only

- (1) the laser energy and
- (2) the pressurized cutting gas jet (which may or may not be chemically reactive with the workpiece).

Outputs from the cut zone are more numerous and complex in nature:

- (1) Solid, liquid or gaseous material created in the cut zone and ejected to produce the cut.
- (2) The exhaust of the pressurized cutting gas jet (which may or may not have undergone chemical reaction with the workpiece, e.g. $\frac{1}{2}\text{O}_2 + \text{Fe} = \text{FeO}$ in the case of mild steel cutting).
- (3) Energy in the following forms:
 - conducted heat
 - reflected laser light
 - radiated light
 - convected heat
 - transmitted laser light (where 'transmitted' does not necessarily imply that the light has passed through the material being cut—a small proportion of light will pass directly through the cut zone without interacting with the cut front at all).

A simple energy balance for laser cutting can be expressed as

$$\text{Energy supplied to the cut zone} = \text{Energy used in generating a cut} \\ + \text{Energy losses from the cut zone (by conduction, radiation etc).}$$

The word 'losses' is used here to describe energy which does not contribute to the removal of material from the cut zone.

It has been shown by a simple theoretical analysis and experimental programme [9] that the proportion of energy lost from the cut zone decreases with increasing cutting speed. This means that the efficiency of the cutting process increases with increasing cutting speed, a phenomenon which has a profound effect on cutting speeds and on the maximum thickness of any material that can be cut by a particular laser.

The earlier energy balance can be expressed as a power balance as follows:

$$(P - b) \left[\frac{100 - r_f}{100} \right] = (E_{\text{cut}} vdk) + [(\pi 0.5dk)(A + B + C)] \quad (\text{D1.2.1})$$

considering a laser of power P cutting at a velocity v , where b is the laser power transmitted through the cut zone without interaction with the cut front; r_f is the reflectivity of the cut zone expressed as a percentage; E_{cut} is the specific energy needed to melt and remove one unit volume of material from the cut zone; d is the material thickness; k is the kerf width; A is the conductive loss function; B is the radiative loss function; and C is the convective loss function.

It will be noted that the reflective and transmitted losses from the cut zone are dealt with in the left-hand side of the equation, whereas the conductive, convective and radiative losses are included in the right-hand side. The logic behind this approach is the consideration that the losses from the cut zone can be divided into two types, primary and secondary.

Primary losses are those which leave the cut zone as they entered, as laser radiation. These include only transmitted and reflected laser light.

Secondary losses are those which leave the cut zone after thermal transformation of some kind. These include the conducted, convected and radiated losses. (The broad spectrum of radiated light may include a small proportion of $10.6 \mu\text{m}$ light but this did not originally emanate from the laser and it is, therefore, part of the secondary losses.)

The secondary losses are a function of the temperature of the cutting front and its surface area in contact with the surroundings. The cut-front geometry can be simplified to the shape shown in figure D1.2.5. The conductive losses come from the convex face in contact with the substrate and the convective and radiative losses come from the concave face exposed to the surrounding atmosphere. When cutting metals, convective and radiative losses are generally trivial but conductive losses are considerable.

Other points and simplified assumptions in equation (D1.2.1) which may need some clarification:

b (transmitted losses): During cutting it is often the case that the trailing edge of the cut front does not extend to the full diameter of the incident laser beam. A proportion of the available light therefore passes straight through the kerf without interacting with the cut front.

r_f : The reflectivity of the cut zone will be much less than the figures quoted for solid materials at ambient temperature. The cut zone has a higher absorptivity as a result of its high temperature, the presence of absorptive oxides, its shallow angle of incidence to the laser beam, its roughness and its absorptive layer of vapour.

E_{cut} : As a first approximation the specific energy of cutting can be assumed to be a constant for any given material. Similarly the average temperature (T_{av}) of the melt can be assumed to be constant for a given material. E_{cut} is simply the energy needed to heat a known volume of the material up to T_{av} .

vdk : The volume of material removed per unit time to generate a cut of width k in a material of thickness d at a cutting speed v . In the interests of simplification the kerf width is assumed to be a constant.

$0.5\pi dk$ (the surface area of the cutting zone; see figure D1.2.5): This is a great simplification as the cut zone is generally curved and inclined in nature. However, the shape described in figure D1.2.5 is a reasonable first approximation for our largely qualitative discussion.

A : In the interests of clarity, the conductive loss per unit area of cutting front will be assumed to be constant for a given material.

B and C : Assuming a set average temperature for the cutting front for a particular material, the convective

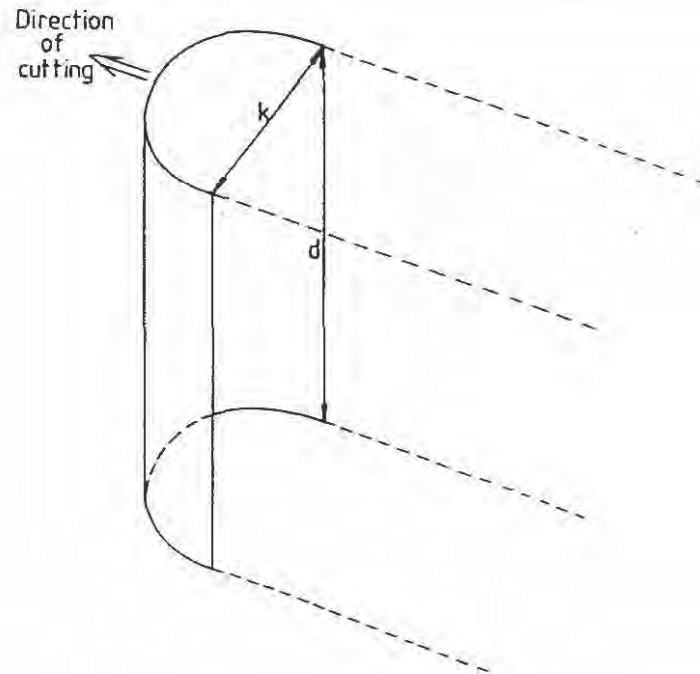

Figure D1.2.5. A schematic diagram of the simplified cut-front geometry.

and radiative losses per unit time can be assumed to be approximately proportional to the surface area of that front.

The most interesting feature of equation (D1.2.1) is that the energy used in cutting ($E_{\text{cut}}l dk$) is independent of the time taken to carry out the cut. The losses, however, are proportional to the time taken. From this point it is clear that the proportion of 'useful' to 'wasted' energy will change if the cutting speed is changed in order to cut material of a different thickness.

If the proportion of wasted energy is increased with decreasing cutting speed the process will become less efficient if the process has to be slowed to cut thicker material. To illustrate this point let us investigate what happens to equation (D1.2.1) if the cutting speed is changed as a result of decreasing the material thickness.

D1.2.6.1 The effect of decreasing the material thickness on cutting speeds

For the sake of discussion let us assume a possible doubling of the cutting speed when cutting material half the original thickness at the same laser power:

$$(P - b) \left[\frac{100 - r_f}{100} \right] = [E_{\text{cut}} 2v(0.5d)k] + [(0.5\pi d)(0.5k)(A + B + C)] \quad (\text{D1.2.2})$$

or

$$(P - b) \left[\frac{100 - r_f}{100} \right] = [E_{\text{cut}} vdk] + \left[\frac{(0.5\pi dk)(A + B + C)}{2} \right]. \quad (\text{D1.2.3})$$

From equation (D1.2.3) it is clear that the imbalance in the equation with respect to equation (D1.2.1) is that the losses by conduction, convection and radiation have been halved. This being the case the thermal input (left-hand) side of the equation has some energy to spare and the cutting speed can be further increased. This shows that the efficiency of the process increases with the cutting speed. As a result of this phenomenon, a workpiece of half thickness will be cut at more than twice the speed.

D1.2.6.2 The effect of laser power on cutting speed

Generally, an increase in laser power will result in an increased cutting speed. The relationship between power and speed is rather complicated and doubling the laser power may result in cutting speeds which are considerably smaller or greater than double. This is particularly true if different laser manufacturers are being compared. The complication in the comparison comes from two sources:

- In most cases a higher powered laser will not focus as well as a lower powered one. This means that the focused spot and the cut width will both be larger. The laser has to remove more material to produce a cut and this will slow it down.
- Laser cutting becomes more efficient as speeds increase. If two different power beams were focused to the same spot size then double the power would cut at more than double the speed. This is because there is less time for heat to escape by conduction from the cut zone when cutting at higher speed. Less heat is wasted in heating up the component and more energy is available for the cutting process.

D1.2.7 Aerodynamic aspects of laser cutting

Laser cutting generally involves the use of supersonic gas jets to remove material from the cut zone. The transition from subsonic to supersonic flow is determined by only two factors: the ratio of the supply pressure to the atmospheric pressure outside the nozzle and the number of atoms in the gas molecule. The transition will occur when

$$\frac{P_g + 1}{P_a} = (1 + n^{-1})^{1+0.5n} \quad (\text{D1.2.4})$$

where P_g is the nozzle supply pressure (bar; as measured on gauge); P_a is the ambient pressure (bar); and n is the number of degrees of freedom of the gas molecules.

n is determined by the number of atoms which make up the gas molecules as follows:

He, Ar (monatomic)	$n = 3$
air, O ₂ (diatomic)	$n = 5$
CO ₂ (polyatomic)	$n > 5$

Assuming an ambient atmospheric pressure of ~ 1 bar (100 kPa), oxygen or nitrogen will flow in a supersonic manner at supply pressures (P_g) above 0.89 bar. For argon or helium the pressure needs to be above 1.05 bar. Note that this value is independent of nozzle diameter.

At pressures above these thresholds the flow rate of a gas through a nozzle can be easily calculated from

$$V = 8.2d^2(P_g + 1) \text{ l min}^{-1} \quad (\text{D1.2.5})$$

where V is the flow rate (or gas consumption of the process), d is the nozzle diameter (mm) and P_g is the nozzle supply pressure (bar; measured on gauge).

At pressures just in excess of the threshold for supersonic flow a system of standing shockwaves will be established following the pattern shown in figure D1.2.6. At higher pressures this intersecting shock wave becomes curved and a Mach shock disc is formed as shown in figure D1.2.6(b). When a jet with these characteristics impinges on a workpiece, the slipstream and radially diverging flow can form a stable vortex ring on the surface as in figure D1.2.7 [10, 11]

A vortex ring of this sort can greatly reduce the vertical thrust of the gas jet in question and badly affect its ability to remove melt from the cut zone.

Another consequence of supersonic flow is a cyclic variation on downward thrust and pressure as the distance from the nozzle is increased, as shown in figure D1.2.8. As the supply pressure is increased or

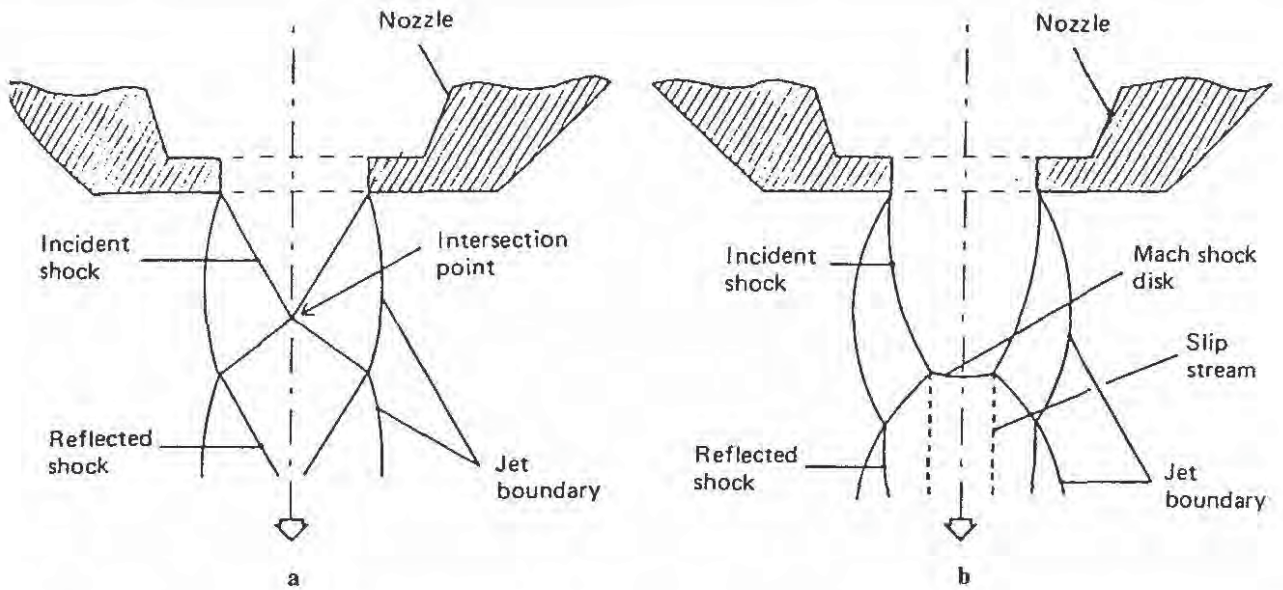

Figure D1.2.6. Shock structures in a supersonic jet: (a) regular intersection; (b) at higher pressures the formation of a Mach shock disc [10, 11].

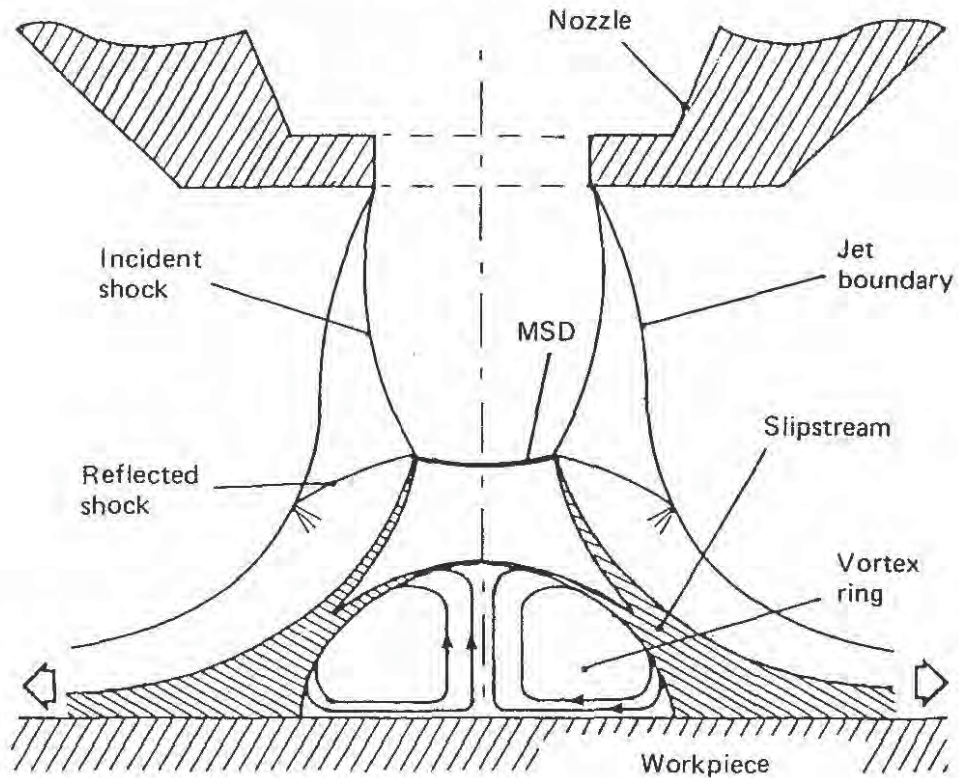

Figure D1.2.7. The formation of a vortex ring on the workpiece surface. This type of flow could interfere with the cutting process [10, 11].

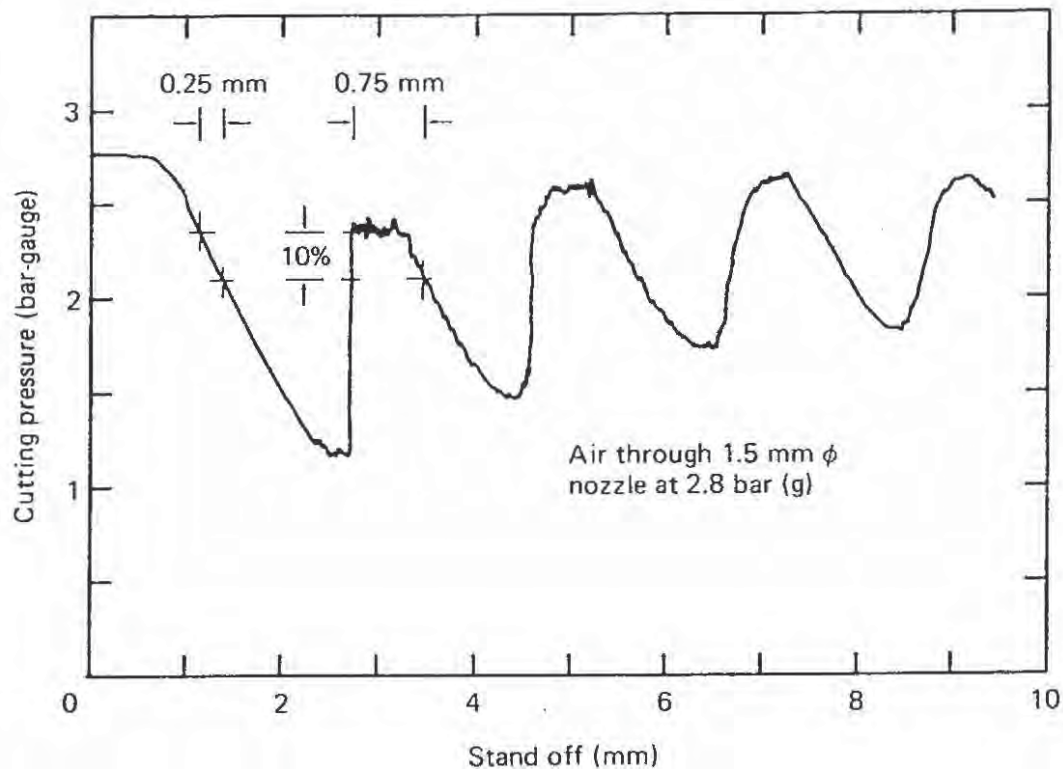

Figure D1.2.8. The variation in the pressure on the workpiece with distance from a typical cutting nozzle at constant supply pressure. The gas used was air at a supply pressure of 2.8 bar(g) through a 1.5 mm diameter circular nozzle [10, 11].

decreased this pattern of pressure spreads out or contracts. This can result in a reduction in gas thrust in the cut zone even if the supply pressure has been increased. A reduction in thrust of this type can reduce the possible cutting speed.

D1.2.8 Case study

It is misleading to choose a single component and then demonstrate why laser cutting is the preferred production method. In order to give a wider picture let us consider a *type* of component, i.e. a flat, approximately rectangular plate with ten holes, three slots and some edge detail. Let us also assume an overall size of 200 mm × 300 mm.

The route to the manufacture of the plate will be determined by a number of factors:

- material type and thickness,
- number of components required,
- accuracy required,
- edge quality required,
- and hole/slot sizes, etc.

The large number of production routes available include:

- laser cutting
- abrasive water jet cutting
- CNC mechanical machining

- plasma or flame cutting followed by machining,
- electric discharge machining,
- fixed tool punching,
- CNC punching, etc.

The decision will depend upon the costs associated with producing parts of the appropriate quality. The cheapest method will then be chosen. In many cases laser cutting will be the cheapest route but it is interesting to provide a few different examples of the product to demonstrate when an alternative method would be chosen.

(1) Material—3 mm thick steel: CO₂ laser cutting would be chosen except for the following conditions.

- If we require more than 100 000 components. For large batch production the initial costs associated with fixed tool punching would be justifiable.
- If the overall contour involved no complex profiles and only one or two pieces were required then plasma or flame cutting followed by machining might be a competitor.
- If the size tolerances on the holes or slots had to be much better than the ± 0.1 mm typical of commercial CO₂ laser cutting. In this case Nd:YAG laser cutting, CNC punching or electric discharge machining may be preferred.

(2) Material—15 mm thick metal: In this case CO₂ laser cutting would generally be chosen as the cheapest option if the metal in question was steel. However, commercial laser cutting cannot be used to profile aluminium or copper alloys at this thickness and the usual alternative would be abrasive water jet cutting.

(3) Material—5 mm titanium: CO₂ laser cutting would be employed in this case if the heat-affected zone created along the cut edge is not important to the finished product. In applications where fatigue life is critical the heat-affected zone would be problematic and so mechanical machining, abrasive water jet or electric discharge machining would be used.

(4) Material—10 mm polymer: In this case CO₂ laser cutting would be employed unless the number of components involved justified the use of injection moulding techniques.

References

- [1] Powell J 1998 *CO₂ Laser Cutting* 2nd edn (Berlin: Springer)
- [2] Powell J 1999 *LIA Guide to Laser Cutting* (Orlando, FL: Laser Institute of America)
- [3] Ivarson A, Powell J and Magnusson C 1992 Laser cutting of steels: Analysis of the particles ejected during cutting *Welding in the World* **30** 116–25
- [4] Barin I and Knacke O (Ed) *Thermochemical Properties of Inorganic Substances* (Berlin: Springer)
- [5] Arata Y, Maruo H, Miyamoto I and Takeuchi S 1979 Dynamic behaviour in laser gas cutting of mild steel *Trans. Japan. Welding Res. Inst.* **8** 15–26
- [6] Kaplan A F H, Wangler O and Schuocker D 1997 Laser cutting: fundamentals of the periodic striations and their on-line detection *J. Lasers Eng.* **6** 103–26
- [7] Ivarson A, Powell J, Kamalu J and Magnusson C 1994 The oxidation dynamics of laser cutting of mild steel and the generation of striations on the cut edge *J Mater. Process. Technol.* **40** 359–74
- [8] O'Neill, W and Steen W M 1994 A review of theoretical models of laser cutting *J. Lasers Eng.* **3** 281–99
- [9] Powell J, Ivarson A, Ohlsson L and Magnusson C 1993 Energy redistribution in laser cutting *Welding in the World* **31** 160–6
- [10] Ward B A 1984 Supersonic characteristics of nozzles used with lasers for cutting *Proc. Int. Conf. on the Application of Lasers and Electro-optics (ICALEO '84) (Boston, MA, 12–15 November)*
- [11] Fieret J, Terry M J and Ward B A 1987 *Overview of Flow Dynamics in Gas Assisted Laser Cutting (SPIE 801) (The Hague, 31 March to 3 April)* (Bellingham, WA: SPIE) pp 243–50
- [12] Petring D, Schneider F, Thelen C and Poprawe R 1999 Fast for sure: New developments in laser beam cutting of thin metal sheets (in German) *Laser Optoelectron.* **31** 70–5

Further reading

- Herziger G, Holtgen B, Treusch H G and Kreutz E W 1987 Photon-matter interactions: energy coupling in laser processing *Proc. LAMP '87 (Osaka)*
- Schulz W, Becker D, Franke J, Kemmerling R and Herziger G 1993 Heat conduction losses in laser cutting of metals *J. Phys. D: Appl. Phys.* **26** 1357-63
- Bernstein J B, Cohen S S and Wyatt P W 1992 Metal wire cutting by repeated application of low-power laser pulses *Rev. Sci. Instrum.* **63** 3516-18
- Vicanek M and Simon G 1987 Momentum and heat transfer of an inert gas jet to the melt in laser cutting *J. Phys. D: Appl. Phys.* **20** 1191-6
- Haferkamp H and Homburg A Cutting with high power Nd:YAG lasers and fibres for beam delivery *SPIE* **2207** 165-741 (NB: covers laser polarization effects for both CO₂ laser and Nd:YAG laser cutting)
- Geiger M 1993 Laser beam cutting with a system industrial robot—solid state laser (in German) *Laser Optoelectron.* **25** 69-76
- Dausinger E 1993 Beam-matter interaction in cutting with lasers of various wavelengths (in German) *Laser Optoelectron.* **25** 47-55
- Xie J, Kar A, Rothenflue J and Latham W P 1996 Comparative studies of metal cutting with high power lasers *Proc. GCL/HPL*
- Bunting K A and Cornfield G 1975 Towards a general theory of cutting: a relationship between the incident power density and the cut speed *Trans. ASME* 116-22