

Synthetic Quartz with High Ultraviolet Transmission

A. A. Ballman, D. M. Dodd, N. A. Kuebler, R. A. Laudise, D. L. Wood, and D. W. Rudd

Quartz has been synthesized under hydrothermal conditions at rates of 1.78 mm/day in the presence of LiNO_2 in Ag lined and Ag plated systems, and it is shown that such quartz has optical transmission between 1500 Å and 3 μ equal, and in some cases superior to, natural quartz. The uv cutoff at about 1500 Å has been shown to be associated with Fe whose concentration may be reduced by procedures that reduce the concentration of charge compensating H^+ in the lattice (growth in LiNO_2) and by procedures which reduce the concentration of Fe in solutions (inert conditions). Transmission near 3 μ is affected by OH which can be reduced by LiNO_2 .

Introduction

The optical absorption of synthetic quartz in the ir region has been studied considerably and it has been shown that OH is responsible for absorption in the 3- μ region.¹⁻³ Recently, the optical absorption has been shown to correlate with acoustic absorption⁴ and methods of hydrothermally growing quartz with low OH concentrations and high acoustic Q have been reported.^{5,6} It has been shown that quartz may be prepared from hydrothermal solutions in which the mineralizer is NaOH and the growth rate is greater than 1.78 mm/day with an OH concentration in the 15-30 ppm range and a Q as high as 1×10^6 , provided LiNO_2 is present in the growing solution.⁶ Mechanisms for the effect of LiNO_2 on OH concentration and Q have been proposed.⁷ Vitreous silica and crystalline quartz with good ir, visible, and uv transmission are of great technological interest, and the transmission of low OH synthetic crystalline quartz, particularly in the uv, has not been reported. Earlier experiments have shown that deliberate iron doping markedly reduces the transmission in the optical range.⁸⁻¹⁰ Large size inert (silver) systems capable of quartz growth in the absence of iron have recently become available.^{11,12} It now is possible, therefore, to investigate the properties of quartz grown in the absence of iron. We report here the results of a study of the optical transmission of quartz prepared under conditions known to exclude OH and of quartz prepared in the absence of Fe.

Experimental

The conditions and equipment used in this work were those ordinarily employed in commercial quartz synthesis in NaOH solutions^{13,14}: crystallization temperature—352°C; temperature difference (Δt) between crystallization and growth zones—44°C; degree of fill—82%; pressure—1570 atm; solution—1 M NaOH (0.1 M Li^+ salts where they were used); nutrient—fusing quality lascas—Brazilian crystalline quartz; seed orientation—basal plane, (0001); and rate—1.78 mm/day.

Growth was conducted under three sorts of conditions.

(1) Directly in a 4340 alloy steel autoclave. Such autoclaves have a protective layer of sodium iron silicate (acmite) that has been built up during previous runs, but the nutrient basket, baffle, seed frame, and seed holders are new low carbon steel in each run. In this paper, synthesis under these conditions is termed growth in an *iron autoclave*.

(2) Conditions as in (1) except that the nutrient basket, baffle, seed frame, and seed holders are plated with 0.25 mm of Ag. In this paper, synthesis under these conditions is termed *Ag plated*.

(3) Directly in a silver lined tube¹¹ of the sort shown in Fig. 1. This tube is essentially a scaled up version of Kolb's silver lined design.¹² The tube is supported by a steel shell that is more than capable of supporting the pressure differences between the water in the autoclave and the hydrothermal solution in the tube that take place during the run. The tube is closed with a Morey type¹³ closure and silver sheet seal that makes it much more convenient to use than the welded closure tubes¹⁵ previously used for inert high pressure hydrothermal conditions. The percent of fill of water *outside* the tube was 83% for the conditions of our experiments, and this fill provided a satisfactory pressure balance. The seed, frame, baffle, seed holders, and

The first five authors are with Bell Telephone Laboratories, Inc., Murray Hill, New Jersey 07974; D. W. Rudd is with Western Electric Company, Inc., Merrimack Valley Works, North Andover, Massachusetts.

Received 29 February 1968.

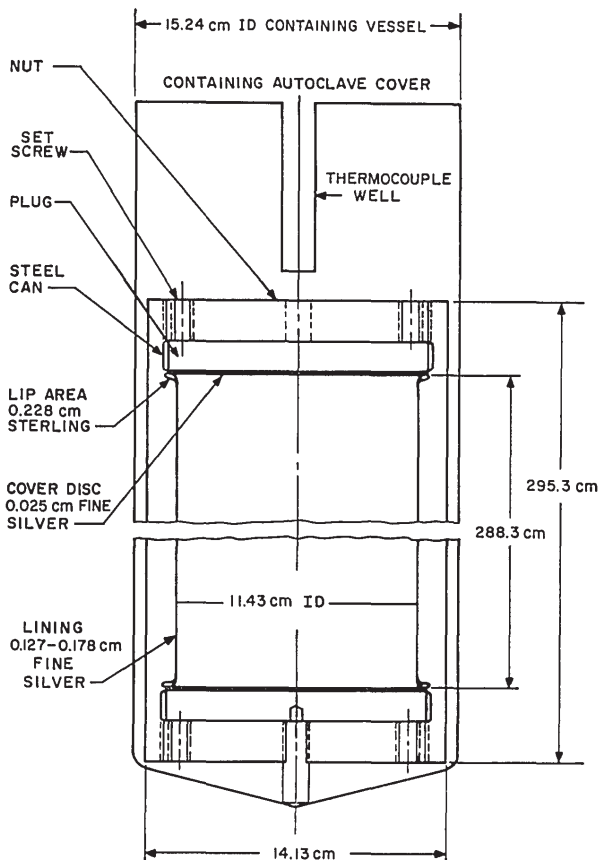

Fig. 1. Cross section of a silver lined tube for hydrothermal growth of quartz crystals.

nutrient basket in the silver tube runs were all made of silver. In this paper, synthesis under these conditions is termed *Ag tube*. Samples were cut parallel to the (0001) axis and in such a way that only (0001) growth was examined. Spectra were measured with unpolarized radiation on a Perkin-Elmer model 21 spectrophotometer in the $3\text{-}\mu$ region, on a Cary model 14 spectrophotometer between 2000 \AA and $2.5\text{ }\mu$, and on a MacPherson model 225 vacuum uv scanning monochromator below 2000 \AA .

Results and Discussion

Figures 2 and 3 show the absorption spectra of the samples prepared in this study. In Fig. 2, the near and far uv are shown on two different ordinate scales to accommodate the greatly increased absorption in the far uv. Figure 3 shows the ir absorption in the $3\text{-}\mu$ region where the absorption is due to OH stretching vibrations. Table I identifies the crystals studied and lists them in increasing order of uv absorption as measured by their uv cutoff wavelength defined as the wavelength at which the extinction coefficient $\alpha = (1/t) \log_{10} (I_0/I) = 1.5\text{ cm}^{-1}$. As can be seen from Table 1, the sample order as determined by cutoff wavelength is similar to that determined by OH concentration. The OH concentration was calculated by converting the extinction coefficient at 3500 cm^{-1} to

ppm OH by weight assuming the relationship $\text{ppm} = 100\alpha$, which has previously been used for crystalline quartz.¹⁶

Examination of Table I shows that the best quality with respect to both uv and ir transmission is obtained when OH (addition of LiNO_2) and Fe are excluded (crystallization in Ag tube). A sample prepared in this manner (X-246) is slightly more transparent in the uv than natural quartz and equivalent to natural quartz in the ir. Transmission results are nearly as good with only a slight reduction in the ir transmission when LiNO_2 is present and Fe is partly excluded (Ag plated conditions, X-261). Somewhat poorer quartz results, as judged by the uv transmission, when no attempt to exclude Fe is made even though LiNO_2 is present (X-162), and a further decrease in transmission both in the ir and uv occurs when Li_2CO_3 is used (1802-8) even though iron is partially excluded. Even poorer transmission occurs when no attempt to exclude either iron or OH is made (X-1). KOH is shown to be much inferior to NaOH as a mineralizer since in its presence (X257-23) both the ir and uv transmission are poor. There seems to be no particular advantage in using nutrient prepared from high purity SiCl_4 instead of melting lascar, as sample (H-2) shows.

Fe might be included in SiO_2 either substitutionally or interstitially. Both Fe^{2+} and Fe^{3+} have been observed in quartz and are thought to be responsible for the colors of citrine and amethyst.^{8-10,17-19} Since the ionic radius of Fe^{2+} (0.75 \AA) is a poor fit to the Si^{4+} (0.42 \AA) site, it probably occurs interstitially while Fe^{3+} (0.64 \AA) may occur either substitutionally or interstitially. Thus, interstitial Fe^{3+} may charge compensate substitutional Fe^{3+} (Ref. 18) at least when the iron concentration is appreciable.

However, the iron concentration in the crystals examined in this study is probably too low for Fe self-compensation to be important. Indeed the uv absorption which we have observed in the crystals of this study is at much shorter wavelengths ($<2400\text{ \AA}$) than that seen in the studies of green quartz, citrine, and amethyst ($>3400\text{ \AA}$). Thus, we believe that at the low concentrations of Fe present in this study the important charge compensating species for substitutional Fe^{3+} is OH with the positive charge being provided by H^+ in the lattice and the O being the normal lattice oxygen.

Consequently, growth conditions which reduce OH in the lattice (Li^+ salts and particularly LiNO_2) will reduce Fe^{3+} since its distribution constant will depend upon the ease with which it can be charge compensated. In addition, growth conditions which reduce the iron concentration in solution (Ag tube, Ag plating) will also reduce Fe^{3+} in the lattice. Similarly, OH may be reduced by procedures that reduce the Fe concentration in the system but since other ions such as Al^{3+} (from the nutrient) may charge compensate for H^+ , this effect is partially obscured.

Referring to Fig. 2, it appears that there are at least three absorption components in the uv: one near 2400 \AA , one near 1950 \AA , and one near 1600 \AA . The one

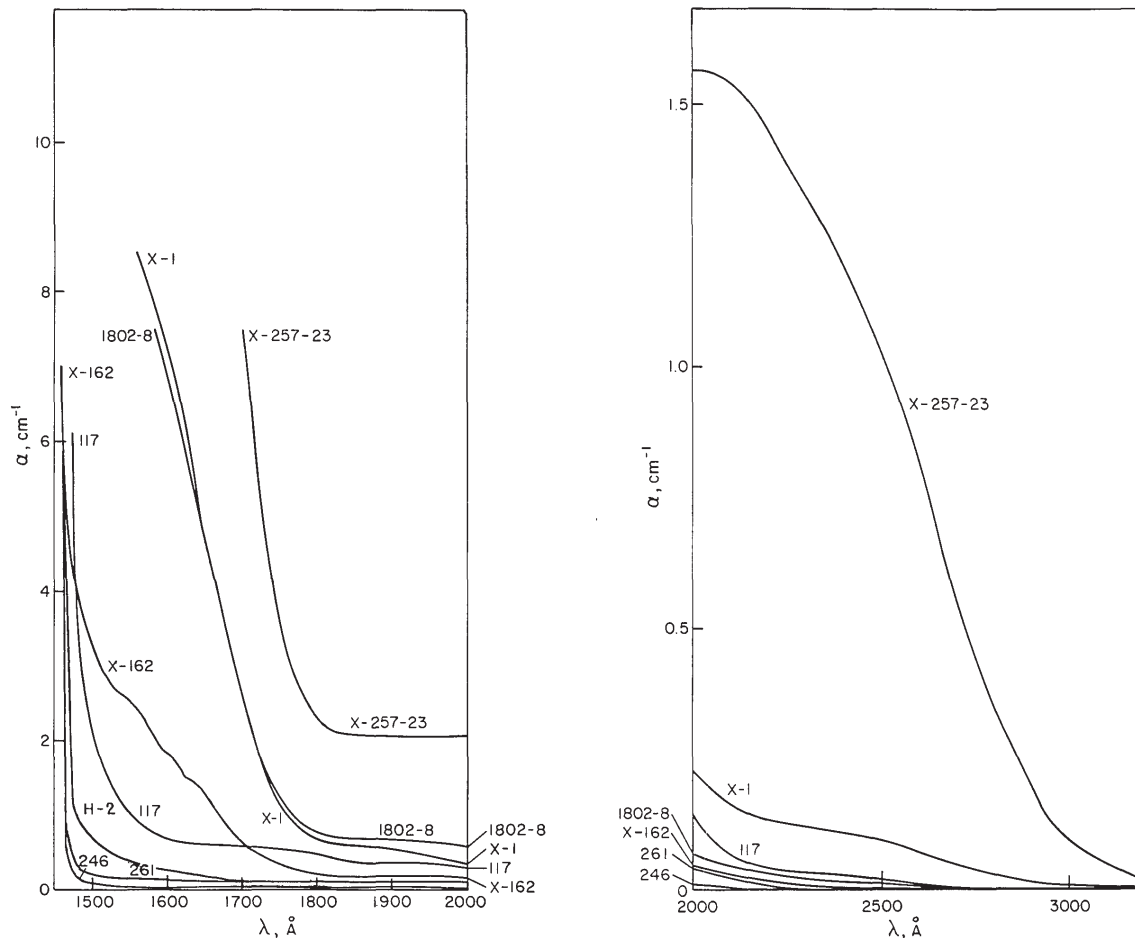

Fig. 2. Ultraviolet spectra of synthetic and natural quartz grown under various conditions. $\alpha = (1/t) \log_{10} (I_0/I)$ is the extinction coefficient per cm of sample thickness. Sample descriptions are in Table I.

Table I. Properties of Synthetic Quartz Crystals

Crystal designation	Cutoff at $\alpha = 1.5$ (cm^{-1} , \AA)	OH (ppm)	Growth conditions	
X-246	1460	4	Ag tube	NaOH + LiNO ₂
X-261	1465	17	Ag plated	NaOH + LiNO ₂
H-2	1480	4	Ag tube (SiCl ₄ nutrient)	NaOH + LiNO ₂
Natural #117	1520	4	—	—
X-162	1630	14	Fe autoclave	NaOH + LiNO ₂
1802-8	1740	30	Ag plated	NaOH + Li ₂ CO ₃
X-1	1740	41	Fe autoclave	NaOH
X257-23	2200	220	Ag tube	KOH

near 2400 \AA has definitely been associated with Fe³⁺ in vitreous SiO₂ (Ref. 20), although not all absorption bands at 2400 \AA are due to Fe³⁺ (Ref. 21). It is probable that the other two are also associated with this ion and that the uv absorption in our samples is due to Fe. From the correlation of OH concentration with uv cutoff observed in Table I, it is evident that Fe concentration is linked to H⁺ charge compensation. Furthermore, from the correlation of uv cutoff with the inertness of growth conditions, it is evident that Fe

concentration in the grown crystals is correlated with Fe concentration in the growth solution. The especially poor uv transmission in X-257-23, even though it was grown under inert conditions, suggests that the high OH content associated with KOH growth may have been due to particulate inclusions^{1,4} of H₂O that cause scattering and decrease the uv transmission.

Since the lascal nutrient contains some Al³⁺, it is possible that some uv absorption is due to this ion and further improvements in transmission might be ex-

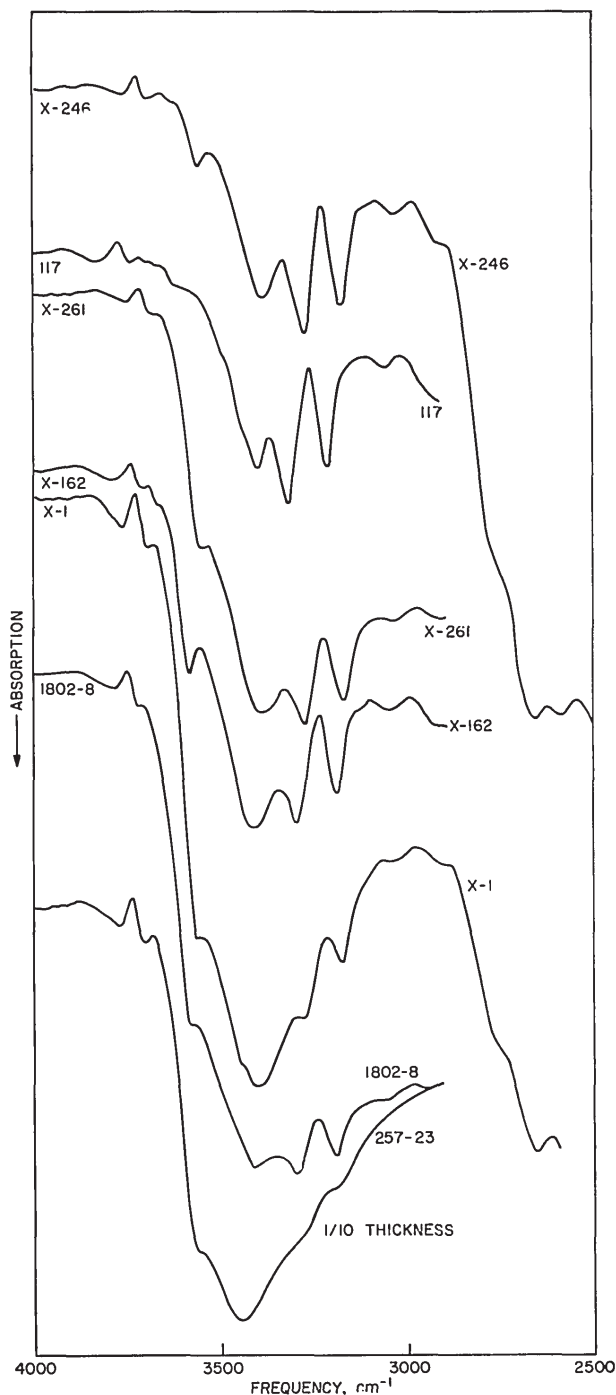

Fig. 3. Infrared absorption spectra of synthetic and natural quartz grown under various conditions. The individual curves were recorded in percent transmission on approximately equal thicknesses, but the ordinates have been displaced for clarity. Sample descriptions are in Table I.

pected by its exclusion. The results for H-2 where nutrient was made from SiCl_4 , however, indicate that this is not so, since essentially no Al^{3+} was present during growth. Chemical analyses for Fe and Al in the concentration ranges present in synthetic quartz have not yielded useful data on which to base correlations between the ion and a crystal property.⁷ But from the

previously established relationship between OH and acoustic Q , (Ref. 4) one would expect that procedures which reduce OH such as the reduction of the Fe^{3+} concentration in the system will result in Q improvements.

Conclusions

Crystalline quartz having a very high (comparable with or slightly better than natural quartz) uv and ir transmission can be produced by hydrothermal growth at rates up to 1.78 mm/day under conditions which reduce the inclusion of Fe and OH in the crystal. Crystallization in an inert (Ag or Ag plated) system in the presence of LiNO_2 yields such crystals. The distribution constant of Fe is dependent upon the OH present in the crystal so that LiNO_2 , which reduces OH greatly reduces Fe and improves both the ir and uv transmission. Inert conditions further reduce the Fe concentration in solution and hence in the crystal with further improvement in uv transmission.

We would like to thank J. R. Boie for experimental assistance, E. D. Kolb for advice concerning the design of the Ag lined tube, and D. B. Fraser for advice on crystal H-2.

References

1. A. Kats, Phillips Res. Rep. **17**, 133, 201 (1962).
2. J. C. King, D. L. Wood, and D. M. Dodd, Phys. Rev. Lett. **4**, 500 (1960).
3. W. A. Senior, Ph. D. Thesis, Kings College, Univ. of London (1962).
4. D. M. Dodd and D. B. Fraser, J. Phys. Chem. Solids **26**, 673 (1965).
5. J. C. King, A. A. Ballman, and R. A. Laudise, J. Phys. Chem. Solids **23**, 1019 (1962).
6. A. A. Ballman, R. A. Laudise, and D. W. Rudd, Appl. Phys. Lett. **8**, 53 (1966).
7. R. A. Laudise, A. A. Ballman, and J. C. King, J. Phys. Chem. Solids **26**, 1309 (1965).
8. A. A. Ballman, Am. Mineral. **46**, 439 (1961).
9. L. I. Tsinober and L. G. Chentsova, Kristallografiya **4**, 633 (1959).
10. L. I. Tsinober, L. G. Chentsova, and A. A. Shternberg, *Growth of Crystals*, A. V. Shubnikov and N. N. Sheftal, Eds. (Consultants Bureau, Inc., New York, 1959), Vol. 2, p. 45.
11. A. A. Ballman and D. W. Rudd, to be published.
12. E. D. Kolb, U. S. Pat. 3,271,114 (6 Sept. 1966).
13. R. A. Laudise and R. A. Sullivan, Chem. Eng. Prog. **55**, 55 (1959); see also R. A. Laudise and J. W. Nielsen, *Solid State Physics*, F. Seitz and D. Turnbull, Eds. (Academic Press Inc., New York, 1961), Vol. 12 for discussion of equipment, especially Morey closure.
14. D. W. Rudd and A. A. Ballman, Western Electric Eng. **1**, 3 (1965).
15. E. D. Kolb, A. S. Coriell, R. A. Laudise, and A. R. Hutson, Materials Res. Bull. **2**, 1099 (1967).
16. D. M. Dodd and D. B. Fraser, Am. Mineral. **52**, 149 (1967).
17. T. I. Barry and W. J. Moore, Science **144**, 3616 (1964).
18. T. I. Barry, P. McNamara, and W. J. Moore, J. Chem. Phys. **42**, 2599 (1965).
19. G. Lehmann and W. J. Moore, J. Chem. Phys. **44**, 1741 (1966).
20. V. Garino-Canina, Rev. Opt. **34**, 365 (1955).
21. N. H. Turner and H. A. Lee, J. Chem. Phys. **43**, 1428 (1965).