

# Understanding Modern Digital Modulation Techniques

[Electronic Design](#)

[Lou Frenzel](#)

Louis E. Frenzel

Mon, 2012-01-23 12:00

Fundamental to all wireless communications is modulation, the process of impressing the data to be transmitted on the radio carrier. Most wireless transmissions today are digital, and with the limited spectrum available, the type of modulation is more critical than it has ever been.

The main goal of modulation today is to squeeze as much data into the least amount of spectrum possible. That objective, known as spectral efficiency, measures how quickly data can be transmitted in an assigned bandwidth. The unit of measurement is bits per second per Hz (b/s/Hz). Multiple techniques have emerged to achieve and improve spectral efficiency.

## Table of Contents

1. [Amplitude Shift Keying \(ASK\) and Frequency Shift Keying \(FSK\)](#)
2. [Binary Phase Shift Keying \(BPSK\) and Quadrature Phase Shift Keying \(QPSK\)](#)
3. [Data Rate And Baud Rate](#)
4. [Multiple Phase Shift Keying \(M-PSK\)](#)
5. [Quadrature Amplitude Modulation \(QAM\)](#)
6. [Amplitude Phase Shift Keying \(APSK\)](#)
7. [Orthogonal Frequency Division Multiplexing](#)
8. [Determining Spectral Efficiency](#)
9. [Other Factors Affecting Spectral Efficiency](#)
10. [Implementing Modulation And Demodulation](#)
11. [The Pursuit Of Greater Spectral Efficiency](#)
12. [Acknowledgment](#)
13. [References](#)

## Amplitude Shift Keying (ASK) and Frequency Shift Keying (FSK)

There are three basic ways to modulate a sine wave radio carrier: modifying the amplitude, frequency, or phase. More sophisticated methods combine two or more of these variations to improve spectral efficiency. These basic modulation forms are still used today with digital signals.

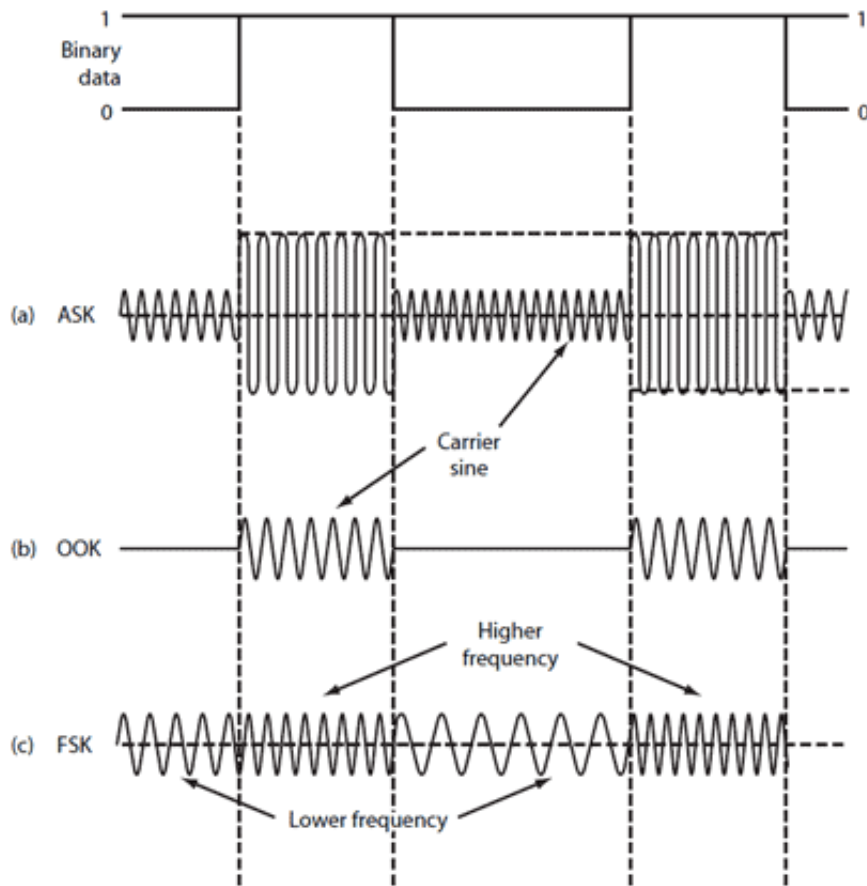

1. Three basic digital modulation formats are still very popular with low-data-rate short-range wireless applications: amplitude shift keying (a), on-off keying (b), and frequency shift keying (c). These waveforms are coherent as the binary state change occurs at carrier zero crossing points.

[Figure 1](#) shows a basic serial digital signal of binary zeros and ones to be transmitted and the corresponding AM and FM signals resulting from modulation. There are two types of AM signals: on-off keying (OOK) and amplitude shift keying (ASK). In [Figure 1a](#), the carrier amplitude is shifted between two amplitude levels to produce ASK. In [Figure 1b](#), the binary signal turns the carrier off and on to create OOK.

Related

[Modern DSP Chips Serve Up Variations On A Theme](#)

[Cooling Techniques Attack MPU Processing Heat](#)

[Today's Antennas Tune Into The Needs Of Modern Wireless Devices](#)

[Multi-Antenna Techniques Require Thorough Testing Solutions](#)

AM produces sidebands above and below the carrier equal to the highest frequency content of the modulating signal. The bandwidth required is two times the highest frequency content including any harmonics for binary pulse modulating signals.

Frequency shift keying (FSK) shifts the carrier between two different frequencies called the mark and space frequencies, or  $f_m$  and  $f_s$  ([Fig. 1c](#)). FM produces multiple sideband frequencies above and below the carrier

and the modulation index, which is:

$$m = \Delta f(T)$$

$\Delta f$  is the frequency deviation or shift between the mark and space frequencies, or:

$$\Delta f = f_s - f_m$$

T is the bit time interval of the data or the reciprocal of the data rate (1/bit/s).

Smaller values of m produce fewer sidebands. A popular version of FSK called minimum shift keying (MSK) specifies  $m = 0.5$ . Smaller values are also used such as  $m = 0.3$ .

Here are two ways to further improve the spectral efficiency for both ASK and FSK. First, select data rates, carrier frequencies, and shift frequencies so there are no discontinuities in the sine carrier when changing from one binary state to another. These discontinuities produce glitches that increase the harmonic content and the bandwidth.

The idea is to synchronize the stop and start times of the binary data with when the sine carrier is transitioning in amplitude or frequency at the zero crossing points. This is called continuous phase or coherent operation. Both coherent ASK/OOK and coherent FSK have fewer harmonics and a narrower bandwidth than non-coherent signals.

A second technique is to filter the binary data prior to modulation. This rounds the signal off, lengthening the rise and fall times and reducing the harmonic content. Special Gaussian and raised cosine low pass filters are used for this purpose. GSM cell phones widely use a popular combination, Gaussian filtered MSK (GMSK), which allows a data rate of 270 kbits/s in a 200-kHz channel.

### Binary Phase Shift Keying (BPSK) And Quadrature Phase Shift Keying (QPSK)

A very popular digital modulation scheme, binary phase shift keying (BPSK), shifts the carrier sine wave  $180^\circ$  for each change in binary state ([Fig. 2](#)). BPSK is coherent as the phase transitions occur at the zero crossing points. The proper demodulation of BPSK requires the signal to be compared to a sine carrier of the same phase. This involves carrier recovery and other complex circuitry.

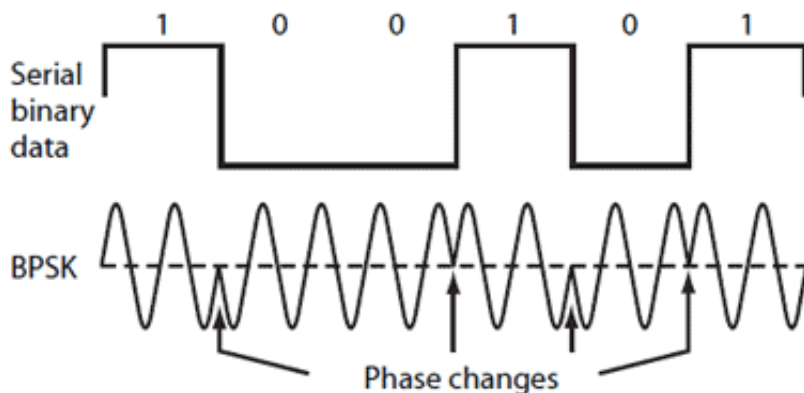

*2. In binary phase shift keying, note how a binary 0 is  $0^\circ$  while a binary 1 is  $180^\circ$ . The phase changes when the binary state switches so the signal is coherent.*

the previous bit signal. BPSK is very spectrally efficient in that you can transmit at a data rate equal to the bandwidth or 1 bit/Hz.

In a popular variation of BPSK, quadrature PSK (QPSK), the modulator produces two sine carriers 90° apart. The binary data modulates each phase, producing four unique sine signals shifted by 45° from one another. The two phases are added together to produce the final signal. Each unique pair of bits generates a carrier with a different phase ([Table 1](#)).

TABLE 1: CARRIER PHASE SHIFT FOR EACH PAIR OF BITS REPRESENTED	
Bit pairs	Phase (degrees)
0 0	45
0 1	135
1 1	225
1 0	315

[Figure 3a](#) illustrates QPSK with a phasor diagram where the phasor represents the carrier sine amplitude peak and its position indicates the phase. A constellation diagram in [Figure 3b](#) shows the same information. QPSK is very spectrally efficient since each carrier phase represents two bits of data. The spectral efficiency is 2 bits/Hz, meaning twice the data rate can be achieved in the same bandwidth as BPSK.

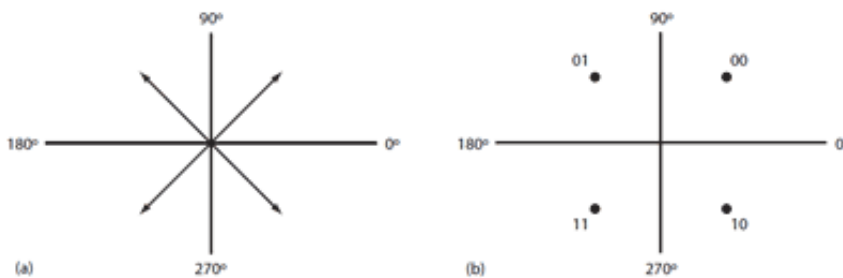

3. Modulation can be represented without time domain waveforms. For example, QPSK can be represented with a phasor diagram (a) or a constellation diagram (b), both of which indicate phase and amplitude magnitudes.

### Data Rate And Baud Rate

The maximum theoretical data rate or channel capacity (C) in bits/s is a function of the channel bandwidth (B) channel in Hz and the signal-to-noise ratio (SNR):

$$C = B \log_2 (1 + \text{SNR})$$

This is called the Shannon-Hartley law. The maximum data rate is directly proportional to the bandwidth

Another key factor is the baud rate, or the number of modulation symbols transmitted per second. The term symbol in modulation refers to one specific state of a sine carrier signal. It can be an amplitude, a frequency, a phase, or some combination of them. Basic binary transmission uses one bit per symbol.

In ASK, a binary 0 is one amplitude and a binary 1 is another amplitude. In FSK, a binary 0 is one carrier frequency and a binary 1 is another frequency. BPSK uses a  $0^\circ$  shift for a binary 0 and a  $180^\circ$  shift for a binary 1. In each of these cases there is one bit per symbol.

Data rate in bits/s is calculated as the reciprocal of the bit time ( $t_b$ ):

$$\text{bits/s} = 1/t_b$$

With one symbol per bit, the baud rate is the same as the bit rate. However, if you transmit more bits per symbol, the baud rate is slower than the bit rate by a factor equal to the number of bits per symbol. For example, if 2 bits per symbol are transmitted, the baud rate is the bit rate divided by 2. For instance, with QPSK a 70 Mb/s data stream is transmitted at a baud rate of 35 symbols/second.

### Multiple Phase Shift Keying (M-PSK)

QPSK produces two bits per symbol, making it very spectrally efficient. QPSK can be referred to as 4-PSK because there are four amplitude-phase combinations. By using smaller phase shifts, more bits can be transmitted per symbol. Some popular variations are 8-PSK and 16-PSK.

8-PSK uses eight symbols with constant carrier amplitude  $45^\circ$  shifts between them, enabling three bits to be transmitted for each symbol. 16-PSK uses  $22.5^\circ$  shifts of constant amplitude carrier signals. This arrangement results in a transmission of 4 bits per symbol.

While Multiple Phase Shift Keying (M-PSK) is much more spectrally efficient, the greater the number of smaller phase shifts, the more difficult the signal is to demodulate in the presence of noise. The benefit of M-PSK is that the constant carrier amplitude means that more efficient nonlinear power amplification can be used.

### Quadrature Amplitude Modulation (QAM)

The creation of symbols that are some combination of amplitude and phase can carry the concept of transmitting more bits per symbol further. This method is called quadrature amplitude modulation (QAM). For example, 8QAM uses four carrier phases plus two amplitude levels to transmit 3 bits per symbol. Other popular variations are 16QAM, 64QAM, and 256QAM, which transmit 4, 6, and 8 bits per symbol respectively ([Fig. 4](#)).

# Explore Litigation Insights

Docket Alarm provides insights to develop a more informed litigation strategy and the peace of mind of knowing you're on top of things.

## Real-Time Litigation Alerts



Keep your litigation team up-to-date with **real-time alerts** and advanced team management tools built for the enterprise, all while greatly reducing PACER spend.

Our comprehensive service means we can handle Federal, State, and Administrative courts across the country.

## Advanced Docket Research



With over 230 million records, Docket Alarm's cloud-native docket research platform finds what other services can't. Coverage includes Federal, State, plus PTAB, TTAB, ITC and NLRB decisions, all in one place.

Identify arguments that have been successful in the past with full text, pinpoint searching. Link to case law cited within any court document via Fastcase.

## Analytics At Your Fingertips



Learn what happened the last time a particular judge, opposing counsel or company faced cases similar to yours.

Advanced out-of-the-box PTAB and TTAB analytics are always at your fingertips.

## API

Docket Alarm offers a powerful API (application programming interface) to developers that want to integrate case filings into their apps.

## LAW FIRMS

Build custom dashboards for your attorneys and clients with live data direct from the court.

Automate many repetitive legal tasks like conflict checks, document management, and marketing.

## FINANCIAL INSTITUTIONS

Litigation and bankruptcy checks for companies and debtors.

## E-DISCOVERY AND LEGAL VENDORS

Sync your system to PACER to automate legal marketing.