

**IN THE UNITED STATES DISTRICT COURT
FOR THE EASTERN DISTRICT OF TEXAS
MARSHALL DIVISION**

MOBILE TELECOMMUNICATIONS
TECHNOLOGIES, LLC

v.

CLEARWIRE CORP., et al.

§
§
§
§
§
§

Case No. 2:12-cv-308-JRG-RSP

**CLAIM CONSTRUCTION
MEMORANDUM AND ORDER**

On June 7, 2013, the Court held a claim construction hearing concerning U.S. Patent No. 5,590,403 (the “403 Patent”). Having considered the arguments and evidence presented by the parties at the hearing and in their briefing (Dkt. Nos. 60, 61, and 64), the Court issues this Claim Construction Order.

The ‘403 Patent generally relates to a system for providing two-way communication between a plurality of transmitters and mobile units. ‘403 Patent at Abstract. The patent addresses techniques in which improved communication is provided over a relatively large area. ‘403 Patent at 1:8-14. The patent includes two independent claims. Claim 1 is directed toward concepts in which the transmitters are divided into a first and second set of transmitters. During a first time period a first block of information is transmitted by the first and second sets of transmitters in simulcast. During a second time period the first set of transmitters transmits a second block of information and the second set of transmitters transmits a third block of information. Independent claim 10 relates to a concept in which a region of space is divided into a plurality of zones, each zone having at least one base transmitter. A first set of transmitters assigned to a first zone transmits a first information signal in simulcast and a second set of transmitters assigned to a second zone transmits a second information signal in simulcast.

At least one transmitter assigned to the first set of transmitters may be dynamically reassigned from the first zone to the second zone.

APPLICABLE LAW

“It is a ‘bedrock principle’ of patent law that ‘the claims of a patent define the invention to which the patentee is entitled the right to exclude.’” *Phillips v. AWH Corp.*, 415 F.3d 1303, 1312 (Fed. Cir. 2005) (en banc) (quoting *Innova/Pure Water Inc. v. Safari Water Filtration Sys., Inc.*, 381 F.3d 1111, 1115 (Fed. Cir. 2004)). To determine the meaning of the claims, courts start by considering the intrinsic evidence. *See id.* at 1313. *C.R. Bard, Inc. v. U.S. Surgical Corp.*, 388 F.3d 858, 861 (Fed. Cir. 2004); *Bell Atl. Network Servs., Inc. v. Covad Commc’ns Group, Inc.*, 262 F.3d 1258, 1267 (Fed. Cir. 2001). The intrinsic evidence includes the claims themselves, the specification, and the prosecution history. *See Phillips*, 415 F.3d at 1314; *C.R. Bard, Inc.*, 388 F.3d at 861. Courts give claim terms their ordinary and accustomed meaning as understood by one of ordinary skill in the art at the time of the invention in the context of the entire patent. *Phillips*, 415 F.3d at 1312–13; *Alloc, Inc. v. Int’l Trade Comm’n*, 342 F.3d 1361, 1368 (Fed. Cir. 2003).

The claims themselves provide substantial guidance in determining the meaning of particular claim terms. *Phillips*, 415 F.3d at 1314. First, a term’s context in the asserted claim can be very instructive. *Id.* Other asserted or unasserted claims can also aid in determining the claim’s meaning because claim terms are typically used consistently throughout the patent. *Id.* Differences among the claim terms can also assist in understanding a term’s meaning. *Id.* For example, when a dependent claim adds a limitation to an independent claim, it is presumed that the independent claim does not include the limitation. *Id.* at 1314–15.

“[C]laims ‘must be read in view of the specification, of which they are a part.’” *Id.* (quoting *Markman v. Westview Instruments, Inc.*, 52 F.3d 967, 979 (Fed. Cir. 1995) (en banc)).

“[T]he specification ‘is always highly relevant to the claim construction analysis. Usually, it is dispositive; it is the single best guide to the meaning of a disputed term.’” *Id.* (quoting *Vitronics Corp. v. Conceptronic, Inc.*, 90 F.3d 1576, 1582 (Fed. Cir. 1996)); *Teleflex, Inc. v. Ficosa N. Am. Corp.*, 299 F.3d 1313, 1325 (Fed. Cir. 2002). This is true because a patentee may define his own terms, give a claim term a different meaning than the term would otherwise possess, or disclaim or disavow the claim scope. *Phillips*, 415 F.3d at 1316. In these situations, the inventor’s lexicography governs. *Id.* The specification may also resolve ambiguous claim terms “where the ordinary and accustomed meaning of the words used in the claims lack sufficient clarity to permit the scope of the claim to be ascertained from the words alone.” *Teleflex, Inc.*, 299 F.3d at 1325. But, “[a]lthough the specification may aid the court in interpreting the meaning of disputed claim language, particular embodiments and examples appearing in the specification will not generally be read into the claims.” *Comark Commc’ns, Inc. v. Harris Corp.*, 156 F.3d 1182, 1187 (Fed. Cir. 1998) (quoting *Constant v. Advanced Micro-Devices, Inc.*, 848 F.2d 1560, 1571 (Fed. Cir. 1988)); *see also Phillips*, 415 F.3d at 1323. The prosecution history is another tool to supply the proper context for claim construction because a patent applicant may also define a term in prosecuting the patent. *Home Diagnostics, Inc., v. Lifescan, Inc.*, 381 F.3d 1352, 1356 (Fed. Cir. 2004) (“As in the case of the specification, a patent applicant may define a term in prosecuting a patent.”).

Although extrinsic evidence can be useful, it is “‘less significant than the intrinsic record in determining the legally operative meaning of claim language.’” *Phillips*, 415 F.3d at 1317 (quoting *C.R. Bard, Inc.*, 388 F.3d at 862). Technical dictionaries and treatises may help a court understand the underlying technology and the manner in which one skilled in the art might use claim terms, but technical dictionaries and treatises may provide definitions that are too broad or

may not be indicative of how the term is used in the patent. *Id.* at 1318. Similarly, expert testimony may aid a court in understanding the underlying technology and determining the particular meaning of a term in the pertinent field, but an expert’s conclusory, unsupported assertions as to a term’s definition is entirely unhelpful to a court. *Id.* Generally, extrinsic evidence is “less reliable than the patent and its prosecution history in determining how to read claim terms.” *Id.*

CONSTRUCTION OF DISPUTED TERMS

A. “transmitter” / “base transmitter”

MTEL Proposed Construction	Clearwire Proposed Construction
No construction necessary	communications device having a data input, a control logic, modulators, a combiner, power amplifier(s), and antenna(e)

The parties first dispute the meaning of the terms “transmitter” and “base transmitter.” The Court finds that the terms “transmitter” and “base transmitter” should be given their plain and ordinary meaning.

Clearwire argues that the terms “transmitter” and “base transmitter” should be limited to the structure disclosed in Figures 13 and 14:

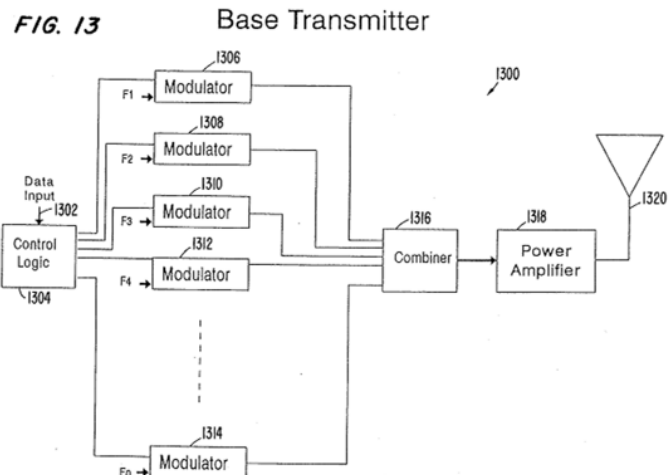

The Court rejects this position. The specification clearly identifies Figure 13, for example, as “show[ing] a first preferred embodiment of a base transmitter 1300.” ‘403 Patent at 15:44-46. Similarly, the specification describes Figure 14 as “show[ing] a second preferred embodiment of a base transmitter 1400.” *Id.* at 16:7-8. “Although the specification may aid the court in interpreting the meaning of disputed claim language, particular embodiments and examples appearing in the specification will not generally be read into the claims.” *Comark Commc’ns*, 156 F.3d at 1187. Although a person of ordinary skill in the art might understand the structure shown in Figures 13 and 14 to be a transmitter, it would be inappropriate to limit the term “transmitter” to **only** that structure, especially in light of the qualifying language of the specification. Thus, the Court declines to import the precise structure shown in Figures 13 and 14 into the claims.

MTEL argues that no construction is necessary for the terms “transmitter” and “base transmitter,” but at the hearing, declined to provide an explanation as to how these terms would be understood by a person of ordinary skill in the art. MTEL did imply, however, that a single unit transmitting multiple signals might be considered multiple transmitters. MTEL further argued that because both independent claims at issue are method claims, the infringement lies in a device’s ability to “transmit” rather than its specific structure. Although the Court recognizes that claims 1 and 10 are method claims, a person of ordinary skill in the art would understand the terms “transmitter” and “base transmitter” to refer to a structural unit, and thus, the number of transmitters in a given system or method is dependent on structure, not function. The specification supports such an interpretation: “[e]ach base transmitter unit . . . receives transmitter control data and message data transmitted from satellite 606.” ‘403 Pat. at 15:42-44.

Explore Litigation Insights

Docket Alarm provides insights to develop a more informed litigation strategy and the peace of mind of knowing you're on top of things.

Real-Time Litigation Alerts



Keep your litigation team up-to-date with **real-time alerts** and advanced team management tools built for the enterprise, all while greatly reducing PACER spend.

Our comprehensive service means we can handle Federal, State, and Administrative courts across the country.

Advanced Docket Research



With over 230 million records, Docket Alarm's cloud-native docket research platform finds what other services can't. Coverage includes Federal, State, plus PTAB, TTAB, ITC and NLRB decisions, all in one place.

Identify arguments that have been successful in the past with full text, pinpoint searching. Link to case law cited within any court document via Fastcase.

Analytics At Your Fingertips



Learn what happened the last time a particular judge, opposing counsel or company faced cases similar to yours.

Advanced out-of-the-box PTAB and TTAB analytics are always at your fingertips.

API

Docket Alarm offers a powerful API (application programming interface) to developers that want to integrate case filings into their apps.

LAW FIRMS

Build custom dashboards for your attorneys and clients with live data direct from the court.

Automate many repetitive legal tasks like conflict checks, document management, and marketing.

FINANCIAL INSTITUTIONS

Litigation and bankruptcy checks for companies and debtors.

E-DISCOVERY AND LEGAL VENDORS

Sync your system to PACER to automate legal marketing.